

Notes: Unless Otherwise Stated

Scheme Spec:

FLASH:NAND or NOR, 3.3V
DRAM: DDR, 16M*16 & 32M*16, 2.5V
Key: 6, L, R, Vol+, Vol-, OK, MENU
Power:DCIN, 5V, 2A; BAT, 4.2V, 1000mA
USB: OTG
Card: SD/MMC
TVout:CVBS
Headphone, MIC, FM, IR, RTC

Power Supply:

DC1: 3.3V, 1200mA, Periphery device
DC2: 1.2V, 1600mA, Core
DC3: 2.5V, 600mA, DDR
LD01: 3.3V, 30mA, RTC
LD02: 3V, 200mA, Analog

Schematics Index:

01 COVER
02 BLOCK
03 PIO ASSIGNMENT
04 MAIN CHIP
05 BESIDE MAIN CHIP
06 POWER & RTC
07 SDR & NAND & NOR
08 HP & TV & FM & MIC & CARD
09 USB & KEY & IR & G-SENSOR
10 LCD

Rev	Description	Date	Drawn	Checked	Approved
F1E200_STD_V1.0_M					
F1E200_STD_V1.1					

t e xet TB-550	
Title COVER	
Size A3	Document Number <Doc>
Date:	Sheet 2 of 11
	Rev

BLOCK

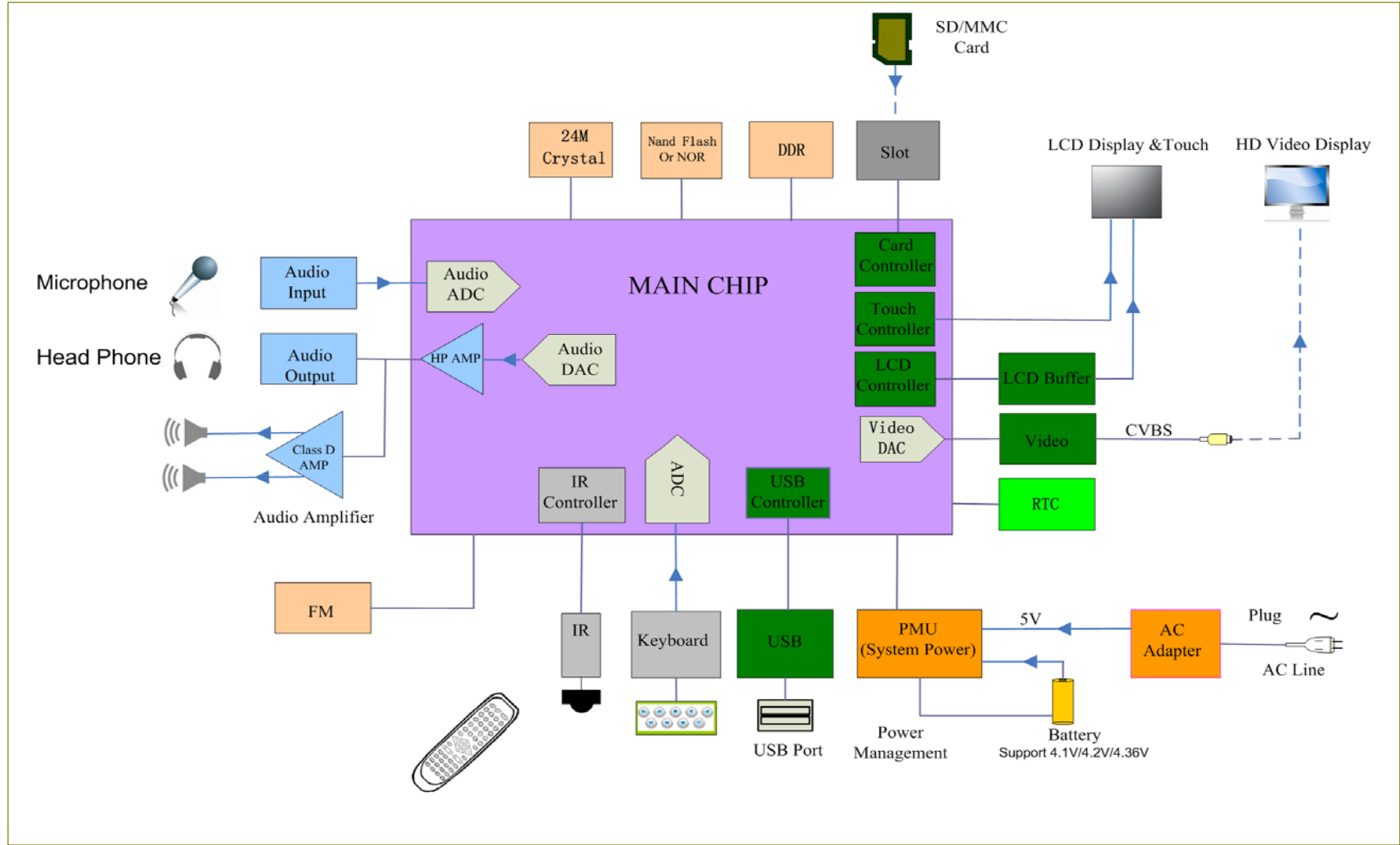

PIO ASSIGNMENT

Function	Pin Name	Default Function	Multi0	Multi1	Multi2	Multi3	Multi4	Notes
GPIOA(16)	PIOA0	SDC0_D1	SDC0_D1	JTAG_MS	SPI1_CS0	EINT0	PWM0	GSENSOR-INT
	PIOA1	SDC0_D0	SDC0_D0	JTAG_DI	SPI1_MOSI	EINT1		CARD
	PIOA2	SDC0_CLK	SDC0_CLK	UART0_TX	SPI1_CLK		CLKDBG0	
	PIOA3	SDC0_CMD	SDC0_CMD	JTAG_DO	SPI1_MISO			
	PIOA4	SDC0_D3	SDC0_D3	UART0_RX		EINT2	UART2_RX	USB : DetVBUS
	PIOA5	SDC0_D2	SDC0_D2	JTAG_CK	IR_RX	EINT3		IR_RX
	PIOA6	TWI0_SCK	TWI0_SCK	NCE2				IIC
	PIOA7	TWI0_SDA	TWI0_SDA	NCE3				
	PIOA8	PWM0	PWM0	SPI1_CS1		EINT4		LCD : PWM
	PIOA9			UART1_TX	IR TX	UART0_TX	EINT5	SPI1_CLK
PIOA10			UART1_RX	IR RX	UART0_RX	EINT6	SPI1_CS0	CARD:SD-CD#
AXP199	GPIO1	LCD-ACC-CN						
	GPIO2	PWM(option)						
	GPIO3	PA-SHDN#						
	GPIO7	DrvVBUS						USB

MAIN CHIP

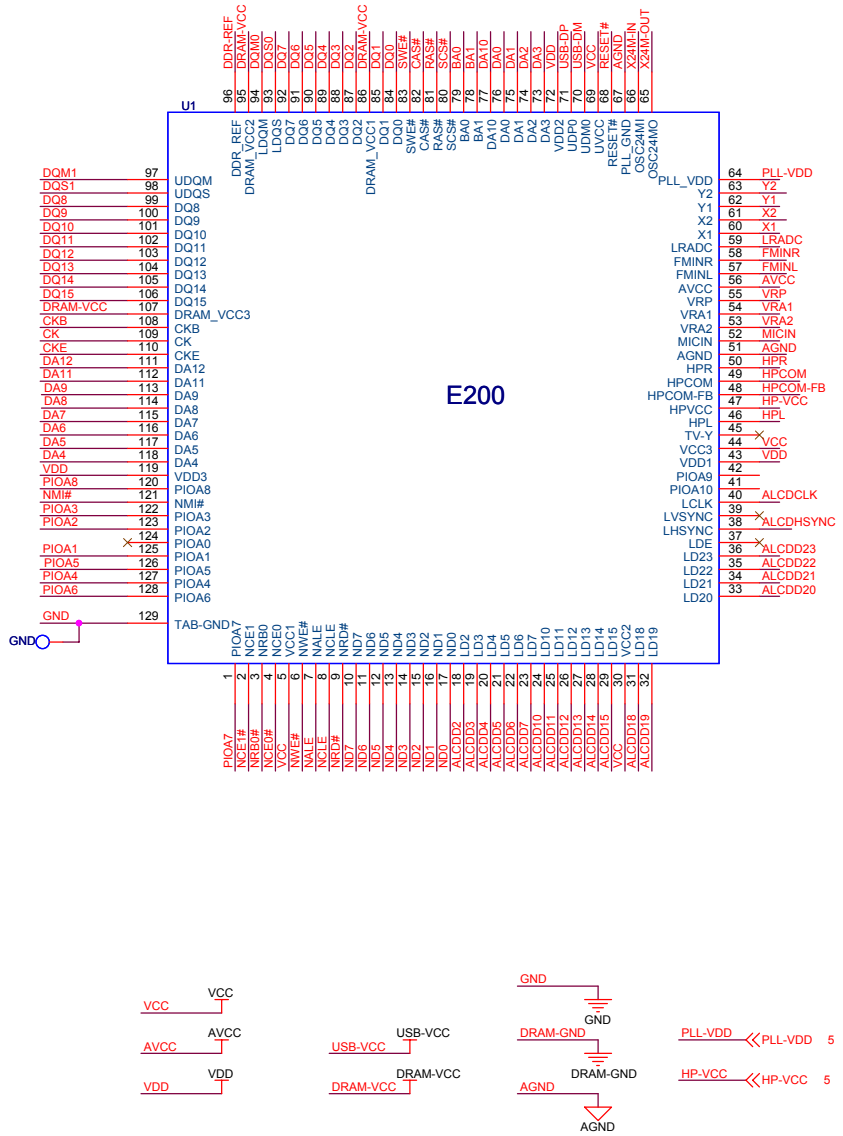

BESIDE MAIN CHIP

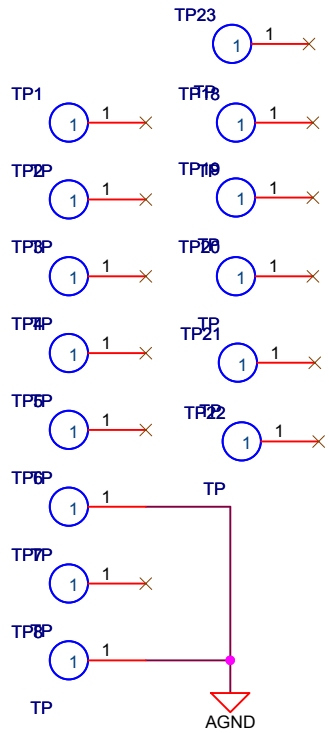
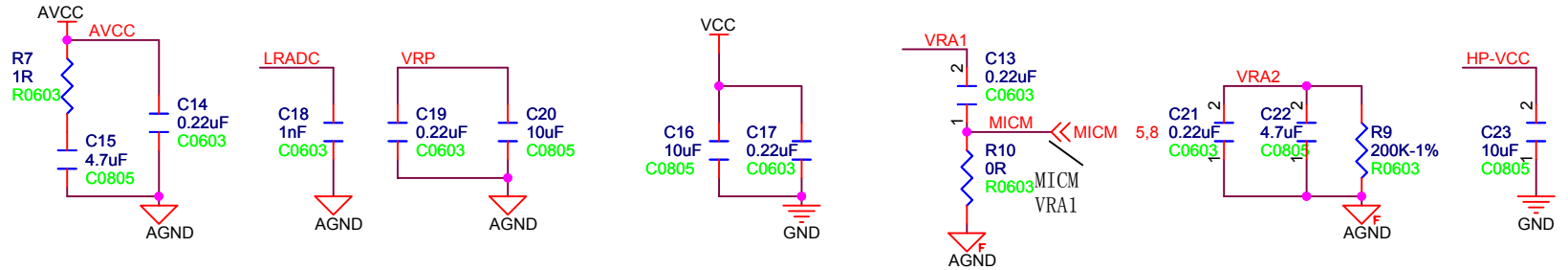
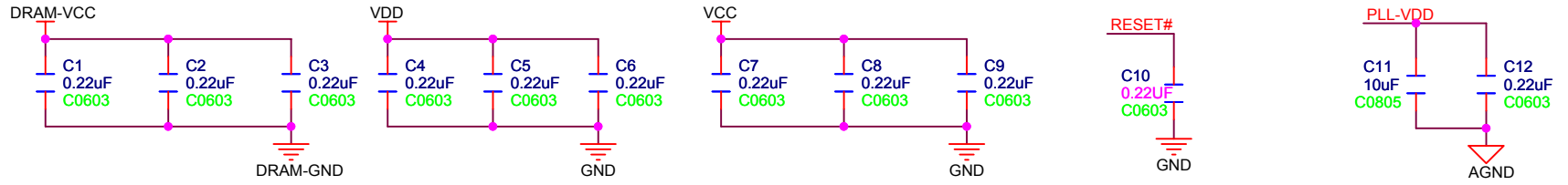
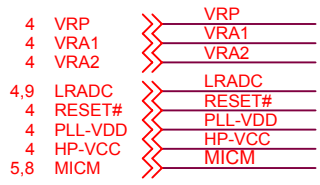

Crystal

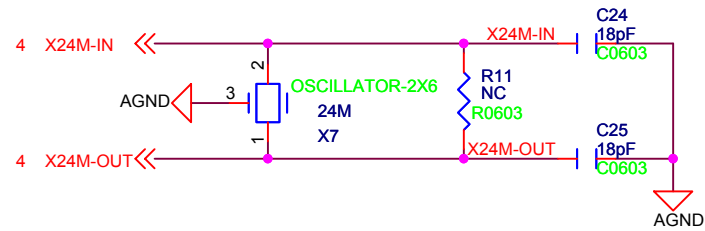

tExet TB-550	
Title BESIDE MAIN CHIP	
Size A4	Document Number <Doc>
Date:	Rev
2	6
Sheet 6 of 11	

DDR

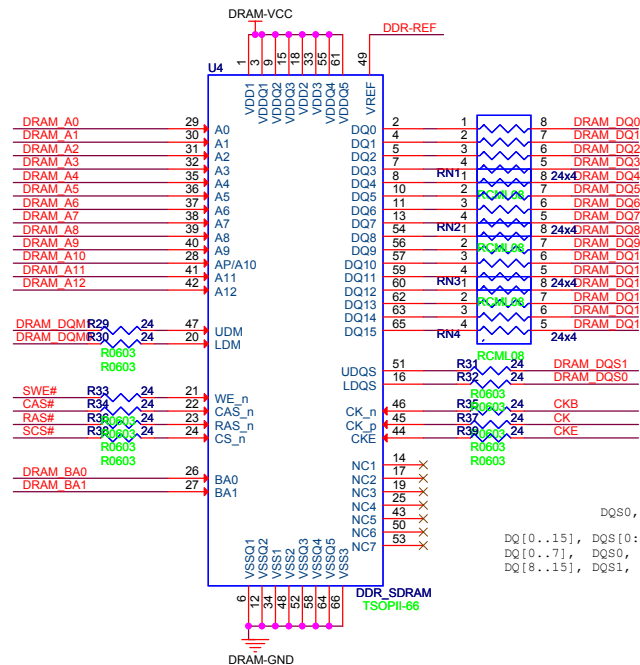
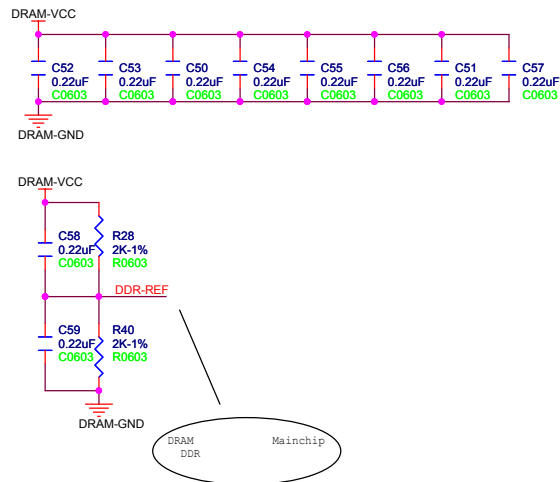
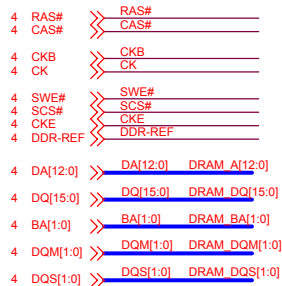

FM Module

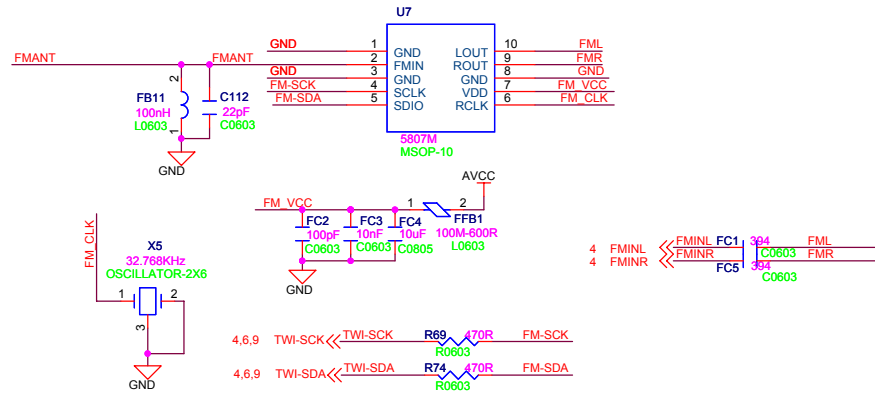

Head Phone & TVOUT

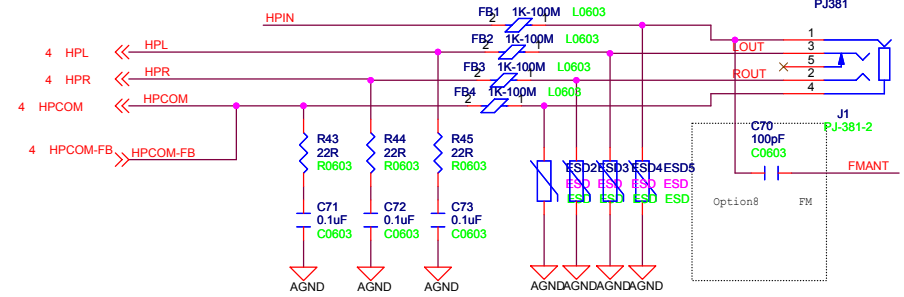

TF CARD

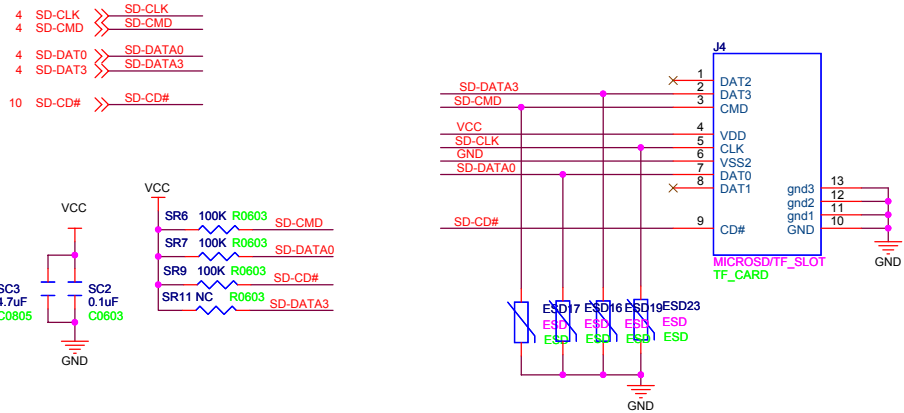

Speaker

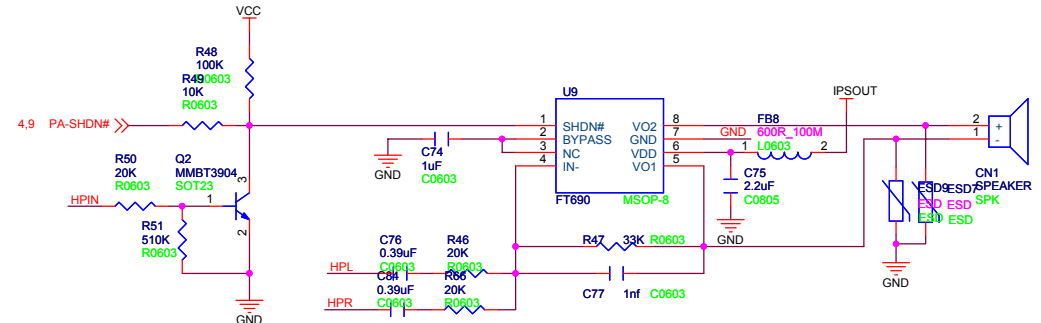

Microphone

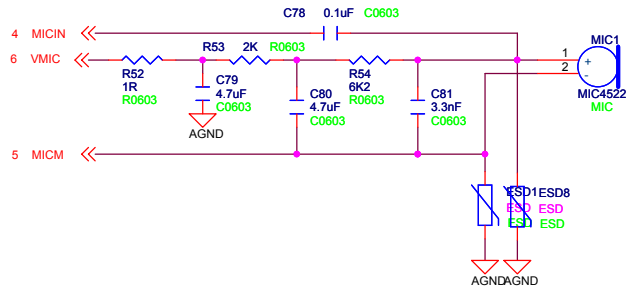

TB-550	
Title HP & FM & MIC & CARD & TV	
Size A3	Document Number <Doc>
Date:	Sheet 8 of 11

USB Port

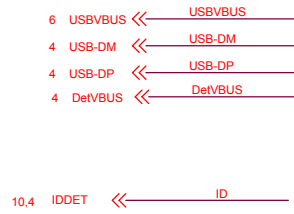

R3

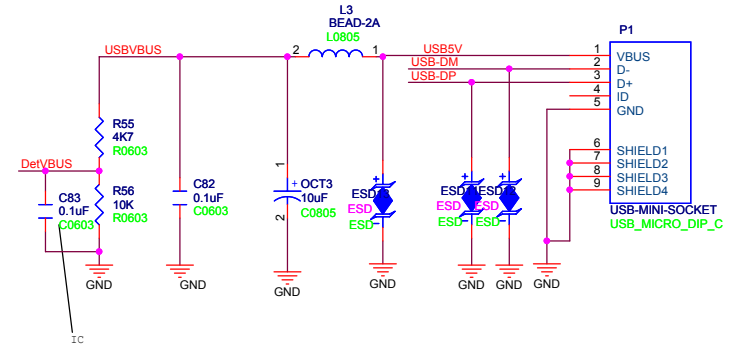

KEY

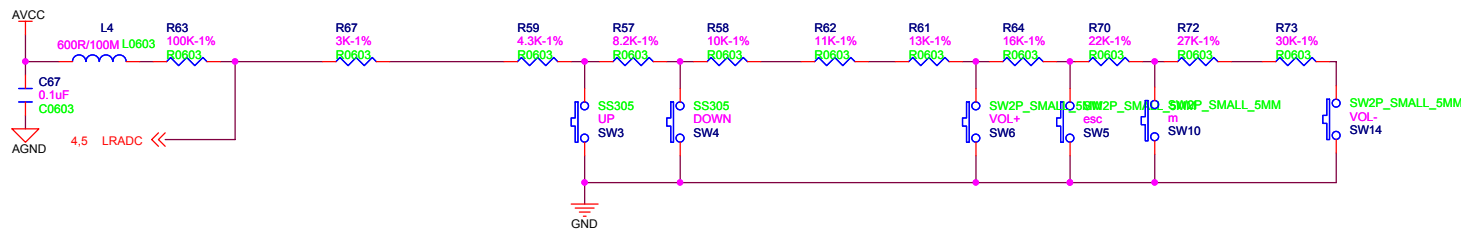

G-SENSOR

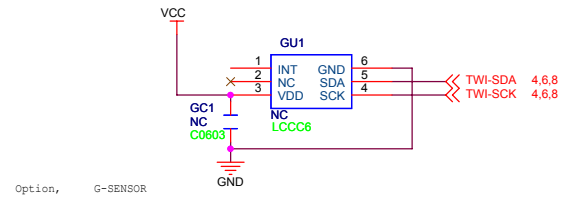

teXet TB-550	
Title USB & KEY & IR & G-SENSOR	
Size A3	Document Number <Doc>
Date:	Rev
Sheet 9 of 11	

4 ALCDD[23:18] >> ALCDD[23:18]
 4 ALCDD[15:10] >> ALCDD[15:10]
 4 ALCDD[7:2] >> ALCDD[7:2]
 4 ALCCLK >> ALCCLK

11 VNEG >> VNEG
 11 VPOS >> VPOS
 11 VCOM_PANEL >> VCOM_PANEL
 11 VDDH >> VDDH
 11 VEE >> VEE
 11 BORDER >> BORDER

ALCDD18 PWR2
 ALCDD19 PWRCOM

ALCDD20 SDOE
 ALCDD2 SDSHR
 ALCDD13 SDLE
 ALCCLK SDCLK

ALCDD21 SDCEL0

ALCDD14 GDRL
 ALCDD15 GDOE
 ALCDD22 GDCLK

ALCDD23 GDSP

ALCDD3 SDDO0
 ALCDD4 SDDO1
 ALCDD5 SDDO2
 ALCDD6 SDDO3
 ALCDD7 SDDO4
 ALCDD10 SDDO5
 ALCDD11 SDDO6
 ALCDD12 SDDO7

6,8,9 TWI-SCK << TWI-SCK
 6,8,9 TWI-SDA << TWI-SDA

6,8,9 PWR2 << PWR2
 6,8,9 PWRCOM << PWRCOM

6,8,9 Y1 << LPS

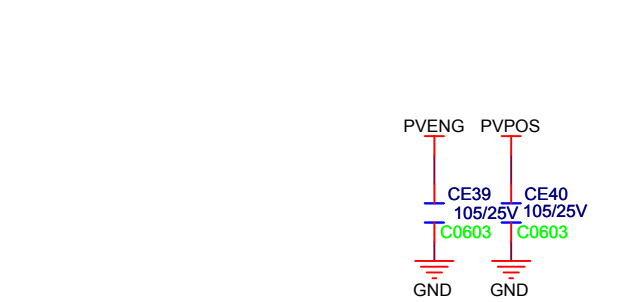
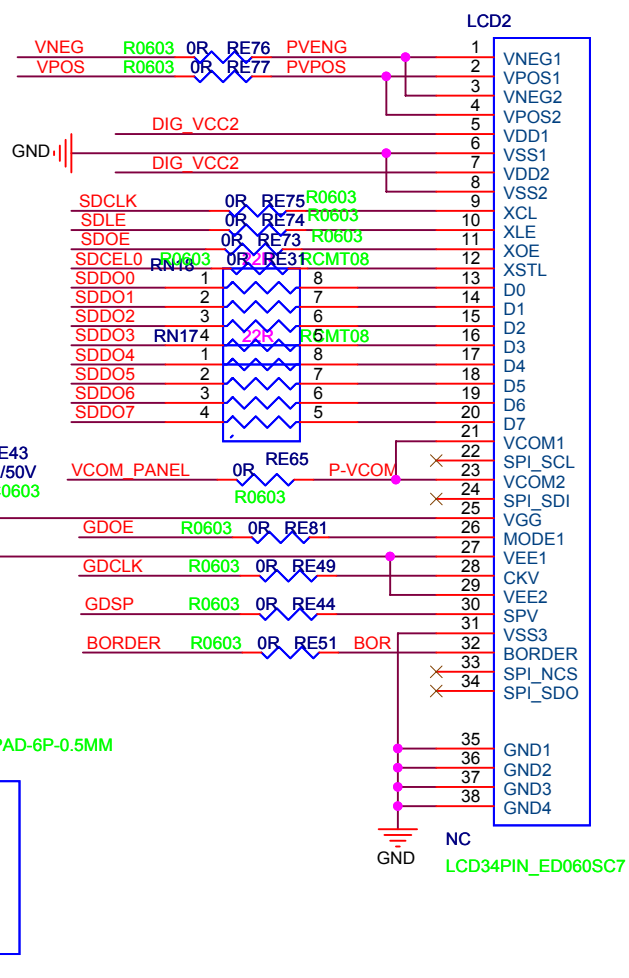
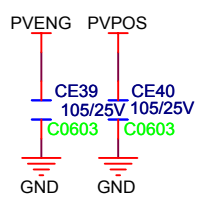
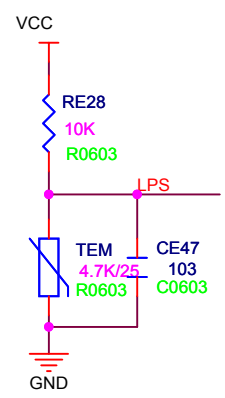
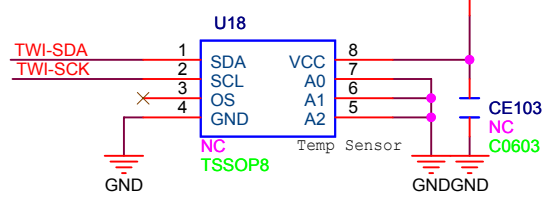
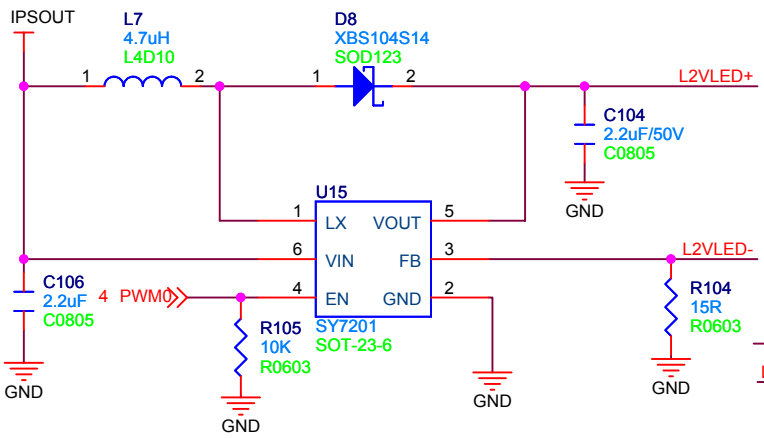
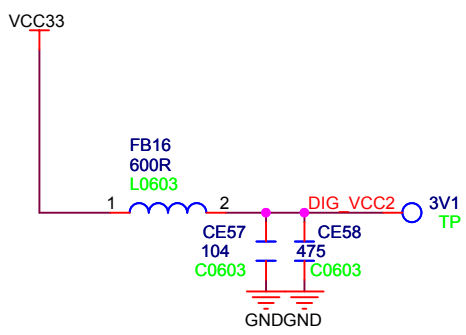

TEXET TB-550	
Title	LCD
Size	A4
Date:	Document Number <Doc>
Sheet	11 of 11

www.s-manuals.com