

POP[®]

POP NUT[™]

PNT800L-PC

Maintenance Manual



**Emhart[®]
Teknologies**
POP NUT[™]

Contents

Introduction	3
Safety Instructions	4
Specifications.....	5
Tool Parts	6
Packaged Accessories	6
PNT800L-PC Diagram.....	8
Parts List.....	10
Tool Setup.....	12
Mandrel and Nosepiece installation	13
Basic Tool Operation.....	14
Mandrel & Nosepiece Adjustment.....	14
Setting Force Valve Spring Selection.....	15
Tool Operation.....	16
Setting Force Adjustment.....	18
Adjustment for Standard POP NUTs™	18
Adjustment for ST & Thin Wall POP NUTs™	18
Adjustment of Setting Force.....	18
Maintenance	19
Clean & Lube Mandrel	19
Lubricate Rotating Parts.....	19
Recharging Hydraulics	20
Troubleshooting	22
Safety Data.....	24
EC Declaration of Conformity	26

Introduction

The PNT800L-PC is a small, lightweight tool for installing **POP®** brand POP NUT™ blind rivet nuts and other blind threaded inserts by adjusting the *setting force* to the insert being installed rather than stroke like traditional blind rivet nut tools. Controlling the setting force has the following benefits:

- No stroke adjustment is needed for the same nut in multiple application grips.
- Eliminated application & nut damage due to “double stroking”.
- Proper set achieved even with a small gap between the nut flange and Nosepiece.

Table 1 lists the POP NUT™ blind rivet nuts that can be fastened using this tool. The Nosepiece and Mandrel must be changed to fit some sizes of POP NUT™. (See Table 5, *Mandrel and Nosepiece Requirements* table in the *Specification* section)

Table 1: POP NUT™ blind rivet nut range

Thread Size	Material			
	Aluminum	Steel	Steel RLT	Stainless
M4X0.7 8-32			✓	✓
M5X0.8 10-24 10-32		✓	✓	✓
M6X1.0 ¼-20	✓	✓	✓	✓
M8X1.25 5/16-18	✓	✓	✓*	✓*
M10X1.5 3/8-16	✓	✓		

* Need to set tool at 0.55 MPa [80 psi] Minimum.



Safety Instructions



TO INSURE PROPER FUNCTIONING AND SAFE OPERATION READ THIS MANUAL CAREFULLY BEFORE SETTING UP OR OPERATING THE **POP NUT** SERIES TOOLS

DEFINITIONS:

- **CAUTION!** – Failure to observe this precaution could result in physical damage or minor injury.
- **WARNING!** – Failure to observe this precaution could result in physical damage, serious injury or even death.

CAUTION!

1. DO NOT use this tool in a manner other than that recommended by Emhart Teknologies.
2. DO NOT modify the tool in any way. Modification will void any applicable warranties and could result in damage to the tool or physical injury to the user.
3. Disconnect air supply when adjusting, servicing or removing any part of the tool.
4. Trained personnel must perform tool repair and/or maintenance at prescribed intervals.
5. Only use genuine Emhart Teknologies parts for tool maintenance and repair.
6. Do not operate the tool with the Nose Housing removed.
7. Keep fingers away from the front of the tool when connecting the air supply or using the tool.
8. Do not attempt to turn the Mandrel when the air supply is connected.
9. Keep hair, fingers and loose clothing away from moving parts of the tool.
10. Do not direct tool exhaust towards anyone. The tool uses lubricated air and may eject oil mist or debris.
11. Do not use organic solvents to clean the tool, this may damage the tool.
12. Wash hands thoroughly if exposed to hydraulic fluid or lubricant.

WARNING!

1. DO NOT exceed the maximum recommended air pressure of 0.6 MPa (87 psi / 6.0 bar).
2. DO NOT point the tool at anyone when in use.
3. Always wear safety rated eye protection when using or when near a tool in use.
4. Inspect the tool and connections for damage, worn or loose parts before connecting to the air supply. If damaged, stop use immediately and have the tool repaired or replaced.
5. This tool is not designed for use in explosive atmospheres.

Specifications

Table 2: Tool Specifications

Feature	Specification
Weight	1.81 kg (3.99 lbs)
Overall length	287 mm (11.3 in)
Overall height	268 mm (10.4 in)
Tool Stroke	1.3 – 8.5 mm (0.05 - 0.335 in)
Pulling Force	17 kN @ 5.0 bar (3824 lbf @ 72.5 psi)
Air Supply	0.5 - 0.6MPa (5 - 6 bar) (72.5 - 87 psi)
Hydraulic Oil	See Table 3, <i>Specified Hydraulic Oils</i>
Setting capacity	See Table 1, <i>POP NUT™ blind rivet nut range</i>
Tool Noise Level	$L_{Aeq,T} = 72.7$ dB(A), $L_{WA} = 77.6$ dB(A), $L_{Peak} = 106.3$ dB(C)
Tool Vibration Level	0.42 m/s ² , Time to 2.5 m/s ² > 24hrs (EAV)

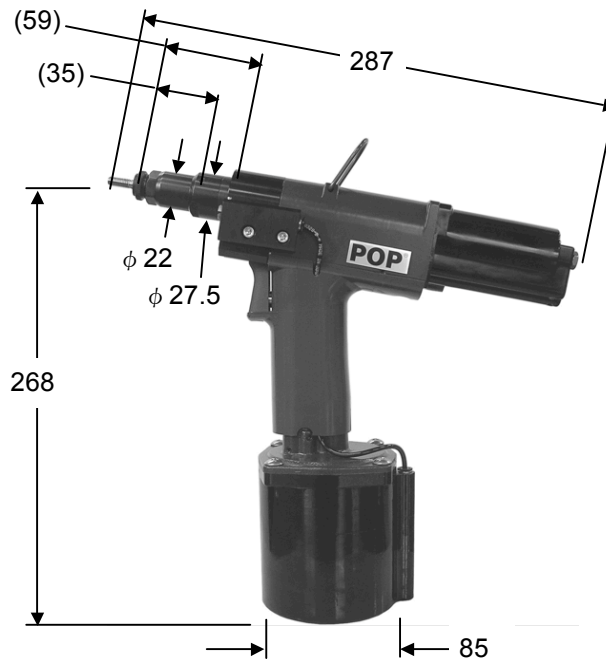

Figure 1: Tool Dimensions (mm)

Hydraulic oil

Use only Emhart Teknologies specified hydraulic lubrication oils as shown in Table 3. Use of any other oil could reduce the tool performance or even damage the tool.

Table 3: Specified Hydraulic Oils

Company name	Product name
Mobile	Mobile DTE26
Shell	Shell Telus Oil C68
Idemitsu	Daphne Hydro 68A
Cosmo	Cosmo Olpas 68
Esso	Telesso 68
Nisseki	FBK RO68
Mitsubishi	Diamond Lube RO68 (N)

Tool Parts

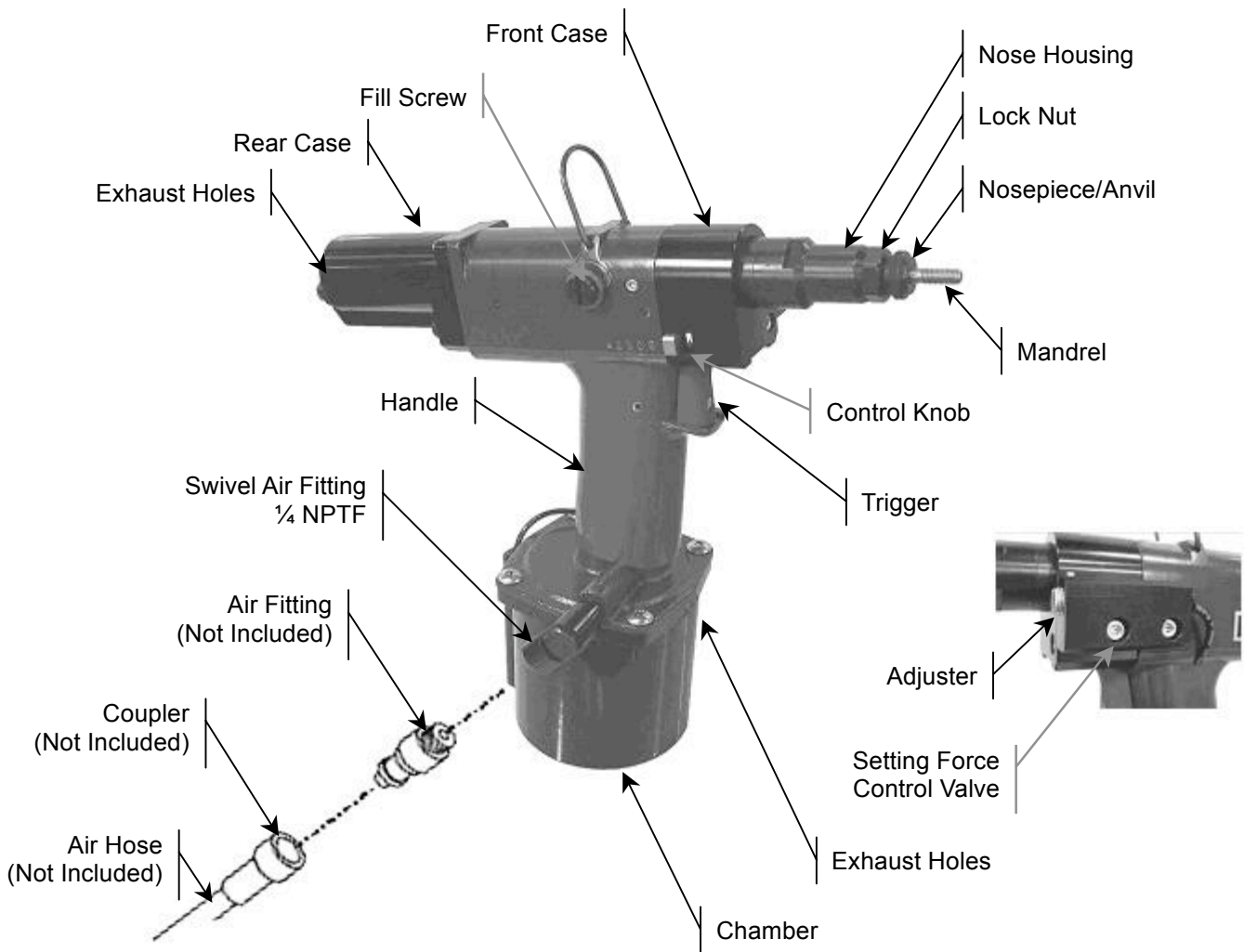

Figure 2: Tool Parts Diagram

Packaged Accessories

Table 4: Packaged Accessories

Part No.	Item	Qty
PNT800L-PC-T	PNT800L-PC POP NUT™ Tool	1
PNT600-132	Hook	1
PNT600-133	Hex wrench 1.5 mm	1
DPN907-006	Cap screw M4 X 20	1
DPN277-179	POP NUT™ Mandrel Release	1
DPN901-023	Valve Spring	1
FG2245	Operating Instructions	1
FG2267	Maintenance Manual	1
FG2222	Warranty Card	1

Table 5: Mandrel and Nosepiece requirements

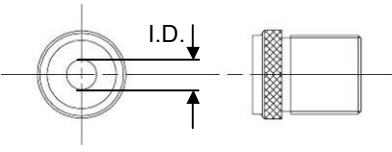
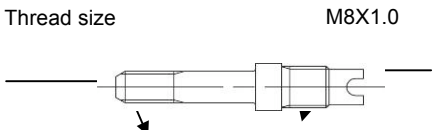
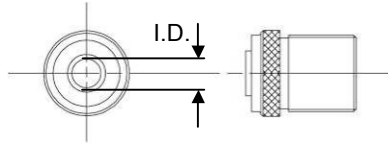
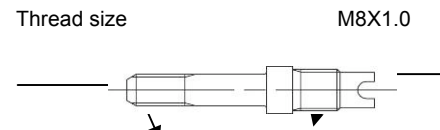
Thick Wall (Std & ST) POP NUT Thread size	Flat Nosepiece		Mandrel	
				
	Part No.	I.D.	Part No.	Thread size
M4X0.7	PNT600-02-4	φ4.5	PNT600-01-4	M4X0.7
M5X0.8	PNT600-02-5	φ5.1	PNT600-01-5	M5X0.8
M6X1.0	PNT600-02-6	φ6.1	PNT600-01-6	M6X1.0
M8X1.25	PNT600-02-8	φ8.1	PNT600-01-8	M8X1.25
M10X1.5	PNT600-02-10	φ10.1	PNT600-01-10	M10X1.5
8-32	PNT600-02-832	φ 4.3	PNT600-01-832	8-32
10-24	PNT600-02-5	φ5.1	PNT600-01-1024	10-24
10-32	PNT600-02-5	φ5.1	PNT600-01-1032	10-32
¼-20	PNT600-02-420	φ 6.5	PNT600-01-420	¼-20
5/16-18	PNT600-02-8	φ8.1	PNT600-01-518R	5/16-18
3/8-16	PNT600-02-10	φ10.1	PNT600-01-616R	3/8-16
Thin Wall (TK,TL,TH) POP NUT Thread size	Piloted Nosepiece		Mandrel	
				
	Part No.	I.D.	Part No.	Thread size
M4X0.7	PNT600-02-4P	φ4.3	PNT600-01-4P	M4X0.7
M5X0.8	PNT600-02-5P	φ5.1	PNT600-01-5P	M5X0.8
M6X1.0	PNT600-02-6P	φ6.1	PNT600-01-6P	M6X1.0
M8X1.25	PNT600-02-8P	φ8.1	PNT600-01-8P	M8X1.25
M10X1.5	PNT600-02-10P	φ10.1	PNT600-01-10P	M10X1.5
8-32	PNT600-02-4P	φ 4.3	PNT600-01-832	8-32
10-24	PNT600-02-5P	φ5.1	PNT600-01-1024	10-24
10-32	PNT600-02-5P	φ5.1	PNT600-01-1032	10-32
¼-20	PNT600-02-420P	φ 6.5	PNT600-01-420	¼-20
5/16-18	PNT600-02-8P	φ8.1	PNT600-01-518	5/16-18
3/8-16	PNT600-02-10P	φ10.1	PNT600-01-616	3/8-16

* Refer to the *Tool Setup* section for details of Nosepiece and Mandrel installation.

PNT800L-PC Diagram

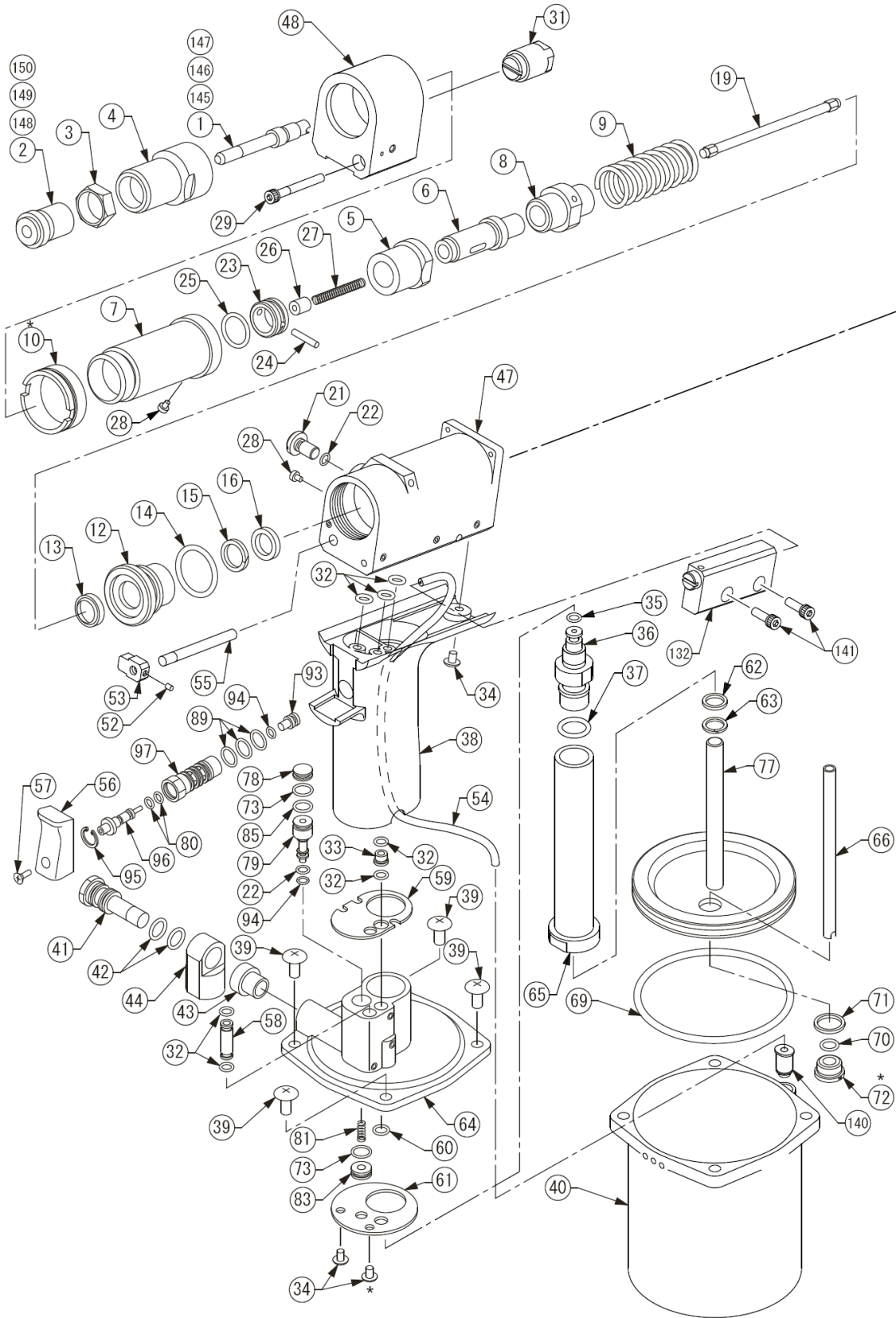

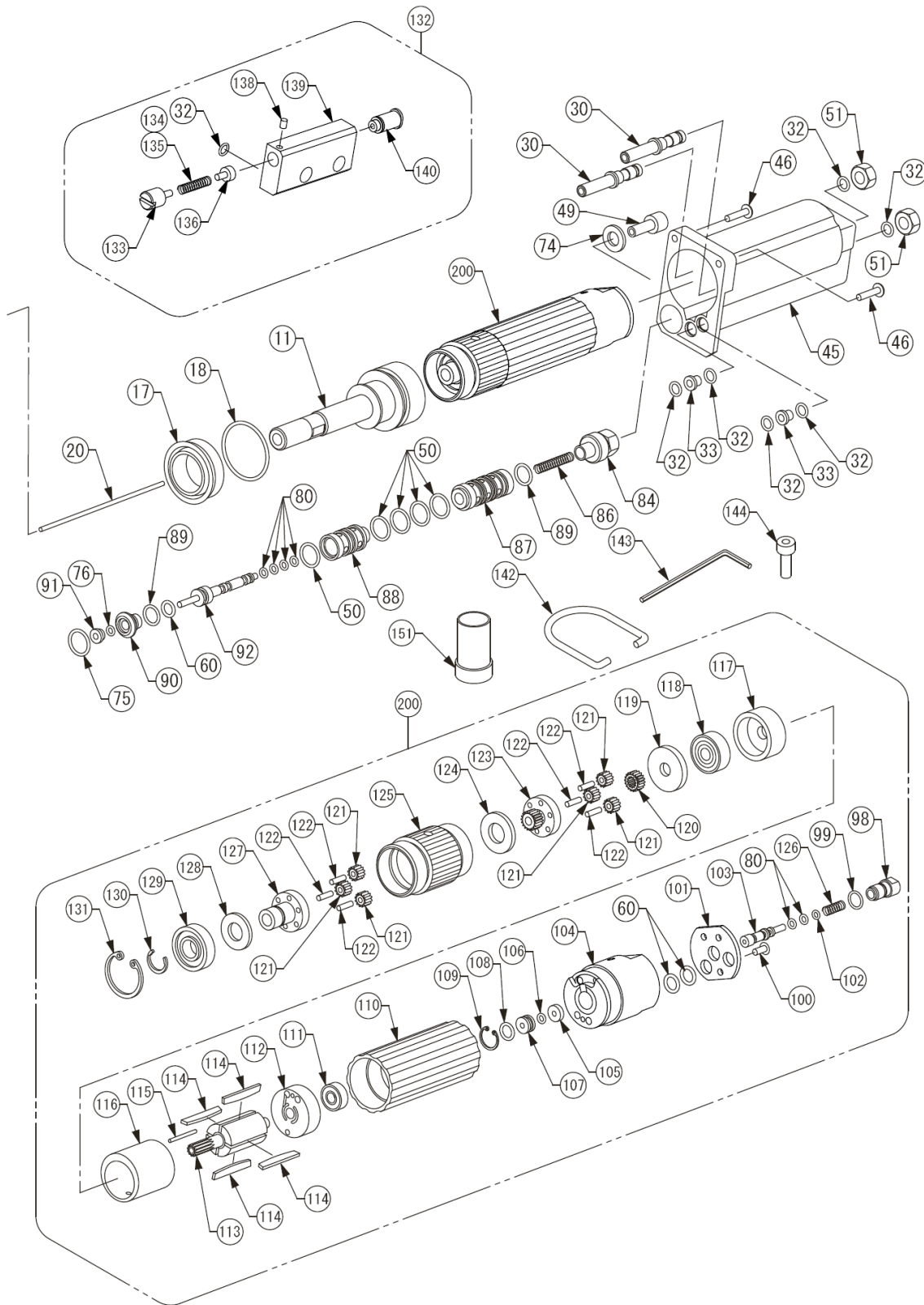

Parts List

Item	Part No.	Description	Qty
1	PNT600-01-6P	Mandrel M6	1*
2	PNT600-02-6	Nose Piece M6	1*
3	PNT600-03	Lock Nut	1
4	PNT600-04A	Nose Housing	1
5	DPN277-001	Spin Pull Head Case	1
6	DPN277-002	Spin Pull Head	1
7	PNT600-07B	Mast Housing	1
8	DPN277-003	Joint	1
9	DPN901-004	Return Spring	1
10	PNT600-10	Housing Lock	1
11	DPN277-004	Hydraulic Piston	1
12	DPN277-005	Rod Seal Case	1
13	DPN908-009	Scraper	1
14	DPN900-031	O-Ring	1
15	DPN908-010	Backup Ring	1
16	DPN908-011	Penta Seal	1
17	DPN908-012	Piston Seal	1
18	DPN900-032	O-Ring	1
19	PNT600-19A	Bit	1
20	PNT600-20	Start Bar	1
21	DPN239-047	Fill Screw	1
22	DPN900-033	O-Ring	2
23	DPN277-006	Lock Pin Holder	1
24	DPN277-007	Lock Pin	1
25	DPN900-034	O-Ring	1
26	PNT600-26	Lock Pin Pusher	1
27	DPN901-009	Spring	1
28	DPN907-005	Socket Head Cap Screw	2
29	DPN907-011	Socket Head Cap Screw	1
30	PNT600-30A	Rear Case Tube	2
31	DPN277-304	Cylinder	1
32	DPN900-015	O-Ring	13
33	PNT600-33A	Joint Adapter	3
34	PNT600-34	Truss Head Screw	3
35	DPN900-035	O-Ring	1
36	DPN277-008	Sleeve Upper	1
37	DPN900-036	O-Ring	1
38	DPN277-009	Handle	1

Item	Part No.	Description	Qty
39	PNT600-039	Truss Head Screw	4
40	DPN277-183	Chamber	1
41	PNT600-41A	R Joint Adapter	1
42	DPN900-021	O-Ring	2
43	PNT600-43	R Joint Spacer	1
44	PNT600-44B	R Joint	1
45	PNT600-45A	Rear Case	1
46	PNT600-46	Truss Head Screw	2
47	DPN277-010	Handle Upper	1
48	DPN277-301	Front Case	1
49	PNT600-49	T Valve End Screw	1
50	DPN900-037	O-Ring	5
51	PNT600-51	Hexagon Thin Nut	2
52	DPN905-004	Socket Set Screw	1
53	DPN277-302	Control Knob	1
54	DPN277-308	Air Tube	1
55	DPN277-303	T Valve Push Rod	1
56	DPN277-011	Trigger	1
57	DPN277-071	Flat Head Screw M3X8	1
58	PNT600-58	Joint Tube	1
59	PNT600-59A	Assist Plate	1
60	DPN900-006	O-Ring	2
61	PNT800-14	Retainer Plate	1
62	DPN908-024	Penta Seal	1
63	DPN908-025	Backup Ring	1
64	DPN277-012	Handle Lower	1
65	DPN277-300	Sleeve	1
66	PNT800-05	Tube	1
69	DPN900-038	O-Ring	1
70	DPN900-039	O-Ring	1
71	PNT600-71	Washer	1
72	PNT600-72	Tube Seal Case	1
73	DPN900-011	O-Ring	2
74	DPN909-001	SS-Washer	1
75	DPN900-040	O-Ring	1
76	DPN900-023	O-Ring	1
<u>77</u>	FAN277-299	Air Piston Assembly	1
78	PNT800-07A	J Valve Stopper	1

Item	Part No.	Description	Qty
79	PNT800-08A	J Valve Rod	1
80	DPN900-014	O-Ring	6
81	DPN901-010	Spring	1
83	DPN239-065	J Valve Cap	1
84	PNT800-10	T Valve Rear Case	1
85	DPN900-013	O-Ring	1
86	DPN901-011	Spring	1
87	PNT800-11	T Valve Center Case	1
88	PNT800-12	T Valve Front Case	1
89	DPN900-041	O-Ring	5
90	PNT600-90	T Valve Cap	1
91	PNT600-91	T Valve Front Piece	1
92	PNT600-92	T Valve Rod	1
93	PNT600-93	S Valve End	1
94	DPN900-012	O-Ring	2
95	DPN902-001	Retaining Ring	1
96	PNT600-96	S Valve Rod	1
97	PNT600-97B	S Valve Case	1
140	DPN277-309	Fitting	1
<u>132</u>	FAN277-311	Setting Force Control Valve	1set
133	DPN277-306	Adjuster	1
134	DPN901-023	Valve Spring	1
136	DPN277-305	Valve	1
32	DPN900-015	O-Ring	1
138	DPN905-006	Socket Set Screw	1
139	DPN277-307	Valve Case	1
140	DPN277-309	Fitting	1
141	DPN907-008	Socket Head Cap Screw	2
<u>200</u>	PNT600-200	Air Motor	1set
60	DPN900-006	O-Ring	2
80	DPN900-014	O-Ring	2
98	PNT600-98B	M Valve End	1
99	DPN900-042	O-Ring	1
100	DPN277-177	Flat Head Screw	1
101	PNT600-101A	Motor Case End Plate	1
102	DPN900-043	O-Ring	1
103	PNT600-103	M Valve Rod	1
104	PNT600-104	Motor Case End	1
105	PNT600-105	Washer	1
106	DPN900-044	O-Ring	1

Item	Part No.	Description	Qty
107	PNT600-107	O-Ring Holder	1
108	DPN900-045	O-Ring	1
109	DPN902-002	Retaining Ring	1
110	PNT600-110	Casing	1
111	PNT600-111	Ball Bearing	1
112	PNT600-112	Rear Plate	1
113	PNT600-113	Rotor	1
114	PNT600-114	Blade	4
115	PNT600-115	Spring Pin	1
116	PNT600-116	Cylinder	1
117	PNT600-117	Front Plate	1
118	PNT600-118	Ball Bearing	1
119	PNT600-119	Spacer	1
120	PNT600-120	Sun Gear	1
121	PNT600-121	Planet Gear	6
122	PNT600-122	Needle pin	6
123	PNT600-123	Gear Cage & Gear	1
124	PNT600-124	Spacer	1
125	PNT600-125	Internal Gear	1
126	DPN901-012	Spring	1
127	PNT600-127	Gear Cage	1
128	PNT600-128	Spacer	1
129	PNT600-129	Ball Bearing	1
130	DPN902-003	Retaining Ring	1
131	DPN902-004	Retaining Ring	1
Accessories			
135	DPN901-024	Valve Spring	1
142	PNT600-132	Hook	1
143	PNT600-133	HS Screw Key, 1.5mm	1
144	DPN907-006	Socket Head Cap Screw	1
145	PNT600-01-4	Mandrel, M4	1
146	PNT600-01-5P	Mandrel, M5	1
147	PNT600-01-8	Mandrel, M8	1
148	PNT600-02-4	Nose Piece, M4	1
149	PNT600-02-5	Nose Piece, M5	1
150	PNT600-02-8	Nose Piece, M8	1
151	DPN277-179	POP NUT Mandrel Release	1
*See table 5 for additional Mandrels and Nosepieces			

Tool Setup

Initial Setup

1. Check that the correct Nosepiece and Mandrel are fitted for the POP NUT™. See the *Basic Tool Operation* section for proper tool adjustment.
2. Connect an air fitting to the Swivel Air Fitting of the tool. The Swivel Air Fitting is a 1/4 NPTF thread.
3. Connect an Air Hose to the tool.
4. Connect an air filter, regulator and lubricator in the air line between the air supply and Air Hose connecting to the tool, within 3m [6 ft] of the tool.
5. Adjust the air pressure supply and oil drip volume of the lubricator
 - Air Pressure: 0.5-0.6 MPa. (72.5-87 psi)
 - Oil drip volume: 1-2 drops/ 20 nuts fastened

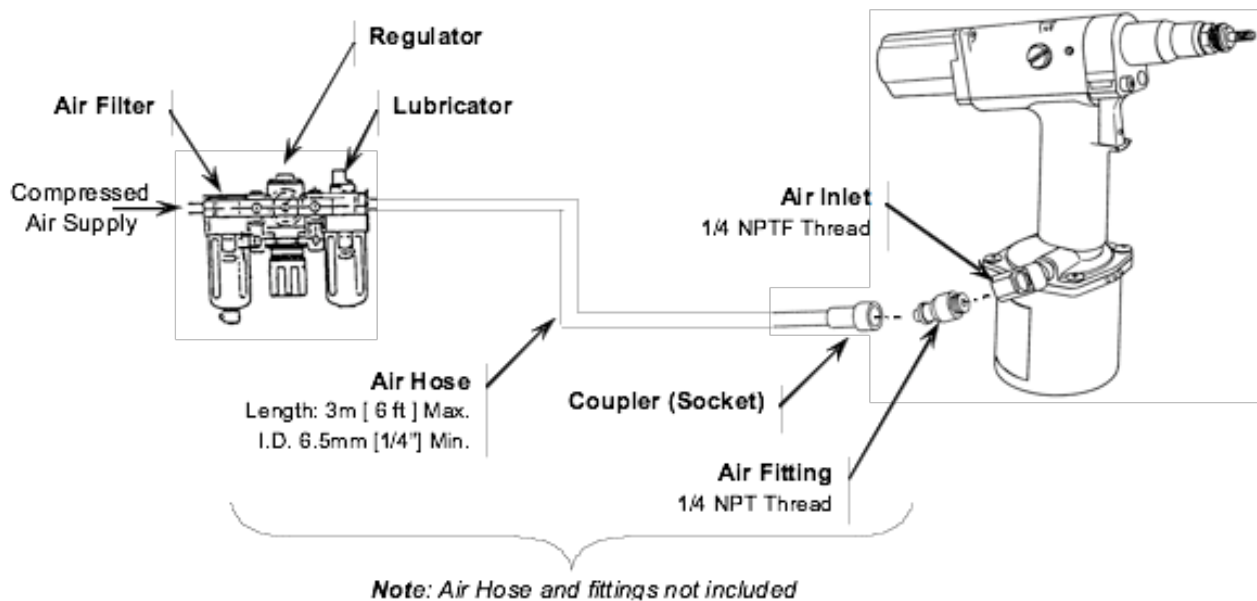

Figure 3: Tool Setup

Note: Refer to the instruction manual for the Lubricator used for the proper adjustment method and lubrication oils to use relating to air motors.



WARNING!

Use an air hose with a rating of 1.0 MPa (145 psi / 10 bar) or greater maximum ordinary operating pressure. Also make sure the hose material is suitable for the operating environment (i.e. oil proof, wear and abrasion resistance etc.). For details, refer to your hose manufacturer's catalog.

Mandrel and Nosepiece installation

Mandrel Installation

1. Disconnect the Air Supply
2. Select the correct Mandrel according to Table 5.
3. Remove the Nosepiece from the tool by loosening the Lock Nut and unscrewing it.
4. Insert the POP NUT™ Mandrel Release tool over the Mandrel and into the Nose Housing.
5. Push in to disengage the Lock Pin Holder from the Mandrel.
6. While holding the Mandrel Release in, unscrew the Mandrel by turning it counter-clockwise.
7. While holding the Mandrel Release in, screw in the desired Mandrel until it stops.
8. Release the Mandrel Release and rotate the Mandrel counter-clockwise to ensure the Lock Pin Holder has engaged the Mandrel.
9. Replace the Nosepiece.

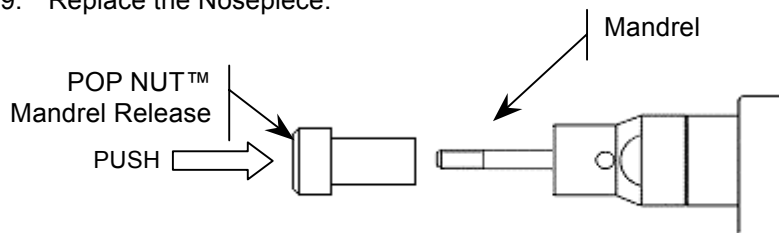

Figure 4: POP NUT™ Mandrel Release

Mandrel Installation (without POP NUT™ Mandrel Release, DPN277-185)

10. Disconnect the Air Supply
11. Select the correct Mandrel according to Table 5.
12. Remove the Nose Housing from the tool to expose the Mandrel and Spin Pull Head Case.
13. Pull the Lock Pin Holder back and unscrew the Mandrel by turning it counter-clockwise.
14. While holding the Lock Pin Holder back, screw in the desired mandrel until it stops.
15. Release the Lock Pin Holder.
Note: If the Lock Pin Holder does not return to its original position then turn the Mandrel counter-clockwise to ensure the Lock Pin engages the Mandrel and the holder moves forward.
16. Replace the Nose Housing.

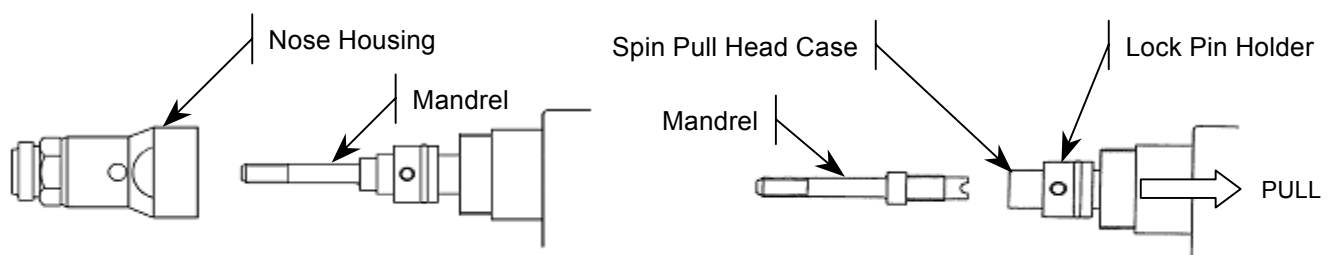

Figure 5: Mandrel Installation

Nosepiece Installation

1. Disconnect the Air Supply
2. Select the correct Nosepiece according to Table 5.
3. Remove the current Nosepiece from the tool by loosening the Lock Nut and unscrewing it.
4. Remove the Lock Nut from the Nosepiece
5. Thread the Lock Nut onto the desired Nosepiece
6. Screw the Nosepiece into the Nose Housing
7. Lock it in place by tightening the Lock Nut against the Nose Housing

Basic Tool Operation

Before setting POP NUTS™ with this tool, refer to the Safety Instructions and Tool Setup sections of this manual to ensure safe and reliable tool operation.

Mandrel & Nosepiece Adjustment

1. Verify that the correct Mandrel and Nosepiece are fitted to the tool for the desired POP NUT™ (See *Mandrel and Nosepiece Requirements* table in the Specifications section).

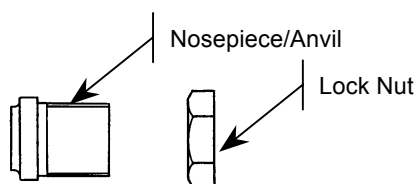

Figure 6: Nosepiece and Lock Nut

2. Loosen the lock nut on the tool and thread the Nosepiece all the way into the Nose Housing.
3. Thread the desired POP NUT™ onto the tool.

Open End POP NUTS™

- a. Thread the insert onto the mandrel until the Mandrel extends beyond the insert by approximately 1 full thread
- b. Unthread the Nosepiece until it is touching the flange of the insert
- c. Tighten the lock nut against the Nose Housing.

Closed End POP NUTS™

- a. Thread the insert onto the mandrel until it stops
- b. Unthread the insert on full turn (one thread pitch)
- c. Unthread the Nosepiece until it is touching the flange of the insert
- d. Tighten the lock nut against the Nose Housing.

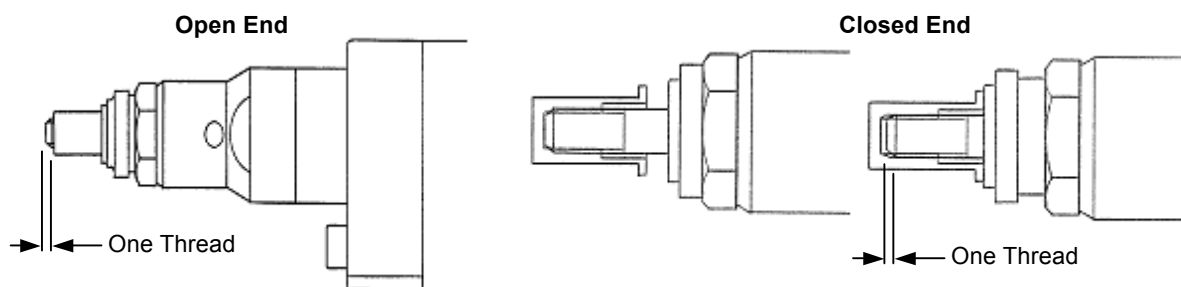

Figure 7: Proper Mandrel and Nosepiece adjustment

Setting Force Valve Spring Selection

- There are two types of spring used with the PNT800L-PC tool depending on the insert being used.
- Review the table below and select the proper Valve Spring for the insert being used.

Table 6: Setting Force Valve Springs for Standard & Thick Wall inserts

	Thread Size	Material			
		Aluminum	Steel	RLT	Stainless
Thick Wall (Std & ST)	M4 8-32	-	-	DPN901-023	DPN901-023
	M5 10-24 10-32	-	DPN901-023	DPN901-023	DPN901-023
	M6 1/4-20	DPN901-023	DPN901-023	DPN901-024	DPN901-023
	M8 5/16-18	DPN901-023	DPN901-024	DPN901-024*	DPN901-024*
	M10 3/8-16	DPN901-023	DPN901-024	-	-

* Need to set tool at 0.55Mpa Minimum.

Table 7: Setting Force Valve Springs for Thin Wall inserts (TK, TL, TH)

	Thread Size	Steel
Thin Wall (TK, TL, TH)	M4 8-32	DPN901-023
	M5 10-24 10-32	DPN901-023
	M6 1/4-20	DPN901-023 / DPN901-024
	M8 5/16-18	DPN901-024
	M10 3/8-16	DPN901-024

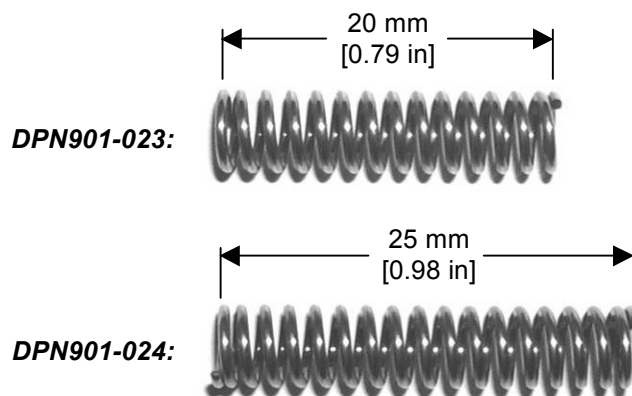

Figure 8: Valve Springs

Tool Operation

Loading the POP NUT™ onto the tool

1. Connect the air supply to the tool.
2. Thread the insert 1/4 turn onto the Mandrel.
3. Press the insert against the Mandrel as indicated and the Mandrel will spin, automatically threading the insert onto the Mandrel.
4. Keep pushing the insert onto the Mandrel until the Mandrel stops spinning. If the insert is not fully threaded, the setting stroke will be shortened by the gap between the head of the insert and the Nosepiece.

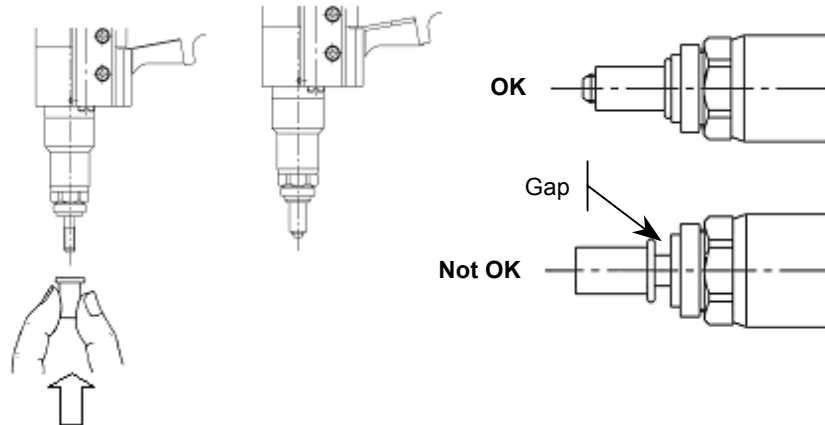

Figure 9: Loading the POP NUT™ onto tool

Installing the POP NUT™ into the work piece

1. With the POP NUT™ mounted on the Mandrel, insert it perpendicularly into the hole of the work piece
2. Pull the trigger and hold it to install the insert
3. Keep trigger depressed until the Mandrel reverses direction and completely unthreads the Mandrel from the insert.
4. Lightly pull the tool away from the work piece as Mandrel is reversing to disengage it from the insert.
5. Once the tool is disengaged from the insert, release the trigger.*

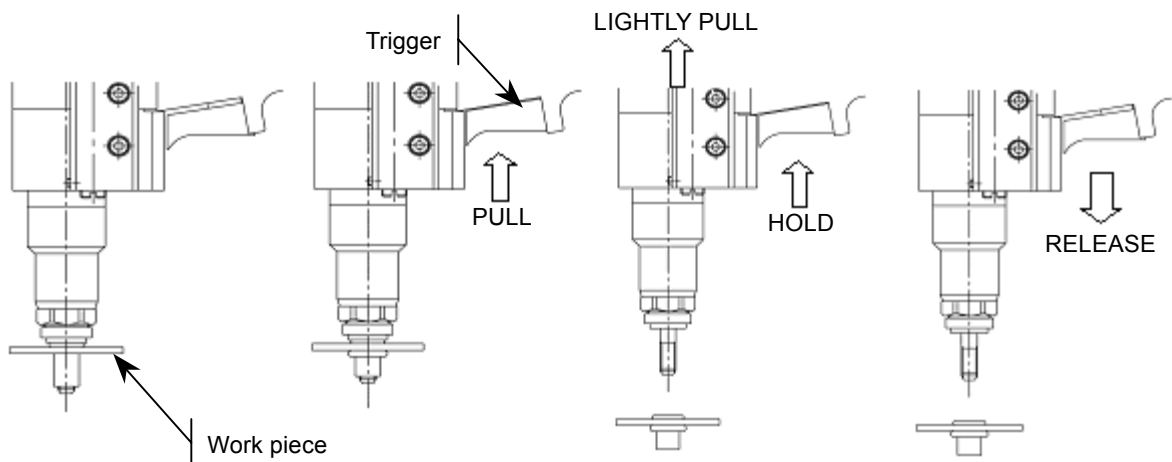

Figure 10: Setting the POP NUT™

Note:

- Fit the flange of the insert flat against the work piece.
- Do not tilt the tool. The tool must be perpendicular to the work piece.

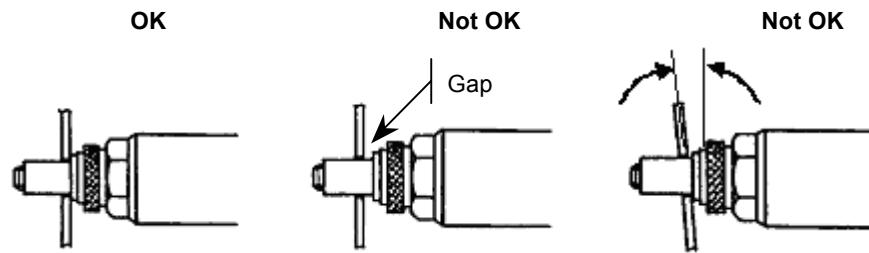

Figure 11: Proper insertion of POP NUT™ threaded inserts into an application

****Disengaging the tool from the insert***

- If you let go of the trigger during the installation sequence, the hydraulics will reset, the insert may not set completely and the tool will not unthread from the insert. Do not pull the trigger again, follow the steps below to disengage the insert.

To disengage the tool from the insert and application:

1. Depress and hold the Control Knob
2. While holding the Control Knob, press and hold the trigger. This will cause the Mandrel to spin counter-clockwise and unthread the insert.
3. When fully unthreaded, release the trigger.

To disengage the tool from the insert and work piece if the Mandrel is stuck:

1. Disconnect the air supply
2. Thread the M4 x20 Cap screw provided with the tool, into the hole in the side of the Nose Housing. Thread the Cap screw in until it fits snugly against the inner Spin Pull Head, locking the rotation of the Mandrel to the tool.
3. Turn the body of the tool counter-clockwise to detach it from the insert.

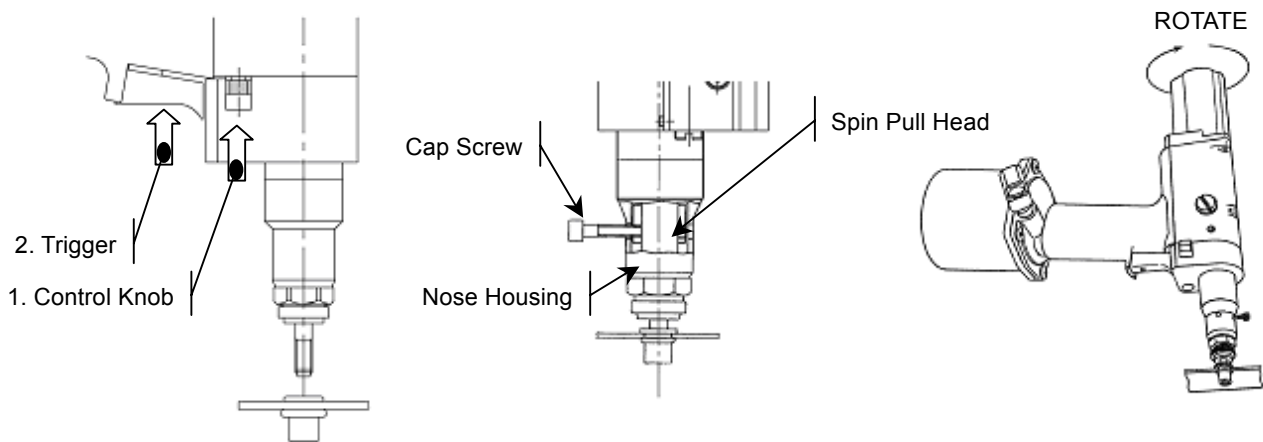

Figure 12: Disengaging the tool from the insert

Setting Force Adjustment

- Verify the proper Valve Spring is selected – See “*Setting Force Valve Spring Selection*”
- Adjust the setting force of the tool according to insert size and thickness of work piece as indicated in the instructions below.
- Test 5 pieces before beginning production work to ensure proper setting of the POP NUT™.
- Proper setting force is critical:
 - Low setting Force results in insufficient stroke and clamping of the insert, leading to a Spin Out failure in the application
 - High setting force results in excess stroke and possible insert threads stripping and Mandrel damage

Adjustment of Setting Force

The following is the procedure for adjusting the Setting Force:

1. Loosen Socket Set Screw on Setting Force Control Valve.
2. Turn the Adjuster using a flat blade screwdriver as needed.
 - a. Adjust Setting force by 1/4 turn increments to prevent stripping or damaging of insert threads.
3. Tighten Socket Set Screw on Setting Force Control Valve.

DESIRED EFFECT	ACTION
Increase Setting Force (Increases Stroke)	Rotate Adjuster Clockwise
Decrease Setting Force (Decreases Stroke)	Rotate Adjuster Counter-Clockwise

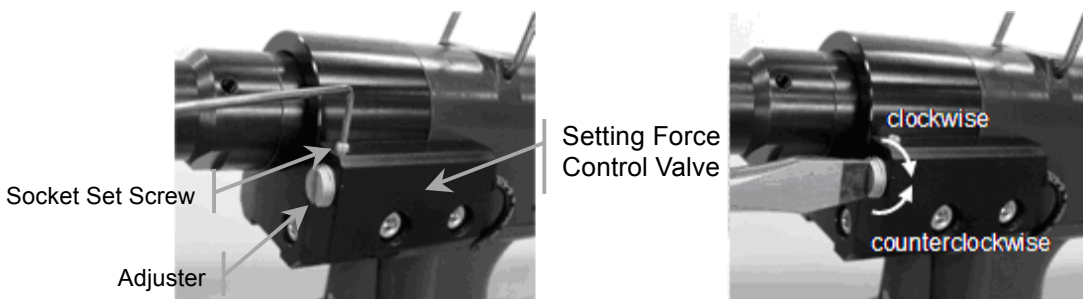

Figure 13: Adjustment of Setting Force

Note:

- The stroke may increase or decrease due to changes in air pressure [~0.1 mm (0.004 in) per 0.1 MPa (15 psi)]
- **Multiple work piece thicknesses**
 - When using the POP NUT™ tool to set the same insert in multiple work piece thicknesses, adjust the setting force to accommodate the thinnest work piece.



WARNING!

Adjust Fastening Load Control Valve by 1/4 rotations. If the Adjuster is rotated clockwise by a large amount to increase the setting force it may cause stripping or sticking of Mandrel and/or POP NUT™ threads.

Maintenance

Table 8: Maintenance Schedule

Item	Frequency	Details
Lubricate Air	1-2 drops/20 sets	<ul style="list-style-type: none"> • See "Tool Setup" • Lubricates internal seals and Air Motor
Clean & Lube Mandrel	50 sets	<ul style="list-style-type: none"> • Replace if worn/damaged • Prevents insert damage or jamming.
Inspect Nosepiece	50 sets	<ul style="list-style-type: none"> • Replace if worn/damaged • Prevents insert damage or jamming.
Lubricate rotating parts.	1000 sets	<ul style="list-style-type: none"> • Prevents loss of Mandrel rotation force.
Inspect Control Nut, T Valve Push Rod.	Mandrel breakage	<ul style="list-style-type: none"> • Replace if bent or broken
Recharge hydraulics	Loss of Stroke	<ul style="list-style-type: none"> • See "Recharging Hydraulics"

Clean & Lube Mandrel

- Clean and Lube the Mandrel every 50 sets.
 - Over time, debris can stick to the Mandrel reducing its lubrication making it difficult to mount POP NUTs™ or causing premature wear or jams.
 - Lube the Mandrel with 1 drop of oil. Use the same oil that is used with the Air Lubricator or an ISO VG 32 type oil.



Figure 14: Clean and Lube Mandrel

Lubricate Rotating Parts

- Lubricate the Spin Pull Head and Spin Pull Head Case after approximately every 1000 sets.
 - Lack of lubrication will cause increase internal friction causing premature wear and reducing the Mandrel rotation speed and torque

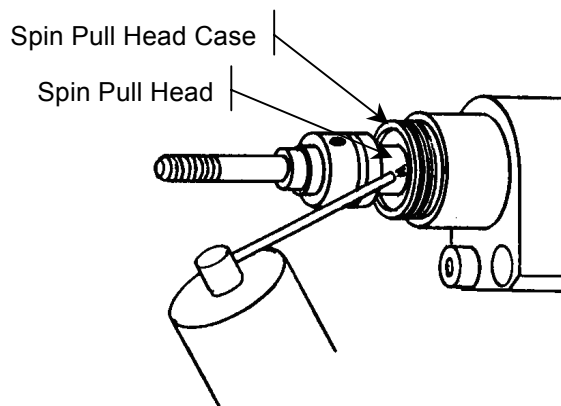

Figure 15: Lubricating the Spin Pull Head

Recharging Hydraulics

- If the stroke gets too short and the tool is unable to properly set an insert the Hydraulic Oil may need to be recharged.

Note: If the stroke is still inadequate after recharging, the Hydraulic Seals may need to be replaced. Contact your local distributor for tool repair.

Recharging Procedure

1. Disconnect the air supply
2. Remove Air Tube from the fitting in the Chamber
3. Remove the four (4) truss head machine screws attaching the Chamber to the Handle Lower
4. Turn the tool upside down and slowly remove the Chamber from the tool
5. Remove the Air Piston Assembly and the Tube

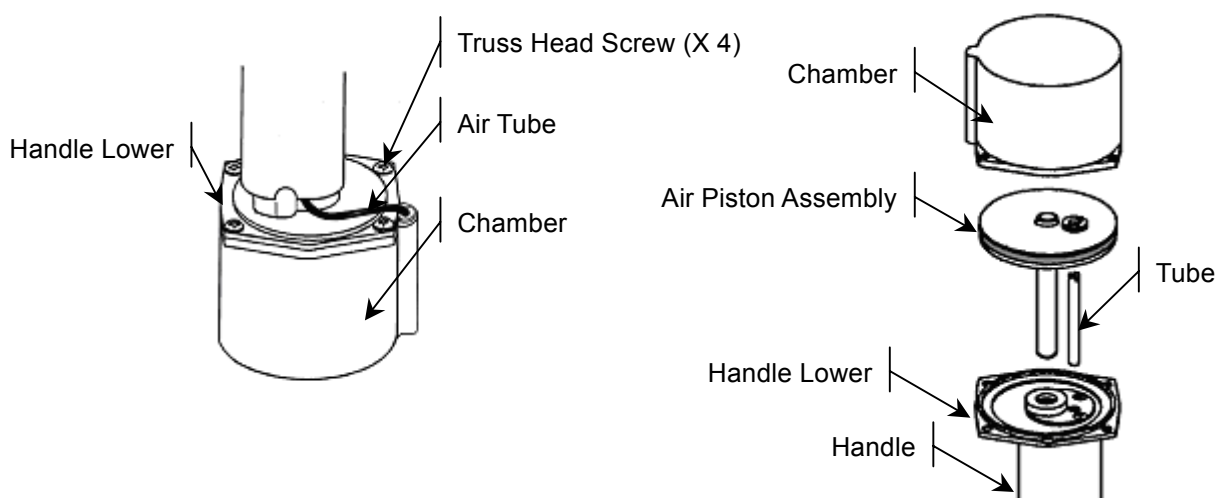

Figure 16: Removing the Chamber and Air Piston Assembly

6. Dispose of the old hydraulic oil in a proper waste oil container
 7. Pour the new hydraulic oil into the bore of the handle until the oil is level with the Back-up Ring
- Note:** Use only Emhart approved Hydraulic Oils – See Table 3, “*Specified Hydraulic Oils*”

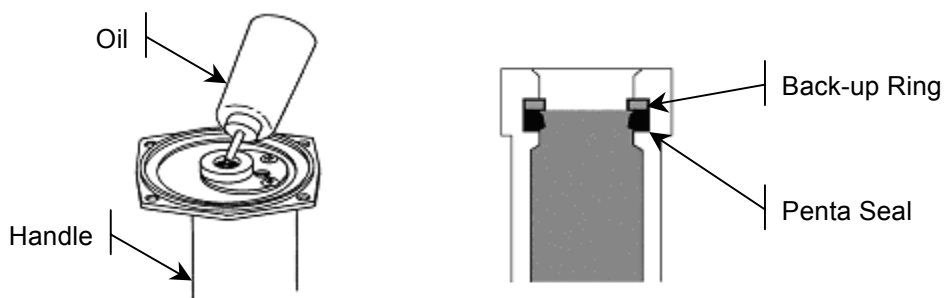

Figure 17: Re-filling Hydraulic Oil

8. Replace the Air Piston Assembly and push it into the Handle slowly, 5 times, and then remove it
9. Check to see if the oil level has fallen or if there are air bubbles present in the oil
10. If the oil level has dropped or air bubbles are present, repeat steps 7 thru 9

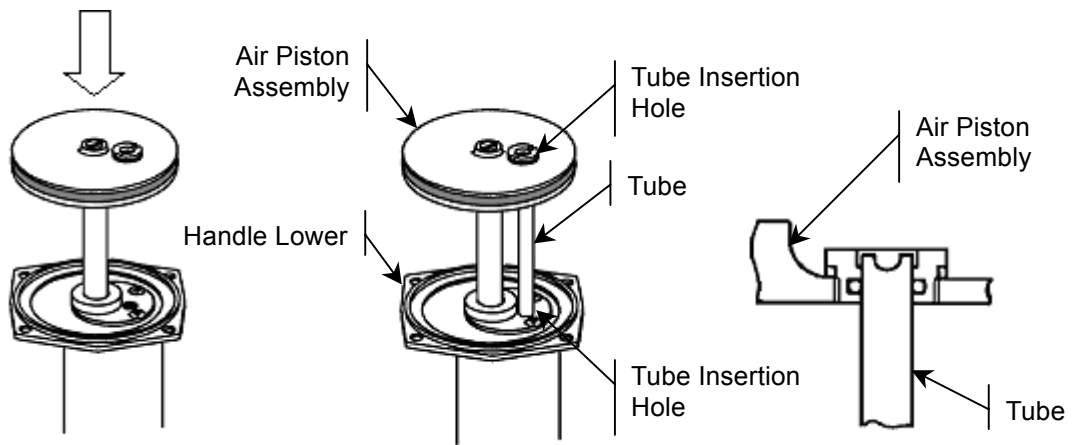

Figure 18: Recharging and purging air bubbles

11. After replacement of the hydraulic oil, line up the Air Piston Assembly and the Tube Insertion Hole in the Handle Lower and push the Tube into place.
12. Pass the Tube into the tube insertion holes in the Air Piston Assembly and the Handle Lower
13. Replace the Chamber and the four (4) truss head machine screws and tighten
14. Place the tool on its side so that the Fill Screw is uppermost.
15. Use a flat bladed screwdriver to unscrew the fill screw to let any excess oil and air (bubbles) escape.
16. Once the hydraulic oil stops coming out, tighten the Fill Screw

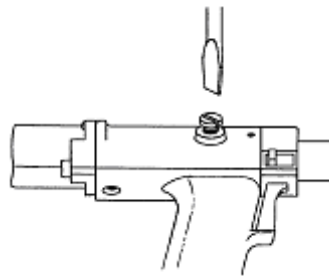

Figure 19: Purging excess oil

Troubleshooting

If you are unable to fix the tool after reviewing this manual and the troubleshooting section, contact your distributor or Emhart Teknologies for repair.

Problem	Cause	Action	Section
Cannot thread the POP NUT™ onto Mandrel	Incorrect Mandrel and Nosepiece	Change to the correct parts for the POP Nut you are using.	Specifications, Table 5
	Mandrel threads are damaged.	Replace the Mandrel	Tool Setup, Mandrel and Nosepiece installation
	Metal chip are jammed in Mandrel's threads.	Clean and lube the Mandrel	Maintenance
No forward or reverse rotation of the Mandrel. (Slow rotation)	Low air pressure.	Adjust the air supply to the correct pressure range	Tool Setup
	Insufficient Lubricant.	Adjust the Lubricator drip rate.	Tool Setup
	Insufficient Lubricant in the rotating parts.	Lubricate the rotating parts	Maintenance
	After installation, the tool is still threaded into the insert and work piece	Disengage the tool from the workpiece using the Control Knob	Tool Operation
The Mandrel cannot unthread from the insert	The insert threads have been damaged due to high setting force	Disengage the tool from the work piece	Tool Operation
		Adjust the setting force correctly	Setting Force Adjustment
	Mandrel threads are damaged.	Replace the Mandrel	Tool Setup, Mandrel and Nosepiece installation
Unthreading sequence stopped during automatic reverse	Trigger was released while detaching the tool (before unthreading was complete)	Disengage the tool from the workpiece using the Control Knob	Tool Operation
		Review the proper operating procedure	Basic Tool Operation
The insert is not fully set, stroke is incomplete	Low air pressure.	Adjust the air supply to the correct pressure range	Tool Setup
	Too little hydraulic oil.	Recharge the hydraulic oil	Maintenance
The tool automatically reverse rotates	Too much hydraulic oil or air is mixed in hydraulic oil	Recharge the hydraulic oil	Maintenance
The tool does not reverse rotate automatically	Low air pressure	Adjust the air supply to the correct pressure range	Tool Setup
	Too little hydraulic oil or air is mixed in hydraulic oil.	Recharge the hydraulic oil	Maintenance

Problem	Cause	Action	Section
The Mandrel is damaged, and/or broken	Life of the Mandrel	Replace the Mandrel	Tool Setup, Mandrel and Nosepiece installation
	The setting force is excessive	Adjust the setting force correctly	Setting Force Adjustment
		Replace the damaged parts	Tool Setup, Mandrel and Nosepiece installation
Tool is not perpendicular to the work piece during installation		Review the proper operating procedure	Basic Tool Operation
		Replace the damaged parts	Tool Setup, Mandrel and Nosepiece installation
Tool cannot be adjusted to achieve a proper installation	Too little hydraulic oil	Recharge the hydraulic oil	Maintenance
	Too much hydraulic oil or air is mixed in hydraulic oil	Recharge the hydraulic oil	Maintenance

Safety Data

SEAL LUBE (P/N: PSA075508P)

LUBRIPLATE® 130-AA

Manufactured by:
Fiske Brothers Refining Co.
Phone: (419) 691-2491
Emergency: (800) 255-3924

ALVANIA® EP Grease 1

Prod Code: 71124
Manufactured by:
Shell Oil Products
Phone: (877) 276-7285
MSDS#: 57072E-5

First Aid:

SKIN:
Remove any contaminated clothing and wash with soap and warm water. If injected by high pressure under skin, regardless of the appearance of its size, contact a physician IMMEDIATELY.
Delay may cause loss of affected part of body.

INGESTION:

Call a physician immediately. Do not induce vomiting.

EYES:

Flush with clear water for 15 minutes or until irritation subsides. If irritation persists, consult a physician.

Fire:

FLASH POINT: COC- 400°F
Cool exposed containers with water.
Use foam, dry chemical, carbon dioxide or water spray.

Environment:

WASTE DISPOSAL:

Assure conformity with applicable disposal regulations.
Dispose of absorbed material at an approved waste disposal facility or site.

SPILLAGE:

Scrape up grease, wash remainder with suitable petroleum solvent or add absorbent.

Handling/ Storage:

Keep containers closed when not in use. Do not handle or store near heat, sparks, flame or strong oxidants.

Lubriplate® is a registered trademark of Fiske Brothers Refining Company.

Please refer to the actual MSDS for complete safety and handling information. These can be obtained from

HYDRAULIC OIL (P/N: PRG540-130)

MOBIL DTE 26

Manufactured By:

ExxonMobil Corporation

Emergency Phone: (609) 737-4411

MSDS Fax on Demand:

(613) 228-1467 MSDS # 602649-00

Shell TELLUS 68

Manufactured By:

SOPUS Products

Health Information: (877) 504-9351

MSDS Assistance:

(877) 276-7285 MSDS # 402288L-0

Distributed By:

Emhart Teknologies

Phone: (203) 924-9341

First Aid:

SKIN:

Remove contaminated clothing and shoes and wipe excess from skin. Flush skin with water, then wash with soap and water. If irritation occurs, get medical attention.

INGESTION:

Do not induce vomiting. In general, no treatment is necessary unless large quantities of product are ingested. However, get medical attention.

EYES:

Flush with water. If irritation occurs, get medical attention.

Fire:

FLASH POINT: 390° F/198.9° C

Material will float and can be re-ignited on the surface of water. Use water fog, 'alcohol foam', dry chemical or carbon dioxide (CO₂) to extinguish flames. Do not use a direct stream of water.

Environment:

SPILLAGE:

Soak up residue with an absorbent such as clay, sand or other suitable material. Place in a non-leaking container and seal tightly for proper disposal.

Handling:

Wash with soap and water before eating, drinking, smoking, applying cosmetics or using toilet. Properly dispose of leather articles such as shoes or belts that cannot be decontaminated. Use in a well ventilated area.

Storage:

Store in a cool, dry place with adequate ventilation. Keep away from open flames and high temperatures.

EC Declaration of Conformity

We, Emhart Teknologies

Tucker Fasteners Limited
Birmingham B42 1BP
United Kingdom.

Declare that:

PNT800L-PC

Conforms to the following standards:

EN 292 part 1 and part 2
ISO 3744
ISO prEN 792 part 1
EN ISO 4871

ISO prEN 15744
EN 28662 - 1
EN 12096

Following the provisions of the Machine Directive 98/37/EEC which replaces Directive 89/392/EEC and it's amending Directives 91/368/EEC, 93/44/EEC and 93/68/EEC.



Signed: _____

Eymard Chitty, Vice President, R&D

Birmingham
June, 2008

EUROPE

United Kingdom
Emhart Teknologies
Tucker Fasteners
177 Walsall Road
Birmingham, B42 1BP
United Kingdom
Tel: +44 121 356 4811
Fax: +44 121 356 1598
csduk@bdk.com

The Netherlands
Emhart Teknologies
P.O. Box 514
6190 BA Beek
Europalaan 12
6199 AB Maastricht-Airport
The Netherlands
Tel: +31 43 750 2020
Fax: +31 43 750 2030

Spain
Emhart Teknologies
Sistemas de Fijacion Tucker
Carretera M-300
KM. 29,700
28802 Alcalá de Henares
Madrid, Spain
Tel: +34 91 887 1470
Fax: +34 91 882 3602
sft.pedidos@bdk.com

France
Emhart Teknologies
Emhart Fastening & Assembly
S.N.C.
ZA des Petits Carreaux
2 Bis Avenue des Coquelicots
94835 Bonneuil-sur-Marne
Cedex, France
Tel: +33 1 56 71 24 37
Fax: +33 1 49 80 42 93
csdfr@bdk.com

Germany
Emhart Teknologies
Tucker Fasteners GmbH
Max-Eyth-Strasse 1
D-35394 Giessen
Germany
Tel: +49 641 405 0
Fax: +49 641 405 366
pop.de@bdk.com

Norway
Emhart Teknologies
Emhart Sjong
PO Box 203
Sjútubanevägen 6
S-701 44 Örebro
Sweden
Tel: +47 22 90 99 00
Fax: +46 19 26 00 38
info@emhart-teknik.se

Denmark
Emhart Teknologies
Emhart Harttung A/S
Farverland 1B
DK-2600 Glostrup
Denmark
Tel: +45 44 84 11 00
Fax: +45 44 84 62 12
salg.danmark@bdk.com

Sweden
Emhart Teknologies
Emhart Teknik AB
PO Box 203
Sjútubanevägen 6
S-701 44 Örebro
Sweden
Tel: +46 19 20 58 00
Fax: +46 19 26 00 38
info@emhart-teknik.se

Finland
Emhart Teknologies
Emhart Finland
Hyttimestarinkuja 4 PL 25
FI-02781, Espoo
Finland
Tel: +358 9 819 0060
Fax: +358 9 812 428
myynti.emhart@bdk.com

Czech Republic
Emhart Teknologies
Tucker s.r.o.
Tel: +420 725 800 454
Fax: +420 493 546 567

Poland
Emhart Teknologies
Tel: +48 661 233 304
Fax: +48 32 749 70 75

AMERICAS

USA - Connecticut
Emhart Teknologies
4 Corporate Drive, Suite 395
Shelton, CT 06484
USA
Tel: +1 203 925 2260
Fax: +1 203 925 2279

Canada
Emhart Teknologies
9870 Boulevard Du Golf
Anjou, Quebec
Canada H1J 2Y7
Tel: +1 514 351 0330
Fax: +1 514 351 0458

Mexico
Emhart Teknologies
Bosque De Cidros
Acceso Radiatas No 42
Bosque De Las Lomas,
3a Seccion, Mexico City
Mexico DF 05120
Tel: +52 55 5326 7100
Fax: +52 55 5236 7141

Brazil
Emhart Teknologies
Emhart Refal
Rua Ricardo Cavatton, 226
CEP: 05038-110 São Paulo
Brazil
Tel: +52 55 11 3871 6460
Fax: +52 55 11 3611 3505

ASIA

China
Emhart Teknologies
Shanghai Emhart Fastening
Systems
488 Jialou Road
Jaiding District
Shanghai 201807, China
Tel: +86 21 5954 8626
Fax: +86 21 5954 8775

Japan
Emhart Teknologies
Shuwa Kioicho Park Building 302
3-6 Kioicho, Chiyoo-Ku
Tokyo, 1020094, Japan
Tel: +81 3 3265 7291
Fax: +81 3 3265 7298

Korea
Emhart Teknologies
Seorin Building
45-15 Yeoido-Dong
Yeongdeungpo-Ku
Seoul, 150-891, R.O. Korea
Tel: +82 2 783 9226
Fax: +82 2 783 9228

India
Emhart Teknologies
APEX Towers, 5th Floor
No 54, 2nd Main Road
R.A. Puram, Chennai- 600028
India
Tel: +91 44 4306 0639
Fax: +91 44 4306 0768