

# TITAN

PXA270 RISC based PC/104  
Single Board Computer

Rev. 4.0 - April 2009 - ETH\_TITAN\_USM

## DISCLAIMER

The information in this document is subject to change without notice and should not be construed as a commitment by any Eurotech company. While reasonable precautions have been taken, Eurotech assumes no responsibility for any error that may appear in this document.

## WARRANTY

This product is supplied with a 3 year limited warranty. The product warranty covers failure of any Eurotech manufactured product caused by manufacturing defects. The warranty on all third party manufactured products utilised by Eurotech is limited to 1 year. Eurotech will make all reasonable effort to repair the product or replace it with an identical variant. Eurotech reserves the right to replace the returned product with an alternative variant or an equivalent fit, form and functional product. Delivery charges will apply to all returned products. Please check [www.eurotech.com](http://www.eurotech.com) for information about Product Return Forms.

## TRADEMARKS

ARM and StrongARM are registered trademarks of ARM Ltd.

Intel and XScale are trademarks or registered trademarks of Intel Corporation or its subsidiaries in the United States and other countries.

Windows CE is a trademark of the Microsoft Corporation.

CompactFlash is the registered trademark of SanDisk Corp.

Linux is a registered trademark of Linus Torvalds.

RedBoot and Red Hat™ is a registered trademark of Red Hat Inc.

Bluetooth is a registered trademark of Bluetooth SIG, Inc.

All other trademarks recognised.

## REVISION HISTORY

<i>Issue no.</i>	<i>PCB</i>	<i>Date</i>	<i>Comments</i>
A	V0 Issue 2	30 <sup>th</sup> August 2007	Draft release of manual for TITAN and TITAN-Lite.
B	V0 Issue 2	1 <sup>st</sup> October 2007	Moved ZEUS-FPIF and Ethernet Breakout details to Appendices and added details of ZEUS-FPIF-CRT; Eurotech rebranding.
C	V1 Issue 1	16 <sup>th</sup> April 2008	Release for TITAN V1I1.
D	V1 Issue 1	2 <sup>nd</sup> April 2009	Minor updates and new branding.

© 2009 Eurotech. All rights reserved.

For contact details, see page [101](#).

## Contents

Introduction.....	5
TITAN ‘at a glance’ .....	6
TITAN features .....	7
TITAN support products.....	10
Product handling and environmental compliance.....	11
Conventions.....	12
Getting started .....	13
Using the TITAN .....	13
Detailed hardware description .....	15
TITAN block diagram .....	15
TITAN address map.....	16
Translations made by the MMU.....	17
PXA270 processor.....	17
PXA270 GPIO pin assignments .....	19
Interrupt assignments .....	24
Real time clock .....	25
Watchdog timer.....	26
Memory.....	27
SDIO.....	28
PC/104 interface.....	29
Flat panel display support.....	36
Audio .....	42
Touchscreen controller .....	42
USB .....	43
Ethernet.....	45
Serial COMs ports .....	46
I <sup>2</sup> C.....	50
Quick Capture camera interface.....	51
General purpose I/O.....	52
Temperature sensor.....	52
JTAG and debug access .....	53
Power and power management.....	54
Power supplies .....	54
Processor power management.....	57
Peripheral devices power management .....	59
Connectors, LEDs and jumpers.....	64
Connectors .....	65
Status LEDs.....	78
Jumpers .....	78
Appendix A - Board version / issue .....	82
Appendix B - Specification .....	84
Appendix C - Mechanical diagram.....	86
Appendix D - Reference information .....	87
Appendix E - ZEUS-FPIF details .....	88
Appendix F - ZEUS-FPIF-CRT details .....	93

Appendix G - Ethernet Breakout details.....	96
Appendix H - Acronyms and abbreviations .....	98
Appendix I - RoHS-6 Compliance - Materials Declaration Form.....	100
Eurotech Group Worldwide Presence.....	101

## Introduction

The TITAN is an ultra low power PC/104 compatible single board computer based on the Intel 520MHz PXA270 XScale processor. The PXA270 is an implementation of the Intel XScale micro architecture combined with a comprehensive set of integrated peripherals, including:

- Flat panel graphics controller.
- Interrupt controller.
- Real time clock.
- Various serial interfaces.

The TITAN board offers a wide range of features making it ideal for power sensitive embedded communications and multimedia applications.

The board is available in two standard variants:

- TITAN.
- TITAN-Lite (TITANL).

The TITAN is available with a choice CPU frequency and memory configurations options, as shown below:

Variant	Memory configuration	Details
TITAN	TITAN-FRx-Mx-Fx-R6	PXA270, FRx=520/416MHz microprocessor, Mx=64/128MB SDRAM, Fx=32/64MB Flash, Commercial temperature range.
	TITAN-FRx-Mx-Fx-I-R6	PXA270, FRx=520/416MHz microprocessor, Mx=64/128MB SDRAM, Fx=32/64MB Flash, Industrial temperature range.
TITAN-Lite	TITANL-312-M64-F16-R6	PXA270 312MHz CPU, 64MB SDRAM, 16MB Flash No SRAM, PC/104, Audio or COM 4 & 5, Commercial temperature range.
	TITANL-312-M64-F16-I-R6	PXA270 312MHz CPU, 64MB SDRAM, 16MB Flash No SRAM, PC/104, Audio or COM 4 & 5, Industrial temperature range.

The TITAN board is RoHS compliant.

For alternative memory configurations, please contact Eurotech (see [Eurotech Group Worldwide Presence](#), page 101, for details). Eurotech can provide custom configurations (subject to a minimum order quantity) for the TITAN / TITAN-Lite. Please contact our Sales team to discuss your requirements.

### TITAN 'at a glance'

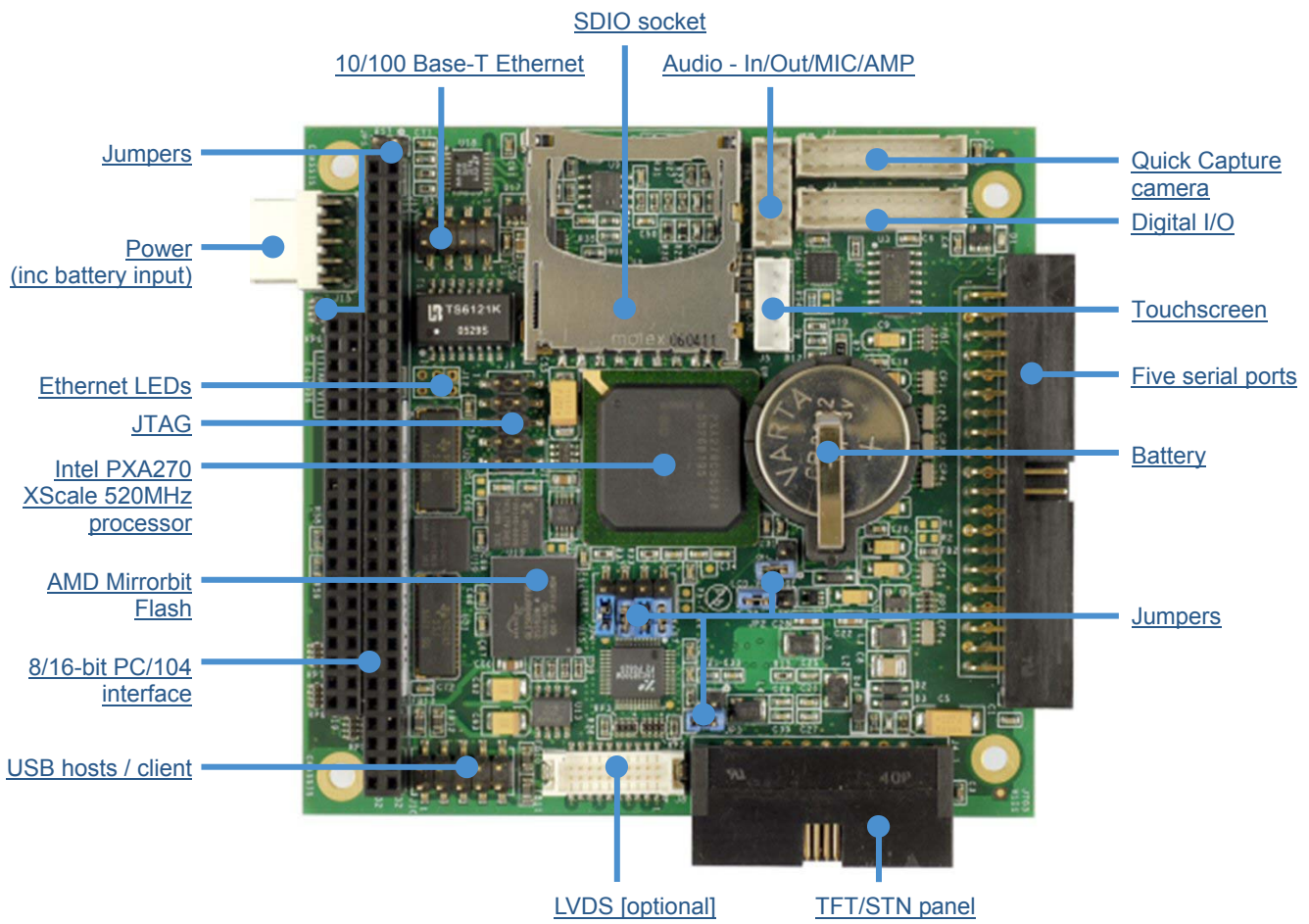

## TITAN features

### Microprocessor

-  PXA270 312MHz (TITAN-Lite only) 416/520MHz XScale processor (520MHz as standard option).

### Cache

- 32K data cache, 32K instruction cache, 2K mini data cache.

### System memory

- Fixed on-board memory: 64/128MB SDRAM (32-bit wide SDRAM data bus).

### Silicon disk

- Fixed on-board memory: 16MB Flash (TITAN-Lite only) or 32/64MB Flash.



### SRAM

-  256KB of SRAM battery backed on-board.

### Serial ports

- Five UART fast serial ports, 16550 compatible (921.6Kbaud):
  - One RS422/485 interface (software selectable).
  - Four RS232 interfaces.
- Two channels with 128 byte Tx/Rx FIFO.
- 40-pin boxed header.

### USB support

-  Two USB 1.1 host controller ports supporting 12Mbps and 1.5Mbps speeds.
- One USB 1.1 client controller port supporting 12Mbps and 1.5Mbps speeds (software selectable on Host 2).
-  Short circuit protection with 500mA current limit protection.
- 10-pin header.

### Network support

- One IEEE 802.3u 10/100 Base-T Ethernet controller.
- One 10/100BaseTX NIC port on 8-pin header.
- Factory build option for external Power-over-Ethernet (PoE).



### Expansion interfaces

- SDIO socket to support MMC/SD/SDIO cards.
- PC/104 expansion bus - 8/16-bit ISA bus compatible interface.



## Date/time support

- Real time clock – battery backed on-board (external to PXA270).
- ± 1 minute/month accuracy.

## Video

- 18-bit flat panel interface for STN and TFT displays on 40-pin boxed connector.
- Up to 800x600 resolution.
- 8/16bpp.
- Backlight control.
-  • Optional LVDS interface.
- LCD voltage (3.3V / 5V) selection jumper.
-  • LVDS encoding mode selector jumper (for signalling decoding LVDS display receiver).

## Audio and touchscreen

-  • Wolfson WM9712L AC'97 compatible CODEC.
-  • Line in, line out, microphone in, stereo amp out on 12-pin boxed header.
-  • Touchscreen support: 4/5-wire analogue resistive on 5-pin boxed header.

## Quick Capture camera interface

- Intel® Quick Capture technology.
- 20-pin boxed header connector to a camera image sensor.

## I<sup>2</sup>C bus

- Multi-master serial bus, header connection.

## Configuration PROM

- I<sup>2</sup>C PROM for storing configuration data.

## Watchdog timer

- External to PXA270, generates reset on timeout. Timeout range 1ms-60s.

## User configuration

- Three user configurable jumpers on 8-pin header.

## General I/O



- Sixteen user configurable general purpose I/O on 20-pin boxed header.
- 5V tolerant inputs.
- 3.3V outputs, pulled up to 5V.
- PWM outputs for LED intensity control



### Temperature sensor

- I<sup>2</sup>C temperature sensor.

### Battery backup

-  On-board battery holder containing a lithium-ion non-rechargeable CR2032, 3V, 220mAh battery.
-  Battery disconnect jumper.

### Test support

- JTAG interface (10-pin header).
- Download data to FLASH memory.
- Debug and connection to In-Circuit Emulator (ICE).

### Power requirements

- Typically 1.5W from a single 5V supply.
- Power management features allow current requirements to be as low as 20mA (100mW) in sleep mode and 2mA (10mW) in deep sleep mode.

### Mechanical

- PC/104 compatible footprint 3.8" x 3.6" (96mm x 91mm) [www.pc104.org/](http://www.pc104.org/)

### Environmental

- Operating temperature:
  - Commercial: 20°C (-4°F) to +70°C (+158°F) for speed variants up to 520MHz.
  - Industrial: -40°C (-40°F) to +85°C (+185°F) for speed variants up to 416MHz.
- RoHS Directive Compliant (2002/95/EC).

## TITAN support products

The following products support the TITAN:

- **ZEUS-FPIF (Flat Panel Interface)**  
The ZEUS-FPIF is a simple board that enables easy connection between the TITAN and a variety of LCD flat panel displays.  
See [Appendix E - ZEUS-FPIF details](#), page [88](#), for further details.
- **ZEUS-FPIF-CRT**, a board that allows the TITAN to drive a CRT monitor or an analogue LCD flat panel. Sync on green and composite sync monitors are not supported.  
See [Appendix F - ZEUS-FPIF-CRT details](#), page [93](#), for further details.
- **ETHER-BREAKOUT**  
The ETHER-BREAKOUT is a simple board that converts the TITAN Ethernet 8-pin header and Ethernet LEDs 6-pin header to a standard RJ45 connector with LEDs.  
See [Appendix G - Ethernet Breakout details](#), page [96](#), for further details.

Contact Eurotech (see [Eurotech Group Worldwide Presence](#), page [101](#)) for further information about any of these products.

## Product handling and environmental compliance

### Anti-static handling

This board contains CMOS devices that could be damaged in the event of static electricity being discharged through them. At all times, please observe anti-static precautions when handling the board. This includes storing the board in appropriate anti-static packaging and wearing a wrist strap when handling the board.

### Packaging

Please ensure that, should a board need to be returned to Eurotech, it is adequately packed (preferably in the original packing material).

### Electromagnetic compatibility (EMC)

The TITAN is classified as a component with regard to the European Community EMC regulations and it is the user's responsibility to ensure that systems using the board are compliant with the appropriate EMC standards.







### RoHS compliance

The European RoHS Directive (Restriction on the Use of Certain Hazardous Substances – Directive 2002/95/EC) limits the amount of six specific substances within the composition of the product. The ZEUS and associated accessory products are available as RoHS-6 compliant options and are identified by an -R6 suffix in the product order code. A full RoHS Compliance Materials Declaration Form is included in [Appendix I - RoHS-6 Compliance - Materials Declaration Form](#). Further information about RoHS compliance is available on the Eurotech web site at [www.eurotech-ltd.co.uk/RoHS\\_and\\_WEEE](http://www.eurotech-ltd.co.uk/RoHS_and_WEEE).

## Conventions

The following symbols are used in this guide:

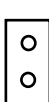
Symbol	Explanation
	Note - information that requires your attention.
	Caution – proceeding with a course of action may damage your equipment or result in loss of data.
	Jumper is fitted.
	Jumper provided, but not fitted.
	Jumper is not fitted.

## Tables

With tables such as that shown below, the white cells show information relevant to the subject being discussed. Grey cells are not relevant in the current context.

Byte lane	Most significant byte								Least significant byte								
Bit	15	14	13	12	11	10	9	8	7	6	5	4	3	2	1	0	
Field	-	-	-	-	-	-	-	-	-	-	-	-	-	-	RETR <sub>I</sub>	AUTO CLR	R_DIS
Reset	X	X	X	X	X	X	X	X	0	0	0	0	0	0	0	0	0

## Getting started

---

Depending on the Development Kit purchased, a Quickstart Manual is provided for Windows CE or embedded Linux to enable users to set up and start using the board. Please read the relevant manual and follow the steps for setting up the board. Once you have completed this task and have a working TITAN system, you can start adding further peripherals, enabling development to begin.

### Using the TITAN

This section provides a guide to setting up and using of some of the features of the TITAN. For more detailed information on any aspect of the board see [Detailed hardware description](#), page 15.

### Using the SDIO socket

The TITAN is fitted with a SDIO socket mounted on the top side of the board. The socket is connected to a PXA270 MMC/SD/SDIO controller interface. The TITAN supports hot swap changeover of the cards and notification of card insertion. See the sections [SDIO](#), page 28, and [J7 – SDIO socket](#), page 70, for further details.

### Using the serial interfaces (RS232/422/485)

The five serial port interfaces on the TITAN are fully 16550 compatible. Connection to the serial ports is made via a 40-way boxed header. The pin assignment of this header has been arranged to enable 9-way IDC D-Sub plugs to be connected directly to the cable. See the sections [Serial COMs ports](#), page 46, and [J1 – COMS ports](#), page 66, for further details.

A suitable cable for COM1 is provided as part of the Development Kit. The D-Sub connector on this cable is compatible with the standard 9-way connector on a desktop computer.



---

COM4 (RS232) and COM5 (RS422/485) are not available on the standard TITAN-Lite configuration. Eurotech can provide custom configurations (subject to a minimum order quantity) for the TITAN-Lite populated with this feature. Please contact our Sales team to discuss your requirements (see [Eurotech Group Worldwide Presence](#), page 101).

---

### Using the audio features



There are four audio interfaces supported on the TITAN: amp out, line out, line in and microphone. The line in, line out and amp interfaces support stereo signals and the microphone provides a mono input. The amplified output is suitable for driving an 8Ω load with a maximum power output of 250mW per channel.

Connections are routed to J6 - see the sections [Audio](#), page 41, and [J7 – Audio connector](#), page 69, for further details.

## Using the USB host



The standard USB connector is a 4-way socket, which provides power and data signals to the USB peripheral. The 10-way header J10 has been designed to be compatible with PC expansion brackets that support two USB sockets. See the sections [USB](#), page 43, and [J10 – USB connector](#), page 72, for further details.

## Using the USB client

The TITAN USB host port 2 can be configured under software to be a client and connected to a PC via a USB cable. This feature is standard for the TITAN-Lite. The USB cable should be plugged into the 10-way header J10. See the sections [USB](#), page 43, and [J10 – USB connector](#), page 72, for further details.

## Using the Ethernet interface

The Davicom DM9000A 10/100BaseTX Ethernet controller is configured by the RedBoot boot loader for embedded Linux, and by Windows CE once it has booted. Connection is made via connector J11. A second connector J12 provides link and speed status outputs for control LEDs. See the sections [Ethernet](#), page 45; [J11 – 10/100BaseTX Ethernet connector](#), page 72; and [J12 – Ethernet status LEDs connector](#), page 73, for further details.

## Using the PC/104 expansion bus



PC/104 modules can be used with the TITAN to add extra functionality to the system. This interface supports 8/16-bit ISA bus style peripherals.

Eurotech has a wide range of PC/104 modules that are compatible with the TITAN. These include modules for digital I/O, analogue I/O, motion control, video capture, CAN bus, serial interfaces, etc. Please contact the Eurotech sales team if a particular interface you require does not appear to be available as these modules are in continuous development. Contact details are provided in [Eurotech Group Worldwide Presence](#), page 101.

To use a PC/104 board with the TITAN, plug it into J13 for 8-bit cards and J13/J14 for 8/16-bit cards. See the sections [PC/104 interface](#), page 29, and [J14 & J15 – PC/104 connectors](#), page 74, for further details.

The ISA interface on the TITAN does not support DMA, shared interrupts and some access modes. See the section [PC/104 interrupts](#), page 30, for details about PC/104 interrupt use.

The TITAN provides +5V to a PC/104 add-on board via the J13 and J14 connectors. If a PC/104 add-on board requires a +12V supply, then +12V must be supplied to the TITAN power connector J15 pin 4. If –12V or –5V are required, these must be supplied directly to the PC/104 add-on board.

The TITAN is available with non-stack through connectors by special order. Contact Eurotech for more details (see [Eurotech Group Worldwide Presence](#), page 101).

# Detailed hardware description

The following section provides a detailed description of the functions provided by the TITAN. This information may be required during development after you have started adding extra peripherals or are starting to use some of the embedded features.

## TITAN block diagram

The diagram below illustrates the functional organization of the TITAN and TITAN-Lite PC/104 SBC:

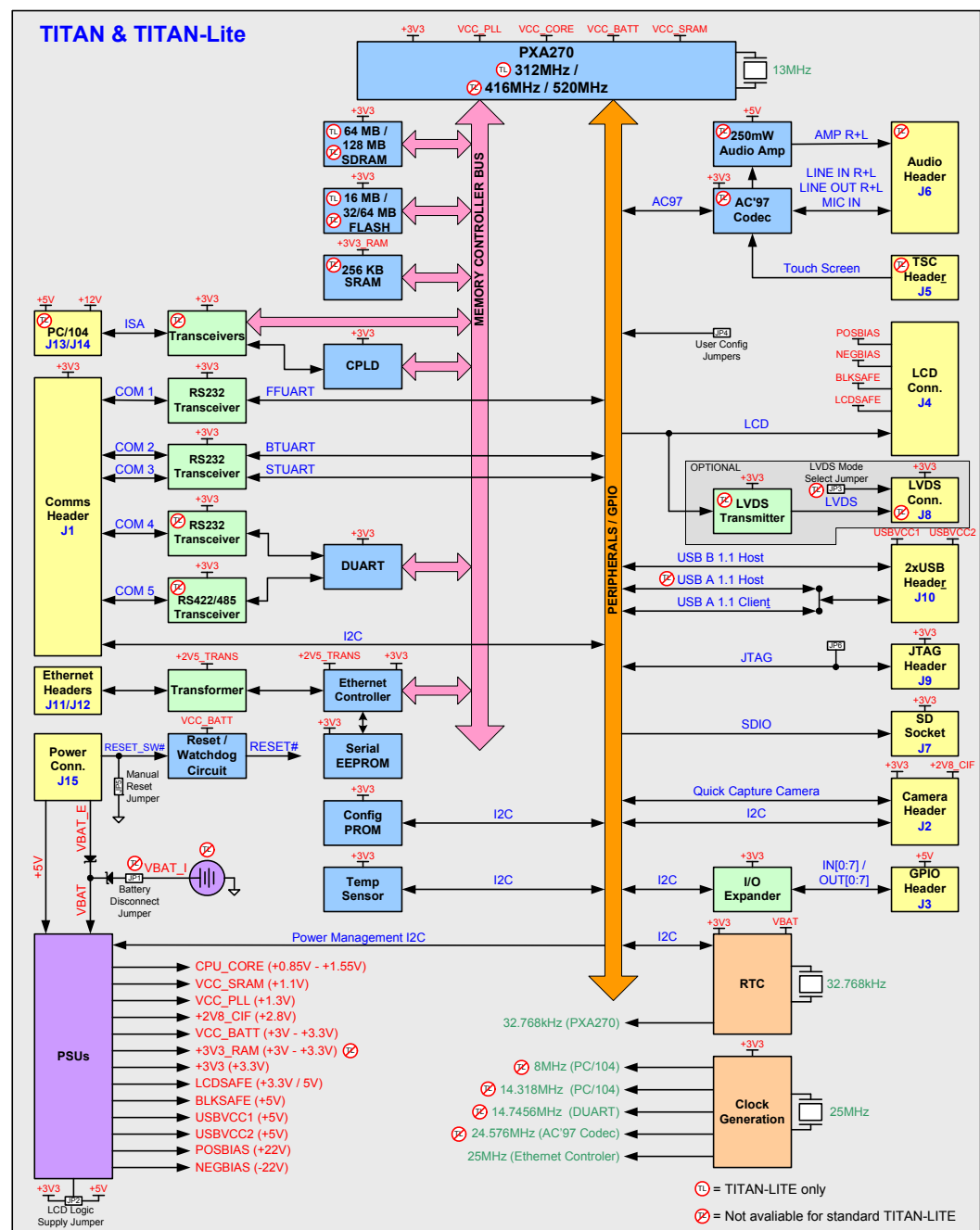

## TITAN address map

PXA270 chip select	Physical address	Bus width	Description
CS0#	0x00000000 – 0x03FFFFFFE	16-bit	FLASH memory / Silicon disk
CS1#	0x04000000 – 0x07FFFFFFE	16-bit	Ethernet controller
-	0x08000000 – 0x0FFFFFFF	-	Reserved
ⓧ CS4#	0x10000000 – 0x1000000E	16-bit	COM4
-	0x10000010 – 0x107FFFFFFF	-	Reserved
CS4#	0x10800000 – 0x1080000E	16-bit	COM5
-	0x10800010 – 0x10FFFFFFF	-	Reserved
CS4#	0x11000000 – 0x11000001	16-bit	BV_REG (Board version / issue)
-	0x11000002 – 0x117FFFFFFF	-	Reserved
CS4#	0x11800000 – 0x11800001	16-bit	I2_REG (PC104 IRQ status)
-	0x11800002 – 0x11FFFFFFF	-	Reserved
CS4#	0x12000000 – 0x12000001	16-bit	CV_REG (CPLD version / issue)
-	0x12000002 – 0x127FFFFFFF	-	Reserved
CS4#	0x12800000 – 0x12800001	16-bit	I1_REG (PC104 IRQ status)
-	0x12800002 – 0x12FFFFFFF	-	Reserved
CS4#	0x13000000 – 0x13000001	16-bit	C_REG (PC104 reset)
-	0x13000002 – 0x13FFFFFFF	-	Reserved
ⓧ CS5#	0x14000000 – 0x17FFFFFFE	16-bit	SRAM
-	0x18000000 – 0x1FFFFFFF	-	Reserved
ⓧ NA	0x30000000 – 0x300003FF	8/16-bit	PC/104 I/O space
-	0x30000400 – 0x3BFFFFFFF	-	Reserved
ⓧ NA	0x3C000000 – 0x3C1FFFFFFF	8/16-bit	PC/104 memory space
-	0x3C200000 – 0x3FFFFFFF	-	Reserved
NA	0x40000000 – 0x43FFFFFFF	32-bit	PXA270 peripherals <sup>1</sup>
NA	0x44000000 – 0x47FFFFFFC	32-bit	LCD control registers <sup>1</sup>
NA	0x48000000 – 0x4BFFFFFFC	32-bit	Memory controller registers <sup>1</sup>
ⓧ NA	0x4C000000 – 0x4FFFFFFC	32-bit	USB host registers <sup>1</sup>
NA	0x50000000 – 0x53FFFFFFC	32-bit	Capture Interface registers <sup>1</sup>
-	0x54000000 – 0x57FFFFFFC	-	Reserved
NA	0x58000000 – 0x5BFFFFFFC	32-bit	Internal memory control <sup>1</sup>
NA	0x5C000000 – 0x5C00FFFC	32-bit	Internal SRAM bank 0
NA	0x5C010000 – 0x5C01FFFC	32-bit	Internal SRAM bank 1
NA	0x5C020000 – 0x5C02FFFC	32-bit	Internal SRAM bank 2
NA	0x5C030000 – 0x5C03FFFC	32-bit	Internal SRAM bank 3
-	0x5C040000 – 0X7FFFFFFF	-	Reserved
SDCS0#	0x80000000 – 0x8FFFFFFF	32-bit	SDRAM
-	0x90000000 – 0xFFFFFFFF	-	Reserved

<sup>1</sup> Details of the internal registers are in the Intel Developer's Manual on the Development Kit CD.



## Translations made by the MMU

For details of translations made by the MMU by Redboot for embedded Linux, please refer to the TITAN Embedded Linux Quickstart Manual.

For details of translations made by the MMU for Windows CE, please check the Windows CE documentation for information about memory mapping. One source of this information is on the MSDN web site ([www.msdn.microsoft.com](http://www.msdn.microsoft.com)) under Windows CE Memory Architecture.

## PXA270 processor

The TITAN board is based on a PXA270 processor, [www.intel.com/design/pca/prodbref/253820.htm](http://www.intel.com/design/pca/prodbref/253820.htm).

The PXA270 processor is an integrated system-on-a-chip microprocessor for high-performance, low-power portable handheld and handset devices. It incorporates on-the-fly voltage and frequency scaling and sophisticated power management.

The PXA270 processor complies with the ARM\* Architecture V5TE instruction set (excluding floating point instructions) and follows the ARM\* programmer's model. The PXA270 processor also supports Intel® Wireless MMX™ integer instructions in applications such as those that accelerate audio and video processing.

The features of the PXA270 processor include:

- Intel® XScale™ core.
- Power management.
- Internal memory - 256KB of on-chip RAM.
- Interrupt controller.
- Operating system timers.
- Pulse-width modulation unit (PWM).
- Real time clock (RTC).
- General purpose I/O (GPIO).
- Memory controller.
- DMA controller.
- Serial ports:
  - 3x UART.
  - Fast infrared port.
  - I<sup>2</sup>C bus port.
  - AC97 Codec interface.
  - I<sup>2</sup>S Codec interface.
  - USB host controller (2 ports).
  - USB client controller.
  - 3x synchronous serial ports (SSP).
- LCD panel controller.

- Multimedia card, SD memory card and SDIO card controller.
- Memory stick host controller.
- Mobile scalable link (MSL) interface.
- Keypad interface.
- Universal subscriber identity module (USIM) interface.
- Quick Capture camera interface.
- JTAG interface.
- 356-pin VF-BGA packaging.

The design supports 520MHz, 416MHz and 312MHz speed variants of the PXA270 processor. The standard variant of the TITAN board includes the 520MHz version of the PXA270. The TITAN-LITE board is fitted with the a 312MHz version of the PXA270. The maximum speed available for extended temperature versions of the TITAN is 416MHz.

A 13MHz external crystal is used to run the PXA270 processor. All other clocks are generated internally in the processor.

The PXA270 processor family provides multimedia performance, low power capabilities and rich peripheral integration. Designed for wireless clients, it incorporates the latest Intel advances in mobile technology over its predecessor, the PXA255 processor. The PXA270 processor features scalability by operating from 104MHz up to 520MHz, providing enough performance for the most demanding control and monitoring applications.

PXA270 is the first Intel® Personal Internet Client Architecture (PCA) processor to include Intel® Wireless MMX™ technology, enabling high performance, low power multimedia acceleration with a general purpose instruction set. Intel® Quick Capture technology provides a flexible and powerful camera interface for capturing digital images and video. Power consumption is also a critical component. Wireless Intel SpeedStep® technology provides the new capabilities in low power operation.

The processor requires a number of power supply rails. All voltage levels are generated on-board from the +5V power input. The TITAN uses a specialised power management IC to support Intel SpeedStep® technology.

The PXA270 processor is a low power device and does not require a heat sink for temperatures up to 70°C (85°C for the industrial variant).

## PXA270 GPIO pin assignments

The table below summarizes the use of the 118 PXA270 GPIO pins, their direction, alternate function and active level.



For embedded Linux the GPIO pins are setup by Redboot. For Windows CE, they are setup by the OS and not by the boot loader.

For details of pin states during reset see the Pin Usage table in the PXA27x Processor Family Electrical, Mechanical and Thermal Specification.

### Key:

AF Alternate function.













Dir Pin direction.









Active Function active level or edge.









Sleep Pin state during sleep mode:







- Hi-Z states are set to '1' during sleep.
- Last states are whatever the last state was before going to sleep.

GPIO		No	AF	Signal name	Dir	Active	Function	Sleep	Wake-up source	See section...
	0	0	AC97_IRQ	Input		AC97 interrupt	Input	✓	<a href="#">Audio</a>	
	1	0	DS_WAKEUP	Input		Deep sleep wakeup	Input	✓		
	2	0	SYS_EN	Output	High	Enable 3.3V supplies	1	-		
	3	0	PWR_SCL	Output	NA	Control PXA270 supplies	1	-		
	4	0	PWR_SDA	Bidir	NA		Input	-	<a href="#">Power and power management</a>	
	5	0	PWR_CAP0	Power	-		-	-		
	6	0	PWR_CAP1	Power	-	To achieve low power in	-	-		
	7	0	PWR_CAP2	Power	-	during sleep	-	-		
	8	0	PWR_CAP3	Power	-		-	-		
	9	0	COM1OR4_WAKEUP	Input		COM1 to COM4 activity	Input	✓		
	10	0	COM4_IRQ	Input		COM 4 interrupt	Input		<a href="#">Serial COMs ports</a>	
	11	0	COM5_IRQ	Input		COM 5 interrupt	Input	✓		
	12	0	OVERTEMP	Input		Temperature sensor over temperature IRQ	Input	✓	<a href="#">I<sup>2</sup>C</a>	
	13	0	USER_LINKA	Input		User configurable	Input	✓	<a href="#">External interrupts</a>	
	14	0	ETH_IRQ#	Input		Ethernet interrupt	Input	✓	<a href="#">Ethernet</a>	
	15	2	ETH_CS1#	Output	Low	Chip select 1	1	-		

GPIO								
No	AF	Signal name	Dir	Active	Function	Sleep	Wake-up source	See section...
16	2	PWM0	Output	See inverter datasheet	Backlight on/off or variable brightness if PWM	0	-	<a href="#">Flat panel display support</a>
	17	0	PC104_IRQ	Input		'OR' of PC/104 interrupts	Input	✓ <a href="#">PC/104 interface</a>
18	0	CLK_SHDN#	Output	Low	Shutdown clocks	0	-	-
19	0	BKLEN	Output	High	LCD backlight enable	0	-	<a href="#">Flat panel display support</a>
20	0	RS232_SHDN#	Output	Low	Shutdown COM 1, 2, 3, & 4	0	-	<a href="#">Serial COMs ports</a>
21	0	LVDS_EN	Output	High	0 = LVDS power down [default] 1 = LVDS enable	0	-	<a href="#">LVDS interface</a>
	22	0	USB_PWE2	Output	High	USB channel 2 power enable	0	- <a href="#">USB</a>
23	1	CIF_MCLK	Output	NA	Camera interface master clock	0	-	-
24	1	CIF_FV	Input	NA	Camera interface frame sync - vertical	Input	-	<a href="#">Quick Capture camera interface</a>
25	1	CIF_LV	Input	NA	Camera interface line sync - horizontal	Input	-	-
26	2	CIF_PCLK	Input	NA	Camera interface pixel clock	Input	-	-
	27	0	LVDS_FES#	Output	Low	0 = LVDS falling edge strobe 1 = LVDS rising edge strobe [default]	1	- <a href="#">LVDS interface</a>
	28	1	AC97_BITCLK	Input		AC97 BITCLK	Input	-
	29	1	AC97_DIN	Input	NA	AC97 SDATA_IN0	Input	- <a href="#">Audio</a>
	30	2	AC97_DOUT	Output	NA	AC97 SDATA_OUT	0	-
	31	2	AC97_SYNC	Output		AC97 SYNC	0	-
32	2	MMCLK	Output	NA	SDIO clock	0	-	-
	33	2	SRAM_CS5#	Output	Low	Chip select 5	1	- <a href="#">Memory</a>
34	1	RXD1	Input	NA	COM1 receive data	Input	-	<a href="#">Serial COMs ports</a>
35	0	USER_LINKB	Input		User configurable	Input	✓	<a href="#">External interrupts</a>

GPIO								
No	AF	Signal name	Dir	Active	Function	Sleep	Wake-up source	See section...
36	1	DCD1	Input	NA	COM1 data carrier detect	Input	-	
37	1	DSR1	Input	NA	COM1 data sender ready	Input	-	
38	1	RI1	Input	NA	COM1 ring indicator	Input	-	
39	2	TXD1	Output	NA	COM1 transmit data	0	-	
40	2	DTR1	Output	NA	COM1 data terminal ready	0	-	
41	2	RTS1	Output	NA	COM1 request to send	0	-	
42	1	RXD2	Input	NA	COM2 receive data	Input	-	<a href="#">Serial COMs ports</a>
43	2	TXD2	Output	NA	COM2 transmit data	0	-	
44	1	CTS2	Input	NA	COM2 clear to send	Input	-	
45	2	RTS2	Output	NA	COM2 request to send	0	-	
46	2	RXD3	Input	NA	COM3 receive data	Input	-	
47	1	TXD3	Output	NA	COM3 transmit data	0	-	
	48	2	CB_POE#	Output	Low	Socket 0 & 1 output enable	1	-
	49	2	CB_PWE#	Output	Low	Socket 0 & 1 write enable	1	-
	50	2	CB_PIOR#	Output	Low	Socket 0 & 1 I/O read	1	-
	51	2	CB_PIOW#	Output	Low	Socket 0 & 1 I/O write	1	-
	52	0	MMC_WP	Input	High	SDIO write protect status	Input	-
	53	0	MMC_CD	Input		SDIO card detect	Input	✓
	54	2	CB_PCE2#	Output	Low	Socket 0 & 1 high byte enable	1	-
	55	0	DUART_CLK8/16	Output	NA	0 = 8 x sampling; double standard baud rates 1 = 16 x sampling; standard baud rates [default]	1	- <a href="#">Serial COMs ports</a>
	56	1	CB_PWAIT#	Input	Low	PWAIT	Input	-
	57	1	CB_PIOIS16#	Input	Low	IOIS16	Input	-
	58	2	LCD_D0	Output	NA	LCD data bit 0	0	-
	59	2	LCD_D1	Output	NA	LCD data bit 1	0	-
	60	2	LCD_D2	Output	NA	LCD data bit 2	0	-
	61	2	LCD_D3	Output	NA	LCD data bit 3	0	-
	62	2	LCD_D4	Output	NA	LCD data bit 4	0	- <a href="#">Flat panel display support</a>
	63	2	LCD_D5	Output	NA	LCD data bit 5	0	-
	64	2	LCD_D6	Output	NA	LCD data bit 6	0	-
	65	2	LCD_D7	Output	NA	LCD data bit 7	0	-
	66	2	LCD_D8	Output	NA	LCD data bit 8	0	-
	67	2	LCD_D9	Output	NA	LCD data bit 9	0	- <i>continued...</i>

GPIO							Wake-up		
No	AF	Signal name	Dir	Active	Function	Sleep	source	See section...	
68	2	LCD_D10	Output	NA	LCD data bit 10	0	-		
69	2	LCD_D11	Output	NA	LCD data bit 11	0	-		
70	2	LCD_D12	Output	NA	LCD data bit 12	0	-		
71	2	LCD_D13	Output	NA	LCD data bit 13	0	-		
72	2	LCD_D14	Output	NA	LCD data bit 14	0	-		
73	2	LCD_D15	Output	NA	LCD data bit 15	0	-		
74	2	LCD_FCLK	Output	NA	LCD frame clock (STN) / vertical sync (TFT)	0	-	<a href="#">Flat panel display support</a>	
75	2	LCD_LCLK	Output	NA	LCD line clock (STN) / horizontal sync (TFT)	0	-		
76	2	LCD_PCLK	Output	NA	LCD pixel clock (STN) / clock (TFT)	0	-		
77	2	LCD_BIAS	Output	NA	LCD bias (STN) / date enable (TFT)	0	-		
	78	0	DUART_HDCNTL	Output	NA	COM4&5 0 = RS485 half duplex control 1 = Normal RTS function (default)	1	-	<a href="#">Serial COMs ports</a>
	79	1	CB_PSKTSEL	Output	NA	0 = Socket 0 select 1 = Socket 1 select	1	-	-
	80	2	CPLD_CS4#	Output	Low	Chip select 4	1	-	-
	81	0	SEL_485#	Output	NA	COM5 0 = RS485 1 = RS422 [default]	1	-	<a href="#">Serial COMs ports</a>
	82	0	BIAS_EN	Output	NA	0 = STN BIAS voltage off [default] 1 = STN BIAS voltage on	0	-	<a href="#">Flat panel display support</a>
	83	0	REDUCED_SLEW#	Output	Low	COM5 0 = reduced slew 1 = normal [default]	1	-	<a href="#">Serial COMs ports</a>
	84	0	DUART_CLKSEL	Output	NA	DUART (COM4&5) clock pre-scaler 0 = divide by 4 1 = divide by 1 [default]	1	-	<a href="#">Serial COMs ports</a>
	85	1	CB_PCE1#	Output	Low	Socket 0 & 1 low byte enable	1	-	-
	86	2	LCD_D16	Output	NA	LCD data bit 16	0	-	<a href="#">Flat panel display support</a>
	87	2	LCD_D17	Output	NA	LCD data bit 17	0	-	<a href="#">Flat panel display support</a>
	88	1	USB_OC1#	Input		USB channel 1 over current detection	Input	-	<a href="#">USB</a>
	89	2	USB_PWE1	Output	High	USB channel 1 power enable	0	-	

GPIO							Wake-up		
No	AF	Signal name	Dir	Active	Function	Sleep	source	See section...	
90	3	CIF_DD4	Input	NA	Camera interface data 4	Input	-	<a href="#">Quick Capture camera interface</a>	
91	0	RECOVER	Input		Factory SW Recovery	Input	-	-	
92	1	MMDAT0	Bidir	NA	SDIO data 0	Input	-	-	
93	2	CIF_DD6	Input	NA	Camera interface data 6	Input	-	<a href="#">Quick Capture camera interface</a>	
94	2	CIF_DD5	Input	NA	Camera interface data 5	Input	-	<a href="#">Quick Capture camera interface</a>	
	95	1	AC97_RST#	Output	Low	AC97 reset	1	-	<a href="#">Audio</a>
	96	0	WD_SET0	Output		Watchdog timeout	1	-	<a href="#">Watchdog timer</a>
	97	0	WD_SET1	Output	NA	Watchdog timeout	1		<a href="#">Watchdog timer</a>
	98	2	CIF_DD0	Input	NA	Camera interface data 0	Input	-	<a href="#">Quick Capture camera interface</a>
	99	0	WD_SET2	Output	NA	Watchdog timeout	0	-	<a href="#">Watchdog timer</a>
	100	1	CTS1	Input	NA	COM1 clear to send	Input		<a href="#">Serial COMs ports</a>
	101	0	LCDEN	Output	High	LCD logic supply enable	0	-	<a href="#">Flat panel display support</a>
	102	0	WD_WDI	Output	NA	Watchdog input	1		<a href="#">Watchdog timer</a>
	103	1	CIF_DD3	Input	NA	Camera interface data 3	Input	-	
	104	1	CIF_DD2	Input	NA	Camera interface data 2	Input	-	
	105	1	CIF_DD1	Input	NA	Camera interface data 1	Input	-	<a href="#">Quick Capture camera interface</a>
	106	1	CIF_DD9	Input	NA	Camera interface data 9	Input	-	<a href="#">Quick Capture camera interface</a>
	107	1	CIF_DD8	Input	NA	Camera interface data 8	Input	-	
	108	1	CIF_DD7	Input	NA	Camera interface data 7	Input	-	
	109	1	MMDAT1	Bidir	NA	SDIO data 1	Input	-	
	110	1	MMDAT2	Bidir	NA	SDIO data 2	Input	-	
	111	1	MMDAT3	Bidir	NA	SDIO data 3	Input	-	-
	112	1	MMCMD	Bidir	NA	SDIO command	Input	-	
	113	0	USER_LINKC	Input		User configurable	Input	✓	<a href="#">External interrupts</a>
	114	0	USB_OC2	Input		USB channel 2 over current detection	Input	-	<a href="#">USB</a>
	115	0	SEL_TERM	Output	NA	RS422/485 (COM5) 0 = No termination 1 = 120Ω termination [default]	0	-	<a href="#">Serial COMs ports</a>
	116	0	GPIO_IRQ	Input		GPIO interrupt	Input	✓	<a href="#">General purpose I/O</a>
	117	1	I <sup>2</sup> C_SCL	Output	NA	I <sup>2</sup> C clock	1	-	<a href="#">I<sup>2</sup>C</a>
	118	1	I <sup>2</sup> C_SDA	Bidir	NA	I <sup>2</sup> C data	Input	-	













## Interrupt assignments

### Internal interrupts

For details of the PXA270 interrupt controller and internal peripheral interrupts, please refer to the PXA270 Developer's Manual on the Development Kit CD.

### External interrupts

The following table lists the PXA270 signal pins used for external interrupts:

PXA270 pin	Signal name	Peripheral	Active
⊗ GPIO 0	AC97_IRQ	Audio	
GPIO 1	DS_WAKEUP	CPU	
GPIO 9	COM1OR4_WAKEUP	COMS	
⊗ GPIO 11	COM5_IRQ	COMS	
GPIO 12	OVERTEMP	Temperature sensor	
GPIO 13	USER_LINKA	User	
GPIO 14	ETH_IRQ#	Ethernet	
⊗ GPIO 17	PC104_IRQ	PC/104	
GPIO 35	USER_LINKB	User	
GPIO 53	MMC_CD	SDIO	
GPIO 113	USER_LINKC	User	
GPIO 116	GPIO_IRQ#	External GPIO	



## Real time clock

The TITAN uses an external real time clock (RTC) (Intersil ISL1208) to store the date and time and provide power management events. The RTC is connected to the I<sup>2</sup>C bus of the PXA270 processor and is accessible through I<sup>2</sup>C bus address 0x6F. The RTC is battery backed for the TITAN, but is not battery backed for the TITAN-Lite.

The accuracy of the internal RTC is based on the operation of the 32.768KHz watch crystal. Its calibration tolerance is  $\pm 20$ ppm, which provides an accuracy of +/-1 minute per month when the board is operated at an ambient temperature of +25°C (+77°F). When the board is operated outside this temperature the accuracy may be degraded by -0.035ppm/°C<sup>2</sup>  $\pm 10\%$  typical. The watch crystal's accuracy will age by  $\pm 3$ ppm max in the first year, then  $\pm 1$ ppm max in the year after, and logarithmically decreasing in subsequent years.

The Intersil ISL1208 RTC provides the following basic functions:

- Real time clock/calendar:
  - Tracks time in hours, minutes and seconds.
  - Day of the week, day, month and year.
- Single alarm:
  - Settable to the second, minute, hour, day of the week, day or month.
  - Single event or pulse interrupt mode.
- 2 bytes battery-backed user SRAM.
- I<sup>2</sup>C interface.

PXA270 has an internal real time clock, which doesn't keep time after hardware reset and should only be used as a wake-up source from deep-sleep.

## Watchdog timer

The TITAN uses an external watchdog timer (MAX6369), which can be used to protect against erroneous software.

The watchdog timer can be programmed using WD\_SET0-2 for timeout periods between 1ms and 60s. When the timeout occurs the TITAN is reset.

The watchdog timeout period is summarized in the following table:

WD_SET2 GPIO 99	WD_SET1 GPIO 97	WD_SET0 GPIO 96	Timeout period
0	0	0	1ms
0	0	1	10ms
0	1	0	30ms
0	1	1	Disabled (default)
1	0	0	100ms
1	0	1	1s
1	1	0	10s
1	1	1	60s

Once the timeout period is set the WD\_WDI (GPIO102) watchdog input signal must be toggled within the timeout period. If WD\_WDI remains either high or low for the duration of the watchdog timeout period, the watchdog timer triggers a reset pulse.

The watchdog timer clears whenever a reset pulse is asserted or whenever WDI sees a rising or falling edge.

For further details see the Eurotech operating system Technical Manual and the *PXA270 Developer's Manual* on the Development Kit CD.

## Memory

The TITAN has four types of memory fitted:

- A 16MB (TITAN-LITE only), 32MB or 64MB resident FLASH disk containing:
  - Boot loader: Redboot to boot embedded Linux, or Eboot to boot Windows CE.
  - Embedded Linux or Windows CE.
  - Application images.
- 64MB or 128MB (64MB for TITAN-LITE) of SDRAM for system memory.
- Static RAM:
  - 256KB of SRAM internal to PXA270.
  - 256KB of SRAM external to PXA270 (battery backed).
- 128 bytes of configuration EEPROM on the I<sup>2</sup>C bus.

### FLASH memory / silicon disk

The TITAN supports 16MB (TITAN-LITE only), 32MB or 64MB of AMD Mirrorbit Flash memory for the boot loader, OS and application images. The Flash memory is arranged as 64Mbit x 16-bits (16MB device), 128Mbit x 16-bits (32MB device) or 256Mbit x 16-bits (64MB device) respectively.

The FLASH memory array is divided into equally sized symmetrical blocks that are 64-Kword in size (128KB) sectors. A 128Mbit device contains 128 blocks, a 256Mbit device contains 256 blocks and a 512Mbit device contains 512 blocks.

Whenever the FLASH memory is accessed the FLASH access LED is illuminated.

### SDRAM interface

There are two standard memory configurations supported by the TITAN: 64MB or 128MB of SDRAM located in bank 0. The 128MB option is not available for the standard TITAN-Lite variants. The SDRAM is configured as 16MB x 32-bits (64MB), or 32MB x 32-bits (128MB) by 2 devices, each with 4 internal banks of 4MB or 8MB x 16-bits.

These are surface mount devices soldered to the board and cannot be upgraded. The size of memory fitted to the board is detected by software to configure the SDRAM controller accordingly.

The SDRAM memory controller is set to run at 104MHz.

## Static RAM



The PXA270 processor provides 256KB of internal memory-mapped SRAM. The SRAM is divided into four banks, each consisting of 64KB.

The TITAN also has a 256KB SRAM device fitted, arranged as 256Kbit x 8-bits. Access to the device is on 16-bit boundaries; whereby the least significant byte is the SRAM data and the 8-bits of the most significant byte are don't care bits. The reason for this is that the PXA270 is not designed to interface to 8-bit peripherals. This arrangement is summarized in the following data bus table:

Most significant byte								Least significant byte							
D15	D14	D13	D12	D11	D10	D9	D8	D7	D6	D5	D4	D3	D2	D1	D0
Don't care								SRAM data							

The SRAM is non-volatile whilst the on-board battery is fitted.

## Configuration EEPROM

The configuration EEPROM is interfaced directly to the PXA270's I<sup>2</sup>C controller. It is a Microchip 24AA01 1Kbit EEPROM organized as one block of 128 x 8-bit memory.

The configuration EEPROM is addressable at I<sup>2</sup>C serial bus address 0x50 – 0x057 and is accessed in fast-mode operation at 400kbps.

## SDIO

The SD card socket J7 is interfaced directly to the PXA270's MMC/SD/SDIO controller.

The MMC/SD/SDIO controller supports multimedia card, secure digital and secure digital I/O communications protocols. The MMC controller supports the MMC system, a low-cost data storage and communications system. The MMC controller in the PXA270 processor is based on the standards outlined in the *MultiMediaCard System Specification Version 3.2*. The SD controller supports one SD or SDIO card based on the standards outlined in the *SD Memory Card Specification Version 1.01 and SDIO Card Specification Version 1.0 (Draft 4)*.

The MMC/SD/SDIO controller features:

- Data transfer rates up to 19.5Mbps for MMC, 1-bit SD/SDIO and SPI mode data transfers.
- Data transfer rates up to 78Mbps for 4-bit SD/SDIO data transfers.
- Support for all valid MMC and SD/SDIO protocol data-transfer modes.

This is a hot swappable 3.3V interface, controlled by the detection of a falling edge on GPIO 53 (MMC\_CD) when an SD card has been inserted, and a rising edge when an SD card is removed.

SD card write protection is connected to the PXA270's GPIO 52 (MMC\_WP), and card detect to GPIO 53 (MMC\_CD).

A variety of SDIO cards are available, such as a Camera, Bluetooth<sup>®</sup>, GPS and 802.11b. More information can be found here: [www.sdcard.org/sdio/index.html](http://www.sdcard.org/sdio/index.html).

## PC/104 interface



The TITAN PC/104 interface is emulated from the PXA270 PC card interface to support 8/16-bit ISA bus style signals. As the interface is an emulation, the TITAN does not support some PC/104 features. Please refer to the section [Unsupported PC/104 interface features](#) on page [36](#) for specific details.

Add-on boards can be stacked via the PC/104 interface to enhance the functionality of the TITAN. Eurotech has an extensive range of PC/104 compliant modules and these can be used to quickly add digital I/O, analogue I/O, serial ports, video capture devices, PC card interfaces, etc.

The ISA bus is based on the x86 architecture and is not normally associated with RISC processors. You would need to modify the standard drivers to support any third party PC/104 modules.

Any PC/104 add-on board attached to the TITAN is accessible from the PC card memory space socket 1. The memory map is shown in the following table:

Address	Region size	Region name
0x30000000 – 0x300003FF	1KB	PC/104 I/O space, 8/16-bit
0x30000400 – 0x3BFFFFFF	-	Reserved
0x3C000000 – 0x3C1FFFFFF	16MB	PC/104 memory space, 16-bit (or 8-bit write only)
0x3C200000 – 0x3FFFFFFF	-	Reserved

### PC/104 interface details

The PC/104 bus signals are compatible with the ISA bus electrical timing definitions.

All signals between the PXA270 and the PC/104 are buffered. When the PC/104 bus is not in use, all output signals with the exception of the clock signals are set to their inactive state.

The TITAN provides +5V (VCC\_PER) to the PC/104 connectors J13 and J14. If a PC/104 add-on board requires a +12V supply, then +12V can be supplied via the TITAN power connector J15 pin 4. If -12V or -5V are required, these must be supplied directly to the PC/104 add-on board.



Do NOT attempt to power the TITAN using the VCC\_PER pins!  
VCC\_PER is an isolated +5V supply switched under hardware control from the VCC input on J15 pin 1. ALWAYS provide +5V to VCC on J15 pin 1.

If J15 pin 4 is used to supply +12V to the PC/104 connector J13 pin B4. Do NOT exceed 700mA supply current at 70°C ambient, or 600mA at 85°C ambient.

PC/104 8-bit I/O read access cycle

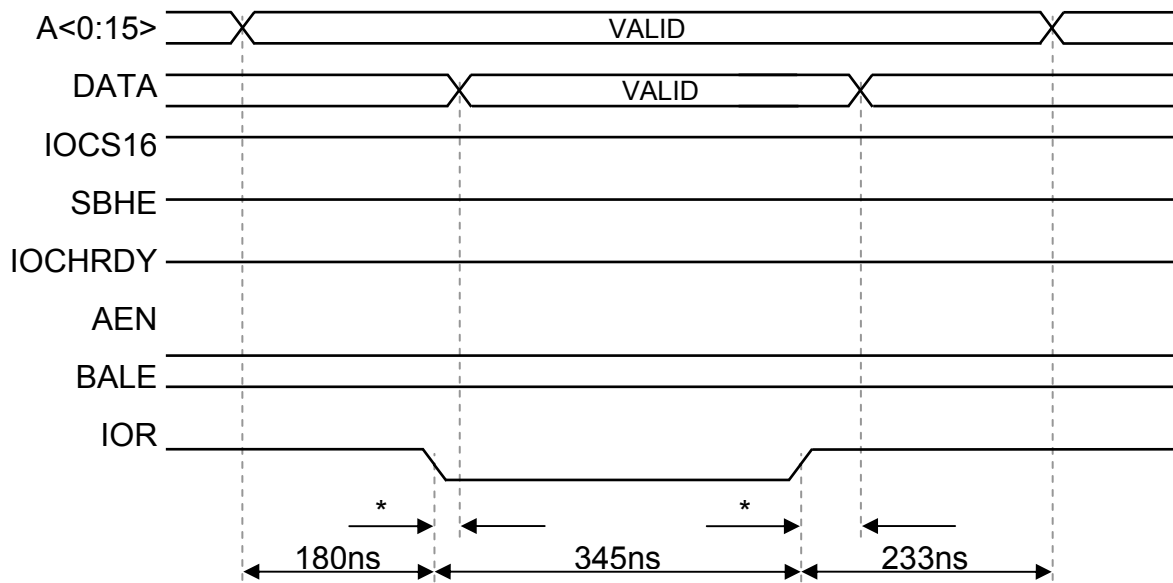

PC/104 8-bit I/O write access cycles

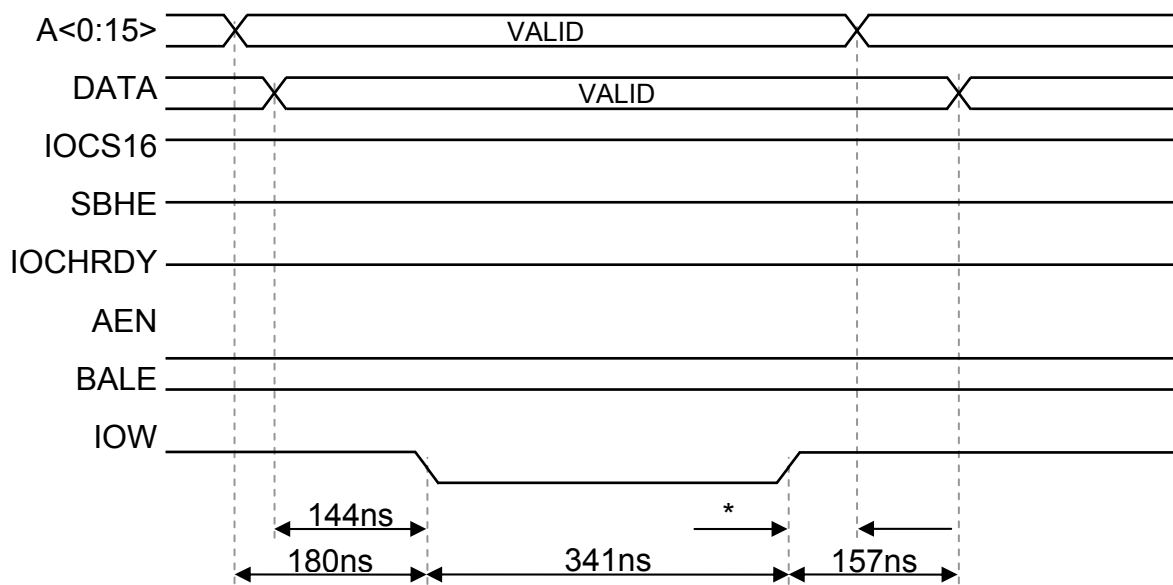

\* = PC/104 add-on-board dependant

PC/104 16-bit I/O read access cycle

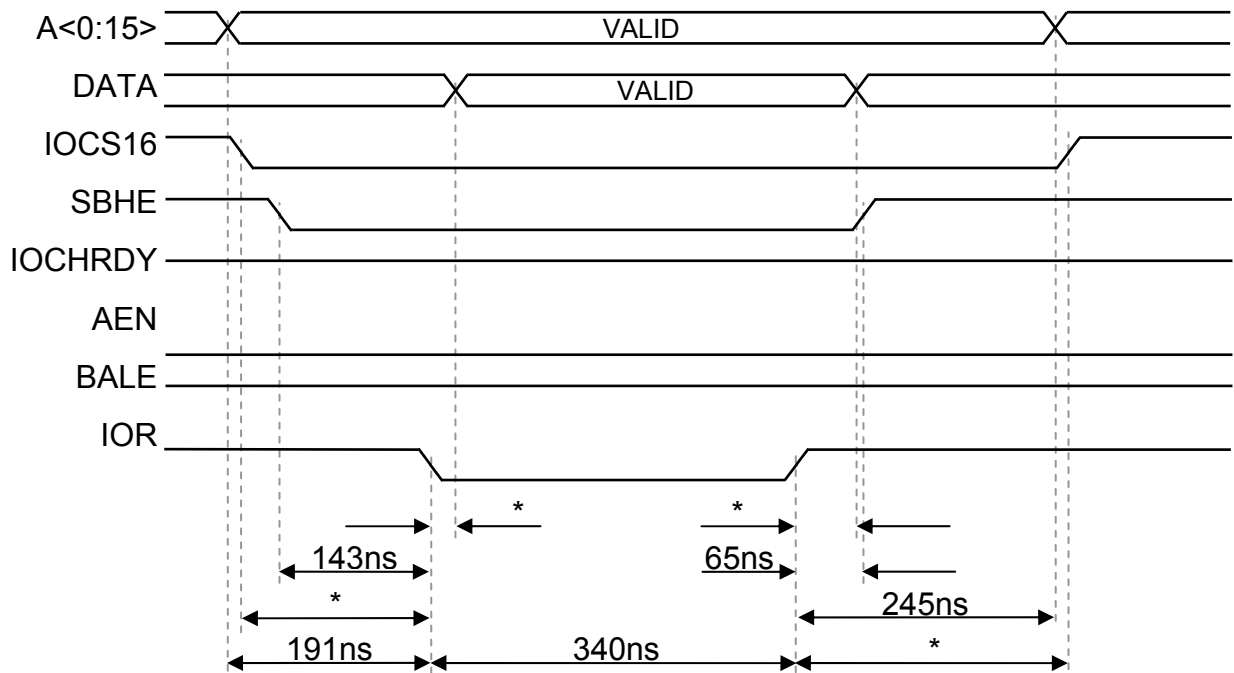

PC/104 16-bit I/O write access cycles

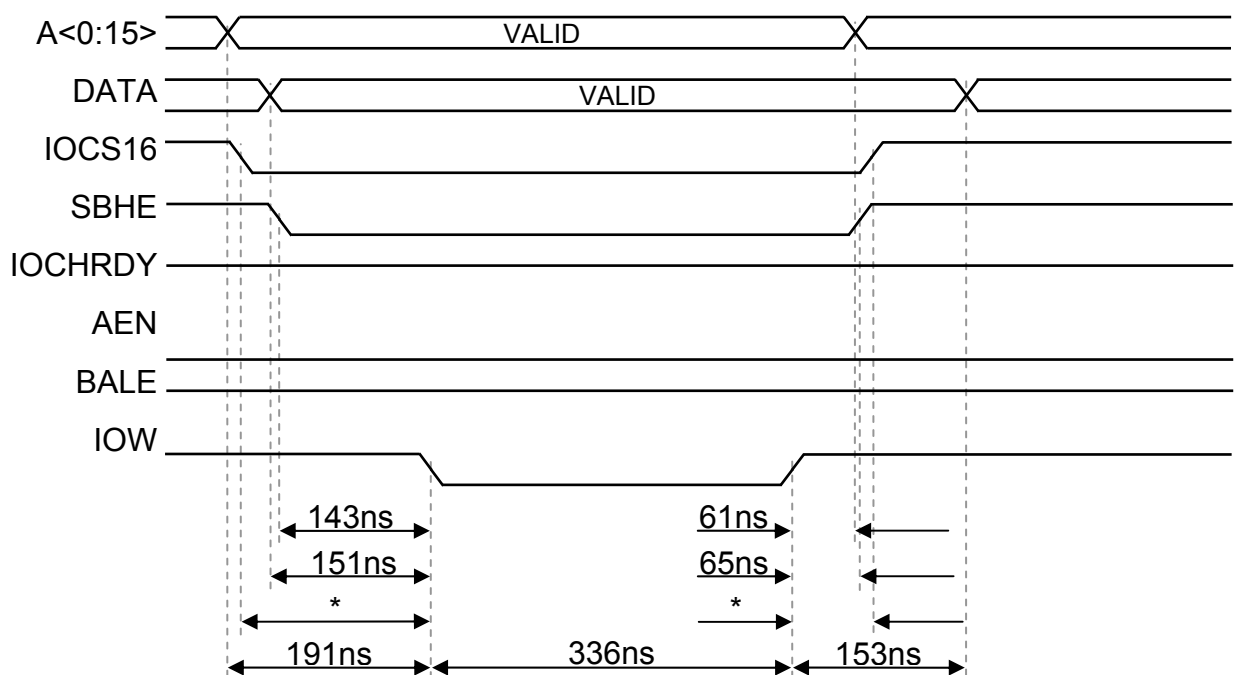

\* = PC/104 add-on-board dependant

*PC/104 8-bit memory read access cycle*

8-bit memory read access cycles are not supported by the PXA270 PCMCIA controller for common memory space.

*PC/104 8-bit memory write access cycle*

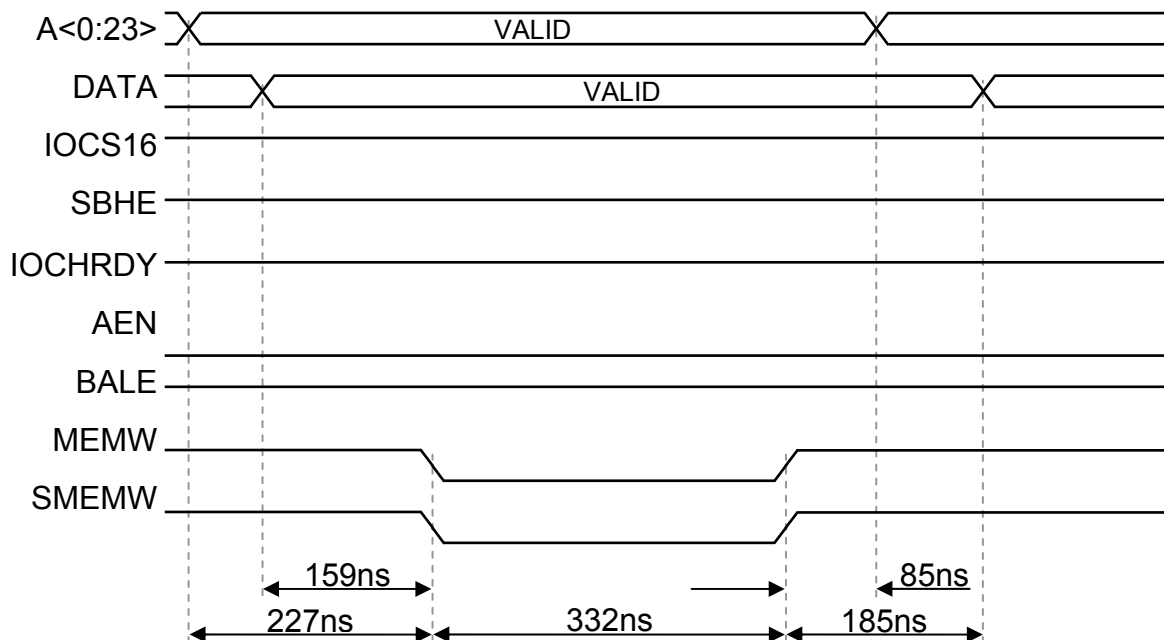

*PC/104 16-bit memory read access cycle*

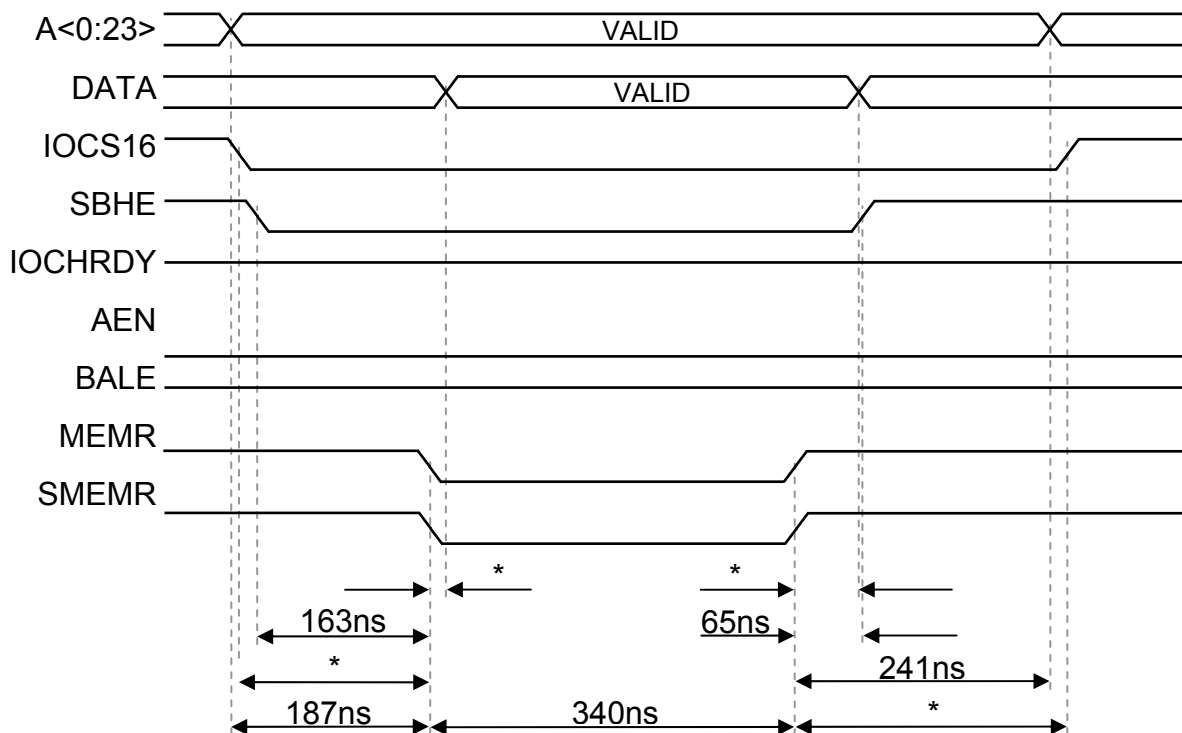



PC/104 16-bit memory write access cycles

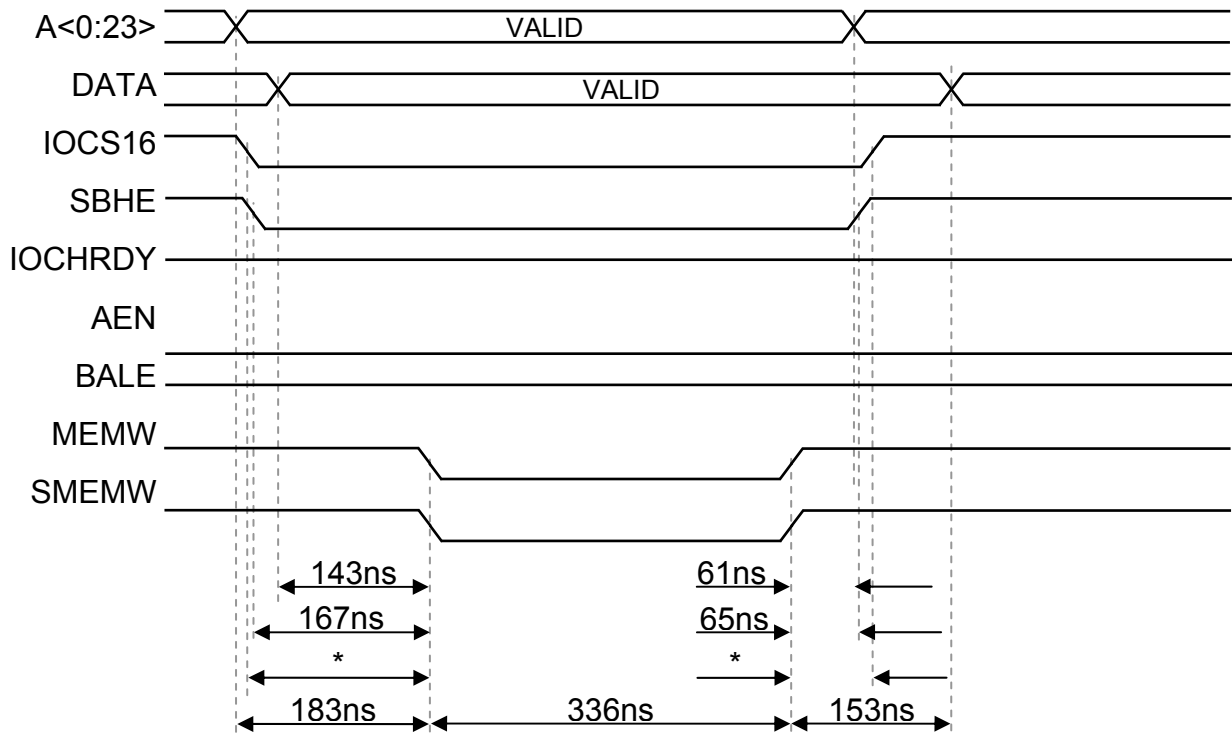

\* = PC/104 add-on-board dependant

### PC/104 interrupts



The PC/104 interrupts are combined together in the TITAN hardware. When an interrupt is received on the PC/104 interface, the hardware generates an interrupt on pin GPIO 17 (active high) of the PXA270 processor.

The PC/104 interrupting source can be identified by reading the PC104\_IRQ registers I1\_REG and I2\_REG located at addresses 0x12800000 and 0x01800000 respectively. The registers indicate the status of the interrupt lines at the time the register is read. The relevant interrupt has its corresponding bit set to '1'. The PXA270 is not designed to interface to 8-bit peripherals, so only the least significant byte from the word contains the data.

#### PC/104 interrupt register 1 [I1\_REG]

Byte lane	Most significant byte								Least significant byte							
Bit	15	14	13	12	11	10	9	8	7	6	5	4	3	2	1	0
Field	-	-	-	-	-	-	-	-	IRQ12	IRQ11	IRQ10	IRQ7	IRQ6	IRQ5	IRQ4	IRQ3
Reset	X	X	X	X	X	X	X	X	0	0	0	0	0	0	0	0
R/W	-	-	-	-	-	-	-	-	R/W							
Address	0x12800000															

#### PC/104 interrupt register 2 [I2\_REG] (not available under Windows CE)

Byte lane	Most significant byte								Least significant byte							
Bit	15	14	13	12	11	10	9	8	7	6	5	4	3	2	1	0
Field	-	-	-	-	-	-	-	-	-	-	-	-	-	IRQ15	IRQ14	IRQ9
Reset	X	X	X	X	X	X	X	X	0	0	0	0	0	0	0	0
R/W	-	-	-	-	-	-	-	-	R				R/W			
Address	0x11800000															



PC/104 IRQ9, IRQ14 and IRQ15 are not available under Windows CE as all interrupt sources are fully utilised.

Once the PXA270 microprocessor has serviced a PC/104 interrupt, the corresponding add-on-board clears the interrupt by driving the IRQ signal low. When the TITAN hardware sees the interrupt go low the corresponding bit is automatically cleared from the I1\_REG or I2\_REG register.

If no further interrupts are pending the TITAN hardware drives GPIO 17 low once the interrupt has been cleared at the source.

In cases where other PC/104 IRQs are asserted while the driver is processing a PC/104 IRQ, the TITAN drives GPIO 17 low for 375ns to 500ns once this interrupt has been cleared. This short low pulse indicates to the PXA270 that there is another pending interrupt. This situation is shown in the following diagram:

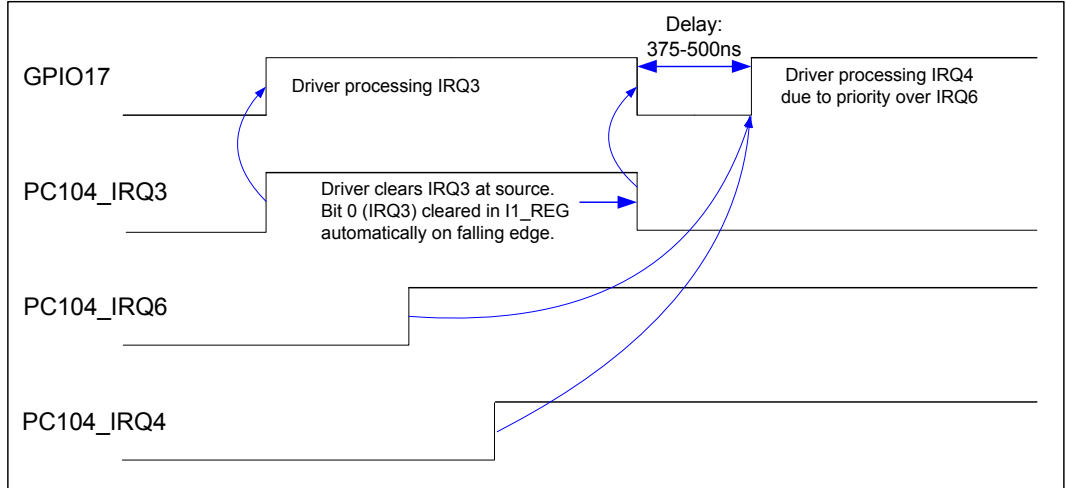

### PC/104 reset



The reset generated to the PC/104 add-on board is a combination of the nRESET\_OUT# pin of the PXA270 and the status of the PC104\_RST bit of the control register C\_REG.

To reset PC/104 add-on boards independently from the global TITAN board reset, set the PC104\_RST bit to '1' in the C\_REG register located at the address 0x13000000. To clear the PC/104 reset, write a '0' to the PC104\_RST bit.

#### PC/104 reset register [C\_REG]

Byte lane	Most significant byte								Least significant byte							
Bit	15	14	13	12	11	10	9	8	7	6	5	4	3	2	1	0
Field	-	-	-	-	-	-	-	-	-	-	-	-	-	-	-	PC104_RST
Reset	X	X	X	X	X	X	X	X	X	X	X	X	X	X	X	0
R/W	-	-	-	-	-	-	-	-	-	-	-	-	-	-	-	R/W
Address	0x13000000															

## Unsupported PC/104 interface features

The TITAN does not support the following PC/104 bus features:

- DMA is not supported. Therefore, AEN signal is set to a constant logical zero.
- Bus mastering is not supported. Therefore, do not connect any other master add-on board to the TITAN PC/104 interface.
- Shared interrupts are not supported. Therefore, do not connect more than one add-on board to the same interrupt signal line.
- BALE signal is set to a constant logical one as the address is valid over the entire bus cycle. Only add-on PC/104 boards that implement transparent latch on address lines LA17-LA23 are compatible with the TITAN implementation of BALE.
- The PXA270 PCMCIA memory controller does not support 8-bit memory read accesses for common memory space.
- The PXA270 PCMCIA memory controller does not support PC/104 MEMCS# signal, so there is no support for dynamic bus sizing.
- PC/104 IRQ9, IRQ14 and IRQ15 are not available under Windows CE.

## Flat panel display support

The PXA270 processor contains an integrated LCD display controller. It is capable of supporting both colour and monochrome single- and dual-scan display modules. It supports active (TFT) and passive (STN) LCD displays up to 800x600 pixels.

The PXA270 can drive displays with a resolution up to 800x600, but as the PXA270 has a unified memory structure, the bandwidth to the application decreases significantly. If the application makes significant use of memory, such as when video is on screen, you may also experience FIFO under-runs causing the frame rates to drop or display image disruption. Reducing the frame rate to the slowest speed possible gives the maximum bandwidth to the application. The display quality for an 800x600 resolution LCD is dependant on the compromises that can be made between the LCD refresh rate and the application. The PXA270 is **optimized** for a 640x480 display resolution.

A full explanation of the graphics controller operation can be found in the *Intel PXA27x Processor Family Developer's Manual* included on the support CD.

The flat panel data and control signals are routed to J4. See the section [J4 – LCD connector](#), page [68](#), for pin assignment and part number details.

The [ZEUS-FPIF](#) interface board allows the user to easily wire up a panel using pin and crimp style connectors (see page [88](#)). Contact Eurotech (see [Eurotech Group Worldwide Presence](#), page [101](#)) for purchasing information for the ZEUS-FPIF. Alternatively, the display interface is connected to an LVDS interface (see the section [LVDS interface](#), page [41](#)). The LVDS interface provides useful when displays need to be located more than 300mm (12") from the TITAN.

The following tables provide a cross-reference between the flat panel data signals and their function, when configured for different displays.

## TFT panel data bit mapping to the TITAN



The PXA270 can directly interface to 18-bit displays, but from a performance point of view it is better to use 16-bits only. 18-bit operation requires twice the bandwidth of 16-bit operation.

The following table shows TFT panel data bit mapping to the TITAN:

Panel data bus bit	18-bit TFT	12-bit TFT	9-bit TFT
FPD 15	R5	R3	R2
FPD 14	R4	R2	R1
FPD 13	R3	R1	R0
FPD 12	R2	R0	-
FPD 11	R1	-	-
GND	R0	-	-
FPD 10	G5	G3	G2
FPD 9	G4	G2	G1
FPD 8	G3	G1	G0
FPD 7	G2	G0	-
FPD 6	G1	-	-
FPD 5	G0	-	-
FPD 4	B5	B3	B2
FPD 3	B4	B2	B1
FPD 2	B3	B1	B0
FPD 1	B2	B0	-
FPD 0	B1	-	-
GND	B0	-	-

## STN panel data bit mapping to the TITAN

Panel data bus bit	Dual scan colour STN	Single scan colour STN	Dual scan mono STN
FPD 15	DL7(G)	-	-
FPD 14	DL6(R)	-	-
FPD 13	DL5(B)	-	-
FPD 12	DL4(G)	-	-
FPD 11	DL3(R)	-	-
FPD 10	DL2(B)	-	-
FPD 9	DL1(G)	-	-
FPD 8	DL0(R)	-	-
FPD 7	DU7(G)	D7(G)	DL3
FPD 6	DU6(R)	D6(R)	DL2
FPD 5	DU5(B)	D5(B)	DL1
FPD 4	DU4(G)	D4(G)	DL0
FPD 3	DU3(R)	D3(R)	DU3
FPD 2	DU2(B)	D2(B)	DU2
FPD 1	DU1(G)	D1(G)	DU1
FPD 0	DU0(R)	D0(R)	DU0

The table below explains the clock signals required for passive and active type displays:

TITAN	Active display signal (TFT)	Passive display signal (STN)
PCLK	Clock	Pixel clock
LCLK	Horizontal sync	Line clock
FCLK	Vertical sync	Frame clock
BIAS	DE (Data Enable)	Bias

## LCD logic and backlight power

The display signals are +3.3V compatible. The TITAN contains power control circuitry for the flat panel logic supply and backlight supply. The flat panel logic is supplied with a switched +3.3V (default) or +5V supply (see the section [LCD supply voltage jumper – LK2 on JP2](#), page 79, for details). The backlight is supplied with a switched +5V supply for the inverter.



There is no on-board protection for these switched supplies! Care must be taken during power up/down to ensure the panel is not damaged due to the input signals being incorrectly configured.

The PXA270 GPIO 101 pin controls the supply voltage for the LCD display.

LCDEN (GPIO 101)	Selected LCD function
0	LCDSAFE power off (default)
1	LCDSAFE 3.3V/5V power on



The LCD supply may be changed to 5V by moving the jumper position of JP2, see section [LCD supply voltage jumper – LK2 on JP2](#), page 79, for details. If the flat panel logic is powered from 5V, it must be compatible with 3.3V signalling, please check the LCD panel datasheet for details.

The PXA270 GPIO 19 pin (BKLEN signal) controls the supply voltage for the backlight inverter.

BKLEN (GPIO 19)	Selected backlight function
0	BKLSAFE power off (default)
1	BKLSAFE 5V power on

The BLKEN signal is routed (un-buffered) to connector J4. See the section [J4 – LCD connector](#), page 68, for J4 pin assignment and connector details.



If you want to use a 12V backlight inverter, then the switched 5V supply on BKLSAFE or the control signal BLKEN can be used to control an external 12V supply to the inverter.

Typically the following power up sequence is as follows (please check the datasheet for the particular panel in use):

- 1 Enable display VCC.
- 2 Enable flat panel interface.
- 3 Enable backlight.

Power down is in reverse order.

## LCD backlight brightness control

GPIO 16 of the PXA270 processor is used for backlight brightness control (signal PWM0 on J4 connector). The control of the backlight brightness is dependant upon the type of backlight inverter used in the display. Some inverters have a 'DIM' function, which uses a logic level to choose between two levels of intensity. If this is the case then GPIO 16 (alternative function 0) is used to set this. Other inverters have an input suitable for a pulse-width modulated signal or analogue voltage control. In this case GPIO 16 should be configured as PWM0 (alternative function 2).

When a PWM signal is required the PWM0 signal must be passed through a low pass filter. The [ZEUS-FPIF](#) board provides a low pass filter for this function (see page [88](#)). Contact Eurotech (see [Eurotech Group Worldwide Presence](#), page [101](#)) for purchasing information for the ZEUS-FPIF.

## STN BIAS voltage

The TITAN can provide a negative and a positive bias voltage for STN type displays. The negative and positive bias voltages are set to -22V and +22V respectively. Pin connections for these can be found in section [J4 – LCD connector](#), page [68](#).

BIAS_EN (GPIO 82)	Selected backlight function
0	NEGBIAS & POSBIAS power off (default)
1	NEGBIAS & POSBIAS power on

Please contact Eurotech for details of other bias voltages. Contact details are provided in [Eurotech Group Worldwide Presence](#), page [101](#).



Do not exceed a 20mA load current.



## LVDS interface



There is an optional Low-Voltage Differential Signalling (LVDS) interface available on the TITAN. LVDS combines high data rates with low power consumption. The benefits of LVDS include low-voltage power supply compatibility, low noise generation, high noise rejection and robust transmission signals.

The National Semiconductor transmitter DS90C363 is used to convert 16 bits of LCD data signals into three LVDS data streams. A phase-locked transmit clock is transmitted in parallel with the data streams over a fourth LVDS link. The LVDS signals are routed to the connector J8. For connector details see the section [J8 – LVDS connector](#), page [71](#).

The LVDS transmitter is enabled using the signal LVDS\_EN (GPIO 21). Details are shown in the following table:

LVDS_EN (GPIO 21)	Selected LVDS function
0	LVDS power down (default)
1	LVDS enable

The LVDS transmitter can be programmed for rising edge strobe or falling edge strobe operation through a signal LVDS\_FES# (GPIO 27). This is shown below:

LVDS_FES# (GPIO 27)	Selected LVDS function
0	Falling edge strobe
1	Rising edge strobe (default)

If the FPIF-LVDS-TX is to be connected directly to an LVDS display via the Hirose connector J2, then this link selects the displays LVDS Receiver input map. Fitting or not fitting a jumper to JP3 sets J2 pin 20 (MSL) to 3.3V or GND (default) respectively.

When the LVDS interface is used, connector LK3 on JP3 should be set to the correct setting for the display. See section [LVDS mode select \[MSL\] jumper – LK3 on JP3](#), page [79](#), for details. Please consult the manual of your LVDS display for which setting to use for the National Semiconductor DS90C383 LVDS Transceiver.

Connector J4 should be used to supply the power and brightness control for the backlight inverter when the LVDS interface is used. See the section [J4 – LCD connector](#), page [68](#), for J4 pin assignment and connector details.

## Audio



The Wolfson WM9712L AC'97 audio CODEC is used to support the audio features of the TITAN. Audio inputs supported by the WM9712L are a stereo line in and a mono microphone input.

The WM9712L provides a stereo line out that can also be amplified by the National Semiconductor LM4880 250mW per channel power amplifier. This amplifier is suitable for driving an 8Ω load.

The WM9712L AC'97 CODEC may be turned off if it is not required. See the section [Audio power management](#), page [62](#), for details.

Connection to the TITAN audio features is via header J6. See the table below for pin assignments and section [J6 – Audio connector](#), page [69](#), for connector and mating connector details.

Function	Pin	Signal	Signal levels (max)	Frequency response (Hz)
Microphone	10	MIC input		
	9	MIC voltage reference output	1Vrms	20 – 20k
	7	Audio ground reference		
Line in	1	Line input left		
	5	Line input right	1Vrms	20 – 20k
	3	Audio ground reference		
Line out	2	Line output left		
	6	Line output right	1Vrms	20 – 20k
	4	Audio ground reference		
Amp out	8	Amp output left	1.79V peak, 1.26Vrms (8Ω load) 223mW	20 – 20k
	11	Amp output right		
	12	Audio ground reference		

## Touchscreen controller



The TITAN supports 4-wire and 5-wire resistive touchscreens using the touchscreen controller available on the Wolfson WM9712L audio CODEC. The touchscreen controller supports the following functions:

- X co-ordinate measurement.
- Y co-ordinate measurement.
- Pen down detection with programmable sensitivity.
- Touch pressure measurement (4-wire touchscreen only).

A touchscreen can be used as a wake-up source for PXA270 from sleep mode.

The touchscreen interface is broken out on the header J5. See [J5 – Touchscreen connector](#), page [69](#), for connector and mating connector details.

## USB

### USB host



There are two USB host interfaces on the TITAN. These comply with the Universal Serial Bus Specification Rev. 1.1, supporting data transfer at full-speed (12Mbps) and low-speed (1.5Mbps).

There are four signal lines associated with each USB channel: VBUS, DATA+, DATA and GND. Their arrangement is summarized in the illustration below:

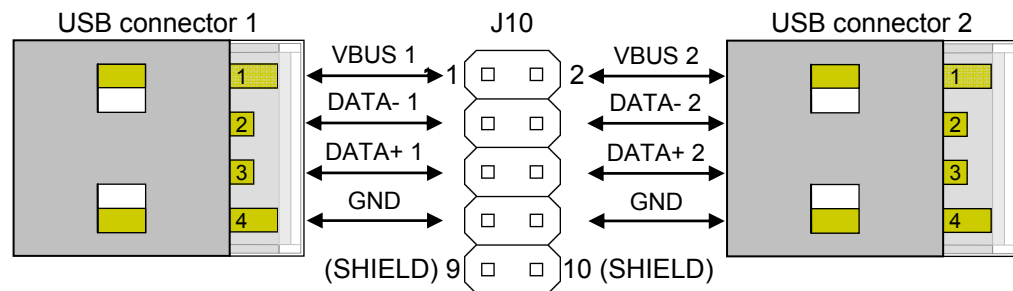

A USB power control switch controls the power and protects against short-circuit conditions.

If the USB voltage is short-circuited, or more than 500mA is drawn from either supply, the switch turns the power supply off and automatically protects the device and board. If an over current condition occurs on a USB channel, the over current condition is flagged to GPIO 88 and GPIO 114 for USB channel 1 and channel 2 respectively. This is shown in the following tables:

USB_OC1 (GPIO 889)	Selected LVDS function
0	USB VBUS1 over current
1	USB VBUS1 normal

USB_OC2 (GPIO 114)	Selected LVDS function
0	USB VBUS2 over current
1	USB VBUS2 normal

The VBUS power supplies are derived from VCC\_PER (+5V) which is an isolated +5V supply switched under hardware control from the VCC input on J15 pin 1. GPIO 89 and GPIO 22 control the power to VBUS1 and VBUS2 respectively. This is shown in the following tables:

USB_PWE1 (GPIO 89)	Selected LVDS function
0	USB VBUS1 power off (default)
1	USB VBUS1 power on

USB_PWE2 (GPIO 22)	Selected LVDS function
0	USB VBUS2 power off (default)
1	USB VBUS2 power on

More information about the USB bus and the availability of particular USB peripherals can be found at [www.usb.org](http://www.usb.org).

### USB client

The TITAN USB host port 2 can be configured under software to be a client.

The following diagram shows the connection between PL17 and a USB type A connector:

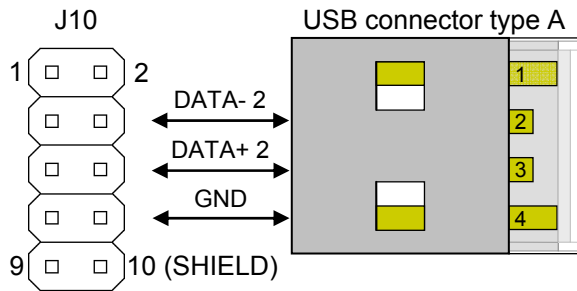

Do NOT attempt to power the TITAN using the VBUS 1 or VBUS 2 pins! VBUS 1 and VBUS 2 are isolated +5V supplies switched under hardware control from VCC\_PER.



ALWAYS use the USB client cable provided with the development kit. This cable does not provide power down the cable and avoids reverse powering the TITAN from a USB host when the TITAN has no power on the VCC input on J15 pin 1. Reverse powering the TITAN from the VBUSn pins can make the TITAN operate erratically and may cause serious damage to the TITAN.

## Ethernet

The TITAN SBC provides a single 10/100-BaseTX interface with MAC and complies with both the IEEE802.3u 10/100-BaseTX and the IEEE 802.3x full-duplex flow control specifications.

A single Davicom DM9000A Ethernet controller is used to implement the Ethernet interface on the TITAN. The DM9000A device provides an embedded PHY and MAC and connects to the 10/100-BaseTX magnetics. The DM9000A also supports the AUTO-MDIX feature. Configuration data and MAC information are stored in an external serial EEPROM (93LC46).

The DM9000A device is connected to the PXA270 data bus (16-bit), and its memory is mapped. Connection to the TITAN Ethernet port is via header J11. See [J11 – 10/100BaseTX Ethernet connector](#), page 72, for pin assignment and connector details.

A second header J12 provides the speed and link status LED signals. See [J12 – Ethernet status LEDs connector](#), page 73, for pin assignment and connector details. The output lines sink current when switched on, therefore the anode of each LED should be connected to pins 1 and 3 of J12 and the cathode to the appropriate status line.



The link LED illuminates when a 10 or 100base-T link is made, and the speed LED illuminates when 100Mbps speed is selected.

The [Ethernet Breakout](#) interface board provides the user with an RJ45 connector with LEDs to connect an Ethernet cable to the TITAN (see page 96). Contact Eurotech (see [Eurotech Group Worldwide Presence](#), page 101) for purchasing information for the Ethernet Breakout.

## Serial COMs ports

There are five high-speed, fully functionally compatible 16550 serial UARTs on the TITAN. Four of these channels can be used as RS232 serial interfaces, and the remaining one, COM5, can be configured as RS422 or RS485.

Connection to the TITAN COMs ports is via header J1. See section [J1 – COMS ports](#), page [66](#), for connector and mating connector details.

Port	Address	IRQ	FIFO depth RX / TX	Signals
COM1	0x40100000 – 0x4010002C	Internal	64 / 64	RS232 Rx, Tx, CTS, RTS, RI, DSR, DCD, DTR
COM2	0x40200000 – 0x4020002C	Internal	64 / 64	RS232 Rx, Tx, RTS, CTS
COM3	0x40700000 – 0x4070002C	Internal	64 / 64	RS232 Rx, Tx
 COM4	0x10000010 – 0x1000001E	GPIO 10	128 / 128	RS232 Rx, Tx, CTS, RTS, RI, DSR, DCD, DTR
 COM5	0x10000000 – 0x1000000E	GPIO 11	128 / 128	RS422 / RS485 Tx, Rx



Please see the Developer's Manual for details of internal interrupts.

### COM1 – RS232 interface

Uses the Full Function UART in the PXA270 (FFUART). The port is buffered to RS232 levels with  $\pm 15\text{kV}$  ESD protection, and supports full handshaking and modem control signals. The maximum baud rate on this channel is 921.6kbps.

A factory fit option configures COM1 as TTL Level signals to interface to a modem. Please contact Eurotech for details. Contact details are provided in [Eurotech Group Worldwide Presence](#), page [101](#).

### COM2 – RS232 interface

Uses the Bluetooth UART in the PXA270 (BTUART). The port is buffered to RS232 levels with  $\pm 15\text{kV}$  ESD protection, and supports full handshaking and modem control signals. The maximum baud rate on this channel is 921.6kbps.

### COM3 – RS232 interface

Uses the Standard UART in the PXA270 (STUART). The port is buffered to RS232 levels with  $\pm 15\text{kV}$  ESD protection, and supports full handshaking and modem control signals. The maximum baud rate on this channel is 921.6kbps.

### COM4 – RS232 interface



The COM4 RS232 interface is supported on channel 0 of an Exar XR16C2850 with 128 bytes of Tx and Rx FIFOs, and buffered to RS232 levels with  $\pm 15\text{kV}$  ESD protection. The maximum baud rate on this channel is 921.6kbps.

### COM5 – RS422/485 interface



The COM5 RS422/485 interface is supported on channel 1 of an Exar XR16C2850 with 128 bytes of Tx and Rx FIFOs, and buffered to RS422/485 levels with  $\pm 15\text{kV}$  ESD protection. The maximum baud rate on this channel is 921.6kbps.

Two GPIOs from the PXA270 provide RS422/RS485 selection and termination resistor selection options. The two control signals are SEL\_485# on GPIO 81 and SEL\_TERM on GPIO 115. This is shown in the following table:

SEL_485# (GPIO 81)	Selected COM5 function
0	RS485 half duplex
1	RS422 full duplex [default]



SEL\_RS485# is at logic '1' upon reset.

The control signal SEL\_TERM is used to enable/disable the RS422/485 line termination and must be enabled if the TITAN board is at the end of the network. This is shown in the following table:

SEL_TERM (GPIO 115)	COM5 termination resistors (120 $\Omega$ )
0	Disconnected
1	Connected [default]



SEL\_TERM is at logic '1' upon reset.

The RS485/422 driver (LTC2859) on the TITAN features a logic-selectable reduced slew mode, which softens the driver output edges to control the high frequency EMI emissions from equipment and data cables. The reduced slew rate mode is entered by taking the SLO# pin low, where the data rate is limited to about 250kbps. Slew limiting also mitigates the adverse effects of imperfect transmission line termination caused by stubs or mismatched cables. The following table illustrates the selectable slew rates:

REDUCED_SLEW# (GPIO 83)	Slew rate
0	Reduced
1	Normal

## RS422

The RS422 interface provides full-duplex communication. The signals available are TXA, TXB, RXA, RXB and Ground. The maximum cable length for an RS422 system is 4000ft (1200m) and supports 1 transmitter and up to 10 receivers.

## RS485

This is a half-duplex interface that provides combined TX and RX signals. On J1, pin 5 provides TXB/RXB and pin 6 provides TXA/RXA. A ground connection is also required for this interface. The maximum cable length for this interface is the same as for RS422 (4000ft), but RS485 supports up to 32 transmitters and receivers on a single network. Only one transmitter should be switched on at a time.

The TITAN uses the RTS signal to control transmission. When this signal is at logic '1' the driver is switched off and data can be received from other devices. When the RTS line is at logic '0' the driver is on. Any data that is transmitted from the TITAN is automatically echoed back to the receiver. This enables the serial communications software to detect that all data has been sent, and disable the transmitter when required. The UART used on the TITAN for COM5 has extended features including auto-RTS control for RS485. This forces the RTS signal to change state (and therefore the direction of the RS485 transceivers) when the last bit of a character has been sent onto the wire. Please refer to the XR16C2850 datasheet on the Development Kit CD for more information.



The RS422/485 cable shield **MUST** be connected between TITAN J1 pin 9 (GND) and the ground connection of the connecting equipment. Failure to do so can result in TITAN RS422/485 transceiver being permanently damaged.

---



Typical RS422 and RS485 connection

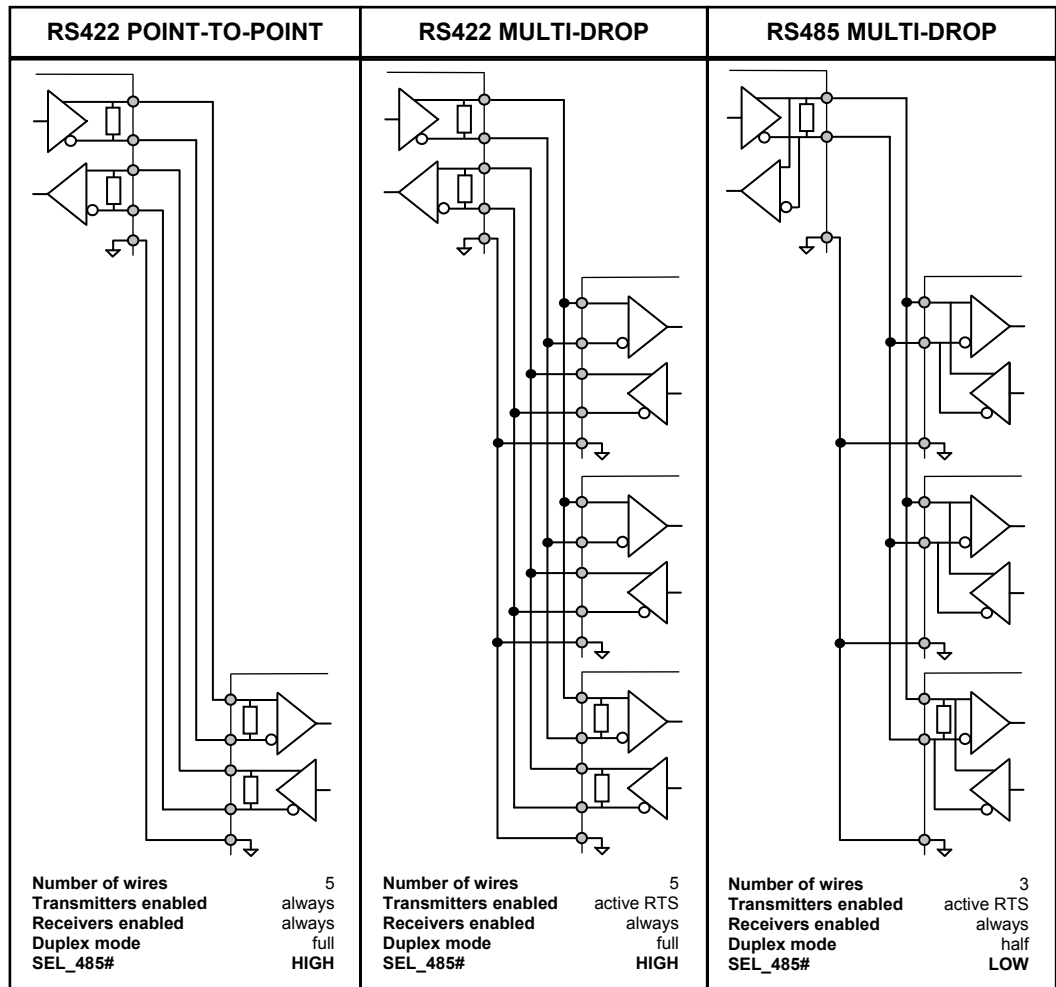

Only set SEL\_TERM to logic high if the TITAN is at the end of the network.

## I<sup>2</sup>C

The PXA270 I<sup>2</sup>C interface is brought out to the COMs connector J1. See the section [J1 – COMS ports](#), page 66, for connection details.

The I<sup>2</sup>C bus is also used with the Quick Capture interface. See the section [Quick Capture camera interface](#), page 51, for more information.

The following table lists the on-board I<sup>2</sup>C devices:

Device name	I <sup>2</sup> C address
External GPIO (MAX7313)	0x20
Temperature sensor (LM75A)	0x48
RTC (ISL1208)	0x6F
Config PROM (24AA01)	0x50-0x57

The I<sup>2</sup>C unit supports a fast mode operation of 400kbps and a standard mode of 100kbps.

Fast mode devices are downward compatible and can communicate with standard mode devices in a 0 to 100kbps I<sup>2</sup>C bus system. However, standard mode devices are not upward compatible, so they should not be incorporated in a fast mode I<sup>2</sup>C bus system as they cannot follow the higher transfer rate and unpredictable states would occur.

---

The I<sup>2</sup>C unit does not support the hardware general call, 10-bit addressing, high-speed mode (3.4Mbps) or CBUS compatibility.



You must keep bus loads added by the Quick Capture camera, and any other devices added to the serial communications connector, below 140pF.

Ensure any other devices added to the I<sup>2</sup>C interface do not have the same addresses as detailed in the table above.

---

## Quick Capture camera interface

The Quick Capture interface is a component of Intel® Quick Capture technology which provides a connection between the PXA270 processor and a camera image sensor. The Quick Capture interface is designed to work primarily with CMOS-type image sensors and supports resolutions up to 4 mega pixels. However, it may be possible to connect some CCD-type image sensors to the PXA27x processor, depending on the specific CCD sensor's interface requirements.

The Quick Capture interface acquires data and control signals from the image sensor and performs the appropriate data formatting prior to routing the data to memory using direct memory access (DMA). A broad range of interface and signalling options provides direct connection. The image sensor can provide raw data through a variety of parallel and serial formats. For sensors that provide pre-processing capabilities, the Quick Capture interface supports several formats for RGB and YCbCr colour space.

The Quick Capture interface signals are connected to the header J2. An I<sup>2</sup>C interface is available on the same header since most of the camera image sensors require an I<sup>2</sup>C control interface. For connector details see the section [J2 – Camera interface connector](#), page [67](#).

## General purpose I/O

A Maxim MAX7313 I<sup>2</sup>C I/O expander provides sixteen general purpose input/output lines on header J3. Each I/O port can be individually configured as either an open-drain current-sinking output rated at 50mA with a 10K pull-up to +5V (VCC\_PER), or a logic input with transition detection. The MAX7313 supports hot insertion and all inputs are +5V tolerant.

The MAX7313 can configure outputs for PWM current drive. The MAX7313 includes an internal oscillator, nominally 32kHz, to generate PWM timing for LED intensity control. PWM intensity control can be enabled on an output-by-output basis, allowing the MAX7313 to provide any mix of PWM LED drives and glitch-free logic outputs. PWM can be disabled entirely, in which case all output ports are static and the MAX7313 operating current is the lowest because the internal oscillator is turned off.

The I/O Expander is addressable at I<sup>2</sup>C serial bus address 0x20 and is accessed in fast-mode operation at 400kbps. On power-up all control registers are reset and the MAX7313 enters standby mode. Power-up status makes all ports into inputs, so the state of all 17 ports (P0-P16) is logic high (through 10K pull-up to 5V).

See the section [J3 – GPIO connector](#), page 67, for connector pinout and mating connector details. The signals on J3 correspond to the pin names of the MAX7313 (P0-P15).

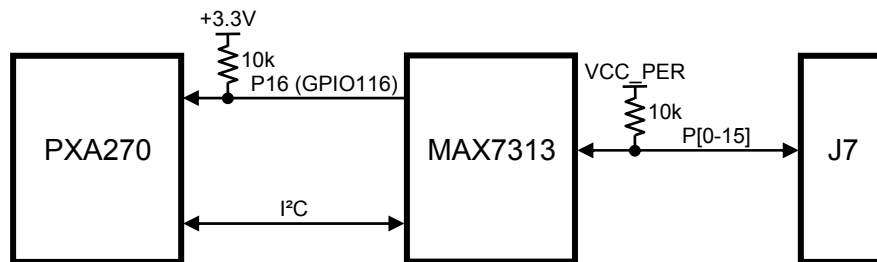

Port 16 of the MAX7313 is configured as an interrupt, so that any I/O Expander GPIO pin configured as an input can cause the PXA270 to be interrupted on GPIO116. These can also be used as PXA270 wake-up sources from sleep mode.

## Temperature sensor

There is a Philips LM75A temperature sensor on the TITAN. The LM75A is a temperature-to-digital converter using an on-chip band-gap temperature sensor and Sigma-delta A-to-D conversion technique. The device is also a thermal detector providing an over-temperature detection output (OVERTEMP signal on GPIO 12), which can be used to wake the PXA270 up from sleep. The accuracy of LM75A is  $\pm 2^{\circ}\text{C}$  (at  $-25^{\circ}\text{C}$  to  $100^{\circ}\text{C}$ ), and  $\pm 3^{\circ}\text{C}$  (at  $-55^{\circ}\text{C}$  to  $125^{\circ}\text{C}$ ). The LM75A is connected to the I<sup>2</sup>C bus of the PXA270 processor, and is accessible at I<sup>2</sup>C bus address 0x48.

## JTAG and debug access

Debug access to the PXA270 processor is via the JTAG connector J9. See [J9 – JTAG connector](#), page [71](#), for details.

Jumper JP6 needs to be inserted to enable the JTAG interface for PXA270 debug. See section [JP6 – JTAG enable](#), page [77](#) for details.

The Macraigor [Wiggler](#) and EPI [Majic<sup>MX</sup>](#) probe have been used to debug the PXA270 processor on the TITAN. There are many other debug tools that can be interfaced to the TITAN for access to the JTAG Interface of the PXA270 processor.

The tables below detail the pins connections between the TITAN and Macraigor [Wiggler](#) or EPI [Majic<sup>MX</sup>](#) debug tools. Of the [Wiggler](#) and [Majic<sup>MX</sup>](#) debug tools the [Wiggler](#) provides the best low cost solution.

### TITAN JTAG connections

TITAN J9			Debug tools pin names	
Pin	Name	Description	Majic <sup>MX</sup>	Wiggler
1	VCC3	3.3V Supply pin to JTAG debug tool	VTRef, VSupply	Vref, VTarget
3	GND	Ground reference	GND	GND
4	nTRST	PXA270 JTAG interface reset	nTRST	nTRST
6	TDI	JTAG test data input to the PXA270	TDI	TDI
7	TDO	JTAG test data output from the PXA270	TDO	TDO
8	TMS	PXA270 JTAG test mode select	TMS	TMS
9	TCK	PXA270 JTAG test clock	TCK	TCK
10	SRST	System reset	nSRST	nSRST
2, 5	NC	No Connect	-	-
-	-	Not required on TITAN.	RTCLK	RTCK
-	-	Not required on TITAN	DBGREQ	DBGRQ
-	-	Not supported by TITAN	DBGACK	DBGACK



In order to access the PXA270, your JTAG software needs to know the details of the two CPLDs on the TITAN. The latest version of the XC9536XL and XC9572XL BSDL files for the 48-ball chip scale package can be found on the [Xilinx](#) web site.

## Power and power management

### Power supplies

The TITAN is designed to operate from a single +5V  $\pm$ 5% (4.75V to +5.25V) supply. The power connector J15 has a +12V connection defined, but is not required for the TITAN under normal operation. It can be used to supply +12V to the PC/104 stack if required. For details of the power connector please see the section [J15 – Power connector](#), page [75](#).

### On-board supplies

There are eleven on-board supply voltages derived from the VCC (+5V) supply. They are listed in the following table:

Supply rail	Power domains	Voltage	Reset threshold
VCC_BATT	PXA270 sleep control subsystem, oscillators and real time clock.	3.3V or 3.0V	2.25V
VCC_CORE	PXA270 core and other internal units.	0.85V-1.55V	92% of nominal
VCC_PLL	PXA270 phase-locked loops.	1.3V	1.2V
VCC_SRAM	PXA270 internal SRAM units.	1.1V	1V
+3V3	PXA270 I/O, PXA270 internal units, on-board peripherals.	3.3V	3.05V
VCC_PER	PC/104, Audio amp, USB power switch, Video supplies (BKLSAFE / LCDSAFE), STN bias circuit, External GPIO.	5V (VCC)	NA
VBUS 1	USB port 1 power.	5V (VCC_PER)	NA
VBUS 2	USB port 2 power.	5V (VCC_PER)	NA
LCD_SAFE	LCD logic supply.	3.3V or 5V (VCC_PER)	NA
BKLSAFE	LCD backlight supply.	5V (VCC_PER)	NA
+2V8_CIF	CIF Camera interface.	2.8V	NA

The TITAN shall be reset if the supplies fall below the thresholds shown in the table.

VCC\_CORE, VCC\_PLL and VCC\_SRAM rails are controlled by the PXA270 hardware control signal PWR\_EN. They are switched off when PXA270 is in sleep or deep-sleep mode.

VCC\_PER, +3V3 and +2V8\_CIF supply rails are controlled by the PXA270 hardware control signal SYS\_EN. They are switched off when PXA270 is in deep-sleep mode.

VBUS 1 and VBUS 2 are controlled by the PXA270 software controlled signals USB\_PWE1 and USB\_PWE2 respectively. They are switched off on power-on, reset, sleep or deep-sleep.

LCD\_SAFE and BKLSAFE are controlled by the PXA270 software controlled signals LCDEN and BKLEN respectively. They are switched off on power-on, reset, sleep or deep-sleep.

---

Do NOT attempt to power the TITAN using the VCC\_PER, VBUS 1 or VBUS 2 pins!

VCC\_PER is an isolated +5V supply switched under hardware control from the VCC input on J15 pin 1. ALWAYS provide +5V to VCC on J15 pin 1.



VBUS 1 and VBUS 2 are isolated +5V supplies switched under hardware control from VCC\_PER.

If J15 pin 4 is used to supply +12V to the PC/104 connector J13 pin B4. Do NOT exceed 700mA supply current at 70°C (158°F) ambient, or 600mA at 85°C (185°F) ambient.

If an LCD display is used, ensure the total current requirement on 3.3V does not exceed 1.4A! Please check the datasheets of the devices you are using, as this supply is not protected!

---

## Power management IC

The Linear Technology LTC3445 is used to provide the power supply for PXA270. It is specifically designed for the PXA27x family of microprocessors.

The LTC3445 contains a high efficiency buck regulator (VCC\_CORE), two LDO regulators (VCC\_PLL, VCC\_SRAM), a PowerPath controller and an I<sup>2</sup>C interface. The buck regulator has a 6-bit programmable output range of 0.85V to 1.55V. The buck regulator uses either a constant frequency of 1.5MHz, or a spread spectrum switching frequency. Using the spread spectrum option (default set to 22.4%) gives a lower noise regulated output, as well as low noise at the input. In addition, the regulated output voltage slew rate is programmable via the Power Management I<sup>2</sup>C interface of the PXA270.

## Battery backup

An on-board non-rechargeable battery (CR2032) provides battery backup supply for the ISL1208 RTC and SRAM. An external battery (CR2032 or similar) may also be fitted. To use an external battery see the section [J15 – Power connector](#), page [75](#), for connection details.

The table below shows the typical and maximum current load on the external battery:

Device load on battery	Typical ( $\mu\text{A}$ )	Maximum ( $\mu\text{A}$ )
 On-board SRAM	0.5	3
ISL1208 RTC with clock out off	0.4	0.95
Supply supervisor	0.5	0.5
<b>Total</b>	<b>1.4</b>	<b>4.45</b>

Based on the worst-case figures of  $4.45\mu\text{A}$  current consumption, a 220mAh CR2032 battery cell will backup the TITAN (whilst in continuous deep sleep) for > 5 years.



The TITAN does not provide a battery charging circuit.



If the TITAN is to be used at operating temperature extremes, please be aware that if the battery cell is fitted they are typically rated at  $-30^{\circ}\text{C}$  to  $+60^{\circ}\text{C}$ .



## Processor power management

First available in the PXA270 processor, wireless Intel SpeedStep® technology dynamically adjusts the power and performance of the processor based on CPU demand. This can result in a significant decrease in power consumption.

In addition to the capabilities of Intel Dynamic Voltage Management, the Intel XScale micro architecture of the PXA27x family incorporates three new low power states. These are deep idle, standby and deep sleep. It is possible to change both voltage and frequency on the fly by intelligently switching the processor into the various low power modes. This saves additional power while still providing the necessary performance to run rich applications.

Wireless Intel SpeedStep® technology includes the following features:

- Five reset sources: power on, hardware, watchdog, GPIO and exit from sleep and deep sleep modes (sleep exit).
- Multiple clock speed controls to adjust frequency, including frequency change, turbo mode, half-turbo mode, fast-bus mode, memory clock, 13M mode, A-bit mode and AC '97.
- Switchable clock source.
- Functional unit clock gating.
- Programmable frequency change capability.
- One normal operation power mode (run mode) and five low power modes to control power consumption (idle, deep idle, standby, sleep and deep sleep modes).
- Programmable I<sup>2</sup>C-based external regulator interface to support changing dynamic core voltage, frequency change and power mode coupling.

PXA270 power consumption depends on the operating voltage and frequency, peripherals enabled, external switching activity and external loading and other factors. The tables below contain the power consumption information at room temperature for several operating modes: active, idle and low power modes. For active power consumption data, no PXA270 peripherals are enabled except for UART.

Frequency	System bus frequency	Active power consumption typ.	Idle power consumption typ.	Conditions VCC_SRAM = 1.1V; VCC_PLL = 1.3V; VCC_MEM, VCC_BB, VCC_USIM, VCC_LCD = 1.8V; VCC_IO, VCC_BATT, VCC_USB=3.0V
520 MHz	208 MHz	747 mW	222 mW	VCC_CORE = 1.45V
416 MHz	208 MHz	570 mW	186 mW	VCC_CORE = 1.35V
312 MHz	208 MHz	390 mW	154 mW	VCC_CORE = 1.25V
312 MHz	104 MHz	375 mW	109 mW	VCC_CORE = 1.1V
208 MHz	208 MHz	279 mW	129 mW	VCC_CORE = 1.15V
104 MHz	104 MHz	116 mW	64 mW	VCC_CORE = 0.9V
13 MHz	CCCR[CPDIS]=1	44.2 mW	-	VCC_CORE = 0.85V

PXA270 low power modes	Power consumption typ.	Conditions VCC_MEM, VCC_BB, VCC_USIM, VCC_LCD = 1.8V VCC_IO, VCC_BATT, VCC_USB= 3.0V
13MHz idle mode (LCD on)	15.4mW	VCC_CORE, VCC_SRAM, VCC_PLL = 0.85V
13MHz idle mode (LCD off)	8.5mW	VCC_CORE, VCC_SRAM, VCC_PLL = 0.85V
Deep sleep mode	0.1mW	VCC_CORE, VCC_SRAM, VCC_PLL = 0V
Sleep mode	0.16mW	VCC_CORE, VCC_SRAM, VCC_PLL = 0V
Standby mode	1.72mW	VCC_CORE, VCC_SRAM, VCC_PLL = 3.0V

## Wake-up sources







The PXA270 offers two sleep modes:

- *Sleep mode* offers lower power consumption by switching off most internal units. There is no activity inside the processor, except for the units programmed to retain their state in the PSLR register, the real time clock and the clocks and power manager. Because internal activity has stopped, recovery from sleep mode must occur through an external or internal real time clock event. External wake-up sources are GPIO<n> edge detects (they are listed in the section [PXA270 GPIO pin assignments](#), page 19).
- *Deep-sleep mode* offers the lowest power consumption by powering most units off. There is no activity inside the processor, except for the real time clock (RTC) and the clocks and power manager. Because internal activity has stopped, recovery from deep-sleep mode must be through an external event or an RTC event. In deep-sleep mode, all the PXA270 power supplies (VCC\_CORE, VCC\_SRAM, VCC\_PLL, VCC\_IO excluding VCC\_BATT) are powered off for minimized power consumption. On the TITAN, the main +3.3V rail supplies the VCC\_IO power domain of the PXA270. Since the +3.3V supply is switched off in deep-sleep mode, all the on-board peripherals are powered off and it is not possible to use external wake-up sources. In this situation, recovery from deep-sleep mode must be through an internal RTC event.

For more information on PXA270 power management, see section 3.6 in the *Intel PXA27x Processor Family Developer's Manual*, included on the Development Kit CD.

## Peripheral devices power management

The following table gives the estimated power consumption of on-board peripherals:

On-board peripheral	Maximum power consumption	Low power mode	
		Minimum consumption	Operating mode
Ethernet DM9000A	303.6mW (92mA at 3.3V)	23.1mW (7mA at 3.3V)	Power down
Eth config EEPROM	6.6mW (2mA at 3.3V)	0.003mW (1µA at 3.3V)	Idle
 AC'97 Codec WM9712L	80mW	0.001mW	OFF
 Boomer LM4880	250mW (50mA at 5V)	0.025mW (5µA at 5V)	Shut down
SDRAM x 2	1188mW (2 x 180mA at 3.3V)	13.2mW (2 x 2mA at 3.3V)	Power down
Flash	297mW (90mA at 3.3V)	0.015mW (5µA at 3.3V)	Standby
 SRAM	49.5mW (15mA at 3.3V)	0.0033mW (10µA at 3.3V)	Standby
 DUART	13.9mW (1.2mA at 3.3V) +	0.1mW (30µA at 3.3V)	Idle
RS232 x 2	(2 x 1.5mA at 3.3V) (unloaded)	2µW (2 x 0.3µA at 3.3V)	Shut down
 RS232	5mW (1.5mA at 3.3V) (unloaded)	1µW (0.3µA at 3.3V)	Shut down
 RS485/422	188.1mW (2mA at 3.3V) (unloaded) + (27.5mA x 2 at 3.3V) 120Ω enabled	0.003mW (1µA at 3.3V) + 120Ω disabled	Disable
CPLDs	75.9mW (23mA at 3.3V)	33mW (10mA at 3.3V)	Idle
 LVDS Transceiver	148.5mW (45mA at 3.3V)	0.17mW (55µA at 3V)	Power down
Clock Generators	121.1mW (37mA at 3.3V)	33µW (10µA at 3.3V)	Shut down
I/O expander	40.4mW (120µA at 3.3V) + (8mA at 5V)	11.9µW (3.6µA at 3.3V)	Idle
RTC	0.4mW (120µA at 3.3V)	0.013mW (4µA at 3.3V)	Idle
Temperature Sensor	3.3mW (1mA at 3.3V)	0.012mW (3.5µA at 3.3V)	Shut down
Config PROM	3.3mW (3mA at 3.3V)	0.003mW (1µA at 3.3V)	Standby
<b>Total</b>	<b>2774.6mW</b>	<b>135.6mW</b>	

External peripheral devices include two USB devices (5W max), add-on PC/104 cards (5W max), LCD and inverter (4W max), SDIO (350mW max) and Quick Capture camera (50mW max).

The table below gives examples of the power drawn by specific external peripheral devices:

Device	Part number	Condition	Power (mW)
Socket WiFi 802.11b SDIO	WL6200-480	Idle (listening)	50
		Transmitting	925
64MB FlashDio™ USB memory stick	FDU100A	Inserted (no access)	375
		Reading consistently	605
NEC 5.5" LCD + inverter	NL3224BC35-20 + 55PW131	LCD and backlight on	3250
		LCD on and backlight off	825
VGA CMOS sensor module	Dialog DA3520	Active	50

## COMs power management

GPIO 20 on the PXA270 can be used to power down the RS232 transceivers on COM1, 2, 3 and 4. The following table shows the effect of GPIO 20 on the RS232 transceivers:

RS232_SHDN# (GPIO 20)	Operation status	Transmitters	Receivers
0	Normal operation	Active	Active
1	Shutdown	High-Z	High-Z

Shut can reduce the consumption of the RS232 transceivers down to near zero (3µW).



COM4 and COM5 are generated from an external Exar XR16C2850 DUART. This device supports a sleep mode with an auto wake up. By enabling this feature the DUART enters sleep mode when there are no interrupts pending. The device resumes normal operation when any of the following occur:

- Receive data start bit.
- Change of state on: CTS, DSR, CD, RI.
- Data is being loaded into transmit FIFO.

If the device is awake by one of the above conditions, it returns to the sleep mode automatically after the condition has cleared. In sleep mode the XR16C2850 consumes 0.1mW. Please see the *XR16C2850 datasheet* on the Development Kit CD for information on enabling the sleep mode.

GPIO115 on the PXA270 is used to connect or disconnect the 120Ω termination resistors on COM5.

SEL_TERM (GPIO 115)	COM5 termination resistors (120Ω)
0	Disconnected
1	Connected [default]

## Ethernet power management

The Ethernet controller (Davicom DM9000A) incorporates a number of features to maintain the lowest power possible.

The device can be put into a power-reduced mode by setting the PHY control register bit 16.4. In power-reduced mode, the device transmits the fast link pulses with minimum power consumption. It also monitors the media for the presence of a valid signal and, if detected, the device automatically wakes up and resumes normal operation. The power consumption in power-reduced mode (without cable) is 31mA, 102.3mW.

The PHY can be put into a sleep mode by setting the PHY control register bit 16.1, which powers down all the circuits except the oscillator and clock generator circuit.

The PHY can be put into a power-down mode by setting the PHY control register bit 0.11 which disables all transmit and receive functions but not the access to PHY registers. The power consumption in power-down mode is 21mA, 69.3mW.

The lowest power consumption is achieved when the system clock is turned off by setting bit 0 in the SCCR register to reduce power consumption down to 7mA, 23.1mW.

For more information about power management, refer to the DM9000A datasheet on the Development Kit CD.

## USB power management



A USB power control switch controls the power and protects against short-circuit and over-current conditions on USB host ports.

If the USB voltage VBUSx is short-circuited, or more than 500mA is drawn from any VBUSx supply, the switch turns off the power supply and protects the device and board automatically. The VBUSx power supplies are derived from the TITAN +5V supply.

The following table shows the PXA270 assignments for power enable and over-current signals:

GPIO	Host 1/2 functions	Active
GPIO 89	USB_PWE1	High
GPIO 88	USB_OC1#	
GPIO 22	USB_PWE2	High
GPIO 114	USB_OC2#	

## Audio power management



The audio CODEC Wolfson WM9712L supports the standard power down control register defined by AC'97 standard (26h). In addition, the individual sections of the chip can be powered down through register 24h. Significant power savings can be achieved by disabling parts of WM9712L that are not used.

Shutting down all the clocks and digital and analogue sections can reduce WM9712L consumption down to near zero (1.65µW).

For more information about power management, refer to the WM9712L datasheet contained on the Development Kit CD.

## LVDS power management



If the LVDS transmitter is not required it can be placed in power down mode by applying a high level to the PXA270 GPIO 21 LVDS\_EN signal. The power consumption in power down mode is 180µW. This is shown in the following table:

LVDS_EN (GPIO 21)	LVDS operation status
0	LVDS power down (default)
1	LVDS enable

## Clock generator power management

Two clock synthesizer ICs (Cypress CY22381) can be placed in low power mode by shutting down the clock outputs when the corresponding interfaces are not used. To put these into low power mode, apply a low level to GPIO 18 pin on the PXA270 (signal CLK\_SHDN#).

CLK_SHDN# (GPIO 18)	Clock operation status
0	Shutdown clocks
1	Clocks running

Once shutdown the following clocks are affected:

- 8MHz and 14.318MHz PC/104 clocks.
- 14.7456MHz DUART clock.
- 24.576MHz audio clock.
- 25MHz Ethernet PHY clock.

This reduces the power consumption of the clock generators down to 33µW.

## Temperature sensor power management

The LM75A device can be set to operate in two modes: normal or shut down. In normal operation mode, the temp-to-digital conversion is executed every 100ms and the Temp register is updated at the end of each conversion. In shut down mode, the device becomes idle, data conversion is disabled and the Temp register holds the latest result; however, the device I<sup>2</sup>C interface is still active and register write/read operation can be performed. The device operation mode is controllable by programming bit B0 of the configuration register. The temperature conversion is initiated when the device is powered-up or put back into normal mode from shut-down. The power consumption in shut-down mode is near zero (11.5 $\mu$ W).

For more information about power management, refer to the *LM75A datasheet* contained on the Development Kit CD.

## I/O expander power management

When the serial I<sup>2</sup>C interface is idle and the PWM intensity control is unused, the MAX7313 automatically enters standby mode. If the PWM intensity control is used, the operating current is slightly higher because the internal PWM oscillator is running. The power consumption in standby mode (with PWM disabled) is near zero (3.6 $\mu$ W).

The IO expander has 10k $\Omega$  pull-up resistors on P0-15. Dependant on which of these signals are configured as input or output, or what logic level each output is configured at during sleep determines the current attributed by these resistors during sleep.

P0-15 direction	Current / Watts each	Current / Watts all
Input (floating)	0mA / 0mW	0mA / 0mW
Input high (VCC_PER)	0mA / 0mW	0mA / 0mW
Input high (3.3V)	0.17mA / 0.29mW	2.72mA / 4.62mW
Input low (0V)	0.5mA / 2.5mW	8mA / 40mW
Output logic level low (no further pull-ups at termination)	0.5mA / 2.5mW	8mA / 40mW
Output logic level high (loaded and no further pull-ups at termination)	0.5mA / 2.5mW (max)	8mA / 40mW (max)
Output logic level high (no load)	0mA / 0mW	0mA / 0mW

Set up the IO expander P0-15 signals accordingly to your application to achieve the optimum power savings during sleep.

If none of the IO expander P0-15 signals are used set them all to be inputs.

## Configuration PROM power management

When the serial I<sup>2</sup>C interface is idle the 24AA01 automatically enters standby mode. The power consumption in standby mode is near zero (3.3 $\mu$ W).



## Connectors, LEDs and jumpers

The following diagram shows the location of the connectors, LEDs and jumpers on the TITAN:

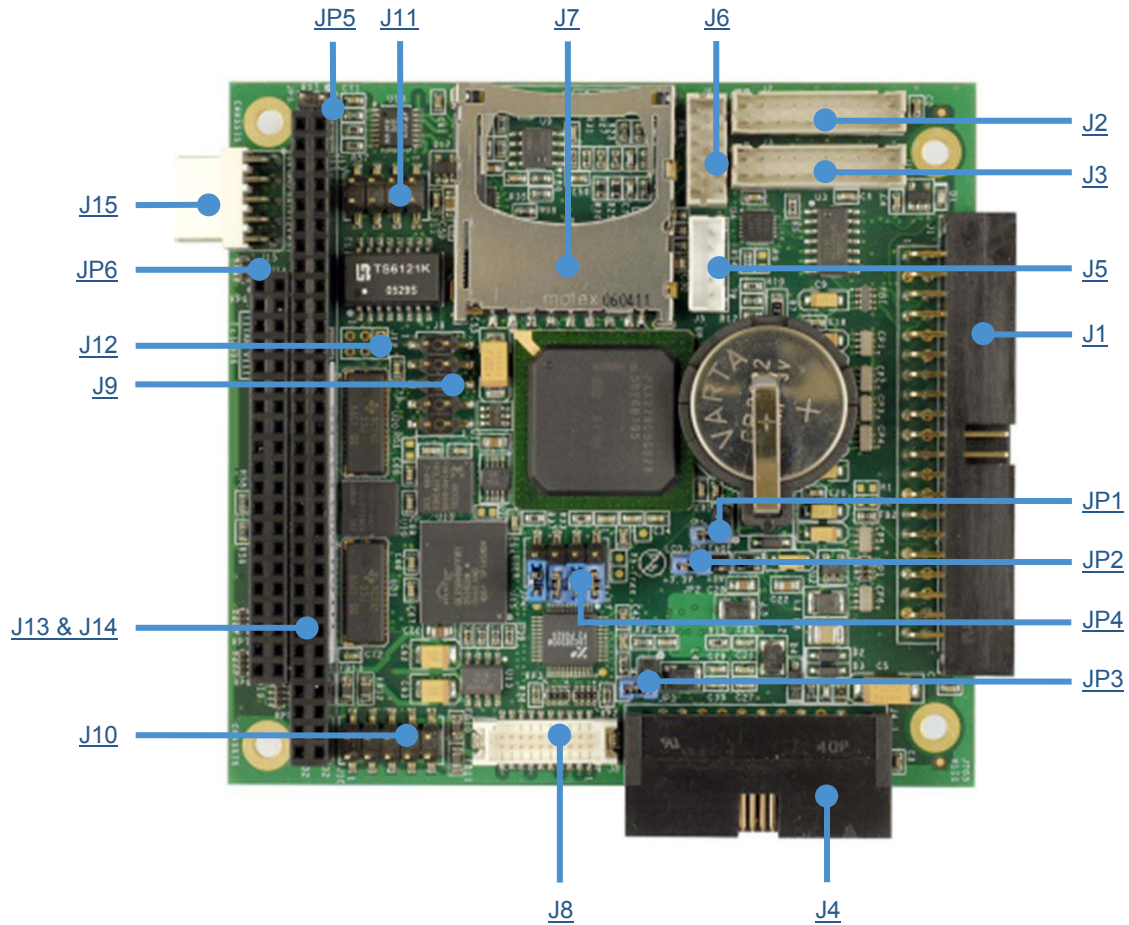







The connectors on the following pages are shown in the same orientation as the picture above, unless otherwise stated.



## Connectors

There are 12 connectors on the TITAN for accessing external devices.

Connector	Function	Connector details in section
J1	Serial ports	<a href="#">J1 – COMS ports, page 66</a>
J2	Camera	<a href="#">J2 – Camera interface connector, page 67</a>
J3	GPIO	<a href="#">J3 – GPIO connector, page 67</a>
J4	LCD panel interface	<a href="#">J4 – LCD connector, page 68</a>
 J5	Touchscreen	<a href="#">J5 – Touchscreen connector, page 69</a>
 J6	Audio	<a href="#">J6 – Audio connector, page 69</a>
J7	SDIO	<a href="#">J7 – SDIO socket, page 70</a>
 J8	LVDS interface	<a href="#">J8 – LVDS connector, page 71</a>
J9	JTAG	<a href="#">J9 – JTAG connector, page 71</a>
J10	USB	<a href="#">J10 – USB connector, page 72</a>
J11	10/100BaseTX Ethernet interface	<a href="#">J11 – 10/100BaseTX Ethernet connector, page 72</a>
J12	Ethernet controller status LEDs	<a href="#">J12 – Ethernet status LEDs connector, page 73</a>
 J13	64-way PC/104 expansion	<a href="#">J13 &amp; J14 – PC/104 connectors, page 74</a>
 J14	40-way PC/104 expansion	<a href="#">J13 &amp; J14 – PC/104 connectors, page 74</a>
J15	Power / battery / external reset	<a href="#">J15 – Power connector, page 75</a>
 JP1	Battery disconnect	<a href="#">JP1 – Battery disconnect, page 75</a>
JP2	LCD logic supply selection	<a href="#">JP2 – LCD logic supply selection, page 76</a>
 JP3	LVDS MSL selection	<a href="#">JP3 – LVDS MSL selection, page 76</a>
JP4	User / Recovery link selection	<a href="#">JP4 – User / Recovery link selection, page 76</a>
JP5	External reset	<a href="#">JP5 – External reset, page 76</a>
JP6	JTAG enable	<a href="#">JP6 – JTAG enable, page 77</a>

### J1 – COMS ports

**Connector:** Oupiin 3014-40GRB/SN, 40-way, 2.54mm (0.1") x 2.54mm (0.1") dual row IDC boxed header

**Mating connector:** FCI 71600-040LF

Pin	Signal name	Pin	Signal name	
1	SCL (I <sup>2</sup> C )	2	SDA (I <sup>2</sup> C )	I <sup>2</sup> C
3	GND (I <sup>2</sup> C )	4	+3V3 (I <sup>2</sup> C )	
5	TX5+ (RS422) (TX5+/RX5+ RS485)	6	TX5- (RS422) (TX5-/RX5- RS485)	COM5
9	GND	10	GND	COM3
11	TX3	12	RX3	
13	RX2	14	RTS2	COM2
15	TX2	16	CTS2	
17	GND	18	GND	
19	GND	20	NC	
21	DCD4	22	DSR4	COM5
25	TX4	26	CTS4	
27	DTR4	28	RI4	
29	GND	30	NC	
31	DCD1	32	DSR1	COM1
33	RX1	34	RTS1	
35	TX1	36	CTS1	
37	DTR1	38	RI1	
39	GND	40	NC	

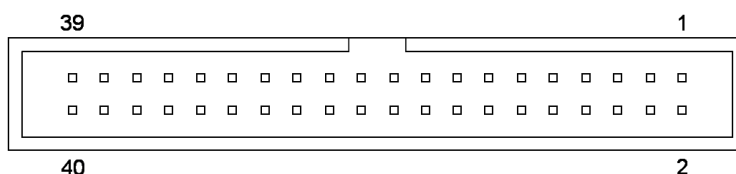

As viewed from the connector pins

## J2 – Camera interface connector

**Connector:** Neltron 2417SJ-20-PHD 'LEAD FREE', 20-way, 2mm (0.079") header

**Mating connector:** JST PHDR-20VS

**Mating crimps:** JST SPHD-002T-P0.5

Pin	Signal name	Pin	Signal name
1	+3V3	2	+2V8
3	CIF_MCLK	4	CIF_PCLK
5	CIF_LV	6	CIF_FV
7	CIF_DD0	8	CIF_DD1
9	CIF_DD2	10	CIF_DD3
11	CIF_DD4	12	CIF_DD5
13	CIF_DD6	14	CIF_DD7
15	I2C_SCL	16	I2C_SDA
17	CIF_DD8	18	CIF_DD9
19	GND	20	GND

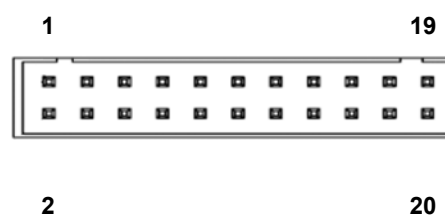

## J3 – GPIO connector

**Connector:** Neltron 2417SJ-20-PHD 'LEAD FREE', 20-way, 2mm (0.079") header

**Mating connector:** JST PHDR-20VS

**Mating crimps:** JST SPHD-002T-P0.5

Pin	Signal name	Pin	Signal name
1	VCC_PER (+5V)	2	VCC_PER (+5V)
3	P0	4	P1
5	P2	6	P3
7	P4	8	P5
9	P6	10	P7
11	GND	12	GND
13	P8	14	P9
15	P10	16	P11
17	P12	18	P13
19	P14	20	P15

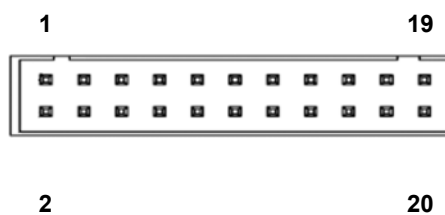

Do NOT attempt to power the TITAN using the VCC\_PER pins!

VCC\_PER is an isolated +5V supply switched under hardware control from the VCC input on J15 pin 1. ALWAYS provide +5V to VCC on J15 pin 1.

## J4 – LCD connector

**Connector:** Oupiin 3214-40C00RBA/SN, 40-way, 1.27mm (0.05") x 2.54mm (0.1") right angled boxed header

**Mating connector:** Oupiin 1203-40GB/SN (available from Eurotech on request)

Pin	Signal name	Pin	Signal name
1	BLKEN#	2	BLKSAFE
3	GPIO 16/PWM0	4	LCDSAFE
5	NEGBIAS	6	POSBIAS
7	GND	8	GND
9	FPD1	10	FPD0
11	FPD3	12	FPD2
13	FPD5	14	FPD4
15	GND	16	GND
17	FPD7	18	FPD6
19	FPD9	20	FPD8
21	FPD11	22	FPD10
23	GND	24	GND
25	FPD13	26	FPD12
27	FPD15	28	FPD14
29	FPD17	30	FPD16
31	GND	32	GND
33	BIAS / DE	34	GND
35	FCLK / VSYNC	36	GND
37	LCLK / HSYNC	38	GND
39	PCLK / CLOCK	40	GND

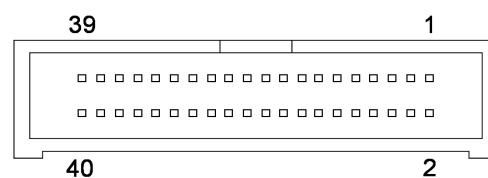

As viewed from the connector pins

**J5 – Touchscreen connector**

**Connector:** Neltron 2417SJ-05-F4, 5-way, 2mm (.079") Pitch Wire-to-Board Header

**Mating connector:** Molex 87369-0500, 2mm (.079") Pitch Crimp Housing

**Mating crimps:** Molex 50212

Pin	Signal name
1	TSRY+/TR
2	TSRY-/BL
3	TSRX+/BR
4	TSRX-/TL
5	TSW

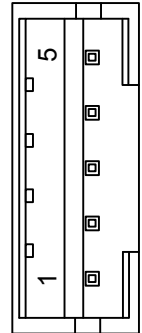
**J6 – Audio connector**

**Connector:** Neltron 2417SJ-12-PHD, 12-way, 2mm header

**Mating connector:** JST PHDR-12VS

**Mating crimps:** JST SPHD-002T-P0.5

Pin	Signal name	Pin	Signal name
1	LEFT IN	2	LEFT OUT
3	GND	4	GND
5	RIGHT IN	6	RIGHT OUT
7	GND	8	AMP LEFT OUT
9	MIC VREF OUT	10	MIC IN
11	AMP RIGHT OUT	12	GND

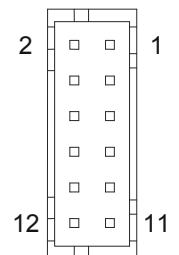

## J7 – SDIO socket

**Connector:** Molex 67840-8001, 2.50mm (.098") pitch SD memory card connector

Pin	Signal name
1	MMDAT3
2	MMCMD
3	GND
4	+3V3
5	MMCLK
6	GND
7	MMDAT0
8	MMDAT1
9	MMDAT2
10	MMC_WP
11	+3V3
12	MMC_CD

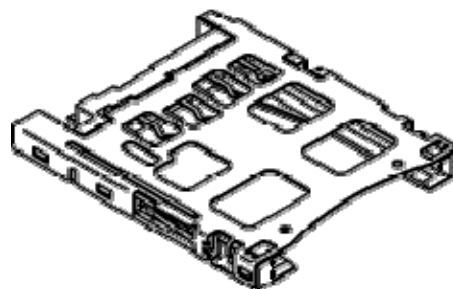

**J8 – LVDS connector**

**Connector:** Hirose DF13-20DP-1.25V(55), 20-way, 1.27mm (0.05") double row straight pin header

**LVDS mating connector:** Hirose DF13-20DS-1.25C

**LVDS mating connector crimps:** Hirose DF13-2630SCFA

**Eurotech recommended cable:** Amphenol 165-2899-945

Pin	Signal name	Pin	Signal name
1	+3V3	2	+3V3
3	GND	4	GND
5	LVDS_D0-	6	LVDS_D0+
7	GND	8	LVDS_D1-
9	LVDS_D1+	10	GND
11	LVDS_D2-	12	LVDS_D2+
13	GND	14	LVDS_CLK-
15	LVDS_CLK+	16	GND
17	NC	18	NC
19	GND	20	MSL

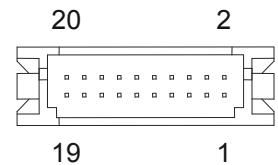
**J9 – JTAG connector**

**Connector:** Oupiin 2015-2X5GDB/SN, 10-way, 2.54mm (0.1") x 2.54mm (0.1") dual row header

**Mating connector:** FCI 71600-010LF

Pin	Signal name	Pin	Signal name
1	+3V3	2	NC
3	GND	4	nTRST
5	NC	6	TDI
7	TDO	8	TMS
9	TCLK	10	SRST

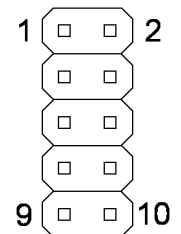

### J10 – USB connector



**Connector:** Oupiin 2015-2X5GDB/SN, 10-way, 2.54mm (0.1") x 2.54mm (0.1") dual row header

**Mating connector:** FCI 71600-010LF

Pin	Signal name	Pin	Signal name
1	VBUS 1	2	VBUS 2
3	DATA- 1	4	DATA- 2
5	DATA+ 1	6	DATA+ 2
7	GND	8	GND
9	SHIELD	10	SHIELD

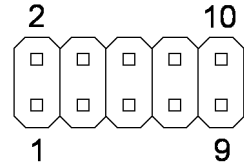

Do NOT attempt to power the TITAN using the VBUS 1 or VBUS 2 pins!

VBUS 1 and VBUS 2 are isolated +5V supplies switched under hardware control from VCC\_PER.



ALWAYS use the USB client cable provided with the development kit. This cable does not provide power down the cable and avoids reverse powering the TITAN from a USB host when the TITAN has no power on the VCC input on J15 pin 1. Reverse powering the TITAN from the VBUSn pins can make the TITAN operate erratically and may cause serious damage to the TITAN.

### J11 – 10/100BaseTX Ethernet connector

**Connector:** Oupiin 2015-2X4GDB/SN, 8-way, 2.54mm (0.1") x 2.54mm (0.1") dual row header

**Mating connector:** FCI 71600-008LF

Pin	Signal name	Pin	Signal name
1	TX+	2	TX-
3	RX+	4	NC
5	NC	6	RX-
7	NC	8	LANGND

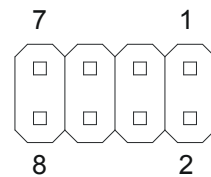



**J12 – Ethernet status LEDs connector**

**Connector:** Neltron 2417SJ-06-PHD, 6-way, 2mm (0.079") x 2mm (0.079") pin housing

**Mating connector:** Neltron 2418HJ-06-PHD

**Mating connector crimps (x4):** Neltron 2418TJ-PHD

Pin	Signal name	Pin	Signal name
1	+3V3	2	LINK
3	+3V3	4	SPEED
5	+3V3	6	NC

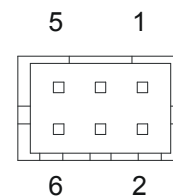

### J13 & J14 – PC/104 connectors



**Connectors:**

- Astron 25-1201-232-2G-R, 64-way, 2.54mm (0.1") x 2.54mm (0.1") stackthrough PC/104 compatible connector (row A & B)
- Astron 25-1201-220-2G-R, 40-way, 2.54mm (0.1") x 2.54mm (0.1") stackthrough PC/104 compatible connector (row C & D)

J14			J13		
Pin	Row D	Row C	Pin	Row A	Row B
			1	/IOCHCK	GND
			2	D7	RSTDRV
			3	D6	VCC_PER (+5V)
			4	D5	IRQ9
			5	D4	NC
			6	D3	NU (DRQ2)
			7	D2	NC
			8	D1	NC
0	GND	GND	9	D0	+12V
1	/MEMCS16	/SBHE	10	IOCHRDY	KEY
2	/IOCS16	LA23	11	AEN	/SMEMW
3	IRQ10	LA22	12	A19	/SMEMR
4	IRQ11	LA21	13	A18	/IOW
5	IRQ12	LA20	14	A17	/IOR
6	IRQ15	LA19	15	A16	NU (DACK3)
7	IRQ14	LA18	16	A15	NU (DRQ3)
8	NU (DACK0)	LA17	17	A14	NU (DACK1)
9	NU (DRQ0)	/MEMR	18	A13	NU (DRQ1)
10	NU (DACK5)	/MEMW	19	A12	NU (REFSH)
11	NU (DRQ5)	D8	20	A11	8MHz CLK
12	NU (DACK6)	D9	21	A10	IRQ7
13	NU (DRQ6)	D10	22	A9	IRQ6
14	NU (DACK7)	D11	23	A8	IRQ5
15	NU (DRQ7)	D12	24	A7	IRQ4
16	VCC_PER (+5V)	D13	25	A6	IRQ3
17	NC (Master)	D14	26	A5	NU (DACK2)
18	GND	D15	27	A4	NU (TC)
19	GND	KEY	28	A3	BALE
			29	A2	VCC_PER (+5V)
			30	A1	OSC
			31	A0	GND
			32	GND	GND

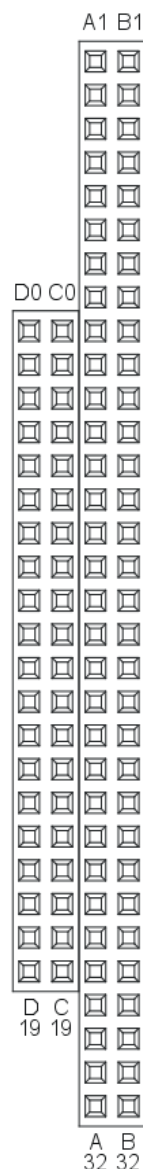

Do NOT attempt to power the TITAN using the VCC\_PER pins! VCC\_PER is an isolated +5V supply switched under hardware control from the VCC input on J15 pin 1. ALWAYS provide +5V to VCC on J15 pin 1.

## J15 – Power connector

**Connector:** Molex 22-05-7058, 5-way, 2.54mm (0.1") Pitch KK<sup>®</sup> header - right angle friction lock 7395 series connector

**Mating connector:** Molex 22-01-2055, 5-way, 2.54mm (0.1") Pitch KK<sup>®</sup> crimp terminal housing 2695 series connector

Pin	Signal name
1	VCC (+5V)
2	GND
3	VBAT_E
4	+12V
5	/Reset

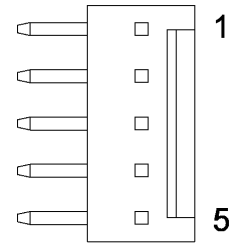

VBAT\_E provides the facility to fit an external battery for the backup supply of the external 256KByte static RAM and RTC, and internal 256KByte static RAM and RTC.



A +12V connection is defined, but is not required for the TITAN under normal operation. It can be used to supply +12V to the PC/104 stack if required.

A momentary switch (push to make) may be connected across /Reset and GND. Do NOT connect the switch across /Reset and VCC or +12V.

## JP1 – Battery disconnect



**Connector:** Oupiin 2011-1x2GSB/SN, 2-way, 2.54mm (0.1") single row through-hole header.

Pin	Signal name
1	Battery backup switch input
2	Battery + terminal



## JP2 – LCD logic supply selection

**Connector:** Oupiin 2011-1x3GSB/SN, 3-way, 2.54mm (0.1") single row through-hole header.

Pin	Signal name
1	VCC_PER (+5V)
2	LCD logic supply
3	+3V3



## JP3 – LVDS MSL selection



**Connector:** Oupiin 2011-1x2GSB/SN, 2-way, 2.54mm (0.1") single row through-hole header.

Pin	Signal name
1	MSL
2	+3V3

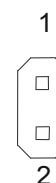

## JP4 – User / Recovery link selection

**Connector:** Oupiin 2015-2x4GDB/SN, 8-way, 2.54mm (0.1") dual row surface mount header.

Pin	Signal name	Pin	Signal name
1	GND	2	USER_LINKA
3	GND	4	USER_LINKB
5	GND	6	USER_LINKC
7	GND	8	RECOVERY

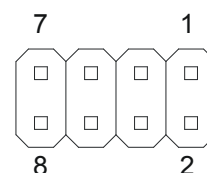

## JP5 – External reset

**Connector:** Oupiin 2011-1x2GSB/SN, 2-way, 2.54mm (0.1") single row through-hole header.

Pin	Signal name
1	/Reset
2	+GND



### JP6 – JTAG enable

**Connector:** Oupiin 2011-1x2GSB/SN, 2-way, 2.54mm (0.1") single row through-hole header

Pin	Signal name
1	VCC (+5V)
2	VCC_JTAG

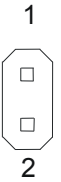

This jumper is used to enable debug of PXA270 using JTAG interface.

JP6	Description
	JTAG Enable
	Normal Operation (Default)



Only insert jumper for JTAG access to PXA270. The jumper **MUST** be removed when the JTAG interface is not in use.

## Status LEDs

There is a single status LED on the TITAN, which indicates FLASH access to the FLASH memory / silicon disk.

## Jumpers

There are nine user selectable jumpers on the TITAN; the use of each one is explained below.

### Default settings

The factory default positions of the jumpers are shown below. Jumper functions described in silkscreen on the board are shown in blue.

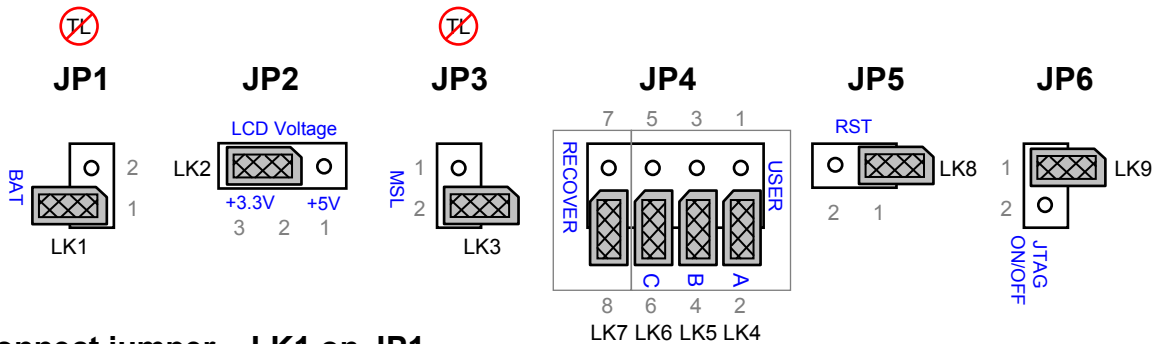

### Battery connect jumper – LK1 on JP1



This jumper connects the battery to the battery back-up circuit:



LK1	Description
	Battery supply connected.
	Battery supply disconnected [factory default].



If SRAM and/or RTC data is to be used, jumper LK1 must be fitted to JP1 to provide battery power to these devices. The jumper is left unconnected at the factory to conserve battery power.

### LCD supply voltage jumper – LK2 on JP2

This jumper selects the supply voltage for the LCD logic supply:

LK2	Description
	Supply LCD logic with 5V.
	Supply LCD logic with 3.3V [factory default].





If the LCD requires a 5V supply, please refer to the LCD datasheet to ensure that the display is compatible with 3.3V logic.

### LVDS mode select [MSL] jumper – LK3 on JP3



This jumper sets the MSL signal on the Hirose LVDS connector J8 to either high or low:

LK3	Description
	+3V3.
	Pulled to GND [factory default].





This jumper is only applicable if using the Hirose LVDS connector J8.

Please refer to LVDS LCD datasheet for details of the signal level that is required to set it up to receive LVDS signal mapping for a National Semiconductor DS90C363 LVDS transceiver.

## User configurable jumpers A to C – LK4-LK6 on JP4

These jumpers can be used to signify a configuration setting for your own application program:



LK4 – LK6	Description
	Read as '0'.
	Read as '1' [factory default].

---

 USER\_LINKA to C, LK4, 5 and 6 respectively (GPIO 13, 35 and 113 respectively), may be used to wake the TITAN from sleep. One way of doing this is to connect a momentary push to make switch across the USER\_LINK and GND.

## Recovery jumper – LK7 on JP4

This jumper can be used to recover a damaged software image:

LK7	Description
	Fetch working image from BOOTP server and execute.
	Normal software run mode [factory default].

---

 Please contact Eurotech for details. Contact details are provided in [Eurotech Group Worldwide Presence](#), page 101.



## Reset – LK8 on JP5

A momentary switch (push to make) may be connected to LK1. When pressed the board goes into a full hardware reset. When the switch is released (open circuit) the board reboots.



### JTAG enable jumper – LK9 on JP6

This jumper is used to enable debug of PXA270 using the JTAG interface:

LK9	Description
	JTAG enable.
	Normal operation [factory default].



Only insert jumper LK9 for JTAG access to the PXA270. LK9 MUST be removed before putting the TITAN into deep sleep.

## Appendix A - Board version / issue

Where it is possible to see the TITAN, the board version and issue are indicated on the top side in the upper right-hand corner and on the bottom side in the lower-left corner as shown below.

**TITAN version/issue on top side**

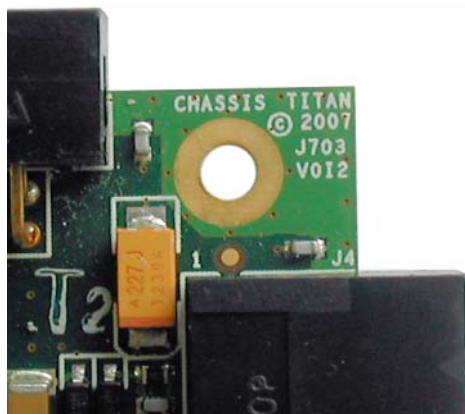

**TITAN version/issue on bottom side**

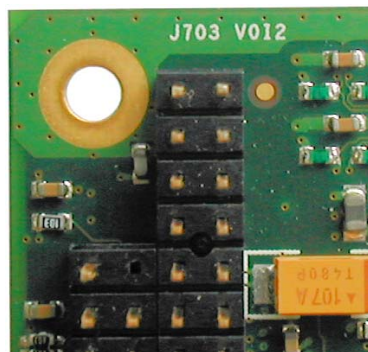

If it is not possible to physically look at the TITAN, the board version and issue can be read from the CPLD board version / issue register [BV\_REG] at the address 0x11000000. The board version and issue bit assignments are detailed in the table below:

### Board version/issue register [BV\_REG]

Byte lane	Most significant byte								Least significant byte							
Bit	15	14	13	12	11	10	9	8	7	6	5	4	3	2	1	0
Field	-	-	-	-	-	-	-	-	VERSION (BCD)				ISSUE (BCD)			
Reset	X	X	X	X	X	X	X	X	Current version				Current issue			
R/W	-	-	-	-	-	-	-	-	R							
Address	0x11000000															

### Mod box

The mod box indicates the ECO level that the TITAN is at for a particular version / issue of the board. The mod box is located on the bottom side behind the video connector J4, as shown below:









### CPLD versions

The TITAN CPLD versions can be read out of the CPLD versions register [CV\_REG] at the address 0x12000000. The CPLD versions bit assignments are detailed in the table below:

#### CPLD versions register [CV\_REG]

Byte lane	Most significant byte								Least significant byte							
Bit	15	14	13	12	11	10	9	8	7	6	5	4	3	2	1	0
Field	-	-	-	-	-	-	-	-	0	VERSION (BCD)			0	VERSION (BCD)		
Reset	X	X	X	X	X	X	X	X	0	CPLD 2 version			0	CPLD 1 version		
R/W	-	-	-	-	-	-	-	-	R							
Address	0x12000000															

## Appendix B - Specification

<b>Microprocessor</b>	PXA270 312MHz (TITAN-Lite only) 416/520MHz XScale processor (520MHz as standard option).
<b>Cache</b>	32K data cache, 32K instruction cache, 2K mini data cache.
<b>System memory</b>	Fixed on-board memory: <ul style="list-style-type: none"> <li>• 64MB SDRAM (32-bit wide SDRAM data bus).</li> <li> • 128MB SDRAM may be available in the future.</li> </ul>
<b>Silicon disk</b>	Fixed on-board memory: <ul style="list-style-type: none"> <li>• 16MB Flash (TITAN-Lite only).</li> <li> • 32/64MB Flash.</li> </ul>
<b>SRAM</b>	 256KB of SRAM battery backed on-board. 256KB of SRAM internal to PXA270.
<b>Serial ports</b>	Five UART 16550 compatible fast serial ports (921.6Kbaud): <ul style="list-style-type: none"> <li>• RS232 on COM1, COM2, COM3 and COM4.</li> <li> • RS422/485 on COM5 - software selectable.</li> </ul>
<b>USB support</b>	Two USB 1.1 host controller ports. One USB 1.1 client controller port (software selectable on Host 2).
<b>Network support</b>	One IEEE 802.3u 10/100Base-T NIC port. Option for external PoE.
<b>Expansion interfaces</b>	SDIO socket to support MMC/SD/SDIO cards. 16-bit PC/104 interface.
<b>Date/time support</b>	Real time clock - battery backed on-board. Accuracy +/- 1min/month.
<b>Video</b>	18-bit flat panel interface for STN and TFT displays. Supported resolutions: <ul style="list-style-type: none"> <li>• 320 x 240, 8/16/18 bpp.</li> <li>• 640 x 480, 8/16/18 bpp.</li> <li>• 800 x 600, 8/16/18 bpp.</li> <li> Optional LVDS interface.</li> </ul>
<b>Audio and touchscreen</b>	 AC'97 compatible CODEC, stereo. 20Hz to 20kHz in/out frequency response . Touchscreen support - 4/5-wire analogue resistive.
<b>Quick Capture camera interface</b>	Intel® Quick Capture technology.
<b>I<sup>2</sup>C bus</b>	Multi-master serial bus.
<b>Configuration PROM</b>	128 byte I <sup>2</sup> C configuration EEPROM.

<b>Watchdog timer</b>	Internal to PXA270, causes reset on timeout; timeout range 307ns-1321s.
<b>Real time clock</b>	Accuracy +/- 1 minute/month.
<b>General I/O</b>	16 x general purpose I/O.
<b>Temperature sensor</b>	I <sup>2</sup> C temperature sensor.
<b>Test support</b>	JTAG interface.
<b>Power requirements</b>	5V +/-5%. Consumption: 1.5W typical (no LCD, PC/104, USB, SDIO devices fitted). Sleep mode: 20mA (100mW) typical. Deep sleep mode: 2mA (10mW) typical.
<b>Mechanical</b>	PC/104 compatible format: 3.775" x 3.550", 96mm x 91mm (see <a href="http://www.pc104.org">www.pc104.org</a> ). 90 grams.
<b>Environmental</b>	Operating temperature: <ul style="list-style-type: none"><li>• Commercial: -20°C (-4°F) to +70°C (+158°F)</li><li>• Industrial: -40°C (-40°F) to +85°C (+185°F)</li></ul> Humidity: 10% to 90% RH (non-condensing) RoHS Directive (2002/95/EC) compliant.



## Appendix D - Reference information

---

### *Product information*

Product notices, updated drivers, support material, 24hr-online ordering:

[www.eurotech-ltd.co.uk](http://www.eurotech-ltd.co.uk)

### *PC/104 consortium*

PC/104 specifications, vendor information and available add-on products:

[www.PC/104.org](http://www.PC/104.org)

### *USB information*

Universal Serial Bus (USB) specification and product information:

[www.usb.org](http://www.usb.org)

### *SDIO card information*

SD Card Association and product information:

[www.sdcard.org](http://www.sdcard.org)

[www.sdcard.com](http://www.sdcard.com)

[www.sandisk.com/oem/manuals.asp](http://www.sandisk.com/oem/manuals.asp)

### *Intel*

Intel XScale™ PXA270 processor documentation:

[www.intel.com](http://www.intel.com)

[www.intel.com/design/embeddedpca/prodbref/302302pb.htm](http://www.intel.com/design/embeddedpca/prodbref/302302pb.htm)

### *Davicom Semiconductor Inc*

Davicom DM9000A Ethernet Controller documentation:

[www.davicom.com.tw/eng/index.htm](http://www.davicom.com.tw/eng/index.htm)

### *Exar Corporation*

Exar XR16C2850 DUART with 128 byte FIFO documentation:

[www.exar.com](http://www.exar.com)

### *Wolfson Microelectronics*

Wolfson WM9712L AC'97Codec documentation:

[www.wolfson.co.uk](http://www.wolfson.co.uk)

### *NXP Semiconductors.*

NXP PCA9535 I<sup>2</sup>C I/O expander documentation:

[www.nxp.com](http://www.nxp.com)

## Appendix E - ZEUS-FPIF details

The ZEUS-FPIF allows easy connection between the TITAN and a TFT or STN LCD flat panel display. Details of the ZEUS-FPIF are shown below:

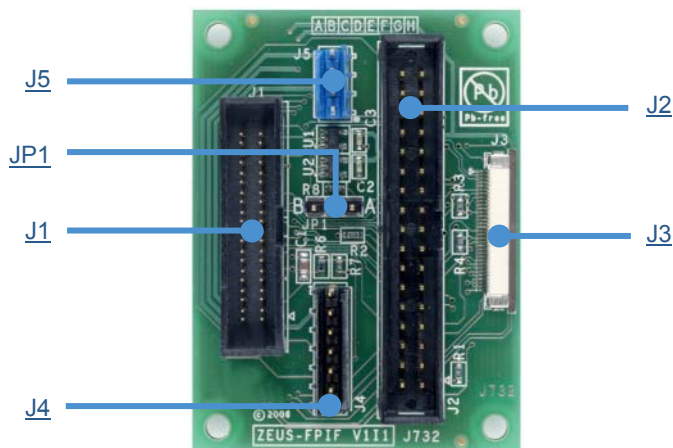

The connectors on the following pages are shown in the same orientation as the picture above.

Connector	Function
JP1	TFT clock delay selection
J1	TITAN LCD cable connector
J2	Generic LCD connector
J3	Direct connection to a NEC NL3224BC35-20 5.5inch 320x240 TFT display
J4	Backlight inverter connector
J5	STN bias connector

### JP1 – TFT clock delay selection

It has been found that some TFT displays require a delay on the clock. If this is required fit the jumper in position A; if not then fit in position B. This is illustrated below:

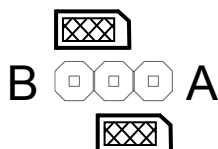



*J1 – TITAN LCD cable connector*

**Connector:** Oupiin 3215-40CSB/SN, 40-way, 1.27mm (0.05") x 2.54mm (0.1") straight-boxed header

**Mating connector:** Oupiin 1203-40GB/SN (available from Eurotech on request)

Pin	Signal name	Pin	Signal name
1	BLKEN#	2	BLKSAFE
3	GPIO 16/PWM0	4	LCDSAFE
5	NEGBIAS	6	POSBIAS
7	GND	8	GND
9	FPD1	10	FPD0
11	FPD3	12	FPD2
13	FPD5	14	FPD4
15	GND	16	GND
17	FPD7	18	FPD6
19	FPD9	20	FPD8
21	FPD11	22	FPD10
23	GND	24	GND
25	FPD13	26	FPD12
27	FPD15	28	FPD14
29	NC	30	NC
31	GND	32	GND
33	BIAS / DE	34	GND
35	FCLK / VSYNC	36	GND
37	LCLK / HSYNC	38	GND
39	PCLK / CLOCK	40	GND

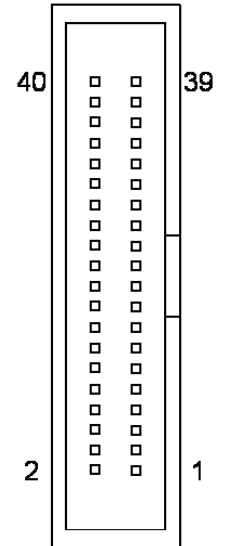

*J2 – Generic LCD connector*

**Connector:** Oupiin 3012-34GSB/SN, 34-way, 2.54mm (0.1") x 2.54mm (0.1") straight-boxed header

**Mating connector:** Fujitsu FCN-723-B034/2

**Mating connector crimps:** Fujitsu FCN-723J-AU/Q (as it is possible to connect a crimp type connector to PL2, a wide range of LCD displays can be connected with a custom cable)

Pin	Signal name	Pin	Signal name
1	GND	2	FPD 0
3	FPD 1	4	FPD 2
5	GND	6	FPD 3
7	FPD 4	8	FPD 5
9	FPD 6	10	GND
11	FPD 7	12	FPD 8
13	FPD 9	14	FPD 10
15	GND	16	GND
17	FPD 11	18	FPD 12
19	FPD 13	20	GND
21	FPD 14	22	FPD 15
23	GND	24	PCLK / CLOCK
25	GND	26	LCDSAFE
27	LCDSAFE	28	LCLK / HSYNC
29	FCLK / VSYNC	30	GND
31	BKLSAFE	32	BIAS / DE
33	NC	34	BKLEN#

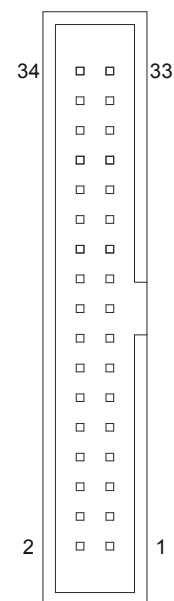

J3 – Direct connection to a NEC NL3224BC35-20 5.5inch 320x240 TFT display

Connector: Oupiin 2345-33TD2/SN

Mating cable: Eunsung 0.5x33x190xAx0.035x0.3x5x5x10x10

Pin	Signal name	Pin	Signal name
1	GND	18	FPD 10
2	PCLK	19	GND
3	LCLK (HSYNC)	20	GND
4	FCLK (VSYNC)	21	FPD 0
5	GND	22	FPD 1
6	GND	23	FPD 2
7	FPD 11	24	FPD 3
8	FPD 12	25	FPD 4
9	FPD 13	26	GND
10	FPD 14	27	LBIAS
11	FPD 15	28	LCDSAFE
12	GND	29	LCDSAFE
13	FPD 5	30	GND
14	FPD 6	31	GND
15	FPD 7	32	GND
16	FPD 8	33	GND
17	FPD 9		

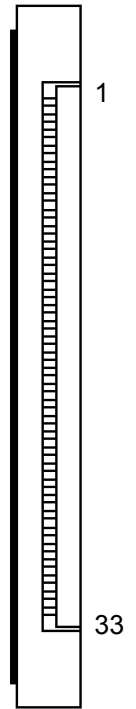

*J4 – Backlight inverter connector***Connector:** FCI 76384-407LF**Mating connector:** FCI 65240-007LF**Mating connector crimps:** FCI 76357-401LF

Pin	Signal name
1	BKLSAFE
2	BKLSAFE
3	GND
4	GND
5	BKLEN#
6	BRT_CTRL
7	GND

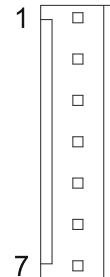
*J5 – STN bias connector***Connector:** FCI 76384-404LF**Mating connector:** FCI 65240-004LF**Mating connector crimps:** FCI 76357-401LF

Pin	Signal name
1	POSBIAS
2	GND
3	GND
4	NEGBIAS

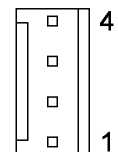

## Appendix F - ZEUS-FPIF-CRT details

The ZEUS-FPIF-CRT allows the TITAN to drive a CRT monitor or an analogue LCD flat panel. Sync on green and composite sync monitors are not supported.

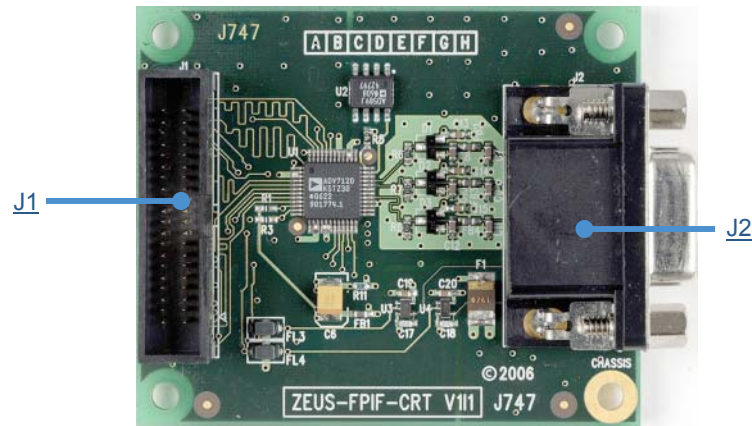

The connectors on the following pages are shown in the same orientation as the picture above.

Connector	Function
J1	TITAN LCD cable connector
J2	CRT connector

## J1 – TITAN LCD cable connector

**Connector:** Oupiin 3215-40CSB/SN, 40-way, 1.27mm (0.05") x 2.54mm (0.1") straight-boxed header

**Mating connector:** Oupiin 1203-40GB/SN (available from Eurotech on request)

Pin	Signal name	Pin	Signal name
40	GND	39	CLOCK
38	GND	37	HSYNC
36	GND	35	VSYNC
34	GND	33	DE
32	GND	31	GND
30	NC	29	NC
28	FPD14	27	FPD15
26	FPD12	25	FPD13
24	GND	23	GND
22	FPD10	21	FPD11
20	FPD8	19	FPD9
18	FPD6	17	FPD7
16	GND	15	GND
14	FPD4	13	FPD5
12	FPD2	11	FPD3
10	FPD0	9	FPD1
8	GND	7	GND
6	NC	5	NC
4	NC	3	NC
2	BKLSAFE	1	NC

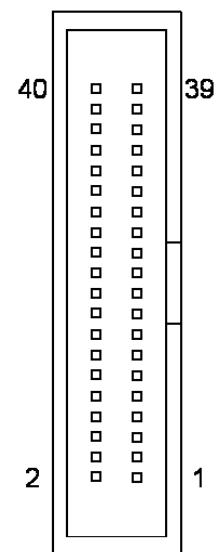

**J2 – CRT connector**

Connector: Oupiin 7916-15FA/SN, 15-way, female, high density, right-angled D-Sub.

Pin	Signal name	Pin	Signal name	Pin	Signal name
1	RED	6	RED GND	11	NC
2	GREEN	7	GREEN GND	12	NC
3	BLUE	8	BLUE GND	13	HSYNC
4	NC	9	5V_VGASAFE	14	VSYNC
5	TTL GND	10	SYNC GND	15	NC

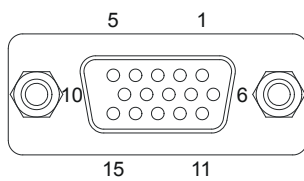

(As viewed from  
the connector pins)

## Appendix G - Ethernet Breakout details

Eurotech can provide an Ethernet breakout board with an RJ45 connector to interface to the TITAN Ethernet connectors J11 and J12. The Ethernet breakout board features brackets for panel mounting ease. It also features easy connection between the TITAN and a 10/100base-T Ethernet connection, as shown below:

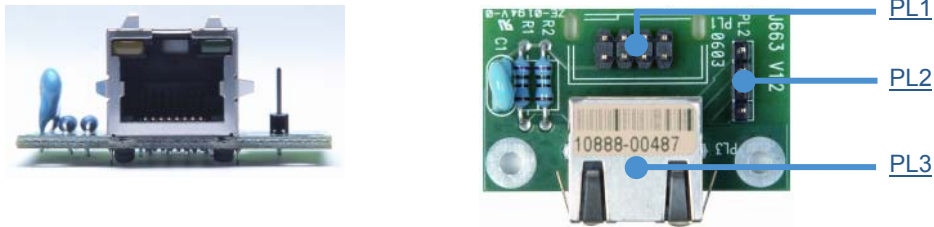

The connectors on the following pages are shown in the same orientation as the picture above.

Connector	Function
PL1	10/100BaseTX Ethernet signals
PL2	Ethernet LEDs
PL3	RJ45 connector

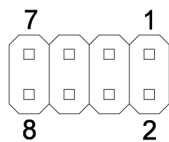

Ethernet breakout PL1

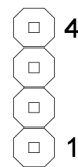

Ethernet breakout PL2

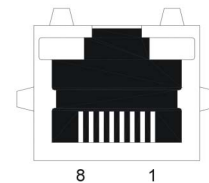

Ethernet breakout PL3



*Ethernet signal mapping between TITAN and Ethernet breakout connectors*

Ethernet breakout PL3 - RJ45		Ethernet breakout PL1 - 2x4-way header		TITAN J11 - 10/100BaseTX Ethernet connector	
Pin	Signal name	Pin	Signal name	Pin	Signal name
1	Tx+	1	Tx+	1	Tx+
2	TX-	2	TX-	2	TX-
3	RX+	3	RX+	3	RX+
4	} Bob Smith Termination	4	NC	4	NC
5		5	NC	5	NC
6	RX-	6	RX-	6	RX-
7	} Bob Smith Termination	7	NC	7	NC
8		8	LANGND	8	LANGND

*Ethernet LED signal mapping between TITAN and Ethernet breakout connectors*

Ethernet breakout PL2 - 1x 4-way header		TITAN J12 - Ethernet status LED's connector	
Pin	Signal name	Pin	Signal name
1	LINK LED+	1	3.3V
2	LINK LED-	2	LINK (Green)
3	SPEED LED+	3	3.3V
4	SPEED LED-	4	SPEED (Yellow)
		5	3.3V
		6	NC

## Appendix H - Acronyms and abbreviations

---

Amp	Amplifier
API	Application Program(ming) Interface
BTUART	Bluetooth Universal Asynchronous Receiver / Transmitter
CCCR	Core Clock Configuration Register
CODEC	Coder/Decoder
COM	Communication Port
CPLD	Complex Programmable Logic Device
CPU	Central Processing Unit (PXA270)
CMOS	Complementary Metal Oxide Semiconductor
CRT	Cathode Ray Tube
DMA	Direct Memory Access
DUART	Dual Universal Asynchronous Receiver / Transmitter
EEPROM	Electrically Erasable and Programmable Read-Only Memory
EMC	Electromagnetic Compatibility
FFUART	Full Function Universal Asynchronous Receiver / Transmitter
FIFO	First-In First-Out
FLASH	A non-volatile memory that is preserved even if the power is lost
FPIF	Flat Panel Interface
GPIO	General Purpose Input/Output
I <sup>2</sup> C	(=IIC) Intra Integrated Circuit bus
ICE	In-Circuit-Emulator
IEEE	Institute of Electrical and Electronics Engineers
IO	Input/Output
ISA	Industry Standard Architecture, Bus in the IBM-PC
JTAG	Joint Test Action Group of IEEE
kbps	kilo bits per second
LED	Light Emitting Diode
LCD	Liquid Crystal Display
LVDS	Low Voltage Differential Signalling
Mbps	mega bits per second
NA	Not Applicable
NC	No Connect
NU	Not Used
OS	Operating System
PC/104	Offers full architecture, hardware and software compatibility with the PC ISA bus, but in ultra-compact 96mm x 91mm (3.775" x 3.550") stackable modules
PCB	Printed Circuit Board
PROM	Programmable Read-Only Memory
PWM	Pulse-Width Modulation
RAM	Random Access Memory
Reg	Regulator
RTC	Real Time Clock
RX	Receive

SBC	Single Board Computer
SDIO	Secure Digital Input/Output
SDRAM	Synchronous Dynamic Random Access Memory
SRAM	Static Random Access Memory
STN	Super Twisted Nematic, technology of passive matrix liquid crystal
STUART	Standard Universal Asynchronous Receiver / Transmitter
TFT	Thin Film Transistor, a type of LCD flat-panel display screen
TX	Transmit
UART	Universal Asynchronous Receiver / Transmitter
USB	Universal Serial Bus
VGA	Video Graphics Adapter, display resolution 640 x 480 pixels
TITAN-ICE	TITAN-Industrial Compact Enclosure

## Appendix I - RoHS-6 Compliance - Materials Declaration Form



### Confirmation of Environmental Compatibility for Supplied Products

Substance	Maximum concentration
Lead	0.1% by weight in homogeneous materials
Mercury	0.1% by weight in homogeneous materials
Hexavalent chromium	0.1% by weight in homogeneous materials
Polybrominated biphenyls (PBBs)	0.1% by weight in homogeneous materials
Polybrominated diphenyl ethers (PBDEs)	0.1% by weight in homogeneous materials
Cadmium	0.01% by weight in homogeneous materials

The products covered by this certificate include:

Product Name	Eurotech Part Number
TITAN	TITAN-520-Mx-Fx

Eurotech has based its material content knowledge on a combination of information provided by third parties and auditing our suppliers and sub-contractor's operational activities and arrangements. This information is archived within the associated Technical Construction File. Eurotech has taken reasonable steps to provide representative and accurate information, though may not have conducted destructive testing or chemical analysis on incoming components and materials.

Additionally, packaging used by Eurotech for its products complies with the EU Directive 2004/12/EC in that the total concentration of the heavy metals cadmium, hexavalent chromium, lead and mercury do not exceed 100 ppm.

# Eurotech Group Worldwide Presence

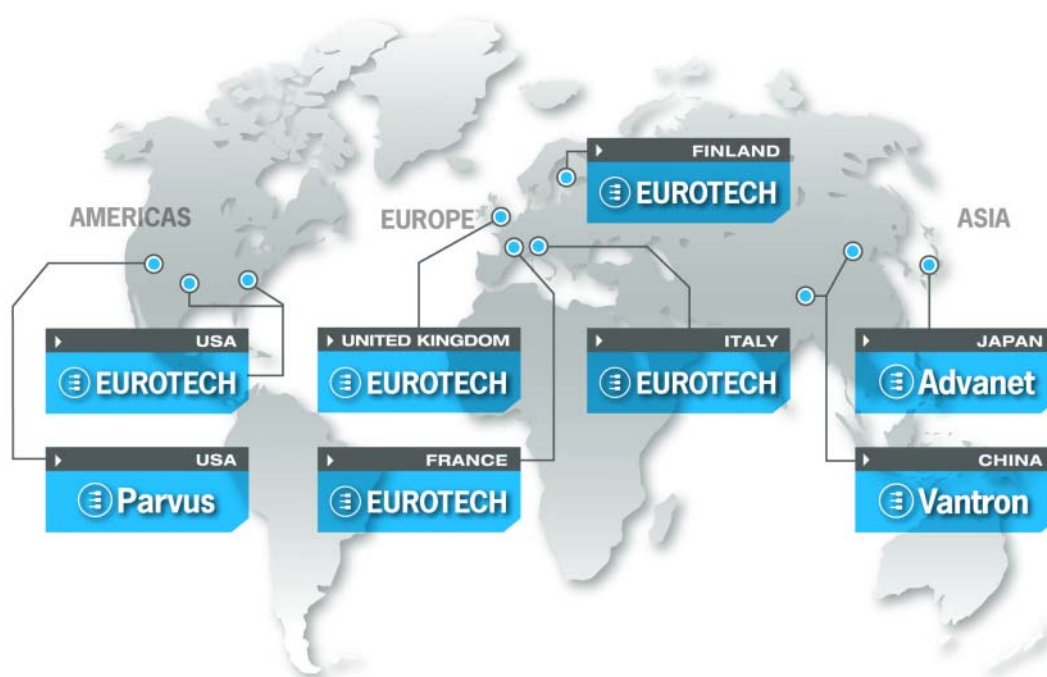

## AMERICAS

## EUROPE

## ASIA



### North America

#### EUROTECH USA

US toll free +1 800.541.2003  
 tel. +1 301.490.4007  
 fax +1 301.490.4582  
 e-mail: sales.us@eurotech.com  
 e-mail: support.us@eurotech.com  
 www.eurotech-inc.com

#### PARVUS CORPORATION

US toll-free +1 800.483.3152  
 tel. +1 801.483.1533  
 fax +1 801.483.1523  
 e-mail: sales@parvus.com  
 e-mail: tsupport@parvus.com  
 www.parvus.com

### Central & Southern Europe

#### EUROTECH Italy

tel. +39 0433.485.411  
 fax +39 0433.485.499  
 e-mail: sales-it@eurotech.com  
 e-mail: support-it@eurotech.com  
 www.eurotech.com

#### Western Europe

#### EUROTECH UK

tel. +44 (0) 1223.403410  
 fax +44 (0) 1223.410457  
 e-mail: sales.uk@eurotech.com  
 e-mail: support.uk@eurotech.com  
 www.eurotech.com

#### EUROTECH France

tel. +33 04.72.89.00.90  
 fax +33 04.78.70.08.24  
 e-mail: sales-fr@eurotech.com  
 e-mail: support-fr@eurotech.com  
 www.eurotech.com

#### Northern & Eastern Europe

#### EUROTECH Finland

tel. +358 9.477.888.0  
 fax +358 9.477.888.99  
 e-mail: sales-fi@eurotech.com  
 e-mail: support-fi@eurotech.com  
 www.eurotech.com

### Japan

#### ADVANET

tel. +81 86.245.2861  
 fax +81 86.245.2860  
 e-mail: sales@advanet.co.jp  
 www.advantech.co.jp

#### China

#### VANTRON

tel. + 86 28.85.12.39.30  
 fax +86 28.85.12.39.35  
 e-mail: sales@vantrontech.com.cn  
 e-mail: support-cn@eurotech.com  
 www.vantrontech.com.cn

