

Operator and Parts Manual

48 Rider Sweeper

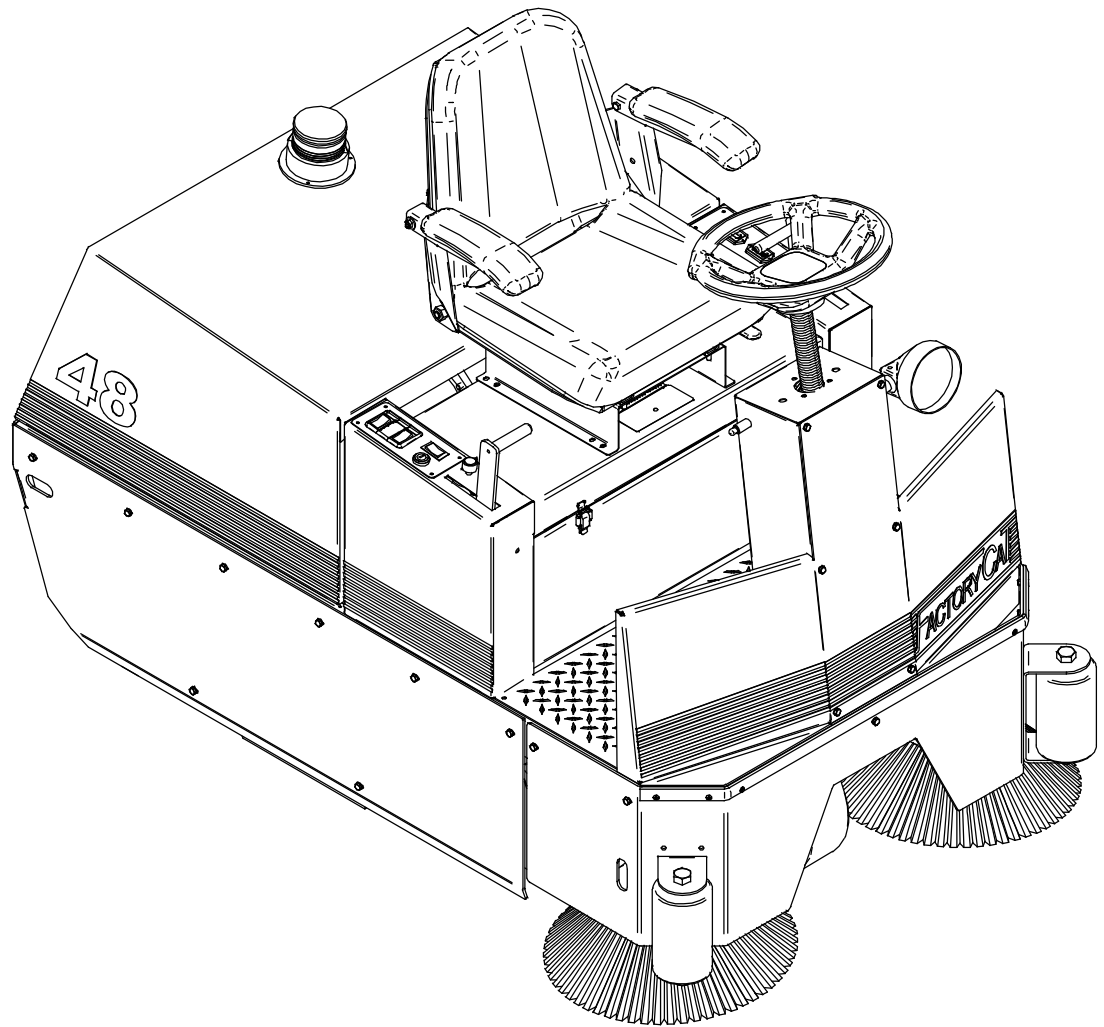

48
SERIES

R.P.S. Corporation
P.O. Box 368
Racine, Wisconsin 53401

Phone: 1-800-634-4060
Fax: 1-866-901-3335

www.factorycat.com



48 RIDER SWEEPER

THE TOMCAT 48 RIDER SWEEPER IS THE TOUGHEST COMPACT RIDER SWEEPER AVAILABLE, WITH STEEL CONSTRUCTION SO IT WILL BE WORKING YEARS FROM NOW, EVEN IN ABUSIVE ENVIRONMENT.

DEBRIS ON THE FLOOR LIKE WOOD CHIPS, CARPETING LINT, POPCORN, LEAVES, METAL PIECES, BROKEN GLASS, SAND, FINE CONCRETE DUST, AND TALCUM POWDER ARE PICKED UP IN A SINGLE PASS. THE MATERIAL IS SWEEPED UP BY THE POWERFUL MAIN BROOM, AND THROWN INTO THE RUGGED HOPPER. THE HOPPER SLIDES OUT THE SIDE OF THE MACHINE FOR EASY DISPOSAL OF DEBRIS WHEN ITS FULL.

OUR "ONE TOUCH SWEEPING" AND CENTRAL COMMAND II KEEP THE MAIN BROOM'S PRESSURE AT ONE OF FIVE SETTINGS, SO YOU WILL NOT HAVE TO ADJUST OR REVERSE IT, AND THE BROOM AUTOMATICALLY ADJUSTS TO IRREGULAR FLOORS.

THE DUST CONTROL ON THE FACTORY CAT 48 IS THE INDUSTRY LEADER. OUR EXCLUSIVE "BAGHOUSE" STYLE FILTER ENABLES THE MACHINE TO SWEEP THROUGH AN 80 POUND BAG OF CEMENT POWDER AND NOT BLOW DUST. THE FILTER'S HIGH CAPACITY DESIGN IS SIMILAR TO THE DUST COLLECTION SYSTEM ON STREETSWEEPERS, NOT VACUUM CLEANERS.

OUR 250 CFM FAN MOVES HIGH VOLUMES OF AIR, BUT AT A LOWER VELOCITY. THIS ALLOWS EXCELLENT DUST CONTROL, EVEN WITH A "DIRTY FILTER". THE LINT FROM CARPETING OR TENNIS COURTS IS EASILY CONTAINED IN THE LONG LIFE FILTER. THE FILTER IS CLEANED AT THE TOUCH OF A BUTTON.

THE FACTORY CAT 48 HAS A POWERFUL 2.0 HP SEALED DRIVE MOTOR FOR CLIMBING STEEP RAMPS, AND THE NON-MARKING TIRES PROTECT EXPENSIVE FLOORS. THE OPERATOR'S HIGH BACK SEAT INCLUDES ARMREST, IS ADJUSTABLE, AND THE PARKING BRAKE SETS AUTOMATICALLY.

THE UNIT IS BATTERY POWERED, AND WILL RUN UP TO A FULL SHIFT ON A CHARGE. THE CHARGER IS FULLY AUTOMATIC, AND PLUGS INTO 110 VOLT OUTLET.

TABLE OF CONTENTS

MACHINE INFORMATION FORM	PAGE 1	<u>PARTS BREAKDOWN ILLUSTRATION</u>	
MACHINE DELIVERY FORM	PAGE 2		
MACHINE SPECIFICATIONS	PAGE 3		
COMMON WEAR PARTS	PAGE 4	FRAME TOP	PAGE 21-22
SAFETY MESSAGES	PAGE 5	FRAME BOTTOM	PAGE 23-24
!!SAFETY PRECAUTIONS!!	PAGE 6	CENTRAL COMMAND	PAGE 25-26
MACHINE FEATURES AND CONTROLS	PAGE 7-8	DRIVE SYSTEM	PAGE 27-28
MACHINE PREPARATION	PAGE 9	MAIN BROOM AND LINKAGE	PAGE 29-30
MACHINE SETUP	PAGE 10	SIDE BROOM AND LINKAGE	PAGE 31-32
PRE-SWEEPING CHECK LIST	PAGE 11	VACUUM AND FILTER SYSTEM	PAGE 33-34
OPERATION	PAGE 12	HOPPER	PAGE 35-36
OPERATING HINTS	PAGE 12	ACCESSORIES	PAGE 37-38
CHARGING BATTERIES	PAGE 13	WIRING DIAGRAMS	PAGE 39-40
MAINTENANCE	PAGE 14		
STORING MACHINE	PAGE 14		
PREVENTATIVE MAINTENANCE RECORDS	PAGE 15-17		
TOUBLE SHOOTING	PAGE 18-19		
PARTS BREAKDOWN	PAGE 20-38		

MACHINE INFORMATION

PLEASE FILL THIS AREA OUT AT THE TIME OF INSTALLATION FOR FUTURE REFERENCE.

MODEL NUMBER: _____

SERIAL NUMBER: _____

INSTALLATION DATE: _____

INSTALLING DEALER: _____

DEALER CONTACT: _____

ADDRESS: _____

CITY, STATE, ZIP: _____

PHONE NUMBER: _____

THIS OPERATORS AND PARTS MANUAL SHOULD BE CONSIDERED A PERMANENT PART OF THE UNIT AND SHOULD REMAIN WITH THE UNIT AT ALL TIMES. THIS OPERATORS AND PARTS MANUAL COVERS ALL THE DFACTORY CAT 48 SERIES RIDER SWEEPERS. YOU MAY FIND DESCRIPTIONS AND FEATURES THAT ARE NOT ON YOUR PARTICULAR MODEL. THE INFORMATION AND SPECIFICATION INCLUDED IN THIS PUBLICATION WERE IN EFFECT AT THE TIME OF PRINTING. R.P.S. CORPORATION RESERVES THE RIGHT TO MAKE CHANGES WITHOUT NOTICE INCURRING ANY OBLIGATION.

TO REGISTER FOR WARRANTY, FAX YOUR DELIVERY FORM TODAY!



R.P.S. CORPORATION
P.O. BOX 368
RACINE, WI 53401
PHONE: 800-450-9824
FAX 866-632-6961
WWW.FACTORYCAT.COM

MACHINE DELIVERY FORM

DEALER: _____

SERIAL NUMBER: _____

LOCATION (CITY, STATE): _____

INSTALL DATE: _____

CUSTOMER: _____

HOURLY METER: _____

CONTACT: _____

INSTALLED BY: _____

ADDRESS: _____

CITY: _____ STATE _____ ZIP _____

PHONE: _____ FAX: _____

TOMCAT MODEL NUMBER: _____

OPTIONS: 1. _____

4. _____

2. _____

5. _____

3. _____

6. _____

BRUSHES: _____

BROOM: _____

SOAP: _____

BUYER'S REPRESENTATIVE HAS:

1. RECEIVED INSTRUCTION IN PROPER OPERATION OF THIS MACHINE.
2. RECEIVED OPERATOR'S MANUAL FOR THIS MACHINE.
3. BEEN MADE AWARE THAT ANY OPERATOR SHOULD READ THE MANUAL BEFORE OPERATING THIS MACHINE.

DEALER REP. PRINT: _____

SIGN: _____

CUSTOMER PRINT: _____

SIGN: _____

MODEL

48

BODY CONSTRUCTION/DIMENSIONS

CHASSIS CONSTRUCTION: 3/16" STEEL
REAR WHEELS: (2) 15" X 4"
FRONT WHEEL: 10" X 3"
SIZE (L X W X H): 64 X 37 X 50
WEIGHT (WITHOUT BATTERIES): 850 LBS.
WEIGHT (WITH BATTERIES): 1,312 LBS

SWEEPING SYSTEM

SWEEPING METHOD: DIRECT THROW
MAIN BROOM DIAMETER: 10 INCHES
MAIN BROOM LENGTH: 32 INCHES
MAIN BROOM MOTOR HORSEPOWER: 1.0 HP
MAIN BROOM SPEED: 400 RPM
MAIN BROOM SUSPENSION: TRAILING ARM
SIDE BROOM SIZE: (2) 17 INCHES
SIDE BROOM POWER: (2) 0.3 HP
SIDE BROOM SPEED: 0-95 RPM
HOPPER CAPACITY: 4.0 CUBIC FEET
HOPPER MATERIAL: STEEL (COATED)

FILTERING SYSTEM

FILTER MATERIAL: POLYMER FELT
FILTER RATING: 2.5 TO 1 MICRON (STANDARD)
1.0 TO .02 MICRON (OPTIONAL)
SIZE: 150 SQ. INCHES
VACUUM RATING: 250 CFM

BATTERY SYSTEM

BATTERY COUNT: 2 OR 4
BATTERY AH RATING: 185 AH OR 370 AH
BATTERY DESCRIPTION: 24 VOLT DEEP CYCLE
BATTERY RUN TIME: 5 TO 8 HRS.
CHARGER (AUTOMATIC): 24 AMP, 110 VOLT
40 AMP, 110 VOLT

DRIVE SYSTEM

TRANSAXLE DESCRIPTION: 2.0 HP, SEALED
SPEED CONTROL: VARIABLE 0-320 FT.
NOISE LEVEL: 70 dBA

PRODUCTIVITY

CLEANING WIDTH: 48 INCHES
CLEANING RATE/HOUR (MAX): 60,000 SQ. FT/HR
CLEANING RATE/HOUR (NORMAL): 55,000 SQ. FT/HR

WARRANTY

PARTS: 3 YEARS
LABOR: 1 YEAR

COMMON WEAR PARTS

ITEM

MODEL 48

MAIN BROOM

UNION	8-401 U
NYLON	8-401 N
POLY	8-401
CARPET	8-401NN
WIRE	8-401W
UNION STEEL	8-401US
POLY AND STEEL	8-401S

SIDE BROOM

QUANTITY REQUIRED (2) 17 INCH BROOMS

POLY	4-402
NYLON	4-402 N
POLY AND STEEL	4-402 S

FLAPS KITS

8-570

HOPPER FLAP

1/8 INCH	8-571 H
1/16 INCH	8-571
1/32 INCH	8-571 L

WE RECOMMEND YOU USE OUR BROOMS. THEY ARE MADE FOR YOUR MACHINE. OUR BRAND OF BROOMS HAS A PRECISION PLASTIC CORE THAT IS CAREFULLY BALANCED AND HAS MACHINED INSERT POINTS SO THE BROOM FITS TIGHTLY ON THE MACHINE'S HUBS. BROOMS MADE BY "WILL FIT" COPANIES TO FIT OUR MACHINES ARE OFTEN MADE WITH ROUGH DRAIN-PIPE CORES. THEY OFTEN BOUNCE EVEN WHEN NEW. BOUNCING BROOMS DO NOT SWEEP.

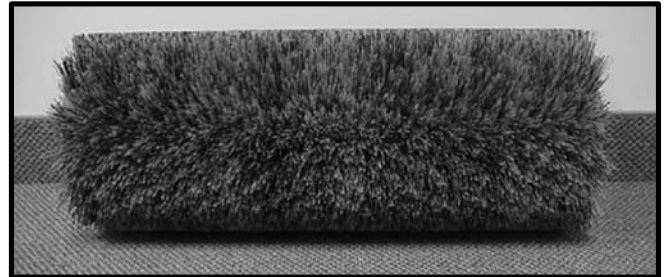

*DOUBLE FIBER VEE-BROOM.
USED MORE FOR CARPETED FLOORS*

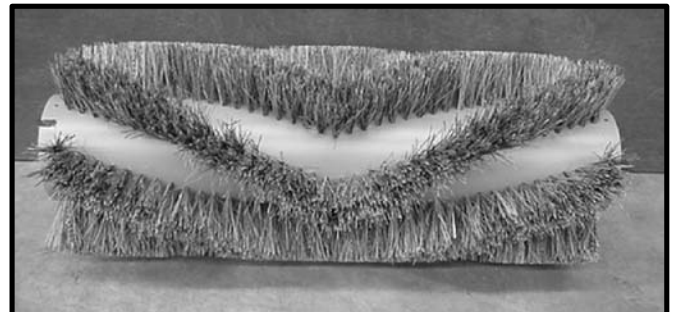

VEE-BROOM. PREFERRED STYLE

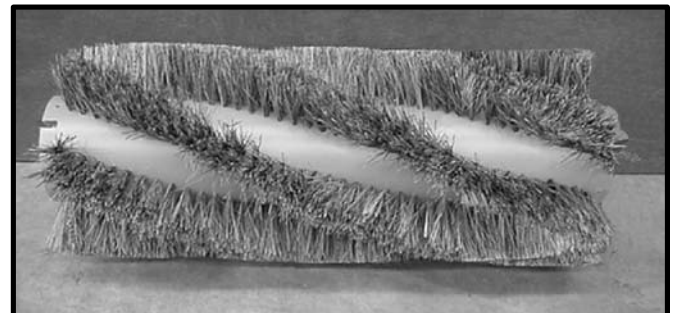

*SPIRAL-BROOM. DOES NOT SWEEP
AS WELL AS VEE BROOM.*

KIT INCLUDES: (1) HOPPER FLAP, (1) RIGHT SIDE, (1) LEFT SIDE AND (1) REAR FLAP

NOTE: CECK YOUR HOPPER FLAP FOR THCKNESS. THE THIN (1/32 INCH) FLAP WORKS BEST ON LIGHT DEBRIS, BUT IT CAN BE MORE EASILY DAMAGED. THE STANDARD SIZES ARE (1/16 INSH)

SAFETY MESSAGES

YOUR SAFETY, AND THE SAFETY OF OTHERS, IS VERY IMPORTANT, AND OPERATING THIS UNIT SAFELY IS AN IMPORTANT RESPONSIBILITY.

TO HELP YOU MAKE INFORMED DECISIONS ABOUT SAFETY, WE HAVE PROVIDED OPERATING PROCEDURES AND OTHER SAFETY INFORMATION IN THE MANUAL. THIS INFORMATION INFORMS YOU OF POTENTIAL HAZARDS THAT COULD HURT YOU OR OTHERS.

IT IS NOT PRACTICAL OR POSSIBLE TO WARN YOU OF ALL THE HAZARDS ASSOCIATED WITH OPERATING THIS UNIT. YOU MUST USE YOUR OWN GOOD JUDGEMENT.

THIS IS INTENDED FOR COMMERCIAL USE. IT IS DESIGNED TO BE USED ON HARD FLOORS IN AN INDOOR ENVIRONMENT, WITH THE RECOMMENDED BRUSHES.

1. DO NOT OPERATE UNIT:

UNLESS TRAINED AND AUTHORIZED.
UNLESS OPERATOR MANUAL IS READ AND UNDERSTOOD.
IF UNIT IS NOT PROPER CONDITION.

2. WHEN OPERATING UNIT:

KEEP HANDS AND FEET AWAY FROM REVOLVING SIDE BROOMS.
DO NOT OPERATE MACHINE WHERE FLAMMABLE LIQUIDS ARE PRESENT.
USE EXTREME CAUTION WHEN MANUEVERING.

3. BEFORE LEAVING:

MAKE SURE MACHINE IS TURNED OFF.
STOP ON LEVEL SURFACES.
DISCONNECT BATTERIES.

4. BEFORE SERVICING:

STOP ON LEVEL SURFACE, AND SECURE MACHINE.
DISCONNECT BATTERIES.

!! SAFETY PRECAUTIONS!!

WARNING: HAZARDOUS VOLTAGE. SHOCK, BURNS OR ELECTROCUTION CAN RESULT. ALWAYS DISCONNECT THE BATTERIES BEFORE SERVICING MACHINE.

WARNING: BATTERIES EMIT HYDROGEN GASES, EXPLOSION OR FIRE CAN RESULT. KEEP SPARKS AND OPEN FLAMES AWAY.

WARNING: CHARGE UNIT IN A WELL VENTILATED AREA, AND KEEP BATTERY COMPARTMENT OPEN WHEN CHARGING. EXPLOSION OR FIRE COULD RESULT.

WARNING: BATTERY ACID CAN CAUSE BURNS. WEAR PROTECTIVE EYE WEAR AND GLOVES WHEN SERVICING BATTERIES.

WARNING: DO NOT STORE OUTDOORS OR PRESSURE WASH. PREVENT ELECTRONIC COMPONENTS FROM GETTING WET.

WARNING: THE USE OF PARTS AND SOLUTIONS OTHER THAN RECOMMENDED BY THE MANUFACTURER MAY CAUSE DAMAGE OR ENDANGER PEOPLE.

WARNING: DRESS SAFELY. DO NOT WEAR RINGS OR METAL WRIST WATCHES WHILE WORKING ON THIS MACHINE. THEY CAN CAUSE AN ELECTRICAL SHORT, WHICH, CAN CAUSE SERIOUS BURNS. DO NOT WORK ON THIS MACHINE WHILE WEARING A TIE, SCARF OR OTHER LOOSE, DANGLING NECKWARE OR CLOTHING. THESE LOOSE ITEMS CAN TANGLE IN THE ROTATING PARTS AND CAUSE SERIOUS INJURY OR EVEN DEATH.

WARNING: DO NOT USE THE MACHINE AS A STEP LADDER OR CHAIR.

WARNING: ONLY OPERATE THIS MACHINE FROM THE OPERATOR'S SEAT. IT WAS NOT DESIGNED TO CARRY PASSENGERS.

WARNING: DO NOT OPERATE THIS MACHINE ON RAMPS OR UNEVEN SURFACES. WHEN CLIMBING A RAMP, ALWAYS DRIVE THE MACHINE IN FORWARD STRAIGHT UP OR DOWN THE RAMP. NEVER DRIVE ACROSS THE INCLINE. DO NOT BACK DOWN OR TURN ON RAMPS!

WARNING: ALWAYS USE THE CHARGER PROVIDED BY THE MAUFACTURER TO CHARGE THE MACHINE. IT IS AN AUTOMATIC CHARGER, SPECIFICALLY DESIGNED TO CHARGE AT THE APPROPRIATE RATE. IF YOU MUST USE A DIFFERENT CHARGER, DISCONNECT THE BATTERIES BEFORE CHARGING. THIS WILL PRVENT DAMAGE TO THE ELECTRONIC SPEED CONTROLLER.

WARNING: UNDERSTAND THE DYNAMIC BRAKING SYSTEM BEFORE YOU OPERATE THE MACHINE ON RAMPS. MACHINE DOES NOT COAST. RELEASING THE FOOTPEDAL WILL AUTOMATICALLY APPLY BRAKING FORCE, AND STOP THE MACHINE.

WARNING: DO NOT PARK THE MACHINE ON RAMPS OR SLOPES. THE MACHINE HAS A PARKING BRAKE, BUT IT IS RECOMMENDED THAT IS ALWAYS BE PARKED ON LEVEL GROUND.

WARNING: DO NOT OPERATE THE MACHINE IF ANY PARTS HAVE BEEN REMOVED OR DAMAGED.

WARNING: DO NOT REMOVE, PAINT OVER, OR DESTROY WARNING DECALS. IF WARNING DECALS BECOME DAMAGED, THEY MUST BE REPLACED.

WARNING: DO NOT OPERATE MACHINE IN UNSAFE CONDITION. IF THE MACHINE IS IN NEED OF REPAIR OR IS IN ANY WAY UNSAFE TO OPERATE, THE MATTER SHOULD BE REPORTED IMMEDIATELY TO THE SHIFT SUPERVISOR. DO NOT OPERATE THE MACHINE UNTIL IT IS RETURNED TO PROPER OPERATING CONDITION.

WARNING: THIS MACHINE MUST ONLY BE OPERATED BY TRAINED OPERATOR. AS PART OF HIS OR HER TRAINING, THEY MUST READ THIS MANUAL THOROUGHLY. IF EXTRA COPIES ARE NEEDED, CONTACT YOUR LOCAL DEALER.

WARNING: ALWAYS TURN OFF THE MACHINE, BEFORE LEAVING IT UNATTENDED.

WARNING: DO NOT SWEEP OVER ELECTRICAL FLOOR OUTLETS. MAY RESULTS IN SERIOUS INJURY.

MACHINE CONTROLS AND FEATURES

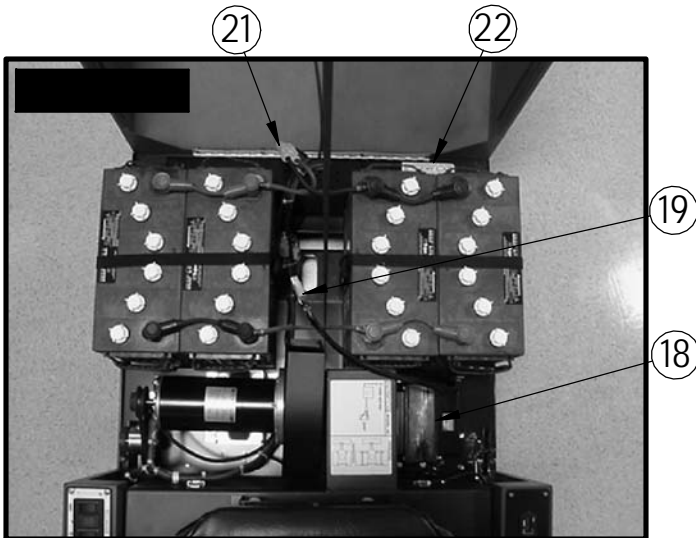
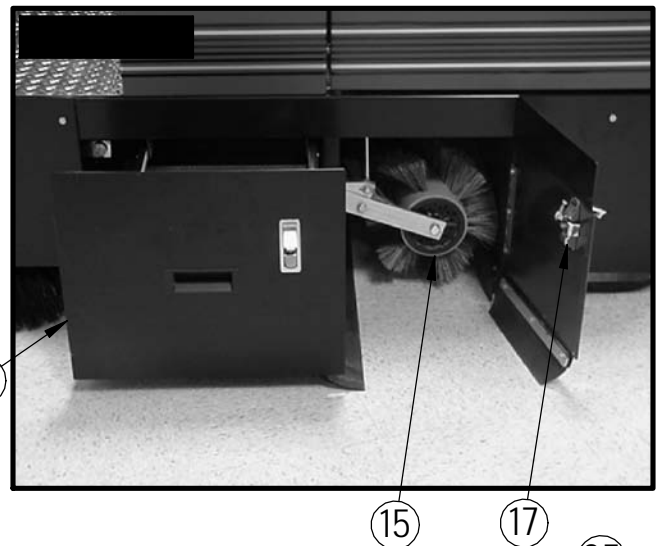
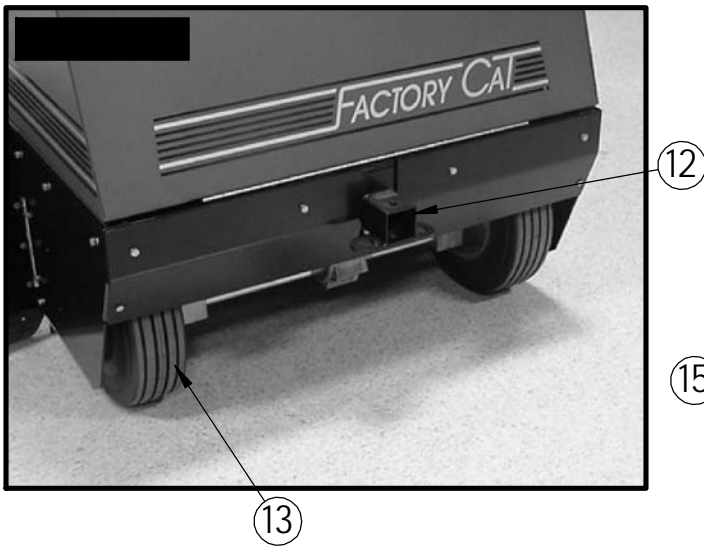
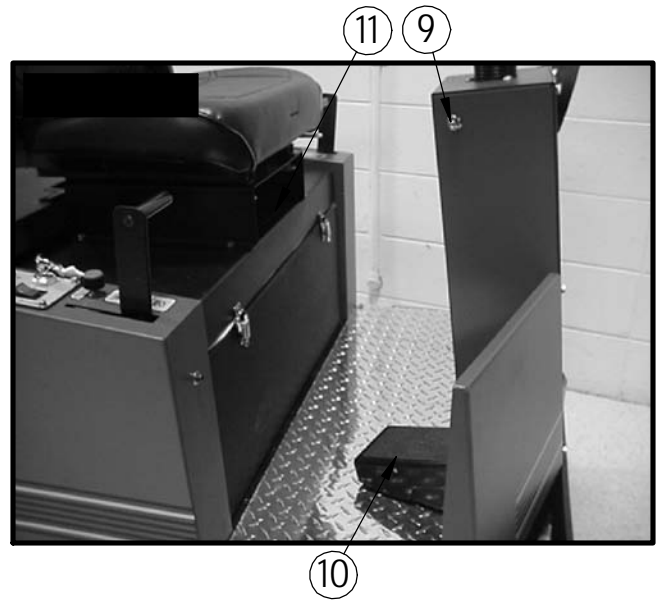
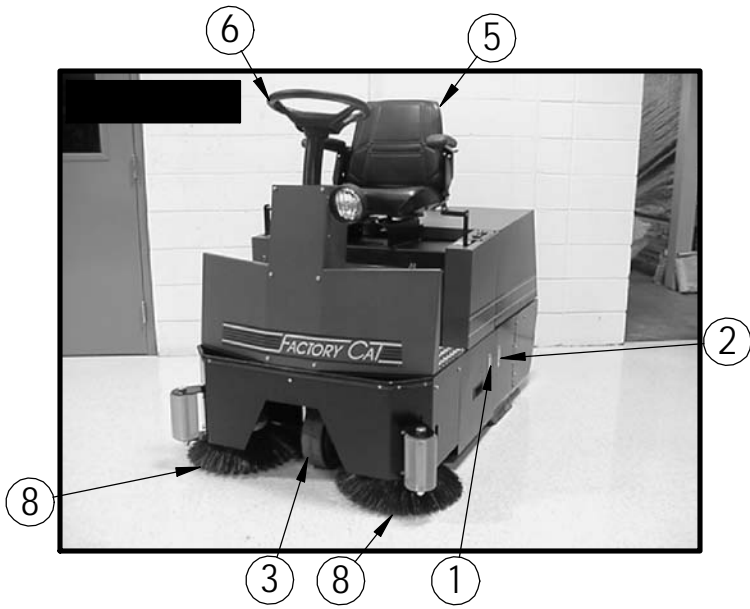

CONTROLS AND FUNCTIONS

SEE FIG. (1-7) ON PAGE 7

FIGURE 1.

1. HOPPER LATCH: KEEPS HOPPER IN PLACE.
2. ACCESS PANEL LATCH: GIVES YOU QUICK ACCESS TO MAIN BROOM.
3. FRONT WHEEL: STEERS MACHINE.
4. HEADLIGHT: HELPS YOU SEE IN LOW LIGHT AREAS AND TO WORN ONCOMING TRAFFIC..
5. SEAT: ADJUSTABLE SEAT FOR OPERATOR COMFORT AND EASE OF ENTRY.
6. STEERING WHEEL: USED TO STEER THE MACHINE.
7. STROBE LIGHT: SAFETY LIGHT.
8. SIDE BROOMS: HELPS CLEAN AGAINST WALLS AND OBJECTS.

FIGURE 2.

9. HORN BUTTON: SOUNDS HORN.
10. FOOT PEDAL: MAKES MACHINE GO.
11. WET SWEEP BY-PASS: YOU SWEEP OVER WATER WITHOUT SUCKING THE WATER UP INTO THE FILTER.

FIGURE 3.

12. HITCH RECEIVER: ALLOWS YOU TO HOOK UP AND TOW R.P.S. SUPPLIED ACCESSORIES ONLY.
13. REAR TIRES: PROVIDE POWER THROUGH TRANSAXLE TO DRIVE MACHINE.
14. AUX. POWER PLUG: ALLOWS YOU TO HOOK UP EXTERNAL R.P.S. SUPPLIED ACCESSORIES ONLY.

FIGURE 4.

15. HOPPER: HOLDS DEBRIS AND IS REMOVABLE FOR EASY DISPOSAL.
16. MAIN BROOM: SWEEPS DEBRIS INTO HOPPER.
17. BROOM ACCESS PANEL: PROVIDES EASY ACCESS TO MAIN BROOM.

FIGURE 5.

18. CHARGER: RECHARGES BATTERIES FOR FUTURE USE.
19. CHARGER HOOK-UP: PLUGS INTO PACK TO CHARGE UNIT.
20. BATTERIES: PROVIDE POWER TO RUN MACHINE.
21. BATTERY DISCONNECT: BREAKS POWER FROM BATTERIES TO MACHINE.
22. CENTRAL COMMAND: BRAIN BOX OF THE MACHINE.
23. BACK UP ALARM: SOUNDS WHEN MACHINE IS IN REVERSE.
24. MAIN BROOM/FAN MOTOR: PROVIDES POWER TO MAIN BROOM AND VACCUM SYSTEM.

FIGURE 6.

25. MAIN BROOM HANDLE: LIFTS AND LOWERS MAIN BROOM.
26. HOUR METER: COUNTS HOW MANY HOURS THE MACHINE HAS BEEN RUN.
27. BATTERY CONDITION METER: SHOWS THE CHARGE LEFT ON THE BATTERIES.

FIGURE 7.

28. SIDE BROOM HANDLE: LIFTS AND LOWERS SIDE BROOMS.
29. SIDE BROOM RHEOSTAT: ADJUSTS ROTATION SPEED OF SIDE BROOMS.
30. KEY SWITCH: TURNS POWER TO MACHINE ON AND OFF.
31. FORWARD/REVERSE SWITCH: SWITCHES THE DIRECTION OF THE MACHINE FORWARD AND BACKWARDS.
32. SIDE BROOM ON/OFF SWITCH: TURNS SIDE BROOMS ON AND OFF.
33. FILTER SHAKER SWITCH: SHAKES DEBRIS FROM FILTER AND DROPS THEM INTO HOPPER.
34. POWER INDICATOR LIGHT: TELLS IF THE MACHINE IS TURNED ON.
35. SIDE BROOM ADJUSTMENT: ADJUSTS HEIGHT OF SIDE BROOMS.

MACHINE PREP

UNCREATING MACHINE

CAREFULLY CHECK THE CRATE FOR ANY SIGNS OF DAMAGE. BATTERIES ARE IN THE UNIT.

TO UNCREATE THE MACHINE, REMOVE BANDING FROM AROUND THE CRATE. TAKE OFF THE TOP AND SIDES AND DISPOSE OF PROPERLY. REMOVE BANDING FROM MACHINE. REMOVE THE CHOCKS AROUND THE DRIVE WHEELS. FOLD DOWN RAMP, AND ROLL MACHINE OFF OF THE BASE. NOTIFY THE CARRIER IMMEDIATELY IF CONCEALED DAMAGE IS DISCOVERED.

CONNECTING BATTERIES

YOUR MACHINE IS EQUIPPED WITH (TWO) OR (FOUR) 12 VOLT, DEEP CYCLE, 185 AMP HOURS BATTERIES, WHICH FORM A 24 VOLT SYSTEM.

1. TURN ALL SWITCHES TO THE OFF POSITION AND REMOVE KEY.
2. OPEN REAR HOOD TO ACCESS THE BATTERY COMPARTMENT.
3. BOTH OF THE TWO BATTERY CABLES ARE CONNECTED TO THE BATTERIES. LOCATE THE GREY 50 CONNECTOR AND CONNECT THE TWO. (SEE FIGURE 8.)
4. TURN ON MAIN POWER SWITCH AND CHECK THE BATTERY CONDITION METER TO ENSURE CORRECT INSTALLATION. CHARGE BATTERIES IF NEEDED. (SEE: BATTERY CHARGING)



ATTACHING SIDE BROOMS

1. LOWER THE SIDE BROOM LINKAGE BY PULLING BACK ON THE LEVER AND THEN SLIDING THE LEVER ALL THE WAY TO THE REAR. (SEE FIGURE 9.)



2. REMOVE THE SIDE BROOMS FROM THE SHIPPING BOX.
3. INSTALL THE SIDE BROOMS ONTO THE MOTOR SHAFT, BY SLIDING THEM UPWARDS. LINE UP THE HOLES AND INSTALL THE CLEVIS PIN WITH SAETY CLIP (SEE FIGURE 10.)
4. YOU MAY NEED TO ADJUST THE SIDE BROOM HEIGHT, BY USING THE ADJUSTMENT SCREW.



MACHINE SETUP

REPLACING MAIN BROOM

1. TURN THE MACHINE OFF. USE A 9/16 INCH WRENCH TO REMOVE THE 3/8-16 HCS SCREW AND REMOVE THE IDLER ARM. (SEE FIGURE 11.)



2. THE MAIN BROOM SHOULD SLIDE OUT THE SIDE OF THE MACHINE EASILY. (SEE FIGURE 12.)



3. SLIDE THE NEW BROOM IN. WHEN YOU GET THE BRUSH ON THE DRIVER SPIN IT WITH YOUR HAND UNTIL YOU FEEL IT CATCH ON THE DRIVER AND THEN PRESS IN COMPLETELY ON. (SEE FIGURE 13.)



4. WHEN THE MAIN BROOM COMPLETELY INSTALLED REPLACE THE IDLER ARM AND THE FASTENERS. THE ARM SHOULD GO ON EASILY, AND METAL TO METAL. IF THERE IS ANY GAPS LEFT BEFORE TIGHTENING, IT HAS NOT BEEN INSTALLED PROPERLY. (SEE FIGURE 14.)

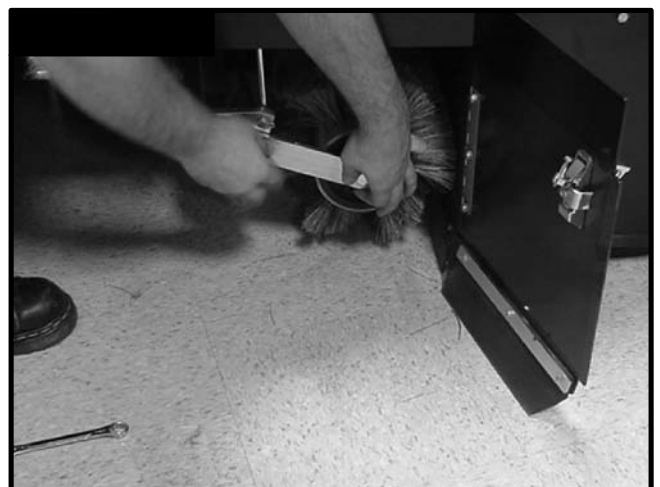

WARNING: IF THE BROOM IS NOT FULLY ENGAGED WITH THE DRIVERS, THE BRUSHES WILL BE DAMAGED. DO NOT FORCE THE IDLER ARM BACK ON. THIS USUALLY INDICATES IMPROPER INSTALLATION

NOTE: SELECT THE BROOM FIBER THAT BEST MEETS YOUR CLEANING APPLICATION CONSULT YOUR LOCAL DEALER FOR ASSISTANCE. (SEE BRUSH TYPES ON PAGE 4.)

PRE- SWEEPING CHECK LIST

READ AND UNDERSTAND SAFETY INSTRUCTIONS ON PAGE 5 AND 6
BEFORE OPERATING THIS MACHINE

1. CHECK BATTERY CONDITION ON BATTERY CONDITION METER. MAKE SURE BATTERIES ARE FULLY CHARGED BEFORE USING. (SEE FIGURE 15.)



2. CHECK CONDITION OF MAIN BROOM AND MAKE SURE IT IS SECURELY IN PLACE.
3. REMOVE ALL STRING BANDING, OR ANYTHING WOUND AROUND THE IDLER PULLEY AND BEARING. (SEE FIGURE 16.)



4. CHECK CONDITION OF SIDE BROOMS AND MAKE SURE THEY LIFT AND LOWER CORRECTLY.
5. CHECK THE SIDE BROOMS TO SEE IF THEY ARE AT THE CORRECT SETTING FOR SWEEPING. (SEE FIGURE 17.)



6. CLEAN THE FILTER BY PRESSING THE SHAKER SWITCH FOR ABOUT 10 SECONDS. (SEE FIGURE 18.)



7. PRESS THE HOPPER LATCH, ON THE LEFT SIDE OF THE MACHINE. REMOVE THE HOPPER FROM THE MACHINE. (SEE FIGURE 19.)



8. EMPTY THE HOPPER INTO A TRASH RECEPTICLE.
9. INSTALL THE HOPPER BACK INTO THE MACHINE AND DEPRESS THE HOPPER LATCH. (SEE FIGURE 20.)

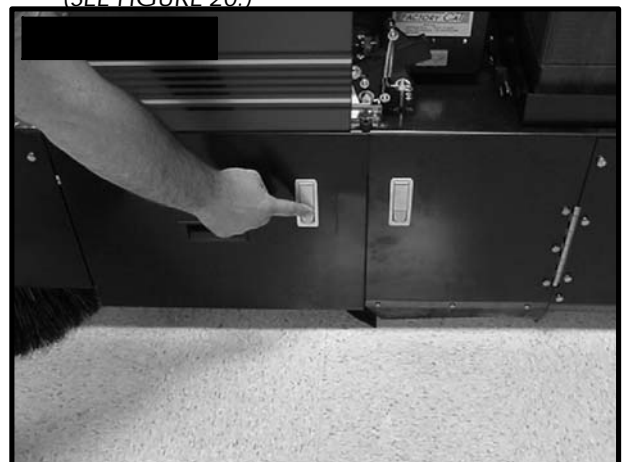

OPERATION

ONE PASS SWEEPING

1. TURN MACHINE ON WITH THE KEYSWITCH.
2. TURN ON THE FILTER BEATER FOR ABOUT SECONDS TO CLEAR THE FILTER.



3. LOWER MAIN BROOM TO THE FLOOR, PULLING BACK ON LEVER AND THEN SLIDING THE LEVER ALL THE WAY TO THE REAR.



4. TURN ON DUST CONTROL SYSTEM AGAIN USE THE TOP HALF (1) OF THE FAN SWITCH.
5. LOWER SIDE BROOMS TO THE FLOOR.



6. BEGIN SWEEPING BY DEPRESSING THE FOOT PEDAL SLOWLY AND THEN TO THE SPEED REQUIRED.
7. ONCE THE MAIN BROOM BEGINS TO MOVE, CHECK THE PRESSURE GAUGE.
8. TO OPERATE MACHINE IN REVERSE, SIMPLY SWITCH THE REVERSE SWITCH TO THE REVERSE POSITION.
9. TO STOP THE MACHINE, LET OFF OF THE FOOT PEDAL, AND THE MACHINE WILL STOP AUTOMATICALLY.

OPERATING HINTS

1. OBSERVE THE SPEED OF THE MACHINE AND ADJUST TO THE DESIRED RATE. TO INCREASE THE SPEED, DEPRESS THE FOOTPEDAL MORE. TO STOP THE MACHINE, LET OFF THE FOOTPEDAL AND THE BRAKE WILL AUTOMATICALLY BE APPLIED.
2. KEEP AN EYE ON THE VACUUM MOTOR TO MAKE SURE THERE IS NO DUST BLOW-THRU. IF DUST BEGINS TO DEVELOP, THE FILTER SHOULD BE CLEANED. PRESS THE FILTER SHAKER SWITCH TO CLEAN THE FILTER.
3. ALWAYS OPERATE AT LOWER SPEEDS WHEN SWEEPING AROUND WALLS AND OBJECTS. YOU SHOULD REDUCE THE SPEED, TO MAINTAIN CONTROL WHEN TURNING.
4. IF THE MACHINE STARTS TO TRAIL, STOP AND EMPTY THE HOPPER. IF THE TRAILING DEBRIS CONTINUES, YOU MAY NEED TO REPLACE THE SKIRTS THAT SURROUND THE SWEEPING CHAMBER.
5. CHANGE THE BRUSHES WHEN WORN TO A FIBER LENGTH OF 1 INCH.
6. STAY CLEAR OF OBJECTS PROTRUDING FROM THE FLOOR, SUCH AS SOCKETS, AND PIPES, FOR THEY CAN DAMAGE THE LOWER SKIRTS.
7. YOU SHOULD TRY TO AVOID WATER, OIL AND, OTHER LIQUIDS SPILLED ON THE FLOOR. BE SURE TO USE THE WET SWEEP BY-PASS WHEN SMALL AMOUNTS OF MOISTURE ARE ENCOUNTERED.
8. ALWAYS KEEP AN EYE ON YOUR GAUGES. THEY ARE THERE TO HELP YOU CLEAN MORE EFFICIENTLY, BY LETTING YOU KNOW THE STATUS OF THAT PARTICULAR SYSTEM AT A GLANCE. IF YOUR BATTERY GAUGE IS READING LOW, YOU MUST STOP IMMEDIATELY, AND RECHARGE. RUNNING THE BATTERY DEAD, WILL RESULT IN DAMAGE TO THE BATTERIES.
9. KEEPING THE EXTERIOR APPEARANCE OF THE MACHINE IN GOOD CONDITION, WILL GENERALLY ENCOURAGE OTHERS TO TREAT THE MACHINE WITH MORE CARE.
10. WHEN YOU ARE READY TO STOP, PICK UP THE BROOMS, DRIVE THE MACHINE BACK TO THE CHARGING AREA AND BE SURE TO TURN OFF THE POWER SWITCH. BE SURE TO EMPTY THE HOPPER AND CLEAN THE FILTER BEFORE STORING.

BATTERY CHARGING

CAUTION: THE FOLLOWING INSTRUCTIONS ARE INTENDED FOR THE 24V CHARGER SUPPLIED WITH THE MACHINE. DO NOT USE ANY OTHER CHARGER WITH THIS MACHINE.

CHARGER SPECIFICATIONS

OUTPUT VOLTAGE OF 24 VOLTS.

OUTPUT CURRENT OF 25 AMPS MAX. (2 BATTERY SYSTEM)

OUTPUT CURRENT OF 40 AMPS MAX. (4 BATTERY SYSTEM)

INPUT VOLTAGE OF 110 VOLTS.

AUTOMATIC SHUT OFF CIRCUIT.

MADE FOR DEEP CYCLE BATTERIES.

DANGER: ALWAYS CHARGE BATTERIES IN A WELL VENTILATED AREA. BATTERIES EMIT HYDROGEN GAS. EXPLOSION OR FIRE CAN RESULT. KEEP SPARKS AND FLAME AWAY. SHIELD EYES WHEN SERVICING BATTERIES AND AVOID CONTACT WITH BATTERY ACID. LEAVE BATTERY HOOD OPEN!

1. TRANSPORT MACHINE TO A WELL VENTILATED AREA FOR CHARGING.
2. TURN THE MACHINE OFF.
3. HINGE OPEN HOOD TO EXPOSE THE BATTERIES. (SEE FIG. 24)
(CAUTION ALWAYS WEAR EYE PROTECTION WHEN BATTERIES ARE EXPOSED)

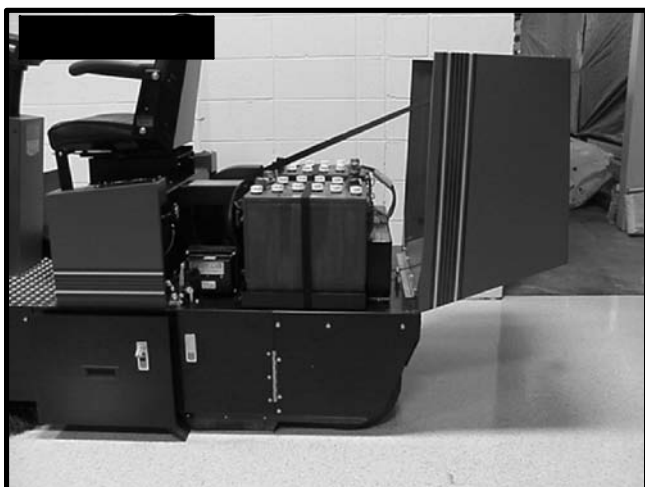

4. CHECK THE WATER LEVEL IN EACH BATTERY. DO NOT CHARGE THE MACHINE UNLESS THE WATER IS SLIGHTLY HIGHER THAN THE PLATES. IF NEEDED, ADD ENOUGH *DISTILLED* WATER TO JUST SLIGHTLY COVER THE PLATES. DO NOT OVER FILL. BATTERIES CAN OVERFLOW DURING CHARGING. REPLACE CAPS BEFORE CHARGING.
5. PLUG THE CHARGER POWER CORD INTO A GROUNDED WALL OUTLET.
6. THE GREEN LIGHT ON THE CHARGER WILL COME ON WHEN THE CHARGER IS WORKING. (SEE FIGURE 25)



7. THE CHARGER WILL AUTOMATICALLY BEGIN CHARGING, AND AUTOMATICALLY SHUT OFF WHEN FULLY CHARGED. THE GREEN LIGHT WILL GO OUT WHEN THE CHARGER SHUTS OFF.
8. AFTER THE CHARGER HAS TURNED OFF, DISCONNECT THE CHARGER FROM THE WALL OUTLET.
9. RECHECK THE CELL LEVEL AFTER CHARGING. IF NEEDED, ADD *DISTILLED* WATER UP TO THE CORRECT LEVEL. BE CERTAIN TO REPLACE THE CAPS SECURELY AND TO WIPE OFF THE TOP OF THE BATTERIES WITH A CLEAN CLOTH.

MAINTENANCE

DAILY MAINTENANCE

1. CLEAN THE FILTER WITH THE SHAKER SWITCH FOR 20 SECONDS.
2. REMOVE AND CLEAN DEBRIS FROM THE HOPPER AND RINCE OUT IF NECESSARY.
3. CHARGE THE MACHINE WITH THE HOOD OPEN TO ALLOW THE BATTERIES TO VENTILATE PROPERLY.
4. REPORT ANY DAMAGE TO A SUPERVISOR.
5. WIPE DOWN MACHINE IF NEEDED. USE A NONABRASIVE, NON SOLVENT CLEANER, OR A CLEAN DAMP CLOTH.
6. RECHARGE THE BATTERIES IF NEEDED.

WEEKLY MAINTENANCE

1. CHECK BATTERY WATER LEVEL.
2. CHECK CONDITION OF ALL THREE TIRES.
3. CHECK CONDITION OF DUST CURTAINS ON SHROUD.
4. CHECK CONDITION OF DUST CURTAIN ON WALLS.
5. CHECK TO SEE IF VACCUM EXHAUST IS CLEAR.

MONTHLY MAINTENANCE

1. LUBRICATE FRONT CASTERS WITH A WATERPROOF GREASE.
2. CHECK MACHINE FOR VACUUM LEAKS AND LOOSE NUTS AND BOLTS

YEARLY MAINTENANCE

1. CALL YOUR LOCAL DEALER FOR YEARLY MAINTENANCE.

STORING MACHINE

1. BE SURE TO CLEAN FILTER
2. EMPTY HOPPER INTO TRASH RECEPTACLE.
3. RAISE MAIN BROOM AND SIDE BROOMS.

NOTE: IF YOU LEAVE BROOMS DOWN ON FLOOR FOR EXTENDED PERIOD WHILE MACHINE IS NOT IN USE THEY WILL DEVELOPE FLAT SPOTS. THIS WILL CAUSE " BROOM BOUNCE" AND BAD SWEEPING.

PREVENTATIVE MAINTENANCE RECORDS

USE THIS FORM TO MAKE COPIES FOR YOUR INTERNAL RECORDS

PREVENTATIVE MAINTENANCE

CHECKED

NOTE

CHECK BROOM FOR DEBRIS
SHAKE FILTER WITH SWITCH
EMPTY HOPPER
CHECK BROOM FIBER LENGTH
CHECK SIDE BROOM ADJUSTMENT
CHECK FLOOR SEALS
CHECK BELTS FOR WEAR
CHECK BATTERY WATER LEVEL
CHECK BATTERY VOLTAGE
CHECK CHARGER CONDITION
CHECK MACHINE PERFORMANCE
SWEEPING POWER
VACUUM POWER
CONTROLS
GAUGES AND CONTROLS
CHECK WHEEL TRACKTION
GREASE FRONT WHEEL
SWEEPS AROUND TURNS

OTHER: _____

OTHER: _____

PAST HOUR METER READING:

CURRENT HOUR METER READING:

AVERAGE WEEKLY USAGE:

TECHNICIAN PRINT: _____

TECHNICIAN SIGNATURE: _____

DATE: _____

MANAGER SIGNATURE: _____

DATE: _____

PREVENTATIVE MAINTENANCE RECORDS

USE THIS FORM TO MAKE COPIES FOR YOUR INTERNAL RECORDS

PREVENTATIVE MAINTENANCE

CHECKED

NOTE

CHECK BROOM FOR DEBRIS
SHAKE FILTER WITH SWITCH
EMPTY HOPPER
CHECK BROOM FIBER LENGTH
CHECK SIDE BROOM ADJUSTMENT
CHECK FLOOR SEALS
CHECK BELTS FOR WEAR
CHECK BATTERY WATER LEVEL
CHECK BATTERY VOLTAGE
CHECK CHARGER CONDITION
CHECK MACHINE PERFORMANCE
SWEEPING POWER
VACUUM POWER
CONTROLS
GAUGES AND CONTROLS
CHECK WHEEL TRACKTION
GREASE FRONT WHEEL
SWEEPS AROUND TURNS

OTHER: _____

OTHER: _____

PAST HOUR METER READING:

CURRENT HOUR METER READING:

AVERAGE WEEKLY USAGE:

TECHNICIAN PRINT: _____

TECHNICIAN SIGNATURE: _____

DATE: _____

MANAGER SIGNATURE: _____

DATE: _____

TROUBLE SHOOTING

<u>PROBLEM</u>	<u>CAUSE</u>	<u>SOLUTION</u>
NO POWER, NOTHING OPERATES	FAULTY KEY SWITCH BATTERIES NEED CHARGING FAULTY BATTERY LOOSE BATTERY CABLE MAIN CIRCUIT BREAKER TRIPPED	CONTACT LOCAL SERVICING DEALER SEE CHARGING BATTERIES REPLACE BATTERY TIGHTEN LOOSE CABLE WAIT 5 MINUTES FOR AUTO RESET DETERMINE CAUSE AND CORRECT
MAIN BROOM DOES NOT OPERATE	MAIN BROOM IS NOT DOWN FOOT PEDAL IS NOT DEPRESSED MAIN BROOM CIRCUIT BREAKER TRIPPED CARBON BRUSHES WORN FAULTY MOTOR OR WIRES	PUT BRUSH DECK DOWN ENGAGE FOOT PEDAL WAIT 5 MINUTS FOR AUTO RESET DETERMINE CAUSE AND CORRECT CONTACT LOCAL SERVICING DEALER CONTACT LOCAL SERVICING DEALER
DRIVE MOTOR DOES NOT OPERATE	RECHARGE SWITCH MISADJUSTED FAULTY SPEED CONTROLLER OR WIRES FAULTY DRIVE MOTOR FAULTY WIRING CARBON BRUSHES WORN	CONTACT LOCAL SERVICING DEALER CONTACT LOCAL SERVICING DEALER CONTACT LOCAL SERVICING DEALER CONTACT LOCAL SERVICING DEALER CONTACT LOCAL SERVICING DEALER
DUST CONTROL FAN DOES NOT OPERATE	FAULTY VACUUM SWITCH VACUUM CIRCUIT BREAKER TRIPPED FAULTY VACUUM MOTOR CARBON BRUSHES WORN	TRY OPERATING "WHITE " TOGGLE WAIT 5 MINUTES FOR AUTO RESET DETERMINE CAUSE AND CORRECT CONTACT LOCAL SERVICING DEALER CONTACT LOCAL SERVICING DEALER
DRIVE MOTOR RUNS INCORRECTLY	FAULTY SPEED CONTROLLER OR WIRES FAULTY POTENTIOMETER LOOSE WIRES	CONTACT LOCAL SERVICING DEALER CONTACT LOCAL SERVICING DEALER CONTACT LOCAL SERVICING DEALER

TROUBLE SHOOTING

<u>PROBLEM</u>	<u>CAUSE</u>	<u>SOLUTION</u>
POOR DUST CONTROL	FILTER CLOGGED HOPPER NOT CLOSED TIGHTLY HOPPER GASKET FAULTY HOPPER FULL FAULTY VACCUM FAN BATTERY CHARGE IS LOW WET SEEP BY-PASS DOOR IS OPEN	TURN ON FILTER BEATER ADJUST SCREW ON HOPPER CLAMP TO TIGHTEN SEAL CONTACT LOCAL SERVICING DEALER REMOVE DEBRIS CONTACT LOCAL SERVICING DEALER CHARGE BATTERIES OVER NIGHT CLOSE BY-PASS DOOR.
POOR SWEEPING QUALITY	MAIN BROOM WORN OUT DEBRIS STUCK TO MAIN BROOM BROKEN MAIN BROOM BELT BROKEN MOTOR TO JACKSHAFT BELT MAIN BROOM BELT FELL OFF MOTOR TO JACK SHAFT BELT FELL OFF BATTERY CHARGE IS LOW BROOM HAS FLAT SPOT AND HAS "BROOM BOUNCE"	REPLACE MAIN BROOM REMOVE DEBRIS REPLACE BELT REPLACE BELT PUT BELT BACK ON PUT BELT BACK ON CHARGE BATTERIES OVER NIGHT REPLACE BROOM.
MAIN BROOM NOISY	DEBRIS STUCK IN MAIN BROOM MAIN BROOM OUT OF ROUND DEBRI STUCK IN MAIN BROOM BELT	REMOVE DEBRIS REPLACE MAIN BROOM REMOVE DEBRIS
REAR TIRES NOISY	BEARINGS DRY FAULTY HUBS	GREASE BEARINGS CONTACT LOCAL SERVICING DEALER
POOR TRACTION	EXCESSIVE MAIN BROOM PRESSURE WORN DRIVE TIRES	REDUCE PRESSURE WITH SWITCH CONTACT LOCAL SERVICING DEALER
SHORT RUN TIME	BATTERIES RUN DOWN BATTERIES STILL DOWN BATTERIES LOW ON WATER BATTERIES OVER CYCLED	CHARGE BATTERIES TWICE CONTACT LOCAL SERVICING DEALER FILL WITH DISTILLED WATER TO 3/4" ABOVE THE LEAD PLATES CONTACT LOCAL SERVICING DEALER

MODEL 48

PARTS BREAKDOWN

BLANK
THIS PAGE INTENTIONALLY LEFT BLANK

FRAME TOP

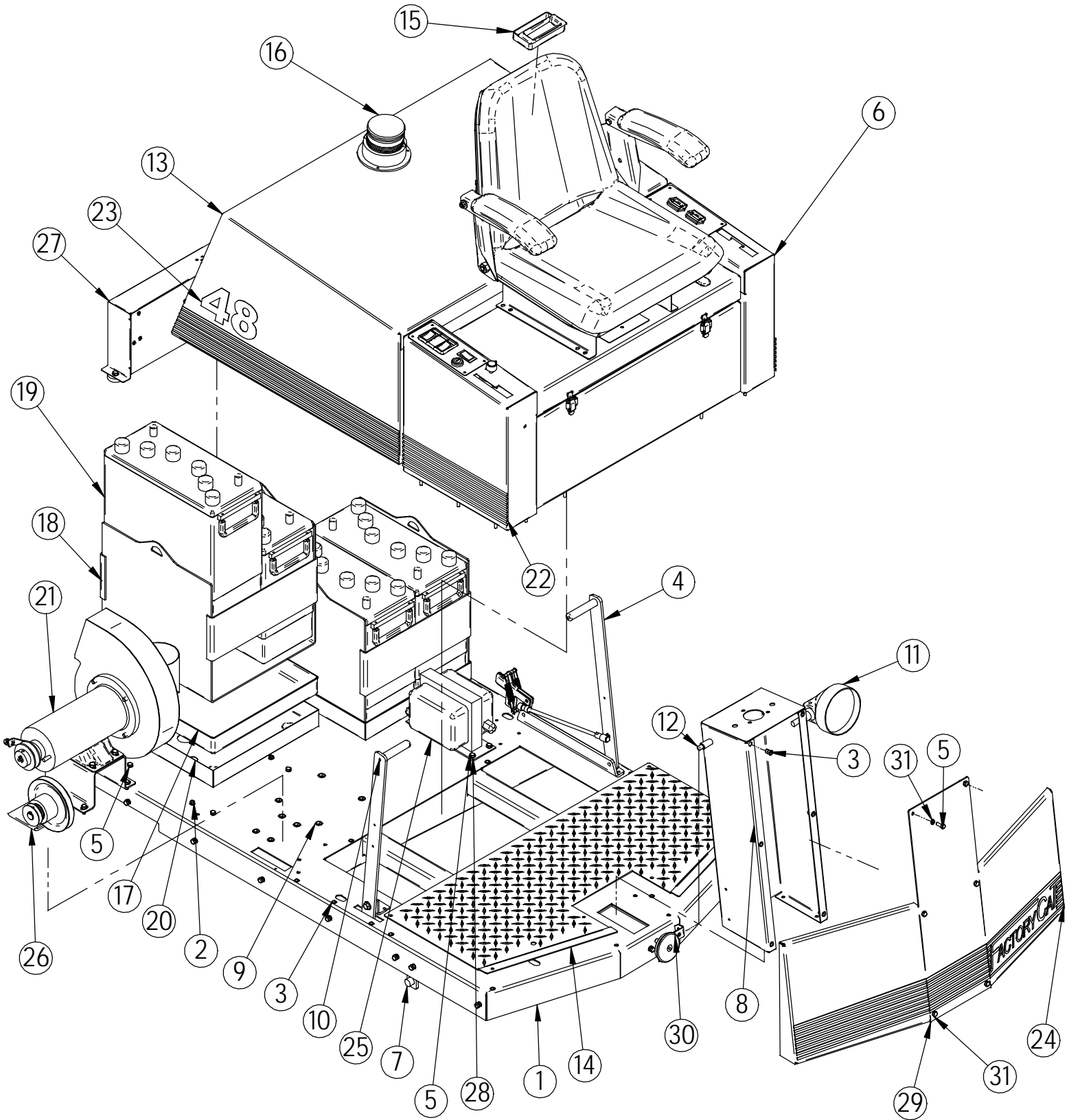

Item	48 Part No.	Part Description	Qty.
1	8-110	MAIN FRAME	1
2	H-19901	FB CASHD 1/4"-20 X 1/2"	2
3	H-250HCN	HCN 1/4"-20	27
4	SEE PG. 29 AND 30	MAIN BROOM LIFT ASM.	1
5	H-70003	HCS 1/4"- 20 X 3/4" SS	19
6	SEE PG. 33 AND 34	FILTER AND SEAT ASM	1
7	8-462	SIDE BROOM SUSPENSION AXLE	1
8	8-117	STEERING PEDESTAL	1
9	H-312HCN	HCN 5/16"-18	8
10	SEE PG. 31 AND 32	SIDE BROOM LIFT ARM ASM.	1
11	8-291	HEADLIGHT	1
12	8-294B	PUSH BUTTON SWITCH, SILVER	1
13	8-112	HOOD	1
14	8-161	NON-SKID FLOOR	1
15	8-144	HOOD HANDLE	1
16	8-293	STROBE LIGHT	1
17	8-148	BATTERY TRAY	2
18	8-159	REMOVABLE BATTERY BOX	2
19	4-270	BATTERY, 12 VOLT-135 AH	4
20	8-129	BATTERY BOX	2
21	SEE PG. 33 AND 34	MOTOR AND FAN ASM.	1
22	8-1501	PIN STRIPES	2
23	8-1500	48 STICKER	1
24	8-152	FRONT STICKER	1
25	8-244	BATTERY CHARGER	1
26	SEE PG. 33 AND 34	JACK SHAFT	1
27	SEE PG. 25 AND 26	CENTRAL COMMAND	1
28	H-71013	FW 1/4" X 5/8" SS	2
29	8-118	FRONT APRON	1
30	8-294	HORN	1
31	H-71063	LW 1/4" SS	14

FRAME BOTTOM

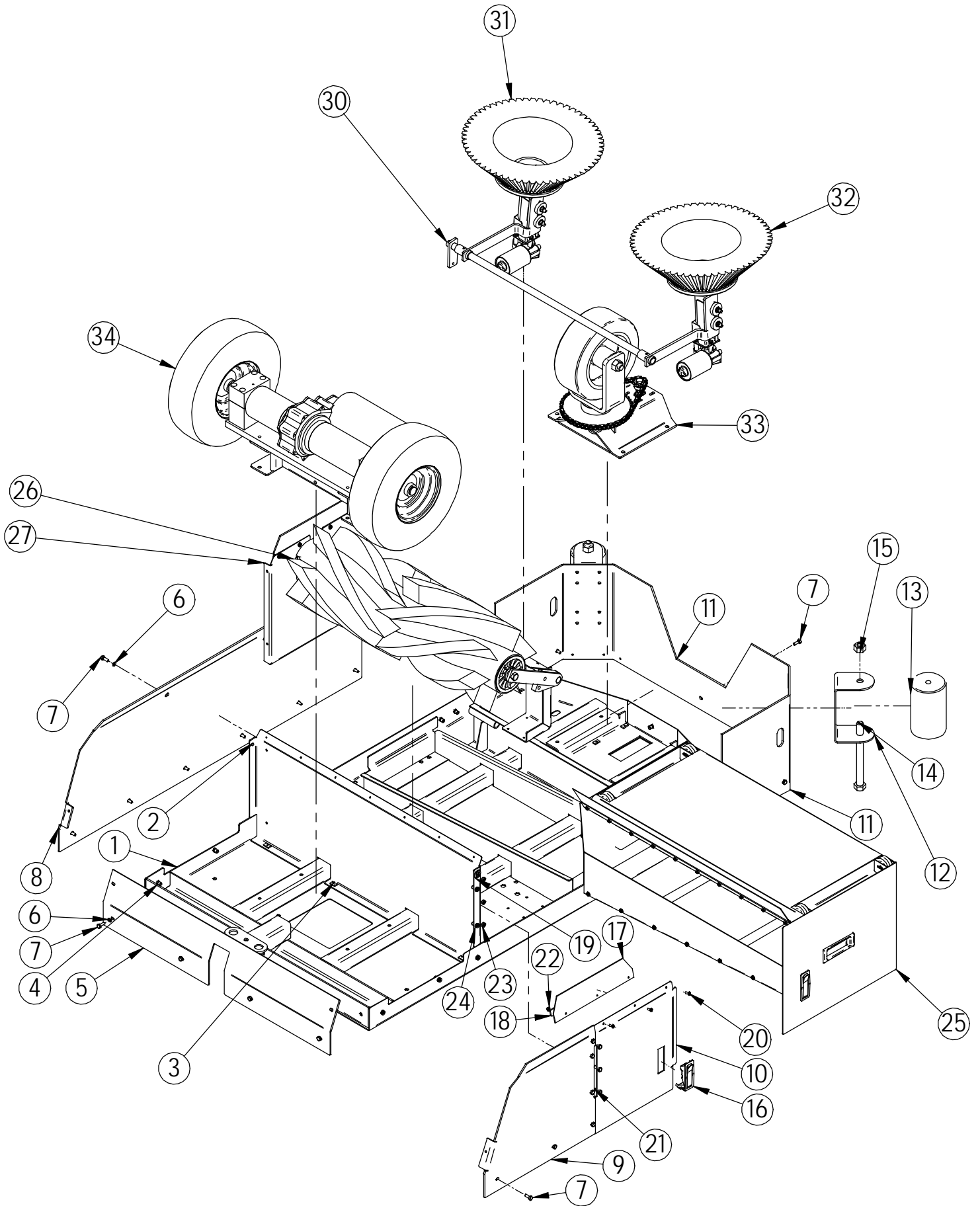

Item	Part No.	Part Description	Qty.
1	8-110	MAIN FRAME	1
2	8-125	BROOM COMPT. REAR PANEL	1
3	H-19901	FB CASHD 1/4"-20 X 1/2"	4
4	H-250HCN	HCN 1/4"-20	18
5	8-119H	REAR SKIRT	1
6	H-71063	LW 1/4" SS	22
7	H-70003	HCS 1/4"- 20 X 3/4" SS	22
8	8-120H	RIGHT HAND SKIRT	1
9	8-182H	LEFT REAR SKIRT	1
10	8-181	BROOM COMPARTMENT DOOR	1
11	8-135	FRONT BUMPER	1
12	7-126	HD ROLLER BRACKET	2
13	7-125A	ROLLER	2
14	H-11380	HCS 3/4"-10 X 8-1/2	2
15*	H-37039	NYLOK 3/4"- 10	2
16	5-130	SIDE DOOR LATCH	1
17	8-572	FLOOR SEAL, L.	1
18	8-577	LEFTHAND FLOOR SEAL CLAMP	1
19	H-	FNW 1/4" X 1" SS	1
20	H-29049	PPH #10-32 X 1/2"	3
21	H-13003	HCS 1/4"-20 X 3/4"	3
22	H-37408	KN #10-32	1
23	H-37018	NYLOK 1/4"-20	3
24	H-250RCN	RCN 1/4"- 20	2
25	SEE PG. 35 AND 36	HOPPER	1
26	SEE PG. 29 AND 30	MAIN BROOM ASM.	1
27	SEE PG 29 AND 30	INNER WALL	1
30	8-462	SIDE BROOM SUSPENSION AXLE	1
31	SEE PG. 31 AND 32	RIGHT SIDE BROOM ASM.	1
32	SEE PG. 31 AND 32	LEFT SIDE BROOM ASM.	1
33	SEE PG. 27 AND 28	FRONT WHEEL AND STEERING SYSTEM	1
34	SEE PG. 27 AND 28	REAR WHEEL DRIVE SYSTEM	1

CENTRAL COMMAND

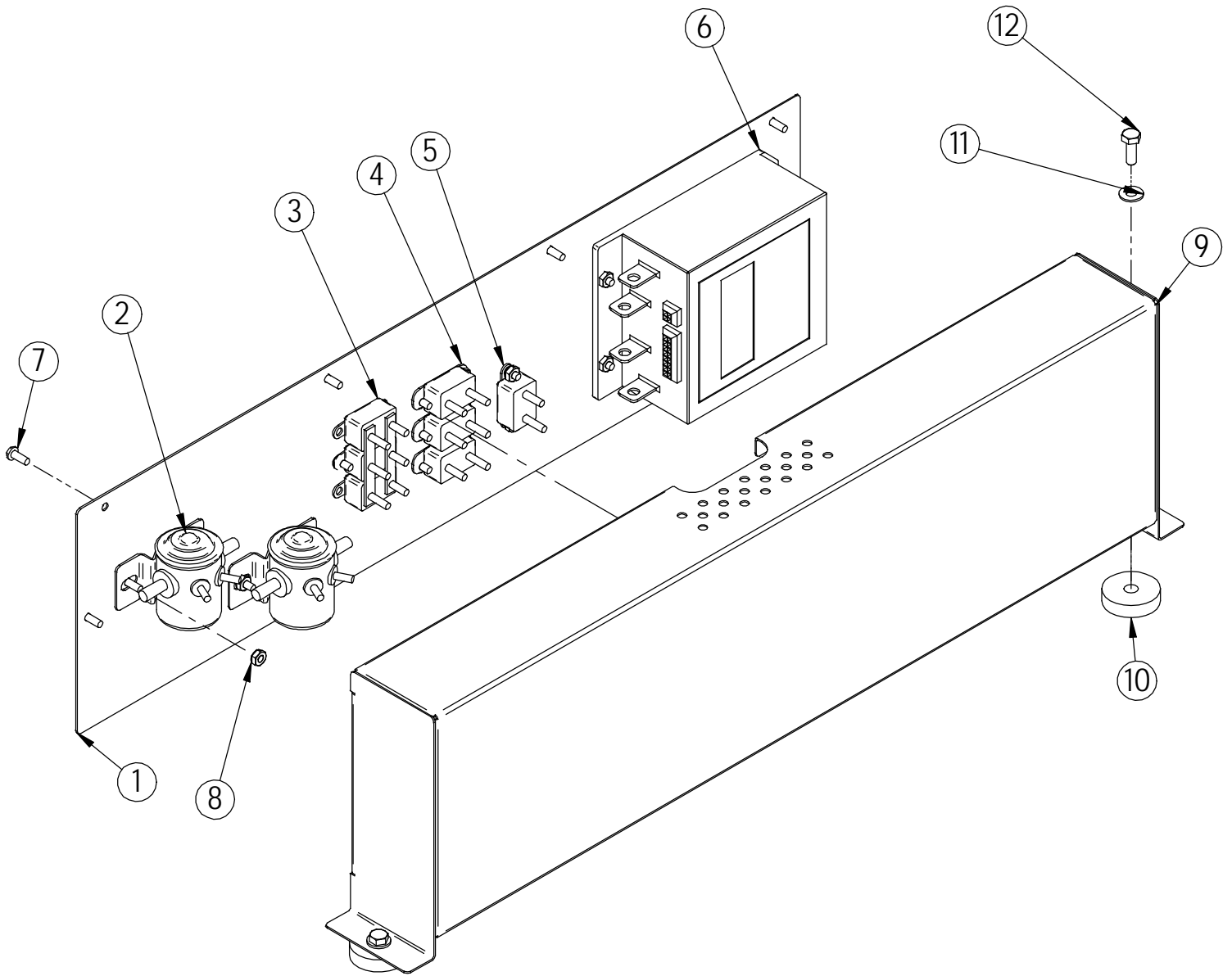

CENTRAL COMMAND

Item	Part No.	Part Description.	Qty.
1	8-288	CENTRAL COMAND BOX COVER	1
2	8-283	RELAY, 80 AMP	2
3	8-285	CIR. BREAKER - 120A	1
4	8-285A	CIR. BREAKER - 40A	3
5	8-285A	CIR BREAKER 24V 40A	1
6	8-289	COMPUTER CONTROL	1
7	H-29049	PPH #10-32 X 1/2"	23
8	H-37408	KN #10-32	17
9	8-287-00	C.C. BOX	1
10	4-446	GROMMET-3/8 ID X 1-1/2 OD X .375	2
11	H-71013	FW 1/4" X 5/8" SS	2
12	H-70003	HCS 1/4"- 20 X 3/4" SS	2

STEERING AND DRIVE SYSTEM

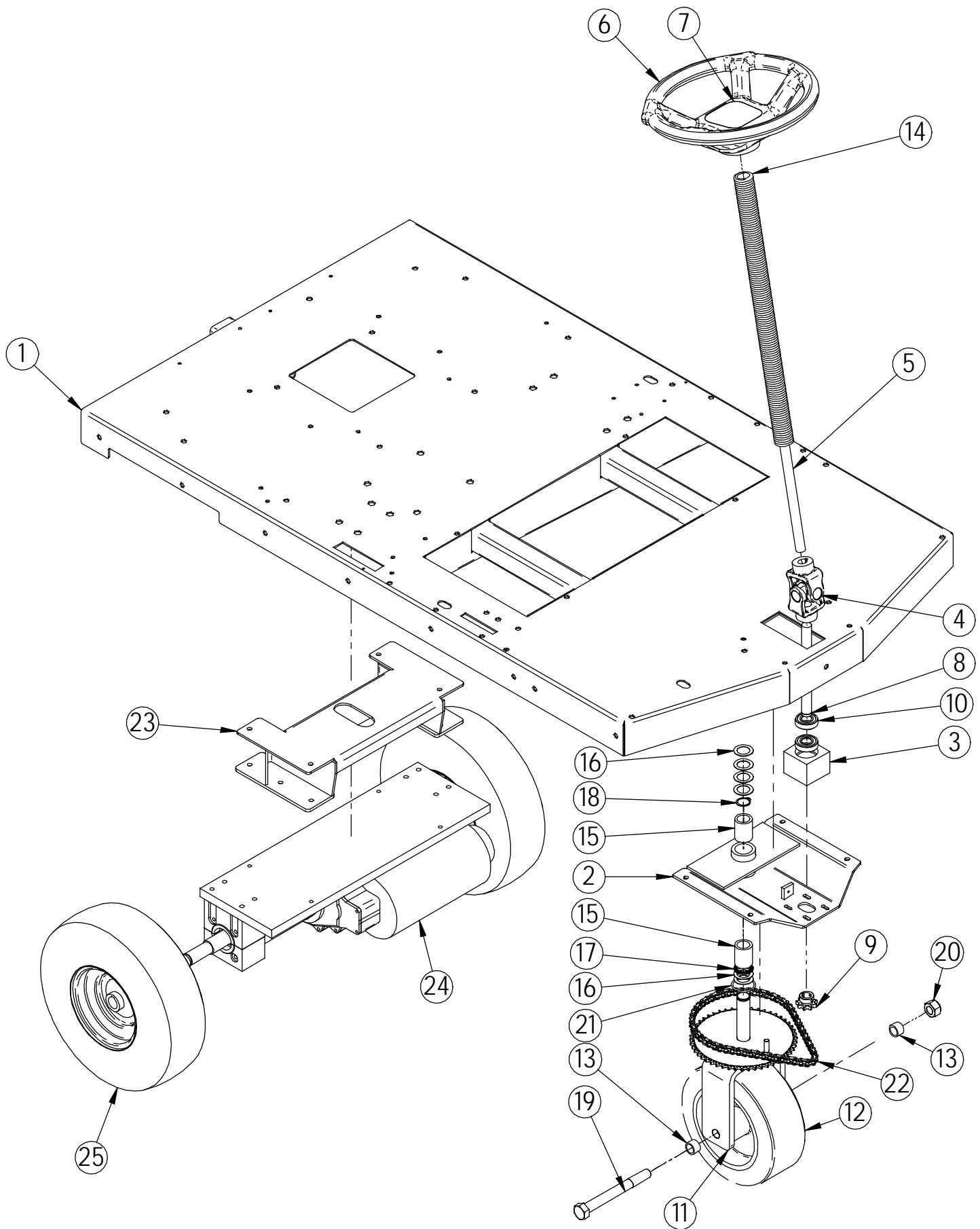

Item	Part No.	Part Description	Qty.
1	8-110	MAIN FRAME	1
2	8-720A	DROP PLATE	1
3	8-723	BEARING BLOCK	1
4	8-711-00	U-JOINT, STEERING	1
5	8-710	STEERING SHAFT, UPPER	1
6	8-701	STEERING WHEEL	1
7	8-701A	STEERING COVER	1
8	8-712	LOWER STEERING SHAFT	1
9	8-722	9 TOOTH SPROCKET	1
10	8-723B	BEARING	2
11	8-730	STEERING YOKE & SPROCKET	1
12	8-731	FRONT WHEEL	1
13	8-731	SPACER	2
14	8-710A	STEERING SHAFT COVER	1
15	8-725	YOKE PLATE BEARING	2
16	8-713	1 1/2" THRUST WASHER	6
17	8-714	THRUST BEARING	1
18	H-68019	SNAP RING 1"	1
19	H-13377	HB 3/4"- 10 X 7" SS	1
20	H-37039	NYLOK 3/4"- 10	1
21	8-715	O-RING	1
22	8-721	STEERING CHAIN	1
23	5-3100	AMER TRACTION MOUNT	1
24	5-604	TRANSAXLE	1
25	5-609	REAR WHEEL	2

MAIN BROOM AND LINKAGE

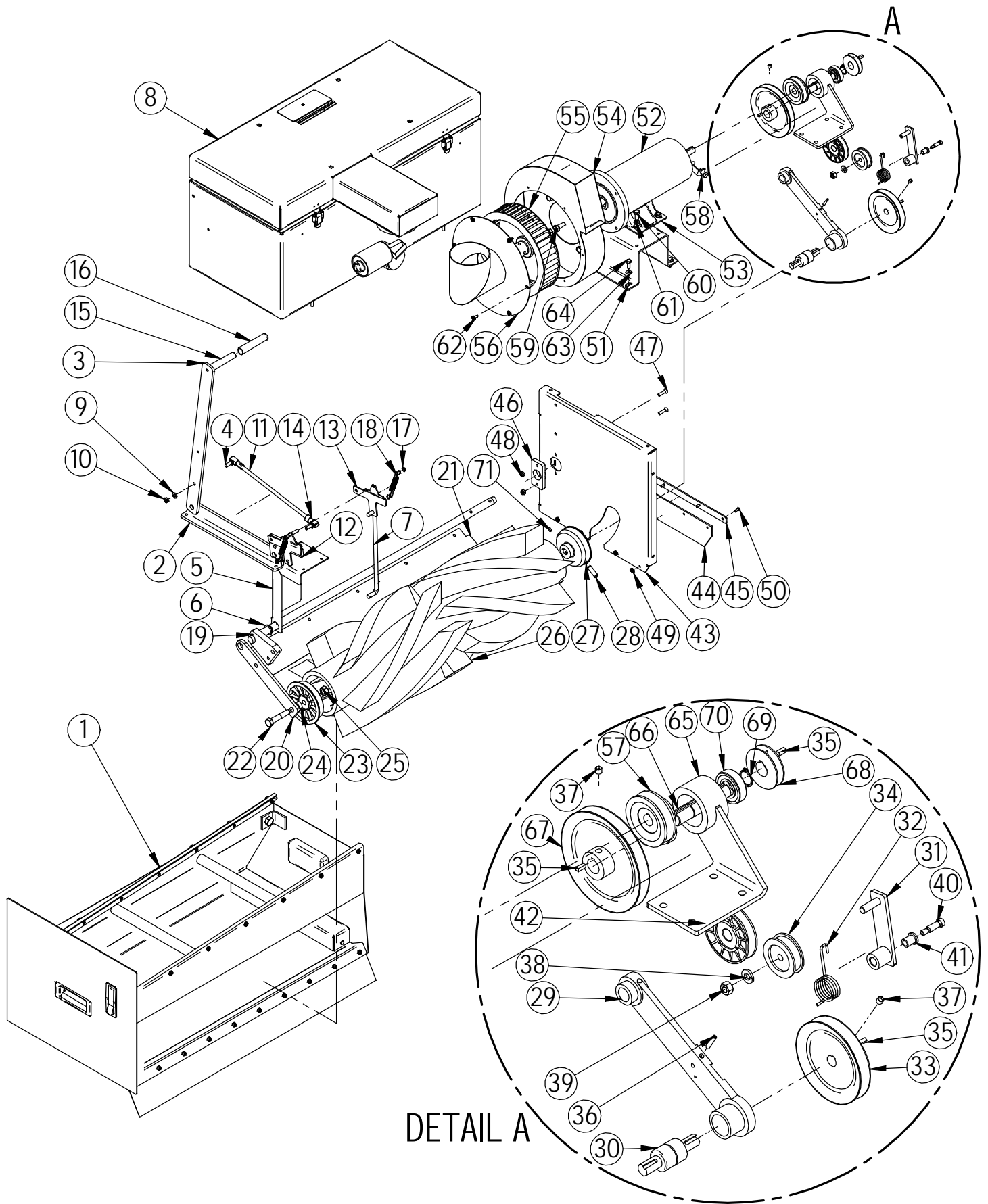

DETAIL A

Item	Part No.	Part Description	Qty
1	SEE PG. 35 AND 36	HOPPER	1
2	8-454	MAIN BROOM LINKAGE CHASSIS	1
3	8-451	MAIN BROOM LIFT LEVER	1
4	8-455A	FIXED BALL JOINT END FITTING 5/16"-24	1
5	8-423	LEFT SUPPORT BEARING	1
6	8-423A	MAIN BROOM BEARING SHELL	1
7	8-440	MAIN BROOM VERT LINK	1
8	SEE PG. 33 AND 34	FILTER AND SEAT ASM	1
9	H-71065	LW 5/16" SS	1
10	H-36102	HN 1/4"-20	1
11	8-455C	THRD ROD 5/16"-24	1
12	8-434-00	BELLCRANK PLATE	1
13	8-433	BELL CRANK COVER	1
14	8-455B	REMOV. BALL JOINT END FITTING 5/16"-24	1
15	8-452	LIFT HANDLE	1
16	4-448	HANDLE GRIP	1
17	8-437	3/8" WASHER CAP NUT	4
18	8-436	DOWN PRESSURE CONTROL SPRING	4
19	8-410	MAIN BROOM SUSPENSION ARM	1
20	4-430	IDLER ARM	1
21	8-414	ATTENUATOR	1
22	H-13213	HB 1/2" X 2 1/2"	1
23	4-432	IDLER DRUM	1
24	4-432A	IDLER DRUM SPACER	1
25	H-37030	NYLOK 1/2"-13	1
26	8-401US	MAIN BROOM, UNION STEEL	1
27	4-420	BROOM DRIVER	1
28	H-10436-0 105	3/8" X 1 1/4" SPRING PIN	2
29	4-416	BROOM LATERAL ARM	1
30	4-412	BROOM DRIVE BEARING	1
31	4-360	REVERSE IDLER ARM	1
32	4-319	TENSION SPRING	1
33	4-316	BROOM DRIVE PULLEY	1
34	4-317	IDLER PULLEY	1

Item	Part No.	Part Description	Qty
35	H-K1432	3/16" X 1/2" KEY	3
36	H-25283	SSS CP #10-32 X 1"	1
37	H-25435	SSS CP 5/16" X 1/4"	2
38	H-33622	LW 3/8"	1
39	H-36106	HN 3/8"-16	1
40	H-26316	SB 5/16" X 3/4" SS	1
41	4-366	BUSHING, IDLER ARM	1
42	4-318	IDLER PULLEY	1
43	8-127	BROOM COMPARTMENT INNER PANEL	1
44	8-574	FLOOR SEAL, R.	1
45	8-576	RIGHTHAND FLOOR SEAL CLAMP	1
46	4-421	SUPPORT BLOCK	1
47	H-29570	FHP 1/4"-20 X 1"	2
48	H-37018	NYLOK 1/4"-20	2
49	H-37408	KN #10-32	4
50	H-29048	RPH #10-32 X 1/2"	4
51	8-165	MOTOR SUPPORT BRACKET	1
52	8-201	24V,TWIN SHAFT MOTOR	1
53	4-201B	MOTOR CRADLE	1
54	4-511	BLOWER HOUSING	1
55	4-512	BLOWER WHEEL	1
56	4-513	BLOWER DOOR	1
57	4-301	MAIN DRIVE PULLEY	1
58	4-210	TERMINAL CLIP	1
59	H-13105	HCS 3/8" - 16 X 1"	4
60	H-13053	HCS 5/16"-18 X 3/4"	5
61	H-33620	LW 5/16"	4
62	H-31810	HW #10 X 1/2	5
63	H-71013	FW 1/4" X 5/8" SS	3
64	H-70003	HCS 1/4" - 20 X 3/4" SS	3
65	8-628	MAIN BROOM JACKSHEFT BRACKET	1
66	8-641	JACKSHAFT SHAFT	1
67	4-312	TRANS INPUT PULLEY	1
68	4-320	BROOM DRIVE PULLEY	1
69	H-68015	SNAPRING 3/4"	2
70	8-723B	BEARING	2
71	H-25328	SSS CP 1/4"-20 X 3/8"	2

SIDE BROOMS AND LINKAGE

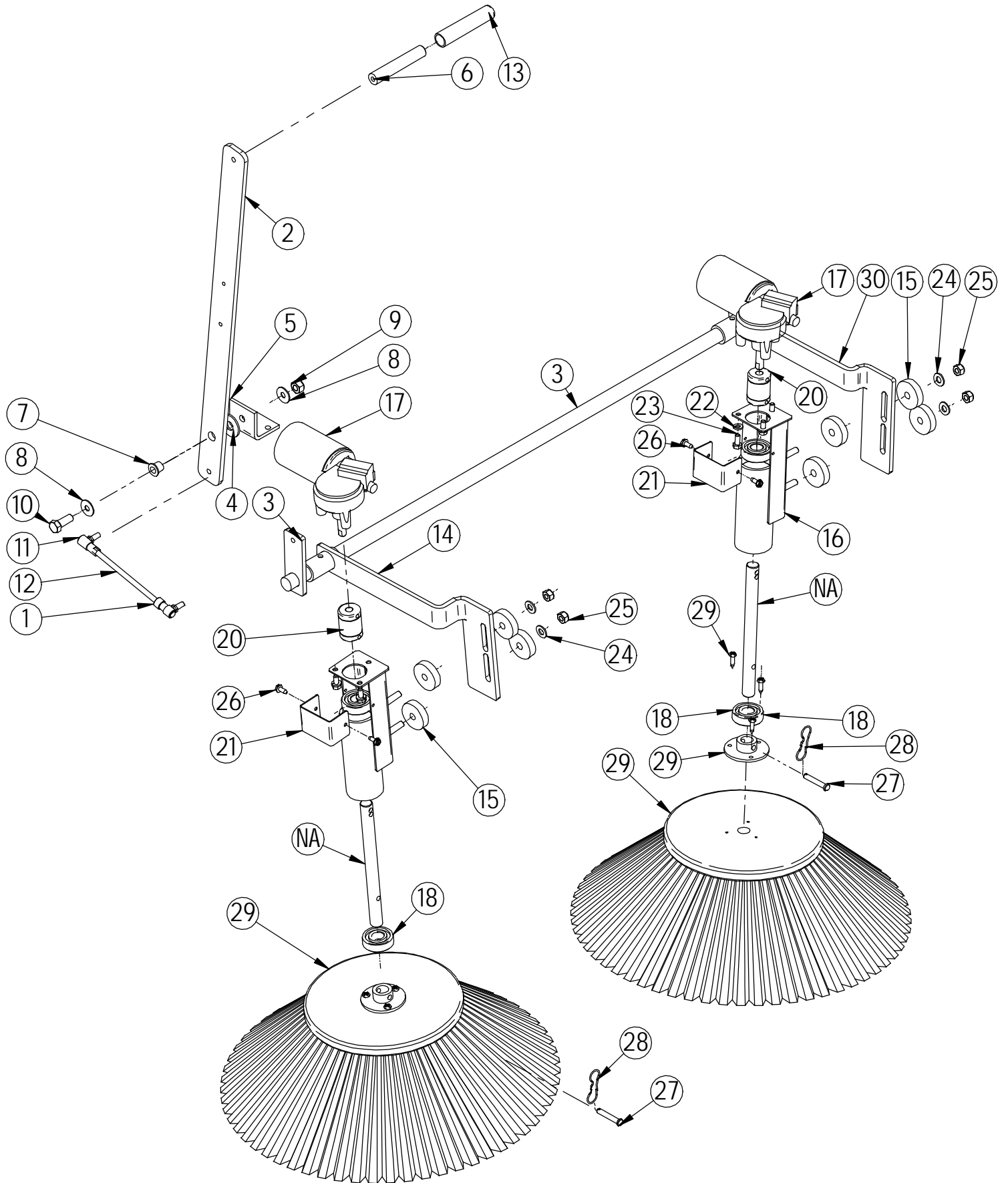

Item	Part No.	Part Description	Qty
1	8-553B	REMOV. BALL JOINT END FITTING 1/4"-28	1
2	8-461	LEVER, SIDE BROOM	1
3	8-462	SIDE BROOM SUSPENSION AXLE	1
4	H-33012	FW 1/2" SS	1
5	8-467	LIFT LEVER ANGLE	1
6	8-452	LIFT HANDLE	1
7	H 00702	FLANGE BUSHING	1
8	H-71016	FW 5/16" X 7/8" USS	2
9	H-77862	NYLOK 3/8"- 16 SS	1
10	H-70105	HCS 3/8"- 16 X 1" SS	1
11	8-453A	FIXED BALL JOINT END FITTING 1/4"-28	1
12	8-463C	THRD ROD 1/4"-20	1
13	4-448	HANDLE GRIP	1
14	8-442	RIGHT SIDE BROOM ANGLE	1
15	4-446	GROMMET-3/8 ID X 1-1/2 OD X .375	8
16	4-445A	BROOM MOTOR MOUNT	2
17	8-220	SIDE BROOM MOTOR	2
18	4-445C	DRIVE TUBE BEARING	4
19	4-445B	SHAFT	2
20	4-444	BROOM SAFETY DRIVE CPLG	2
21	4-139	COUPLING COVER	2
22	H-33618	LW 1/4"	6
23*	H-38558	HCS M6-1.0 X 14	6
24	H-33080	FW 5/16" SAE	4
25	H-37021	NYLOK 5/16"-18	4
26	H-31810	HW #10 X 1/2	4
27	H-ZCP44	1/4" X 1 1/2" CLEVIS PIN	2
28	H-BOW72	1/4" LOCKING COTTER	2
29	4-402	SIDE BROOM POLYPROPYLENE	2
30	8-443	LEFT SIDE BROOM ANGLE	1

FILTERING SYSTEM AND SEAT

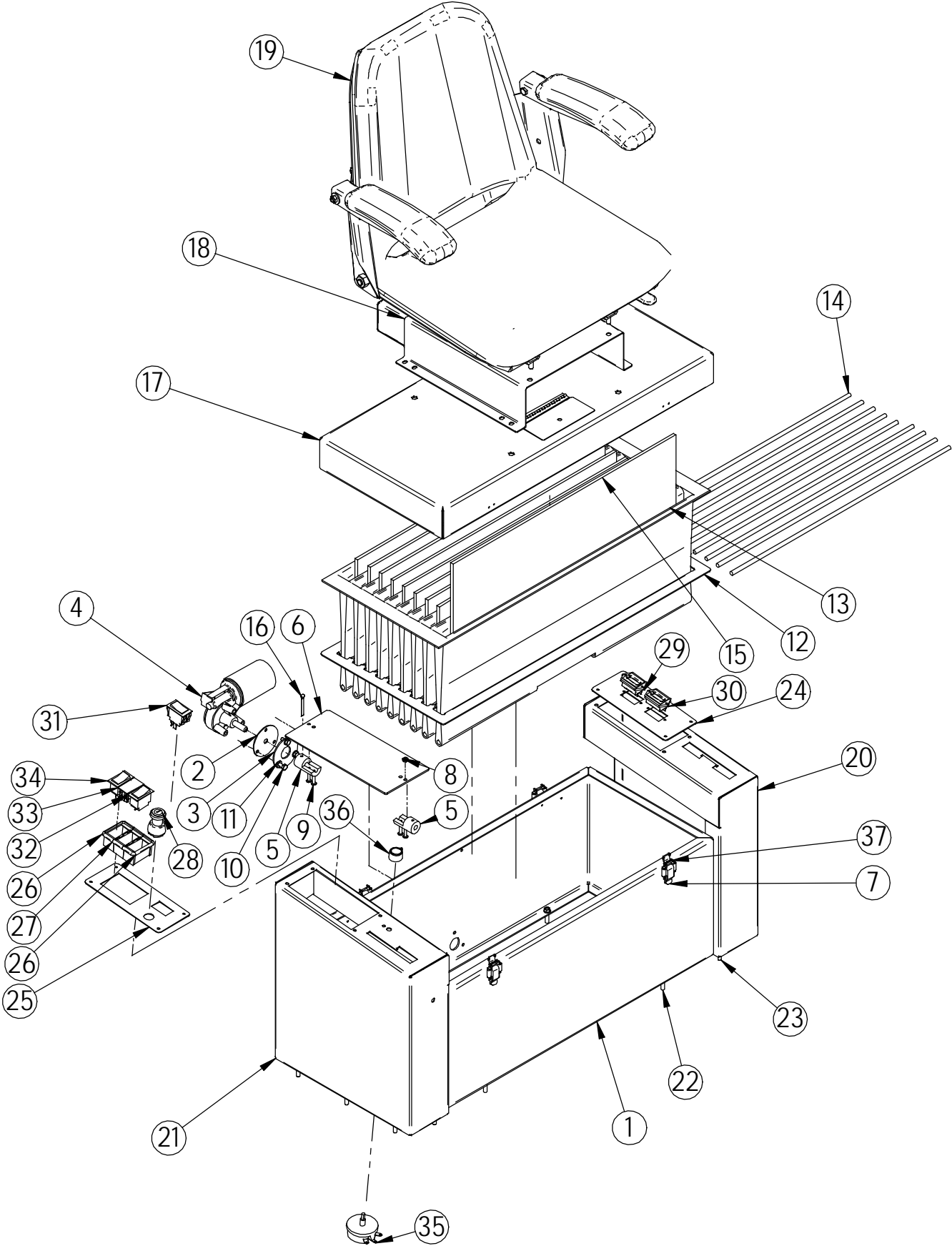

Item No.	Part Number	Part Description	Qty
1	8-140	FILTER CHAMBER	1
2	8-222	MOTOR GASKET	1
3	8-223	GASKET BACKING PLATE	1
4	8-221	FILTER CLEANER/SIDE BROOM MOTOR	1
5	8-561	FILTER CLEANER MOTOR COUPLER	2
6	8-506	FILTER BEATER BAR PLATE	1
7	8-138A	LATCH W/SPRING	4
8	H-37015	NYLOK #10-32	1
9	H-29073	PPH #10-32 X 1"	4
10	H-38558	HCS M6-1.0 X 14	3
11	H-33618	LW 1/4"	11
12			1
13	8-502	FILTER ELEMENT	1
14	4-503A	FILTER WEIGHT ROD	9
15	4-521A	FILTER SEPARATOR	9
16	H-65105	1/4" X 1 1/5" COTTER PIN	1
17	8-141	FILTER CHAMBER LID	1
18	8-160	SEAT STAND	1
19	8-143	SEAT WITH ARM RESTS	1
20	8-116	LEFT HAND CONTROL PANEL	1
21	8-115	RIGHT HAND CONTROL PANEL	1
22	H-19905	FB CASHD 1/4"-20 X 1.0"	4
23	H-13005	HCS 1/4"-20 X 1"	8
24	8-132	LEFT HAND INSTRUMENT PANEL	1
25	8-131	RIGHT HAND INSTRUMENT PANEL	1
26	8-234A	SWITCH BRKT, SIDE	2
27	8-236	SWITCH BRKT, CENTER	1
28	8-234	KEY SWITCH	1
29	8-261	BATTERY COND METER	1
30	8-262	HOUR METER (optional)	1
31	4-230	ROCKER SWITCH	1
32	8-231	SWITCH, ON-OFF ROCKER SPST	1
33	8-232	GREEN INDICATOR LIGHT	1
34	8-233	OFF-MOM SPST	1
35	4-451	RHEOSTAT	1
36	4-452	RED CONTROL KNOB	1
37	8-138b	LATCH	2

HOPPER

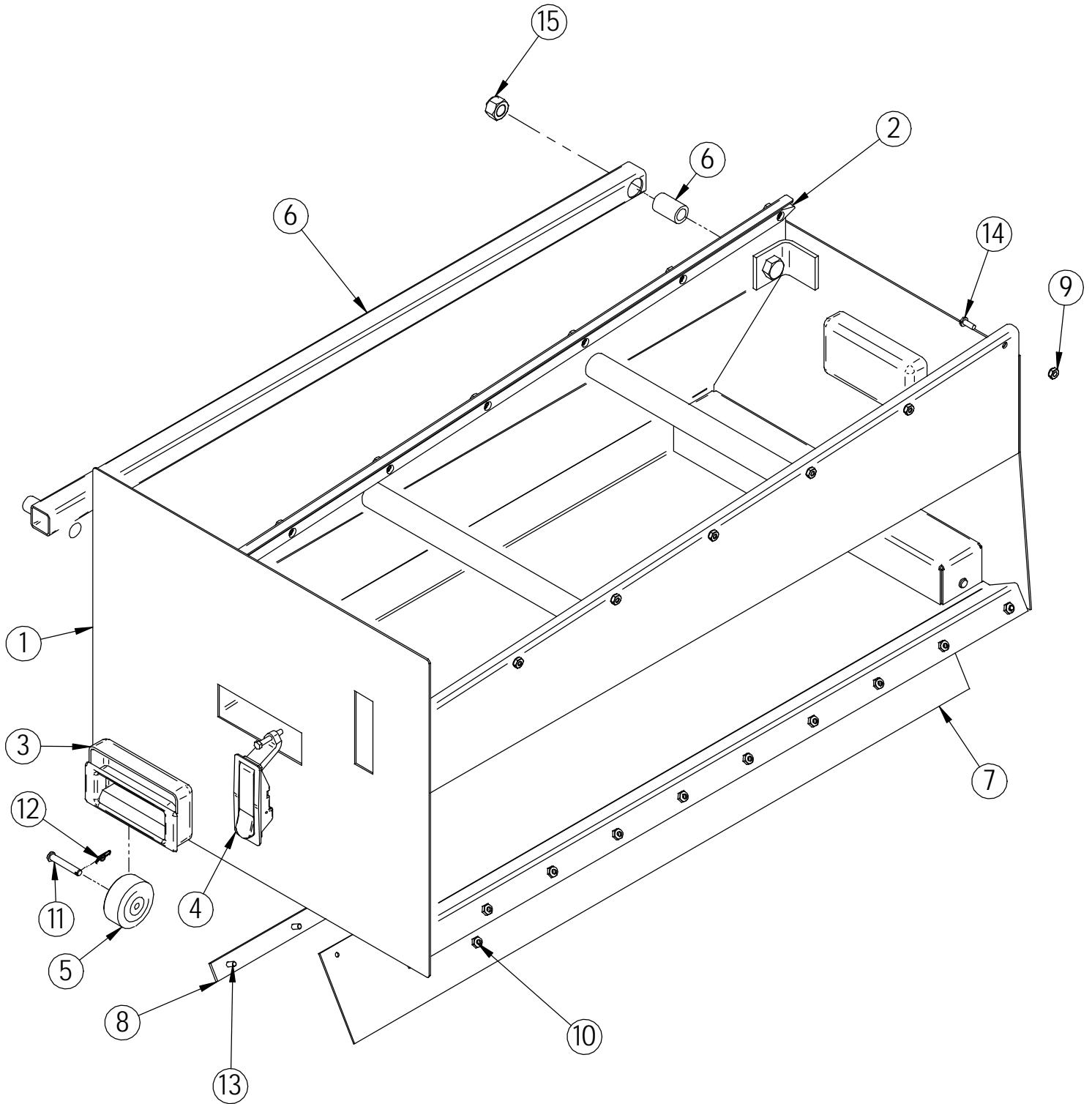

Item Number	Document Number	Title	Quantity
1	8-123	HOPPER BODY	1
2	8-163	HDPE SLIDE RAIL	2
3	4-127	HANDLE	2
4	5-130	SIDE DOOR LATCH	1
5	8-124A	HOPPER WHEEL	4
6	8-128	HOPPER HANDLE	1
7	8-573	REAR FLOOR SEAL	1
8	8-575	HOPPER FLOOR SEAL CLAMP	1
9	H-37408	KN #10-32	14
10	H-37015	NYLOK #10-32	10
11	H-ZCP44	1/4" X 1 1/2" CLEVIS PIN	4
12	H-RUE8	RUE RING COTTER	4
13	H-71671	HXMS #10-32 X 1/2" SS	10
14	H-29049	PPH #10-32 X 1/2"	14
15	H-37030	NYLOK 1/2"-13	1