

TOSHIBA

FILE NO. 060-200565GR
SUPPLEMENT

SERVICE MANUAL

Color Television

S5ES series

29CZ5DE
29CZ5T
29CZ6SI

The above models are classified as green products (*1), as indicated by the underlined serial numbers. This Service Manual describes replacement parts for the green products. When repairing these green product (s), use the part (s) described in this manual and lead-free solder (*2).

For (*1) and (*2), see the next page.

TABLE OF CONTENTS

CHAPTER 1 GENERAL ADJUSTMENTS

SAFETY INSTRUCTIONS	3
SET-UP ADJUSTMENT	4
SERVICE MODE	8
DESIGN MODE	11
ELECTRICAL ADJUSTMENTS	12
CIRCUIT CHECK	13

CHAPTER 2 SPECIFIC INFORMATIONS

SETTING & ADJUSTING DATA	14
NAMES AND FUNCTIONS OF CONTROLS	15
PROGRAMMING CHANNEL MEMORY	16
PROCEDURES TO SET HOTEL MODE	18
CHASSIS AND CABINET REPLACEMENT PARTS LIST	19
PC BOARDS BOTTOM VIEW	26
TERMINAL VIEW OF TRANSISTORS	30
CIRCUIT BLOCK DIAGRAM	32
SPECIFICATIONS	END

APPENDIX:

CIRCUIT DIAGRAM

(*1)

GREEN PRODUCT PROCUREMENT

The EC is actively promoting the WEEE & RoHS Directives that define standards for recycling and reuse of Waste Electrical and Electronic Equipment and for the Restriction of the use of certain Hazardous Substances. From July 1, 2006, the RoHS Directive will prohibit any marketing of new products containing the restricted substances.

Increasing attention is given to issues related to the global environmental. Toshiba Corporation recognizes environmental protection as a key management tasks, and is doing its utmost to enhance and improve the quality and scope of its environmental activities. In line with this, Toshiba proactively promotes Green Procurement, and seeks to purchase and use products, parts and materials that have low environmental impacts.

Green procurement of parts is not only confined to manufacture. The same green parts used in manufacture must also be used as replacement parts.

(*2)

LEAD-FREE SOLDER

This product is manufactured using lead-free solder as a part of a movement within the consumer products industry at large to be environmentally responsible. Lead-free solder must be used in the servicing and repair of this product.

WARNING

This product is manufactured using lead free solder.

DO NOT USE LEAD BASED SOLDER TO REPAIR THIS PRODUCT!

The melting temperature of lead-free solder is higher than that of leaded solder by 86°F to 104°F (30°C to 40°C). Use of a soldering iron designed for lead-based solders to repair product made with lead-free solder may result in damage to the component and or PCB being soldered. Great care should be made to ensure high-quality soldering when servicing this product -especially when soldering large components, through-hole pins, and on PCBs - as the level of heat required to melt lead-free solder is high.

SAFETY INSTRUCTIONS

WARNING: BEFORE SERVICING THIS CHASSIS, READ THE “X-RAY RADIATION PRECAUTION”, “SAFETY PRECAUTION” AND “PRODUCT SAFETY NOTICE” INSTRUCTIONS BELOW.

X-RAY RADIATION PRECAUTION

1. Excessive high voltage can produce potentially hazardous X-RAY RADIATION. To avoid such hazards, the high voltage must not be above the specified limit. The nominal value of the high voltage of this receiver is (A) kV at zero beam current (minimum brightness) under a (C) V AC power source. The high voltage must not, under any circumstances, exceed (B) kV.
2. The only source of X-RAY RADIATION in this TV receiver is the picture tube. For continued X-RAY RADIATION protection, the replacement tube must be exactly the same type tube as specified in the parts list.
3. Some part in this receiver have special safety-related characteristics for X-RAY RADIATION protection. For continued safety, parts replacement should be undertaken only after referring to the PRODUCT SAFETY NOTICE below.

Refer to table-1 for high voltage (A), (B) & AC voltage (C).
(See SETTING & ADJUSTING DATA on page 14)

Each time a receiver requires servicing, the high voltage should be checked following the HIGH VOLTAGE CHECK procedure in this manual. It is recommended that the reading of the high voltage be recorded as a part of the service record. It is important to use an accurate and reliable high voltage meter.

SAFETY PRECAUTION

WARNING : Service should not be attempted by anyone unfamiliar with the necessary precautions on this receiver. The following are the necessary precautions to be observed before servicing this chassis.

1. An isolation transformer should be connected in the power line between the receiver and the AC line before any service is performed on the receiver.
2. Always discharge the picture tube anode to the CRT conductive coating before handling the picture tube. The picture tube is highly evacuated and if broken, glass fragments will be violently expelled. Use shatter proof goggles and keep picture tube away from the unprotected body while handling.
3. When replacing a chassis in the cabinet, always be certain that all the protective devices are put back in place, such as; nonmetallic control knobs, insulating covers, shields, isolation resistor-capacitor network etc.

PRODUCT SAFETY NOTICE

Many electrical and mechanical parts in this chassis have special safety-related characteristics. These characteristics are often passed unnoticed by a visual inspection and the protection afforded by them cannot necessarily be obtained by using replacement components rated for higher voltage, wattage, etc. Replacement parts which have these special safety characteristics are identified in this manual and its supplements; electrical components having such features are identified by the international hazard symbols on the schematic diagram and the parts list.

Before replacing any of these components, read the parts list in this manual carefully. The use of substitute replacement parts which do not have the same safety characteristics as specified in the parts list may create shock, fire, X-ray radiation or other hazards.

WARNING: BEFORE SERVICING THIS CHASSIS, READ THE "X-RAY RADIATION PRECAUTION", "SAFETY PRECAUTION" AND "PRODUCT SAFETY NOTICE" ON PAGE 3 OF THIS MANUAL.

SET-UP ADJUSTMENT

■ The following adjustments should be made when a complete realignment is required or a new picture tube is installed. Perform the adjustments in order as follows :

1. Color Purity
2. Convergence
3. White Balance

Note: The PURITY/CONVERGENCE MAGNET assembly and rubber wedges need mechanical positioning. Refer to figure 1.

Mounting position of the purity magnet assembly should fit to same position as old one because slightly difference to the position depend on a kind of tube.

* There are no adjustment of purity and convergence in some picture tube (Unified with purity magnet)

COLOR PURITY ADJUSTMENT

NOTE : Before attempting any purity adjustments, the receiver should be operated for at least fifteen minutes.

1. Demagnetize the picture tube and cabinet using a degaussing coil.
2. Set the brightness and contrast to maximum.
3. Use a green raster from a signal generator.
4. Loosen the clamp screw holding the yoke and slide the yoke backward or forward to provide vertical green belt (zone) in the picture screen.

5. Remove the Rubber Wedges.
6. Rotate and spread the tabs of the purity magnet (See figure 2.) around the neck of the picture tube until the green belt is in the center of the screen. At the same time, enter the raster vertically.
7. Slowly move the yoke forward or backward until a uniform green screen is obtained. Tighten the clamp screw of the yoke temporarily.
8. Check the purity of the red and blue raster.

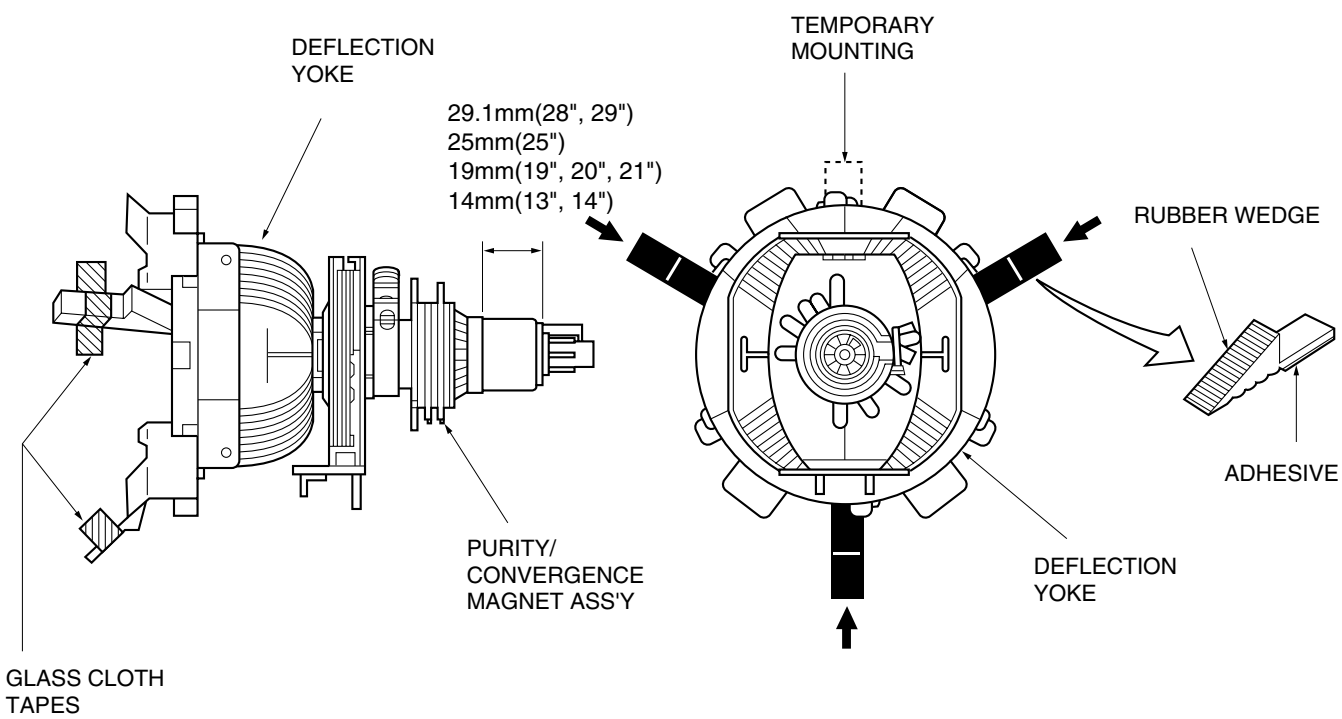

Figure 1.

CONVERGENCE ADJUSTMENTS

NOTE: Before attempting any convergence adjustments, the receiver should be operated for at least fifteen minutes.

■ CENTER CONVERGENCE ADJUSTMENT

1. Use the cross-dot pattern from a signal generator.
2. Set the brightness and contrast for well defined pattern.
3. Adjust two tabs of the 4-Pole Magnets to change the angle between them (See figure 2.) and superimpose red and blue vertical lines in the center area of the picture screen.
4. Turn the both tabs at the same time keeping the angle constant to superimpose red and blue horizontal lines at the center of the screen.
5. Adjust two tabs of 6-Pole Magnets to superimpose red/blue line and green one. Adjusting the angle affects the vertical lines and rotating both magnets affects the horizontal lines.
6. Repeat adjustments 3, 4, 5 keeping in mind red, green and blue movement, because 4-Pole Magnets and 6-Pole Magnets have mutual interaction and make dot movement complex.

■ CIRCUMFERENCE CONVERGENCE ADJUSTMENT

1. Loosen the clamping screw of deflection yoke slightly to allow the yoke to tilt.
2. Temporarily put a wedge as shown in figure 1. (Do not remove cover paper on adhesive part of the wedge.)
3. Tilt front of the deflection yoke up or down to obtain better convergence in circumference. (See figure 3.) Push the mounted wedge into the space between picture tube and the yoke to fix the yoke temporarily.
4. Put other wedge into bottom space and remove the cover paper to stick.
5. Tilt front of the yoke right or left to obtain better convergence in circumference. (See figure 3.)
6. Keep the yoke position and put another wedge in either upper space. Remove cover paper and stick the wedge on picture tube to fix the yoke.
7. Detach the temporarily mounted wedge and put it in another upper space. Stick it on picture tube to fix the yoke.
8. After fixing three wedges, recheck overall convergence. Tighten the screw firmly to fix the yoke and check the yoke is firm.
9. Stick three adhesive tapes on wedges as shown in figure 1.

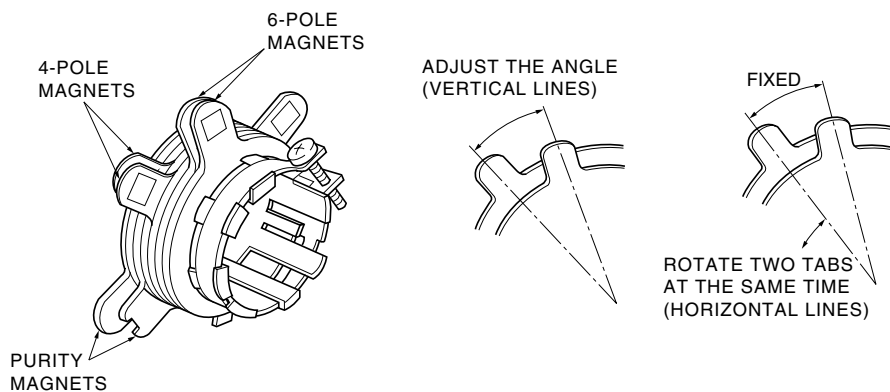

CONVERGENCE MAGNET ASSEMBLY

ADJUSTMENT OF MAGNETS

Figure 2.

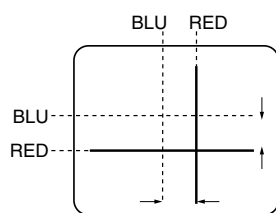

4-POLE MAGNETS MOVEMENT

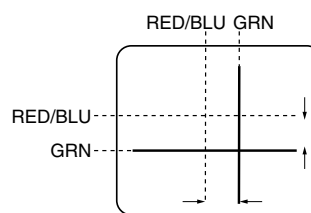

6-POLE MAGNETS MOVEMENT

Center Convergence by Convergence Magnets

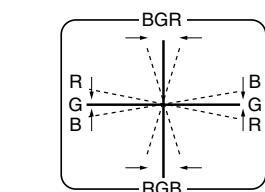

INCLINE THE YOKE UP (OR DOWN)

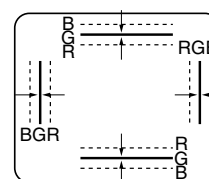

INCLINE THE YOKE RIGHT (OR LEFT)

Circumference Convergence by DEF Yoke

Figure 3. Dot Movement Pattern

WARNING: BEFORE SERVICING THIS CHASSIS, READ THE "X-RAY RADIATION PRECAUTION", "SAFETY PRECAUTION" AND "PRODUCT SAFETY NOTICE" ON PAGE 3 OF SERVICE MANUAL.

SET-UP ADJUSTMENT (FOR FLAT TUBE)

■ The following adjustments should be made when a complete realignment is required or a new picture tube is installed. Perform the adjustments in order as follows :

1. Color Purity
2. Convergence
3. White Balance

Note: The PURITY/CONVERGENCE MAGNET assembly and rubber wedges need mechanical positioning. Refer to figure 1.

COLOR PURITY ADJUSTMENT

- (1) Let the screen face in the installing direction or toward the east (when it is to be moved), bring up the service mode screen after demagnetizing (front, left, right, and top) with the degaussing coil, receive white signals by pressing the [TV/VIDEO] button, and then the receiver should be operated for more than 40 minutes.
- (2) Perform rough adjustment of the central convergence with the P/C magnet according to the adjustment item.
- (3) Receive built-in green signals, loosen set screws on the deflection yoke, remove rubber wedges, and shift the deflection yoke toward front.
- (4) Move alternately the two 2-pole magnets of the P/C magnets so that the green raster can come to the center of the screen.

Figure 1.

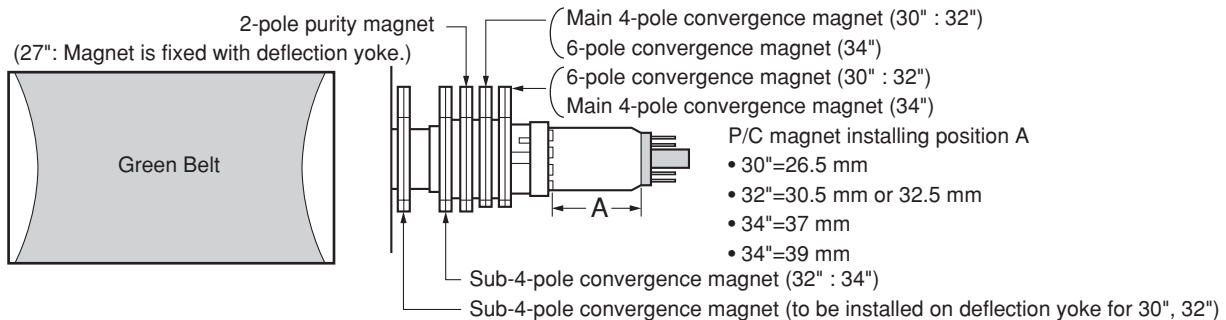

- (5) Receive built-in red and blue signals, check that there is no inclination of the single color raster toward one side, and if each color tilts to a great extent, make adjustment with the 2-pole magnet so that the 3 colors will come to the center evenly.
- (6) Receive the green raster, shift the deflection yoke from a foremost position (hitting against the picture tube) to a backward position horizontally, stop the deflection yoke at a position where it begins to become a green raster, and perform accurate marking on the picture tube.
- (7) Shift the deflection yoke further backward, and perform accurate marking at a position where the green raster begins to be off.
- (8) Fix the deflection yoke at a position 60% forward within the range marked in items (6) and (7) above.

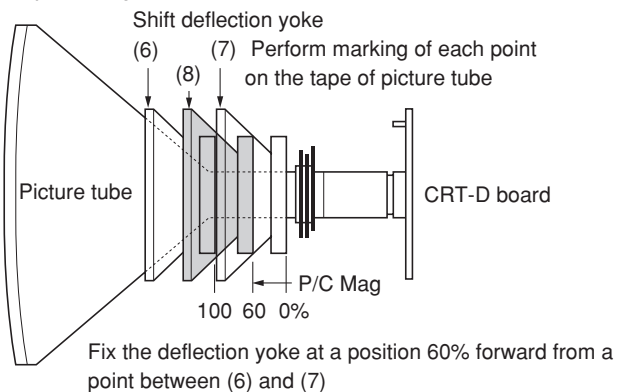

CONVERGENCE ADJUSTMENTS

* Adjust the convergence magnet to get vest convergence in the the order to (1) ~ (5).

■ CENTER CONVERGENCE:

- (1) Receive the white crosshatch or dot pattern from the service signal generator.
- (2) Use the 2 pieces of main 4-pole magnets of P/C magnets, change the open angle, and align the red and blue vertical lines on the screen center.
- (3) Freeze the open angle of the main 4-pole magnets, turn them simultaneously, and align the horizontal lines.
- (4) Take the same steps for items (2) and (3) above and align red/blue with green on the screen center using two 6-pole magnets.

(5) Adjust the sub-4-pole magnets only in case there is any deviation of Xv bow-shaped convergence. (To be usually set at the initial position)
Align both sides with the sub-4-pole magnets and minimize the deviation of blue and red with the main 4-pole magnets.

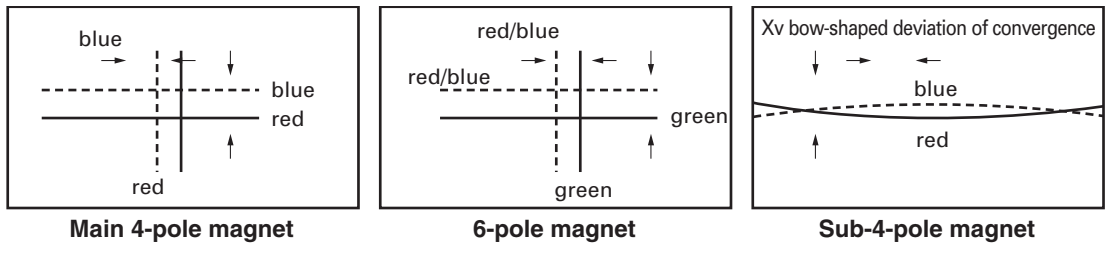

■ CIRCUMFERENCE CONVERGENCE:

* Perform correction in the following manner.

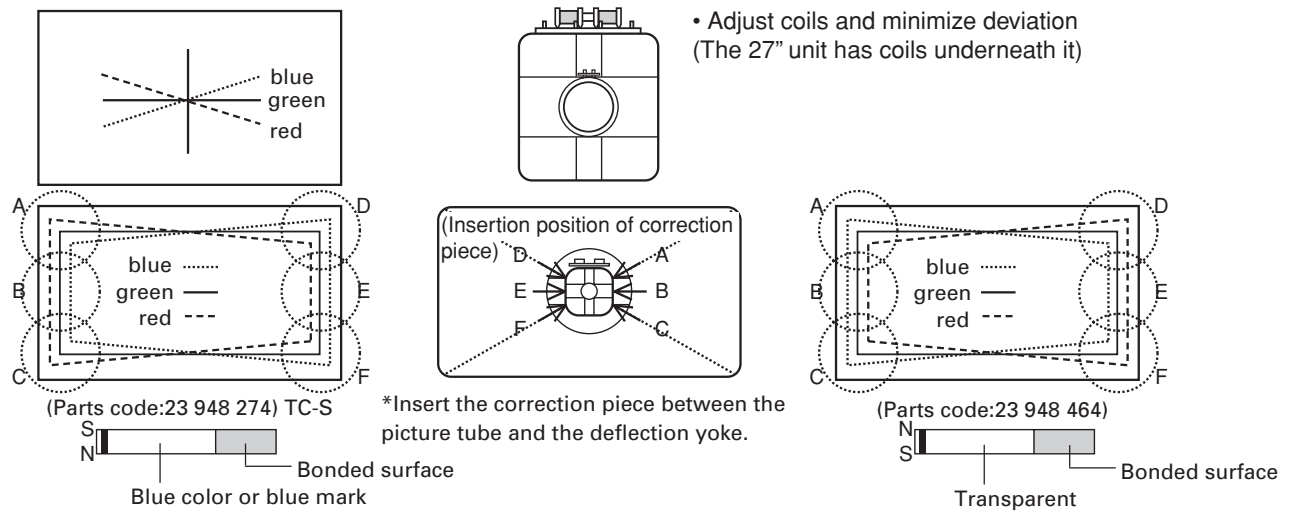

Adjust VR 1 and minimize the deviation of YH. *Only 27", 30" and 32".

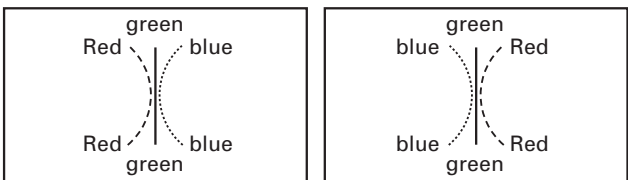

Adjust VR 2 (YHC) and minimize the deviation of YH.

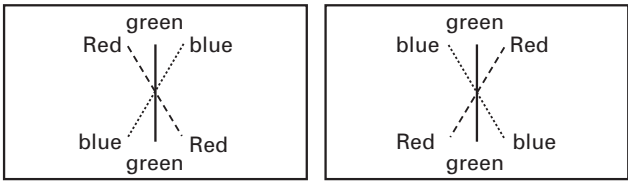

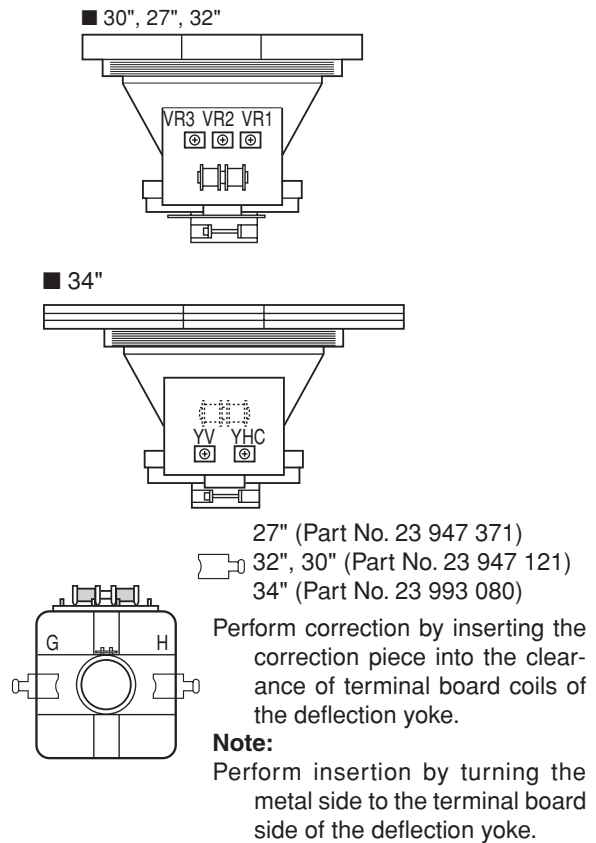
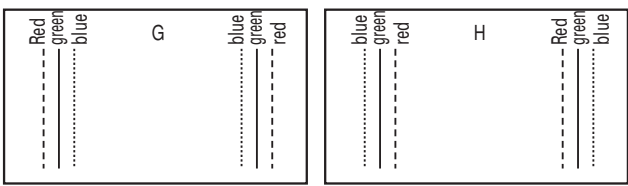
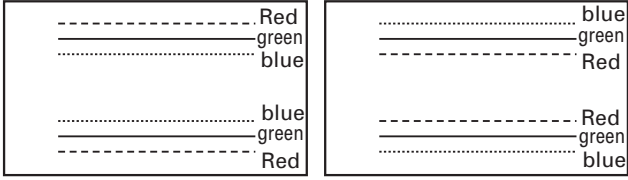

Adjust VR 3 (YV) and minimize the deviation of YV.



SERVICE MODE

1. ENTERING TO SERVICE MODE

- 1) Press  button once on Remote Control.
- 2) Press  button again to keep pressing.
- 3) While pressing the  button, press MENU button on TV.

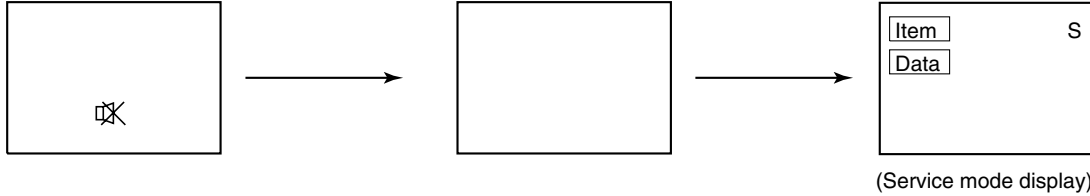





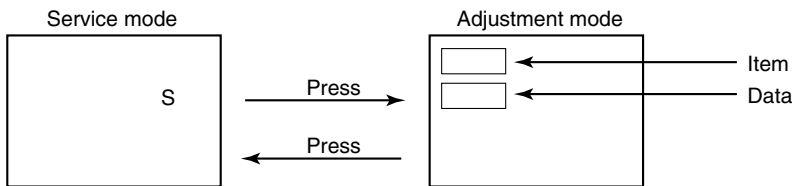

2. DISPLAYING THE ADJUSTMENT MENU

- 1) Press MENU button on TV.



3. KEY FUNCTION IN THE SERVICE MODE

The following key entry during display of adjustment menu provides special functions.

A single horizontal line ON/OFF :	- / - - button (on remote control)
Test signal ON/OFF :	 button (on TV or remote control)
Selection of the adjustment items :	Channel  /  (on TV or remote control)
Change of the data value :	Volume  +/- (on TV or remote control)
Adjustment menu mode ON/OFF :	MENU button (on TV)
Initialization of the memory (QA10) :	CALL + Channel button on TV ()
Reset the count of operating protect circuit to "00" :	CALL + Channel button on TV ()
"VG2" alignment :	0 button
"BCUT" selection :	1 button
"GCUT" selection :	2 button
"SCNT" selection :	4 button
"COLC" selection :	5 button - - - - - Color thickness correction
"TNTC" selection :	6 button
"SBY" selection :	7 button
Self diagnostic display ON/OFF :	9 button

note: Displayed differently as shown below, depending on the setting of the receiving color system.
COLP (PAL)
COLC (NTSC)
COLS (SECAM)

CAUTION : Never try to perform initialization unless you have changed the memory IC.

4. SELECTING THE ADJUSTING ITEMS

- 1) Every pressing of CH ▲ button in the service mode changes the adjustment items in the order of table-2.
(▼ button for reverse order)

Refer to table-2 for preset data of adjustment mode.
(See SETTING & ADJUSTING DATA on page 14)

5. ADJUSTING THE DATA

- 1) Pressing of ▲ +/- button will change the value of data in the range from 00H to FFH. The variable range depends on the adjusting item.

6. EXIT FROM SERVICE MODE

- 1) Pressing POWER button to turn off the TV once.

■ INITIALIZATION OF MEMORY DATA OF QA10

After replacing QA10, the following initialization is required.

1. Enter the service mode, then select any register item.
2. Press and hold the CALL button on the remote control, then press the CH ▲ button on the TV. The initialization of QA10 has been completed.
3. Check the picture carefully. If necessary, adjust any adjustment item above.
Perform "ASM function" on the owner's manual.

CAUTION: Never attempt to initialize the data unless QA10 has been replaced.

7. SELF DIAGNOSTIC FUNCTION

- 1) Press "9" button on the remote control during display of adjustment menu in the service mode.
The diagnosis will begin to check if interface among IC's are executed properly.
- 2) During diagnosis, the following displays are shown.

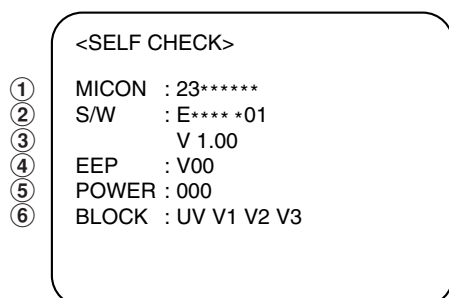

- ① Part number of microprocessor (QA51)
- ② Software type:
"ECMVT A01" ----- Software for Asian models.
"ERFAP R01" ----- Software for Russian models.
"ERFAP P01" ----- Software for Middle East models.
- ③ Software version
- ④ Memory IC data version
- ⑤ Protection circuit operation count
- ⑥ BLOCK
UV : TV reception mode
V1 : VIDEO 1 input mode (←1)
V2 : VIDEO 2 input mode (←2)
V3 : VIDEO 3 input mode (←3)

Indicated color of mode now selected : Green and Red
Indicated color of other modes : White

Green : Normal
Red : The microprocessor operates to provide judgement of no video signal.

- OTHERS : (1) In case that power indicator is blinking with interval of 0.5 seconds; it means protecting circuit (Current limiter) is operating, and circuit components may possibly be damaged. Check related components.
- (2) In case that power indicator is blinking with interval of 1 second; Protecting circuit does not operate, but a part of Bus line does not operate normally. Check Bus line.

DESIGN MODE

1. ENTERING TO DESIGN MODE

- 1) When in Service mode (see page 8), press CALL button on the remote control once.
- 2) While pressing CALL button again and press MENU button on the TV.
- 3) Press MENU button on TV.

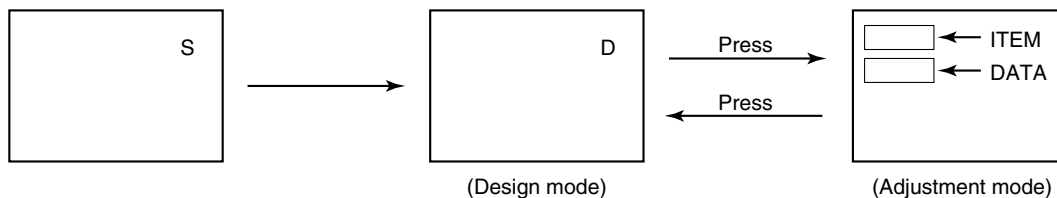

When QA10 is initialized, items “OPT”, “OPT1” and “OPT2” of DESIGN MODE are set to the data of the representative model of this chassis family.

Therefore, because ON-SCREEN specification remains in the state of the representative of model. This model is required to reset the data of items “OPT”, “OPT1” and “OPT2” according to current on-serviced model .

2. SELECTING THE ADJUSTING ITEMS

Every pressing of CH ▼ button in the design mode changes the adjustment items in the order of table-3.
(▲ button for reverse order)



Refer to table-3 for data of design mode.
(See SETTING & ADJUSTING DATA on page 14)

3. ADJUSTING THE DATA

Pressing of ▲ /+ buttons will change the value of data.

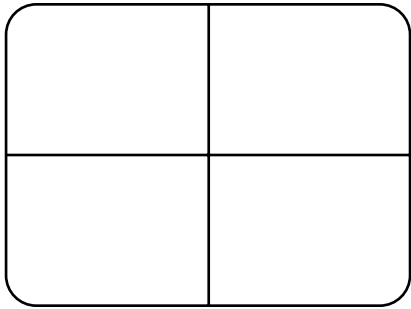
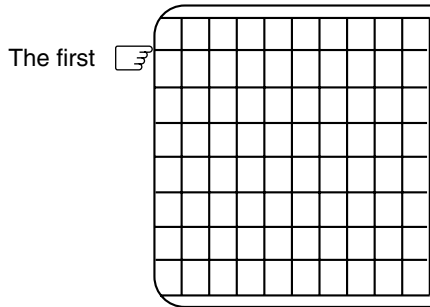
ELECTRICAL ADJUSTMENTS

ITEM	ADJUSTMENT PROCEDURE
<p>FOCUS VR ADJ</p>	<ol style="list-style-type: none"> 1. Enter the service mode, then input AV1 black cross-bar pattern with signal generator. 2. Adjust the FOCUS control (on T461) for well defined scanning lines on the picture screen.
<p>SUB-BRIGHTNESS (BRTC)</p>	<ol style="list-style-type: none"> 1. Input AV1 "5 steps pattern" with video signal generator. 2. Set CONTRAST to minimum and BRIGHTNESS to center by adjusting user controls. 3. Enter Service mode and press CH ▲/▼ to select BRTC. 4. Press ◀ -/+ buttons to adjust BRTC until step 0 and step 1 has the same blackness. 5. Exit service mode and press ⏻ button to set picture mode to DYNAMIC. 
<p>HORIZONTAL POSITION ADJUSTMENT (HPOS)</p> <p>VERTICAL POSITION ADJUSTMENT (VPOS)</p>	<ol style="list-style-type: none"> 1. Enter the service mode, input AV1 black or white cross-bar signal with signal generator. 2. Select either HPOS (Horizontal picture phase) or VPOS (Vertical picture phase) with CH ▲/▼ buttons, and adjust horizontal or vertical picture position in the center of screen with ◀ -/+ buttons. 
<p>VERTICAL AMPLITUDE ADJUSTMENT (HIT)</p>	<ol style="list-style-type: none"> 1. Enter the service mode, input AV1 black or white cross-hatch signal with signal generator. 2. Select HIT (Vertical amplitude) with CH ▲/▼ buttons, and adjust vertical amplitude with ◀ -/+ buttons so that vertical amplitude lacks a little. 3. Adjust vertical amplitude with ◀ -/+ buttons so that the first bar on cross-hatch signal touches edge of screen. 

ITEM	ADJUSTMENT PROCEDURE
<p>WHITE BALANCE ADJUSTMENT</p> <p>SCREEN VOLTAGE ADJUSTMENT (SCREEN VR) of FBT</p> <ul style="list-style-type: none"> • DRIVE ADJUSTMENT (GDRV) (BDRV) (RDRV) • CUTOFF ADJUSTMENT (GCUT) (BCUT) 	<ol style="list-style-type: none"> 1. Select AV1 (with no input). 2. Enter Service mode and press "0" button. 3. Adjust Screen VR until OSD "HBC" toggle between 1 & 0. 4. Press "0" button again to exit. 5. Input AV1 "5 steps pattern" with video signal generator. 6. Press  button to set picture mode to DYNAMIC. <p>※ To correct white balance in high light area (steps 3 and 4) select GDRV, BDRV and RDRV with  - /+ buttons.</p> <p>※ To correct white balance in low light area (steps 1 and 2), select GCUT and BCUT.</p> <div style="text-align: center;">  </div>

CIRCUIT CHECK

HIGH VOLTAGE CHECK

CAUTION: There is no HIGH VOLTAGE ADJUSTMENT on this chassis. Checking should be done following the steps below.

1. Connect an accurate high voltage meter to the second anode of the picture tube.
2. Turn on the receiver. Set the BRIGHTNESS and CONTRAST controls to minimum (zero beam current).
3. High voltage must be measured below (B) kV.

Refer to table-1 for high voltage (B).
(See SETTING & ADJUSTING DATA on page 14)

4. Vary the BRIGHTNESS control to both extremes to be sure the high voltage does not exceed the limit under any conditions.

CHAPTER 2 SPECIFIC INFORMATIONS

SETTING & ADJUSTING DATA

【 SAFETY INSTRUCTIONS 】

		29"
HIGH VOLTAGE AT MAX BEAM CURRENT:	(A)	30.0 kV
MAX HIGH VOLTAGE:	(B)	32.0 kV
AC VOLTAGE	(C)	110-240 V

Table-1

【 SERVICE MODE 】

ADJUSTING ITEMS AND DATAS IN THE SERVICE MODE:

Item	Adjustment	Reference Data	Adjust Data
BCUT	B CUTOFF (B/W)	20H	←
GCUT	G CUTOFF (B/W)	20H	←
RDRV	R DRIVE	20H	←
GDRV	G DRIVE	20H	←
BDRV	B DRIVE	20H	←
BRTC	SUB BRIGHT CENTER	24H	←
COLC	SUB COLOR CENTER NTSC	1EH	←
TNTC	SUB TINT CENTER	1EH	←
COLP	SUB COLOR CENTER PAL	1DH	←
COLS	SUB COLOR CENTER SECAM	1DH	←
SCNT	SUB CONTRAST TV	00H	←
SBY	SECAM B-Y BLACK OFFSET	01H	←
VPOS	50Hz V-POSITION	1CH	←
HIT	HEIGHT	25H	←
VLIN	V-LINEARITY	24H	←
HPOS	H-POSITION	2BH	←
WID	EW WIDTH	31H	←
PARA	EW PARABOLA	17H	←
TRAP	EW TRAPEZIUM	26H	←
TCNR	EW UPPER PARABOLA	15H	←
BCNR	EW LOWER PARABOLA	15H	←
HPLL	HORIZONTAL PARALLELOGRAM	22H	←
HBOW	HORIZONTAL BOW	20H	←
XCAL	CRYSTAL CALIBRATION	30H	←
RAGC	AGC TAKE-OVER	12H	←
CTR1	CONTROL 1	07H	←

Table-2

NAMES AND FUNCTIONS OF CONTROLS

Model 29CZ5DE is used in this manual for illustration purpose.

TV Front and Remote control

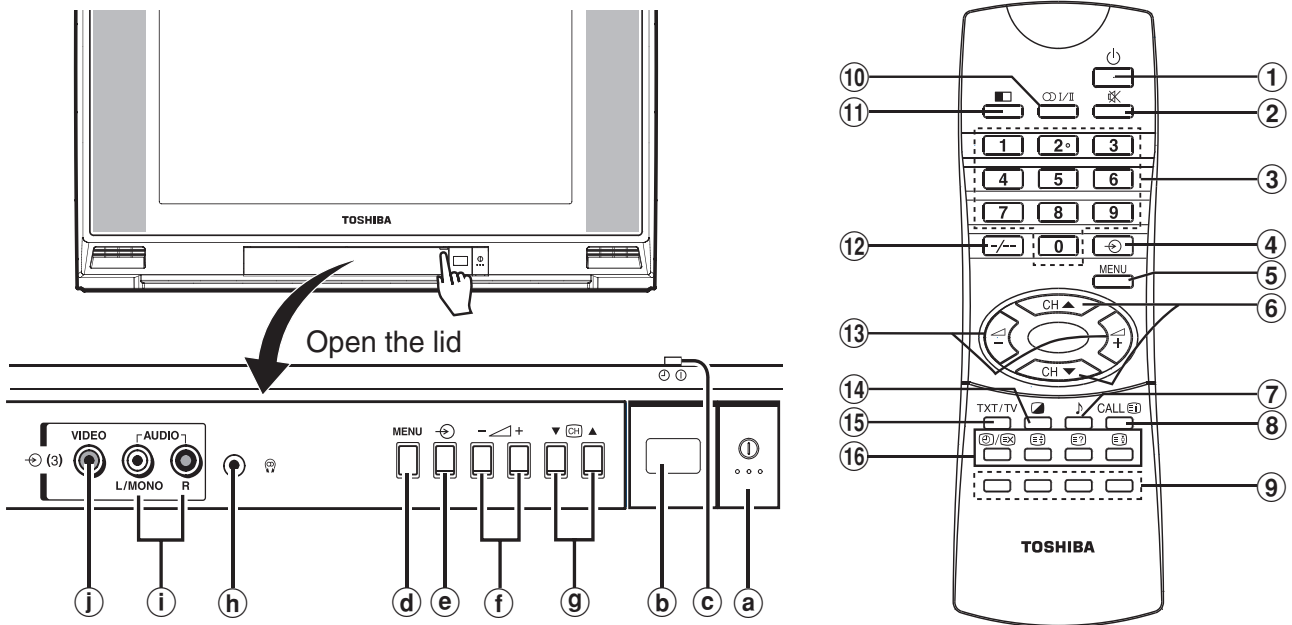

TV		Remote Control	
(a)	① Main power on/off	(1)	⏻ Power on/standby
(b)	① Remote sensor	(2)	🔇 Sound Mute, press again or ▲-/+ to restore the sound.
(c)	① Power indicator (red) Ⓢ Timer-ON indicator (green)	(3)	0~9 Number buttons
(d)	MENU Turn on menu display	(4)	⏪ Input source selection, Timer-ON position setting
(e)	⏪ Input source selection	(5)	MENU Turn on menu display
(f)	- ▲/+ Volume down/up, Menu selection or item adjust	(6)	CH ▲/▼ Channel up/down, Menu item selection
(g)	▼ CH ▲ Channel down/up, Menu item selection	(7)	🎵 Sound menu
(h)	🎧 Stereo headphones jack (Ø3.5mm) for private listening. The sound from the speakers will be cut off automatically.	(8)	CALL/☐ On-screen on/off, Turn off the menu, Teletext initial/index
(i)	AUDIO Audio input terminals	(9)	Teletext colored buttons Red/Green/Yellow/Blue
(j)	VIDEO Video input terminal	(10)	∞/II Stereo/bilingual selection
		(11)	☐ Double-window on/off
		(12)	-/-- Digit selection
		(13)	▲-/+ Volume down/up, Menu selection or item adjust
		(14)	☐ Picture menu
		(15)	TXT/TV Teletext/TV selection
		(16)	Teletext functions
			⌚/EX – Time display, To select a page while viewing a normal picture
			☐ – To enlarge teletext display size
			☐ – To reveal concealed text
			☐ – To hold a wanted page

PROGRAMMING CHANNEL MEMORY

Model 29CZ5DE is used in this manual for illustration purpose.

Preset the channels automatically (ASM function)

Use remote control for this operation. The buttons on the TV with similar name may also be use.

- 1 Select the starting position for channel to be preset. Press the Number buttons (-/+, 0-9) or CH ▲/▼.



- 2 Set the correct broadcast system for your region. Press **MENU** and then ▲ -/+ to highlight the "SET UP" icon.

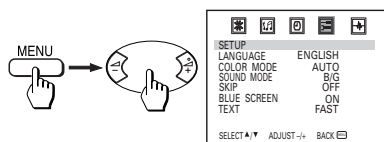

Confirm "COLOR MODE" is set to "AUTO" and "SOUND MODE" is set to proper system. If not, press CH ▲/▼ to select "COLOR MODE" or "SOUND MODE" and press ▲ -/+ to set each proper system.

- 3 Press **MENU** and then ▲ -/+ to highlight the "TUNING" icon. Select "ASM", then press ▲ + to start the search. When the TV screen returns to the start position, the procedure is complete.

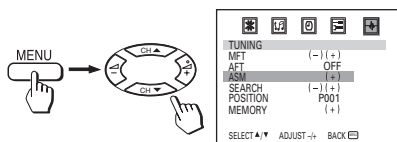

Presetting channel

- First, use the ASM (Automatic Search Memory) function to preset all active channels in your area automatically. Then, arrange the preset channels with the SEARCH, SKIP and MFT (Manual Fine Tuning) functions so that you can tune into only desired channels.
- Use the SEARCH function if desired channels cannot be preset with the ASM or if you would like to preset channels to specific position numbers one by one.

To use the SEARCH function

- 1 Press **MENU** and then ▲ -/+ to highlight the "TUNING" icon.

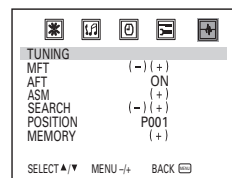

- 2 Press CH ▲/▼ to select "SEARCH". Press ▲ -/+ to start searching. Pressing "-" searches for channels at lower frequencies while pressing "+" searches for channels at higher frequencies. While searching, pressing the opposite direction button, + and - respectively, will cancel SEARCH function.

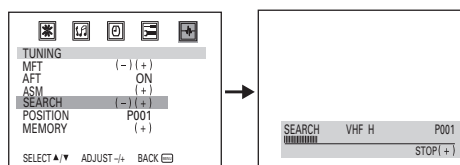

Repeat this process until you can get the desired channel.

- 3 When the desired channel is shown, press CH ▼ to select "POSITION". Press the ▲ -/+ buttons repeatedly until the position number to be preset is shown.

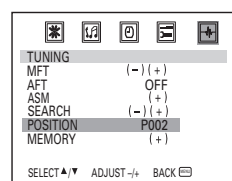

- 4 Press CH ▲/▼ to select "MEMORY", then press ▲ + to memorize the channel at the current position.

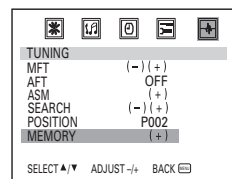

- 5 When you program other channels, repeat steps 2 to 4.

To skip a position number

After presetting the channels, you may skip unnecessary position numbers so that only the channels you want to watch are selected using **CH ▲/▼**.

- 1 First, select the position number to be skipped with **CH ▲/▼** or digit selection and number buttons (-/--, 0~9).
- 2 Highlight the **SET UP** icon and press **CH ▲/▼** to select "SKIP".

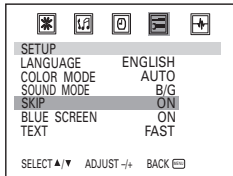

- 3 Press the **▲/▼** to set "SKIP" to "ON". This completes the setting for skipping the selected position number.

Notes

- When "SKIP" is set to "ON" for the selected position number, a "*" mark appears to the left of the position number.



The position number will then be skipped when you select the position with the **CH ▲/▼** buttons.

- If you want to restore a skipped position number, select it using the -/-- and 0~9 buttons then switch the "SKIP" setting to "OFF".

Manual fine tuning (MFT)

The adjustments below are not necessary under normal conditions. However, under some reception conditions, fine tuning may be necessary to improve the picture quality. In such cases, adjust the manual fine tuning (MFT).

- 1 Select the position number where the channel you want to fine-tune with **CH ▲/▼** or digit selection and number buttons (-/--, 0~9).
- 2 Press **MENU** and then **▲/▼** to highlight the **TUNING** icon.
- 3 Press **CH ▲/▼** to select "MFT". Press **▲/▼** to start fine tuning. Press **▲/▼** repeatedly until the best possible picture and sound are obtained.

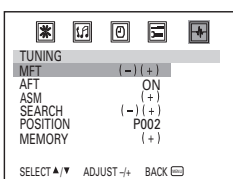

Auto fine tuning (AFT)

If the signal frequency is unstable due to environmental conditions, use auto fine tuning.

- 1 Select the position number where the channel you want to fine-tune with **CH ▲/▼** or the digit selection and number buttons (-/--, 0~9).

Note

When the position is set to "AFT OFF" status, the "■" mark appears to the left of the position number.



When the channel is set to "AFT ON" status, the position number is displayed without the "■" mark.

- 2 Press **MENU** then **▲/▼** to highlight the **TUNING** icon.
- 3 Press **CH ▲/▼** to select "AFT". Press **▲/▼** to select the "ON" indication.

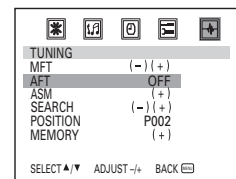

Notes

- When you operate MFT, AFT is switched "OFF" automatically. If you switch on AFT after fine tuning with MFT, MFT may be canceled.
- AFT may be set independently for each position.

PROCEDURES TO SET HOTEL MODE

1. Set the Channel Programs which you want the Customer to watch.

- 1) Use ASM (see page 16) or SEARCH (see page 16) to select the programs.
- 2) Choose the position you want the programs to be stored in TUNING menu.
- 3) Save the programs by MEMORY operation in TUNING menu (see page 16).

2. Set the Channels which you don't want the Customer to access

- 1) Select the channel by pressing the number buttons or CH ▲/▼ buttons.
- 2) Set the SKIP from OFF to ON (see page 17).
- 3) Repeat above 1) & 2) for all the channels which need to be blocked.



3. Activate the HOTEL Mode:

- 1) Select startup channel (TV, video input 1, 2/DVD, or 3) first, then enter into design mode (see page 11).
- 2) In Design Mode (see page 11), press CH ▼ button on the remote controller to show the Design Item "OPT1".
- 3) Add "0x80" to the data of "OPT1" to activate the HOTEL Mode with panel buttons unlocked, or add "0xC0" to the data of "OPT1" to activate the HOTEL Mode with panel buttons locked.
- 4) Turn off the TV once and turn it on again, the TV will be in HOTEL Mode with all the customer settings taking effect.

4. Set the maximum volume:

- 1) Enter Service Mode (see page 8).
- 2) Enter Design Mode (see page 11).
- 3) Use the CH ▼ button on the remote controller to show the Design Item "VOLX".
- 4) Adjust the "VOLX" data by pressing ◀+/- buttons (Default 0x1E is equal to Volume 30 in Decimal).

5. Set the following items in HOTEL Mode:

- 1) Picture mode
Press  button to select the desired picture quality. "DYNAMIC", "STANDARD", "MILD" and "MEMORY" will appear cyclically.
- 2) Sound mode
Press  button to select the desired sound quality. "THEATER", "NEWS" and "MEMORY" will appear cyclically.
(Every time turning on the TV will call back the above customer setting.)

CHASSIS AND CABINET REPLACEMENT PARTS LIST

WARNING: BEFORE SERVICING THIS CHASSIS, READ THE “X-RAY RADIATION PRECAUTION”, “SAFETY PRECAUTION” AND “PRODUCT SAFETY NOTICE” ON PAGE 3 OF THIS MANUAL.

CAUTION: The international hazard symbols “⚠” in the schematic diagram and the parts list designate components which have special characteristics important for safety and should be replaced only with types identical to those in the original circuit or specified in the parts list. The mounting position of replacements is to be identical with originals. Before replacing any of these components, read carefully the PRODUCT SAFETY NOTICE. Do not degrade the safety of the receiver through improper servicing.

NOTICE:

- The part number must be used when ordering parts, in order to assist in processing, be sure to include the Model number and Description.
- The PC board assembly with * mark is no longer available after the end of the production.

Model: 29CZ5DE/29CZ5T/29CZ6SI

Capacitors CD	: Ceramic Disk	PF	: Plastic Film	EL	: Electrolytic	
Resistors CF	: Carbon Film	CC	: Carbon Composition	MF	: Metal Film	
	OMF	: Oxide Metal Film	VR	: Variable Resistor	FR	: Fusible Resistor

(All CD and PF capacitors are ±5%, 50V and all resistors, ±5%, 1/6W unless otherwise noted.)

Location No.	Parts No.	Description
[#1: 29CZ5DE]		
[#2: 29CZ5T]		
[#3: 29CZ6SI]		
CAPACITORS		
C101	76797479	ELECTROLYTIC 50V 4.7UF M
C102	76109103	CERAMIC CHIP 50V B 0.01UF K
C103	76109103	CERAMIC CHIP 50V B 0.01UF K
C104	#1 76109103	CERAMIC CHIP 50V B 0.01UF K
	#3 76109103	CERAMIC CHIP 50V B 0.01UF K
C105	76109103	CERAMIC CHIP 50V B 0.01UF K
C106	76109103	CERAMIC CHIP 50V B 0.01UF K
C107	76109102	CERAMIC CHIP 50V B 1000PF K
C108	76797100	ELECTROLYTIC 50V 10UF M
C109	76797221	ELECTROLYTIC 50V 220UF M
C110	76797221	ELECTROLYTIC 50V 220UF M
C114	76109103	CERAMIC CHIP 50V B 0.01UF K
C116	76109103	CERAMIC CHIP 50V B 0.01UF K
C121	76797100	ELECTROLYTIC 50V 10UF M
C122	76100104	CERAMIC CHIP 25V F 0.1UF Z
C123	76109332	CERAMIC CHIP 50V B 3300PF K
C124	76100104	CERAMIC CHIP 25V F 0.1UF Z
C125	76797229	ELECTROLYTIC 50V 2.2UF M
C127	76797229	ELECTROLYTIC 50V 2.2UF M
C128	76100104	CERAMIC CHIP 25V F 0.1UF Z
C129	76793471	ELECTROLYTIC 10V 470UF M
C131	76109103	CERAMIC CHIP 50V B 0.01UF K
C140	#2 76000445	CHIP JUMPER 1608TYPE
C141	#2 76109103	CERAMIC CHIP 50V B 0.01UF K
C142	#2 76109103	CERAMIC CHIP 50V B 0.01UF K
C144	#2 76797100	ELECTROLYTIC 50V 10UF M
C145	#2 76100104	CERAMIC CHIP 25V F 0.1UF Z
C156	76105120	CERAMIC CHIP 50V CH 12PF J
C157	76105510	CERAMIC CHIP 50V CH 51PF J
C158	76797100	ELECTROLYTIC 50V 10UF M
C159	76100104	CERAMIC CHIP 25V F 0.1UF Z
C201	76109682	CERAMIC CHIP 50V B 6800PF K
C202	76125006	E. CAP 25V 1.5UF REA1R5K1EFC-0511
C203	76503045	PLASTIC FILM 63V 0.22UF J
C204	76795100	ELECTROLYTIC 25V 10UF M
C205	76109223	CERAMIC CHIP 25V B 0.022UF K
C206	76100104	CERAMIC CHIP 25V F 0.1UF Z
C211	76100104	CERAMIC CHIP 25V F 0.1UF Z
C212	76206010	ELECTROLYTIC 50V 1.0UF M 7L 3A
C219	76092729	CERAMIC CHIP 16V B 0.068UF K
C220	76503047	PLASTIC FILM 63V 0.33UF J
C303	76214471	CERAMIC DISC 500V B 470PF K
C308	76669221	ELECTROLYTIC 50V 220UF M

Location No.	Parts No.	Description
C309	76667102	ELECTROLYTIC 25V 1000UF M
C310	76667222	ELECTROLYTIC 25V 2200UF M 3A
C313	76082061	PLASTIC FILM 100V 0.47UF J
C315	76109102	CERAMIC CHIP 50V B 1000PF K
C321	76109272	CERAMIC CHIP 50V B 2700PF K
C322	76214471	CERAMIC DISC 500V B 470PF K
C327	76100102	CERAMIC CHIP 50V F 1000PF Z
C328	76693104	PLASTIC FILM 100V 0.1UF J
C329	76100102	CERAMIC CHIP 50V F 1000PF Z
C331	76109472	CERAMIC CHIP 50V B 4700PF K
C333	76667222	ELECTROLYTIC 25V 2200UF M 3A
C335	76667221	ELECTROLYTIC 25V 220UF M
C336	76109272	CERAMIC CHIP 50V B 2700PF K
C350	76503043	PLA CAP PCMT36676154
C363	76693104	PLASTIC FILM 100V 0.1UF J
C401	76105151	CERAMIC CHIP 50V CH 150PF J
C402	76693472	PLASTIC FILM 100V 4700PF J
C413	76214821	CERAMIC DISC 500V B 820PF K
C416	76678479	ELECTROLYTIC 200V 4.7UF M
C417	76214391	CERAMIC DISC 500V B 390PF K
C430	76092731	CERAMIC CHIP 16V B 1UF K
C432	76100102	CERAMIC CHIP 50V F 1000PF Z
C435	76794220	ELECTROLYTIC 16V 22UF M
C439	76503125	PLASTIC FILM 400V 0.075UF J
C442	76503298	PLASTIC FILM 315V 0.3UF J
C443	76503194	PLASTIC FILM 1500VH 0.01UF H
C444	76503228	PLASTIC FILM 1500VH 6800PF H
C447	76679220	ELECTROLYTIC 250V 22UF M 3A
C448	76640908	ELECTROLYTIC 160V 33UF M 3A LI
C449	76667102	ELECTROLYTIC 25V 1000UF M
C463	76212222	CERAMIC DISC 50V B 2200PF K
C464	76073124	ELECTROLYTIC 100V 10UF M
C467	76503159	PLASTIC FILM 630V 0.039UF J
C470	76766101	ELECTROLYTIC 50V 100UF M
C4700	76109332	CERAMIC CHIP 50V B 3300PF K
C4703	76764221	ELECTROLYTIC 25V 220UF M
C4712	76109332	CERAMIC CHIP 50V B 3300PF K
C4717	76000445	CHIP JUMPER 1608TYPE
C472	76503049	PLASTIC FILM 63V 0.47UF J
C475	76100103	CERAMIC CHIP 50V F 0.01UF Z
C501	76793471	ELECTROLYTIC 10V 470UF M
C502	76092730	CERAMIC CHIP 16V B 0.1UF K
C503	76203100	ELECTROLYTIC 16V 10UF M 7L 3A
C504	76100104	CERAMIC CHIP 25V F 0.1UF Z
C505	76793471	ELECTROLYTIC 10V 470UF M
C506	76100104	CERAMIC CHIP 25V F 0.1UF Z
C507	76793471	ELECTROLYTIC 10V 470UF M
C508	76100104	CERAMIC CHIP 25V F 0.1UF Z

SPECIFIC INFORMATIONS

Location No.	Parts No.	Description
C509	76109561	CERAMIC CHIP 50V B 560PF K
C510	76105220	CERAMIC CHIP 50V CH 22PF J
C511	76105220	CERAMIC CHIP 50V CH 22PF J
C512	76105220	CERAMIC CHIP 50V CH 22PF J
C660	76206010	ELECTROLYTIC 50V 1.0UF M 7L 3A
C662	76109102	CERAMIC CHIP 50V B 1000PF K
C663	76797229	ELECTROLYTIC 50V 2.2UF M
C664	76206010	ELECTROLYTIC 50V 1.0UF M 7L 3A
C666	76109102	CERAMIC CHIP 50V B 1000PF K
C667	76797229	ELECTROLYTIC 50V 2.2UF M
C671	76763471	ELECTROLYTIC 16V 470UF M
C672	76203470	ELECTROLYTIC 16V 47UF M 7L 3A
C681	76765102	ELECTROLYTIC 35V 1000UF M
C682	76765102	ELECTROLYTIC 35V 1000UF M
C683	76765102	ELECTROLYTIC 35V 1000UF M
C684	76203470	ELECTROLYTIC 16V 47UF M 7L 3A
C686	76092883	CERAMIC CHIP 50V B 0.1UF K
C687	76092883	CERAMIC CHIP 50V B 0.1UF K
C690	76766101	ELECTROLYTIC 50V 100UF M
C704	76591822	PLASTIC FILM 50V 8200PF J
C705	76232103	CERAMIC DISC 50V F 0.01UF Z
C707	76795470	ELECTROLYTIC 25V 47UF M
C712	76795470	ELECTROLYTIC 25V 47UF M
C713	76709100	ELECTROLYTIC 200V 10UF M
C714	76436101	CERAMIC DISC 50V SL 100PF J
C715	76214472	CERAMIC DISC 500V B 4700PF K
C716	76436101	CERAMIC DISC 50V SL 100PF J
C717	76214472	CERAMIC DISC 500V B 4700PF K
C718	76794470	ELECTROLYTIC 16V 47UF M
C719	76435560	CERAMIC DISC 500V SL 56PF J
C720	76709100	ELECTROLYTIC 200V 10UF M
C721	76794470	ELECTROLYTIC 16V 47UF M
C722	76436561	CERAMIC DISC 50V SL 560PF J
C726	76212102	CERAMIC DISC 50V B 1000PF K
△ C801	76503507	PLASTIC FILM AC275V 0.22UF K
△ C802	76503507	PLASTIC FILM AC275V 0.22UF K
C805	76092281	CERAMIC DISC AC250V E 4700PF
C806	76092281	CERAMIC DISC AC250V E 4700PF
C808	76794222	ELECTROLYTIC 16V 2200UF M
C809	76797479	ELECTROLYTIC 50V 4.7UF M
C810	76086857	ELECTROLYTIC 400V 560UF
△ C811	76166021	CERA CAP E 250V 102 DE1E3KX102MB4BL01
△ C812	76166021	CERA CAP E 250V 102 DE1E3KX102MB4BL01
△ C813	76166021	CERA CAP E 250V 102 DE1E3KX102MB4BL01
△ C814	76166021	CERA CAP E 250V 102 DE1E3KX102MB4BL01
△ C815	76166021	CERA CAP E 250V 102 DE1E3KX102MB4BL01
C817	76092347	CERAMIC DISC 2KV R 1500PF K
C818	76105471	CERAMIC CHIP 50V CH 470PF J
C820	76591473	PLASTIC FILM 50V 0.047UF J
C821	76797470	ELECTROLYTIC 50V 47UF M
C823	76105221	CERAMIC CHIP 50V CH 220PF J
C824	76109182	CERAMIC CHIP 50V B 1800PF K
C830	76212103	CERAMIC DISC 50V B 0.01UF K
C831	76794101	ELECTROLYTIC 16V 100UF M
C832	76794101	ELECTROLYTIC 16V 100UF M
C833	76212103	CERAMIC DISC 50V B 0.01UF K
C834	76794101	ELECTROLYTIC 16V 100UF M
C836	76794102	ELECTROLYTIC 16V 1000UF M
C837	76794101	ELECTROLYTIC 16V 100UF M
C838	76503047	PLASTIC FILM 63V 0.33UF J
C839	76503047	PLASTIC FILM 63V 0.33UF J
C841	76503047	PLASTIC FILM 63V 0.33UF J
C842	76503047	PLASTIC FILM 63V 0.33UF J
C843	76794101	ELECTROLYTIC 16V 100UF M
C848	76212103	CERAMIC DISC 50V B 0.01UF K
C849	76794101	ELECTROLYTIC 16V 100UF M
C884	76086052	ELECTROLYTIC 200V 220UF M 22A
C885	76214471	CERAMIC DISC 500V B 470PF K
C888	76105471	CERAMIC CHIP 50V CH 470PF J
C889	76796222	ELECTROLYTIC 35V 2200UF M
C890	76796222	ELECTROLYTIC 35V 2200UF M
C891	76763471	ELECTROLYTIC 16V 470UF M
C892	76214471	CERAMIC DISC 500V B 470PF K
C893	76092337	CERAMIC DISC 2KV 220PF K
C894	76214471	CERAMIC DISC 500V B 470PF K
C895	76796332	ELECTROLYTIC 35V 3300UF M
C896	76668331	ELECTROLYTIC 35V 330UF M 3A
C897	76214471	CERAMIC DISC 500V B 470PF K
C898	76503045	PLASTIC FILM 63V 0.22UF J

Location No.	Parts No.	Description
C899	76214471	CERAMIC DISC 500V B 470PF K
C901	76214103	CERAMIC DISC 500V B 0.01UF K
C902	76092353	CERAMIC DISC 2KV 4700PF K
C903	76168053	PLASTIC FILM 540)400V 134J 4-20
C904	76679100	ELECTROLYTIC 250V 10UF M 3A
C909	76679100	ELECTROLYTIC 250V 10UF M 3A
C910	76206478	ELECTROLYTIC 50V 0.47UF M 7L 3A
C911	76206478	ELECTROLYTIC 50V 0.47UF M 7L 3A
C912	76763471	ELECTROLYTIC 16V 470UF M
C931	76214101	CERAMIC DISC 500V B 100PF K
CA01	76203100	ELECTROLYTIC 16V 10UF M 7L 3A
CA03	76092734	CERAMIC CHIP 16V F 0.22UF Z
CA04	76092734	CERAMIC CHIP 16V F 0.22UF Z
CA05	76092730	CERAMIC CHIP 16V B 0.1UF K
CA06	76793101	ELECTROLYTIC 10V 100UF M
CA101	76092734	CERAMIC CHIP 16V F 0.22UF Z
CA108	76105680	CERAMIC CHIP 50V CH 68PF J
CA109	76105680	CERAMIC CHIP 50V CH 68PF J
CA110	76092734	CERAMIC CHIP 16V F 0.22UF Z
CA112	76795100	ELECTROLYTIC 25V 10UF M
CA116	76092734	CERAMIC CHIP 16V F 0.22UF Z
CA117	76797221	ELECTROLYTIC 50V 220UF M
CA118	76092730	CERAMIC CHIP 16V B 0.1UF K
CA119	76797229	ELECTROLYTIC 50V 2.2UF M
CA120	76100103	CERAMIC CHIP 50V F 0.01UF Z
CA124	76092734	CERAMIC CHIP 16V F 0.22UF Z
CA14	76795100	ELECTROLYTIC 25V 10UF M
CA30	76100104	CERAMIC CHIP 25V F 0.1UF Z
CA31	76100104	CERAMIC CHIP 25V F 0.1UF Z
CA88	76092734	CERAMIC CHIP 16V F 0.22UF Z
CA89	76793101	ELECTROLYTIC 10V 100UF M
CA90	76092734	CERAMIC CHIP 16V F 0.22UF Z
CA91	76092730	CERAMIC CHIP 16V B 0.1UF K
CA92	76793101	ELECTROLYTIC 10V 100UF M
CA93	76092734	CERAMIC CHIP 16V F 0.22UF Z
CA94	76793101	ELECTROLYTIC 10V 100UF M
CA95	76092730	CERAMIC CHIP 16V B 0.1UF K
CA96	76092734	CERAMIC CHIP 16V F 0.22UF Z
CA97	76100103	CERAMIC CHIP 50V F 0.01UF Z
CA98	76105680	CERAMIC CHIP 50V CH 68PF J
CA99	76105680	CERAMIC CHIP 50V CH 68PF J
CB07	76203100	ELECTROLYTIC 16V 10UF M 7L 3A
CB21	76794470	ELECTROLYTIC 16V 47UF M
CC01	76109103	CERAMIC CHIP 50V B 0.01UF K
CC02	76109102	CERAMIC CHIP 50V B 1000PF K
CC03	76109102	CERAMIC CHIP 50V B 1000PF K
CC04	76109102	CERAMIC CHIP 50V B 1000PF K
CC05	76109102	CERAMIC CHIP 50V B 1000PF K
CC06	76109102	CERAMIC CHIP 50V B 1000PF K
CC14	76109103	CERAMIC CHIP 50V B 0.01UF K
CC17	76212102	CERAMIC DISC 50V B 1000PF K
CC18	76212102	CERAMIC DISC 50V B 1000PF K
CC20	#1 76105150	CERAMIC CHIP 50V CH 15PF J
CS01	76203100	ELECTROLYTIC 16V 10UF M 7L 3A
CS02	76203100	ELECTROLYTIC 16V 10UF M 7L 3A
CS03	76794220	ELECTROLYTIC 16V 22UF M
CS04	76100103	CERAMIC CHIP 50V F 0.01UF Z
CS05	76206478	ELECTROLYTIC 50V 0.47UF M 7L 3A
CS06	76206478	ELECTROLYTIC 50V 0.47UF M 7L 3A
CS07	76206478	ELECTROLYTIC 50V 0.47UF M 7L 3A
CS08	76206478	ELECTROLYTIC 50V 0.47UF M 7L 3A
CS09	76206478	ELECTROLYTIC 50V 0.47UF M 7L 3A
CS10	76206478	ELECTROLYTIC 50V 0.47UF M 7L 3A
CS11	76206478	ELECTROLYTIC 50V 0.47UF M 7L 3A
CS12	76105470	CERAMIC CHIP 50V CH 47PF J
CS13	76105470	CERAMIC CHIP 50V CH 47PF J
CS14	76105470	CERAMIC CHIP 50V CH 47PF J
CS15	76105470	CERAMIC CHIP 50V CH 47PF J
CS16	76105470	CERAMIC CHIP 50V CH 47PF J
CS17	76105470	CERAMIC CHIP 50V CH 47PF J
CS18	76105470	CERAMIC CHIP 50V CH 47PF J
CS19	76105470	CERAMIC CHIP 50V CH 47PF J
CS20	76105470	CERAMIC CHIP 50V CH 47PF J
CS21	76105470	CERAMIC CHIP 50V CH 47PF J
CS22	76105470	CERAMIC CHIP 50V CH 47PF J
CS23	76105470	CERAMIC CHIP 50V CH 47PF J
CV06	76762471	ELECTROLYTIC 10V 470UF M
CV08	76795470	ELECTROLYTIC 25V 47UF M
CV09	76100104	CERAMIC CHIP 25V F 0.1UF Z

Location No.	Parts No.	Description
CV10	76100104	CERAMIC CHIP 25V F 0.1UF Z
CV11	76100104	CERAMIC CHIP 25V F 0.1UF Z
CV12	76100103	CERAMIC CHIP 50V F 0.01UF Z
CV13	76100104	CERAMIC CHIP 25V F 0.1UF Z
CV14	76100104	CERAMIC CHIP 25V F 0.1UF Z
CV15	76100104	CERAMIC CHIP 25V F 0.1UF Z
CV16	76105101	CERAMIC CHIP 50V CH 100PF J
CV17	76105101	CERAMIC CHIP 50V CH 100PF J
CV18	76105101	CERAMIC CHIP 50V CH 100PF J
CV19	76105101	CERAMIC CHIP 50V CH 100PF J
CV20	76105101	CERAMIC CHIP 50V CH 100PF J
CV21	76109102	CERAMIC CHIP 50V B 1000PF K
CV22	76109102	CERAMIC CHIP 50V B 1000PF K
CV25	76212101	CERAMIC DISC 50V B 100PF K
Z154	23303166	CERAMIC TRAP 39.5MHZ TCF1107
Z155	23303224	CERAMIC TRAP TCF1120AM
RESISTORS		
G714	76545220	FUSIBLE 1/4W 22 OHM J
GJ01	76011472	CHIP 1/20W 4.7K OHM J
GJ02	76011472	CHIP 1/20W 4.7K OHM J
GJ03	76000445	CHIP JUMPER 1608TYPE
GJ05	76000445	CHIP JUMPER 1608TYPE
GJ401	76000445	CHIP JUMPER 1608TYPE
GJ808	76000445	CHIP JUMPER 1608TYPE
GJ811	76000445	CHIP JUMPER 1608TYPE
GR001	76000445	CHIP JUMPER 1608TYPE
GR828	76366221	CARBON FILM 1/6W 220 OHM J
JR001	76000445	CHIP JUMPER 1608TYPE
JR002	76000445	CHIP JUMPER 1608TYPE
JR003	76000445	CHIP JUMPER 1608TYPE
JR004	76000445	CHIP JUMPER 1608TYPE
JR005	76000445	CHIP JUMPER 1608TYPE
JR006	76000445	CHIP JUMPER 1608TYPE
JR007	76000445	CHIP JUMPER 1608TYPE
JR008	76000445	CHIP JUMPER 1608TYPE
JR009	76000445	CHIP JUMPER 1608TYPE
JR010	76000445	CHIP JUMPER 1608TYPE
JR011	76000445	CHIP JUMPER 1608TYPE
JR013	76000445	CHIP JUMPER 1608TYPE
JR014	76000445	CHIP JUMPER 1608TYPE
JR016	76000445	CHIP JUMPER 1608TYPE
JR017	76000445	CHIP JUMPER 1608TYPE
JR018	76000445	CHIP JUMPER 1608TYPE
JR019	76000445	CHIP JUMPER 1608TYPE
LC04	76366101	CARBON FILM 1/6W 100 OHM J
LC05	76366101	CARBON FILM 1/6W 100 OHM J
LC06	76000445	CHIP JUMPER 1608TYPE
LC07	76000445	CHIP JUMPER 1608TYPE
LC08	76000445	CHIP JUMPER 1608TYPE
LC09	76000445	CHIP JUMPER 1608TYPE
LC10	76000445	CHIP JUMPER 1608TYPE
LC11	76000445	CHIP JUMPER 1608TYPE
LC12	76000445	CHIP JUMPER 1608TYPE
LC13	76000445	CHIP JUMPER 1608TYPE
LC14	76000445	CHIP JUMPER 1608TYPE
LC15	76000445	CHIP JUMPER 1608TYPE
LC16	76000445	CHIP JUMPER 1608TYPE
LC17	76000445	CHIP JUMPER 1608TYPE
R101	76011330	CHIP 1/20W 33 OHM J
R102	76011682	CHIP 1/20W 6.8K OHM J
R103	76011272	CHIP 1/20W 2.7K OHM J
R104	76011330	CHIP 1/20W 33 OHM J
R105	76011751	CHIP 1/20W 750 OHM J
R106	76011330	CHIP 1/20W 33 OHM J
R107	76366390	CARBON FILM 1/6W 39 OHM J
R108	76011821	CHIP 1/20W 820 OHM J
R109	76011102	CHIP 1/20W 1K OHM J
R110	#1 76366103	CARBON FILM 1/6W 10K OHM J
	#3 76366103	CARBON FILM 1/6W 10K OHM J
R111	#1 76011302	CHIP 1/20W 3K OHM J
	#3 76011302	CHIP 1/20W 3K OHM J
R112	#1 76011103	CHIP 1/20W 10K OHM J
	#3 76011103	CHIP 1/20W 10K OHM J
R113	#1 76011332	CHIP 1/20W 3.3K OHM J
	#3 76011332	CHIP 1/20W 3.3K OHM J
R115	76011102	CHIP 1/20W 1K OHM J
R116	76011101	CHIP 1/20W 100 OHM J
R117	#1 76366153	CARBON FILM 1/6W 15K OHM J

Location No.	Parts No.	Description
R117	#3 76366153	CARBON FILM 1/6W 15K OHM J
R118	#1 76011101	CHIP 1/20W 100 OHM J
	#3 76011101	CHIP 1/20W 100 OHM J
R119	76000445	CHIP JUMPER 1608TYPE
R121	76011471	CHIP 1/20W 470 OHM J
R122	76011391	CHIP 1/20W 390 OHM J
R124	76011123	CHIP 1/20W 12K OHM J
R125	76011563	CHIP 1/20W 56K OHM J
R126	76011681	CHIP 1/20W 680 OHM J
R140	#2 76011101	CHIP 1/20W 100 OHM J
R141	#2 76011222	CHIP 1/20W 2.2K OHM J
R142	#2 76011221	CHIP 1/20W 220 OHM J
R152	76011331	CHIP 1/20W 330 OHM J
R156	76553153	OXIDE METAL FILM 1W 15K OHM J
R201	76011123	CHIP 1/20W 12K OHM J
R215	76366203	CARBON FILM 1/6W 20K OHM J
R216	76366103	CARBON FILM 1/6W 10K OHM J
R217	76366203	CARBON FILM 1/6W 20K OHM J
R218	76366332	CARBON FILM 1/6W 3.3K OHM J
R219	76011224	CHIP 1/20W 220K OHM J
R227	76366272	CARBON FILM 1/6W 2.7K OHM J
R228	76011103	CHIP 1/20W 10K OHM J
R303	76170001	OXIDE R 109J RS1BSJHD109
R305	76322159	OXIDE METAL FILM 1W 1.5 OHM J
R314	76011473	CHIP 1/20W 47K OHM J
R318	76011102	CHIP 1/20W 1K OHM J
R320	76011101	CHIP 1/20W 100 OHM J
R321	76011103	CHIP 1/20W 10K OHM J
R322	76182030	METAL R ERX1FJ4R7H
R324	76011472	CHIP 1/20W 4.7K OHM J
R325	76011101	CHIP 1/20W 100 OHM J
R327	76182030	METAL R ERX1FJ4R7H
R328	76011682	CHIP 1/20W 6.8K OHM J
R329	76011682	CHIP 1/20W 6.8K OHM J
R331	76366562	CARBON FILM 1/6W 5.6K OHM J
R336	76383221	OXIDE METAL FILM 2W 220 OHM J
R346	76000445	CHIP JUMPER 1608TYPE
R347	76011103	CHIP 1/20W 10K OHM J
R348	76011562	CHIP 1/20W 5.6K OHM J
R350	76367393	CARBON FILM 1/6W 39K OHM J
R354	76011223	CHIP 1/20W 22K OHM J
R363	76552181	OXIDE METAL FILM 1/2W 180 OHM J
R401	76011105	CHIP 1/20W 1M OHM J
R403	76382472	OXIDE METAL FILM 1W 4.7K OHM J
R409	76011123	CHIP 1/20W 12K OHM J
R412	76011472	CHIP 1/20W 4.7K OHM J
R413	76000445	CHIP JUMPER 1608TYPE
R415	76553272	OXIDE METAL FILM 1W 2.7K OHM J
R416	76019332	OXIDE METAL FILM 5W 4.3K OHM J
R419	76011183	CHIP 1/20W 18K OHM J
R420	76011102	CHIP 1/20W 1K OHM J
R4200	76011101	CHIP 1/20W 100 OHM J
R424	76011103	CHIP 1/20W 10K OHM J
R425	76011103	CHIP 1/20W 10K OHM J
R426	76011101	CHIP 1/20W 100 OHM J
R429	76552560	OXIDE METAL FILM 1/2W 56 OHM J
R431	76011101	CHIP 1/20W 100 OHM J
R435	76011562	CHIP 1/20W 5.6K OHM J
R437	76000445	CHIP JUMPER 1608TYPE
R438	76366823	CARBON FILM 1/6W 82K OHM J
R439	76366222	CARBON FILM 1/6W 2.2K OHM J
R440	76011471	CHIP 1/20W 470 OHM J
R441	76532102	FUSIBLE 1W 1K OHM J
R448	76182049	METAL OXIDE 9.1 OHM ERX1FJ9R1H
R462	76322229	OXIDE METAL FILM 1W 2.2 OHM J
R470	76182018	METAL R ERX1FJR47H
R4704	76011104	CHIP 1/20W 100K OHM J
R471	76381131	OXIDE METAL FILM 1/2W 130 OHM J
R4716	76011393	CHIP 1/20W 39K OHM J
R4717	76011824	CHIP 1/20W 820K OHM J
R4718	76011273	CHIP 1/20W 27K OHM J
R473	76000247	METAL FILM 1/4W 39K OHM F
R4760	76000242	METAL FILM 1/4W 18K OHM F
R4770	76011102	CHIP 1/20W 1K OHM J
R479	76381271	OXIDE METAL FILM 1/2W 270 OHM J
R501	76011103	CHIP 1/20W 10K OHM J
R502	76011102	CHIP 1/20W 1K OHM J
R503	76011101	CHIP 1/20W 100 OHM J
R504	76011101	CHIP 1/20W 100 OHM J

Location No.	Parts No.	Description
R505	76011101	CHIP 1/20W 100 OHM J
R620	76011103	CHIP 1/20W 10K OHM J
R621	76366103	CARBON FILM 1/6W 10K OHM J
R660	76011223	CHIP 1/20W 22K OHM J
R662	76011222	CHIP 1/20W 2.2K OHM J
R664	76011223	CHIP 1/20W 22K OHM J
R666	76011222	CHIP 1/20W 2.2K OHM J
R671	76011103	CHIP 1/20W 10K OHM J
R672	76011103	CHIP 1/20W 10K OHM J
R673	76011103	CHIP 1/20W 10K OHM J
R674	76011103	CHIP 1/20W 10K OHM J
R675	76011104	CHIP 1/20W 100K OHM J
R686	76011229	CHIP 1/16W 2.2 OHM J
R687	76011229	CHIP 1/16W 2.2 OHM J
R701	76011101	CHIP 1/20W 100 OHM J
R702	76366821	CARBON FILM 1/6W 820 OHM J (U901)
	76011102	CHIP 1/20W 1K OHM J (U902)
R704	76011470	CHIP 1/20W 47 OHM J
R705	76011221	CHIP 1/20W 220 OHM J
R709	76366563	CARBON FILM 1/6W 56K OHM J
R713	76366393	CARBON FILM 1/6W 39K OHM J
R715	76366223	CARBON FILM 1/6W 22K OHM J
R716	76366273	CARBON FILM 1/6W 27K OHM J
R717	76366333	CARBON FILM 1/6W 33K OHM J
R719	76366392	CARBON FILM 1/6W 3.9K OHM J
R720	76366392	CARBON FILM 1/6W 3.9K OHM J
R721	76366102	CARBON FILM 1/6W 1K OHM J
R722	76552471	OXIDE METAL FILM 1/2W 470 OHM J
R723	76366471	CARBON FILM 1/6W 470 OHM J
R724	76366470	CARBON FILM 1/6W 47 OHM J
R725	76366182	CARBON FILM 1/6W 1.8K OHM J
R730	76552100	OXIDE METAL FILM 1/2W 10 OHM J
R731	76552331	OXIDE METAL FILM 1/2W 330 OHM J
R732	76366820	CARBON FILM 1/6W 82 OHM J
R733	76366683	CARBON FILM 1/6W 68K OHM J
R734	76366820	CARBON FILM 1/6W 82 OHM J
R735	76366683	CARBON FILM 1/6W 68K OHM J
R736	76366620	CARBON FILM 1/6W 62 OHM J
R737	76366152	CARBON FILM 1/6W 1.5K OHM J
R738	76366102	CARBON FILM 1/6W 1K OHM J
R739	76366152	CARBON FILM 1/6W 1.5K OHM J
R740	76366620	CARBON FILM 1/6W 62 OHM J
R741	76366279	CARBON FILM 1/6W 2.7 OHM J
R742	76366279	CARBON FILM 1/6W 2.7 OHM J
R743	76554221	OXIDE METAL FILM 2W 220 OHM J
R744	76366122	CARBON FILM 1/6W 1.2K OHM J
R745	76366122	CARBON FILM 1/6W 1.2K OHM J
R760	76366101	CARBON FILM 1/6W 100 OHM J
R775	76366182	CARBON FILM 1/6W 1.8K OHM J
△ R801	76017010	METAL GLAZE 1/2W PRC92M02M20J
R805	76366221	CARBON FILM 1/6W 220 OHM J
△ R808	76079005	THERMISTOR PTC DGC3D4R5M27
R811	76366225	CARBON FILM 1/6W 2.2M OHM J
R812	76510479	CERAMIC COVERED 5W 4.7 OHM J
R813	76120004	CEMENT RES FUSIBLE SQMT-3W-1R8K
R817	76366124	CARBON FILM 1/6W 120K OHM J
R818	76366229	CARBON FILM 1/6W 2.2 OHM J
R820	76366224	CARBON FILM 1/6W 220K OHM J
R825	76366474	CARBON FILM 1/6W 470K OHM J
R826	76366564	CARBON FILM 1/6W 560K OHM J
R829	76182014	METAL R ERX1FJR22H
R830	76019459	METAL PLATE 2W 0.12 OHM J
R831	76366152	CARBON FILM 1/6W 1.5K OHM J
R832	76366183	CARBON FILM 1/6W 18K OHM J
R833	76011223	CHIP 1/20W 22K OHM J
R834	76366222	CARBON FILM 1/6W 2.2K OHM J
R837	76011102	CHIP 1/20W 1K OHM J
R838	76366392	CARBON FILM 1/6W 3.9K OHM J
R839	76366222	CARBON FILM 1/6W 2.2K OHM J
R840	76011472	CHIP 1/20W 4.7K OHM J
R841	76011152	CHIP 1/20W 1.5K OHM J
R842	76011472	CHIP 1/20W 4.7K OHM J
R843	76000445	CHIP JUMPER 1608TYPE
R846	76011154	CHIP 1/20W 150K OHM J
R847	76000445	CHIP JUMPER 1608TYPE
R848	76011101	CHIP 1/20W 100 OHM J
R898	76321228	OXIDE METAL FILM 1/2W 0.22 OHM J
△ R899	76017012	METAL GLAZE 1/2W PRC92M08M20J
R901	76376222	CARBON FILM 1/2W 2R2K J

Location No.	Parts No.	Description
R902	76376222	CARBON FILM 1/2W 2R2K J
R903	76376222	CARBON FILM 1/2W 2R2K J
R904	76376101	CARBON FILM RD50JHBA101
R905	76376101	CARBON FILM RD50JHBA101
R906	76376101	CARBON FILM RD50JHBA101
R907	76383101	OXIDE METAL FILM 2W 100 OHM J
R911	76366101	CARBON FILM 1/6W 100 OHM J
R912	76366101	CARBON FILM 1/6W 100 OHM J
R913	76366101	CARBON FILM 1/6W 100 OHM J
R920	76000568	FUSIBLE 1W 4.7 OHM J
R936	76545150	FUSIBLE 1/4W 15 OHM J
R937	76366181	CARBON FILM 1/6W 180 OHM J
R938	76366563	CARBON FILM 1/6W 56K OHM J
R939	76366102	CARBON FILM 1/6W 1K OHM J
R992	76366150	CARBON FILM 1/6W 15 OHM J
RA105	76011101	CHIP 1/20W 100 OHM J
RA106	76011101	CHIP 1/20W 100 OHM J
RA108	76011332	CHIP 1/20W 3.3K OHM J
RA109	76011332	CHIP 1/20W 3.3K OHM J
RA14	76366100	CARBON FILM 1/6W 10 OHM J
RA15	76366100	CARBON FILM 1/6W 10 OHM J
RA16	76366473	CARBON FILM 1/6W 47K OHM J
RA17	76366472	CARBON FILM 1/6W 4.7K OHM J
RA18	76366473	CARBON FILM 1/6W 47K OHM J
RA19	76366100	CARBON FILM 1/6W 10 OHM J
RA20	76366100	CARBON FILM 1/6W 10 OHM J
RA21	76366472	CARBON FILM 1/6W 4.7K OHM J
RA30	76011153	CHIP 1/20W 15K OHM J
RA31	76011101	CHIP 1/20W 100 OHM J
RA32	76366153	CARBON FILM 1/6W 15K OHM J
RA33	76011153	CHIP 1/20W 15K OHM J
RA34	76011153	CHIP 1/20W 15K OHM J
RA35	76011101	CHIP 1/20W 100 OHM J
RA36	76011101	CHIP 1/20W 100 OHM J
RA98	76011472	CHIP 1/20W 4.7K OHM J
RA99	76011472	CHIP 1/20W 4.7K OHM J
RB08	76011102	CHIP 1/20W 1K OHM J
RB09	76011332	CHIP 1/20W 3.3K OHM J
RB21	76366122	CARBON FILM 1/6W 1.2K OHM J
RB22	76366151	CARBON FILM 1/6W 150 OHM J
RB23	76366181	CARBON FILM 1/6W 180 OHM J
RB24	76366241	CARBON FILM 1/6W 240 OHM J
RB25	76366331	CARBON FILM 1/6W 330 OHM J
RB26	76366471	CARBON FILM 1/6W 470 OHM J
RB30	76366470	CARBON FILM 1/6W 47 OHM J
RB31	76366103	CARBON FILM 1/6W 10K OHM J
RB32	76366560	CARBON FILM 1/6W 56 OHM J
RB33	76366221	CARBON FILM 1/6W 220 OHM J
RB34	76366223	CARBON FILM 1/6W 22K OHM J
RB35	76366102	CARBON FILM 1/6W 1K OHM J
RB49	76366102	CARBON FILM 1/6W 1K OHM J
RC01	76000445	CHIP JUMPER 1608TYPE
RC02	76000445	CHIP JUMPER 1608TYPE
RC03	76000445	CHIP JUMPER 1608TYPE
RC04	76000445	CHIP JUMPER 1608TYPE
RC05	76000445	CHIP JUMPER 1608TYPE
RC06	76000445	CHIP JUMPER 1608TYPE
RS01	76011473	CHIP 1/20W 47K OHM J
RS02	76011473	CHIP 1/20W 47K OHM J
RS03	76011473	CHIP 1/20W 47K OHM J
RS04	76011473	CHIP 1/20W 47K OHM J
RS05	76011102	CHIP 1/20W 1K OHM J
RS06	76011102	CHIP 1/20W 1K OHM J
RS09	76011561	CHIP 1/20W 560 OHM J
RS10	76011101	CHIP 1/20W 100 OHM J
RS11	76011101	CHIP 1/20W 100 OHM J
RS12	76011222	CHIP 1/20W 2.2K OHM J
RS13	76011222	CHIP 1/20W 2.2K OHM J
RS14	76011104	CHIP 1/20W 100K OHM J
RS15	76011104	CHIP 1/20W 100K OHM J
RS16	76011103	CHIP 1/20W 10K OHM J
RS17	76011103	CHIP 1/20W 10K OHM J
RS18	76011104	CHIP 1/20W 100K OHM J
RS19	76011103	CHIP 1/20W 10K OHM J
RS20	76011103	CHIP 1/20W 10K OHM J
RS21	76011103	CHIP 1/20W 10K OHM J
RS23	76011103	CHIP 1/20W 10K OHM J
RS24	76011103	CHIP 1/20W 10K OHM J
RS25	76011103	CHIP 1/20W 10K OHM J

Location No.	Parts No.	Description
RS26	76011103	CHIP 1/20W 10K OHM J
RS27	76011103	CHIP 1/20W 10K OHM J
RS28	76011103	CHIP 1/20W 10K OHM J
RS29	76011103	CHIP 1/20W 10K OHM J
RS30	76011103	CHIP 1/20W 10K OHM J
RS31	76011103	CHIP 1/20W 10K OHM J
RS32	76011103	CHIP 1/20W 10K OHM J
RS33	76011101	CHIP 1/20W 100 OHM J
RS34	76011101	CHIP 1/20W 100 OHM J
RS35	76011101	CHIP 1/20W 100 OHM J
RS36	76011101	CHIP 1/20W 100 OHM J
RS40	76366473	CARBON FILM 1/6W 47K OHM J
RS41	76366473	CARBON FILM 1/6W 47K OHM J
RS63	76552271	OXIDE METAL FILM 1/2W 270 OHM J
RS64	76552271	OXIDE METAL FILM 1/2W 270 OHM J
RV01	76011750	CHIP 1/20W 75 OHM J
RV02	76011101	CHIP 1/20W 100 OHM J
RV03	76011750	CHIP 1/20W 75 OHM J
RV04	76000445	CHIP JUMPER 1608TYPE
RV05	76011750	CHIP 1/20W 75 OHM J
RV06	76000445	CHIP JUMPER 1608TYPE
RV07	76011750	CHIP 1/20W 75 OHM J
RV08	76000445	CHIP JUMPER 1608TYPE
RV09	76011750	CHIP 1/20W 75 OHM J
RV10	76000445	CHIP JUMPER 1608TYPE
RV11	76011750	CHIP 1/20W 75 OHM J
RV15	76366101	CARBON FILM 1/6W 100 OHM J
RV16	76011101	CHIP 1/20W 100 OHM J
RV19	76011101	CHIP 1/20W 100 OHM J
RV21	76011102	CHIP 1/20W 1K OHM J
RV22	76011102	CHIP 1/20W 1K OHM J
RV25	76366101	CARBON FILM 1/6W 100 OHM J
RV26	76366750	CARBON FILM 1/6W 75 OHM J
COILS & TRANSFORMERS		
G404	23103308	FERRITE CORE TEM2011AO 3.5X4.5
G405	23103308	FERRITE CORE TEM2011AO 3.5X4.5
G461	23103308	FERRITE CORE TEM2011AO 3.5X4.5
GL601	23103308	FERRITE CORE TEM2011AO 3.5X4.5
GL889	23103311	FERRITR CHOKE TEM2014AO 3.5X5X2
L101	23289187	COIL PEAKING 0.22MMHK COLTRF4R22AV
L102	23289043	COIL PEAKING TRF4100AU
L103	23289197	COIL PEAKING 1.2MMHK CNSS (NP)-1R2J
L104	23248461	COIL CHOKE TLN3278AC
L110	#2 23289043	COIL PEAKING TRF4100AU
L156	23289196	COIL PEAKING 1.0MMHK COLTRF41R0AV
L157	23289196	COIL PEAKING 1.0MMHK COLTRF41R0AV
L301	23103308	FERRITE CORE TEM2011AO 3.5X4.5
L441	23233132	COIL LINEARITY TLN2083AH
L442	23248404	COIL CHOKE TLN3383D
L461	23248375	COIL CHOKE 19X29H 470MMHK 1.5A TLN3335AA
L462	23231491	DEFLECTION YOKE 29" PF DY TDY-829HP
L462A	23993696	BOARD CORRECTION
L462B	23949616	CONVER COMPENSATOR TC-R (YV)
L462C	23993081	METAL SHEET CONV. CORRECTION TCRMX01H
L462D	23948535	SHEET MAGNETIC FERRITE
L462E	23948536	SHEET MAGNETIC FERRITE
L501	23289043	COIL PEAKING TRF4100AU
L502	23289043	COIL PEAKING TRF4100AU
L503	23289043	COIL PEAKING TRF4100AU
L504	23289043	COIL PEAKING TRF4100AU
L702	23103323	FERRITE CORE HC5-035
L704	23103308	FERRITE CORE TEM2011AO 3.5X4.5
L705	23103308	FERRITE CORE TEM2011AO 3.5X4.5
L805	23248423	COIL CHOKE TLN3481AC
L806	23248423	COIL CHOKE TLN3481AC
L811	23103308	FERRITE CORE TEM2011AO 3.5X4.5
L815	23103308	FERRITE CORE TEM2011AO 3.5X4.5
L882	23103308	FERRITE CORE TEM2011AO 3.5X4.5
L883	23221142	COIL CHOKE TRF9253D
L885	23248400	COIL CHOKE TLN3299D
L886	23103308	FERRITE CORE TEM2011AO 3.5X4.5
L888	23289174	COIL PEAKING 10MMHK TWE5NP-100K-5
L889	23289174	COIL PEAKING 10MMHK TWE5NP-100K-5
L891	23103308	FERRITE CORE TEM2011AO 3.5X4.5
L892	23103308	FERRITE CORE TEM2011AO 3.5X4.5
L894	23103308	FERRITE CORE TEM2011AO 3.5X4.5
△ L901	23204003	COIL DG 0.5ALU 48T 8TYPE TSB-2389EAL
LA01	23289049	COIL PEAKING TRF4330AU

Location No.	Parts No.	Description
LA03	23289043	COIL PEAKING TRF4100AU
LA04	23289043	COIL PEAKING TRF4100AU
LA05	23289043	COIL PEAKING TRF4100AU
LA101	23289043	COIL PEAKING TRF4100AU
LA110	23289043	COIL PEAKING TRF4100AU
LA117	23289043	COIL PEAKING TRF4100AU
LA124	23289043	COIL PEAKING TRF4100AU
LA14	23289043	COIL PEAKING TRF4100AU
LA88	23289043	COIL PEAKING TRF4100AU
LA90	23289043	COIL PEAKING TRF4100AU
LA93	23289043	COIL PEAKING TRF4100AU
LA94	23289043	COIL PEAKING TRF4100AU
LA96	23289043	COIL PEAKING TRF4100AU
T401	23224395	TRANSFORMER HORIZ DRIVER TLN1098AH
△ T461	23236962	TRANSFORMER FBT TFB4228AT
△ T801	23211793	COIL LINE FILTER TRF3247AW
△ T802	23211838	COIL LINE FILTER TRF3202AR
△ T862	23217777	TRANSFORMER TPW3573AM
V901M	23102565	COIL CMG29.1VM6TLEAD3P MAG-1124
Z101	#1 23303363	FILTER SAW BSF6284K
	#2 23303176	SAW FILTER 38MHZ PIF SIF INTER OFWK2964M
	#3 23303363	SAW FILTER BSF6284K
Z102	#1 23303356	FILTER SAW BSF9351K
	#3 23303356	SAW FILTER BSF9351K BSF9351K
Z104	#2 23303353	FILTER FIL CFILT 5.74MHZ EFCS5R74YS5A
SEMICONDUCTORS		
D101	23362104	DIODE ZENER DZ33 BS C
D103	#1 23362138	DIODE KDS114-RTK
	#3 23362138	DIODE KDS114-RTK
D202	23357697	DIODE 1SS133
D203	23357697	DIODE 1SS133
D301	23362228	DIODE VRM=200V 1N4003F
D302	23357372	DIODE EU2JGF-41U2
D303	23357917	DIODE SC570A
D311	23362140	DIODE KDS160-RTK
D312	23362069	DIODE ZENER DZ5.6 BS A
D313	23357372	DIODE EU2JGF-41U2
D406	23357372	DIODE EU2JGF-41U2
D408	23357471	DIODE RU4DG-3AM2
D441	23362071	DIODE ZENER DZ5.6 BS C
D444	23357705	DIODE ERC06-15
D445	23362081	DIODE ZENER DZ9.1 BS C
D461	23357364	DIODE RU4JGF- M2
D467	23357372	DIODE EU2JGF-41U2
D470	23362107	DIODE ZENER DZ36 BS B
D4703	23362140	DIODE KDS160-RTK
D475	23357697	DIODE 1SS133
D476	23357697	DIODE 1SS133
D501	23362140	DIODE KDS160-RTK
D502	23362140	DIODE KDS160-RTK
D670	23362140	DIODE KDS160-RTK
D671	23362140	DIODE KDS160-RTK
D672	23362140	DIODE KDS160-RTK
D673	23362140	DIODE KDS160-RTK
D674	23362140	DIODE KDS160-RTK
D680	23362140	DIODE KDS160-RTK
D681	23362140	DIODE KDS160-RTK
D682	23362140	DIODE KDS160-RTK
D683	23362140	DIODE KDS160-RTK
D704	23357697	DIODE 1SS133
D705	23357697	DIODE 1SS133
D715	23357697	DIODE 1SS133
D720	23357697	DIODE 1SS133
D721	23357697	DIODE 1SS133
D801	23362217	DIODE BRG. VRM600V IO6A GBU6J-T1
D805	23362235	DIODE VRM=200V IO=1.0A FTRR 1EDG-41A
D807	23357372	DIODE EU2JGF-41U2
D808	23357372	DIODE EU2JGF-41U2
D809	23362094	DIODE ZENER DZ15 BS B
D812	23362070	DIODE ZENER DZ5.6 BS B
D813	23362070	DIODE ZENER DZ5.6 BS B
D814	23362094	DIODE ZENER DZ15 BS B
D815	23362103	DIODE ZENER DZ33 BS B
D816	23362235	DIODE VRM=200V IO=1.0A FTRR 1EDG-41A
D817	23362235	DIODE VRM=200V IO=1.0A FTRR 1EDG-41A
D818	23357372	DIODE EU2JGF-41U2
D841	23362067	DIODE ZENER DZ5.1 BS B
D845	23357697	DIODE 1SS133

Location No.	Parts No.	Description
D883	23357364	DIODE RU4JGF- M2
D885	23357471	DIODE RU4DG-3AM2
D891	23362235	DIODE VRM=200V IO=1.0A FTRR 1EDG-41A
D892	23357372	DIODE EU2JGF-41U2
D893	23362235	DIODE VRM=200V IO=1.0A FTRR 1EDG-41A
D894	23357492	DIODE VRM=200IO=2A UG2D-41A-U4
D901	23357104	DIODE 1SS244
D902	23357104	DIODE 1SS244
D903	23357104	DIODE 1SS244
D904	23357104	DIODE 1SS244
D905	23357104	DIODE 1SS244
D906	23357104	DIODE 1SS244
D907	76019471	VARISTOR TNR10V271K
D911	23357372	DIODE EU2JGF-41U2
D913	23357697	DIODE 1SS133
D914	23357697	DIODE 1SS133
D915	23357697	DIODE 1SS133
D916	23357697	DIODE 1SS133
D918	23362151	DIODE ZV=3.92-4.14 DZ3.9 BS B
D919	23362151	DIODE ZV=3.92-4.14 DZ3.9 BS B
D920	23362151	DIODE ZV=3.92-4.14 DZ3.9 BS B
DA110	23362069	DIODE ZENER DZ5.6 BS A
DA111	23362069	DIODE ZENER DZ5.6 BS A
DA118	23362144	DIODE ZV=1.88-2.10 DZ2.0 BS A
DA119	23357406	DIODE ZENER UDZS5.6B
DA120	23357697	DIODE 1SS133
DA121	23362140	DIODE KDS160-RTK
DB21	23358577	DIODE LED RED/GREEN BT-H684W
KB21	23085842	IC REMOCON RECEIVER ROM-N338TB
Q101	23205509	TRANSISTOR 2SC4988FRTL-E
Q102	#2 23205277	TRANSISTOR 2SC4116-Y (TE85LF)
Q107	#1 23205214	TRANSISTOR NPN R1=R2=10KOHM SRC1202U (SOT-323)
	#3 23205214	TRANSISTOR NPN R1=R2=10KOHM SRC1202U (SOT-323)
Q108	#1 23205214	TRANSISTOR NPN R1=R2=10KOHM SRC1202U (SOT-323)
	#3 23205214	TRANSISTOR NPN R1=R2=10KOHM SRC1202U (SOT-323)
Q301	23085439	IC AN5523
Q320	23205358	TRANSISTOR KTC3875S Y/P
Q401	23205277	TRANSISTOR 2SC4116-Y (TE85LF)
Q402	23205479	TRANSISTOR FET 2SK941 (F)
Q404	23205502	TRANSISTOR 2SD2539(FAF)
Q460	23205535	TRANSISTOR NMOS FET VDSS=200V STK630F
Q471	23205433	TRANSISTOR KTA1024-Y/P
Q472	23205277	TRANSISTOR 2SC4116-Y (TE85LF)
Q473	23205357	TRANSISTOR KTA1504S Y/P
Q610	23085693	IC AN5277
Q670	23205276	TRANSISTOR 2SA1586Y (TE85LF)
Q671	23205424	TRANSISTOR KTC2875B/P
Q672	23205424	TRANSISTOR KTC2875B/P
Q701	23205358	TRANSISTOR KTC3875S Y/P
Q706	23205376	TRANSISTOR 2SC5343-Y (BULK)
Q707	23205314	TRANSISTOR 2SC752 (G) TM-Y (F)
Q709	23205376	TRANSISTOR 2SC5343-Y (BULK)
Q710	23205372	TRANSISTOR 2SA1980-Y (BULK)
Q711	23205435	TRANSISTOR KTA1837P
Q712	23205434	TRANSISTOR KTC4793P
Q719	23205376	TRANSISTOR 2SC5343-Y (BULK)
Q720	23205376	TRANSISTOR 2SC5343-Y (BULK)
Q773	23205376	TRANSISTOR 2SC5343-Y (BULK)
Q801	23135069	IC STRF6268S
Q802	23205543	TRANSISTOR FN155
Q803	23205376	TRANSISTOR 2SC5343-Y (BULK)
Q805	23205229	TRANSISTOR SRC1205M
△ Q826	23085841	PHOTO COUPLER VCEO=80V IF=50M K1010HB CTR
Q831	23085812	IC KIA78D05F-RTF/P
Q835	23085730	IC AN34040A
Q841	23205277	TRANSISTOR 2SC4116-Y (TE85LF)
Q842	23205277	TRANSISTOR 2SC4116-Y (TE85LF)
Q844	23085792	IC KIA 78D33 PI
Q883	23009991	IC SE133N LF4
Q901	23085754	IC TDA6107AJF
Q908	23205202	TRANSISTOR 2SC5344Y
Q909	23205376	TRANSISTOR 2SC5343-Y (BULK)
QA10	#1 23085765	IC AT24C16A-10PU2.7
	#2 23085764	IC AT24C08A-10PU2.7
	#3 23085764	IC AT24C08A-10PU2.7
QA14	23205358	TRANSISTOR KTC3875S Y/P
QA15	23205586	TRANSISTOR PNP 2SA1013-R(F)
QA16	23205358	TRANSISTOR KTC3875S Y/P
QA17	23205586	TRANSISTOR PNP 2SA1013-R(F)

Location No.	Parts No.	Description
QA51	#1 23085647	IC TDA12021H/N1F01
	#2 23085798	IC PHILIPS UOC3-AVST (NO-TXT) TDA12063H/N1F00
	#3 23085796	IC TDA12011H/N1F00
QB04	23205358	TRANSISTOR KTC3875S Y/P
QB21	23205376	TRANSISTOR 2SC5343-Y (BULK)
QB22	23205372	TRANSISTOR 2SA1980-Y (BULK)
QS01	23205277	TRANSISTOR 2SC4116-Y (TE85LF)
QS02	23205277	TRANSISTOR 2SC4116-Y (TE85LF)
QS03	23205424	TRANSISTOR KTC2875B/P
QS04	23205424	TRANSISTOR KTC2875B/P
QS05	23205222	TRANSISTOR PNP R1=R2=47KOHM SRA2204S (SOT-23)
QV02	23205357	TRANSISTOR KTA1504S Y/P
MISCELLANEOUS		
C903A	23965241	TAPE CC #12 10MM L30M
△ F470	23144297	FUSE CARTRIDGE 250V 1A 5.2X20
F470A	23165469	FUSE HOLDER 5.2 DFH-001
F470B	23165469	FUSE HOLDER 5.2 DFH-001
△ F801	23144302	FUSE CARTRIDGE 250V 4A 5.2X20
F801A	23165469	FUSE HOLDER 5.2 DFH-001
F801B	23165469	FUSE HOLDER 5.2 DFH-001
△ F802	23144200	FUSE CARTRIDGE 5.2X20 250V 3A
F802A	23165469	FUSE HOLDER 5.2 DFH-001
F802B	23165469	FUSE HOLDER 5.2 DFH-001
J602D	23171400	WIRE PVC SOLDER-PLATED 300V 7/16 BRN UL CSA
J602E	23171400	WIRE PVC SOLDER-PLATED 300V 7/16 BRN UL CSA
M461A	23192251	CABLE ANODE CAP ASSY TCC5606CT
M461B	23507638	CABLE FOCUS
M461C	23507543	CABLE ASSY CABLE SCREEN
N724	23965900	TAPE GLASS-CLOTH W/ADHESIVE W=18 T=0.18
N728	23960101	SILICONE RUBBER TSE-382 RTV
P107	23713756	PLUG 5P 2.5MM G B5B-EH-F1-TV4
P401	23757267	CONNECTOR B06B-DVS-L JST B06B-DVS-L (LF)
P501	23713756	PLUG 5P 2.5MM G B5B-EH-F1-TV4
P601A	23713755	PLUG 4P 2.5MM G B4B-EH-F1-TV4
P601B	23713755	PLUG 4P 2.5MM G B4B-EH-F1-TV4
P602	23713755	PLUG 4P 2.5MM G B4B-EH-F1-TV4
P662	23023116	PLUG HEAD PHONE JACK 3.5MM PJ3-14-7
P704A	23713755	PLUG 4P 2.5MM G B4B-EH-F1-TV4
P704B	23713755	PLUG 4P 2.5MM G B4B-EH-F1-TV4
△ P801	#1 23372323	POWER CORD AC CORD CEE M4206-2.5M
	#2 23372333	POWER CORD THAI KP-10KW -2.5M
	#3 23372323	POWER CORD AC CORD CEE M4206-2.5M
P902A	23713759	PLUG 8P 2.5MM G B8B-EH-F1-TV4
P902B	23713759	PLUG 8P 2.5MM G B8B-EH-F1-TV4
P903A	23713757	PLUG 6P 2.5MM G B6B-EH-F1-TV4
P903B	23713757	PLUG 6P 2.5MM G B6B-EH-F1-TV4
P910	23164725	PLUG 2P
PA21A	23713757	PLUG 6P 2.5MM G B6B-EH-F1-TV4
PA21B	23713757	PLUG 6P 2.5MM G B6B-EH-F1-TV4
PB01	23713755	PLUG 4P 2.5MM G B4B-EH-F1-TV4
PV01	23023429	JACK 11P+1SV JACK (4SW)-852V2-01 NI FE LF
PV03	23023258	JACK 3P MTJ-032-39BBA-432
Q301B	23717241	SCREW BITTB3X8 ECO
Q301G	23960136	ADHESIVE SILICONE TSE3843-W
Q404B	23738136	SCREW 3X10MM
Q404G	23960136	ADHESIVE SILICONE TSE3843-W
Q460B	23717241	SCREW BITTB3X8 ECO
Q610B	23717241	SCREW BITTB3X8 ECO
Q801B	23738136	SCREW 3X10MM
Q801G	23960136	ADHESIVE SILICONE TSE3843-W
Q835B	23717241	SCREW BITTB3X8 ECO
Q844B	23717241	SCREW BITTB3X8 ECO
△ S801	23344545	SWITCH POWER KDC-A20-1-8A
SA11	23344516	SWITCH TACTING TSV TYP TSVB-1
SA12	23344516	SWITCH TACTING TSV TYP TSVB-1
SA13	23344516	SWITCH TACTING TSV TYP TSVB-1
SA14	23344516	SWITCH TACTING TSV TYP TSVB-1
SA15	23344516	SWITCH TACTING TSV TYP TSVB-1
SA16	23344516	SWITCH TACTING TSV TYP TSVB-1
△ SR81	23146587	RELAY DC12V 0.53W G5PA-1-M
△ SR83	23146585	RELAY DC12V 2M G5PA-2 DC12
△ V901A	23903174	SOCKET CRT ISH46S-EN ING
V901B	23102456	MAGNET MARG4006
W661	23351339	SPEAKER SPK 8-OHM 10W SPK-1410AL
W662	23351339	SPEAKER SPK 8-OHM 10W SPK-1410AL
XA03	23153618	CRYSTAL RESONATOR 24.576 CRYSTAL 24.5MHZ
Z891	23144415	FUSE PROTECTOR 125V 4A SMP125M04A00
Z892	23144415	FUSE PROTECTOR 125V 4A SMP125M04A00

Location No.	Parts No.	Description
Z894	23144415	FUSE PROTECTOR 125V 4A SMP125M04A00
PC BOARD ASSEMBLIES		
* U901	23764818	PC BOARD ASSY PD2078A CRT/D
* U902	#1 23764737	PC BOARD ASSY PD2249C SIGNAL
*	#2 23764846	PC BOARD ASSY PD2249R SIGNAL
*	#3 23764768	PC BOARD ASSY PD2249H SIGNAL
* U903	23764738	PC BOARD ASSY PD2276 FRONT
PICTURE TUBE		
△ V901	23324229	PICTURE TUBE 29 PF ORION A68QFD290X
TUNER		
H001	23321549	TUNER ASIA HYPER FS5V B8A86ST
ACCESSORIES		
A701	23015306	CARTON BOX
K902	#1 23306623	REMOCON HAND UNIT IR CT-90229
	#2 23306624	REMOCON HAND UNIT IR CT-90230
	#3 23306624	REMOCON HAND UNIT IR CT-90230
Y101A	#1 23566823	OWNERS MANUAL ENGLISH
	#2 23566855	OWNERS MANUAL ENGLISH/THAI
	#3 23566836	OWNERS MANUAL ENGLISH
Y101B	#1 23566824	OWNERS MANUAL INDONESIAN
	#3 23566837	OWNERS MANUAL INDONESIAN
Y120	23943846	BAG POLY
Y121	#1 23943846	BAG POLY
	#3 23943846	BAG POLY
CABINET PARTS		
A201	#1 23533666	COVER FRONT ASSY
	#2 23533666	COVER FRONT ASSY
	#3 23571086	COVER FRONT ASSY
A401	23532083	COVER BACK COVER PROPER
A423	23929522	WASHER T=1.0
A504	23738086	SCREW BTB4X16 ECO
A508	23738086	SCREW BTB4X16 ECO
A522	23738086	SCREW BTB4X16 ECO
A702A	23946119	PACKING TOP
A702B	23946120	PACKING BOTTOM
A902	23428371	DOOR FRONT
A905	23445914	BUTTON POWER
A911	23436893	HANDLE
A914	23738088	SCREW BTBW3X12 ECO
A915	23738085	SCREW BTB4X12 ECO
B202	23738088	SCREW BTBW3X12 ECO
B212	23738086	SCREW BTB4X16 ECO
B232	23738088	SCREW BTBW3X12ECO
E912	23848729	WEDGE YOKE HOLDING 3 REQUIRED

CRT-D BOARD PD2078
BOTTOM (FOIL) SIDE

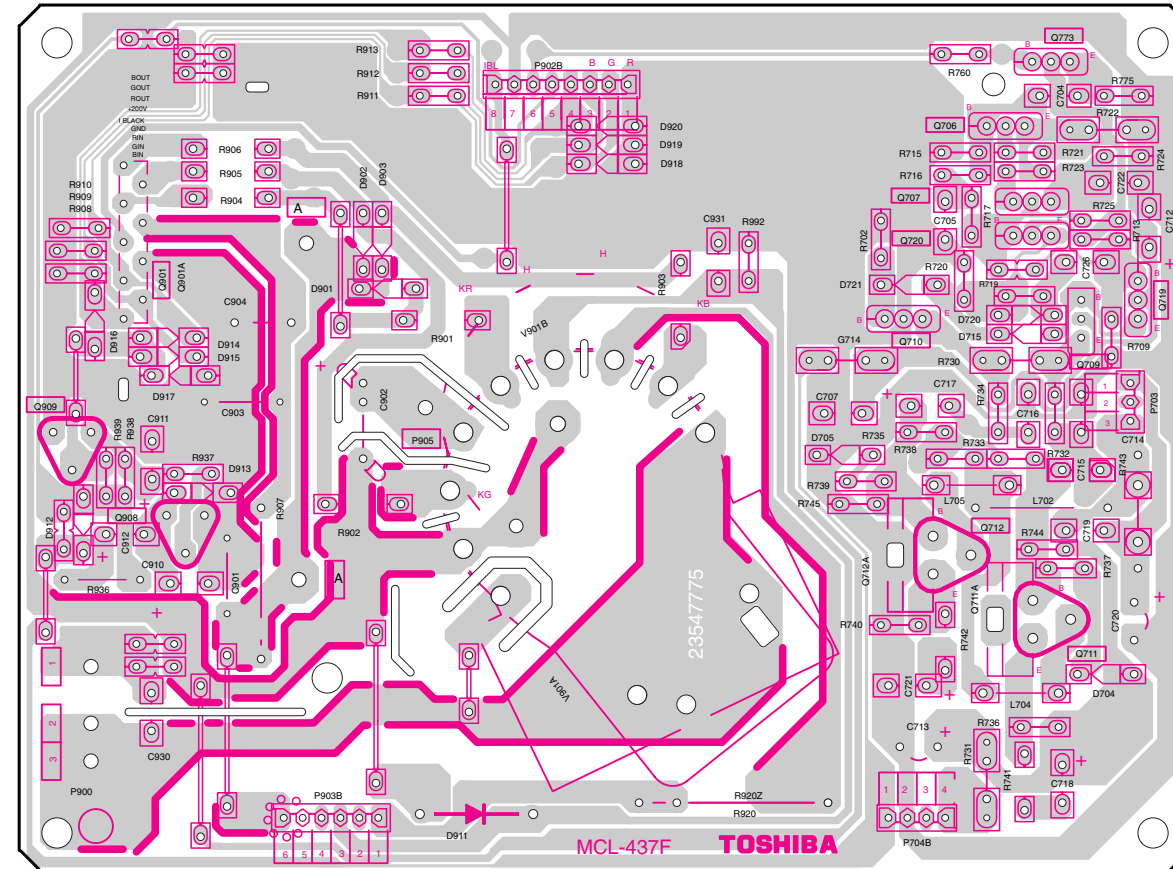

FRONT BOARD PD2276
BOTTOM (FOIL) SIDE

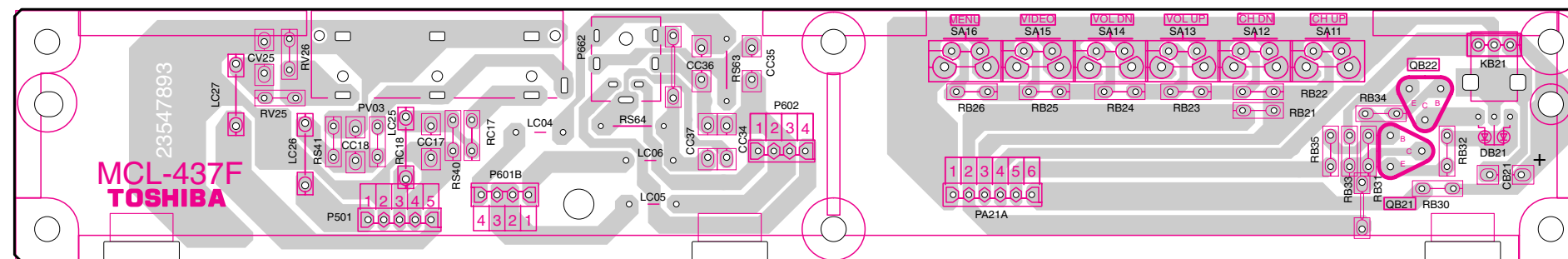

TERMINAL VIEW OF TRANSISTORS

- ① 2SD2253
(old)
2SC5243
2SC5859

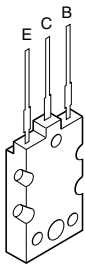

- ② 2SA1186A
2SA1306
2SA1788
2SA1837
2SA1930
2SC1569
2SC3852
2SC4544
2SC4793
2SC5171
2SD1763A
2SD2396

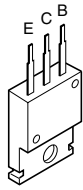

- ③ 2SA1020
2SC2482
2SC2655
2SC4721P
2SC5343
2SC5344
2SC752GTM



- ④ 2SA1015
2SA1320(F)
2SA2980
2SA562TM
2SA9335
2SC1740S
2SC1815
2SC2120
2SC2878
2SC752
KTA1266
KTC3198

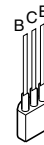

- ⑥ 2SA1788

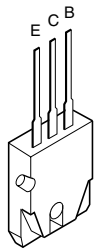

- ⑥ KRC105M
RN1201
RN1202
RN1203
RN1204
RN1205
RN2201
RN2203
RN2204

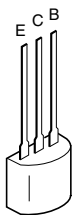

- ⑦ 2SD1554
2SD1556
2SD2253
2SD2396
2SD2553
2SD5143

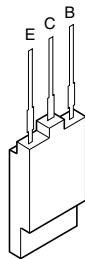

- ⑧ ON4409

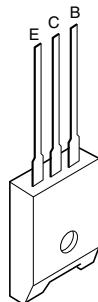

SCHEMATIC DIAGRAM

MODEL : 29CZ5DE/29CZ5T/29CZ6SI

WARNING: BEFORE SERVICING THIS CHASSIS, READ THE "X-RAY radiation precaution", "SAFETY PRECAUTION" and "PRODUCT SAFETY NOTICE" ON THE MANUAL FOR THIS MODEL.



CAUTION: The international hazard symbols " \triangle " in the schematic diagram and the parts list designate components which have special characteristics important for safety and should be replaced only with types identical to those in the original circuit or specified in the parts list. The mounting position of replacements is to be identical with originals. Before replacing any of these components, read carefully the PRODUCT SAFETY NOTICE on the MANUAL for this model. Do not degrade the safety of the receiver through improper servicing.

NOTE:

- RESISTOR** Resistance is shown in ohm [K = 1.000, M = 1.000.000]. All resistors are 1/6W and 5% tolerance carbon resistor, unless otherwise noted as the following marks.

1/2R = Metal or Metal oxide of 1/2 watt	1/2S = Carbon compstion of 1/2 watt
1RF = Fuse resistor of 1 watt	10W = Cement of 10 watt
K = $\pm 10\%$ G = $\pm 2\%$ F = $\pm 1\%$	
- CAPACITOR** Unless otherwise noted in schematic, all capacitor values less than 1 are expressed in μF , and the values more than 1 in pF.

All capacitors are ceramic 50V, unless otherwise noted as the following marks.

 Electrolytic capacitor	 Mylar capacitor
--	---
- The parts indicated with " \triangle " have special characteristics, and should be replaced with identical parts only.
- Voltages read with DIGITAL MULTI-METER from point indicated to chassing ground, using a color bar signal with all controls at normal, line voltage at 220 volts.
- Waveforms are taken receiving color bar signal with enough sensitivity.
- Voltage reading shown are nominal values and may vary $\pm 20\%$ except H.V.

■ **SCHEMATIC DIAGRAM STRUCTURE:**

MAIN Circuit	SIGNAL/MICON	[SHEET-1/6]	1/8
	VERT	[SHEET-2/6]	2/8
	HORIZONTAL	[SHEET-3/6]	3/8
	PROTECTER	[SHEET-4/6]	4/8
	LOW B REG	[SHEET-5/6]	5/8
	POWER	[SHEET-6/6]	6/8
CRT DRIVE Circuit			7/8
FRONT Circuit			8/8

CIRCUIT BLOCK DIAGRAM

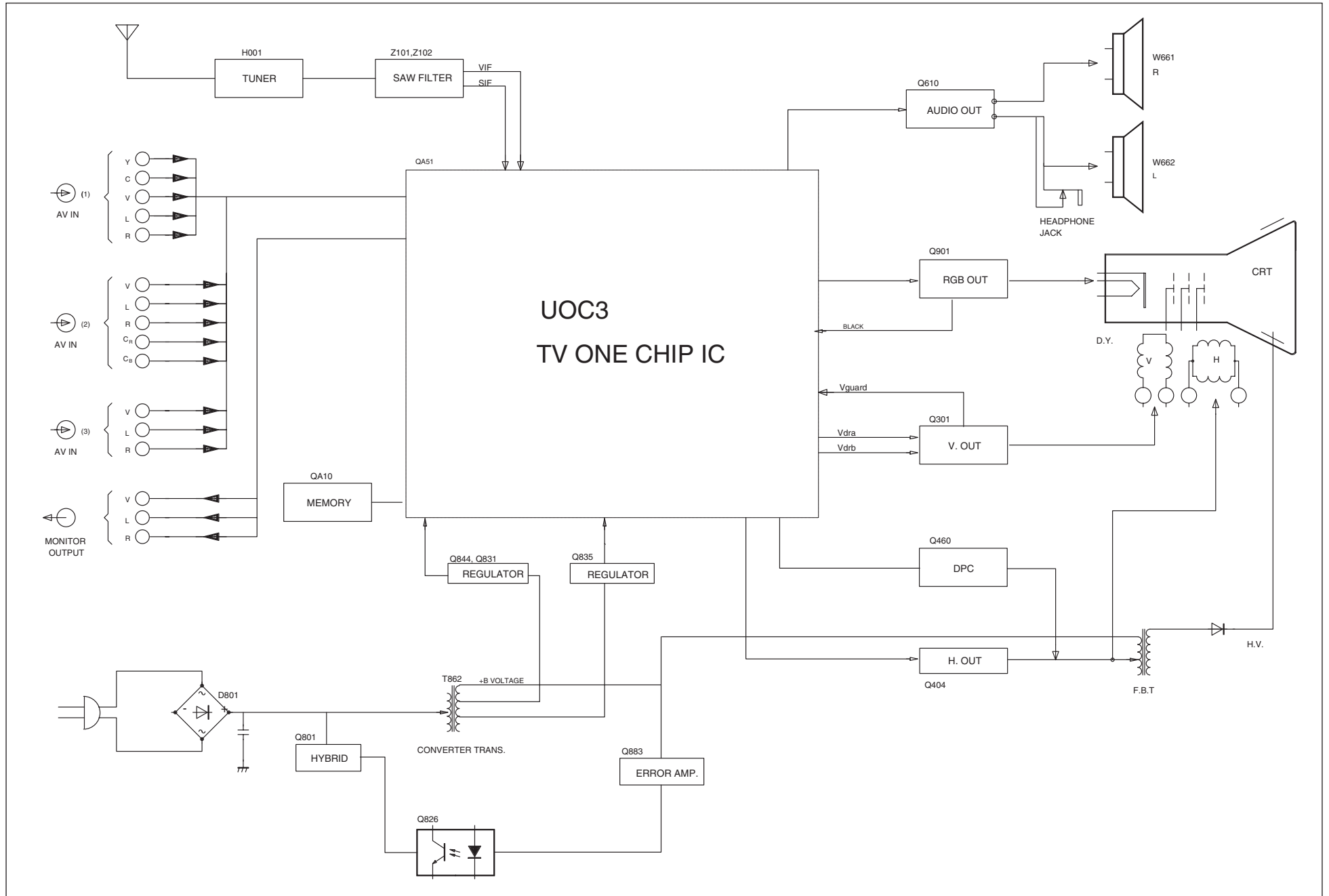

SPECIFICATIONS

MODEL		29CZ5DE/29CZ5T/29CZ6SI					
Rated voltage		~ 110 V – 240 V, 50/60 Hz					
Power consumption (at ~ 220 V, 50 Hz)		123 W					
Dimensions (Width × Depth × Height)		782.1 (W) × 492.5 (D) × 585.1 (H) mm					
Mass		44 kg					
Picture tube		Type 29 Flat square picture tube (727.4 mm) Overall picture tube measured diagonally (676.0 mm) Viewable picture tube measured diagonally 104° deflection					
Television system (Aerial input)	Channel coverage	System	Channel	VHF	UHF	CATV (Channels)	
		PAL	B/G CCIR	2 – 12	21 – 69	X ~ Z+2, S1 ~ S41	
		PAL	I UK	—	21 – 69	—	
		PAL	D/K CHINA	1 – 12	13 – 57	Z-1 ~ Z-38	
		SECAM	B/G CCIR	2 – 12	21 – 69	X ~ Z+2, S1 ~ S41	
		SECAM	D/K OIRT	1 – 12	21 – 69	X1 ~ X19	
	NTSC	M US	2 – 13	14 – 69	A-6 ~ A-1, A ~ W, AA ~ ZZ, AAA, BBB		
NTSC	M JAPAN	1 – 12	13 – 62	M1 ~ M10, S1 ~ S41			
	Special RF signal	Color system		Sound system			
		NTSC4.43		5.5/6.0/6.5 MHz			
		PAL 60Hz		5.5/6.0/6.5 MHz			
Color system (Video input)		PAL50 / PAL60 / SECAM / NTSC4.43 / NTSC3.58					
Sound output		10 W + 10 W (10 % THD)					
Speaker		6 × 12 cm (2)					
Terminals		Input [-(1)] : S-Video/Video, Audio L/MONO, Audio R Input [-(2)/DVD] : Video/Y, Pb/Cb, Pr/Cr, Audio L/MONO, Audio R Input [-(3)] : Video, Audio L/MONO, Audio R Output [G→ (MONITOR)] : Video, Audio L/MONO, Audio R Headphone output : ø 3.5mm (mini jack stereo type)					

* The shaded areas are not available for 29CZ5T.
Please refer to owner's manual in details.

TOSHIBA SINGAPORE PTE LTD



SCHEMATIC DIAGRAM

MODEL : 29CZ5DE/29CZ5T/29CZ6SI

WARNING: BEFORE SERVICING THIS CHASSIS, READ THE "X-RAY radiation precaution", "SAFETY PRECAUTION" and "PRODUCT SAFETY NOTICE" ON THE MANUAL FOR THIS MODEL.

CAUTION: The international hazard symbols " \triangle " in the schematic diagram and the parts list designate components which have special characteristics important for safety and should be replaced only with types identical to those in the original circuit or specified in the parts list. The mounting position of replacements is to be identical with originals. Before replacing any of these components, read carefully the PRODUCT SAFETY NOTICE on the MANUAL for this model. Do not degrade the safety of the receiver through improper servicing.

NOTE:

1. RESISTOR Resistance is shown in ohm [K = 1.000, M = 1.000.000]. All resistors are 1/6W and 5% tolerance carbon resistor, unless otherwise noted as the following marks.
 1/2R = Metal or Metal oxide of 1/2 watt 1/2S = Carbon compstion of 1/2 watt
 1RF = Fuse resistor of 1 watt 10W = Cement of 10 watt
 K = $\pm 10\%$ G = $\pm 2\%$ F = $\pm 1\%$
2. CAPACITOR Unless otherwise noted in schematic, all capacitor values less than 1 are expressed in μF , and the values more than 1 in pF.
 All capacitors are ceramic 50V, unless otherwise noted as the following marks.
 Electrolytic capacitor  Mylar capacitor
3. The parts indicated with " \triangle " have special characteristics, and should be replaced with identical parts only.
4. Voltages read with DIGITAL MULTI-METER from point indicated to chassing ground, using a color bar signal with all controls at normal, line voltage at 220 volts.
5. Waveforms are taken receiving color bar signal with enough sensitivity.
6. Voltage reading shown are nominal values and may vary $\pm 20\%$ except H.V.

■ SCHEMATIC DIAGRAM STRUCTURE:

MAIN Circuit	SIGNAL/MICON	[SHEET-1/6]	1/8
	VERT	[SHEET-2/6]	2/8
	HORIZONTAL	[SHEET-3/6]	3/8
	PROTECTER	[SHEET-4/6]	4/8
	LOW B REG	[SHEET-5/6]	5/8
	POWER	[SHEET-6/6]	6/8
CRT DRIVE Circuit			7/8
FRONT Circuit			8/8

CIRCUIT BLOCK DIAGRAM

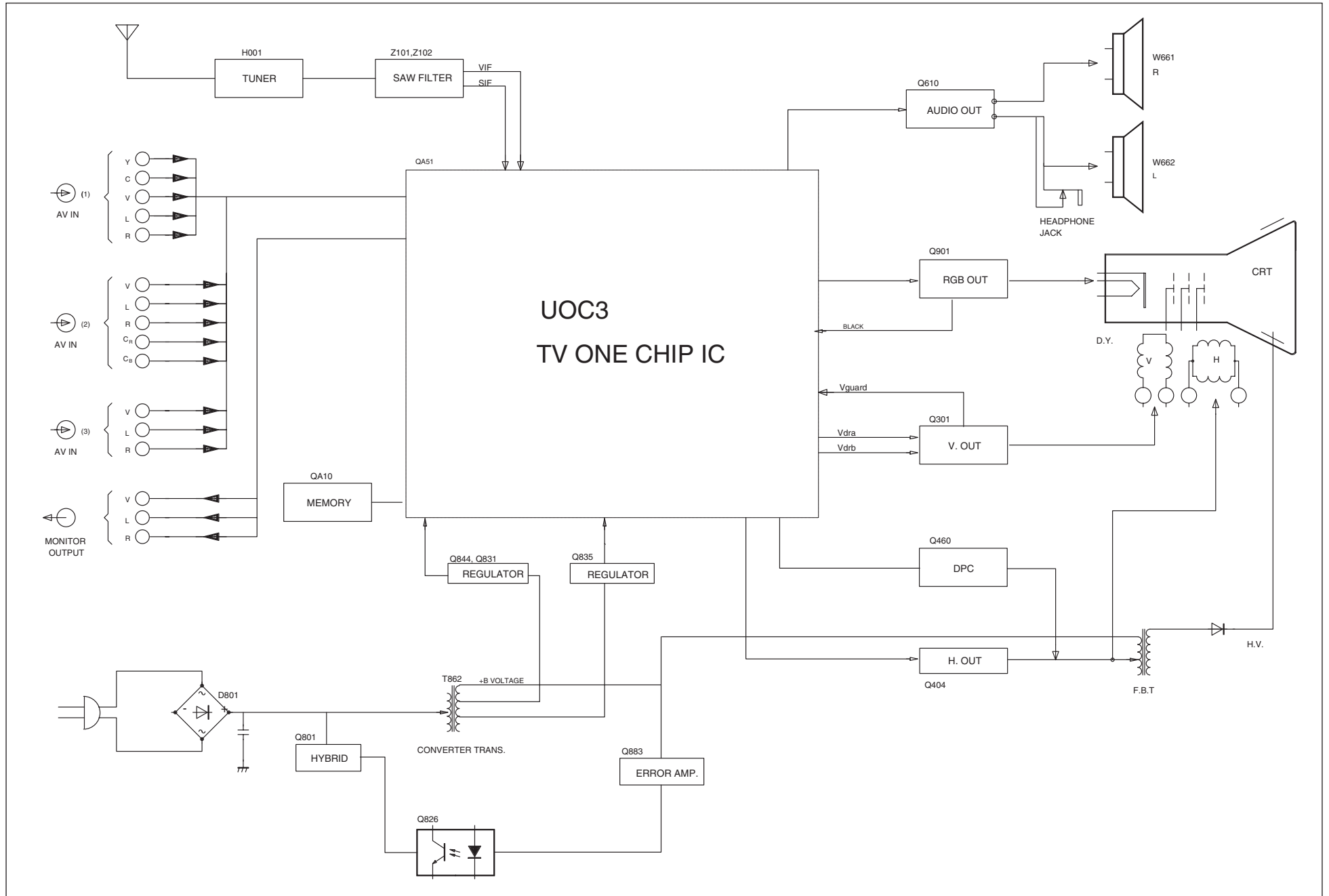

A

B

C

D

E

F

LOCATION	RUSSIA MODEL		OTHER MODEL		VIETNAM MODEL	
H001	23321514	ENV59DA7G3	(R1) 23321549 (R2) 23321545 (R3) 23321534	1158BA86ST ENV59K11G3F TAEM-G107D	23321514	ENV59DA7G3
LC04 LC05	(RA) 23103279 (RB) 23103248	TEM2014AO TEM2014AA	(R1) SHORT (R2) 100R (R3) 100R		100R	
G103	(RA) 23103249 (RB) 23103894	TEM2011AO TEM2011AA	SHORT		SHORT	

[21CZ6-8 MODELS]

LOCATION	RUSSIA MODEL	OTHER MODEL
RC01 - RC08	1k	SHORT
CC32 - CC33	10uF	KETSU
LC01 - LC03	(RA) 23221141 (RB) 23221139	TRF9240AC TRF9240AH

[29CZ5 MODELS]

LOCATION	RUSSIA MODEL	OTHER MODEL
RC01 - RC06 (MAIN) RC17 - RC18 (FRONT)	1k	SHORT
CC36 - CC37	10uF	KETSU
LC04 - LC06	(RA) 23221141 (RB) 23221139	TRF9240AC TRF9240AH

	Z101	Z102	C104	GJ03	GJ04	GJ05	GJ06	GJ07
NICAM	(RA) BSF6284 (RB) K6284K	(RA) BSF9351 (RB) K9351K	10uF	SHORT	KETSU	SHORT	KETSU	KETSU
AV STEREO	(R1) TSF6380Y (R2) K6269K (R3) F816K	KETSU	KETSU	SHORT	KETSU	KETSU	KETSU	SHORT
MONO BILINGUAL	K2984M	KETSU	KETSU	SHORT	KETSU	SHORT	KETSU	KETSU

MODEL	CC20
"M", "R"	15p
OTHER MODELS	KETSU

PRE AMP	GJ17
NOT USED	SHORT
USED	KETSU

LOCATION	MULTI	THAI BILINGUAL
D103	(RA) KDS114 (RB) MA77	KETSU
R111	3K	KETSU
R112	10K	KETSU
R113	3.3K	KETSU
R110	10K	KETSU
R117	15K	KETSU
R118	100R	KETSU
Q107 - Q108	(RA) SRC1202U (RB) KRC402 (RC) DTC114EUA	KETSU

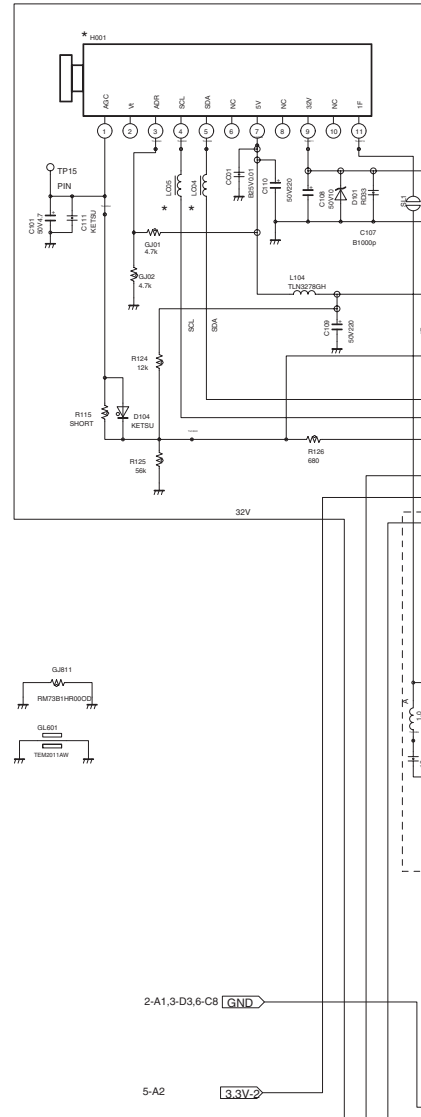

SCHEMATIC DIAGRAM MODEL :

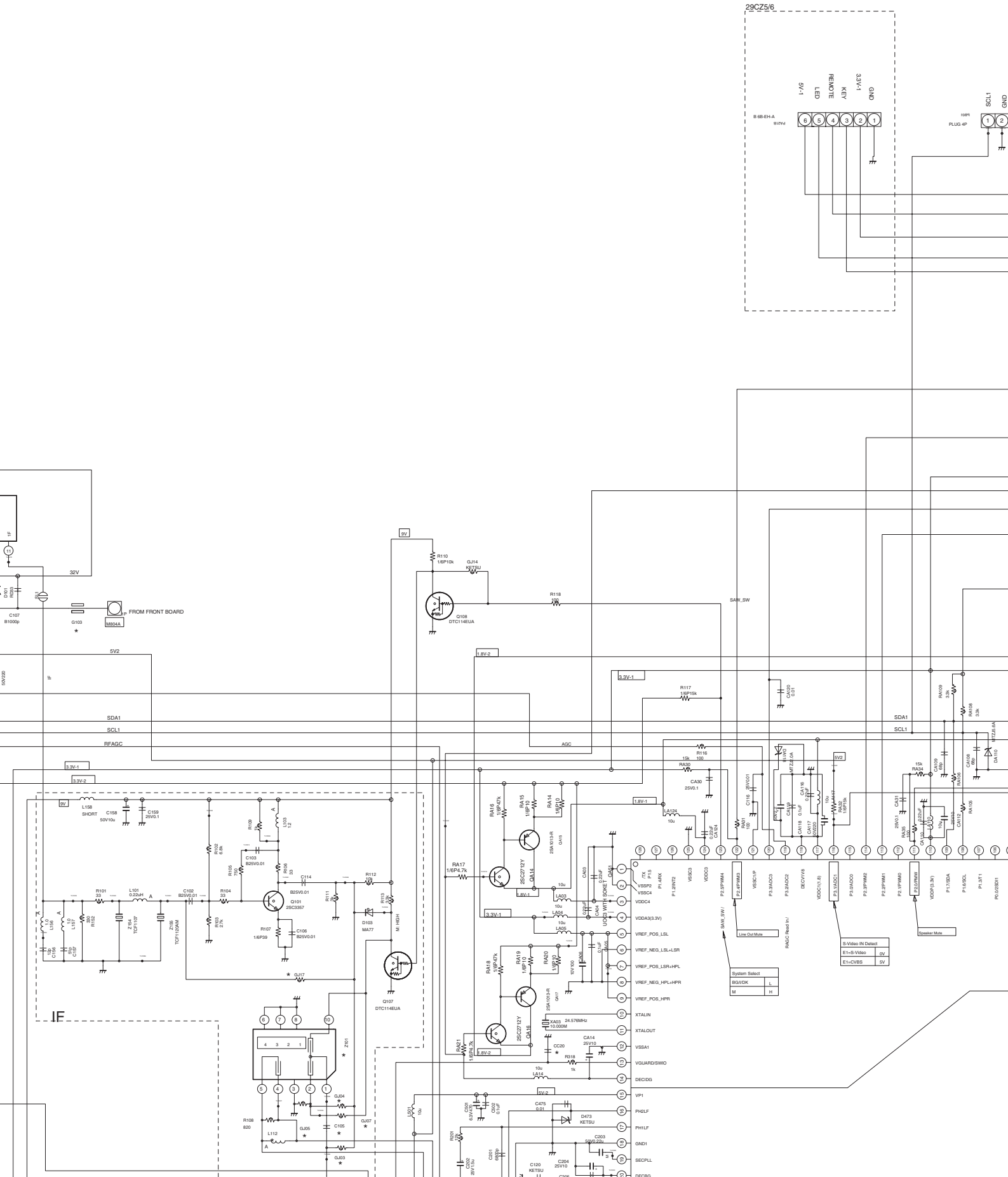

EL : 29CZ5DE/29CZ5T/29CZ6SI (1/8)

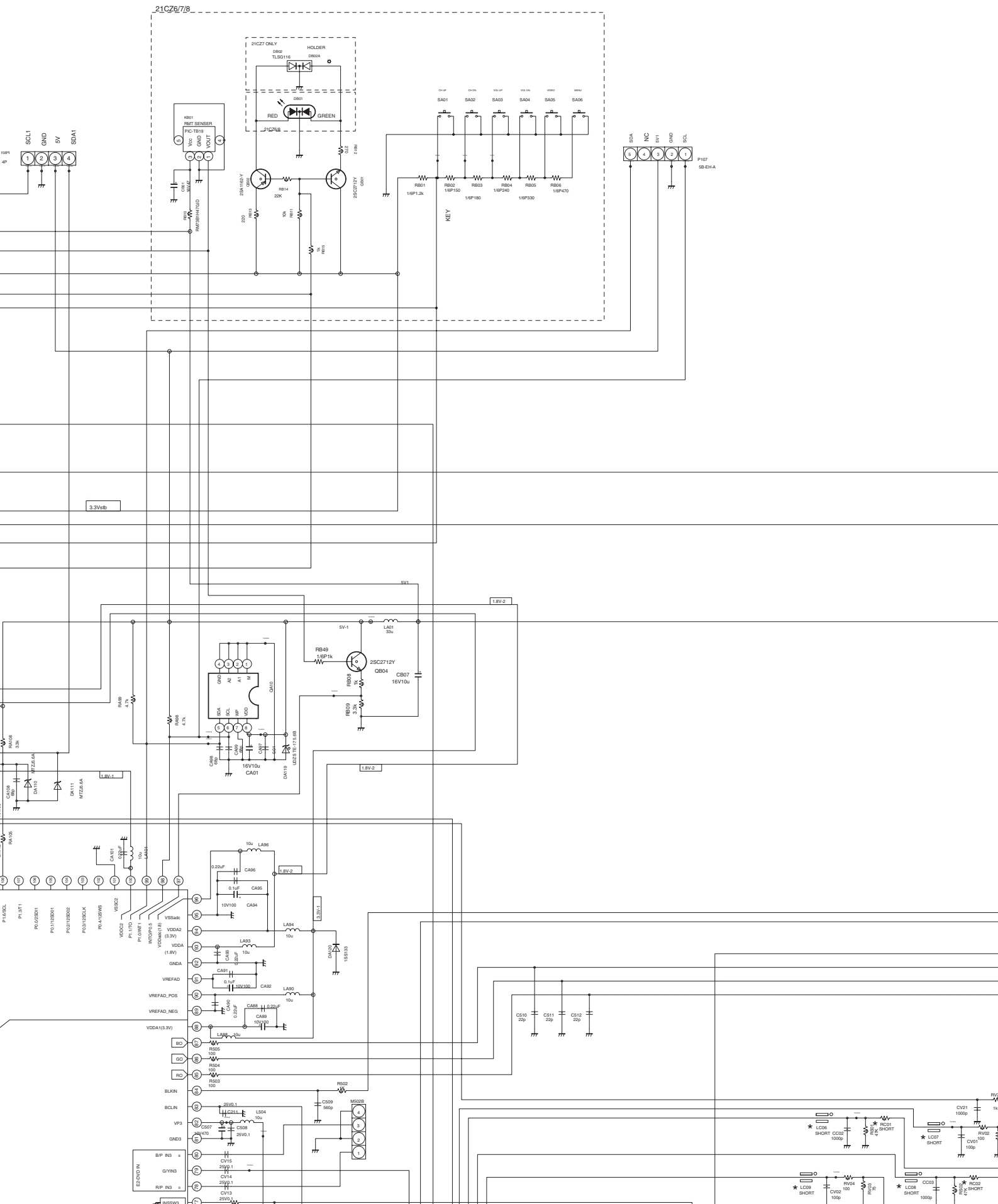

G

R117		15K	KETSU
R118		100R	KETSU
Q107 - Q108	(RA)	SPRC1202U	KETSU
	(RB)	KRC402	
	(RC)	DTC114EUA	
C140		KETSU	47pF
C141		KETSU	10nF
C142		KETSU	10nF
C144		KETSU	10uF
C145		KETSU	100nF
C130		KETSU	KETSU
R140		KETSU	100R
R141		KETSU	2.2k
R142		KETSU	1k
R123		KETSU	100R
L109		KETSU	12uH
L110		KETSU	10uH
Q102		KETSU	(RA) KTC4075Y
			(RB) 2SC4116Y
			(RC) 2SC4081T
Z104		KETSU	EFC55R74YSST

H

POWER (MAIN BOARD) [21CZ6-8 MODELS]

LOCATION		RUSSIA MODEL	OTHER MODEL
G104 - G105	(RA)	23248423	TLN3481AC
	(RB)	23248386	TLN3481AA
	(RB)	23248417	TLN3481AH
G106 - G109	(RA)	23103308	TEM2011AO
	(RB)	23103302	TEM2011AH
GJ32 - GJ43		KETSU	SHORT

I

J

K

L

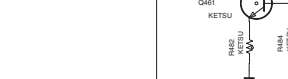
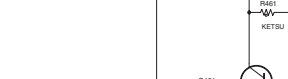
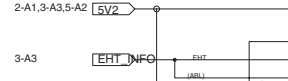
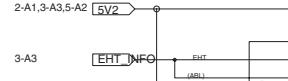
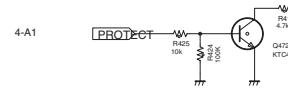
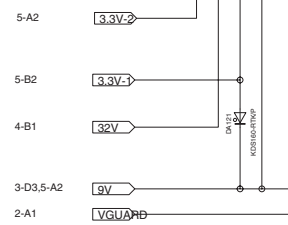

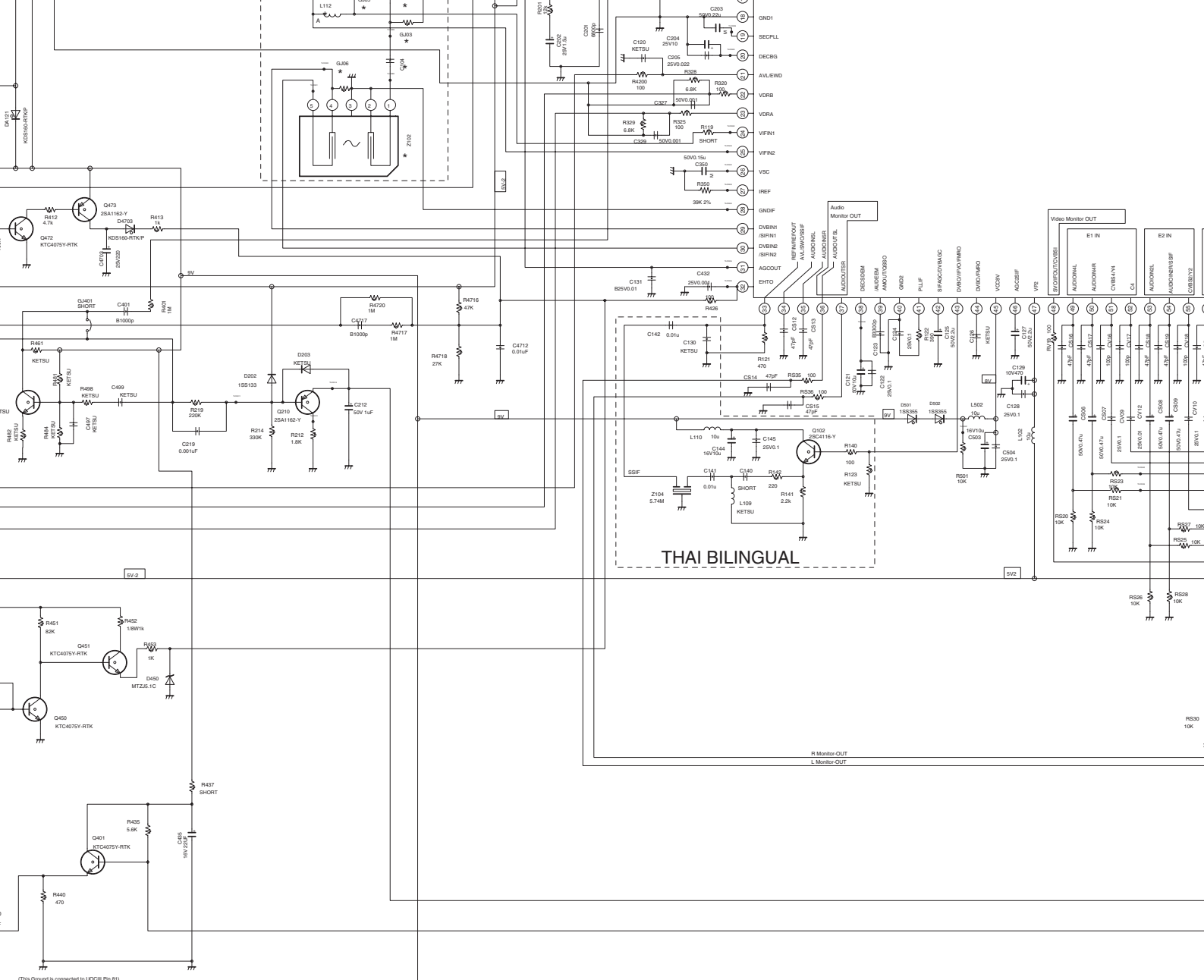

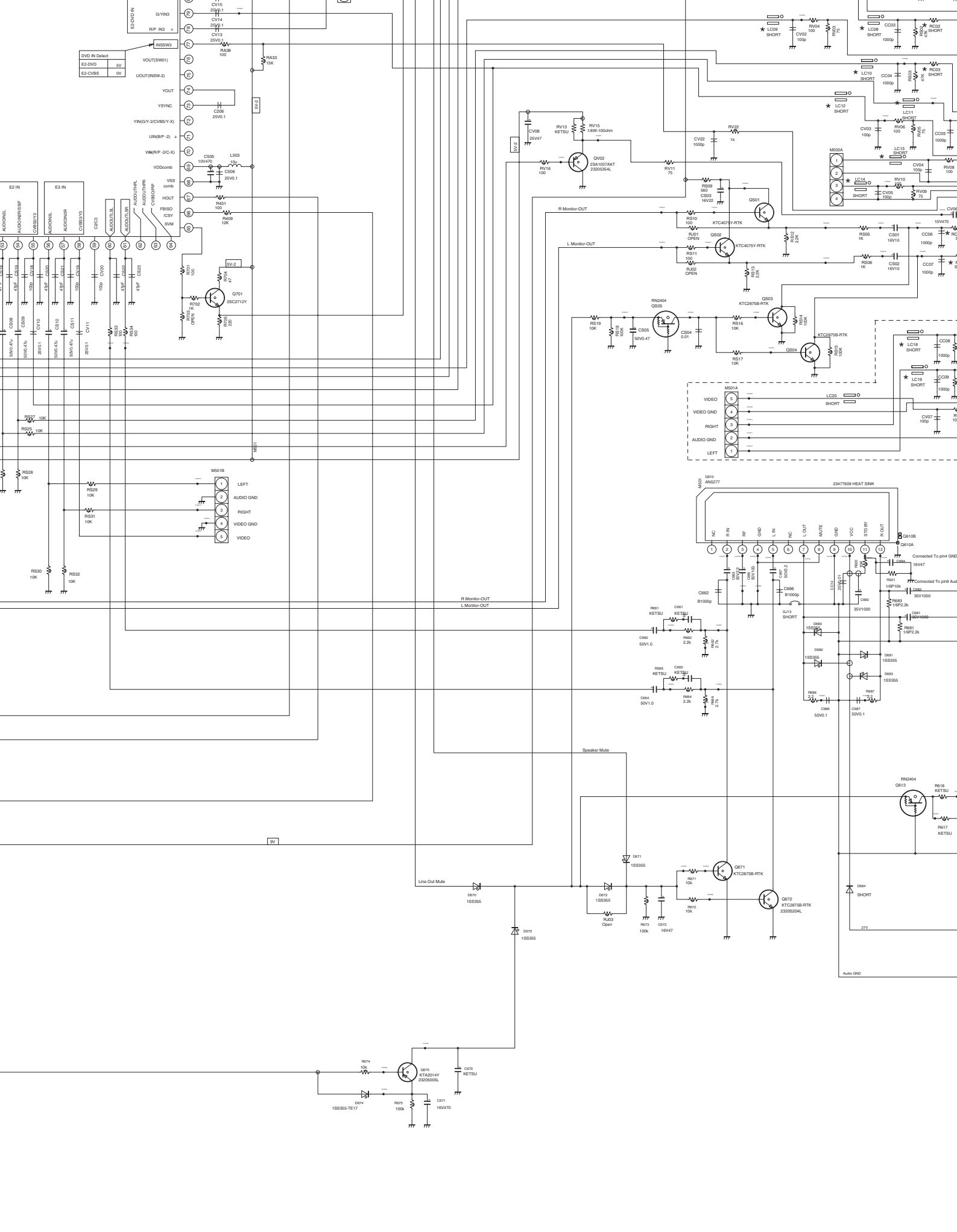

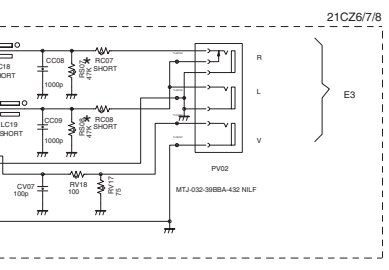
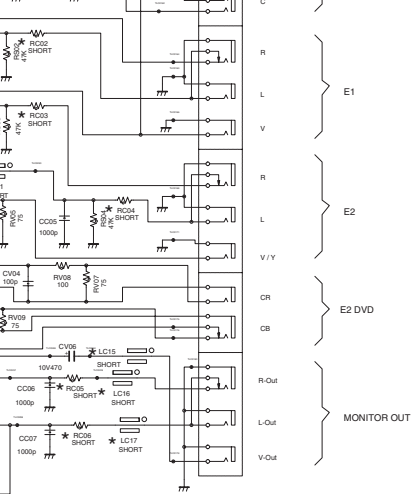

LOCATION	21CZ6/7/8	29CZ5/6
P661	HEAD PHONE JACK	KETSU
GJ21 - GJ22	KETSU	SHORT
RS61- RS62	270	KETSU

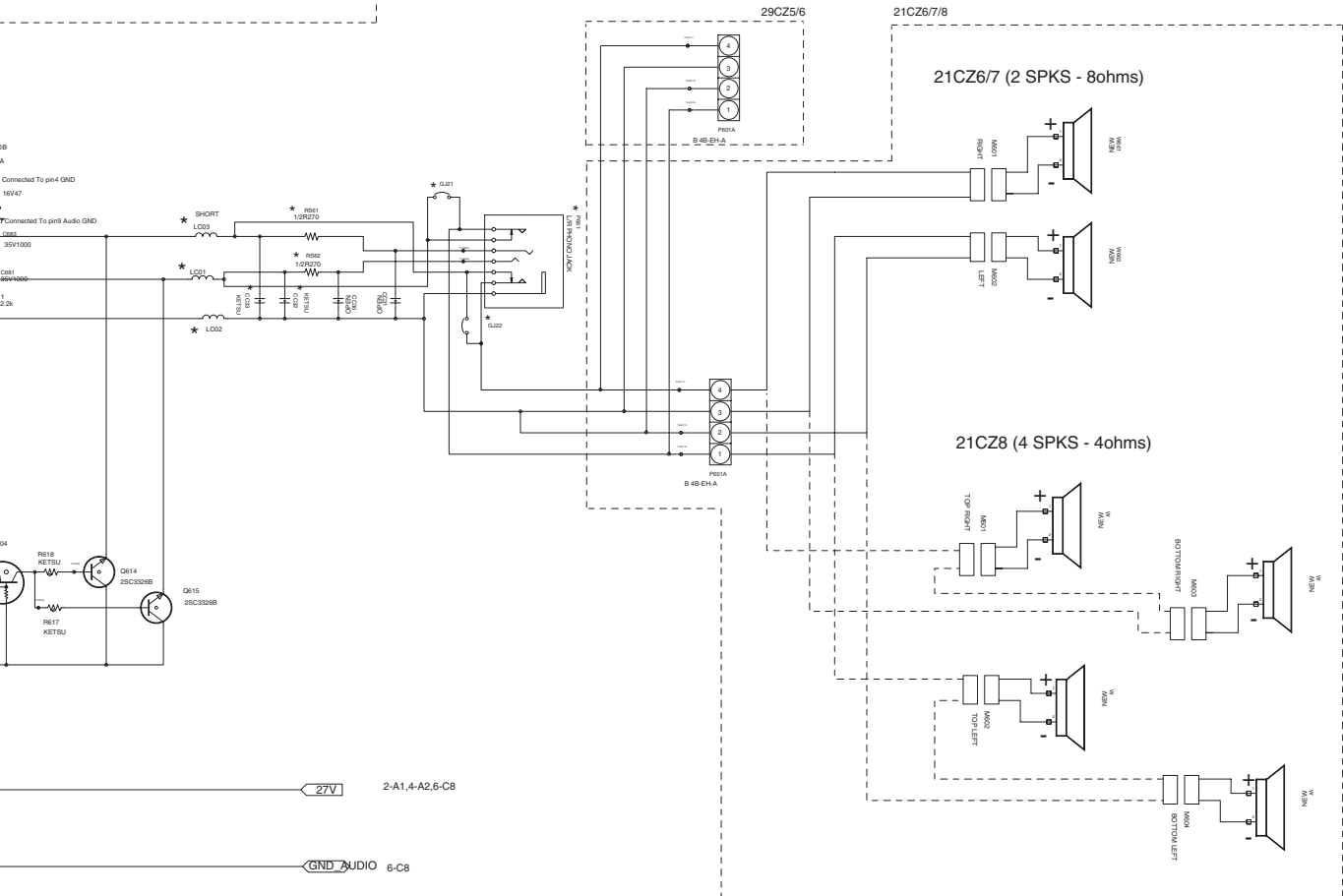

29CZ5DE/29CZ5T/29CZ6SI
 MAIN (SIGNAL/MICON)
 [SHEET-1/6]

SCHEMATIC DIAGRAM MODEL : 29CZ5DE/29CZ5T/29CZ6SI (2/8)

1

2

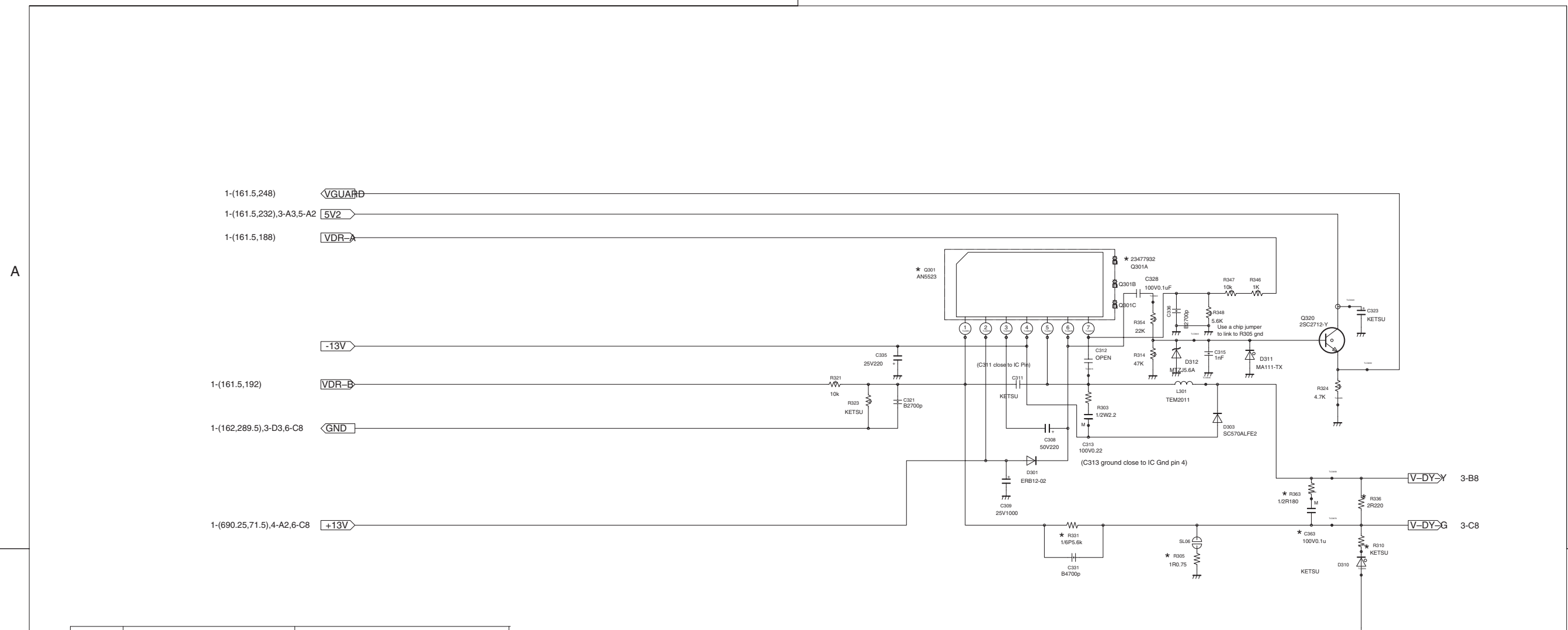

A

A

B

B

*	29CZ5	21CZ6/7/8
C363	M100V0.1uF	
Q301	AN5523	
Q301A	23478144	
R305	1W1R	
R345	2R1K	
R329	1/4P10K	
R330	1/4P33K	
R331	1/4P15K	
R336	2R100	
R363	1/2R180	

29CZ5DE/29CZ5T/29CZ6SI
MAIN (VERT)
[SHEET-2/6]

1

2

SCHEMATIC DIAGRAM MODEL : 29CZ5DE/29CZ5T/29CZ6SI (3/8)

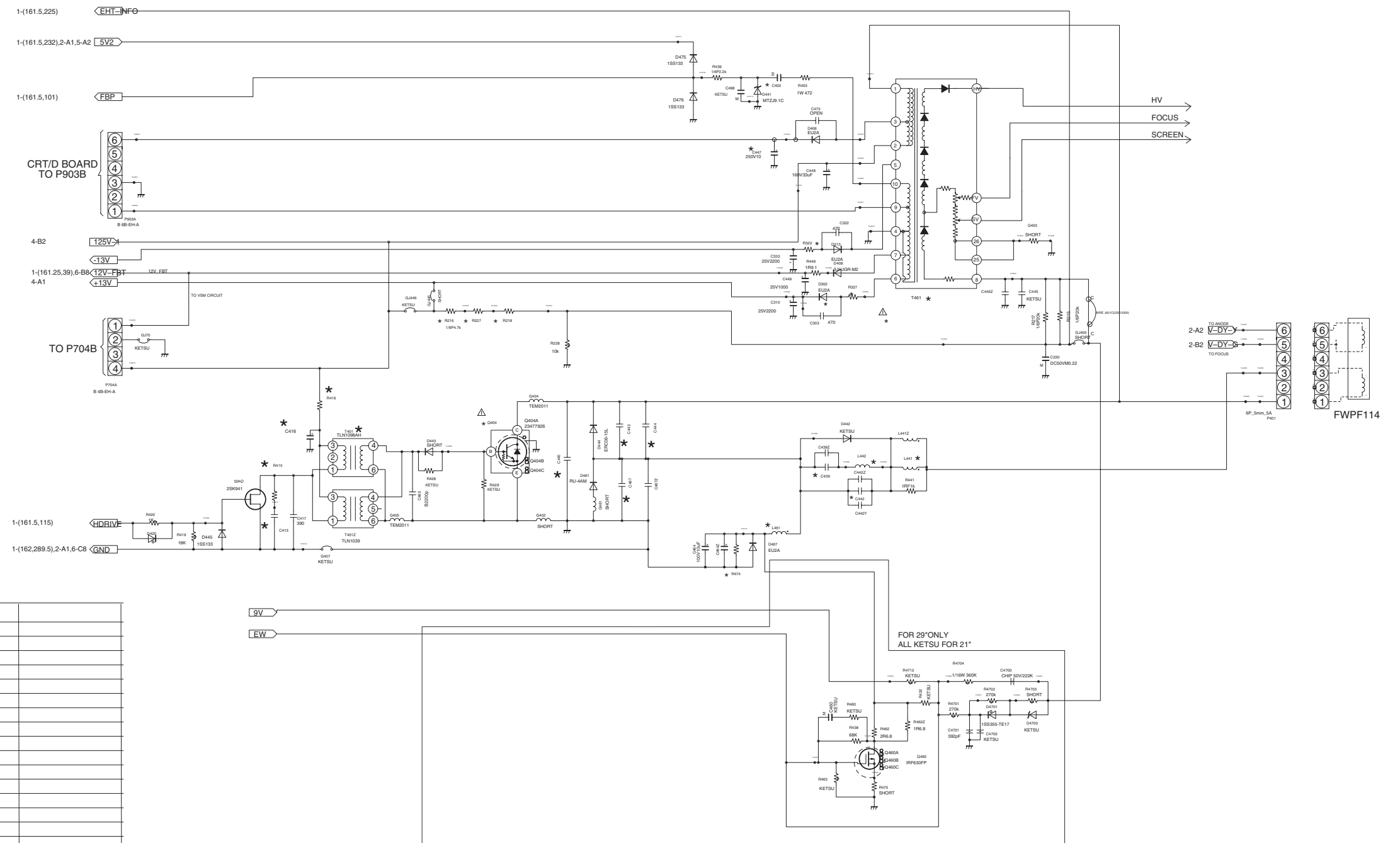

	29CZ5	21CZ 6/7/8
C402	76693472D 100V/472	76693472D 100V/472
C439	76503125B CAP 400V/753J	KETSU
C440	KETSU	76503213B 1.5KV/152
C442	76503298B 315V/304J	76082995B 250V/364
C443	76503194B 1.5KV 103H	KETSU
C444	76503225B 1.5KV 622H	76503274B 1.5KV/782
C464	7621222A(RA)/76640872E(RB)	76640872E 100V/10uF
C467	76503160B 630V 433J	76503157B 630V/333
L441(RA)	23233132 TLN2083AH	23233113 TLN2210AA
L441(RB)	23233124 TLN2083AT	23233147 TLN2210AC
L441(RC)	23211848 TLN2083G	23233145 TLN2210AY
L442	23248404 TLN3383D	KETSU
L461(RA)	23248375 TLN3335AA	23248410 TLN3337AD
L461(RB)	23248409 TLN3335AD	23248460 TLN3337AC
L461(RC)	23248459 TLN3335AC	23248376 TLN3337AA
R218	23183918 WIRE JUMPER	76366472Y 1/6W/64.7K
R227	76366392Y 1/6W/3.9K	76366472Y 1/6W/64.7K
R216	76366103Y 1/6W/10K	76366332Y 1/6W/63.3K
R322	76182030L ERX1FJ4R7H	76182011L ERX1SJS4R7P
R327	76182030L ERX1FJ4R7H	76182011L ERX1SJS4R7P
R474 (R1)	KETSU	KETSU
R474 (R2)	KETSU	76383271S
R474 (R3)	KETSU	76383221S
T401(RA)	23224395 TLN1098GH	23224391 TLN1104AH
T401(RB)	TLN1098AH	23224404 TLN1039
T461(RA)	23236963 TFB4229AG	23236962 TFB4228AT
T461(RB)	23236957 TFB4228AS	23236957 TFB4228AS
C447	76679220S 250V/22UF	76679100S 250V/10UF
R415	76553272L 1W/272	KETSU
C413	76214821A CERA 500V/821K	KETSU
R416	76019323 5W 182J	(RA)/76019329 (RB)/76510332 5W 332J
C416	76678479S 200V 4.7UF	KETSU
C440		

29CZ5DE/29CZ5T/29CZ6SI
MAIN (HORIZONTAL)
[SHEET-3/6]

SCHEMATIC DIAGRAM MODEL : 29CZ5DE/29CZ5T/29CZ6SI (4/8)

1

2

A

A

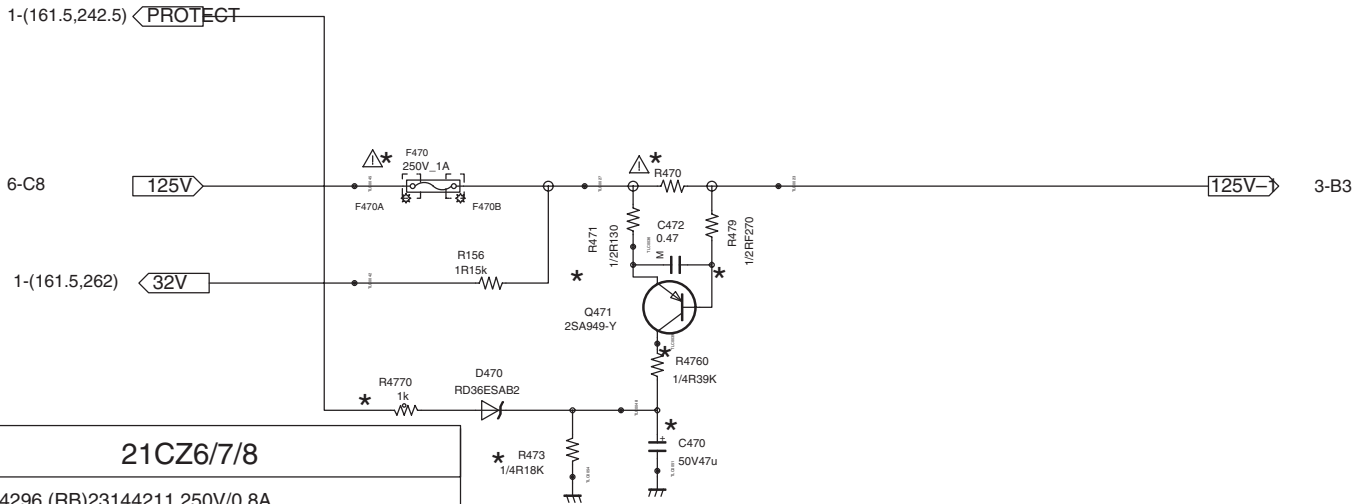

*	29CZ5	21CZ6/7/8
F470	(RA)23144297(RB)23144210 250V 1A	(RA)23144296 (RB)23144211 250V/0.8A
R470	76182018L ERX1FJR47H	76182021L ERX1FJR75H
R471	76381131L 1/2 W 130	76382121S 1W121
R479	76381271L RS14B2H271J	76552301L 1/2W 301
R4760	76000242Y 1/4W 18K	76366183Y 1/6W 183
R473	76000247Y RN14C2E393F	76366183Y 1/6W 183
R4770	76011102R RM73M1J102JD	76011102R 1/16W 102
C470	(RA)76766101S(RB)76797101S 50V/100UF	(RA)76766470S (RB)76797470S 50V/47UF

B

B

29CZ5DE/29CZ5T/29CZ6SI
MAIN (PROTECTOR)
[SHEET-4/6]

1

2

SCHEMATIC DIAGRAM MODEL : 29CZ5DE/29CZ5T/29CZ6SI (5/8)

1

2

A

A

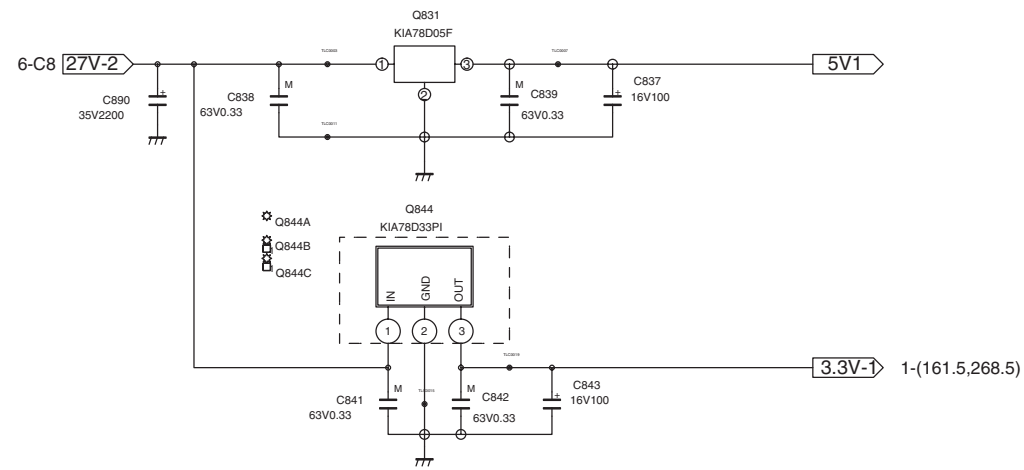
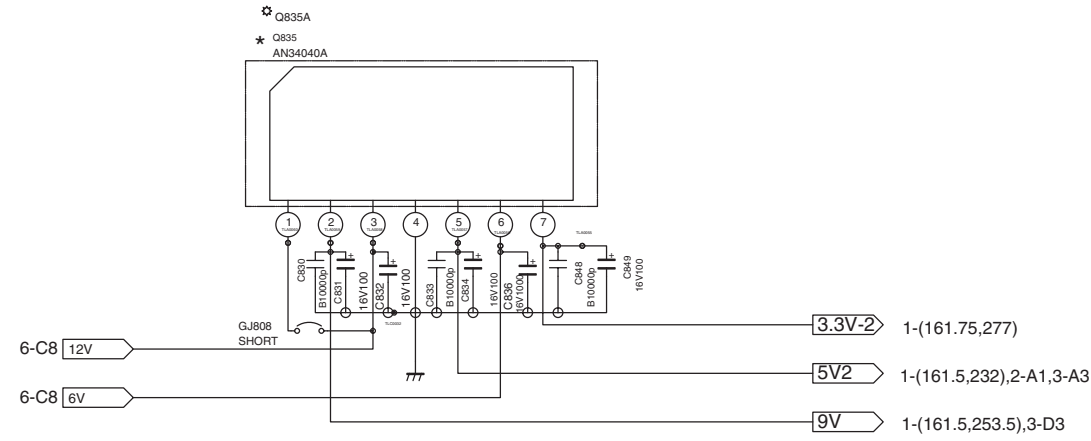

B

B

29CZ5DE/29CZ5T/29CZ6SI
MAIN (LOW B REG)
[SHEET-5/6]

1

2

SCHEMATIC DIAGRAM MODEL : 29CZ5DE/29CZ5T/29CZ6SI (6/8)



Russia Model Only

	21CZ6/7/8	29CZ5
GJ32		
GJ33		
G104		
GJ34		
GJ35		
G105		
GJ36		
GJ37		
G106		
GJ38		
GJ39		
G107		
GJ40		
GJ41		
G107		
GJ42		
GJ43		
G108		
Q801	STR-F6267S	STR-F6268S
Q801A	HEATSINK	HEATSINK(65mm)

POWER CORD

ASIA	250V 2.5A
EAST EUROPE	250V 2.5A
HONG KONG	250V 13A/10A
MIDDLE EAST	NON SASO 250V 2.5A
	SASO 250V 13A/10A
AUSTRALIA	250V 7.5A/10A
TAIWAN	125V 7A
THAILAND	250V 6A

**29CZ5DE/29CZ5T/29CZ6SI
MAIN (POWER)
[SHEET-6/6]**

SCHEMATIC DIAGRAM MODEL : 29CZ5DE/29CZ5T/29CZ6SI (7/8)

CRT-Drive BOARD

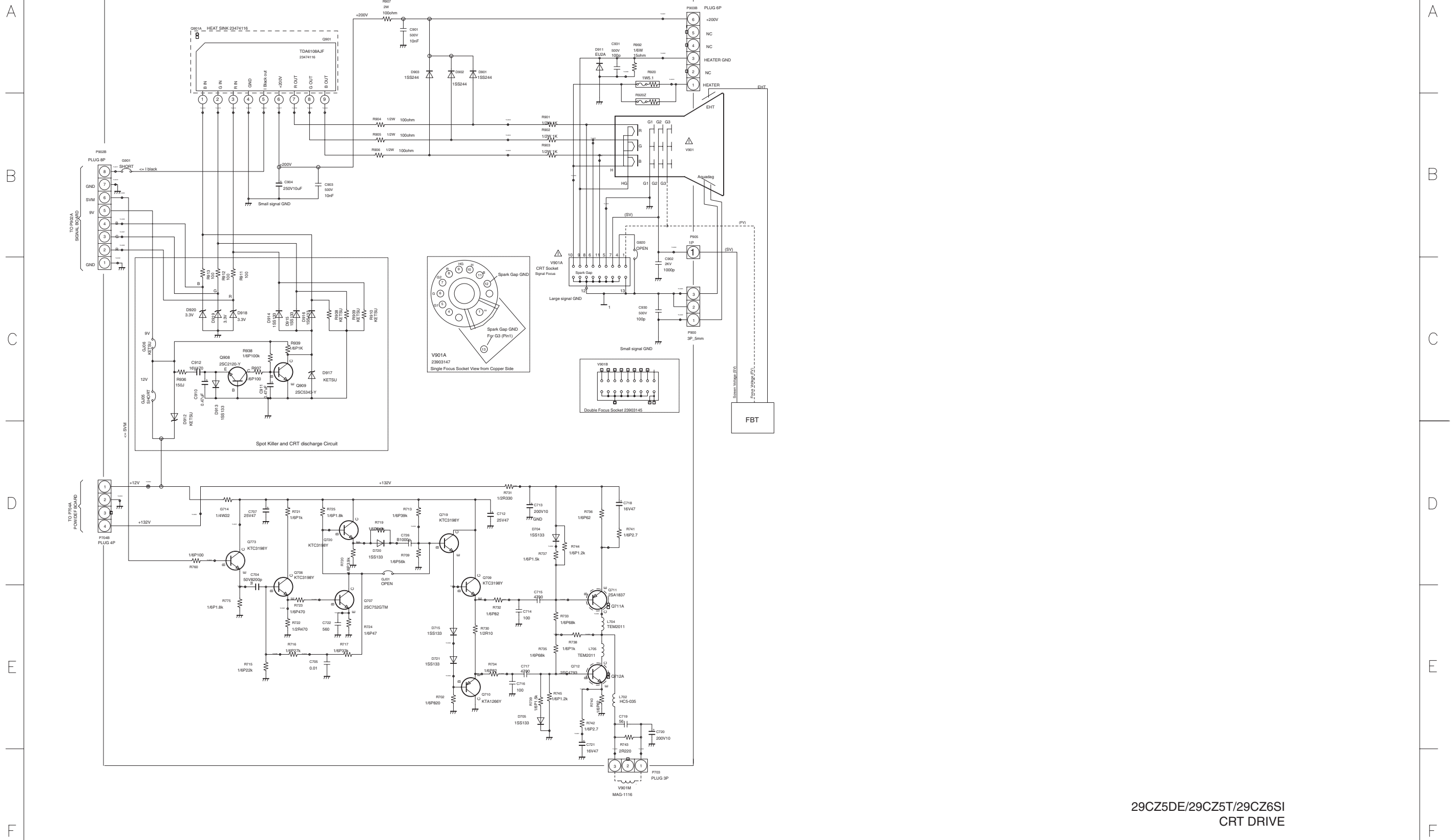

29CZ5DE/29CZ5T/29CZ6SI
CRT DRIVE

SCHEMATIC DIAGRAM MODEL : 29CZ5DE/29CZ5T/29CZ6SI (8/8)

1

2

A

A

B

B

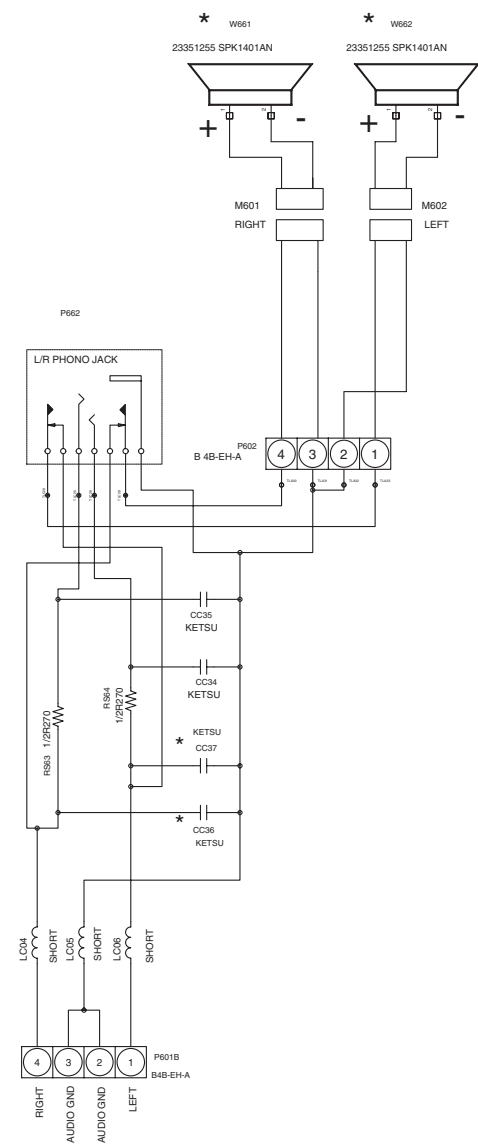
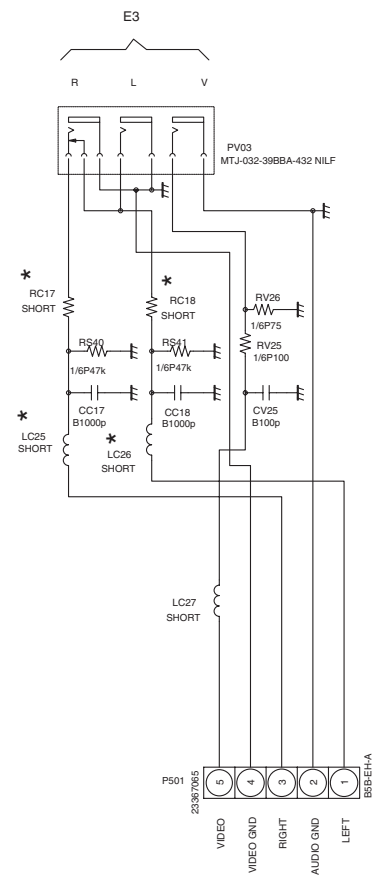
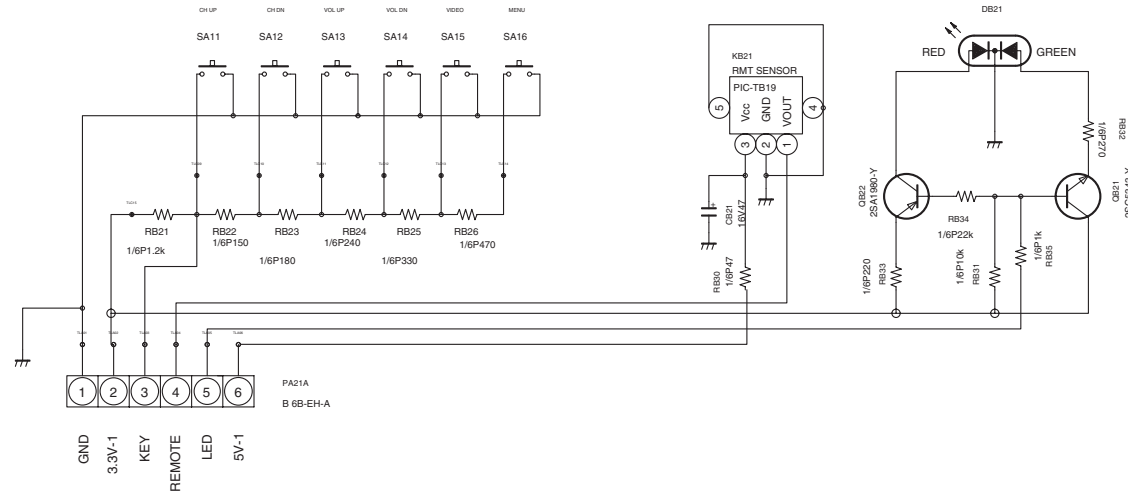

29CZ5DE/29CZ5T/29CZ6SI
FRONT

1

2