

WARING PRO™

MEAT GRINDER



MG100

For your safety and continued enjoyment of this product,
always read the instruction book carefully before using.

INSTRUCTION MANUAL

IMPORTANT SAFEGUARDS

When using electrical appliances, basic safety precautions should always be followed, including the following.

1. **READ ALL INSTRUCTIONS.**
2. To protect against risk of electrical shock, do not put appliance in water or other liquid.
3. Close supervision is necessary when any appliance is used by or near children. This appliance is not recommended for use by children.
4. Unplug from outlet when not in use, before putting on or taking off parts, and before cleaning.
5. Avoid contacting moving parts.
6. Never put the unit near a hot burner, in an oven, or in a dishwasher.
7. Do not operate the Waring Pro™ Meat Grinder, or any other electrical equipment, with a damaged cord or plug or after the appliance malfunctions, or is dropped or damaged in any manner. Return to the nearest authorized service centre for examination, repair, or adjustment.
8. **NEVER FEED FOOD BY HAND; ALWAYS USE THE PUSHER.** Keep hands, hair, clothing and utensils away from moving discs during operation to reduce the risk of personal injury and/or damage to the Waring Pro™ Meat Grinder.
9. Do not use outdoors, or use for other than intended use.
10. **Warning-** the cutting blade is sharp; handle with care both when using and when cleaning.
11. Do not let cord hang over edge of table or counter, contact sharp edges, or touch hot surfaces.
12. Do not pull on the power cord to disconnect.
13. Never plug in the appliance where water may flood the area.
14. Place the appliance on a firm and stable surface.
15. **NEVER PUT YOUR FINGERS NEAR THE FOOD CHUTE WHILE GRINDER IS IN OPERATION.**
16. Ensure that the appliance is not placed close to the edge of the table, worktop, etc. where it can be pushed off or fall.
17. The use of attachments not recommended or sold by the manufacturer may cause fire, electric shock or injury.
18. Never use abrasive cleaning agents or abrasive cloths when cleaning the unit.
19. Do not use fingers to scrape food away from Cutting Blade while appliance is in operation. Cut type injury may result.
20. Only use the unit when completely assembled.

21. Do not leave the Waring Pro™ Meat Grinder unattended while it is running.
22. Before using for the first time, remove all packaging and wash parts.
23. This appliance has a polarized plug (one blade is wider than the other). To reduce the risk of electric shock, this plug will fit in a polarized outlet only one way. If the plug does not fit the outlet perfectly, reverse the plug. If it should still not fit, contact a qualified electrician. Do not modify the plug in any way.

FOR HOUSEHOLD USE ONLY SAVE THESE INSTRUCTIONS

PARTS

- | | |
|--------------------------|--------------------------------|
| 1. On/Off/Reverse Switch | 9. Cutting Blade |
| 2. Locking Knob | 10. Cutting Plate (fine) |
| 3. Motor Housing | 11. Cutting Plate (medium) |
| 4. Attachment Opening | 12. Cutting Plate (coarse) |
| 5. Food Pusher | 13. Sausage Attachment (small) |
| 6. Die-Cast Hopper | 14. Sausage Attachment (large) |
| 7. Grinder/Feeder Head | 15. Screwing Ring |
| 8. Feed Screw | |

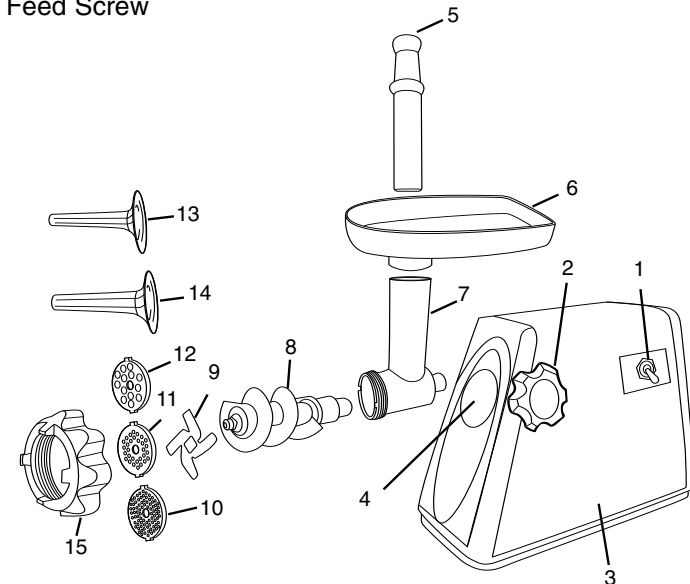

ASSEMBLING

1. Make sure unit is unplugged while assembling.
2. Place Grinder/Feeder Head tightly into Attachment Opening. Holding Head with one hand, place Locking Knob into the hole on the side of the Motor Housing and tighten knob by turning clockwise.
3. Place Feed Screw into Grinder Tube, long end spindle first; turn it slightly until it is set into Motor Housing.
4. NOTE: Position Cutting Blade onto Feed Screw shaft with the flat cutting surface facing out from the Feed Screw. If it is not fitted properly, meat will not be ground and the cutting plate may be permanently damaged.
5. Position the desired Cutting Plate onto the flat sides of the Cutting Blade. Ensure that the two locking tabs of the Cutting Plate fit into the slots of the Grinder/Feeder Head.
6. Secure Screw Ring to the end of the Grinder/Feeder Head by turning clockwise.
7. Place Die-Cast Hopper on the Grinder/Feeder Head.

HOW TO USE

1. Before first use, wash all parts of the Waring Pro™ Meat Grinder.
2. Place the Waring Pro™ Meat Grinder on a stable work surface.
3. Make sure the On/Off/Reverse Switch is in the “Off” position.
4. Insert plug into wall outlet.
5. Place a wide, shallow bowl or plate beneath the grinder tube to catch food.
6. Switch appliance to “On” position. The Waring Pro™ Meat Grinder must ALWAYS be “On” before adding food.
7. Cut food into strips or cubes slightly smaller than the opening on the Die-Cast Hopper.
8. Place food on the Die-Cast Hopper and use Pusher to feed food through opening.
9. Use the Food Pusher to gently feed food, one piece at a time. Do not force the food into the Grinder/Feeder Head.

NOTE - REVERSE SWITCH

If the motor slows or stops, this may be due to jammed food. Immediately switch the Waring Pro™ to its “Off” position. Press the Reverse Switch to push the food in the opposite direction. Release the Reverse Switch and turn the Meat Grinder “On” again. If the Meat Grinder should get jammed again, you may need to switch it “Off”, Unplug, disassemble the Grinder Head, and clean the internal parts.

CUTTING PLATES

Fine Cutting Plate- Great for spreads, patés, baby food, and hamburgers

Medium Cutting Plate- Great for ground meat used in soups, or for relishes

Coarse Cutting Plate- Great for ground meat used in chili, or for vegetables

THESE PLATES ARE NOT DISHWASHER SAFE. PLEASE HAND-WASH ONLY!

HELPFUL HINTS

- Grinding stale bread pieces may help remove food residue left in the Waring Pro™ Meat Grinder after use.
- Cut food into strips or cubes slightly smaller than the opening on the Die-Cast Hopper.
- Make sure food is free of bone, tough tendon, nutshells, etc. before grinding.
- Raw meat and fish should be thoroughly chilled (not frozen) before grinding to reduce the loss of juices. Freshly ground meat should be refrigerated and cooked within 24 hours.
- During extended grinding, fats from meats can build up inside the grinder tube, slowing down grinding and straining the motor. If this happens, you should stop the Waring Pro™ Meat Grinder, wash parts in hot water, and reassemble. When possible, alternate bread with meat. This helps keep the feed screw clean.
- Trim a handful of fat from meat. Process the fat through the hopper to lubricate grinding mechanism for better processing results.
- For best drying results, prepare sausage a day or two prior to use.

TO MAKE SAUSAGES

The sausage attachments allow you to blend meats and spices for homemade sausages.

METHOD #1

- * If you have purchased dry casings, they must be soaked in cold water, or a mixture of 2 cups water and 1 tablespoon of vinegar, until they become soft and pliable. Soak for approximately 1 hour changing water 3 times to rinse salt off.
- * Meats should be cut into cubes that will fit through the Die Cast Hopper opening and mixed with seasonings before making sausages.

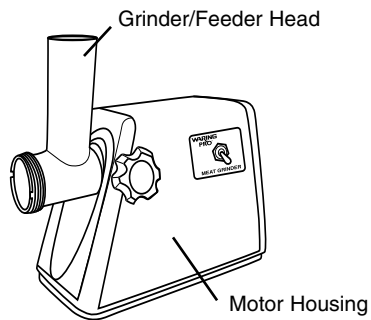

1. Assemble Grinder/Feeder Head to Motor Housing.

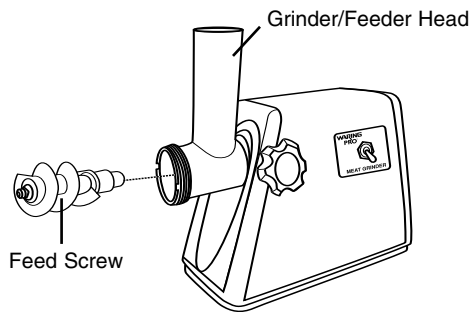

2. Insert Feed Screw into the Grinder/Feeder Head.

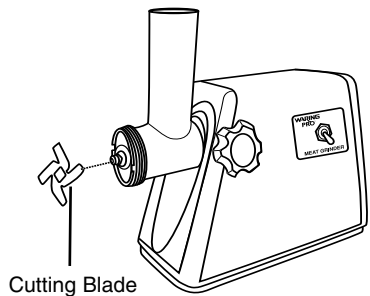

3. Assemble Cutting Blade on the end of the Feed Screw.

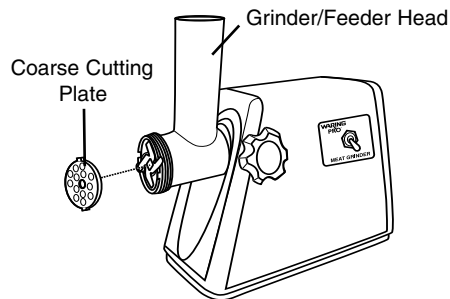

4. Place the coarse Cutting Plate in the Grinder/Feeder Head.

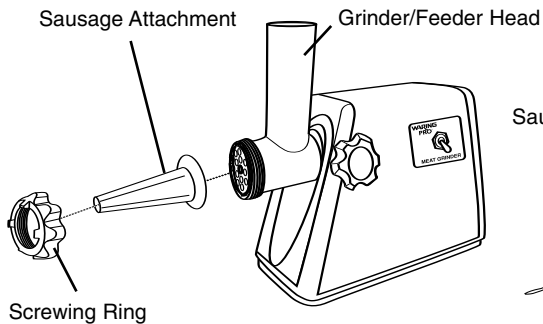

5. Put the desired Sausage Attachment (small or large) into the Screwing Ring and screw onto the Grinder/Feeder Head.

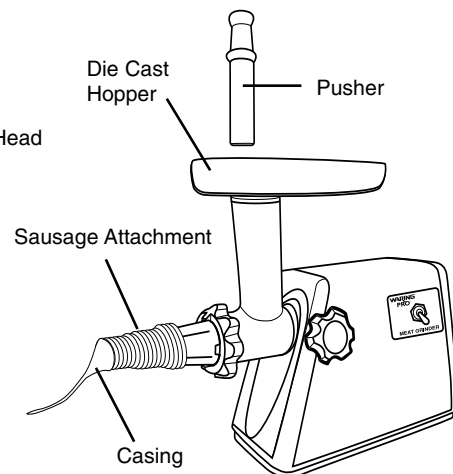

6. Slide casing all the way to the end of the Sausage Attachment, leaving approximately 2" overhanging the end of the Sausage Attachment.

7. Place seasoned meat cubes into the Die Cast Hopper and turn the unit "ON". Push the meat cubes in the Die Cast Hopper opening with Pusher until the mixture appears at the end of the Sausage Attachment. Turn the unit "OFF" and tie a knot at the end of the 2" (5 cm) casing overhang.
8. Turn unit "ON" and feed the meat cubes into the Die Cast Hopper opening until all the meat cubes have been used or the casing is approximately 2" (5 cm) from being completely full.
9. Turn unit "OFF", Remove the end of the casing from the Sausage attachment, and tie a knot in the open end of the casing. If air bubbles have formed, use a knife or needle to burst.
10. Sausages can be made to the desired length by twisting the casing at intervals.

NOTE: To avoid over-stretching and splitting the casing, do not make the sausages too thick. The meat mixture will expand slightly during cooking. Keep casing moist, water frequently. Meat can be seasoned before or after grinding.

METHOD #2

1. Pre-grind seasoned meat cubes.
2. Follow steps 5 to 10 from method #1.

CLEAN AND CARE

- Always unplug motor unit when not in use, before inserting or removing parts, and before cleaning.
- Never immerse power unit in water or other liquid.
- Wash all parts except motor unit in hot soapy water, using care when handling the sharp blades.
- Rinse these parts with clear hot water, then dry. REMOVABLE PARTS ARE NOT DISHWASHER SAFE!
- Wipe motor unit with a damp cloth. Do not use harsh or abrasive cleaners.
- Cutting blade and cutting plate should be coated with cooking oil after washing and then wrapped in grease-proof paper to keep them lubricated and rust-free.

RECIPES

Chicken, Feta & Spinach Sausage

Makes 5 pounds sausage

- 3 pounds boneless, skinless chicken thighs**
- 1 pound boneless, skinless chicken breast**
- 8 ounces crumbled feta cheese**
- 4 cloves garlic, peeled and minced**
- 1 tablespoon oregano**
- 2 teaspoons basil**
- 1 teaspoon chopped lemon zest**
- 2 teaspoons kosher salt**
- 1 teaspoon freshly ground black pepper**
- 1/2 teaspoon red pepper flakes**
- 4 ounces fresh spinach, shredded/chopped**

Remove gristle, cartilage and large amounts of excess fat from the chicken, cut into 1 - inch cubes. Place chicken in a large bowl. Add feta cheese, garlic, oregano, basil, lemon zest, salt, pepper, and pepper flakes to chicken. Stir to combine. Mixture can be ground immediately, or covered and refrigerated for up to 24 hours for a more intense flavor. Just before grinding, stir shredded spinach into chicken mixture.

Assemble Waring Pro™ Meat Grinder with the Medium Cutting Plate. Grind chicken mixture with the medium cutting plate of the Waring Pro™ Meat Grinder. Sausage may be stuffed into prepared casings or shaped into patties for cooking. Fresh sausage should be cooked within 24 hours or double wrapped and frozen. Cook thoroughly before serving - internal temperature should register 170° F when tested with an instant read thermometer.

Nutritional information per suggested serving:

Calories 213 (46% from fat) • carb. 1g • pro. 27g • fat 11g • sat. fat 4g chol 94mg • sod. 341mg • calc. 81mg • fiber 0g

Italian Fennel Sausage

Makes 4 pounds sausage

- 4 pounds pork butt**
- 6 cloves garlic, peeled and minced**
- 1/4 cup Italian parsley leaves, packed**
- 1-1/2 tablespoons fennel seeds, crushed**
- 1/2 tablespoon oregano**
- 2 teaspoons kosher salt**
- 2 teaspoons freshly ground pepper**

Remove any gristle from meat. Cut into 1 - inch cubes. Place meat in a large bowl and combine with remaining ingredients. Cover and refrigerate for at least 8 and up to 24 hours for best flavor.

Assemble Waring Pro™ Meat Grinder with Fine or Medium Cutting Plate. Grind sausage. Stuff sausage into prepared casings, form into patties or leave loose as needed. Fresh sausage should be cooked within 24 hours or double wrapped and frozen. Cook thoroughly before serving - internal temperature should register 160° F when tested with an instant read thermometer.

Nutritional information per suggested serving:

Calories 183 (48% from fat) • carb. 1g • pro. 22g • fat 9g • sat. fat 3g chol. 73mg • sod.244 • calc. 39mg • fiber 0g

Andouille Sausage

With its distinctly smoky flavor, traditional Andouille sausage is a staple of Cajun cookery and an important ingredient in jambalayas and gumbos. The unsmoked version is made in smaller links and is known as Andouillette.

Makes 3 pounds

- 3 pounds boneless pork butt (may substitute half turkey for a lighter sausage)**
- 4 - 6 large cloves garlic, peeled and minced**
- 1 teaspoon browning sauce such as Gravy Master™**

- 2 teaspoons kosher salt**
- 2 tablespoons sweet paprika**
- 1/2-1 tablespoon cayenne pepper, to taste**
- 1 tablespoon onion powder**
- 2 teaspoons dry thyme**
- 1/2 teaspoon freshly ground black pepper**
- 1/2 teaspoon crushed red pepper**
- 1/2 teaspoon rubbed sage**
- 1/8 teaspoon allspice**

Remove any gristle from meat. Cut into 1 - inch cubes. Place meat in a large bowl and combine with remaining ingredients. Cover and refrigerate for at least 12 and up to 24 hours for best flavor.

Assemble Waring Pro™ Meat Grinder with Medium or Large Cutting Plate. Grind sausage. Stuff sausage into prepared casings tying off links into desired lengths. Sausage may then be smoked in a homestyle smoker. Recommended smoking temperature is 175° - 200° F, and smoking time should be 4 to 6 hours. Suggested woods for smoking Andouille are pecan or hickory. Cook thoroughly before serving - internal temperature should register 160° F when tested with an instant read thermometer. The andouille may then be used as is, sliced thinly as an hors d'oeuvre, or as an ingredient in jambalaya, gumbo or other Cajun dish. Smoked Andouille may be frozen.

Nutritional information per suggested serving:
Calories 339 (66% from fat) • carb. 2g • pro. 27g • fat 24g • sat. fat 9g chol. 68mg • sod. 300mg • calc. 25mg • fiber 0g

Country Breakfast Sausage

Pork is paired with turkey to make this breakfast favourite a little lighter.

Makes 4 pounds sausage

- 2 pounds boneless, skinless turkey thighs**
- 2 pounds boneless pork butt**
- 1 tablespoon browning sauce, such as Gravy Master™**
- 1 teaspoon kosher salt**

- 1-1/2 tablespoons rubbed sage**
- 2 teaspoons freshly ground black pepper**
- 1 teaspoon crushed red pepper, optional**

Remove any visible gristle from meat. Cut turkey and pork into 1 - inch cubes. Place meats in a large bowl and add the remaining ingredients. Stir well to combine. Cover and refrigerate for at least 8 and up to 24 hours.

Assemble Waring Pro™ Meat Grinder with the medium cutting plate. Grind meat, mixing turkey and pork evenly while grinding. Ground sausage may be stuffed into prepared casings or formed into patties. Fresh sausage should be cooked within 24 hours or double wrapped and frozen. Cook thoroughly before serving - internal temperature should register 170° F when tested with an instant read thermometer.

Nutritional information per suggested serving:
Calories 225 (45% from fat) • carb. 0g • pro. 30g • fat 11g • sat. fat 4g chol. 94mg • sod. 173mg • calc. 14mg • fiber 0g

Spicy Venison Sausage

Adding some pork butt makes the sausage a little moister, you may use all venison if you wish.

Makes 4 pounds

- 3 pounds venison**
- 1 pound pork butt**
- 1 cloves garlic, peeled and minced**
- 1-1/2 tablespoons kosher salt**
- 1-1/2 tablespoons freshly ground pepper**
- 2 teaspoons sweet paprika**
- 1 teaspoon honey**
- 1 teaspoon cayenne pepper**
- 1/2 teaspoon rubbed sage**
- 1/2 teaspoon savory**

Remove any visible gristle from meat. Cut meats into 1 - inch cubes. Place meats in a large bowl and add the remaining ingredients. Stir well to combine. Cover and refrigerate for at least 8 and up to 24 hours.

Assemble Waring Pro™ Meat Grinder with the medium cutting plate. Grind meat, mixing venison and pork evenly while grinding. Ground sausage may be stuffed into prepared casings or formed into patties. Fresh sausage should be cooked within 24 hours or double wrapped and frozen. Cook thoroughly before serving - internal temperature should register 160° F when tested with an instant read thermometer. Venison sausage may also be smoked in a homestyle smoker. Use wood flavor of your choice, suggestions would include hickory or mesquite. Recommended smoking temperature is 175° - 200° F, and smoking time should be 4 to 6 hours. Cook or smoke sausage thoroughly before serving - internal temperature should register 160° F when tested with an instant read thermometer.

Nutritional information per suggested serving:

Calories 1170 (33% from fat) • carb. 1g • pro. 27g • fat 6g • sat. fat 2g chol. 97mg • sod. 431 • calc. 14mg • fiber 0g

Waring Consumer Products

150 Milford Road
East Windsor, NJ 08520

www.waringproducts.com

Printed in Taiwan

MG100 IB
02WA23109

IB# 4267