

WINGCO®

INDUSTRIAL GENERATORS

HP Series
TF Series

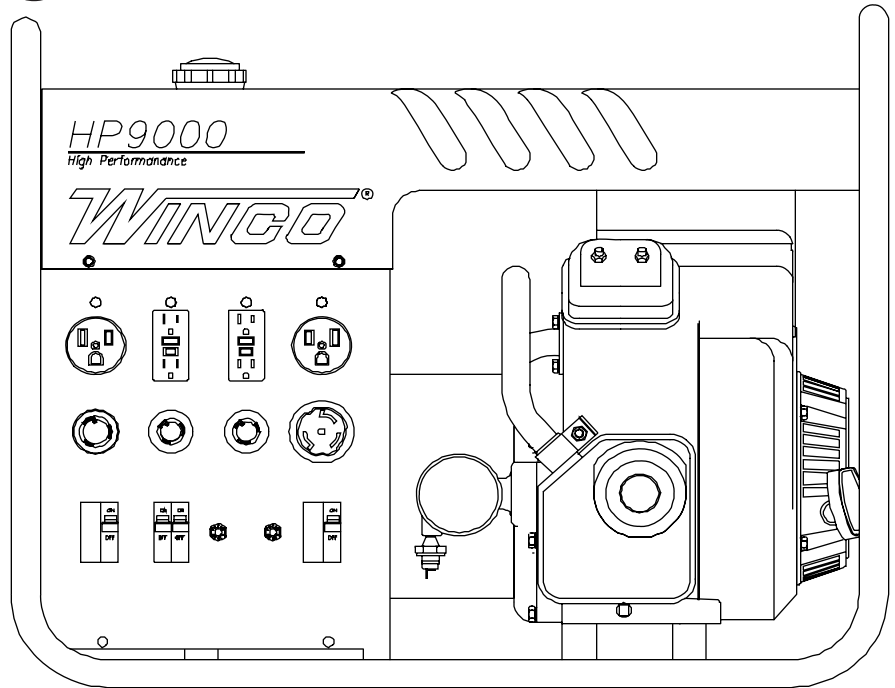

HP9000VE
Shown

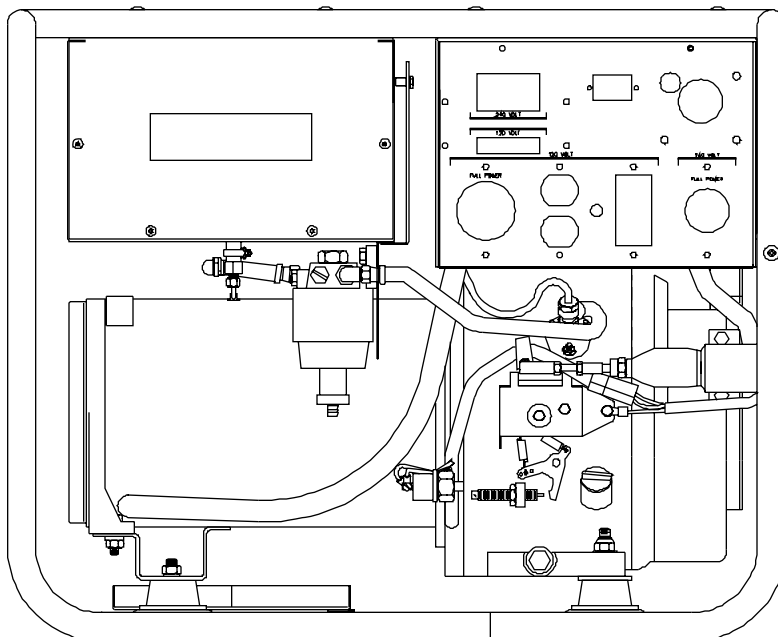

HD6010DEX
Shown

HD Series

OPERATORS MANUAL

60706-113

WINGCO®
INCORPORATED

Read and understand all instructions in the manual before starting and operating the generator set.

USING THIS MANUAL

Congratulations on your choice of a Winco generator set. You have selected a high-quality, precision-engineered generator set designed and tested to give you years of satisfactory portable service.

To get the best performance from your new engine generator set, it is important that you carefully read and follow the operating instructions in this manual.

Should you experience a problem please follow the "Things To Check" near the end of this manual. The warranty listed in this manual describes what you can expect from WINCO should you need service assistance in the future.

TABLE OF CONTENTS

INTRODUCTION	i	
FEATURES BY MODEL TABLE		1
GUIDE TO PRODUCT SAFETY		2
BASIC INFORMATION		
Intended Uses		3
Restricted Uses		3
Unit Capabilities	3	
PREPARING THE UNIT		4
Unpacking the unit		4
Unit Preparation	4	
LP/NG Installation		4
Battery Installation		6
Low Oil Shutdown		6
Automatic Idle		7
BASIC OPERATION		7
Starting		7
Starting Hints		8
Stopping And Storage	8	
Operating Speed	8	
Connecting The Load	9	
INSTALLATION GUIDELINES		9
Wiring		9
OPERATOR CARE AND MAINTENANCE	10	
Engine Care	10	
Generator Care		10
Cleaning		11
Things To Check BEFORE		
You Call For Service	11	
24 MONTH WARRANTY	13	

PROPER USE AND INSTALLATION

You must be sure your new engine generator set is:

- * Properly serviced before starting
- * Operated in a well ventilated area
- * Exhaust gases are dispersed safely
- * Wired by a qualified electrician
- * Operated only for its designed purposes
- * Used only by operators who understand its operation
- * Properly maintained

COPY YOUR MODEL AND SERIAL NUMBER HERE

No other WINCO generator has the same serial number as yours. It is important that you record the number and other vital information here, if you should ever need to contact us on this unit it will help us to respond to your needs faster.

MODEL _____

SERIAL NUMBER _____

PURCHASE DATE _____

DEALER _____

FEATURES BY MODEL

MODEL	ENGINE TYPE	FUEL TYPE	GENERATOR WARRANTY PERIOD*	FUEL TANK SIZE	ELECTRIC START	AUTOMATIC IDLE CONTROL	120 VOLT FULL POWER	4-WIRE TWISTLOCK RECP.T.	CSA AVAIL.
HD3200	KAWA.	GASOLINE	2 YEARS	3QT	NO	NO	YES	NO	YES
HD3200H	HONDA	GASOLINE	2 YEARS	4QT	NO	NO	YES	NO	YES
HD4500	B&S IC	GASOLINE	2 YEARS	6QT	NO	NO	YES	NO	YES
HD4500E	B&S IC	GASOLINE	2 YEARS	6QT	YES	NO	YES	NO	YES
HDM6000	B&S IC	GASOLINE	2 YEARS	6QT	NO	NO	YES	NO	YES
HDM6000E	B&S IC	GASOLINE	2 YEARS	6QT	YES	NO	YES	NO	YES
HD6010DEX	YANMAR	DIESEL	2 YEARS	4.5 GAL	YES	NO	YES	NO	NO
HD15000KE	KOHLER	GASOLINE	1 YEAR	12 GAL	YES	NO	NO	NO	NO
HP3300V	B&S VGD	GASOLINE	2 YEARS	3.5 GAL	NO	YES	YES	NO	NO
HP3300H	HONDA	GASOLINE	2 YEARS	3.5 GAL	NO	YES	YES	NO	YES
HP4500	B&S IC	GASOLINE	2 YEARS	4.5 GAL	NO	YES	YES	NO	YES
HP5000H	HONDA	GASOLINE	2 YEARS	4.5 GAL	NO	YES	YES	NO	YES
HPM6000	B&S IC	GASOLINE	2 YEARS	4.5 GAL	NO	YES	YES	NO	YES
HPM6000E	B&S IC	GASOLINE	2 YEARS	4.5 GAL	YES	YES	YES	NO	YES
HPM6000H	HONDA	GASOLINE	2 YEARS	4.5 GAL	NO	YES	YES	NO	YES
HPM6000HE	HONDA	GASOLINE	2 YEARS	4.5 GAL	YES	YES	YES	NO	YES
HP9000VE	B&S VGD	GASOLINE	2 YEARS	4.5 GAL	YES	YES	45.8 AMPS	YES	YES
HP9500HE	HONDA	GASOLINE	2 YEARS	4.5 GAL	YES	YES	45.8 AMPS	YES	NO
TF4500E	B&S IC	GASLPING	2 YEARS	4.5 GAL	YES	NO	YES	YES	YES
TFM6000E	B&S IC	GASLPING	2 YEARS	4.5 GAL	YES	NO	YES	YES	YES
TF9000VE	B&S VGD	GASLPING	2 YEARS	4.5 GAL	YES	NO	45.8 AMPS	YES	YES

* See engine manual for specific engine warranty period.

Page 12

Page 7

Page 7

Page 3

GUIDE TO PRODUCT SAFETY

This engine generator set has been designed and manufactured to allow safe, reliable performance. Poor maintenance, improper or careless use can result in potential deadly hazards; from electrical shock, exhaust gas asphyxiation, or fire. Please read all safety instructions carefully before installation or use. Keep these instructions handy for future reference. Take special note and follow all warnings on the unit labels and in the manuals.

ANSI SAFETY DEFINITIONS

DANGER:

DANGER indicates an imminently hazardous situation which, if not avoided, will result in death or serious injury. This signal word is to be limited to the most extreme situations.

WARNING:

WARNING indicates a potentially hazardous situation which, if not avoided, could result in death or serious injury.

CAUTION:

CAUTION indicates a potentially hazardous situation which, if not avoided, may result in minor or moderate injury. It may also be used to alert against unsafe practices.

NOTE:

CAUTION is also used on the unit labels and in this manual to indicate a situation that could result in serious damage or destruction of the equipment and possible personal injury.

1. **ELECTRIC SHOCK-** The output voltage present in this equipment can cause a fatal electric shock. This equipment must be operated by a responsible person.
 - a. Do not allow anyone to operate the generator without proper instruction.
 - b. Guard against electric shock.
 - c. Avoid contact with live terminals or receptacles.
 - d. Use extreme care if operating this unit in rain or snow.
 - e. Use only three-prong grounded plugs and extension cords.
 - f. Be sure the unit is properly grounded to an external ground rod driven into the earth.
2. **FIRE HAZARD-** Gasoline and other fuels always present a hazard of possible explosion and/or fire.
 - a. Do not refuel when the engine is running or hot. Allow the engine to cool at least two minutes before refueling.
 - b. Keep fuel containers out of reach of children.
 - c. Do not smoke or use open flame near the generator set or fuel tank.
 - d. Keep a fire extinguisher nearby and know its proper use. Fire extinguishers rated ABC by NFPA are appropriate.
 - e. Store fuel only in an approved container, and only in a well-ventilated area.

3. **DEADLY EXHAUST GAS-** Exhaust fumes from any gasoline engine contain carbon monoxide, an invisible, odorless and deadly gas that must be mixed with fresh air.
 - a. Operate only in well ventilated areas.
 - b. Never operate indoors.
 - c. Never operate the unit in such a way as to allow exhaust gases to seep back into closed rooms (i.e. through windows, walls or floors).
4. **NOISE HAZARD -** Excessive noise is not only tiring, but continual exposure can lead to loss of hearing.
 - a. Use hearing protection equipment when working around this equipment for long periods of time.
 - b. Keep your neighbors in mind when permanently installing this equipment.
5. **CLEANLINESS-** Keep the generator and surrounding area clean.
 - a. Remove all grease, ice, snow or materials that create slippery conditions around the unit.
 - b. Remove any rags or other material that could create potential fire hazards.
 - c. Carefully wipe up any gas or oil spills before starting the unit.
 - d. Never allow leaves or other flammable material to build up around the engine exhaust area.
6. **SERVICING EQUIPMENT-** All service, including the installation or replacement of service parts, should be performed only by a qualified technician.
 - a. Use only factory approved repair parts.
 - b. Do not work on this equipment when fatigued.
 - c. Never remove the protective guards, cover, or receptacle panels while the engine is running.
 - d. Use extreme caution when working on electrical components. High output voltages from this equipment can cause serious injury or death.
 - e. Always avoid hot mufflers, exhaust manifolds, and engine parts. They all can cause severe burns instantly.
 - f. Installing a home-standby generator is not a "do-it-yourself" project. Consult a qualified, licensed electrician or contractor. The installation must comply with all national, state, and local codes.

INTENDED USES

These engine generator sets have been designed primarily for portable use. Both 120 and 240 volt AC receptacles are provided in the 'control panel' to plug in your loads (lights, portable tools, and small appliances). These units are dual wound generators, therefore the 120 Volt loads must be equally split with 1/2 of the rated capacity available on each of the two 120 Volt circuits. See unit capabilities for further explanation.

BASIC INFORMATION

These portable units require large quantities of fresh air for cooling of both the engine and the generator. Fresh air is drawn from both the engine end and the generator end and is exhausted at the center of the unit. For safety, long life and adequate performance, these units should never be run in small compartments without positive fresh air flow.

RESTRICTED USES

DO NOT remove from the cradle assembly. Removal of the generator from the cradle assembly may cause excessive vibration and damage to the engine generator set.

DO NOT install and operate these portable generators in a small compartment., i.e. generator compartment of vehicles, motor homes or travel trailers. These compartments will not allow enough free flow fresh air to reach the engine generator set for cooling and will cause the unit to overheat, damaging both the engine and the generator. Small compartments will also develop hot spots where there is very little air flow and may cause a fire.

DO NOT attempt to operate at 50 cycles. These units are designed and governed to operate at 60 Cycles only.

UNIT CAPABILITIES

Generator Connections

The diagram below represents a typical 4000 watt generator. Receptacles A and B are the two 120 Volt duplex receptacles. Up to 2000 watts at 120 volts (16.6 Amps) can be taken from the generator at each of the receptacles. This generator produces 120 and 240 volt, 60 Hz (Hertz), AC (Alternating Current).

The WINCO High Performance series generators have the EXTRA Heavy FULL POWER winding to allow the use of all the power available from the engine at either 120 Volts, 240 Volts or any combination of the 120 or 240 volts. You are not restricted to splitting up your large 120 Volt loads or choosing to power them OR a 240 Volt load. There are no switches or connectors to change. Simply plug in and use the power without being concerned about overloading the generator winding as long as the load doesn't exceed the size of the generator.

Check the appliance or tool nameplates for the current and voltage to insure compatibility. Remember that power taken from receptacle C reduces the power available at both A and B and vice versa.

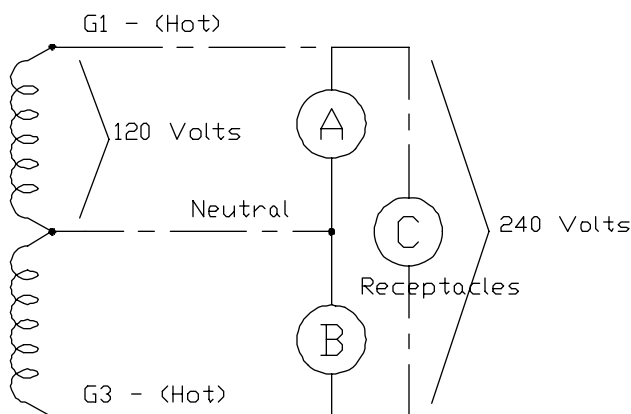

Starting Electric Motors

Electric motors require much more current (amps) to start them than to run them. Some motors, particularly low cost split-phase motors, are very hard to start and require 5 to 7 times as much current to start them as to run them. Capacitor motors are easier to start and usually require 2 to 4 times as much current to start them as to run them. Repulsion Induction motors are the easiest to start and usually require 1 1/2 to 2 1/2 times as much to start them as to run them.

Most fractional horsepower motors take about the same amount of current to run them whether they are of Repulsion-Induction (RI), Capacitor (Cap), or Split-Phase (SP) type. The chart below shows the approximate current required to start and run various types and sizes of 120 volt 60 cycle electric motors under average load conditions.

RUNNING HP	AMPS	STARTING AMPS		
		SP	CAP	RI
1/6	3.2	16 TO 22	6 TO 13	5 TO 8
1/4	4.5	22 TO 32	9 TO 18	7 TO 12
1/3	5.2	26 TO 35	10 TO 21	8 TO 17
1/2	7.2	NOT MADE	14 TO 29	11 TO 18
1	13.0	NOT MADE	26 TO 52	20 TO 33

The figures given above are for an average load such as a blower or fan. If the electric motor is connected to a hard starting load such as an air compressor, it will require more starting current. If it is connected to a light load, or no load such as a power saw, it will require less starting current. The exact requirement will also vary with the brand or design of the motor.

Self-excited generators respond to severe overloading differently than the power line. When overloaded, the engine is not able to supply enough power to bring the electric motor up to operating speed. The generator responds with high initial starting current, but the engine speed drops sharply. The overload may stall the engine. If allowed to operate at very low speeds, the electric motor starting winding will burn out in a short time. The generator winding might also be damaged.

CAUTION: EQUIPMENT DAMAGE

RUNNING THE GENERATOR SET UNDER THESE CONDITIONS MAY RESULT IN DAMAGING THE GENERATOR STATOR AS WELL AS THE MOTOR WINDING.

Because the heavy surge of current required for starting motors is required for only an instant, the generator will not be damaged if it can bring the motor up to speed in a few seconds of time. If difficulty is experienced in starting motors, turn all other electrical loads off and if possible reduce the load on the electric motor.

UNPACKING

CAUTION: EQUIPMENT DAMAGE

THIS UNIT HAS BEEN SHIPPED WITHOUT OIL. Failure to maintain the engine oil at the proper level will result in serious engine damage.

When you unpack your new ENGINE GENERATOR be sure to remove all the information sheets and manuals from the carton.

PREPARING THE UNIT

1. This generator set was in good order when shipped. Inspect the power plant promptly after receiving it. If damage is noted, notify the transportation company immediately, request proper procedures for filing a "concealed damage" claim. Title to the equipment and responsibility for filing a claim rests with you when a generator is sent F.O.B. shipping point. Only you can legally file a claim.
2. Before proceeding with the preparation of your new engine generator set for operation, take a couple of minutes to insure that the unit you have received is the correct model and review the specification pages in this manual to insure that this unit fits your job requirements.
3. After removing the engine generator from the carton locate and remove the shipping strap attached to the generator shock mount. See attached tag for removal instructions.

UNIT PREPARATION

Before your engine generator was shipped from our factory it was fully checked for performance. The generator was load tested to its full capacity, and the voltage and frequency were carefully checked and adjusted.

LUBRICATION

Before starting the engine, fill the crankcase to the proper level with a good quality oil. The recommended grade of oil and quantity of oil required is listed in the engine operator's manual shipped with our unit. The necessity of using the correct oil, and keeping the crankcase full cannot be overemphasized. Engine failures resulting from inadequate or improper lubricant are considered abuse and are not covered by the generator or the engine manufacturer's warranty.

GASOLINE FUEL

Always use a good grade of unleaded fuel. Leaded gasoline may be used if unleaded is not available. Gasoline containing alcohol, such as gasohol is not recommended. However, if gasoline with alcohol is used, it must not contain more than 10 percent Ethanol and must be removed from the engine during storage. DO NOT use gasoline containing methanol. Always insure that the fuel is clean and free of all impurities.

DIESEL FUEL

ASTM No.2 diesel fuel is recommended for these engines. The use of No. 2 diesel fuel will result in optimum engine performance. The use of a lighter fuel will reduce fuel economy. See your engine operators manual for complete fuel information.

WARNING: FIRE DANGER

Gasoline, diesel fuel and its fumes are VERY explosive when proper precautions are not taken.

Never use fuel that has been stored for an extended period of time as the fuel will lose it's volatile properties and you will be left with only the varnish residue. This varnish like substance will clog the carburetor or injectors and will not

burn properly. The use of a fuel additive, such as STA-BIL, or an equivalent will minimize the formation of fuel gum deposits. If a unit has been out of operation for an extended period of time it is best to drain old fuel from the fuel tank and replace with fresh fuel before attempting to start.

LP/NG FUEL INSTALLATION

The information in this instruction is offered to assist you in providing the proper vapor fuel supply for your engine. This information is only provided to advise you of the engine's requirements and the decisions you must make. In no case should this information be interpreted to conflict with any local, state or national code. If in doubt, always follow local codes.

DANGER: FIRE - PERSONAL INJURY -

All fuel lines must be installed by qualified fuel supplier.

LOCATION

The engine-generator models covered in this manual were designed for portable use. **DO NOT INSTALL OR OPERATE THESE UNITS INDOORS.** The unit should be stored in a dry location. During a power outage move the unit outdoors to a flat dry location such as a driveway, concrete pad or sidewalk for use. We recommend installing the optional dolly kit or equivalent for ease of handling.

The fuel source should be as close as possible to the outdoor operating location. This will reduce the installation cost of fuel runs. Connect the fuel supply line to the inlet of the fuel demand regulator on the unit using a locally approved flexible fuel line (see table for recommended line size). The pressure supplied to the demand regulator **MUST BE FOUR TO SIX OUNCES or 7 to 11 INCHES W.C.(water column).** The primary regulator at the fuel supply must be capable of delivering the proper volume of fuel at this pressure.

Have your local fuel supplier install a protected fuel connection at the outside operating location. He should also install a lockable fuel shutoff valve at the connection point. Have your fuel supplier permanently install a flexible fuel line to the demand regulator on the engine generator set.

INSTALLING THE FUEL LINE

DANGER: PERSONAL INJURY

Units that are intended to be run unattended MUST have an electric fuel solenoid installed. This solenoid MUST be wired to AUTOMATICALLY turn off the fuel whenever the engine stops. Request instruction sheet 60714-009 from your dealer for additional information.

Unit location will determine the size of fuel line that is required to supply the engine with a constant fuel pressure. Refer to the tables below for fuel line size, and recommended tank size. For distances of 100 feet and over, a two regulator fuel system consisting of a primary 10-15# regulator at the tank and a 6 ounce secondary regulator installed close to the engine-generator set. When a two (2) stage regulator system is used, a fuel line size of 3/8 inch is generally adequate for distances up to 300 feet.

PREPARING THE UNIT

The line size from the table below applies to the distance from the second regulator to the demand regulator. A positive fuel shut-off device must be installed in the fuel line close to the engine generator set. This may be either a lockable manual shut-off valve available from your local fuel installer, or a 12 volt DC fuel solenoid valve. This optional 12 volt DC valve is available through your local Winco dealer as part number 42942-000.

The fuel line used to connect the supply line to the demand regulator must be a locally approved flexible fuel line. Products used will vary in different regions depending on availability and local codes. Consult with your local fuel supplier to insure complete compliance with ALL codes.

1. Remove the pipe plug from the demand regulator.
2. Connect the flex fuel line to the demand regulator.

DANGER: PERSONAL INJURY

Do not use galvanized pipe in the fuel line runs. The galvanized coating will become eroded and flake off, causing possible obstruction or damage to the regulator or fuel valve. The obstruction could cause an inoperative engine or an explosive fuel leak.

Size of pipe required for generators operating on natural gas/LP gas.

Length of Fuel Line	Fuel Line Size
Up to 25 Feet	3.4 inch Black Pipe
25 to 100 Feet	1 inch Black Pipe
Over 100 Feet	Not Recommended

*allow an additional 3 feet for each standard elbow. Do not use 'street ells' (restrictive)

DANGER! - FIRE - PERSONAL INJURY -

Be careful when sealing gas joints. Excessive sealing compound can be drawn into the solenoid, regulator or carburetor causing an engine malfunction or dangerous fuel leak.

FUEL PRESSURE

Correct fuel pressure cannot be stressed enough. The most common cause for inoperative systems is an inadequate or incorrect fuel pressure. Power and performance of the engine is in direct relation to the correctness of the fuel system. Shown below is a block diagram of a typical L.P. or N.G. installation.

Single Regulator Fuel System

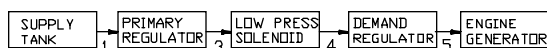

Two Regulator Fuel System

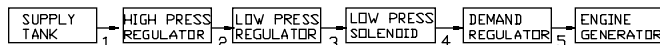

Reference numbers 1 through 4 in the block diagrams above are fuel lines supplied by customer.

Reference number 5 is already installed on your engine generator set.

Remember that whichever fuel delivery system or type of vapor fuel used, the fuel pressure at the demand regulator installed on the engine generator must be between 4 and 6 oz (7-11 inches of water column). Any lower pressure and the unit will starve for fuel under load. Any higher and the unit will 'flood' when attempting to start.

LP TANK SIZING

Once above the minimum acceptable size, the size of L.P. tank used will generally depend on how long you want the unit to run without re-filling. The tank sizes shown below are the smallest recommended tank sizes based on the outside temperature. Keep in mind the colder it gets the slower L.P. will vaporize. This is the reason for the larger tanks at low temperature. Minimum sizing is not based on running time.

Temp	60 deg F.	30 deg F.	0 deg F.	-20 deg F.
TF4500	30 gal	40 gal	100 gal	200 gal
TFM6000	40 gal	50 gal	125 gal	350 gal
TF9000	70 gal	80 gal	200 gal	700 gal

CHANGING FUEL TYPES

These engine generator sets are designed to run on three different fuels; gasoline, natural gas or LP vapor. They may be easily changed from one fuel to another.

FROM GASOLINE TO LP/NG

1. With the engine running turn off the gasoline fuel valve.
2. Run the engine until it runs out of fuel.
3. Remove the pipe plug from the demand regulator.
4. Install locally approved flexible fuel line.
5. Connect the LP/NG vapor fuel line.
6. Turn on the vapor fuel.
7. Start the engine.
8. Apply the load to the generator.
9. Adjust the fuel mixture valve to smooth the engine out.

Note: *Operating on LP/NG vapor fuel for an extended period of time without liquid fuel in the carburetor may damage the carburetor float, and the needle seat assembly. If you plan to convert back to gasoline, we recommend the float and needle seat assembly be removed from the carburetor. (Consult a local engine supplier for assistance.)*

FROM LP/NG TO GASOLINE

1. With the engine running turn off the LP/NG fuel supply.
2. Run the engine until it runs out of fuel.
3. Remove the flexible fuel line from the demand regulator.
4. Reinstall the pipe plug in the regulator. (use thread sealant sparingly)
5. Check to be sure the gasoline fuel valve is off.
6. Fill the gasoline fuel tank.
7. Turn on the gasoline fuel valve.
8. Start the engine.
9. Adjust the load jet on the carburetor as required to smooth the engine out.

PREPARING THE UNIT

BATTERY INSTALLATION

All electric start engine generator sets are shipped with a battery kit for customer installation. This kit consists of a battery rack, battery tie down, battery cables, and instruction sheet for installation. After installing the battery rack, file the instruction sheet in the back of this manual for future reference.

If you intend to use the power plant's electric start system, you will need to purchase and install a battery to operate it. Units equipped with a recoil or rope start will operate satisfactorily without a battery. A twelve volt battery, group U1 rated at 235 CCA or larger is recommended for this electric start engine generator set. Follow the battery manufacturers recommendations for servicing and charging prior to use. Connect the battery to the electric start system using the cables provided.

CAUTION: EQUIPMENT DAMAGE

These electric start engines are NEGATIVE GROUND. Use extreme caution when connecting the battery. Connect the NEGATIVE battery terminal to GROUND.

For your safety always connect the positive battery cable to the "bat+" terminal first. Then connect the negative battery cable to the "bat-" terminal. Make sure all connections are clean and tight. Reverse the sequence when disconnecting, disconnect the negative cable first. These engines produce enough direct current to keep a battery charged under normal operating conditions, but were not intended to be used as a battery charger.

WARNING: PERSONAL INJURY

Lead acid batteries produce explosive hydrogen gas when charging. Keep sparks, flames, and burning cigarettes away from the battery. Ventilate the area when charging or using the battery in an enclosed space. Lead acid batteries contain sulfuric acid, which causes severe burns. If acid contacts eyes, skin or clothing, flush well with water. For contact with eyes, get immediate medical attention

Battery Charging

Units equipped with electric start have a small flywheel charger built into the engine flywheel assembly for recharging the starting battery. This flywheel charger generates a small AC current that passes through a diode at the end of the charging lead to produce a DC charging current of about 1 AMP. This circuit is not designed to be used as a battery charging circuit to recharge dead batteries.

OPTIONAL DOLLY KIT

An optional dolly kit is available for most of these engine generator sets. The dolly kit comes with instructions and parts list. After installing the dolly kit, file the instructions and parts list in the back of this manual for future reference.

LOW OIL LEVEL SHUTDOWN SYSTEM

All Winco Industrial generators are equipped standard with low oil shutdown systems. The Honda, Kawasaki and Briggs & Stratton IC engines all use a float switch system. This low oil warning system will automatically stop the engine before the oil level reaches an operational danger point. This

feature is designed to prevent costly repairs and downtime.

This system uses a float in the engine crankcase to sense the oil level. If a low oil level condition should occur during operation, the float will ground out the magneto impulse, "killing" the engine. In addition, there is an indicator light mounted on the engine shroud near the recoil starter. This light will blink on and off to indicate a low oil level condition when you are attempting to start the unit. To get the engine started, you must add the required amount of oil to the engine crankcase.

Use of the float system on applications that are subject to shock, bumping or severe angles of operation (in excess of 15 degrees) should be avoided. This is especially true if an unexpected **shutdown would cause a safety hazard** or serious inconvenience for the operator. To disable the OILGARD, remove the wire attached to the sensor unit mounted on the engine crankcase. The wire should be insulated with a connector or tape.

The Yanmar diesel, Kohler Commander and the Briggs & Stratton Vanguard all use a pressurized oil system. The oil pressure is monitored by an oil pressure sensor mounted on the engine. If the oil pressure gets low during operation the engine ignition is grounded out and the engine will shutdown. On the Yanmar the oil pressure sensor opens the power feed to the run solenoid, allowing the fuel rack to close shutting the engine down. If during starting the oil system doesn't build sufficient pressure to close the oil sensor switch the engine will not continue to run. This can be caused by a low oil level or by using the wrong grade of oil for the ambient air temperature.

AUTOMATIC IDLE CONTROL (HP Series Only)

The automatic idle control is a gas saving, solid state system, designed to reduce engine speed whenever the electrical load is removed from the generator. Without a slow down control, the engine would run at full speed at all times, regardless of the electrical load. With the automatic idle control switch in the 'Auto' position, the throttle control lever is electrically released when the load is turned on so it in no way interferes with the normal governor operation. When the load is turned off, the idle magnet energizes and reduces the engine speed. It does not cause incorrect operation of the carburetor or governor, but neither does it correct them.

The automatic idle control consists of a solid state module mounted in the generator end cover, a switch, resistor and transformer located in the generator control box, and an electromagnet mounted on the engine near the throttle lever. The automatic idle control is only offered as a factory installed feature. It is not available for field installation.

With the automatic idle switch in the "automatic" position, the system operates as follows:

1. After the engine has been started, and no electrical load is applied, the transformer senses and signals the solid state module to turn **ON** the electromagnet. This will pull and hold the throttle lever, closing the throttle on the carburetor reducing the engine speed.
2. When a load is applied to the generator, the transformer senses it and sends a signal to the solid state module to turn off the electromagnet. This allows

BASIC OPERATION

the throttle to release and allows the governor spring to open the throttle. The engine will respond and come up to the governed speed (3600 rpm).

3. When the electrical load is turned off, no power will flow through the transformer, and as a result, the automatic idle control will once again energize the magnet, pulling and holding the throttle.

When the automatic idle switch is in the "off" position, the engine will run at full governed speed regardless of the generator load.

INITIAL START UP

Use the following checklist to verify the correct preparation of the engine generator before starting.

Before Starting always Check:

1. Engine oil, fill as required with correct grade and quantity.
2. Fuel level, fill as required with clean fresh fuel.
3. Automatic Idle is in the 'Off' position
4. Visually check for loose or broken parts.

STARTING

The throttle control on these generators is preset and locked to operate at 3600 RPM (nominal) with no load speed set at 3690 RPM. Only a trained service technician should be allowed to adjust this speed setting. See "Operating Speed" section for additional information.

NOTICE: ENGINE

These units **will not start** if it is low on oil. The lubricating oil level must be at the **full** mark before the engine will start.

MANUAL STARTING

Refer to the engine manual for additional starting, operating, and stopping instructions.

NOTICE: TRI-FUEL STARTING

Tri-Fuel generators operating on vapor fuel, (either L.P. or NG) must be started using the electric start system provided. You cannot hand crank the unit fast enough to develop the proper vacuum to make the vapor fuel system work. In addition when starting on **VAPOR FUEL NEVER USE THE CHOKE**. Use of the choke will prevent the air and fuel from properly mixing.

1. Turn on the fuel supply.
2. For **gasoline** move the choke to the full "on" position. A warm engine will require less choking than a cold engine.
3. Grasp starter grip and pull slowly until starter engages, then pull cord rapidly to overcome compression, prevent kickback and start the engine. Repeat if necessary.
4. When the engine starts, open the choke gradually.
5. The engine should promptly come up to operating speed.

ELECTRIC STARTING

If the engine is cold and stiff or if the battery is not fully charged, starting can be made easier by slowly hand cranking the engine through the compression stroke before pushing the starter switch. This permits the starter to gain momentum before the heavy load of the compression stroke

occurs. This minimizes the drain on the battery and improves the possibility of starting under such adverse conditions. Always keep the battery charged, especially during cold weather operation.

1. Turn on the fuel supply.
2. For **gasoline** move the choke to the full "on" position. A warm engine will require less choking than a cold engine.
3. Engage the engine start switch briefly to the START position. The starter life is improved by using shorter starting cycles with time to cool off between cranking cycles. Do not operate the starter more than 15 seconds during each minute. Repeat if necessary.
4. When the engine starts, open the choke gradually.
5. The engine should promptly come up to operating speed.

CAUTION: EQUIPMENT DAMAGE

Never permit the choke to remain on after the engine has run for a short time. It is not necessary to choke the engine when it is warm. Avoid over-choking.

STARTING HINTS

1. Cold weather
 - a. Use the proper oil for the temperature expected.
 - b. Use fresh winter grade fuel. Winter grade gasoline is blended to improve starting. Do not use summer gasoline.
 - c. A slightly richer fuel mixture will usually improve cold starting.
2. Hot weather
 - a. Use the proper oil for the temperature expected.
 - b. Use only summer blended gasoline. Using gasoline left over from winter may cause the unit to vapor lock.
 - c. DO NOT over-choke the unit.

STOPPING AND STORAGE

1. Depress the stop switch.
2. Close the fuel shut-off valve. Always shut the fuel off whenever the engine is stopped to prevent fuel leakage from carburetor.
3. Before extended storage (over 30 days) certain precautions must be taken to ensure the fuel doesn't deteriorate and clog the fuel system.
 - a. Remove the remaining fuel from the fuel tank.
 - b. Start the engine and allow it to run until all the fuel in the carburetor and the fuel lines has been used up and the engine stops.
 - c. While the engine is warm, drain the oil and refill with fresh oil.
 - d. Remove the spark plug, pour approximately 1/2 ounce (15 cc) of engine oil into the cylinder and crank slowly to distribute oil. Replace spark plug.
 - e. Clean dirt and chaff from cylinder, cylinder head fins, blower housing, rotating

BASIC OPERATION

- screen and muffler areas.
f. Store in a clean and dry area.

Note: The use of a fuel additive, such as STA-BIL, or an equivalent, will minimize the formation of gum deposits during storage. Such an additive may be added to gasoline in the engine's fuel tank or to gasoline in a storage container.

OPERATING SPEED

The engine-generator must be run at the correct speed in order to produce the proper electrical voltage and frequency.

CAUTION: EQUIPMENT DAMAGE

The output voltage should be checked to insure the generator is working properly prior to connecting a load to the generator. Failure to do so could result in damage to equipment plugged into the unit and possible injury to the individual.

All engines have a tendency to slow down when a load is applied. When the electrical load is connected to the generator, the engine is more heavily loaded, and as a result the speed drops slightly. This slight decrease in speed, together with the voltage drop within the generator itself, results in a slightly lower voltage when the generator is loaded to its full capacity than when running no load. The slight variation in speed also affects the frequency of the output current. This frequency variation has no appreciable effect in the operation of motors, lights and most appliances. However, electronic equipment and clocks will be affected if correct RPM is not maintained. See Load vs. Output chart.

Although individual units and models may vary slightly, the normal voltage and frequency of the engine-generators described in this book are approximately as follows, under varying loads:

LOAD vs. OUTPUT

Generator Load Applied*	Frequency Speed (RPM)		Generator voltage (Hz) Recpt. 120V	
	None	3690	61.5	
Half	3600	60.0	120V	
Full	3510	58.5	115V	

*Portion of plant's rated output current.

The speed of the engine was carefully adjusted at the factory so that the generator produces the proper voltage and frequency. For normal usage, the speed setting should not be changed. If the generator is being run continuously on a very light load, it is often advisable to lower the operating speed slightly. Whenever making any speed adjustments check the unit with a voltmeter or tachometer and be sure the speed is correct.

Lower voltage may damage both the generator and any load connected to it. Running the engine at excessively high speeds results in high voltage, which may significantly shorten the life of appliances being used.

Output voltage should be checked periodically to ensure continued proper operation of the generating plant and appliances. If the generator is not equipped with a voltmeter, it can be checked with a portable meter. Frequency can be checked by using an electric clock with a sweep second hand. Timed against a wrist watch or a stop watch the clock

should be correct within +/- 2 seconds per minute.

CONNECTING THE LOADS

Applying The Load

Allow the engine to warm up for two or three minutes before applying any load. This will allow the engine to reach normal operating temperature and oil to circulate throughout the engine. A short warm-up time will permit the engine to work more efficiently when the load is applied and will reduce the wear in the engine, extending its life.

Receptacles have been provided to allow loads to be connected to the generator. The loads should be added one at a time. If a large motor is being started or multiple motors are being started, they should be started individually and the largest should be started first.

CAUTION: EQUIPMENT OVERLOAD

Keep the generator load within the generator and receptacle nameplate rating. Overloading may cause damage to the generator and/or the loads .

Most electric tools and appliances will have the voltage and amperage requirements on their individual nameplates. When in doubt consult the manufacturer or a local electrician. The nameplate amperage rating for electric motors can be misleading. See "Starting Electric Motors" in Unit Capabilities (page 3).

These engine generator sets are inherently self regulating based on engine speed. The engine governor will automatically adjust itself to the load. No harm to the generator will result if it is operated with no load connected.

Proper utilization of the receptacles located on the control panel is necessary to prevent damage to either the receptacles or the generator. The generator is a limited source of electrical power, therefore pay special attention to the receptacle and generator ratings. The nameplate rating can be obtained through a single receptacle as long as the receptacle amperage rating is not exceeded.

Grounding

All units must be grounded. Drive a 3/4 or 1" copper pipe or rod into the ground close to the engine-generator set. The pipe must penetrate moist earth. Connect an approved ground clamp, to the pipe. Run a no. 10 Awg wire from clamp to the generator ground lug on the "receptacle panel". Do not connect to a water pipe or to a ground used by a radio system.

The engine-generators covered in this manual were designed for portable use. **DO NOT OPERATE INDOORS.** The unit should be stored in a warm dry location. **Move the unit outdoors** to a flat dry location for use.

WIRING

Plug your tools such as drills, saws, blowers, sump pump and other items to be powered directly into the generator receptacles. Before plugging in all the tools and cord sets, recheck the rating of the generator set. Be sure it can handle the intended load and is compatible with the voltage, phase, and current ratings.

BASIC OPERATION

'Hard Wiring' this unit directly into a temporary construction site electrical system is NOT A SIMPLE DO-IT-YOURSELF JOB. For your safety all wiring must be done by a qualified electrician and conform to the National Electric Code and comply with all state and local codes and regulations. Check with local authorities before proceeding.

WARNING: PERSONAL DANGER

A fully isolated, double pole double throw manual transfer switch must be installed any time a generator is being connected to an existing distribution system.

1. These engine generator sets are designed for portable heavy duty commercial use. Receptacles are provided on the control panel to permit 120 and 240 volt portable appliances and tools to be plugged directly into them. Please note that the 3 wire 240 volt receptacle(s) on these units are designed to power only 240 volt tools. There are 2 hot and a ground wire, but no neutral connection in the 3 wire 240 volt receptacle. Split 120/240 volt 'TemPower' service requires the installation of a 4 wire receptacle (2 hot, 1 ground, and 1 neutral). Consult a licensed electrician for wiring the TemPower plug and connecting it as temporary service.

To connect these units directly to an un-powered, isolated construction site TemPower panel, have your electrician select one of the following methods:

- a. Wire the distribution panel directly to the generator output using a fine strand (flexible) motor lead wire. DO NOT by-pass the generator control panel mainline circuit breakers.
 - b. Wire a 120/240 volt, four wire twist-lock receptacle. (Hubbel Spec. #CS 6365) The use of locking receptacles and locking plugs provides the convenience of quickly disconnecting the wiring for moving the unit and security on the job site. The plug also allows non electrical workers to safely reconnect the power after moving the unit and prevents the plug from being accidentally removed by bumping or vibration.
2. If the generator set is connected to existing (electrical) wiring circuits (NOT RECOMMENDED with the HP series), it is permitted only through a fully isolated manual transfer switch. The transfer switch prevents damage to the generator and other circuit components if main line power is restored while the generator is connected. Installing a transfer switch also permits the use of normal fusing.
 3. Many homes and construction sites are wired for at least 60 to 100 Amp entrance service, much greater than the capacity of these portable generators. When installing the generator at these sites, a secondary emergency distribution panel may have to be installed, such as the Emergency Transfer/Service (ET/S) system available through your Winco dealer. The emergency distribution panel must be installed by a licensed electrician according to all applicable codes. The electrician will move the critical circuits to be powered

during the outage to the emergency panel. Keep in mind only a limited amount of amperage is available from the generator set. Some circuit breakers may still have to be turned off to prevent an overload on the generator during the initial start up. See the nameplate on your generator for the amperage capabilities of your unit.

CAUTION: EQUIPMENT DAMAGE

Failure to properly limit and balance the load applied to the generator will cause the generator to produce low voltage and may damage the engine generator set. It may also cause severe damage to the loads connected to the generator at that time. Improper loading of the generator set constitutes abuse and will not be covered by warranty.

ENGINE CARE

If major engine service or repair is required contact an authorized engine service center. The manufacturer of these engines has established an excellent world-wide engine service organization. Engine service is very likely available from a nearby authorized dealer or distributor. Check the yellow pages of your local telephone directory under "Engines-Gasoline" for the closest engine repair center or ask the dealer from whom you purchased the power plant.

Change the oil

After the first five hours of operation and every 25 hours (50 hours for engines with oil filters) thereafter under normal operating conditions. Change engine oil more often if the engine is operated under heavy load, or in high ambient temperatures.

- a. Remove oil drain plug at base of the engine and drain the oil with the engine warm.
- b. Replace oil drain plug.
- c. Change the oil filter if applicable
- d. Remove oil filler plug and refill with new oil.

Refer to the table in the engine manual for the proper grade of oil based on your operating temperature.

- e. Replace filler plug.

Checking the Oil Level

The oil level must always be checked before the engine is started. Take care to remove any dirt or debris from around the oil fill plug before removing. Be sure the oil level is maintained. FILL TO POINT OF OVERFLOWING or on units with the extended oil fill to the "FULL" mark on the dipstick.

Cartridge Air Cleaner

Remove and clean cartridge yearly or after every 25 hours, whichever occurs first. Service more often if necessary. Clean by tapping gently on flat surface. If very dirty, replace the cartridge using only original equipment parts available at any engine service center.

Do not use petroleum solvents, such as kerosene, to attempt to clean the cartridge. They may cause deterioration of the cartridge. **DO NOT OIL CARTRIDGE, DO NOT USE PRESSURIZED AIR TO CLEAN OR DRY CARTRIDGE.**

Dual Element Air Cleaner

Clean and re-oil foam pre-cleaner at three month intervals or every 25 hours, whichever occurs first. Service more often

OPERATOR CARE AND MAINTENANCE

under dusty conditions.

- a. Remove knob and cover.
- b. Remove foam pre-cleaner by sliding it off the paper cartridge.
- c. Wash foam pre-cleaner in kerosene or liquid detergent and water
- d. Wrap foam pre-cleaner in cloth and squeeze dry.
- e. Saturate foam pre-cleaner in engine oil. Squeeze to remove excess oil.
- f. Install foam pre-cleaner over paper cartridge. Reassemble cover and screw down tight.

Replace the cartridge included with Dual Element Air Cleaner yearly or every 100 hours. Service more often if necessary.

Spark Plug

Clean and reset gap at .030" every 100 hours of operation. Do not blast clean spark plug. Clean by scraping or wire brushing and washing with a commercial solvent. Poor spark will occur if terminal does not fit firmly on spark plug. If this happens reform the terminal to fit firmly on spark plug tip.

GENERATOR CARE

Proper care and maintenance of the generator is necessary to insure a long trouble free life.

Exercising The Generator

The generator should be operated every three to four weeks. It should be operated for a period of time sufficient to warm the unit up and to dry out any moisture that has accumulated in the windings (15 to 20 minutes). If left, this moisture can cause corrosion in the winding. Frequent operation of the engine generator set will also insure that the set is operating properly should it be needed in an emergency.

Generator Maintenance

Any major generator service including the installation or replacement of parts should be performed only by a qualified electrical service technician. **USE ONLY FACTORY APPROVED REPLACEMENT PARTS.**

- a. Bearing - The bearing used in these generators is a heavy duty double sealed ball bearing. They require no maintenance or lubrication.
- b. Receptacles - Quality receptacles have been utilized. If a receptacle should become cracked or otherwise damaged, replace it. Using damaged or cracked receptacles can be both dangerous to the operator and destructive to the equipment.

CLEANING

Remove dirt and debris with a cloth or brush. DO NOT use high pressure spray to clean either the engine or the generator. This high pressure spray could contaminate the fuel system and the generator components.

1. Keep the air inlet screen on both the engine and generator free of any dirt or debris to insure proper cooling. At least yearly remove the blower housing on the engine and clean the chaff and dirt out of the engine cooling fins and flywheel. Clean more often if necessary. Failure to keep these areas clean may cause overheating and permanent damage to the unit.
2. Periodically clean muffler area to remove all grass,

dirt and combustible debris to prevent a fire.

3. On engine mufflers equipped with spark arresters, the spark arrester must be removed every 50 hours for cleaning and inspection. Replace if damaged.

TROUBLESHOOTING HINTS

PROBLEM(SYMPTOMS) POSSIBLE CAUSES

Won't Start	<ul style="list-style-type: none"> *Low Oil Level. *Fouled spark plug. *Out of fuel. *Stop switch in stop position. *Engine won't turn over. *Fuel supply turned off. *Plugged air cleaner
Voltage too low	<ul style="list-style-type: none"> *Engine speed is too low. *Generator overloaded. *Defective rectifier. *Defective stator. *Defective rotor (field).
Voltage too high	<ul style="list-style-type: none"> *Engine speed is too high.
Circuit Breaker Trips	<ul style="list-style-type: none"> *Defective load. *Defective receptacle. *Overloaded circuit breaker
Generator overheating	<ul style="list-style-type: none"> *Overloaded. *Insufficient ventilation.
No output voltage	<ul style="list-style-type: none"> *Short in load (disconnect). *Broken or loose wire. *Defective receptacle. *No residual magnetism (in generator). *Defective stator. *Defective rotor (field). *Shorted capacitor. *Defective rectifier. *Circuit breaker tripped *Engine RPM below 3600 RPM

WINCO, Inc.

Limited Warranty

WINCO, Incorporated warrants to the original purchaser for the warranty period that goods manufactured or supplied by it will be free from defects in workmanship and material, provided such goods are installed, operated and maintained in accordance with **Winco** written instructions.

WINCO's sole liability, and Purchaser's sole remedy for a failure under this warranty, shall be limited to the repair of the product. At **WINCO's** option, material found to be defective in material or workmanship under normal use and service will be repaired or replaced. For warranty service, return the product within the warranty period from the date of purchase, transportation charges prepaid, to your nearest **WINCO** Authorized Service Center or to **WINCO, Inc.** at Le Center Minnesota.

THERE IS NO OTHER EXPRESS WARRANTY.

To the extent permitted by law, any and all warranties, including those of merchantability and fitness for a particular purpose, are limited to the warranty period from date of purchase. In no event is **WINCO** liable for incidental or consequential damages.

Note: Some states do not allow limitation on the duration of implied warranty and some states do not allow the exclusion or limitation of incidental or consequential damages, so the above limitations may not apply in every instance. This warranty gives you specific legal rights which may vary from state to state.

WINCO reserves the right to change or improve its products without incurring any obligations to make such changes or improvement on products purchased previously.

EXCLUSIONS:

WINCO does not warrant engines, batteries, receptacles, or other component parts that are warranted by their respective manufacturers.

WINCO does not warrant modifications or alterations which were not made by **WINCO, Inc.**

WINCO does not warrant products which have been subjected to misuse and/or negligence or have been involved in an accident.

This warranty does not include travel time, mileage, or labor for removal or reinstallation of **WINCO** product from its application.

WINCO®

I N C O R P O R A T E D

225 S. Cordova Ave.

Le Center MN 56057

612-357-6831

P/N 60706-113

WINCO®

INCORPORATED

225 South Cordova Avenue
Le Center MN 56057
612-357-6831