

WKM Pow-R-Seal Gate Valves

High-quality, through-conduit, expanding gate valves engineered for performance in critical isolation applications where a tight mechanical seal that is normally unaffected by pressure variations and vibrations is needed.

TECHNOLOGY



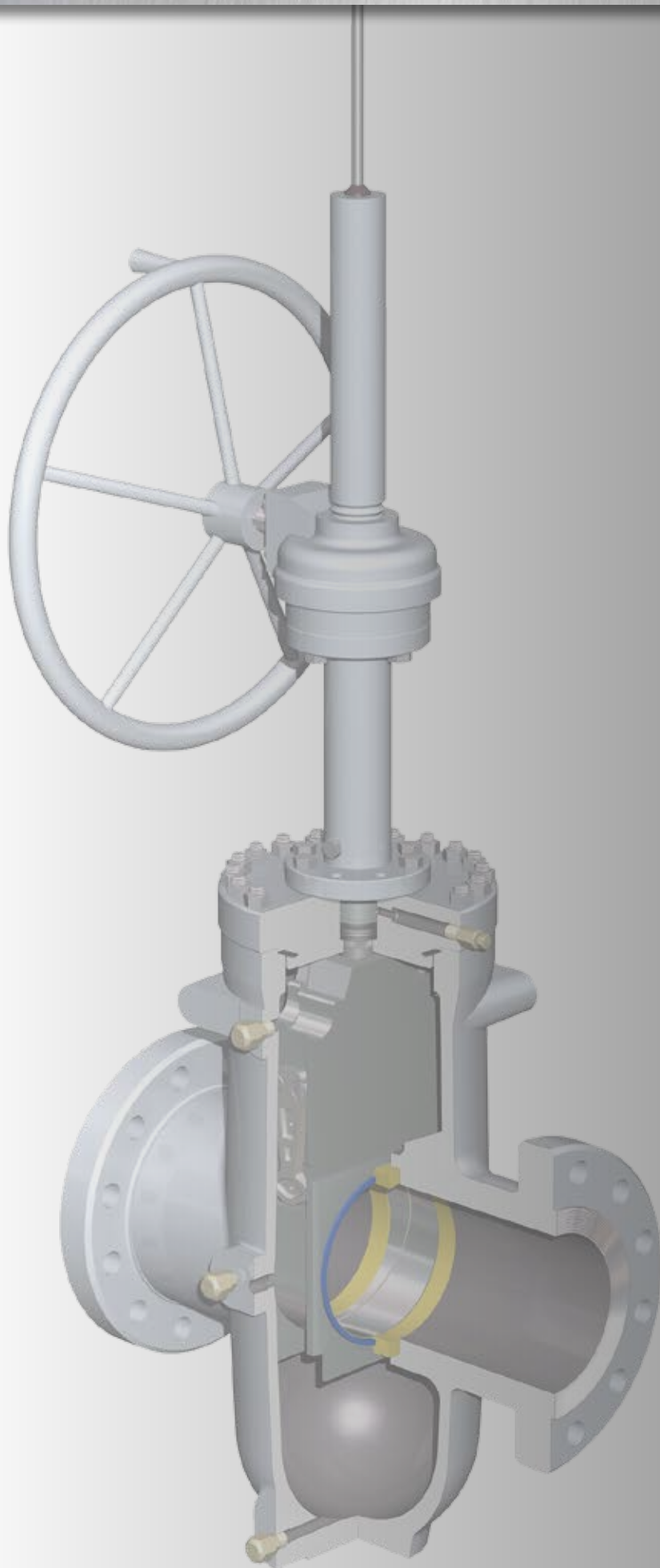

Table of Contents

WKM POW-R-SEAL GATE VALVES

Introduction.....	2
Design	3
Features.....	4
Options.....	5
Operation	6
Single Spring-Loaded (SLS) Seal.....	7
Thermal Relief System	8
Models M (Handwheel Operated)	9
Models E1C (Handwheel and Bevel Gear Operated)	10
Model E1C (Bevel Gear Operated).....	12
Operator Sizing Requirements.....	13
Operator Interface	14
Operator Interface Dimensions Topworks Data	15
Flow Coefficients (C_v)	16
Flow Coefficients (K_v)	17
Pressure Temperature Ratings.....	18
Trim Chart	20
Common Trims	21
Partial Open Flow Characteristics	22
CAMSERV Aftermarket Services for Valves and Actuation.....	23
Trademark Information	24

WKM Pow-R-Seal Gate Valves



Ville Platte, La.,
USA

Cameron is a leading provider of valves and measurement systems to the oil and gas industry. Our products are primarily used to control, direct, and measure the flow of oil and gas as it is moved from individual wellheads through flowlines, gathering lines, and transmission systems to refineries, petrochemical plants, and industrial centers for processing.

Cameron provides a wide range of valves for use in natural gas, LNG, crude oil, and refined products transmissions lines. The traditional CAMERON® fully welded ball valve product line has been combined with the GROVE®, RING-O®, TOM WHEATLEY®, ENTECH™, and TK® product lines. This broad offering has strengthened Cameron's ability to serve as a single source for a wide scope of customer requirements. Cameron also provides critical service valves for refinery, chemical, and petrochemical processing businesses, and for associated storage terminal applications, particularly through the ORBIT® and GENERAL VALVE® lines. These brands are complemented by WKM®, TBV™, and TEXSTEAM™ valve products and considerably expand the scope of our product offerings.

Cameron's WKM Pow-R-Seal™ gate valve's smooth continuous bore reduces turbulence. Additionally, the seat faces are outside the flow stream and are protected from contact with the lading whether the valve is in the open or closed position. The WKM Pow-R-Seal gate valve's full bore makes it possible to run pigs, scrapers, or hot tap cutters through the valves without danger of damaging the valve, lodging the scraper, or jamming it with metal cuttings.

DESIGN

Cameron's WKM Pow-R-Seal valve's design provides the following specific advantages for reliable performance and long life, even in fluid, gas, steam, and hot water critical services up to 1000° F (538° C).

Protection of Seat Faces

Seat faces are outside the flow stream and in full contact with the gate, in both fully open and fully closed positions, greatly extending the seat life.

Smooth, Continuous Conduit for Flow

Destructive turbulence is nearly eliminated. In a full-bore valve, pressure drop through the valve is no greater than that through an equal length of equal diameter pipe.

Tight Mechanical Seal and Double Block-and-Bleed Capability

The WKM Pow-R-Seal valve's parallel expanding gate design provides a tight mechanical seal, upstream and downstream simultaneously, which is normally unaffected by pressure variations or vibration.

Metal-to-Metal Mechanical Sealing

The seal is unaffected by pressure surges, vibration, or heat under normal operating conditions. First, the seat insert contacts the gate. Then, the insert is compressed and a metal-to-metal seal is established.

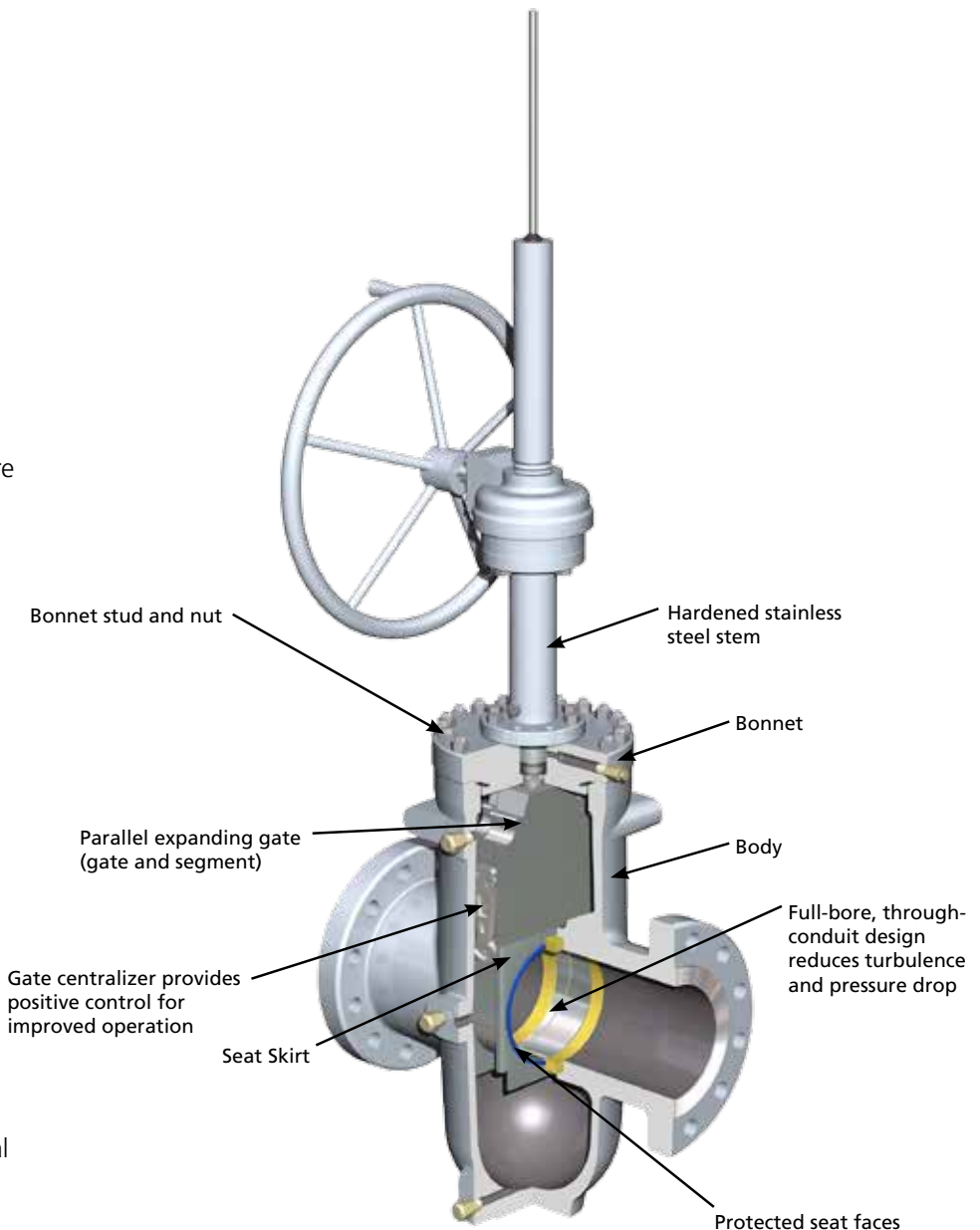

Commonly Used Applications

- Pumps station isolation
- Launchers and receivers
- Decoking systems
- Gathering lines

FEATURES

1. Through-Conduit Parallel Expanding Gate Valve

- Provides a tight mechanical seal
- Full-bore design reduces pressure drop and allows passage of all types of scrapers (pigs)
- Nickel-plated gate and segment standard

2. Fugitive Emissions-Tested SLS Stem Seal*

- Stem seal is completely contained in the bonnet
- Stem is centralized by bearings
- Nickel-plated stem standard
- Seal is self-adjusting and does not depend on plastic packing
- PTFE compound resists virtually all ladings
- Pedestal supports the seal and acts as a stem scraper
- 6" to 24" (150 mm to 600 mm) Class 300 to 900 valves are fire-tested to API 6FA 3rd Edition

3. Interference Fit Seats

- Double sealing and in-line replaceable
- Upstream and downstream sealing
- Block-and-bleed per API 6D standards
- Simple design is resistant to dirty service
- Insert initiates the seal and helps clean the gate**
- Seats are compatible with virtually all ladings
- Seats may be lubricated to promote long life, reduce operating torques or effect a seal in an emergency
- Fire-tested to API 6FA 3rd Edition

4. Bolted Bonnet Valve is In-Line Repairable

- Bonnet seal resists virtually all landings
- Design provides metal-to-metal, tight sealing ideal for high temperature applications

5. Yoke-Tube Upper Flanges Comply with MSS-SP102 Standards

- Simplifies operator mounting
- Can also be manufactured to comply with ISO 5240

6. Single-Piece Cast Body Center Section

- Provides the necessary strength to resist pipeline bending
- Smooth shape reduces stress concentrations
- Made from pressure vessel quality steel

7. Valve Stroke is Established by Manufacturing Tolerances

- Stays in adjustment

8. LeverLock® Gate Centralizer***

- Retains gate and segment assembly in a neutral position during opening and closing travel
- Permits expansion of the assembly at the proper moment for seating

* For Model E-1C; does not apply to high-temperature valves. In-house FE testing only.

** High-temperature valves do not have insert

*** Standard on 6" and larger valves

OPTIONS

Bonnet Seal

- 6" to 12" (150 mm to 300 mm): flat metal gasket
- 14" to 24" (350 mm to 600 mm): O-ring seal
- High-temperature valves: spiral-wound metal gasket with a non-asbestos filler

Options

- Lubrication, packing, drain extensions
- Stem and yoke tube extensions
- Variety of coatings (coal tar epoxy for buried service, two- to three-part coating systems for marine environment, inorganic zinc rich epoxy, etc.)
- HF-6 overlay is available on request for the gate segment assembly and seat sealing surfaces
- Handwheel operator* (position indicator standard)
- Bevel gear operator (position indicator standard)
- Less gearing (bare stem)
- Electric motor operator
- Several types of body cavity thermal relief systems available
- Variety of paint and coatings

* 6" through 10" (150 mm through 250 mm) Class 300 to 900 valves and 12" (300 mm) Class 300 to 600 valves only are available in selected sizes.



OPERATION

60 years of worldwide service in oil, gas, chemicals, water, slurry, and multiproduct applications has established the WKM Pow-R-Seal valve as one of the most trusted gate valves, where safety and seal reliability are critical.

The parallel expanding gate design provides a tight mechanical seal which is normally unaffected by vibrations or pressure variations.

The rigid, cast steel body resists pipeline bending

moments which could affect seat sealing in other valves.

PTFE seals on both faces of the valve provide drop tight sealing, while metal-to-metal contact between the seals and gate mechanism provides tight shutoff.

All-metal seals also are available for service to 1000° F (538° C), where leakage rates comply with API 6D and ISO 5208 standards.

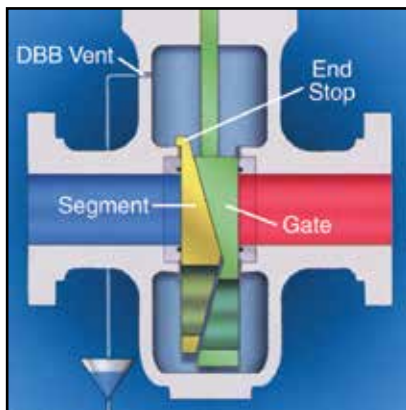

Sealed Closed

In the fully closed position, the segment has engaged with an end stop and the gate is wedged downward, expanding the segment and gate so that they form a tight mechanical closure against the upstream and downstream seats. Venting the body cavity will provide total, tight shutoff.

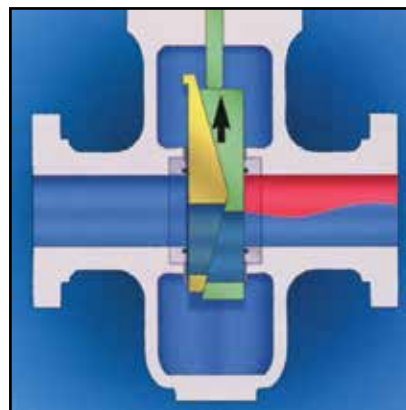

Mid-Travel

During travel towards opening, the gate slides across the wedge angle of the segment, collapsing the assembly so that it travels freely between the seal faces. The patented LeverLock gate centralizer holds the mechanism in the neutral position until seal expansion is required.

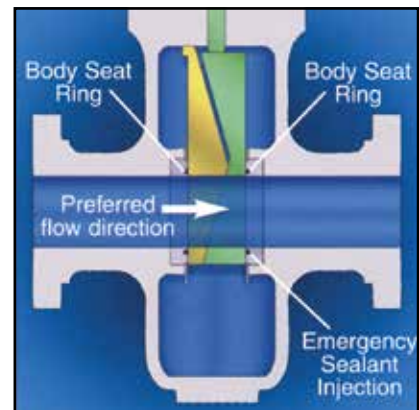

Fully Open

When the bore in the segment is aligned with the conduit bore, an end stop prevents further travel and the gate slides across the wedge angle, expanding the gate and the segment, isolating the flow from the body. The preferred flow direction ensures easier operation.

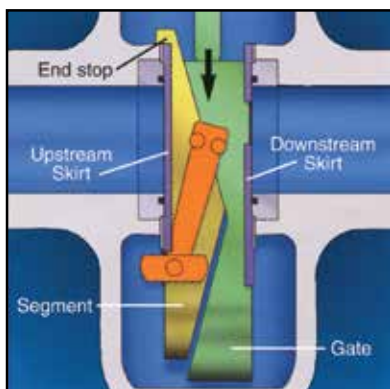

LeverLock Mechanism

The lever arm is held parallel to the gate faces by the skirt plates while the assembly is moving through its stroke. Near end-of-travel, the skirt allows the lever to tilt. The gate and segment slide against their angled faces, creating the expanding seal action. In their final position, the gate and segment are mechanically secured in place. The skirt plates are guide rails at the sides of the gate. The skirts align the gate and segments with the seats.

Single Spring-Loaded (SLS) Seal

FEATURES AND BENEFITS

The SLS stem seal system is designed to provide optimum performance while requiring minimal maintenance. Our in-house lab tests have shown FE leak rates below 500 ppm.

Testing and Certifications

- Fire tests per API 6FA, BS 6755 Part 11
- ISO 10497

Design

- Single spring-loaded lip seal
- Lantern ring
- Chevron ring(s)
- Lower pedestal
- Upper adapter

Features

- Self-adjusting seal designed to reduce maintenance
- No plastic packing required to establish an effective seal
- Four separate sealing bands to promote reliability
- Filled PTFE shell backed with a corrosion-resistant alloy spring (making it suitable for virtually all line media)
- Metal spring provides an initial seal and uniform loading over a wide temperature range
- Lantern ring acts as a spacer in conjunction with the upper adapter as a bearing to center the stem
- Lower pedestal support seal acts as a stem wiper to keep contaminants away from sealing members
- Chevron ring(s) act as an emergency seal, should it be necessary to inject plastic packing, and keeps foreign matter away from the seal

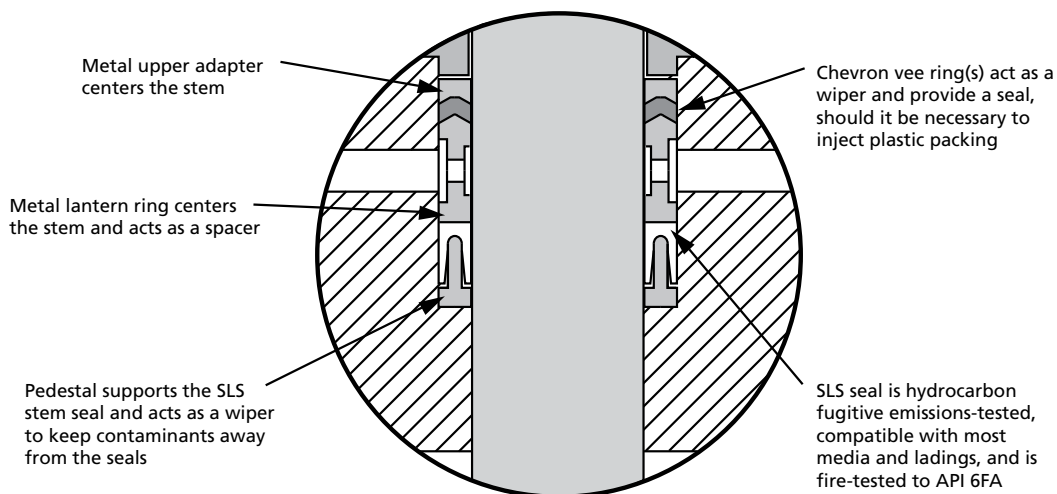

Thermal Relief System

OPERATION

Because of the split gate design, it is possible for excess body pressure to develop in the body cavities of closed valves. This usually results from heating that takes place in the valves while in liquid service. A thermal body cavity relief system is provided to relieve this excess body pressure. Thermal relief systems which direct excess body pressure to the upstream conduit are standard. This system consists of two needle valves, a check valve,

tubing and two fittings. Body pressure greater than the segment conduit pressure causes the check valve to unseat and relieve excess pressure to the upstream conduit. The needle valves must be kept open while the valve is in service. These needle valves can be used to isolate the line pressure to service the relief systems, as needed.

Typical Thermal Body Cavity Relief Arrangement

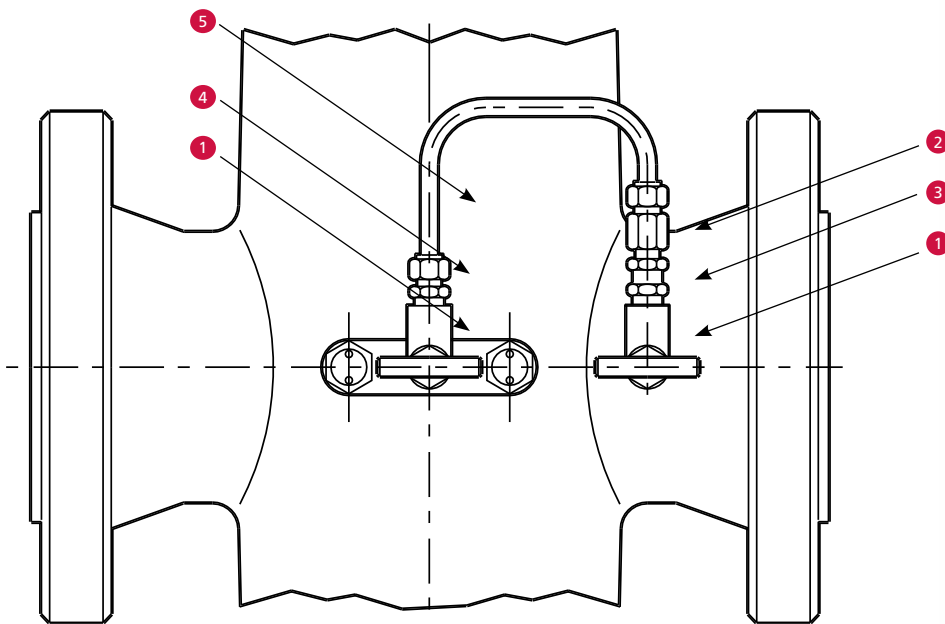

Item	Part	Qty.
1	Needle Valve	2
2	Female Tubing Connector	1
3	Check Valve	1
4	Male Tubing Connector	1
5	Tubing	1
	Tag (Not Shown)	2
	Wire (Not Shown)	1

Notes: These items are on the lettered side of the valve (letters not shown in diagram above).
Special thermal relief systems are available upon request.

2" to 4" (50 mm to 100 mm) Classes 600, 900, and 1500 MODELS M (HANDWHEEL OPERATED)

Max. WP at 100° F (38° C)	
Class 600:	1500 psi CWP 2250 psi Test
Class 900:	2250 psi CWP 3375 psi Test
Class 1500:	3750 psi CWP 5625 psi Test

PRINCIPAL DIMENSIONS

N = Number of turns to fully open or close valve

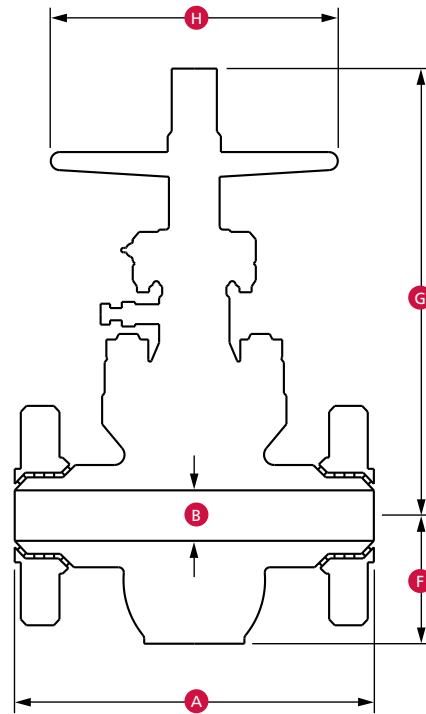

Class 600

Size in. (mm)	A	B	F	G	H	N	Weight lb (kg)		
							FE	WE	F x W
2 (50)	11-1/2 (292)	2-1/16 (52)	4-13/16 (122)	17-3/4 (451)	12 (305)	16 -	90 (41)	72 (33)	84 (38)
3 (80)	14 (356)	3-3/16 (81)	6-15/16 (176)	23-7/8 (606)	12 (305)	20 -	180 (82)	144 1(65)	155 (70)
4 (100)	17 (432)	4-1/8 (105)	8-5/8 (219)	27 (686)	14 (356)	20 -	345 (156)	259 (117)	245 (111)

Class 900

2 (50)	14-1/2 (368)	2-1/16 (52)	5-1/16 (129)	17-3/4 (451)	12 (305)	16 -	150 (68)	72 (33)	105 (48)
3 (80)	15 (381)	3-3/16 (81)	7-5/16 (186)	23-7/8 (606)	12 (305)	20 -	265 (120)	193 (88)	247 (112)
4 (100)	18 (457)	4-1/8 (105)	9-1/16 (230)	28-1/2 (724)	18 (457)	20 -	515 (234)	390 (177)	417 (189)

Class 1500

2 (50)	14-1/2 (368)	2-1/16 (52)	5-1/16 (129)	17-3/4 (451)	12 (305)	16 -	150 (68)	72 (33)	105 (48)
3 (80)	18-1/2 (470)	3-3/16 (81)	7-5/16 (186)	23-7/8 (606)	12 (305)	20 -	295 (134)	215 (98)	242 (110)
4 (100)	21-1/2 (546)	4-1/8 (105)	9-1/16 (230)	28-1/2 (724)	18 (457)	20 -	530 (240)	403 (183)	325 (147)

Flange dimensions conform to American National Standards Institute Standard B16.5, 1981. Information on power-actuated and other types of valves available on application.

6" to 12" (150 mm to 300 mm) Classes 300 and 600

MODELS E1C

(HANDWHEEL AND BEVEL GEAR OPERATED)

Max. WP at 100° F (38° C)	
Class 300:	750 psi CWP 1125 psi Test
Class 600:	1500 psi CWP 2250 psi Test
Class 900:	2250 psi CWP 3375 psi Test
Class 1500:	3750 psi CWP 5625 psi Test

PRINCIPAL DIMENSIONS

N = Number of turns of handwheel or bevel gear operator handwheel to fully open or close valve.

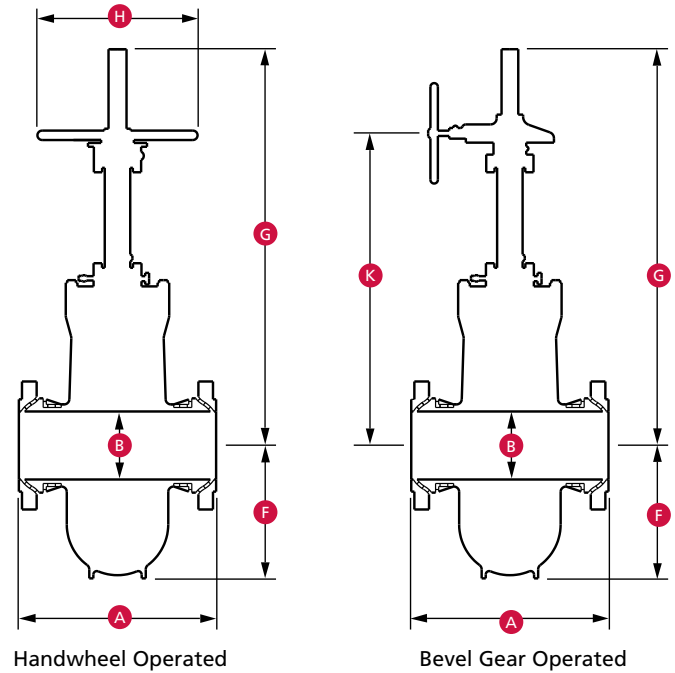

Class 300

Size in. (mm)	A	B	F	G HWO	G BGO	H	K	N HWO	N BGO	Weight lb (kg) HWO			Weight lb (kg) BGO		
										FE	WE	F x W	FE	WE	F x W
6 (150)	15-7/8 (403)	6 (152)	12-1/2 (318)	45-1/4 (1149)	46-1/4 (1175)	24 (610)	30-11/16 (779)	29 -	114 -	472 (214)	397 (180)	400 (181)	500 (227)	445 (202)	470 (213)
8 (200)	16-1/2 (419)	8 (203)	16 (406)	57-1/4 (1454)	56-1/4 (1429)	24 (610)	36-11/16 (932)	37 -	146 -	853 (387)	751 (341)	805 (365)	903 (410)	845 (383)	895 (406)
10 (250)	18 (457)	10 (254)	20 (508)	63-1/4 (1607)	64-1/4 (1632)	24 (610)	44-11/16 (1135)	45 -	180 -	1345 (610)	1200 (544)	1273 (577)	1475 (669)	1380 (626)	1448 (657)
12* (300)	30 (762)	12 (305)	22-3/4 (578)	73-3/8 (1864)	74-5/8 (1895)	30 (762)	51-11/16 (1313)	40 -	239 -	-	-	-	1950 (885)	1670 (757)	1880 (853)

Class 600

6 (150)	22 (559)	6 (152)	12-5/8 (321)	45-1/4 (1149)	46-1/4 (1175)	24 (610)	30-11/16 (779)	29 -	114 -	595 (270)	495 (225)	545 (247)	695 (315)	575 (261)	635 (288)
8 (200)	26 (660)	8 (203)	15-1/2 (394)	57-1/4 (1454)	56-1/4 (1429)	24 (610)	36-11/16 (932)	37 -	146 -	1028 (466)	730 (331)	865 (392)	1075 (488)	895 (406)	990 (449)
10 (250)	31 (787)	10 (254)	19-3/4 (502)	64-7/8 (1648)	66-1/8 (1680)	24 (610)	45-3/16 (1148)	34 -	203 -	1735 (787)	1370 (621)	1505 (683)	1895 (860)	1585 (719)	1835 (832)
12 (300)	33 (838)	12 (305)	23 (584)	73-3/8 (1864)	74-5/8 (1895)	30 (762)	51-11/16 (1313)	40 -	239 -	2525 (1145)	2360 (1070)	2480 (1125)	3030 (1374)	2250 (1021)	2360 (1070)

* 12" (300 mm) Class 300 valves have Class 400 end-to-end dimensions.

6" to 12" (150 mm to 300 mm) Classes 900 and 1500 (RTJ)

MODELS E1C

(HANDWHEEL AND BEVEL GEAR OPERATED)

Max. WP at 100° F (38° C)	
Class 300:	750 psi CWP 1125 psi Test
Class 600:	1500 psi CWP 2250 psi Test
Class 900:	2250 psi CWP 3375 psi Test
Class 1500:	3750 psi CWP 5625 psi Test

PRINCIPAL DIMENSIONS

N = Number of turns of handwheel or bevel gear operator handwheel to fully open or close valve.

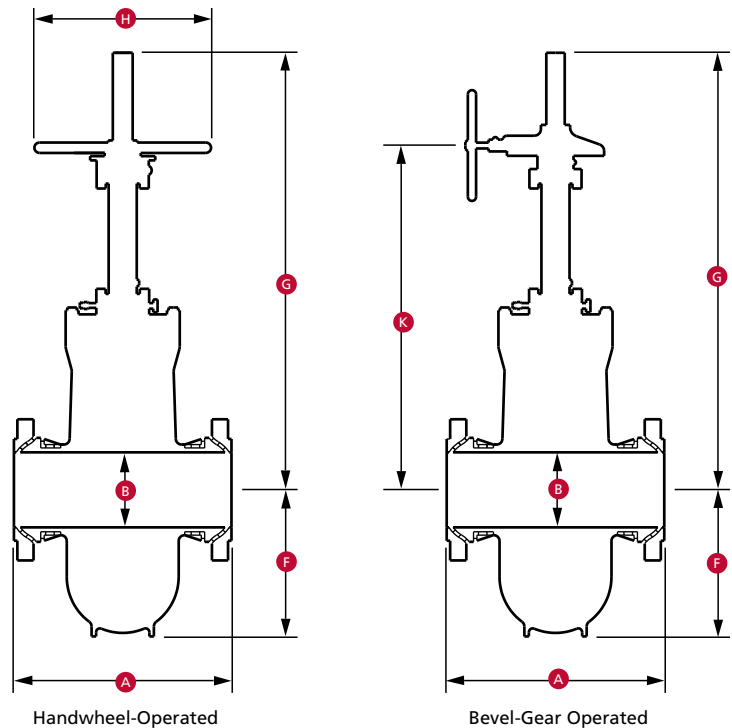

Class 900

Size in. (mm)	A	B	F	G HWO	G BGO	H	K	N HWO	N BGO	Weight lb (kg) HWO			Weight lb (kg) BGO		
										FE	WE	F x W	FE	WE	F x W
6 (150)	24 (610)	6 (152)	12-7/8 (327)	45-1/4 (1149)	46-1/4 (1175)	24 (610)	30-3/4 (781)	29	114	743 (337)	577 (262)	625 (283)	805 (365)	565 (256)	680 (308)
8 (200)	29 (737)	8 (203)	15-3/4 (400)	57-1/4 (1454)	56-1/4 (1429)	24 (610)	36-3/4 (933)	37	146	1272 (577)	1040 (472)	1180 (535)	1329 (603)	1180 (535)	1238 (562)
10 (250)	33 (838)	10 (254)	20-1/8 (511)	64-7/8 (1648)	66-1/8 (1680)	30 (762)	45-1/4 (1149)	34	203	2250 (1021)	1930 (875)	2085 (946)	2315 (1050)	1875 (850)	2185 (991)
12 (300)	38 (965)	12 (305)	23-1/2 (597)	-	73-3/4 (1873)	30 (762)	56-5/8 (1438)	40	318	3392 (1539)	2725 (1236)	2860 (1297)	3600 (1633)	2880 (1306)	3276 (1486)

Class 1500 (RTJ)

6 (150)	28 (711)	5-3/4 (146)	14-5/8 (371)	-	61 (1549)	-	49 (1245)	22	-	-	-	-	1735 (788)	1486 (676)	1611 (732)
8 (200)	33-1/8 (841)	7-5/8 (194)	18-1/4 (464)	-	66-1/2 (1689)	-	54-1/2 (1384)	29	-	-	-	-	3181 (1446)	2979 (1354)	3080 (1400)
10 (250)	39-3/8 (1000)	9-1/2 (241)	22-1/4 (565)	-	79 (2007)	-	67 (1702)	36	-	-	-	-	4094 (1861)	3492 (1587)	3793 (1724)
12 (300)	45-1/8 (1146)	11-3/8 (289)	26-3/8 (670)	-	90 (2286)	-	72 (1829)	-	-	-	-	-	7603 (3456)	6443 (2929)	7028 (3195)

* 12" (300 mm) Class 300 valves have Class 400 end-to-end dimensions.

14" to 24" (350 mm to 600 mm) Classes 300, 600, and 900

MODELS E1C (BEVEL GEAR OPERATED)

Max. WP at 100° F (38° C)	
Class 300:	750 psi CWP 1125 psi Test
Class 600:	1500 psi CWP 2250 psi Test
Class 900:	2250 psi CWP 3375 psi Test

PRINCIPAL DIMENSIONS

N = Number of turns of handwheel or bevel gear operator handwheel to fully open or close valve.

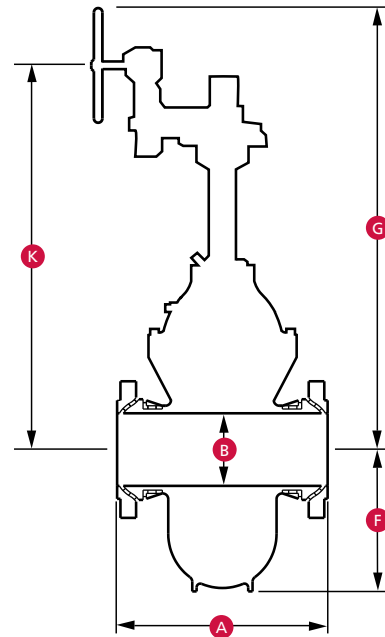

Class 300

Size in. (mm)	A	B	F	G	K	N	Weight lb (kg)		
							FE	WE	F x W
14* (350)	32-1/2 (826)	13-1/4 (337)	25-1/4 (641)	65-7/8 (1673)	53 (1346)	177 -	2632 (1194)	2230 (1012)	2500 (1134)
16 (400)	33 (838)	15-1/4 (387)	28-1/8 (714)	83-9/16 (2122)	58-3/8 (1483)	167 -	3450 (1565)	3015 (1368)	3310 (1501)
18 (450)	36 (914)	17-1/4 (438)	31 (787)	86-13/16 (2205)	65-5/16 (1659)	190 -	4650 (2109)	4260 (1932)	4375 (1984)
20 (500)	39 (991)	19-1/4 (489)	35-1/4 (895)	106-1/4 (2699)	73-7/8 (1876)	211 -	6248 (2834)	5780 (2622)	6000 (2722)
24* (600)	48-1/2 (1232)	23-1/4 (591)	42 (1067)	115-3/4 (2940)	86-3/8 (2194)	253 -	10,678 (4843)	9550 (4332)	10,240 (4645)

Class 600

14 (350)	35 (889)	13-1/4 (337)	25-9/16 (649)	69-3/4 (1772)	53-1/2 (1359)	177 -	3240 (1470)	2931 (1329)	3000 (1361)
16 (400)	39 (991)	15-1/4 (387)	28-1/8 (714)	81-1/8 (2061)	61-1/4 (1556)	167 -	4420 (2005)	3950 (1792)	4160 (1887)
18 (450)	43 (1092)	17-1/4 (438)	31-5/8 (803)	86-1/2 (2197)	66-5/8 (1692)	190 -	5705 (2588)	5115 (2320)	5200 (2359)
20 (500)	47 (1194)	19-1/4 (489)	36 (914)	98-1/8 (2492)	73-7/8 (1876)	211 -	7595 (3445)	7115 (3227)	6605 (2996)
24 (600)	55 (1397)	23-1/4 (591)	42-1/4 (1073)	113-1/2 (2883)	87-7/8 (2232)	253 -	12,994 (5894)	11,380 (5162)	12,730 (5774)

Class 900

14 (350)	40-1/2 (1029)	12-3/4 (324)	26-1/8 (664)	69-3/4 (1772)	53-1/2 (1359)	-	5200 (2359)	4902 (2224)	4902 (2224)
16 (400)	44-1/2 (1130)	14-3/4 (375)	30-1/4 (768)	81-1/8 (2061)	66-5/8 (1692)	174 -	7346 (3332)	6435 (2919)	6959 (3155)
18 (450)	48 (1219)	16-3/4 (425)	33 (838)	92 (2337)	-	-	11,814 (5359)	10,226 (4638)	11,020 (4999)
20 (500)	52 (1321)	18-5/8 (473)	36 (914)	103 (2616)	-	-	15,581 (7067)	14,265 (6470)	14,866 (6743)
24 (600)	61 (1549)	22-1/2 (572)	44-1/2 (1130)	113-1/2 (2883)	87-7/8 (2232)	-	20,467 (9284)	18,561 (8419)	19,887 (9021)

*14" to 24" (350 mm to 600 mm) Class 300 valves have Class 400 end-to-end dimensions.
Note: 30" and 36" (750 mm and 900 mm). Class 300 and 600 prices are available upon request.

OPERATOR SIZING REQUIREMENTS

Model M – 2" to 4" (50 mm to 100 mm) ASME Classes 150 to 1500

Valve Size in. (mm)	ASME Class	ASME Working Pressure (psig)	Stem Thread			Recommended Operating Thrust (lbf)	Recommended Operating Torque (ft-lbf)	Block-and-Bleed Thrust (lbf)	Block-and-Bleed Torque (ft-lbf)	Maximum Allowable Thrust (lbf)	Maximum Allowable Torque (ft-lbf)	Total Stem Travel in. (mm)	Stem Nut Turns-to-Open Valve
			Size in.	Pitch in.	Lead in.								
2 (50)	150	290	0.875	0.167	0.167	457	3	535	4	12,597	93	2.63 (67)	16
2 (50)	300	750	0.875	0.167	0.167	1183	9	1383	10	12,597	93	2.63 (67)	16
2 (50)	600	1500	0.875	0.167	0.167	2366	17	2766	20	12,597	93	2.63 (67)	16
2 (50)	900	2250	0.875	0.167	0.167	3549	26	4149	30	12,597	93	2.63 (67)	16
2 (50)	1500	3750	0.875	0.167	0.167	5914	43	6915	51	12,597	93	2.63 (67)	16
3 (80)	150	290	1.000	0.200	0.200	803	7	1115	9	16,027	136	4.03 (102)	21
3 (80)	300	750	1.000	0.200	0.200	2078	18	2884	25	16,027	136	4.03 (102)	21
3 (80)	600	1500	1.000	0.200	0.200	4155	35	5769	49	16,027	136	4.03 (102)	21
3 (80)	900	2250	1.000	0.200	0.200	6233	53	8653	74	16,027	136	4.03 (102)	21
3 (80)	1500	3750	1.000	0.200	0.200	10,388	88	14,422	123	16,027	136	4.03 (102)	21
4 (100)	150	290	1.250	0.250	0.250	1327	14	1783	19	25,442	271	4.88 (124)	20
4 (100)	300	750	1.250	0.250	0.250	3432	37	4610	49	25,442	271	4.88 (124)	20
4 (100)	600	1500	1.250	0.250	0.250	6864	73	9221	98	25,442	271	4.88 (124)	20
4 (100)	900	2250	1.250	0.250	0.250	10,297	110	13,831	147	25,442	271	4.88 (124)	20
4 (100)	1500	3750	1.250	0.250	0.250	17,161	183	23,052	245	25,442	271	4.88 (124)	20

Model E1C – 6" to 24" (150 mm to 600 mm) ASME Classes 300 to 900

Valve Size in. (mm)	ASME Class	ASME Working Pressure (psig)	Stem Thread			Recommended Operating Thrust (lbf)	Recommended Operating Torque (ft-lbf)	Block-and-Bleed Thrust (lbf)	Block-and-Bleed Torque (ft-lbf)	Maximum Allowable Thrust (lbf)	Maximum Allowable Torque (ft-lbf)	Total Stem Travel in. (mm)	Stem Nut Turns-to-Open Valve
			Size in.	Pitch in.	Lead in.								
6 (150)	300	750	1.50	0.250	0.250	6626	82	8179	101	21,711	267	7.19 (183)	29
6 (150)	600	1500	1.50	0.250	0.250	13,252	163	16,358	201	21,711	267	7.19 (183)	29
6 (150)	900	2250	1.50	0.250	0.250	19,878	245	24,538	302	33,158	408	7.19 (183)	29
8 (200)	300	750	1.75	0.250	0.250	10,705	149	12,626	176	23,678	329	9.12 (232)	36
8 (200)	600	1500	1.75	0.250	0.250	21,410	298	25,253	351	26,577	370	9.12 (232)	36
8 (200)	900	2250	1.75	0.250	0.250	32,115	447	37,879	527	42,377	590	9.12 (232)	36
10 (250)	300	750	2.25	0.333	0.333	16,462	296	19,385	349	36,141	651	11.31 (287)	34
10 (250)	600	1500	2.25	0.333	0.333	32,924	593	3871	698	46,433	836	11.31 (287)	34
10 (250)	900	2250	2.25	0.333	0.333	49,386	889	58,156	1047	76,635	1380	11.31 (287)	34
12 (300)	300	750	2.25	0.333	0.333	21,911	395	27,588	497	52,472	945	13.38 (340)	40
12 (300)	600	1500	2.25	0.333	0.333	43,822	789	55,175	994	64,733	1166	13.38 (340)	40
12 (300)	900	2250	2.25	0.333	0.333	65,732	1184	82,763	1490	84,560	1523	13.38 (340)	40
14 (350)	300	750	2.00	0.250	0.500	25,138	477	32,355	614	78,209	1485	14.88 (378)	30
14 (350)	600	1500	2.00	0.250	0.500	50,276	955	64,709	1229	78,209	1485	14.88 (378)	30
14 (350)	900	2250	2.25	0.333	0.333	72,608	1308	101,857	1835	110,039	1982	14.88 (378)	45
16 (400)	300	750	2.50	0.400	0.800	33,517	868	39,174	1015	108,946	2822	16.88 (429)	21
16 (400)	600	1500	2.50	0.400	0.800	67,035	1736	78,348	2029	108,946	2822	16.88 (429)	21
16 (400)	900	2250	2.75	0.400	0.800	97,481	2681	146,275	4022	162,485	4468	17.38 (441)	22
18 (450)	300	750	2.50	0.400	0.800	41,440	1073	48,846	1265	113,120	2930	18.94 (481)	24
18 (450)	600	1500	2.50	0.400	0.800	82,881	2147	97,691	2530	113,120	2930	18.94 (481)	24
18 (450)	900	2250	3.00	0.400	0.400	123,194	2901	173,424	4084	185,236	4362	19.88 (505)	50
20 (500)	300	750	2.75	0.400	0.800	51,116	1406	60,201	1655	113,120	3111	21.12 (536)	27
20 (500)	600	1500	2.75	0.400	0.800	102,231	2811	120,401	3311	129,553	3562	21.12 (536)	27
20 (500)	900	2250	3.5	0.400	0.800	153,347	4953	248,075	8031	253,737	8196	21.12	27
22 (550)	300							No Design					
22 (550)	600	1500	3.00	0.400	0.800	123,768	3601	149,487	4349	118,661	3453	23.25 (591)	29
22 (550)	900							No Design					
24 (600)	300	750	3.00	0.400	0.800	72,557	2111	91,789	2671	113,120	3291	25.25 (641)	32
24 (600)	600	1500	3.00	0.400	0.800	145,115	4222	183,577	5341	203,038	5908	25.25 (641)	32
24 (600)	900	2250	3.75	0.400	0.800	214,524	7273	356,572	12,089	351,789	11,927		

- Note: 1. Use recommended operating thrust and torques for sizing bevel gear operators.
 2. Use block-and-bleed thrusts and torques for sizing power operators (electric, gas, hydraulic, etc.).
 3. Maximum operating thrust and torques are the maximum allowable for the valve.

OPERATOR INTERFACE

The operator interface on 6" through 12" (150 mm through 300 mm) valves is manufactured to comply with ISO 5210 and MSS-SP-102.

The operator interface on 14" (350 mm) and larger valves is manufactured to comply with MSS-SP-102.

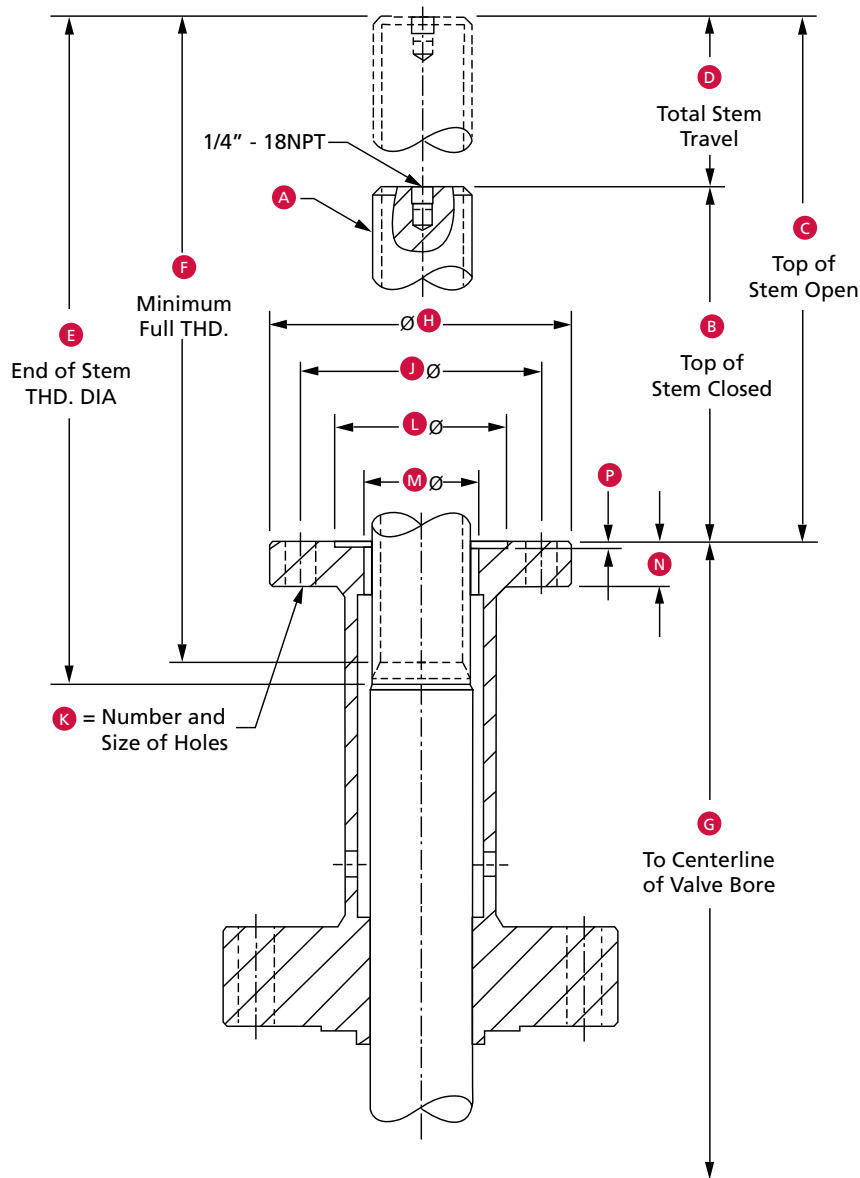

OPERATOR INTERFACE DIMENSIONS TOPWORKS DATA

Imperial

Size in.	Class	MSS FLG	A-NA-2G-L.H.	B	C	D	E	F	G	H	J	K	L	M	N	P
6	3-9C	FA14	1-1/2-.250P-.250L Single Lead Thread	8.31	15.50	7.19	16.44	16.06	26.88	7.00	5.50	4-0.69	3.955 3.945	2.50	1.03	0.178
8	3-9C	FA14	1-3/4-.250P-.250L Single Lead Thread	8.44	17.56	9.12	18.94	18.56	32.00	7.00	5.50	4-0.69	3.955 3.945	2.50	1.03	0.178
10	3-9C	FA16	2.25-.333P-.333L Single Lead Thread	9.38	20.69	11.31	24.38	24.00	42.13	8.38	6.50	4-0.81	5.230 5.220	3.12 3.75	1.50 2.75	0.230
12	3-6C	FA16	2.25-.333P-.333L Single Lead Thread	11.50	24.88	13.38	26.06	25.69	45.44	8.38	6.50	4-0.81	5.230 5.220	3.12	1.50	0.230
	9C	FA16	2.25-.333P-.333L Single Lead Thread	11.34	24.75	13.38	26.06	25.69	45.56	8.38	6.50	4-0.81	5.230 5.220	3.12	1.50	0.230
14	3-6C	FA16	2-.250P-.500L Double Lead Thread	9.56	24.38	14.81	27.50	26.88	50.44	8.38	6.50	4-0.81	5.230 5.220	3.12	1.50	0.230
16	3-6C	FA25	2-1/2-.400P-.800L Double Lead Thread	10.19	27.06	16.88	31.19	30.56	56.50	11.50	10.00	8-0.69	6.020 6.010	3.75	2.00	0.230
18	3-6C	FA25	2-1/2-.400P-.800L Double Lead Thread	9.31	28.25	18.94	32.69	32.19	63.88	11.50	10.00	8-0.69	6.020 6.010	3.75	2.00	0.230
20	3C	FA25	2-3/4-.400P-.800L Double Lead Thread	11.50	32.62	21.12	37.00	36.44	70.31	11.50	10.00	8-0.69	6.020 6.010	3.75	2.00	0.230
	6C	FA30	2-3/4-.400P-.800L Double Lead Thread	11.50	32.62	21.12	37.00	36.44	70.31	13.62	11.75	8-0.81	7.020 7.010	3.75	2.75	0.230
24	3C	FA25	3-.400P-.800L Double Lead Thread	12.37	37.62	25.25	43.06	42.56	85.19	11.50	10.00	8-0.69	6.020 6.010	3.75	2.00	0.230
	6C	FA35	3-.400P-.800L Double Lead Thread	12.37	37.62	25.25	43.06	42.56	85.19	16.12	14.00	8-1.12	8.520 8.510	4.00	3.25	0.230

Metric

Size mm	Class	MSS FLG	A-NA-2G-L.H.	B	C	D	E	F	G	H	J	K	L	M	N	P
150	3-9C	FA14	38.1-.250P-.250L Single Lead Thread	211	394	183	418	408	683	178	140	4-17.53	100.46 100.20	63.5	26.16	4.52
200	3-9C	FA14	44.45-.250P-.250L Single Lead Thread	214	446	232	481	471	813	178	140	4-17.53	100.46 100.20	63.5	26.16	4.52
250	3-9C	FA16	57.15-.333P-.333L Single Lead Thread	238	526	287	619	610	1070	213	165	4-20.57	132.84 132.59	79.25 95.25	38.1 69.85	5.84
300	3-6C	FA16	57.15-.333P-.333L Single Lead Thread	292	632	340	662	653	1154	213	165	4-20.57	132.84 132.59	79.25	38.1	5.84
	9C	FA16	57.15-.333P-.333L Single Lead Thread	288	629	340	662	653	1157	213	165	4-20.57	132.84 132.59	79.25	38.1	5.84
350	3-6C	FA16	50.8-.250P-.500L Double Lead Thread	243	619	376	699	683	1281	213	165	4-20.57	132.84 132.59	79.25	38.1	5.84
400	3-6C	FA25	63.5-.400P-.800L Double Lead Thread	259	687	429	792	776	1435	292	254	8-17.53	152.91 152.65	95.25	50.8	5.84
450	3-6C	FA25	63.5-.400P-.800L Double Lead Thread	9.31	718	481	830	818	1623	292	254	8-17.53	152.91 152.65	95.25	50.8	5.84
500	3C	FA25	69.85-.400P-.800L Double Lead Thread	292	829	536	940	926	1786	292	254	8-17.53	152.91 152.65	95.25	50.8	5.84
	6C	FA30	69.85-.400P-.800L Double Lead Thread	292	829	536	940	926	1786	346	298	8-20.57	178.31 178.10	95.25	69.85	5.84
600	3C	FA25	76.2-.400P-.800L Double Lead Thread	314	956	641	1094	1081	2164	292	254	8-17.53	152.91 152.65	95.25	50.8	5.84
	6C	FA35	76.2-.400P-.800L Double Lead Thread	314	956	641	1094	1081	2164	409	356	8-28.45	216.41 216.15	101.6	82.55	5.84

FLOW COEFFICIENTS (C_v)

The following chart outlines the C_v for through conduit gate valves having end-to-end dimensions and bore diameters in compliance with API 6D. *

Since C_v is a calculated number, the actual value may vary.

Valve Size in. (mm)	300	400	600	900	1500	2500
2 (50)	432	378	378	337	337	218
3 x 2 (80 x 50)	-	165	165	203	239	-
2-1/2 (65)	-	682	682	558	558	305
3 (80)	1155	1053	1109	1072	966	474
4 x 3 (100 x 80)	-	534	529	597	677	624
4 (100)	2176	1925	1944	1890	1730	725
6 x 4 (150 x 100)	-	886	944	943	1231	-
6 (150)	5300	4860	4577	4383	3622	2510
8 x 6 (200 x 150)	2499	-	3240	3588	2137	-
8 (200)	11,054	9345	8886	8416	6879	5227
10 x 8 (250 x 200)	5218	-	5036	7975	4859	-
12 x 8 (300 x 200)	3302	-	3892	-	-	-
10 (250)	18,856	15,771	14,533	14,087	11,283	8313
12 (300) (Note 1)	228,980	23,834	22,729	21,025	16,843	12,282
12 x 10 (300 x 250)	-	-	12,799	7299	-	-
14 (350) (Note 1)	30,883	29,921	28,837	23,846	20,336	-
16 x 14 (400 x 350)	-	-	21,096	-	-	-
16 (400)	42,224	41,022	39,144	33,358	27,548	21,396
20 x 16 (500 x 400)	-	15,761	-	-	-	-
18 (450)	55,740	54,277	51,368	45,004	-	-
20 (500)	70,386	68,680	64,559	56,871	-	-
22 (550)	86,869	85,422	80,279	-	-	-
24 (600) (Note 1)	106,835	103,504	97,240	84,836	-	-
26 (650)	123,222	120,829	114,905	-	-	-
28 (700)	144,355	142,391	135,267	-	-	-
30 (750)	170,229	163,776	157,401	133,706	-	-
36 (900)	245,362	236,147	224,424	-	-	-

* As Applicable.

Notes: 1. Class 300 valves have Class 400 end-to-ends in these size Pow-R-Seal designs. Use the Class 400 C_v .

FLOW COEFFICIENTS (K_v)

The following chart outlines the K_v for through conduit gate valves having end-to-end dimensions and bore diameters in compliance with API 6D. *

Since K_v is a calculated number, the actual value may vary.

Valve Size in. (mm)	300	400	600	900	1500	2500
2 (50)	373	327	327	291	291	188
3 x 2 (80 x 50)	-	142	145	175	207	-
2-1/2 (65)	-	590	590	483	483	264
3 (80)	999	911	959	927	835	410
4 x 3 (100 x 80)	-	462	458	516	585	540
4 (100)	1882	1665	1682	1635	1496	627
6 x 4 (150 x 100)	-	766	817	816	1065	-
6 (150)	4585	4204	3959	3792	3133	2172
8 x 6 (200 x 150)	2162	-	2803	3103	1849	-
8 (200)	9562	8084	7687	7280	5951	4522
10 x 8 (250 x 200)	4514	-	4356	6898	4204	-
12 x 8 (300 x 200)	2857	-	3367	-	-	-
10 (250)	16,312	13,643	12,572	12,186	9761	7191
12 (300) (Note 1)	25,070	20,617	19,662	18,188	14,570	10,624
12 x 10 (300 x 250)	-	-	11,072	6314	-	-
14 (350) (Note 1)	26,715	25,883	24,945	20,628	17,591	-
16 x 14 (400 x 350)	-	-	-	-	-	-
16 (400)	-	-	18,249	-	-	-
20 x 16 (500 x 400)	36,526	35,486	33,862	28,856	23,831	18,509
18 (450)	-	13,634	-	-	-	-
20 (500)	48,218	46,953	44,436	38,930	-	-
22 (550)	60,888	59,412	55,847	49,196	-	-
24 (600) (Note 1)	75,147	73,894	69,445	-	-	-
26 (650)	92,417	89,536	84,117	73,388	-	-
28 (700)	106,593	104,523	99,399	-	-	-
30 (750)	124,874	123,175	117,013	-	-	-
36 (900)	147,257	141,674	136,160	115,662	-	-
40 x 30 (1000 x 750)	-	-	-	60,464	-	-
36 (900)	212,251	204,279	194,138	-	-	-
42 x 36 (1050 x 900)	70,357	-	-	-	-	-
40 (1000)	266,697	265,814	265,814	-	-	-
42 (1050)	-	302,576	293,854	-	-	-
48 (1200)	-	-	408,871	-	-	-

* As Applicable.

Notes: 1. Class 300 valves have Class 400 end-to-ends in these size Pow-R-Seal designs. Use the Class 400 K_v.

PRESSURE TEMPERATURE RATINGS

Standard WCC Material

Temperature		Working Pressure by Class, psig					
°C	°F	150	300	400	600	900	1500
29° C to 38° C	20° F to 100° F	290	750	1000	1500	2250	3750
93° C	200° F	260	750	1000	1500	2250	3750
149° C	300° F	230	730	970	1455	2185	3640
204° C	400° F	200	705	940	1410	2115	3530
260° C	500° F	170	665	885	1330	1995	3325
316° C	600° F	140	605	805	1210	1815	3025
343° C	650° F	125	590	785	1175	1765	2940
371° C	700° F	110	570	755	1135	1705	2840
399° C	750° F	95	505	670	1010	1510	2520
427° C	800° F	80	410	550	825	1235	2060

Ref.: API 6D, ASME B16.34

Temperature		Working Pressure by Class, psig				
°C	°F	150	300	600	900	1500
-29° C to 38° C	-20° F to 100° F	19.8	51.7	103.4	155.1	258.6
50° C	122° F	19.5	51.7	103.4	155.1	258.6
100° C	212° F	17.7	51.5	103.0	154.6	257.6
150° C	302° F	15.8	50.2	100.3	150.5	250.8
200° C	392° F	13.8	48.6	97.2	145.8	243.2
250° C	482° F	12.1	46.3	97.2	139.0	231.8
300° C	572° F	10.2	42.9	85.7	128.6	214.4
325° C	617° F	9.3	41.4	82.6	124.0	206.6
350° C	662° F	8.4	40.0	80.0	120.1	200.1
375° C	707° F	7.4	37.8	75.7	113.5	189.2
400° C	752° F	6.5	34.7	69.4	104.2	173.6
425° C	797° F	5.5	28.8	57.5	86.3	143.8

General Notes: (a) Flanged end valve ratings terminate at 1000° F (538° C).

PRESSURE TEMPERATURE RATINGS

Standard WC6 Material

Temperature		Working Pressure by Class, psig				
°C	°F	150	300	600	900	1500
-29° C to 38° C	-20° F to 100° F	290	750	1500	2250	3750
93° C	200° F	260	750	1500	2250	3750
149° C	300° F	230	720	1445	2165	3610
204° C	400° F	200	695	1385	2080	3465
260° C	500° F	170	665	1330	1995	3325
316° C	600° F	140	605	1210	1815	3025
343° C	650° F	125	590	1175	1765	2940
371° C	700° F	110	570	1135	1705	2840
399° C	750° F	95	530	1065	1595	2660
427° C	800° F	80	510	1015	1460	2540
454° C	850° F	65	485	975	1350	2435
482° C	900° F	50	450	900	955	2245
510° C	950° F	35	320	640	650	1595
538° C	1000° F	20	215	430	430	1080

Temperature		Working Pressure by Class, psig				
°C	°F	150	300	600	900	1500
-28° C to 38° C	-20° F to 100° F	19.8	51.7	103.4	155.1	258.6
50° C	122° F	19.5	51.7	103.4	155.1	258.6
100° C	212° F	17.7	51.5	103.0	154.4	257.4
150° C	302° F	15.8	49.7	99.5	149.2	248.7
200° C	392° F	13.8	48.0	95.9	143.9	239.8
250° C	482° F	12.1	46.3	92.7	139.0	231.8
300° C	572° F	10.2	42.9	85.7	128.6	214.4
325° C	617° F	9.3	41.4	82.6	124.0	206.6
350° C	662° F	8.4	40.3	80.4	120.7	201.1
375° C	707° F	7.4	38.9	77.6	116.5	194.1
400° C	752° F	6.5	36.5	73.3	109.8	183.1
425° C	797° F	5.5	35.2	70.0	105.1	175.1
450° C	842° F	4.6	33.7	67.7	101.4	169.0
475° C	887° F	3.7	31.7	63.4	95.1	158.2
500° C	932° F	2.8	25.7	51.5	77.2	128.6
538° C	1000° F	1.4	14.9	29.8	44.7	74.5

General Notes: (a) Flanged end valve ratings terminate at 1000° F (538° C).

TRIM CHART

Service	Trim Code	Body and Bonnet	Gate and Segment	Seat	Stem Seal	Stem	Bolting	Fittings	Temperature Range
Waterflood, Corrosive	T-10	WCC Carbon Steel, Nickel-Plated	Carbon Steel 300-600, Low Alloy 900 Nickel-Plated	Carbon Steel, Nickel-Plated PTFE Insert	PTFE	Low Alloy Steel, Nickel-Plated	Alloy Steel NACE	Stainless Steel	-20° F to 250° F (-29° C to 121° C)
Standard 2" - 4" only	T-11	WCC Carbon Steel	Carbon Steel, Low Alloy Steel, Nickel-Plated	Carbon Steel, Nickel-Plated PTFE Insert	FKM Viton	Low Alloy Steel, Nickel-Plated	Alloy Steel	Carbon Steel	-20° F to 250° F (-29° C to 121° C)
Sour, Mildly Corrosive 2" and larger	T-24	WCC Carbon Steel	Carbon Steel 300-600, Low Alloy 900 Nickel-Plated	Carbon Steel, Nickel-Plated PTFE Insert	PTFE	Low Alloy Steel, Nickel-Plated	Alloy Steel NACE	Stainless Steel	-20° F to 250° F (-29° C to 121° C)
High-Temperature	T-30	WCC Carbon Steel	CA6NM Stainless Steel, HF-6 Hard Faced	Carbon Steel, HF-6 Hard Faced	Flexible Graphite	400 Series Stainless Steel	Alloy Steel	Stainless Steel	-20° F to 650° F (-29° C to 343° C)
High-Temperature	T-31	WC6 Carbon Steel	CA6NM Stainless Steel, HF-6 Hard Faced	A182 F11 Carbon Steel, HF-6 Hard Faced	Flexible Graphite	400 Series Stainless Steel	Alloy Steel	Stainless Steel	-20° F to 1000° F (-29° C to 538° C)
Low-Temperature, Non-Sour	T-36	LCC Carbon Steel Impact-Tested	Nickel-Plated Carbon Steel 300-600 Low Alloy Steel 900 Class	Carbon Steel, Nickel-Plated PTFE Insert	PTFE	Low Alloy Steel, Impact Nickel-Plated	Alloy Steel, Impact-Tested	Stainless Steel	-50° F to 250° F (-46° C to 121° C)
Low-Temperature, Sour	T-37	LCC Carbon Steel Impact-Tested	Nickel-Plated Carbon Steel 300-600 Low Alloy Steel 900 Class	Carbon Steel, Nickel-Plated PTFE Insert	PTFE	Low Alloy Steel, Impact Nickel-Plated	Alloy Steel, Impact-Tested	Stainless Steel	-50° F to 250° F (-46° C to 121° C)
Standard 6" and larger	T-101	WCC Carbon Steel	Carbon Steel 300-600, Low Alloy 900 Nickel-Plated	Carbon Steel, Nickel-Plated PTFE Insert	PTFE	Low Alloy Steel, Impact Nickel-Plated	Alloy Steel	Carbon Steel	-20° F to 250° F (-29° C to 121° C)
Standard Special Services 6" and larger	T-102	WCC Carbon Steel	Carbon Steel 300-600, Low Alloy 900 Nickel-Plated	Carbon Steel, Nickel-Plated PTFE Insert	PTFE	Low Alloy Steel, Impact Nickel-Plated	Alloy Steel	Carbon Steel	-20° F to 250° F (-29° C to 121° C)

COMMON TRIMS

Waterflood (Uninhibited) (T-10) – Carbon steel body/bonnet with wetted surface, ENP-plated, internal parts of corrosion-resistant materials.

Model M (Sizes 2" to 4", (50 mm to 100 mm), Classes 600 through 1500) Standard (T-11) – For non-corrosive aromatic service with concentration of MTBE to 100%.

Sour Gas and Oil (NACE MR0175) (T-24) – Primarily for sour gas and oil (NACE MR0175) where resistance to H₂S embrittlement is required. Also suitable for other chemicals, products or hydrocarbons when H₂S is present. May be used when CO₂ is present in smaller amounts than H₂S.

High-Temperature -20° F to 650° F (-29° C to 343° C) (T-30) – For higher temperature service where the corrosion resistance and wire drawing resistance of the stainless internals with stellite overlay are suitable. The limiting temperature is a function of the body material which follows the appropriate pressure rating table. (Ref. ASME Std. B16.34, 1977).

High-Temperature Up to 1000° F (538° C) (T-31) – For service above 550° F (288° C). Same qualifications as T-30, except metal-to-metal seating is only required for temperatures from 650° F to 1000° F (343° C to 538° C).

Low-Temperature -50° F (-46° C) NACE (T-36) – For essentially non-corrosive ladings, either liquid or gaseous. The pressure-retaining components (body, bonnet and bolting) are of impact-tested materials.

Low-Temperature Sour -50° F (-46° C) NACE (T-37) – Primarily for sour gas and oil (NACE MR0175) where resistance to H₂S embrittlement is required at -50° F (-46° C) service. The pressure-retaining components (body, bonnet and bolting) are of impact-tested materials. Also suitable for other chemicals, products or hydrocarbons when H₂S is present. Can be used when CO₂ is present in smaller amounts than H₂S.

Aromatic (to 40% MTBE, Fire-Tested API 6FA or ISO 10497) (T-101) – For essentially non-corrosive, non-sour aromatic or non-aromatic service with methanol or ethanol based corrosion inhibitors where up to 40% MTBE may be present.

High-Aromatic (Special Services for 6" to 24" [150 mm to 600 mm], Classes 300 to 1500) (T-102) – For non-corrosive aromatic service with concentration of MTBE, Ethanol, Methanol to 100 percent.

PARTIAL OPEN FLOW CHARACTERISTICS

The following graph approximates the flow coefficient, C_v or K_v , of gate valves as a function of the valve stroke going from closed to open. Note that this is an estimation only because of assumptions made in the valve stroke, as well as unpredictable flow characteristics around the gate-seat bore in the partially open position.

Gate valves are intended for on-off service. Intermittent throttling such as pressure equalization service is acceptable. Continuous throttling is not recommended. This information is provided only to facilitate the engineering of systems in the transition between open and closed positions of the valves. One example might be to evaluate the possibility of water hammer in liquid pipelines.

Partial Open Flow Characteristics (Through-Conduit Gate Valves)

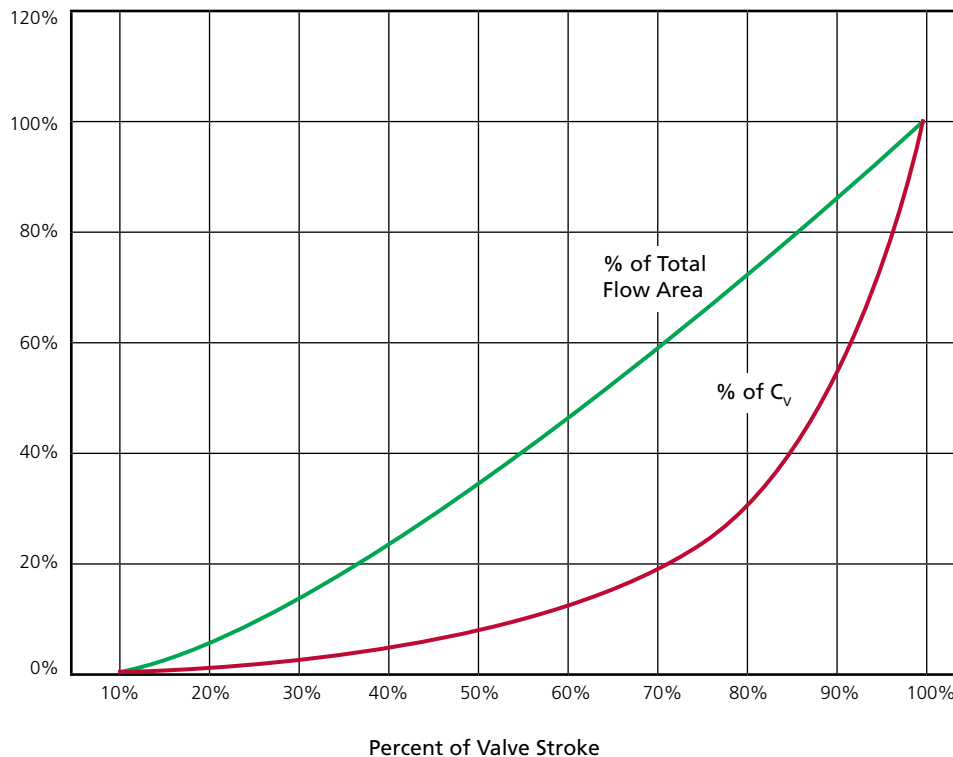

CAMSERV™ Aftermarket Services for Valves and Actuation

WE BUILD IT. WE BACK IT.



Global Network and Local Support

Cameron is well-positioned to deliver total aftermarket support, quickly and efficiently, with unmatched OEM expertise. Our highly skilled engineers and technicians are available around the clock, seven days a week, to respond to customer queries, troubleshoot problems, and offer reliable solutions.

Easily Accessible Parts and Spare Valves

- OEM spare valves, actuators, and parts (including non-Cameron brands)
- Handling, storage, packaging, and delivery
- Dedicated stocking program

Comprehensive Aftermarket Services Portfolio

- Parts and spare valves
- Repair
- Field services
- Preventative maintenance
- Equipment testing and diagnostics
- Remanufacturing
- Asset preservation
- Customer property management
- Training and recertification services
- Warranty

Customized Total Valve Care™ (TVC) Programs

Customized asset management plans that optimize uptime, availability, and dedicated services.

- Engineering consultancy
- Site management
- Flange management
- Startup and commissioning
- Spare parts and asset management
- Operational support





3250 Briarpark Drive, Suite 300
Houston, TX 77042
USA
Toll Free 1 800 323 9160

Learn more about WKM gate valves at:

www.c-a-m.com/WKM/gate

WKM@c-a-m.com



HSE Policy Statement

At Cameron, we are committed ethically, financially and personally to a working environment where no one gets hurt and nothing gets harmed.