

## W3PM WSPR Transceiver

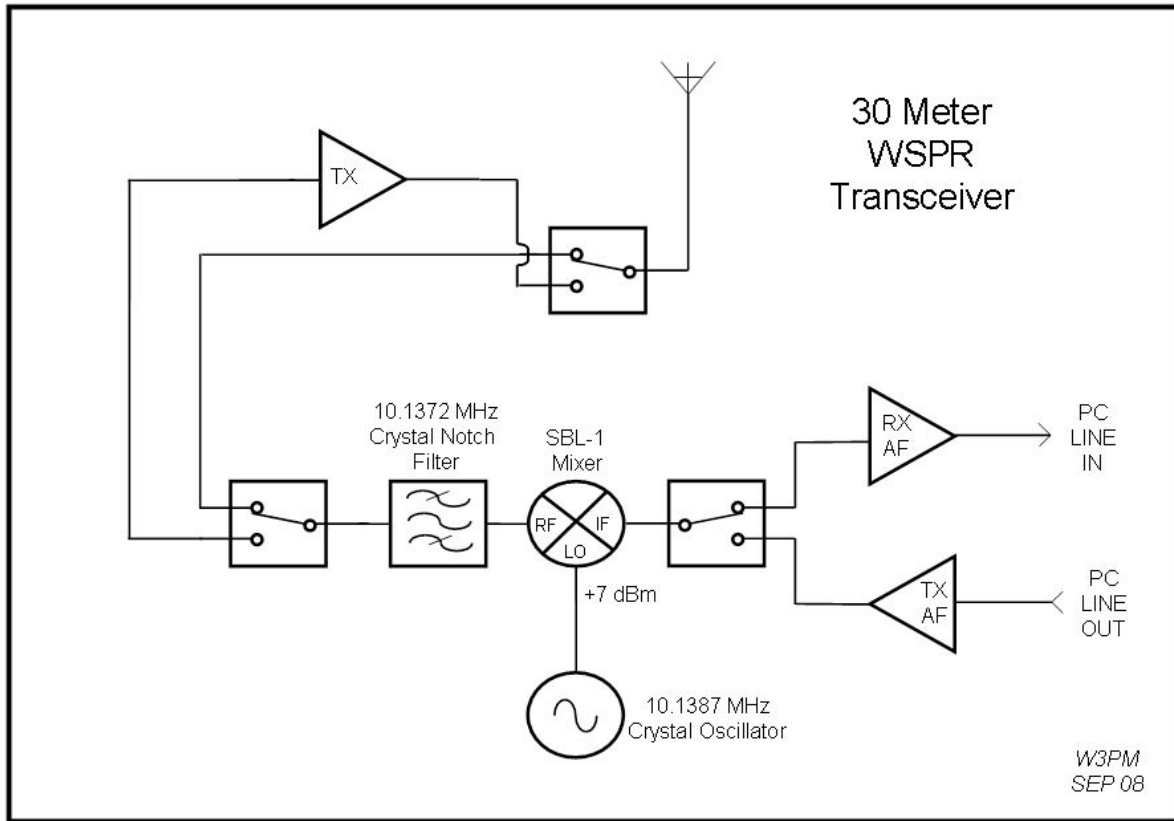

**Gene  
W3PM**

Weak Signal Reporter program Joe Taylor, uses a sound card to audio tones to SSB operating on sideband. In the sound audio from



**Marcus,  
GM4YRE**

Propagation (WSPR) is a developed by K1JT that computer generate modulate an transceiver upper receive mode card digitizes the

transceiver. The program scans a 200 Hz passband (the "QRSS window") looking for MEPT\_JT signals, and decodes them. This mode is usable with extremely weak signals. Most stations transmit at one watt or less and the exchange of reports with DX stations is commonplace. Although some WSPR activity can be found in all the HF bands, most activity currently takes place between 10.1401 and 10.1403 MHz. The following are sources for additional information:

General WSPR information - [http://physics.princeton.edu/pulsar/K1JT/WSPR\\_Instructions.TXT](http://physics.princeton.edu/pulsar/K1JT/WSPR_Instructions.TXT)

Program download - <http://physics.princeton.edu/pulsar/K1JT/WSPR.EXE>

WSPR reporting database - <http://wspnet.org>

This one watt 30 meter transceiver project began with the purchase of a few 10.140 MHz crystals for the very reasonable price of \$2.55 each from Expanded Spectrum Systems (N4ESS) in Tampa, FL. My original intent was to build a low power beacon for the 10.140 MHz QRSS window. After building the oscillator, I realized that a relatively simple SSB transceiver could be constructed for WSPR operation. The following is a description of the "proof of concept" WSPR transceiver that resulted from my efforts. This paper is not written as a construction article. However, enough information is included to easily reproduce the transceiver and put it on the air using a minimum amount of test equipment.

### Fig.1 - Block Diagram

The block diagram above outlines a basic direct conversion upper sideband transceiver that derives the audio IF (1400 – 1600 Hz) from the computer soundcard. Because the entire WSPR passband is only 200 Hz wide, a single crystal notch filter is used to eliminate the 10.1372 MHz lower sideband. To further simplify construction, class C amplifiers are used in the transmitter. WSPR transmissions use a continuous phase 4-FSK with tone separation of 1.46 Hz that does not require linear amplification.

I used the "Ugly" construction method to build this transceiver. Individual modules were built, tested and then mounted in tin Altoids boxes. The individual modules were then wired together and mounted in a larger project box. I used a front panel meter to monitor transmitter current. Although construction is straightforward, the adjustment of the local oscillator and notch filter may pose a challenge to builders that do not have access to test equipment. The entire WSPR passband is only 200 Hz wide; therefore, it is imperative that the oscillator is adjusted within a few Hz of 10.138700 MHz. The LSB notch also has to be adjusted within a few Hz of 10.137200 MHz. Two alignment procedures are included in this paper. The alternate method uses a minimum of test equipment but does require either a low power wattmeter or oscilloscope to set the output power to one watt.

### 10.1387 MHz LOCAL OSCILLATOR:

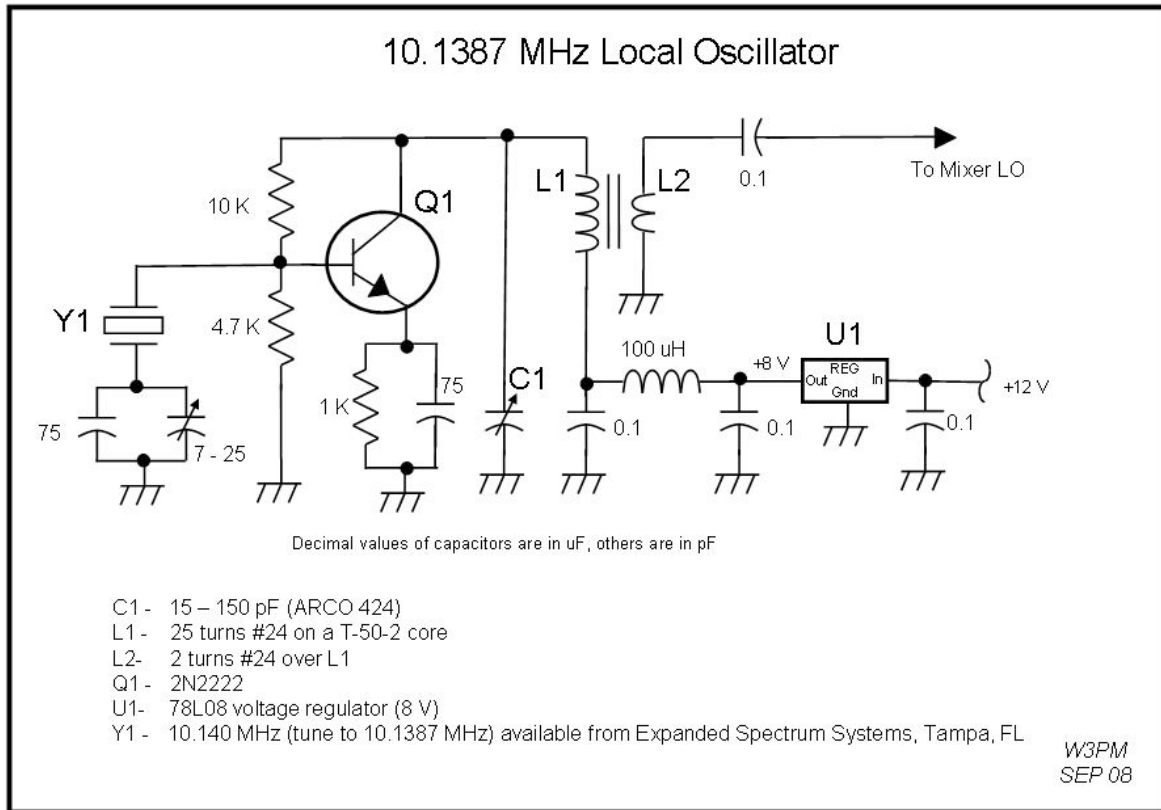

Fig. 2 - Local Oscillator Schematic

This Colpitts oscillator will supply approximately 7 milliwatts of output to drive the SBI-1 mixer. The local oscillator should be mounted in a separate shielded box away from heat sources or drafts. The transceiver requires a stable oscillator that is able to be adjusted within a few Hz of 10.138700 MHz.

### 10.1373 MHz NOTCH FILTER / MIXER:

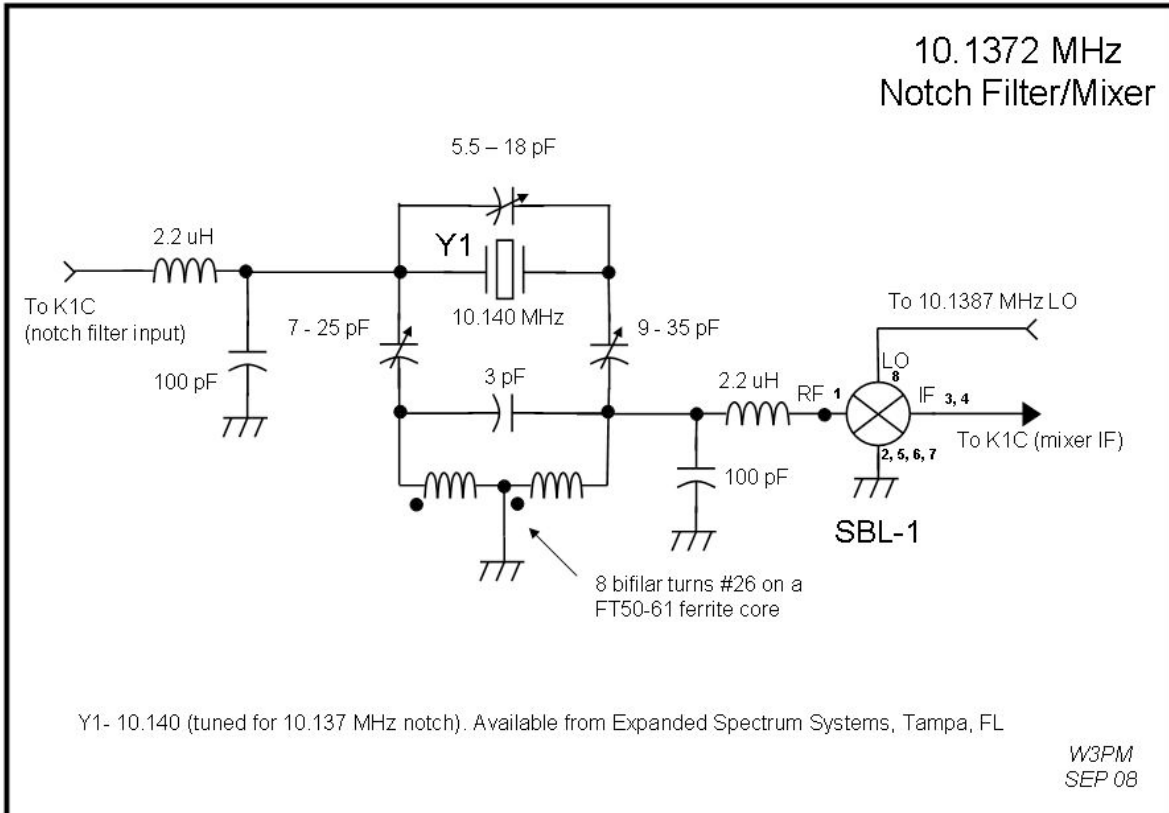

Fig. 3 - Notch Filter / Mixer Schematic

This is a modified version of a single crystal bandpass filter found in *Experimental Methods in RF Design* by Hayward, Campbell, and Larkin. The extra phasing capacitor allows the filter to be adjusted for a peak at the 10.1402 MHz upper sideband frequency and a deep null at the lower sideband frequency of 10.1372 MHz. The filter's response is shown in figure 4. The insertion loss at 10.1402 MHz is approximately 0.5 dB.

I used a SBL-1 for the mixer because one was readily available. A TUF-1 or TUF-3 package would probably be a better substitute.

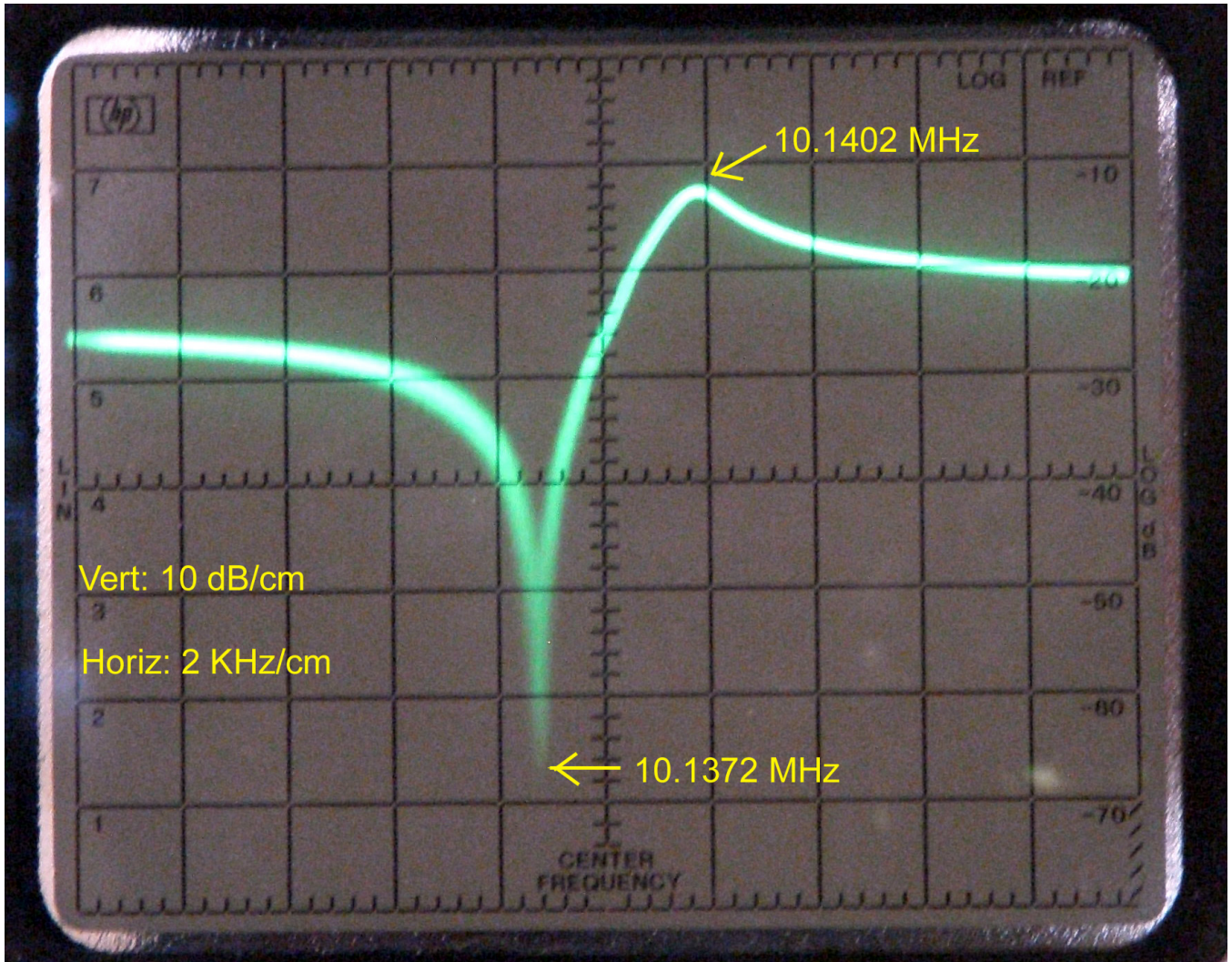

Fig. 4 - Notch Filter Response

**RECEIVER AF:**

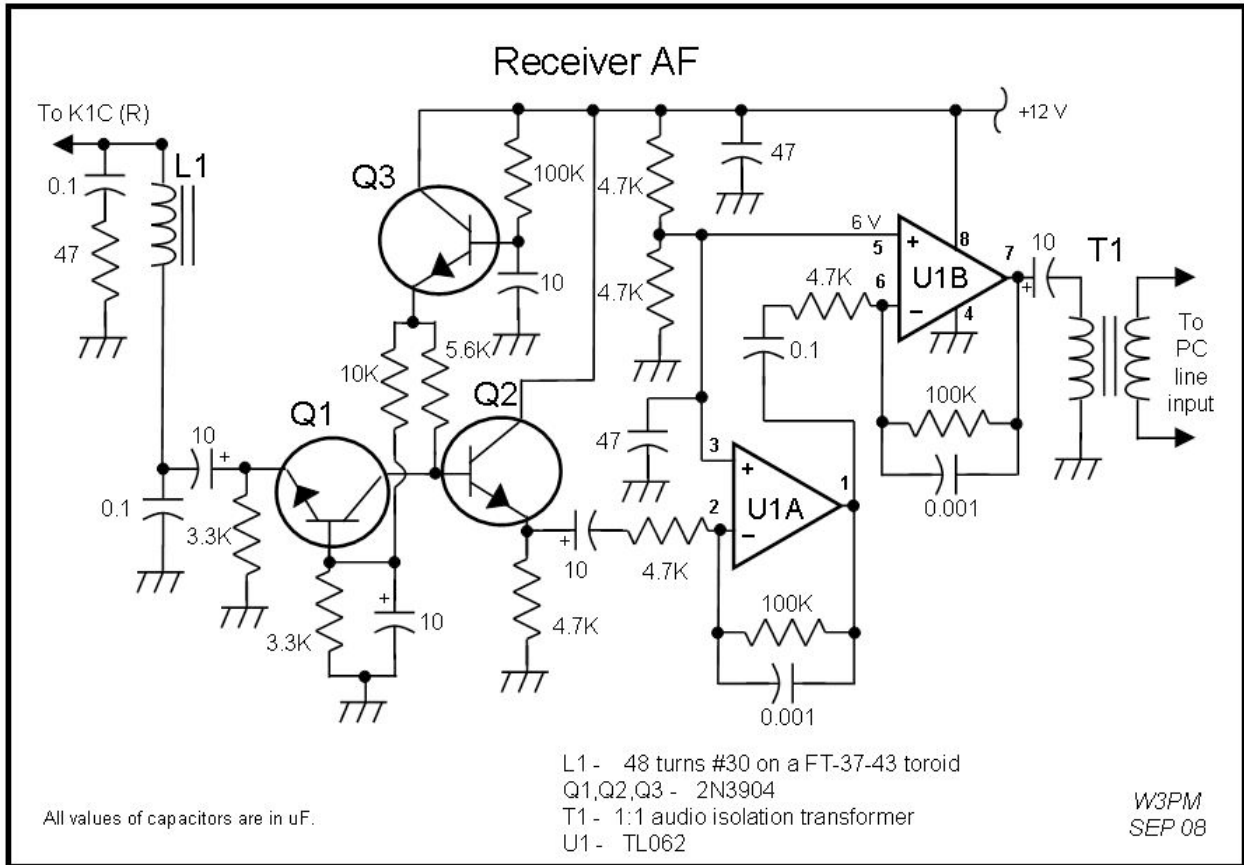

Fig. 5 - Receiver AF Schematic

This amplifier provides the audio gain for the low level 1400 – 1600 Hz. WSPR signals from the mixer IF to drive the soundcard line input for signal processing. The circuit is based upon the amplifier chain used in the Rick Campbell, KK7B binaural receiver circuit from March 1999 QST. To keep the design simple, I sacrificed some dynamic range by eliminating the diplexer KK7B used to terminate the mixer. Any low noise dual op-amp such as the NE5532 may be substituted for U1. A Radio Shack #273-1374 1:1 isolation transformer will work well for T1.

## TRANSMITTER AF:

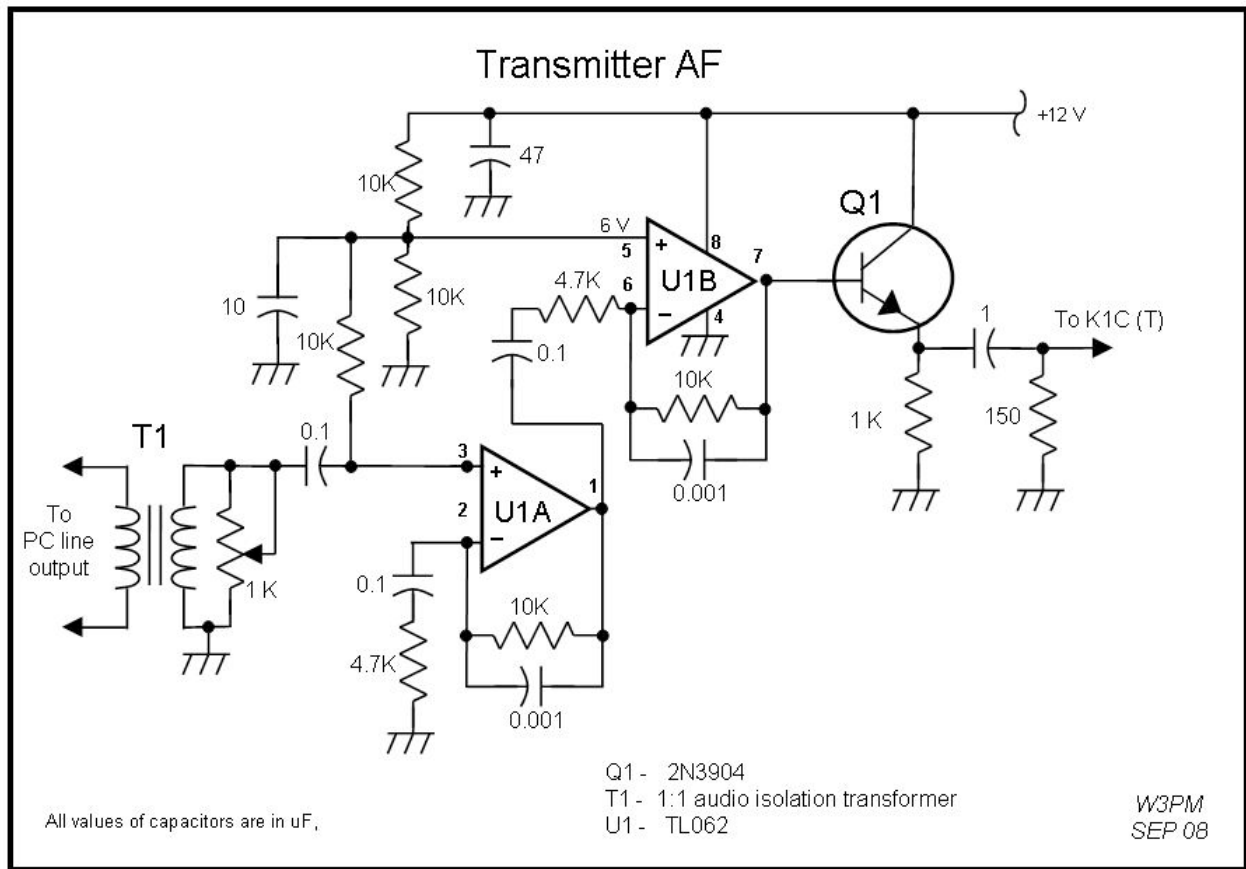

Fig. 6 - Transmitter AF Schematic

This amplifier provides the audio gain for the low level 1400 – 1600 Hz. transmit WSPR signal from the soundcard line output to drive the mixer IF port when in transmit mode. The circuit is based upon the amplifier chain used in the Rick Campbell, KK7B phasing exciter circuit from April 1993 QST. Any low noise dual op-amp such as the NE5532 may be substituted for U1. A Radio Shack #273-1374 1:1 isolation transformer will work well for T1.

**TRANSMITTER:**

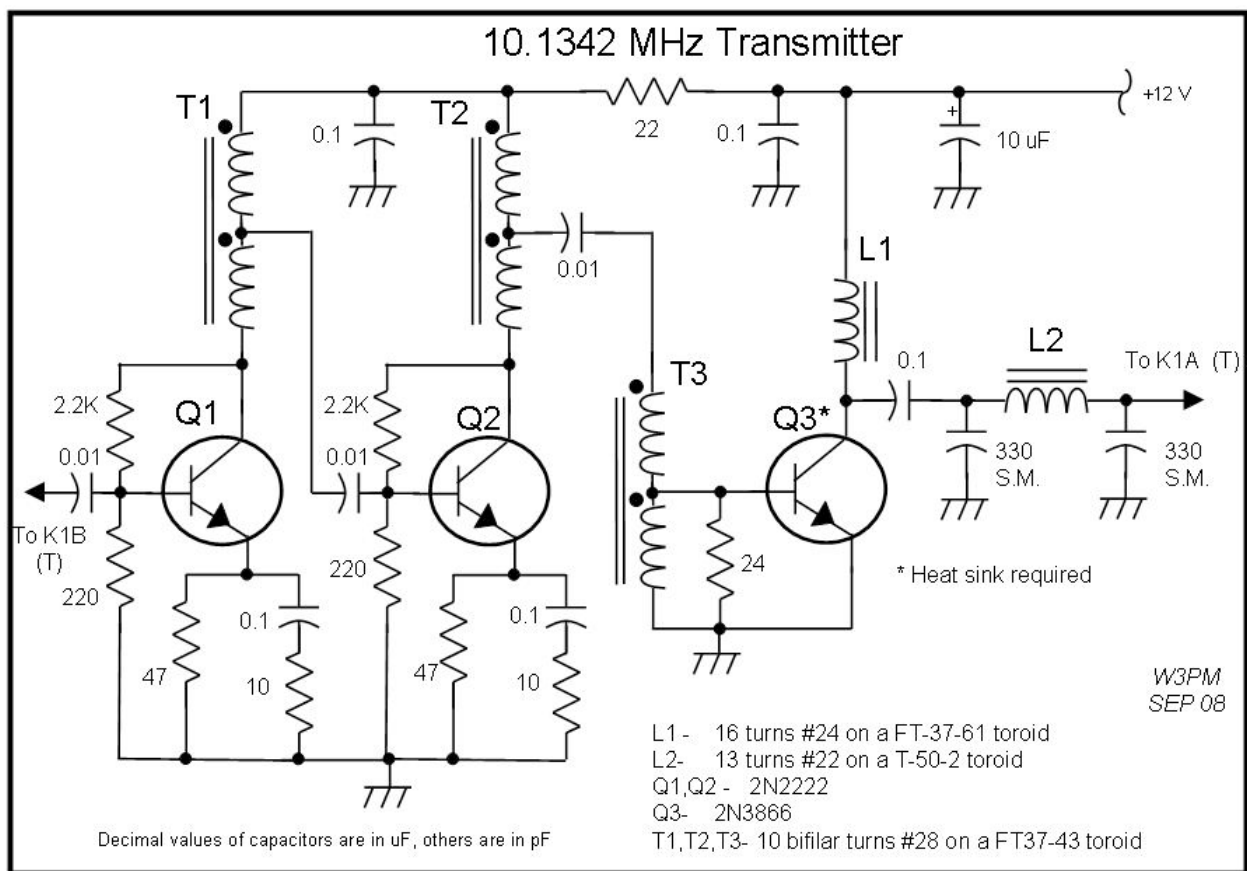

Fig. 7 - Transmitter Amplifier Chain Schematic

The three stage class C amplifier is a modified version of the transmitter circuit used in R. Hayward and W. Hayward's "The 'Ugly Weekender'" from QST, August 1981. Power output is varied by adjusting the soundcard's audio output. When adjusted for a power output of one watt, all harmonics are greater than 40 dB below the carrier as shown in figure 8. Spectral output purity will degrade if the transmitter's



power output is set below 0.5 watt or above 1.5 watts. Be sure to use a fairly large heat sink on Q3. The transmitter will transmit continuously at full power for almost two minutes during each transmit cycle.

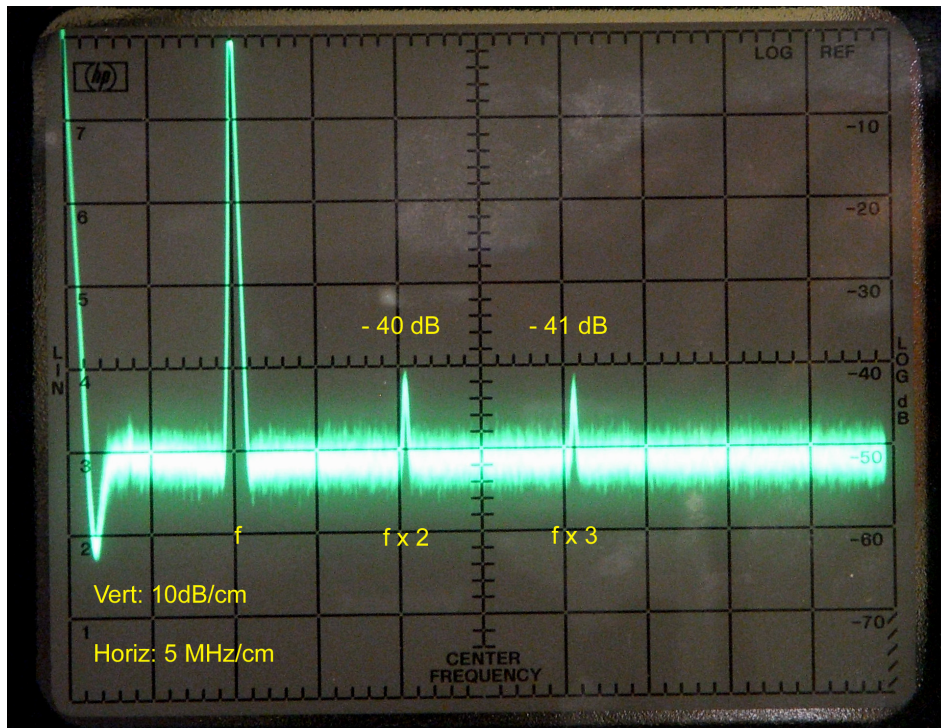

Fig. 8 - Transmitter Spectral Response

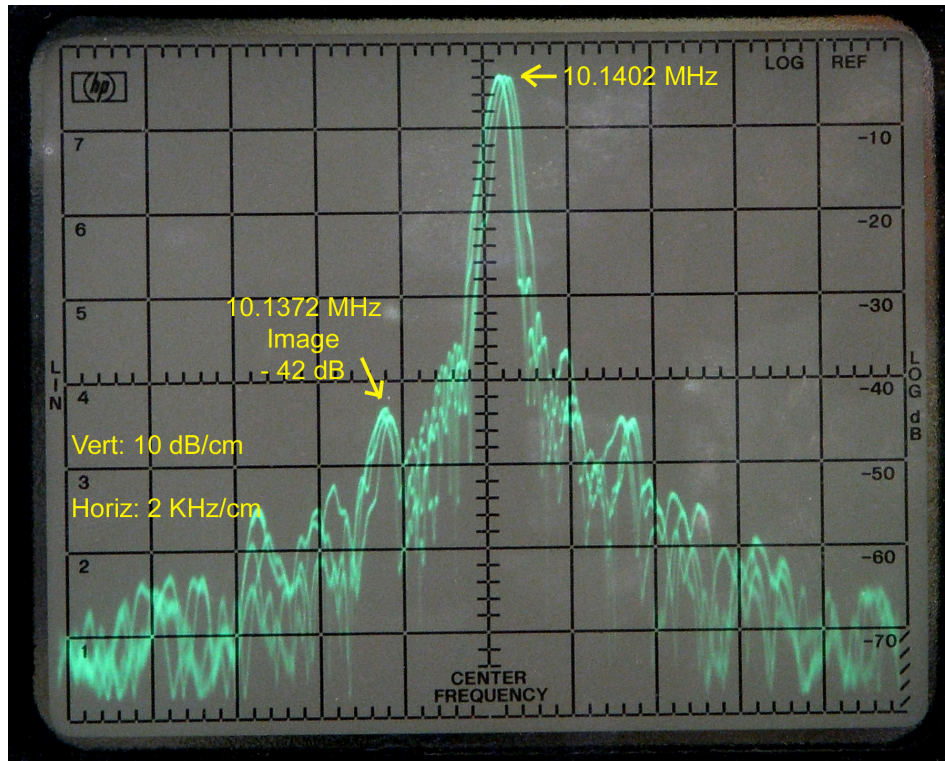

Fig. 9 - Transmitter Close-In Spectral Response

**TRANSMIT/RECEIVE RELAY:**

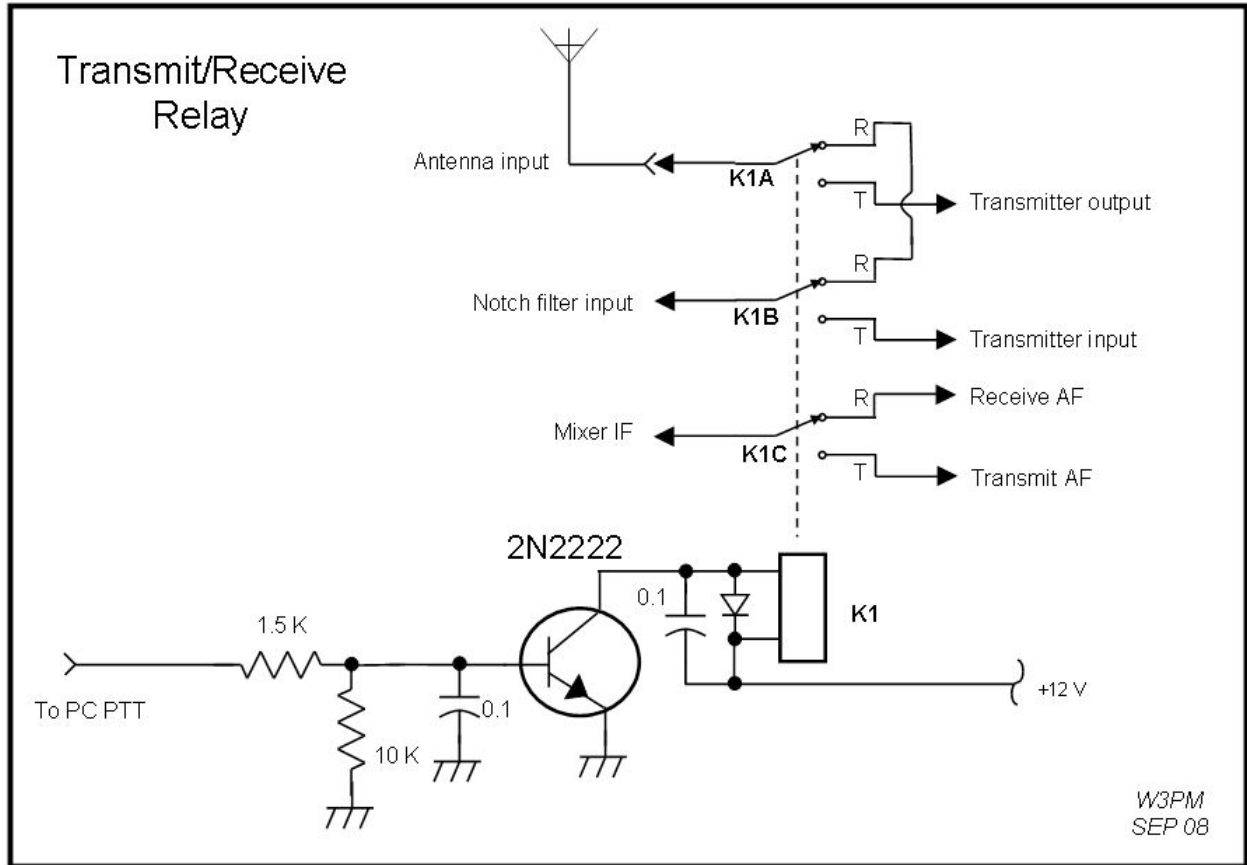

Fig. 10 – Transmit/Receive Relay

I used a surplus relay that I had in my junkbox. Two 12 VDC DPDT relays such as the Radio Shack #275-281 would serve as a good substitute. I did attempt to use electronic switching, but the circuitry began to rival that of the entire transceiver.

**ALIGNMENT USING TEST EQUIPMENT:**

If test equipment is available, it is a simple matter to test each module after it is built. A counter is used to adjust the local oscillator. Adjust C1 for maximum output and at the same time ensure proper startup upon re-application of power. After a stabilization period of about 15 minutes, adjust the oscillator to 10.138700 MHz using the 7 – 25 pF adjustable capacitor. If the oscillator cannot be adjusted to 10.138700 MHz, replace the 75 pF fixed capacitor with a lower value to increase the frequency or use a higher value to decrease the frequency.

Temporarily disconnect the mixer and connect a spectrum analyzer and tracking generator to the notch filter. Adjust the three variable capacitors in the notch filter for the response shown in Fig. 4. The three adjustments are interactive so the process may have to be repeated several times to ensure maximum LSB suppression. A signal generator with sufficient frequency accuracy and an oscilloscope may be substituted for the spectrum analyzer and tracking generator. Adjust for a null at 10.137200 MHz and a peak at 10.140200 MHz.

After final assembly, connect to a computer and use the WSPR program to ensure proper operation into a dummy load. Using a low power wattmeter or oscilloscope, adjust for one watt output using the WSPR program's "TX volume control". I set the "TX volume control" to mid-point and adjusted the 1K variable potentiometer on the TX AF module for one watt output. At this point the local oscillator may have to be slightly re-adjusted. Set the transmitter frequency to 10.140200 MHz with the WSPR program. Sample the transmitters output through a directional coupler or a small pick-up loop connected to the counter. If necessary, re-adjust the local oscillator if the displayed frequency is not within a few Hz of 10.40200 MHz. There will be some slight frequency wobble due to the nature of the continuous phase FSK transmission

#### **ALTERNATIVE ALIGNMENT:**

A QRSS viewer such as ARGO developed by Alberto, I2PHD could be used in conjunction with an accurate stable receiver to set the local oscillator. This program may be downloaded at: <http://digilander.libero.it/i2phd/argo/index.html>. Use a small pickup loop (or no antenna at all) at the receiver's input for the following tests. Set the receiver to USB and tune to 10.137000 MHz. The oscillator's frequency should be found near 1700 Hz on the ARGO display. Adjust C1 for maximum output and at the same time ensure proper startup upon re-application of power. After a stabilization period of about 15 minutes, adjust the oscillator to 1700 Hz (10.138700 MHz) on the ARGO display using the 7 – 25 pF adjustable capacitor. If the oscillator cannot be adjusted to 1700 Hz, replace the 75 pF fixed capacitor with a lower value to increase the frequency or use a higher value to decrease the frequency.

After final assembly, connect a temporary wire jumper from the notch filter input to the mixer's RF port. Use the WSPR program to ensure proper operation into a dummy load. Using a low power wattmeter or oscilloscope, adjust for one watt output using the WSPR program's "TX volume control". I set the "TX volume control" to mid-point and adjusted the 1K variable potentiometer on the TX AF module for one watt output.

Set the receiver to 10.138700 MHz USB. Set the transmitter frequency to 10.140200 MHz with the WSPR program. Observe the transmitted signal near 1500 Hz on the ARGO display. If necessary, re-adjust the local oscillator to within a few Hz of 1500 Hz (10.40200 MHz).

Remove the jumper wire from the notch filter. Set the receiver for LSB. Observe the image frequency at 1500 Hz (10.137200 MHz) while transmitting. Adjust the signal to minimum with the three variable notch filter capacitors. Set the receiver to USB and measure the amplitude of the 1500 Hz (10.140200 MHz) signal. If it is not approximately 40 dB stronger than the image re-adjust the capacitors. The three adjustments are interactive so the process may have to be repeated several times to ensure maximum LSB suppression.

### **PERFORMANCE:**

I compared the receiver's performance by using a Wilkerson power divider to simultaneously connect this transceiver and a FT-817 to my station antenna. I allowed both rigs to collect of-the-air receive reports for a period of four hours. I could find essentially no difference between the received signal-to-noise level reports. I use a vertical antenna in a suburban environment so the overall received noise level is probably higher than average at my location. If you live in a quiet RF environment you may want to consider using a preamplifier between K1A (R) and K1B (R) to lower the transceiver's noise figure.

The local oscillator takes a few minutes to reach its nominal frequency after a cold start. It slowly drifts upwards in frequency about 30 Hz in 15 minutes until it reaches 10.138700 MHz. After that it will very slowly drift about 12 Hz around nominal within a two hour period. WSPR drift rate reports are nearly always "0" after adequate warm-up. Greater stability could probably be achieved by using a crystal that is closer to the nominal frequency of 10.138700 MHz, but I am happy with the performance of this \$2.55 crystal.

This transceiver can usually be heard in operation most days on 30 meters. I may be contacted at "W3PM at AMSAT dot org" for any questions or comments.

**MODULE PHOTOS:**

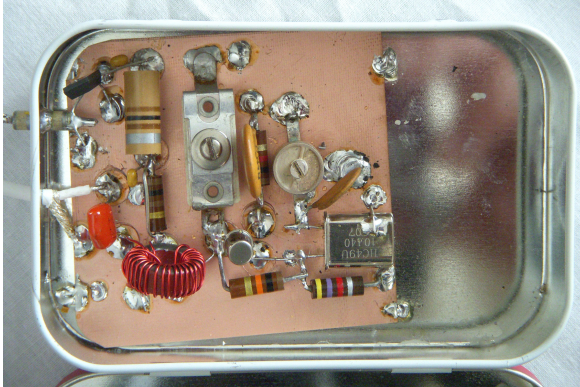

**Local Oscillator**

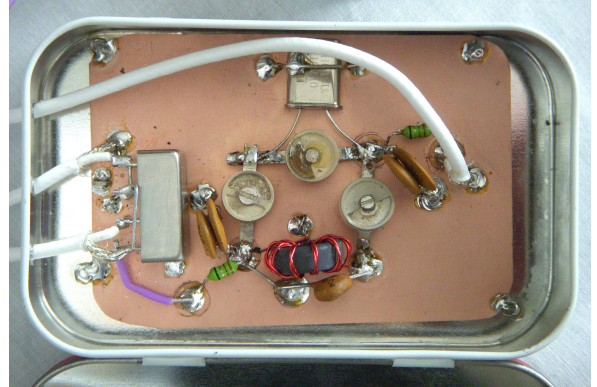

**Notch Filter / Mixer**



**Receiver AF**

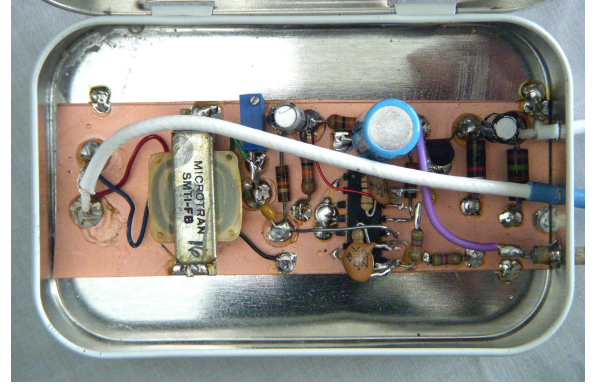

**Transmitter AF**

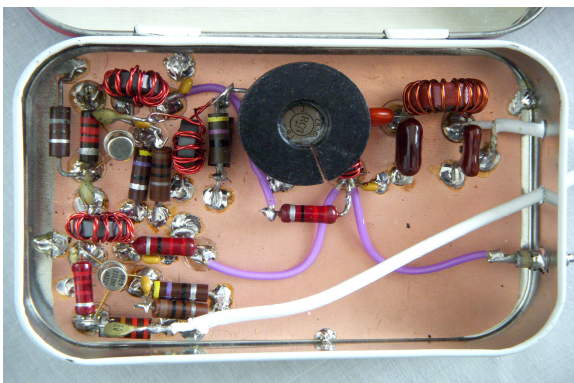

**Transmitter  
Transmit /  
Receive  
Relay**

