



偉詮電子股份有限公司
Weltrend Semiconductor, Inc.

WT7527
PC POWER SUPPLY SUPERVISOR
Data Sheet

Version 1.20

June 22, 2007

**The information in this document is subject to change without notice.
©Weltrend Semiconductor, Inc. All Rights Reserved.**

新竹市科學工業園區工業東九路24號2樓
2F, No. 24, Industry E. 9th RD., Science-Based Industrial Park, Hsin-Chu, Taiwan
TEL:886-3-5780241 FAX:886-3-5794278.5770419
Email:support@weltrend.com.tw

GENERAL DESCRIPTION

The WT7527 provides protection circuits, power good output (PGO), fault protection latch (FPOB), and a protection detector function (PSONB) control. It can minimize external components of switching power supply systems in personal computer.

The Over Voltage Detector (OVD) monitors VX, V33, V5, V12A and V12B input voltage level. The Under Voltage Detector (UVD) monitors V33, V5, V12A and V12B input voltage level. The Over Current Detector (OCD) monitor I33&V33, I5&V5, I12A&V12A and I12B&V12B input current sense. The pin VX provides an extra protection function. When OVD or UVD or OCD or VX detect the fault voltage level, the FPOB is latched HIGH and PGO go low. The latch can be reset by PSONB go HIGH. There is 4 ms delay time for PSONB turn off FPOB.

When OVD and UVD and OCD detect the right voltage level, the power good output (PGO) will be issue.

FEATURES

- The Over Voltage Detector (OVD) monitors VX, V33, V5, V12A and V12B input voltage.
- The Under Voltage Detector (UVD) monitors V33, V5, V12A and V12B input voltage.
- The Over Current Detector (OCD) monitors I33&V33, I5&V5, I12A&V12A and I12B&V12B input pins.
- The VX > 1.2V provide an extra protection.
- Both of the power good output (PGO) and fault protection latch (FPOB) are Open Drain Output.
- 75 / 600 ms time delay for UVD / OCD / VX .
- 300 ms time delay for PGO.
- 38 ms for PSONB input signal De-bounce.
- 14 us for OVD internal signal De-glitch.
- 60 us for UVD / VX internal signal De-glitch.
- 20 ms for OCD internal signal De-glitch.
- 73 us for PGI internal signal De-glitch.
- 4 ms for PSONB turn-off FPOB.

PIN ASSIGNMENT AND PACKAGE TYPE

Pin assignment

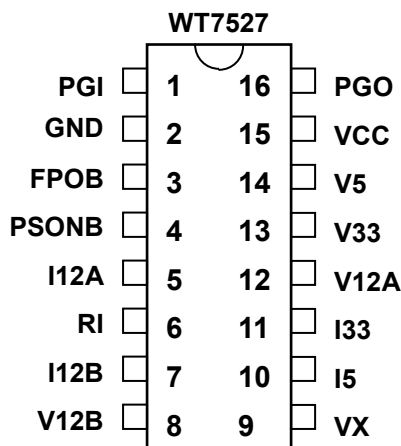

ORDERING INFORMATION

Part Number	Package Type	Note
WT7527–NN160–1D	16-Pin Plastic DIP, Pb-free	
WT7527–NN161–1D		
WT7527–SN160–1D	16-Pin Plastic SOP, Pb-free	
WT7527–SN161–1D		

PIN DESCRIPTION

Pin Name	I/O	Description
PGI	I	Power good input signal pin
GND	P	Ground
FPOB	O	Fault protection output pin, open drain output
PSONB	I	On/Off switch input
I12A	I	12VA over current protection sense input
RI	I	Current sense adjust input
I12B	I	12VB over current protection sense input
V12B	I	12VB over voltage & under voltage & over current sense input pin
VX	I	Extra protection sense input
I5	I	5V over current protection sense input
I33	I	3.3V over current protection sense input
V12A	I	12VA over voltage & under voltage & over current sense input pin
V33	I	3.3V over voltage & under voltage & over current sense input pin
V5	I	5V over voltage & under voltage & over current sense input pin
VCC	I	Power supply
PGO	O	Power good output signal pin, open drain output

BLOCK DIAGRAM

WT7527-160

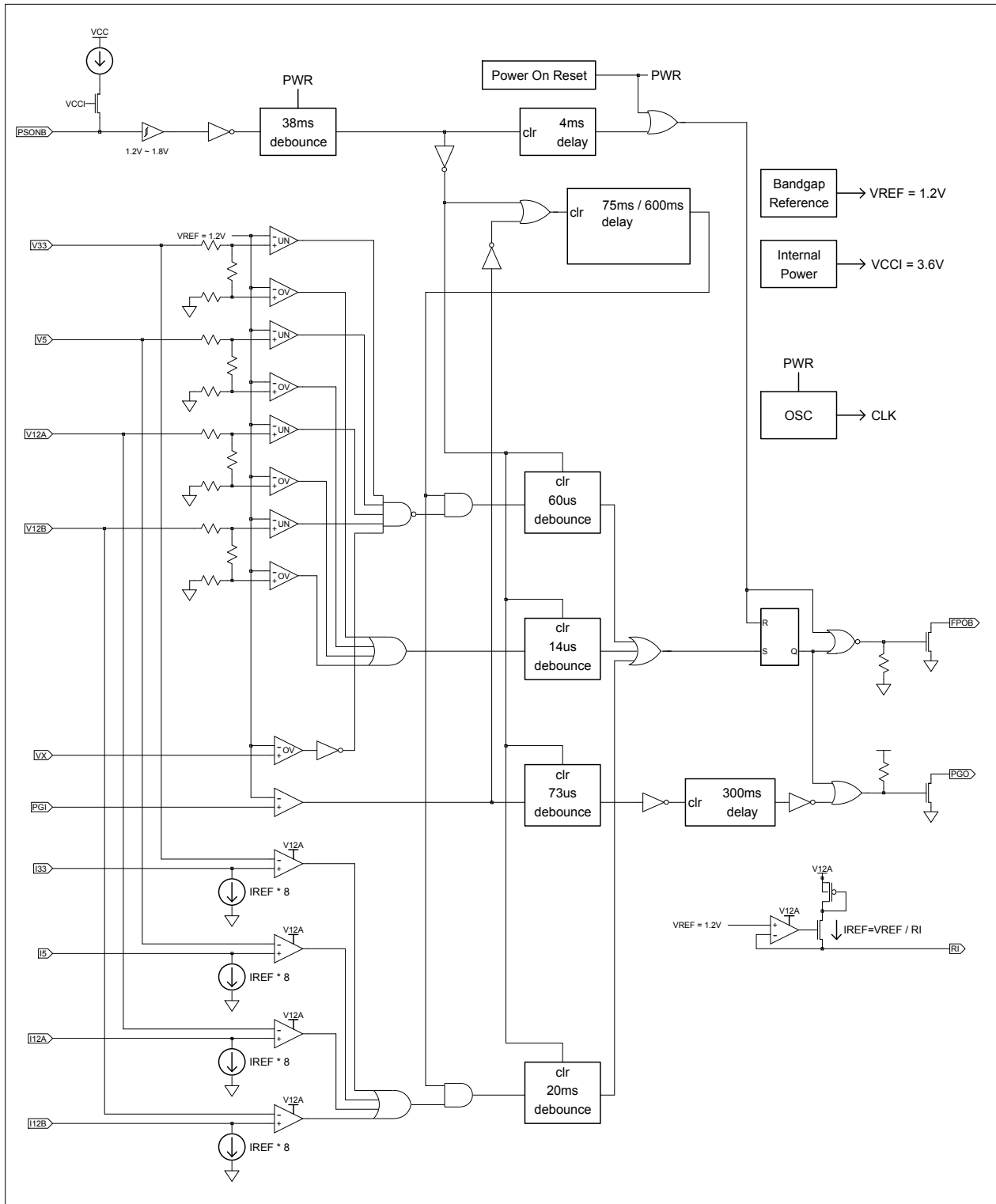

ABSOLUTE MAXIMUM RATINGS

Parameter		Min.	Max.	Unit
Supply voltage, VCC, V12A		-0.3	16	V
Input voltage	PGI, PSONB	-0.3	VCC + 0.3 (Max. 7V)	V
	V5, I5, V33, I33		V12A + 0.3 (Max. 7V)	V
	I12A, V12B, I12B		V12A + 0.3 (Max. 16V)	V
Output voltage	PGO	-0.3	VCC + 0.3 (Max. 7V)	V
	FPOB	-0.3	16	V
Operating temperature		-40	125	°C
Storage temperature		-55	150	°C

*Note: Stresses above those listed may cause permanent damage to the devices

RECOMMENDED OPERATING CONDITIONS

Parameter		Conditions	Min.	Typ.	Max.	Unit
Supply voltage, VCC			3.8	5	16	V
Input voltage	PGI, PSONB, V5, V33				7	V
	V12A, V12B				16	V
Output voltage	PGO				7	V
	FPOB				16	V
Output sink current	FPOB	0.3V			10	mA
	PGO	0.3V			10	mA
Output current for RI	RI		10		65	uA

ELECTRICAL CHARACTERISTICS, at Ta=25°C and V_{CC}=5V.
Over Voltage Detection

Parameter		Condition	Min.	Typ.	Max.	Unit
Over voltage threshold	V33		3.8	3.9	4.0	V
	V5		5.6	5.8	6.0	V
	V12AB		13.5	13.85	14.2	V
	VX	Use UVD timing	1.176	1.20	1.224	V
I _{LEAKAGE}	Leakage current (FPOB)	V(FPOB) = 5V	5			uA
V _{OL}	Low level output voltage (FPOB)	I _{sink} = 10mA			0.3	V

PGI and PGO

Parameter		Condition	Min.	Typ.	Max.	Unit
Under voltage threshold	V33		2.8	2.9	3.0	V
	V5		4.2	4.4	4.6	V
	V12AB		10.3	10.65	11.0	V
Input threshold voltage(PGI)			1.176	1.20	1.224	V
I _{LEAKAGE}	Leakage current(PGO)	PGO = 5V	5			uA
V _{OL}	Low level output voltage(PGO)	I _{sink} = 10mA			0.3	V
Offset Voltage of OCP comparators			-6		6	mV

PSONB

Parameter		Condition	Min.	Typ.	Max.	Unit
Input pull-up current		PSONB= 0V		150		uA
High-level input voltage			1.8			V
Low-level input voltage					1.2	V

TOTAL DEVICE

Parameter	Condition	Min.	Typ.	Max.	Unit
I _{cc} Supply current	PSONB= 5V			1	mA
V _{cc} operation start up voltage		3.2	3.4	3.6	V
V _{cc} under lockout voltage		2.8	3.0	3.2	V

SWITCHING CHARACTERISTICS, at Ta=-40°C~125°C

Parameter	Condition	Min.	Typ.	Max.	Unit	
PGI to PGO Delay Time	Td1	200	300	400	mS	
	Td2	49	75	100	mS	
Short circuit Delay Time	Td2-1	For 160	392	600	800	mS
		For 161	∞			mS
PGO to FPOB Delay Time	Td3	2	4	6	mS	
Under Voltage Delay Time	Td4	40	60	81	μS	
Over Current Delay Time	Td5	13	20	27	mS	
Over Voltage Delay Time	Td6	9	14	19	uS	
VX Delay Time	Td7	40	60	81	μS	
PSONB De-bounce Time	Tb1	24	38	52	mS	
PGI De-bounce Time	Tb2	47	73	100	μS	

APPLICATION CIRCUIT

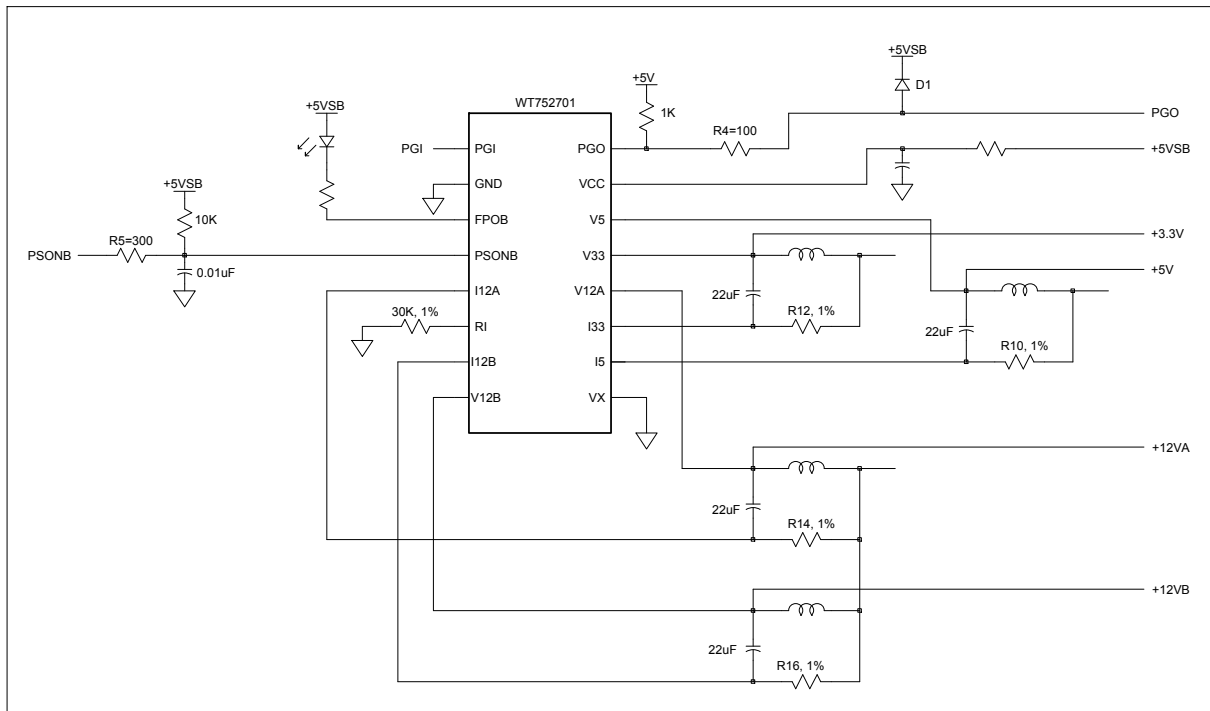

NOTE1 : The series resistor R5 at PSONB can not be omitted. (R5 = 300Ω is suggested)

NOTE2 : The series resistor R4 = 100Ω and diode D1 at PGO is suggested.

APPLICATION NOTE

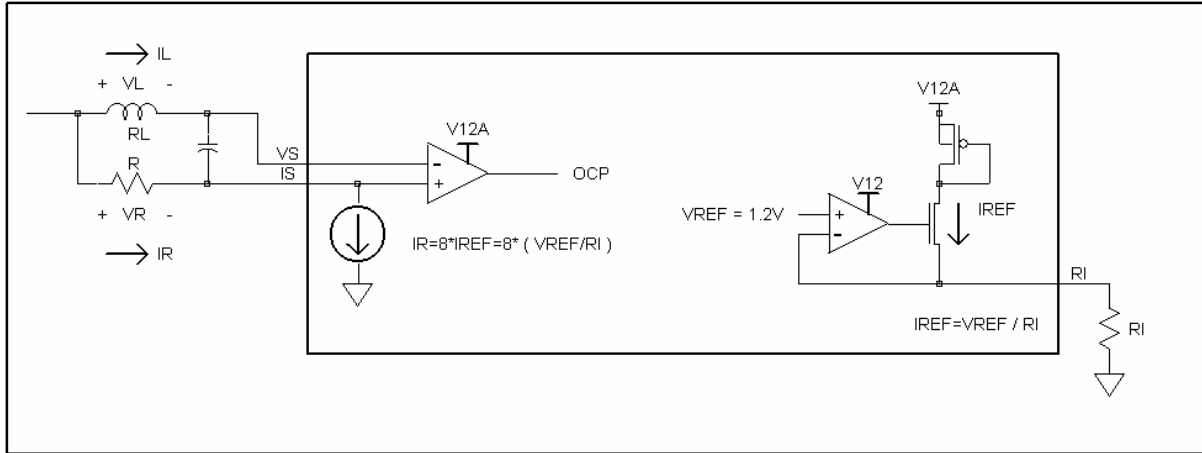

When the load current increased, the voltage (VL) cross the inductor is increased. And when inductor voltage exceeds the resistor voltage (VR), the OCP is active.

Sometimes power-on or load dynamics will cause false output of over-current detection. It can be solved by connecting a capacitor between VS pin and IS pin. In typical case, $C \geq 0.47\mu F$ is suggested.

OCP point can be calculated by the following equation:

Let $VR = VL$

$$R \times IR = RL \times IL$$

$$\therefore IR = 8 \times IREF = 8 \times \frac{VREF}{RI}$$

$$\therefore R = \frac{RL \times IL}{8 \times \frac{VREF}{RI}}$$

For example :

Assume $RI=30K\Omega$, $RL=5m\Omega$, OCP $IL=20A$.

$$\begin{aligned} \text{Sol : } R &= (IL * RL) / (8 * IREF) \\ &= (20A * 5m\Omega) / \{ 8 * (1.2V / 30K\Omega) \} \\ &= 312.5\Omega \end{aligned}$$

APPLICATION TIMMING

1.) PGI (UNDER_VOLTAGE) :

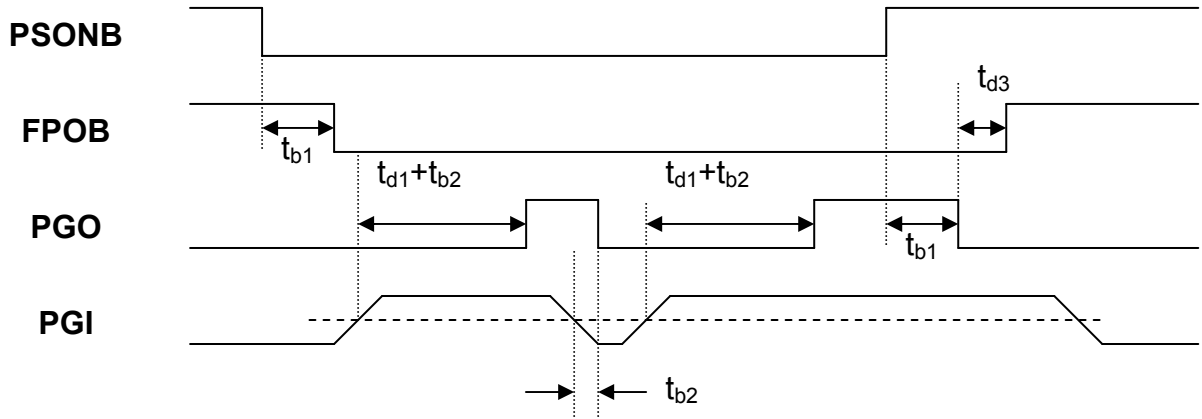

2.) V33, V5, V12 (UNDER_VOLTAGE) or I33, I5, I12 (OVER_CURRENT) or VX (OVER_VOLTAGE) :

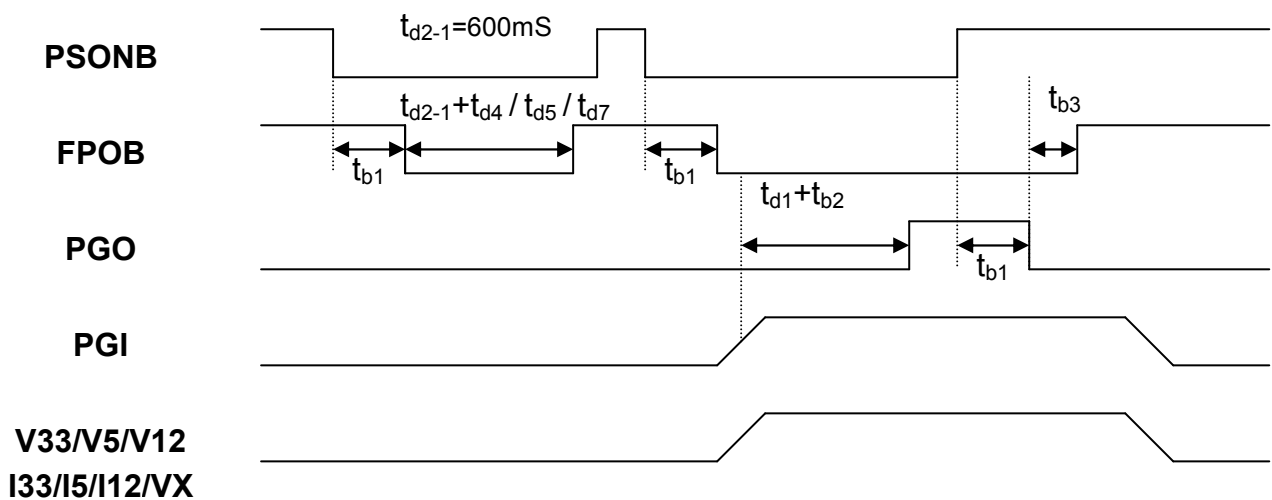
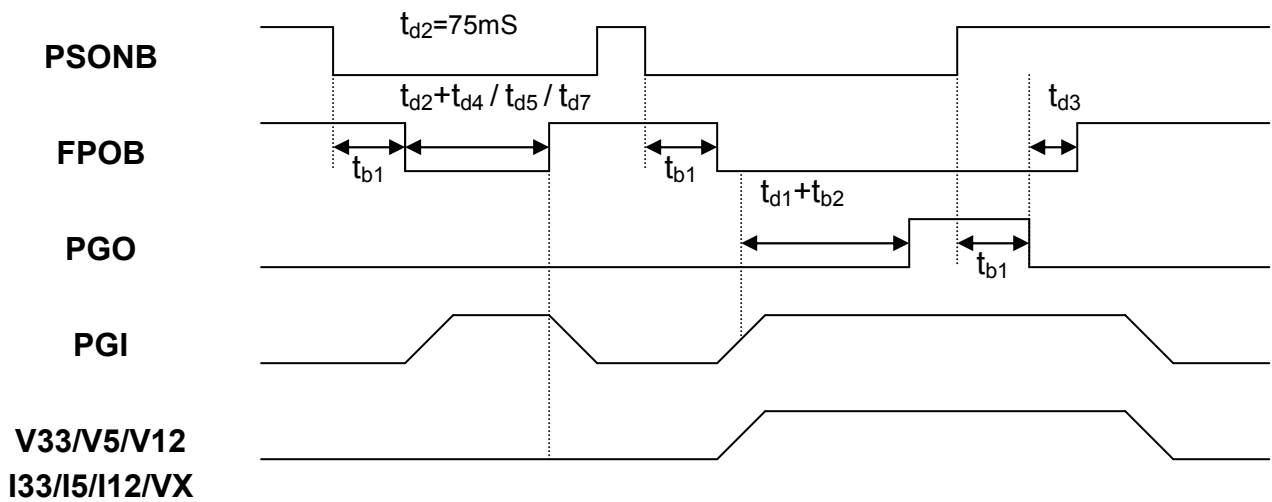
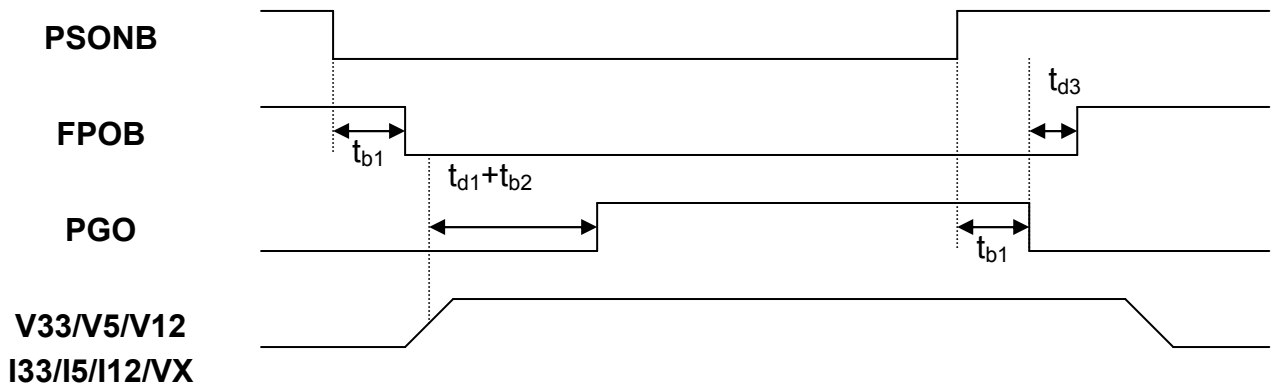

3.) V33, V5, V12 (OVER_VOLTAGE) :

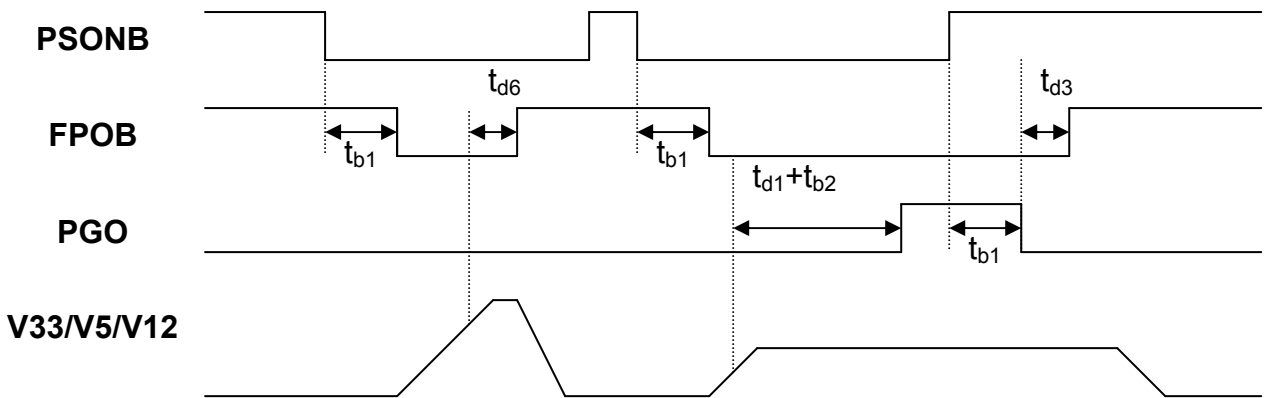
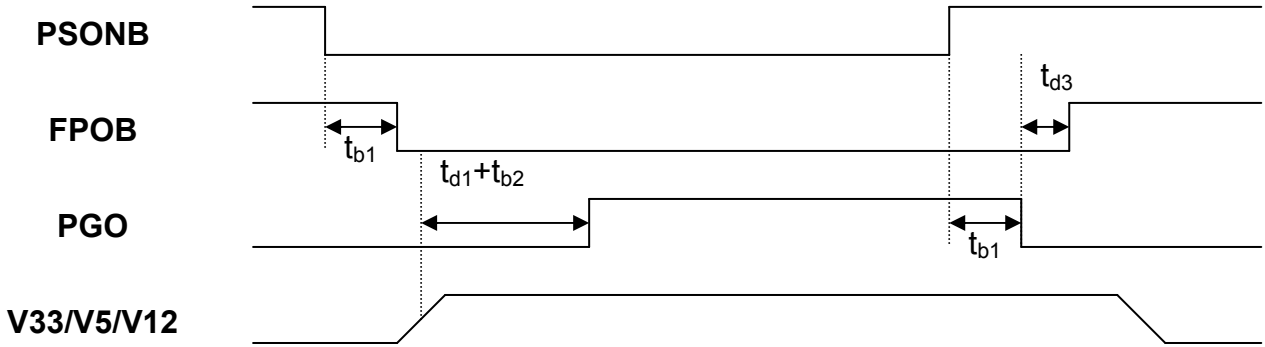

MECHANICAL INFORMATION

PLASTIC DUAL-IN-LINE PACKAGE

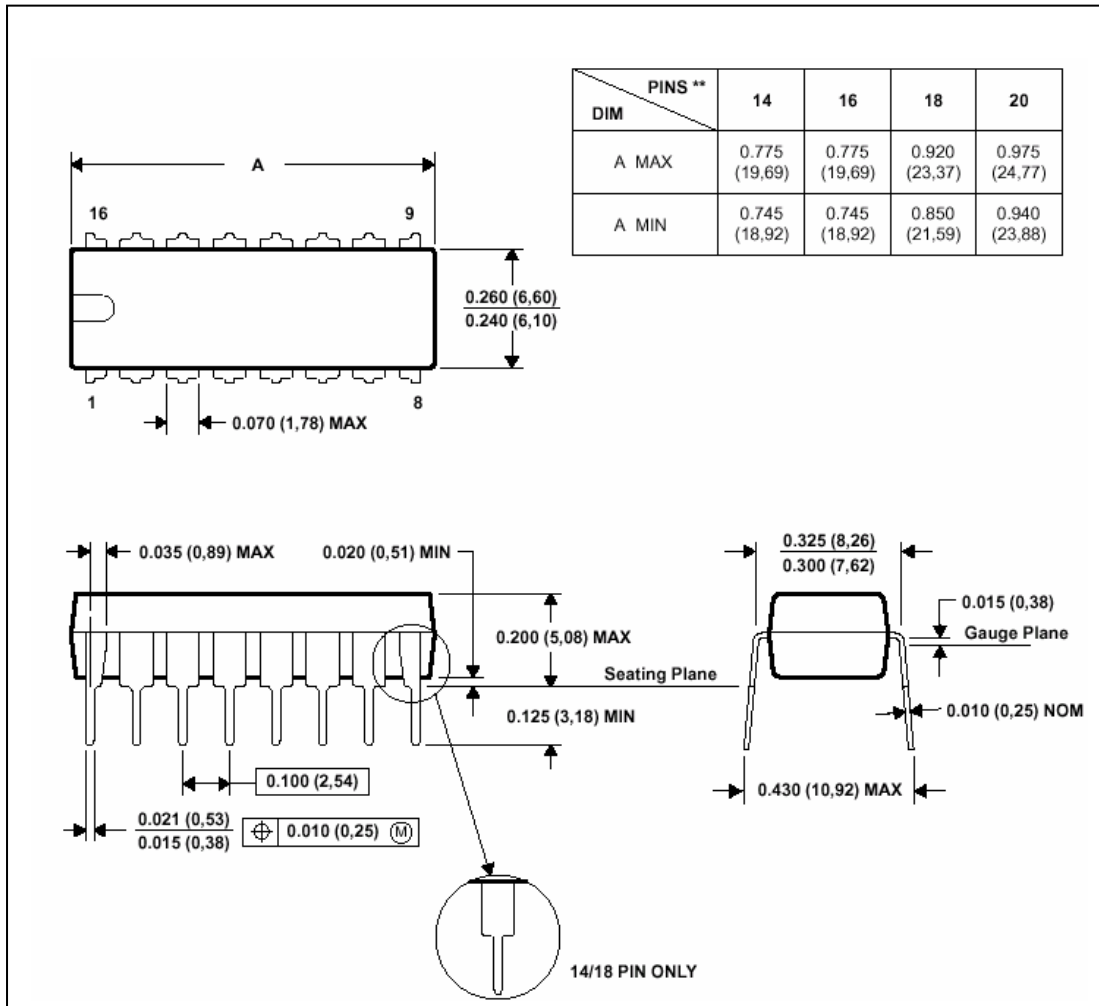

NOTE 1 : All linear dimensions are in inches (millimeters) .

NOTE 2 : This drawing is subject to change without notice.

NOTE 3 : Falls within JEDEC MS-001

PLASTIC SMALL-OUTLINE PACKAGE

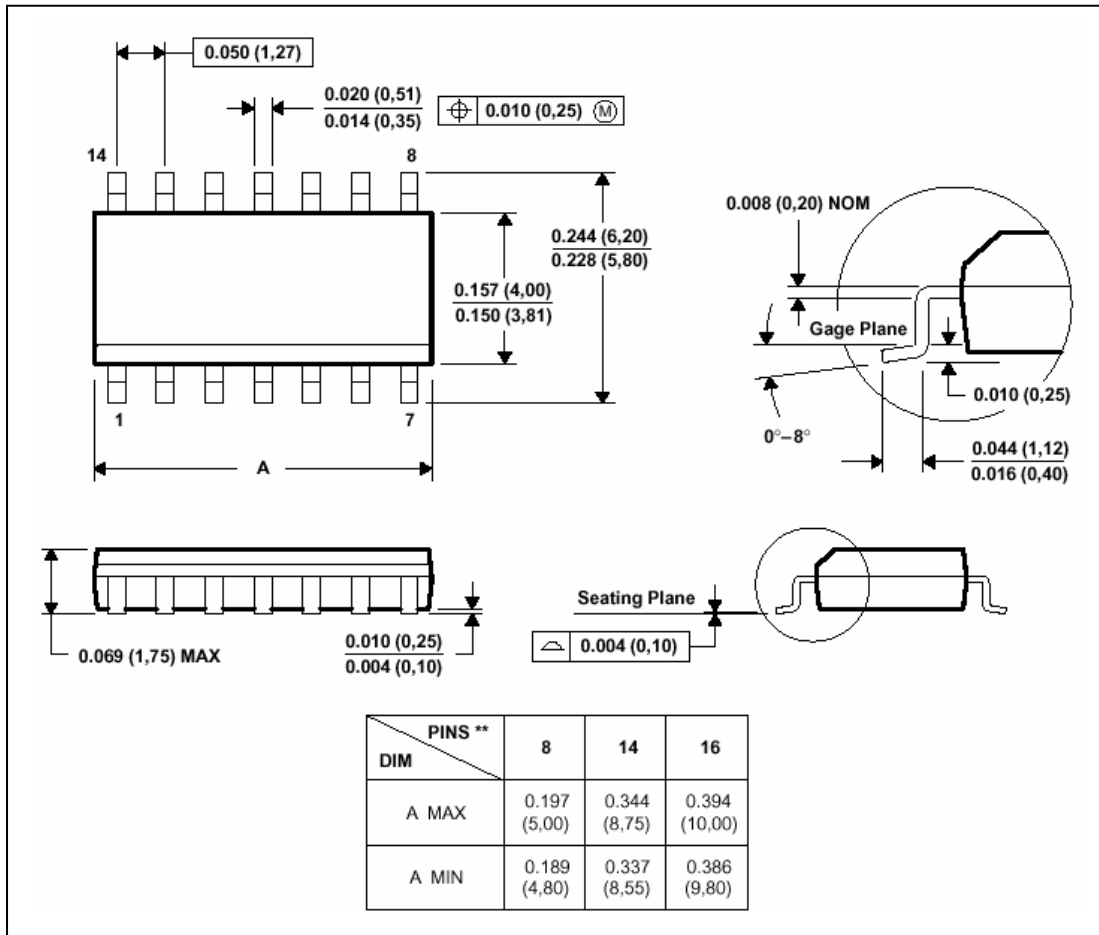

NOTE 1 : All linear dimensions are in inches (millimeters) .

NOTE 2 : This drawing is subject to change without notice.

NOTE 3 : Falls within JEDEC MS-012

www.s-manuals.com