



THE MINIMED
Paradigm[®]
INSULIN PUMP

User Guide



Paradigm[®]
515 and 715 Insulin Pumps
User Guide

©2008 Medtronic MiniMed, Inc. All rights reserved.

This product is covered by U.S. Patent Nos. 6,551,276; 6,554,798; 6,872,200; 6,936,029; 6,979,326; 6,997,920 and 7,025,743. Other U.S. and/or foreign patents may be pending.

Bolus Wizard[®], Dual Wave[®], Guardian[®], Guardian RT[®], Paradigm[®], Paradigm Link[®], Quick-serter[®], Quick-set[®], Sof-set[®], and Square Wave[®] are registered trademarks of Medtronic MiniMed, Inc.

CareLink[™] Personal and Easy Bolus[™] are trademarks of Medtronic MiniMed, Inc.

Energizer[®] is a registered trademark of Eveready Battery Company.

Glucagon Emergency Kit[®] is a registered trademark of Eli Lilly and Company.



Medtronic



Medtronic MiniMed
18000 Devonshire Street
Northridge, CA 91325
USA
800 646 4633
818 576 5555
www.medtronicdiabetes.com

R_x Only



6025020-018_b

REF MMT-515 MMT-715

Important Safety Information

Regarding Your Paradigm Insulin Infusion Pump

(includes all models)

Avoid Immersing Your Pump In Water

The pump was tested and met requirements for IPX7 at time of manufacture. For more information about IPX7, see the *Glossary on page 165*. Be aware that drops and bumps that occur over time will affect the integrity of the pump case and make it more vulnerable to damage from water. Lotions, sunscreens and insect repellent can also damage the pump case. It is not known how much water is needed to damage your pump. **You should avoid getting your pump wet. To shower, bathe, swim, or participate in water activities, always disconnect from your pump and reconnect after you are out of the water.**

If you inadvertently submerge your pump in water, dry the pump quickly using a soft, clean towel and verify that it is working properly by selecting **Selftest** from the pump's Utilities Menu. If you believe that water has entered your pump or you observe any other possible pump malfunction, please check your blood glucose, treat high blood glucose (if necessary) with an injection and contact our 24 Hour HelpLine at 1 800 646 4633 for further assistance. Symptoms of high blood glucose include fatigue, excessive thirst and nausea. Always contact your healthcare professional if you experience excessively high or low blood glucose levels, or if you have any questions about your care.

Electrostatic Discharge

Although your Paradigm pump is designed to be unaffected by typical levels of electrostatic discharge (ESD), very high levels of ESD can result in a reset of the pump's software with an associated pump error alarm. In most cases, exposure to high levels of ESD will trigger the pump's A-13 alarm although, under certain circumstances, high level ESD exposure can cause A-44, Bolus Stopped or Max Delivery alarms. High levels of ESD are more likely in situations where the relative humidity is very low, such as inside a heated building during the winter in areas where it is cold outside.

If your pump experiences an A-13 or other error alarm, press the ESC and ACT buttons to clear the alarm. If you are unable to clear the alarm by pressing ESC and ACT, you may need to remove and replace the pump's battery to clear the alarm. After clearing the alarm, you should always verify that your pump is set to the correct date and time and that all other settings (basal rate, max basal and bolus limits, etc.) are programmed to the desired values, since the software reset could erase your previously programmed settings. Please see the Alarms and Alerts section of this User Guide for more details regarding what to do if your pump displays an error alarm or other alert message.

Please contact our 24 Hour HelpLine at 1-800-MINIMED (1-800-646-4633) to report any error alarms or other problems that occur with your pump.

Contents

Chapter 1: Introduction	1
Assistance	1
Emergency kit	2
Consumables	2
Accessories	3
How to wear your pump	3
How to use this guide	4
User safety	5
Indications	5
Pump	5
Contraindications	5
Warnings	5
Pump	5
Reservoir and infusion sets	5
Tubing Connector	6
Magnetic fields	6
X-rays, MRIs and CT scans	7
Precautions	7
Avoid extreme temperatures	7
Infusion sets and sites	7
Notice	7
Insulin pump and RF accessories	7
RF interference from other devices	8
Chapter 2: Introduction to pump therapy	11
Theory of insulin pump therapy	11
Understanding pump therapy	12
Basal rate	12

Meal bolus	12
Gram counting	12
Exchange counting	12
BG targets	12
Insulin sensitivity	13
Active Insulin	13
Blood glucose and A1C testing	13
BG testing	13
A1C	13
Low blood glucose (hypoglycemia)	15
Hypoglycemia protocol: the rule of 15	16
High blood glucose (hyperglycemia)	16
Hyperglycemia protocol	17
Diabetes ketoacidosis (DKA)	17
Preventing DKA	17
Sick day management	18
Sick day protocol	18
Sick day supplies	19
Nutrition	19
Carbohydrate counting	20
Carbohydrate gram counting	20
Carbohydrate exchange system	20
Reading a food label	21
Fat and blood glucose	22
Protein and blood glucose	22
Other things that affect blood glucose	23
Healthy eating habits	23
Exercise	23
Chapter 3: The basics	25
Your pump	25
Install battery	26
Pump buttons	28
The pump screen	29
HOME screen	29
Screen icons	30
Battery	30

Time display	30
Reservoir volume	30
Alert and alarm icons	31
Scroll bar	31
Screen backlight	31
Beep/vibrate	31
Operating modes	31
Normal mode	32
Special mode	32
Attention mode	32
Menus	33
MAIN MENU	33
BOLUS MENU	33
SUSPEND	33
BASAL MENU	34
PRIME MENU	34
UTILITIES MENU	34
STATUS screen	34
If you remove your pump	35
Chapter 4: Basic programming	37
Setting the time and date	37
Selecting the language	39
Bolus	40
Setting the Normal Bolus	40
Review your bolus deliveries	44
Bolus details	46
Maximum bolus limit	47
BG reminder	47
Basal	48
Start and stop times	48
Your basal settings	49
Basal programming and delivery	50
Current basal delivery	51
Daily basal rate(s)	51
Setting the Max basal rate	52
Stopping your pump	53

Resume pump delivery	54
Chapter 5: Starting on insulin	57
Prepare your pump for use	57
Filling the reservoir	58
Changing your infusion set	61
Removing the reservoir	61
Rewinding your pump	62
Inserting the reservoir in your pump	62
Manual prime	64
Inserting the infusion set	65
Quick-set infusion set (with Quick-serter®)	67
Fixed prime	69
Prime history	69
Disconnecting Quick-set	70
Reconnecting Quick-set	71
Record keeping for diabetes management	71
Determining your pump settings	72
Chapter 6: Using the Bolus Wizard feature	73
What is it?	73
Carbohydrate counting	73
Your blood glucose reading	73
Your personal Bolus Wizard feature settings	74
How the Bolus Wizard feature works	77
Bolus Wizard warnings	77
High or low blood glucose levels	77
About maximum delivery	77
How to program the Bolus Wizard feature	78
Turning on the Bolus Wizard feature	78
Selecting the Carb units	78
Setting the Carb/Exch ratios	79
Setting the BG units	79
Insulin sensitivity	80
Setting the BG targets	81
About active insulin	82
Active insulin time	83

Review your Bolus Wizard feature settings	83
Meter option	83
Meter rules	84
Add, delete, review meter IDs	85
Normal bolus using Bolus Wizard feature	85
Bolus Wizard feature examples	87
Chapter 7: Optimizing pump therapy	91
Square Wave and Dual Wave bolus	91
Turning on the Dual Wave/Square Wave option	92
Square Wave or Dual Wave bolus without Bolus Wizard feature	92
Using the Bolus Wizard feature for a Square Wave or Dual Wave bolus	95
Easy bolus	97
Easy bolus setup	97
Step value setup	98
Delivering Easy Bolus	98
Basal patterns	100
Turning on the patterns	100
Programming a pattern	101
Select a pattern	102
Temp basal rates	103
How does temp basal work?	103
Temp basal types	104
Insulin rate (U/H)	104
Percent of basal	105
Chapter 8: Utilities	111
Alarm review	111
Setting your alert type	111
Auto-off	112
LOW RESV WARNING (Low reservoir warning)	112
Review daily insulin totals	113
Pump data management	114
Meter blood glucose information	114
Personal reminders	117
Alarm clock	117
Remote control option	117

Turn on remote control option	118
Add, delete, review remote control IDs	118
Block feature	119
Turning block on	119
Lock keypad feature	120
Locking the keypad	120
Unlocking the keypad	120
Selftest	120
User settings	121
Saving the settings	122
Restoring the settings	122
Clearing the settings	123
History	123
Chapter 9: Therapy software	125
CareLink Personal™	125
Reports	125
Logbook	126
Chapter 10: Insulin pump therapy follow-up	127
Recommended follow-up	127
Everyday	127
Every month	127
Every 3 months	127
Laboratory tests	128
Every visit	128
Annually	128
Chapter 11: Troubleshooting and alarms	129
My pump has a NO DELIVERY alarm	129
What happens if I leave the pump battery out too long?	130
Why doesn't my pump battery last very long?	130
What is a CHECK SETTINGS alarm?	131
My screen appears distorted	131
I cannot get out of the priming loop	131
The pump is asking me to rewind	132
My bolus stopped	132

My pump buttons are not acting right during a bolus	132
My pump will not display my blood glucose reading from my meter	132
I dropped my pump	133
I submerged my pump in water	133
I cannot get to the User Settings screen	133
Alert conditions	134
What to do	135
LOW RESERVOIR ALERT	135
LOW BATTERY ALERT	135
Alarms	135
What to do	136
Alarm conditions	137
A (ALARM)	137
AUTO OFF	137
BATT OUT LIMIT	137
BOLUS STOPPED	137
BUTTON ERROR	137
CHECK SETTINGS	137
E (ERROR)	138
EMPTY RESERVOIR	138
FAILED BATT TEST	138
MAX DELIVERY	139
MOTOR ERROR	139
NO DELIVERY	139
NO RESERVOIR	139
OFF NO POWER	139
RESET	139
WEAK BATTERY	139
Chapter 12: Pump maintenance	141
Battery	141
Storage	142
Cleaning your pump	142
Chapter 13: Pump specifications	143
Alarms and error messages	143
Alarm history	143

Audio frequency	143
Backlight	143
Basal	143
BG target	144
Bolus delivery	144
Bolus history	144
Bolus units	144
Bolus Wizard feature	144
Carb ratios	145
Carb units	145
Daily totals	145
Default screen	145
Delivery accuracy	146
Pump motor	147
Dual Wave bolus	147
Easy bolus	147
Infusion pressure	147
Insulin sensitivity	147
Low resv (reservoir) warning	148
Meter value	148
Normal bolus	148
Occlusion detection	148
Percent temp basal	149
Power supply	149
Prime function	149
Prime history	149
Program safety checks	149
Pump size	149
Pump weight	149
Remote control	150
Reservoir	150
Square Wave bolus	150
Temporary (temp) basal rate	150
Time and date screen	150
Environmental conditions	150
Status screen	151
Bolus Wizard feature specifications	152

Bolus Wizard feature examples	155
Insulin delivery default settings	158
Bolus Wizard feature default settings	160
Icon table	161
Warranty	163
Glossary	165
Index	173

Introduction

Thank you for choosing Medtronic Diabetes (legally known as Medtronic MiniMed, Inc.) as your partner in helping you gain better control of your diabetes. Whether you are beginning pump therapy for the first time or upgrading from a previous model, we believe that the combination of state-of-the-art technology and the simple, menu-driven programming of the pump will provide many benefits.

This user guide is designed to help you to understand pump therapy and the operation of your Medtronic MiniMed Paradigm® pump. We strongly recommend that you work closely with your healthcare professional for a safe and complete pump start.

Assistance

Medtronic Diabetes provides a 24 Hour HelpLine for assistance. The HelpLine is staffed with technicians who are trained in the set-up and operation of the pump and are able to answer pump-related questions. When calling the HelpLine or your local Medtronic Diabetes office, please have your pump and serial number available. The phone number for the 24 Hour HelpLine is also on the back of your pump.

Department	Telephone number
24 Hour HelpLine (calls within the United States)	800.646.4633 (800.MiniMed)
24 Hour HelpLine (calls outside the United States)	+1.818.576.5555
Web site	www.medtronicdiabetes.com

Emergency kit

Keep an emergency kit with you at all times to make sure that you always have necessary supplies. Inform a family member, co-worker, and/or friend where this emergency kit is kept. Please refer to the *User safety* section in this chapter for more information on pump safety. Your emergency kit should include these items:

- Fast-acting glucose tablets
- Blood glucose monitoring supplies
- Urine ketone monitoring supplies
- Extra Paradigm® compatible infusion set and Paradigm reservoir
- Insulin syringe and fast-acting insulin (with dosage instructions from your healthcare professional)
- Paradigm Quick Reference Card
- Dressing and adhesive
- Glucagon Emergency Kit®
- Extra AAA alkaline batteries (Energizer® brand is recommended)

CAUTION: If you give yourself insulin by using a syringe, the Bolus Wizard feature will not be able to correctly determine the active insulin in your system. Consult with your healthcare professional on how long you need to wait after a manual injection before you can rely on the active insulin calculation of your Bolus Wizard feature.

Consumables

The pumps use disposable reservoirs and infusion sets for insulin delivery. Installation instructions for Paradigm reservoir and Paradigm compatible infusion sets are provided in the *Starting on insulin* chapter.

- **Reservoirs** — The 515 pump is only used with the 176-unit Paradigm reservoir (MMT-326A). The 715 pump can be used with either the 300-unit Paradigm reservoir (MMT-332A) or the 176-unit reservoir, depending on your insulin needs.
- **Infusion sets** — Medtronic Diabetes provides a variety of Paradigm compatible infusion sets to fit your needs. Contact your healthcare professional who will assist you to choose an infusion set that fits your needs.

WARNING: For your protection the pump has undergone extensive testing to confirm appropriate operation when used with Paradigm reservoirs and Paradigm compatible infusion sets manufactured or distributed by Medtronic Diabetes. We recommend using Medtronic Diabetes infusion sets and reservoirs as we cannot guarantee appropriate operation if the pump is used with reservoirs or infusion sets offered by third-parties and therefore we are not responsible for any injury or malfunctioning of the pump that may occur in association with such use.

Accessories

- **Meter** – Your pump can be used with an optional blood glucose meter powered by MWT1 technology (where or if available). MWT1 is the wireless Radio Frequency (RF) technology that is used to transmit information from the meter to the pump. You can program your pump to automatically receive your BG reading from this meter. All meters referenced in this user guide are blood glucose meters supported by MWT1 technology.
- **Remote control** – The optional Paradigm remote control can be used with the pump to deliver normal boluses and suspend/resume the pump from a distant location. (This User Guide provides programming instructions for the remote control. Refer to the remote control User Guide for operating instructions.)
- **CareLink USB Upload Device** – The Medtronic Diabetes CareLink USB is used to download the Paradigm 515 or 715 pump data to the diabetes management software using a USB port on your computer.

To order supplies, call 800-646-4633 (1-800-MiniMed), +1-818-362-5958 (outside U.S.), refer to the contacts list at the beginning of this user guide, or visit our web site at www.medtronicdiabetes.com.

How to wear your pump





There are different ways to wear your pump. Medtronic Diabetes has optional accessories that can hide, protect, and add to the convenience of wearing a pump. Refer to the accessories catalog or the website (www.medtronicdiabetes.com) for more information.

- **Holster** – To wear the pump on your belt.
- **Pump clip** – To wear the pump underneath your clothing.
- **Activity guard** – If you are active in sports, or you are a child, use the guard to protect the pump from disconnecting.
- **Leather case** – Fine leather lined with nylon. Styling complements business and formal wear. A flap with a hook-and-loop fastener provides easy access for programming. Wear it vertically with the built-in belt clip.

How to use this guide

NOTE: This user guide shows sample screens only. Your pump screens may be slightly different.

For step-by-step instructions, refer to the appropriate sections in this guide. Refer to the Glossary for definitions of terms and functions. The terms and symbols used in this guide are in the table below.

Conventions	Meaning
Press	to push and release the button
Hold	to push and keep pressure on the button
Select	to press  or  to highlight a screen item you want to select
Exit the menus	press ESC until the HOME screen appears
Pump Buttons	always bold and uppercase; for example, ESC , ACT
Screen and menu names	always uppercase; for example, MAIN MENU , REWIND screen
Menu selections	always bold; for example, 24-Hour Setup , On , Off
Flashing (blinking) screen item	you can change the value for that item with the  or  buttons
NOTE and TIP	additional helpful information
CAUTION	warns of a potential hazard which, if not avoided, may result in minor or moderate injury to the equipment
WARNING	notifies you of a potential hazard which, if not avoided, could result in death or serious injury. It may also describe potential serious adverse reactions and safety hazards
Go to the...screen.	when a step instructs you to go to a certain screen, the path to that screen is shown. For example: Go to the ALARM MENU . Main > Utilities > Alarm <ol style="list-style-type: none">1 From the MAIN MENU, select Utilities and press ACT.2 In the UTILITIES MENU, select Alarm and press ACT.3 The ALARM MENU appears.

User safety

Indications

Pump

The Paradigm 515/715 pump system is indicated for the continuous delivery of insulin, at set and variable rates, for the management of diabetes mellitus in persons requiring insulin.

Contraindications

Pump therapy is not recommended for people who are unwilling or unable to perform a minimum of four blood glucose tests per day and to maintain contact with their healthcare professional. Successful insulin pump therapy requires sufficient vision or hearing to allow recognition of the pump signals and alarms.

Warnings

Pump

The drive support cap should appear slightly indented at all times (as shown in the image). If you notice that the cap is loose, or sticking out, discontinue use of the pump and contact our 24 Hour HelpLine at 1 800 646 4633 to arrange for your pump to be replaced. **Do not press on the drive support cap if it is sticking out. Pushing on the drive support cap may result in unintended delivery of insulin, which can cause hypoglycemia.**

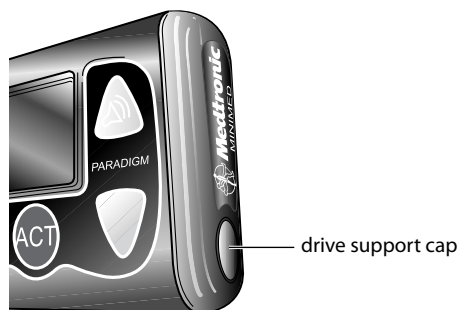

Reservoir and infusion sets

Standard Luer sets are not compatible with the Medtronic MiniMed Paradigm pump. Medtronic Diabetes Paradigm reservoir and Paradigm compatible infusion sets are specifically designed for use with the pump. Do not modify your Paradigm reservoir or Paradigm compatible infusion set.

Do not put any other drugs/medications inside your reservoir to use with this pump. Only insulin that has been prescribed by your physician can be used in this pump.

Tubing Connector

If insulin, or any liquid, gets inside the tubing connector, it can temporarily block the vents that allow the pump to properly prime the infusion set. This may result in the delivery of too little or too much insulin, which can cause hypoglycemia or hyperglycemia. To prevent liquid from getting inside the tubing connector, after you fill the reservoir make sure you hold the insulin vial upright when you remove the reservoir from the transfer guard. If you do not hold the insulin vial upright, insulin can get on the top of the reservoir and could transfer liquid into the tubing connector. If any liquid gets on the top of the reservoir or inside the tubing connector when you change your infusion set, start over with a new reservoir and infusion set. For instructions on setting up your reservoir, see *Filling the reservoir*, on page 58. For instructions on changing your infusion set, see *Changing your infusion set*, on page 61.

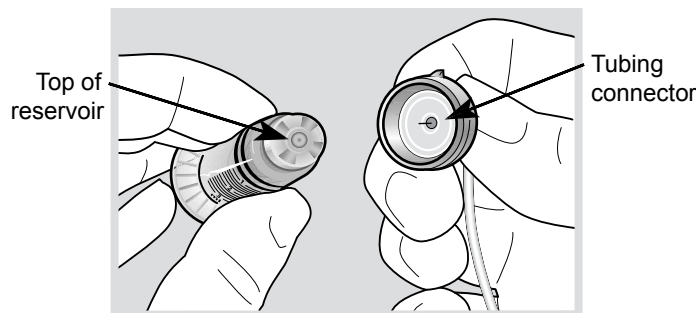

Magnetic fields

Do not use pump cases that have a magnetic clasp.

Do not expose your insulin pump to MRI equipment or other devices that generate very strong magnetic fields. The magnetic fields in the immediate vicinity of these devices can damage the part of the pump's motor that regulates insulin delivery, possibly resulting in over-delivery and severe hypoglycemia.

Your pump must be removed and kept outside the room during magnetic resonance imaging (MRI) procedures.

If your pump is inadvertently exposed to a strong magnetic field, discontinue use and contact our 24 Hour HelpLine for further assistance.

X-rays, MRIs and CT scans

If you are going to have an X-ray, CT scan, MRI or other type of exposure to radiation, **take off your pump, meter and remote control** before entering a room containing any of this equipment.

The Paradigm pump is designed to withstand common electromagnetic interference, including airport security systems. Be sure to carry the Airport Card provided, when you are traveling.

Precautions

Although the pump has multiple safety alarms, it cannot notify you if the set is leaking or the insulin has lost its potency. It is essential, therefore, that you test your blood glucose levels at least four times per day. If your blood glucose is out of range, check the pump and the infusion set to ensure that the necessary amount of insulin is being delivered.

Avoid extreme temperatures

- 1 Avoid exposure of your pump and remote control to temperatures above 108°F (42°C) or below 34°F (1°C).
- 2 Insulin solutions freeze near 32°F (0°C) and degrade at high temperatures. If you are outside in cold weather, wear your pump close to your body and cover it with warm clothing. If you are in a warm environment, take measures to keep your pump and insulin cool.
- 3 Do not steam, sterilize or autoclave your pump or remote control.

Infusion sets and sites

Avoid using an infusion site that will be irritated by clothing and accessories, or by rigorous stretching and exercise.

Notice

CAUTION: Any changes or modifications to the devices not expressly approved by Medtronic Diabetes could void your ability to operate the equipment.

Insulin pump and RF accessories

The pump, meter and remote control comply with the United States Federal Communications Commission and international standards for electromagnetic compatibility.

Do not use the RF meter to send your blood glucose reading to the pump while on an aircraft. Manually enter your blood glucose.

These devices comply with Part 15 of the FCC Rules. Operation is subject to the following two conditions: (1) This device may not cause harmful interference, and (2) this device must accept any interference received, including interference that may cause undesirable operation. It does not interfere with any RF signals transmitted from outside sources.

These standards are designed to provide reasonable protection against excessive radio frequency interference and prevent undesirable operation of the device from unwanted electromagnetic interference. Operation is subject to the following two conditions:

- 1 This device has been tested and found to comply with the regulations governing such devices in your area. For the specific regulation and test results for your area, please contact our 24 Hour HelpLine.
- 2 This device generates, uses, and can radiate radio frequency energy and, if installed and used in accordance with the instruction, may cause harmful interference to radio communications. If the device does cause interference to radio or television reception, you are encouraged to try to correct the interference by one or more of the following measures:
 - Reorient or relocate the insulin pump/remote control/ meter
 - Increase the separation between the insulin pump/remote control/meter and the device that is receiving/emitting interference

The meter sends information to the pump using radio frequency. If other devices that use radio frequency are in use, such as cell phones, cordless phones and wireless networks, they may prevent communication between the pump and the meter. This interference will not cause any incorrect data to be sent and will not cause any harm to your pump or meter. Moving away from or turning off these other devices may allow communication. Refer to the *Troubleshooting and alarms* chapter to correct interference problems you may have.

If you have questions, please contact our 24 Hour HelpLine.

RF interference from other devices

Common consumer electronic devices that transmit in the same frequency band used by the optional RF glucose meters may prevent the pump from receiving the glucose information sent by those meters. Most cellular (mobile) phones and 900 MHz cordless phones, when transmitting or receiving, may interrupt RF glucose meter-pump communication. It is likely that other devices operating in similar frequency ranges will have a similar effect. This interference, however, will not cause any incorrect data to be sent and will not cause any harm to your RF glucose meter.

Communication problems can usually be resolved by:

- ensuring that there is less than 6 feet (1.8 meters) between the pump and the RF glucose meter;
- turning off or moving away from other RF transmitting devices; or
- reorienting or relocating the RF glucose meter or pump, or both.

Communications problems may also occur due to cellular telephone interference. Testing conducted with several different cellular telephones indicates that, while a glucose value is being transmitted, using a cell phone within 12 inches (31 cm) of receiving devices, transmitters or RF glucose meters can interfere with reception of the transmitted values. In the event of such interference, normal communication can be re-established by:

- turning the cell phone off; or
- keeping the cell phone at least 12 inches away from the pump or glucose meter when a glucose measurement is being transmitted.

If you have questions, please contact your local Medtronic Diabetes representative.

Introduction to pump therapy

Theory of insulin pump therapy

Insulin pumps deliver insulin closer to the way the human pancreas delivers insulin than any other method of treating diabetes.

All people, with or without diabetes, need background insulin for normal functions of the body without food. They also need a dose of insulin on demand - when food is eaten. People without diabetes can trust that their pancreas will produce this insulin for them. People with diabetes need to take insulin in a way that is most like the way a pancreas produces it.

Most people with diabetes who take more than one daily injection, use long-acting insulin. This takes care of their background insulin needs. They take fast-acting insulin for food. When using an insulin pump, only fast-acting insulin is used. You control when and at what rate your insulin is delivered.

Insulin pump therapy allows you to set a **basal rate**, or background insulin. This is delivered all throughout the day and night for normal body function without food. When you exercise, you can reduce the basal rate so that your blood glucose (BG) does not drop too low. When you are sick or have an infection, you can increase the basal rate. This will keep your BG from going up too high.

Insulin pump therapy allows you to give a **bolus**, or dose of insulin on demand - when you eat. You can also increase or decrease your meal bolus based on the foods you choose to eat. A bolus may also be used to lower an elevated BG. This is called a correction bolus.

The Paradigm pump also contains an optional feature called the Bolus Wizard. This does the math for the required bolus amount based on your personal settings. The Bolus Wizard will use your BG reading, carbohydrate intake, and active insulin when coming up with your bolus amount.

Remember, the pump uses only fast-acting insulin. This means you will not need to follow as rigid a schedule as you did before. There is no long-acting insulin telling you when you should eat or when you will need more insulin.

Sound exciting? It is exciting because not only can you manage your blood glucose more easily, your lifestyle can be easier too.

As long as you are ready to learn how to use the pump, the pump can work for you.

Understanding pump therapy

If you are new to pump therapy, you will need the following data from your healthcare professional. Gather this before going to your pump start appointment. If you are unsure, contact your healthcare professional or pump trainer for guidance.

Basal rate

Basal insulin is needed to maintain your target glucose values when you are not eating. Your pump allows up to 48 basal rates to be programmed. Your healthcare professional may only have you program one or two basal rates when you start pump therapy.

Meal bolus

Deliver a meal bolus before eating carbohydrates. Your insulin to carbohydrate ratio is the amount of insulin required to cover a given number of carbohydrates or exchanges. This ratio gives you an idea of how much of an insulin bolus you should take when eating carbohydrates.

Gram counting

1.0 unit of insulin for _____ grams of carbohydrate

Or

Exchange counting

_____ units of insulin for each carbohydrate exchange

BG targets

The Bolus Wizard will use your BG targets to calculate a correction dose. Keeping your BG within target range is key to living well with diabetes. Your healthcare professional should help you decide these targets.

Insulin sensitivity

Insulin sensitivity is used to decide a correction bolus for a high BG. This is how much your blood glucose will be dropped with 1 unit of insulin.

1 unit of insulin will lower BG _____ mmol/L (mg/dL).

Active Insulin

Active insulin is the bolus insulin that has already been delivered to your body, but has not yet been used. The pump considers your active insulin time setting in determining any active insulin still in your body from prior boluses. This may help prevent hypoglycemia caused by over-correcting for high blood glucose.

Blood glucose and A1C testing

When you check your blood glucose with a meter, you measure blood glucose at the moment you perform the test. This number gives you key feedback for making present and day-to-day adjustments in your diabetes management. The A1C test, done at your doctor's, shows you your average blood glucose over the last 60 to 90 days. Both blood glucose and A1C testing are necessary for good diabetes management.

BG testing

With any insulin therapy, you must monitor your blood glucose 4 to 6 times a day. With insulin pump therapy, blood glucose testing gives you correct feedback. It also allows you to make prompt changes based on the results. It alerts you to high blood glucose readings that need changing. It allows you to adjust your insulin to carbohydrate ratio for certain foods. Your pump only uses fast-acting insulin; as a result, you have no long-acting insulin as a back-up. Therefore, if your insulin delivery is disrupted on pump therapy, your blood glucose can go dangerously high fairly fast. This can happen much faster than it could when you were using daily injections with long-acting insulin. Blood glucose testing is needed to alert you to high blood glucose so you can prevent diabetic ketoacidosis (DKA).

A1C

A1C testing also plays a key part in diabetes management. Sustained high BG levels can cause serious long-term problems. These problems may be prevented and/or delayed if you maintain your blood glucose levels close to normal. The best measure of your overall blood glucose is the A1C test. It has been proven that an A1C level of 7.0 or less greatly reduces the risk of problems from diabetes. But, any reduction in A1C is a plus. ADA Clinical Practice Recommendations state that your A1C should be tested at least every 3 months by your healthcare professional.

Your healthcare professional will rely on the results of your blood glucose tests to make changes in your pump settings. The results of your A1C tests are used to assess your overall blood glucose control.

If you are on pump therapy, you must test your BG at least:

- Upon waking up
- Before each meal
- At bedtime
- If you feel nauseous
- One hour after any BG above 250 mg/dL (13.9 mmol/L)

Below are target guidelines from the American Diabetes Association for adults with diabetes. Consult your healthcare professional to find out what your targets should be.

Summary of recommendations for adults with diabetes mellitus	
Glycemic control A1C	<7.0 percent
Preprandial plasma glucose (before meals)	90-130 mg/dL (5.0-7.2 mmol/L)
Peak postprandial plasma glucose (1-2 hours after meals)	<180 mg/dL (<10.0 mmol/L)

Correlation between A1C level and blood glucose levels		
A1C (percent)	Mean plasma glucose	
	mg/dL	mmol/L
6	135	7.5
7	170	9.5
8	205	11.5
9	240	13.5
10	275	15.5
11	310	17.5

Correlation between A1C level and blood glucose levels		
A1C (percent)	Mean plasma glucose	
	mg/dL	mmol/L
12	345	19.5
American Diabetes Association. Diabetes Care. "Tests of Glycemia in Diabetes." & "Standards of Medical Care." Vol. 31, Supplement 1, January 2008. S18.		

Low blood glucose (hypoglycemia)

Low blood glucose can occur while using the pump for the same reasons it can while using daily injections.

Not enough food

Too much insulin

More exercise than usual

Drinking alcoholic beverages

As you know, you cannot always avoid low blood glucose. It is important that you create a routine to follow when your BG is low. If you have a routine, you will have something ready to treat a low BG. This makes it less likely you will over-treat and cause your blood glucose to go up too much.

It is best to use something that you can always carry with you. Choose a food that is all carbohydrate because it will be fast acting. Avoid using high fat foods such as chocolate. They will not work fast enough, and you may also end up over-treating your lows. When treating hypoglycemia, start with 15 grams of fast acting carbohydrates. Do not keep eating until you feel better. Eat the required amount and stop. The feelings will pass and you will be grateful that you did not overdo it.

Some people with diabetes know when their blood glucose is low and some do not. If you are not aware of hypoglycemia, it is important to test your blood glucose more often. Everyone with diabetes should test before driving a car to assure safety on the road. Blood glucose should be above 100 mg/dL (5.6 mmol/L) before driving and at bedtime.

Tip: We suggest that you use glucose tablets to treat a low. These tablets contain a known, pre-measured amount of carbohydrate, and are in handy packages that you can carry in your pocket, purse, or car.

Hypoglycemia protocol: the rule of 15

If blood glucose is 70 mg/dL (3.9 mmol/L) or below:

- Eat 15 grams of fast acting carbohydrate
- Check BG again in 15 minutes; if not above 70 mg/dL (3.9 mmol/L), repeat treatment
- Check BG again in 15 minutes; if still not above 70 mg/dL (3.9 mmol/L), repeat treatment again.
- Contact your healthcare professional

These items have 15 grams of fast acting carbohydrates:

- Glucose tablets (three, 5-gram tablets or four, 4-gram tablets)
- 4 oz. of juice or soda (not diet)
- 6-7 Life Savers® (hard candies)
- 1 tablespoon of table sugar or honey

High blood glucose (hyperglycemia)

High blood glucose can occur while using the pump for the same reasons it can while using daily injections. It can also occur for reasons that are unique to insulin pump therapy.

Too much food,

Not enough insulin,

Loss of insulin strength,

Disruption of insulin delivery from the pump.

The goal of treating hyperglycemia is to prevent Diabetic Ketoacidosis (DKA) and delay or prevent diabetes problems due to high blood glucose over a lengthy period of time.

If for any reason you are not getting the proper amount of insulin, your blood glucose rises quickly. This can occur with insulin pump therapy from the disruption of insulin delivery. This happens from the infusion set coming out, clogs, or leaks, or insulin not being absorbed right.

Since the pump only delivers fast-acting insulin, hyperglycemia can occur rapidly. Your healthcare professional will give you data needed for you to determine your correction bolus. This correction dose is based on your insulin sensitivity.

It is vital that you know these guidelines in the hyperglycemia protocol.

Hyperglycemia protocol

If one blood glucose reading is above 250 mg/dL (13.9 mmol/L):

- Take a correction bolus right away
- Test BG in one hour

If the second blood glucose is above 250 mg/dL (13.9 mmol/L):

- Take an insulin injection by syringe (not through the pump). The amount should be the same as if you were taking a correction bolus.
- Change the entire infusion set system (new reservoir, infusion set, and cannula). Consider changing the insulin vial if you believe that the insulin is no longer stable.
- Check urine for ketones and call your healthcare professional if ketones are present.
- Drink liquid with no calories every 30 minutes (for example: 8 oz. diet ginger ale, broth, water).
- Test blood glucose every 2 hours and keep taking correction insulin until blood glucose reaches target.
- Call your healthcare professional if your blood glucose and urine ketones remain high or you are unable to drink.

Treating hyperglycemia from illness or infection through insulin pump therapy will be discussed on the following pages.

Diabetes ketoacidosis (DKA)

DKA results from untreated hyperglycemia. DKA is a serious medical problem that needs treatment right away. The insulin pump therapy uses only fast-acting insulin, so DKA can occur rapidly if insulin delivery is disrupted. It is important that you understand these guidelines.

Preventing DKA

If you have nausea or vomiting, immediately check your blood glucose and ketones. If your blood glucose is above 250 mg/dL (13.9 mmol/L) **and/or ketones are present:**

- Take an injection of fast-acting or regular-acting insulin with a syringe (not through the pump). The amount should be the same as if you were taking a correction bolus. If ketones are present, more insulin may be needed. Contact your healthcare professional for guidelines for insulin doses especially when ketones are present.
- Change the entire infusion set system (new reservoir, infusion set, and cannula). Consider changing the insulin vial if you believe that the insulin is no longer stable.
- Call your healthcare professional.

- Troubleshoot the pump. If help is needed, please call our 24 Hour HelpLine for assistance.
- Drink liquids with no calories every 30 minutes (for example: 8 oz. diet ginger ale, broth, water).
- Check your blood glucose and ketones in one hour.
- Continue to take insulin as discussed with your healthcare professional.
- Call your healthcare professional right away if your blood glucose and ketones are not decreasing, or you cannot drink fluids.
- Continue to test blood glucose and ketones. Continue to take correction insulin injections as told until your blood glucose reaches your target level.
- If your blood glucose is less than 200 mg/dL (11.1 mmol/L) and ketones are present, drink liquids with calories. Some examples of caloric fluids are juice and non-diet soda. Also, extra insulin may be needed. Contact your healthcare professional for guidelines for insulin doses when ketones are present.

Tip: You should have a meter, glucose strips, and ketones strips handy at all times. This way you are always ready to test your blood glucose and ketones.

Sick day management

Managing diabetes during an illness or infection requires frequent blood glucose and urine ketone testing. Illness and infection put extra stress on the body and often raise blood glucose. The insulin pump allows you to make changes. It lets you quickly and easily respond to blood glucose changes due to illness and infection.

Even if you are not able to eat, you need insulin. Depending on blood glucose testing, you may or may not need to adjust your basal insulin to cover your needs. You may also need to take frequent correction boluses during illness.

Sick day protocol

- Test your blood glucose every 2 hours, 24 hours a day.
- Check urine ketones every time you urinate.
- If you are throwing up and/or have ketones, you must call your healthcare professional. They will give you the proper treatment with fluids and insulin to avoid DKA.
- Consult your healthcare professional about taking more insulin if your blood glucose is 250 mg/dL (13.9 mmol/L) or higher. Also take more insulin when ketones are fair or large.



- Keep exact records of your blood glucose values, ketones, medication, temperature and all other signs.
- Keep in mind that you need more insulin and fluids when there are urine ketones. **This is true even if your blood glucose is within your target range.**

Sick day supplies

You should have the supplies listed below in the house at all times, and carry them with you when you travel:

- Fluids that have sugar (regular soda, juice, jello) to replace solid food.
- Sugar-free liquids (diet drinks, bouillon, water) for replacing lost fluids.
- Thermometer.
- Sugar free medicine for fever, cough, congestion, nausea and vomiting.
- Extra blood glucose and ketone strips.
- Glucagon emergency kit in case of severe hypoglycemia. This can be used if you cannot eat or are unconscious.

Caring for your diabetes when you are sick is worthwhile and can be a challenge. If you are too sick to watch your diabetes carefully, ask a friend or family member to help. If there is no one to help you, ask your healthcare professional for help.

Nutrition

Good nutrition and making healthy choices are important for everyone. Additionally, for those with diabetes, it is more important to know the nutrient content in food, and how the nutrients affect blood glucose.

Carbohydrates have the most effect on blood glucose, notably within a few hours of being eaten. Counting carbohydrates allows you to match your insulin dose to the food you are eating. This is your insulin to carbohydrate ratio. Although fat and protein can affect your blood glucose when eaten in large amounts, carbohydrates affect blood glucose the most.

Consult with your healthcare professional for your personal nutritional guidelines.

Carbohydrate counting

With insulin pump therapy, you must take a bolus for the carbohydrates you eat. You need to count the carbohydrates you plan to eat to see how much insulin to take.

There are two basic methods to count carbohydrates, and in truth, they are very much alike. Many people use parts of both of the two methods.

Carbohydrate gram counting

With this method, you add up the exact number of grams of carbohydrate in each meal. Food labels, food list and meal planning books are great tools for carbohydrate gram counting.

Carbohydrate exchange system

This method uses food groups called exchange groups. One exchange with carbohydrate has about 15 grams of carbohydrate.

1 bread exchange	1 fruit exchange	1 milk exchange
15 grams carbohydrate	15 grams carbohydrate	12 to 15 grams carbohydrate

Foods with carbohydrates include:

- **starches and starchy vegetables**
- **fruits and fruit juices**
- **milk and milk products**
- **sugars and foods with sugar**

Facts on the nutrition labels on packaged food will help you to figure how much carbohydrate is in a certain food. There are a number of paperback books that list the grams of carbohydrates in many foods. These books are very helpful when you are eating foods without labels or are eating out. Also, if you know the exchange system, you can count carbohydrate exchanges.

Your healthcare professional will give you an insulin to carbohydrate ratio at the start. This will be a place to begin. It may need to be changed based on the results of your blood glucose readings after you eat.

Determining your meal bolus based on carbohydrate counting is not an exact science. Sometimes it takes trial and error to come up with the correct meal bolus for certain foods. If you are not sure how some foods affect your blood glucose, test your blood glucose 2 hours after eating. If your reading is too high or too low, adjust your meal bolus the next time you make that food choice.

As you start to learn carbohydrate counting, try to assess the carbohydrates in the food you are eating. Then look at the food labels to see how close you are.

Reading a food label

Use the Serving Size and Total Carbohydrates information on the food label to determine how many total grams of carbohydrate you will be eating. Then, use the insulin to carbohydrate ratio prescribed by your healthcare professional. This allows you to figure out how much insulin to take for the foods you eat.

The food label below shows 12 grams of carbohydrates for each 1 piece serving. If your carbohydrate ratio is 1 unit of insulin for every 12 grams of carbohydrate, you would need 1 unit of insulin for each 1 piece serving of this food.

Nutrition Facts Serving Size 1 piece (20g) Serving per Container 22
Amount Per Serving: Calories: 50
Fat Calories: 0
Total Fat 0g
Sodium 0g
Total Carbohydrates 12g
Sugars 11g
Protein 0g

Fat and blood glucose

Although fat does not have carbohydrate, it may affect your blood glucose level. Your blood glucose can be normal 2 hours after a meal with high fat foods. However, 4-6 hours later your blood glucose will increase. That is because the fat slows down the rate the carbohydrates are absorbed in that meal.

Foods with fat include:

- margarine
- salad dressing
- butter
- cream cheese
- oils
- nuts
- sour cream
- bacon
- mayonnaise
- fried foods
- whole milk
- high fat meats

Doctors and health experts suggest that all people, with or without diabetes, eat less total fat—namely less saturated fat. If you have high cholesterol or are trying to lose weight, it is key to limit the amount of fat you eat per day.

There are bolus type options available on your pump that can be helpful in handling the rare high-fat meal. Before using bolus type options, you should be at ease using basic pump features and consult with your healthcare professional.

Protein and blood glucose

Protein has little effect on blood glucose when eaten in moderate amounts, and normally does not require any insulin.

Sources of protein include:

- meat
- eggs
- tofu
- fish
- cheese
- dried beans
- poultry
- peanut butter
- dried peas

Protein needs are the same for people with and without diabetes, unless kidney disease is present. Most people eat more protein than they need. Protein does not need to be part of every meal. In general, five to seven ounces a day is enough. If you have high cholesterol or are trying to lose weight, eat leaner proteins such as chicken and fish.

Other things that affect blood glucose

Fiber may slow down the rise in blood glucose after a meal. Fiber grams are not absorbed. They can be subtracted from the Total Carbohydrate amount for foods or meals with more than 5 grams of fiber. Fiber is an important part of a healthy diet. Suggestions for fiber intake are the same for people with and without diabetes.

Sodium (salt) has no effect on blood glucose. Moderate sodium intake is suggested for people with or without diabetes. If you have high blood pressure or are affected by sodium, limit the amount of sodium in your diet.

Alcohol can cause low blood glucose by slowing down the release of glucose from the liver. This glucose release keeps blood glucose in target between meals. Therefore, food should be eaten while having a drink with alcohol. The carbohydrate content of different types of alcohol can be found in carbohydrate counting books. Consult your healthcare professional for guidelines on bolusing for alcohol.

Vitamins and minerals have no effect on blood glucose.

Healthy eating habits

Insulin pump therapy gives you the choice of when, what and how much to eat without impacting blood glucose control. This gives you the flexibility to sleep-in, postpone or skip meals, and eat snacks—the same as people who do not have diabetes. Be careful to not abuse this freedom and compromise your nutritional health. All people need to make healthy food choices to be mentally and physically healthy.

It is not an exact science to figure your meal bolus based on carbohydrate counting. Sometimes it takes trial and error to figure the correct meal bolus for certain foods. If you are unsure how certain foods will effect your blood glucose, test your blood glucose 2 hours after you eat. Keep records of foods that you eat on regular basis. Note the bolus amounts and post-prandial readings for each entry. If your reading is too high or too low, adjust your meal bolus the next time you make that food choice.

Exercise

Your body needs insulin and carbohydrate to provide cells with energy during exercise. How much insulin and carbohydrates you need varies with the types of exercise and with how often you exercise. Using an insulin pump during exercise allows you to reduce your basal rate instead of eating extra carbohydrate. Before, you needed to eat extra carbohydrate to make up for the glucose lowering effect exercise often has on blood glucose. It takes trial and error to get the balance right.

The body needs insulin during exercise. Therefore, it is not suggested that you stop the pump unless the exercise is for a short amount of time (1 hour or less). If you need to remove the pump for more than 1 hour, refer to the *If you remove your pump* section in the *The basics* chapter.

If you do an exercise that on average lowers your blood glucose, you can use the temporary basal rate feature. You can use this feature to lower the amount of insulin delivered and reduce the risk of hypoglycemia. You may also choose to change your basal rate pattern for the days you exercise.

It takes a period of time to determine how much to adjust your basal rate during exercise. Record your blood glucose before, during and after exercise to figure the proper reduction in your basal rate. Record any carbohydrates that you have eaten during the exercise period. There is no magic formula that will tell you just what to do. You have to test often to figure out the basal rate that you need during exercise.

The basics

Your pump

CAUTION: Never use sharp objects to press the buttons on your Paradigm pump as this can damage the buttons or compromise the seal of the pump. Some examples of sharp objects that may damage your keypad are fingernail files, pens or pencils, paper clips, knives, scissors, and keys.

Take a look at your pump. The reservoir window allows you to view the insulin in the reservoir. The reservoir, with the tubing connector attached, is inserted into the reservoir compartment of the pump.

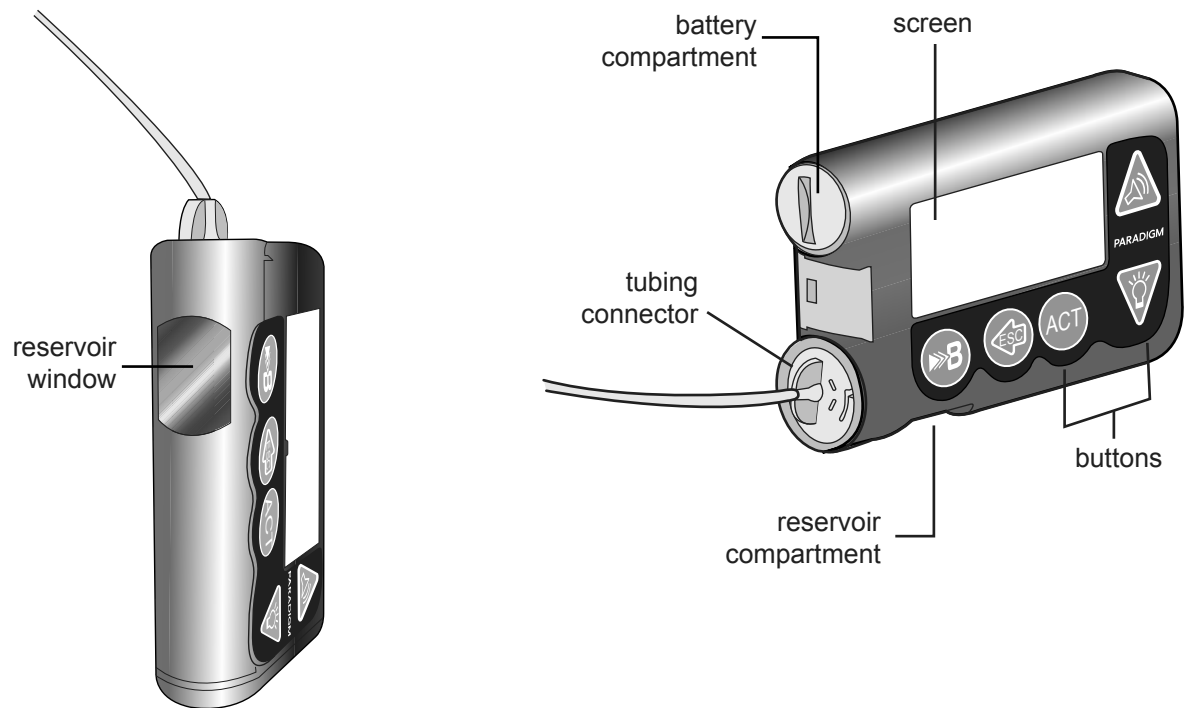

Install battery

CAUTION: Do not use a rechargeable or carbon zinc battery in your pump. For best results use a new Energizer AAA alkaline battery, size E92, type LR03.

Medtronic Diabetes designed the pump to only accept a NEW battery. As a safety measure, if you install a battery that does not have full power, the WEAK BATTERY or FAILED BATT TEST alarm may sound. If you receive a WEAK BATTERY alarm, respond to the alarm and continue. The pump will still operate normally, but with a decreased battery life. The pump uses one AAA alkaline battery.

- 1 Make sure all the following apply:
 - Clear (ESC, ACT) any alarms and/or alerts before removing and replacing the battery
 - Make sure the pump is at the HOME (idle) screen when you remove the battery.
 - Do NOT remove the battery during a bolus or prime delivery.
- 2 Use the edge of a coin to remove the battery cap. Turn the cap in a counter-clockwise direction.
- 3 Remove the old battery and dispose of it per the disposable requirements of your state or country. Put the new battery in the pump with the negative end [-] symbol going in first. Check the label on the back of the pump to make sure the battery is inserted correctly.

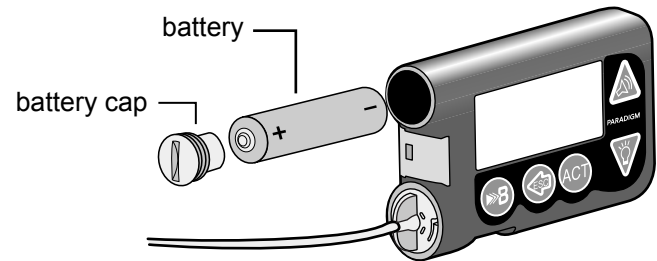

NOTE: Do not use batteries that have been in cold storage (i.e., in the refrigerator or your car in the winter).

- 4 Place the battery cap in the pump and tighten so the slot is aligned horizontally with the pump as shown here:

CAUTION: Do NOT over-tighten the battery cap. You should not turn the cap more than four half turns. If you over-tighten the cap you may not be able to remove it, and you can damage your pump.

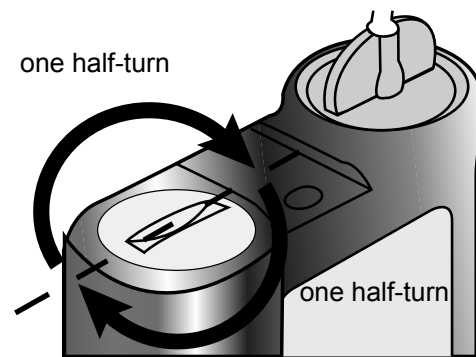

- 5 While the pump turns on, it will show one or more screens until the HOME screen appears.

If the HOME screen does not appear, do these steps:

- a. Check that the battery is inserted correctly. If the battery has been installed backwards, remove the battery and install it properly.
 - b. If your pump still does not turn on or you get a FAILED BATT TEST alarm, remove and replace the battery with a new one.
 - c. If the pump is still not on, call our 24 Hour HelpLine.
- 6 Check to make sure the time and date are correct. If more than 5 minutes have passed since you removed the battery, you will be prompted to check the time and date. Refer to the *Setting the time and date* section in the *Basic programming* chapter for programming instructions.
- 7 Press **ESC** to view the STATUS screen, making sure no alarms are active. If an alarm is active, follow the instructions on the screen.









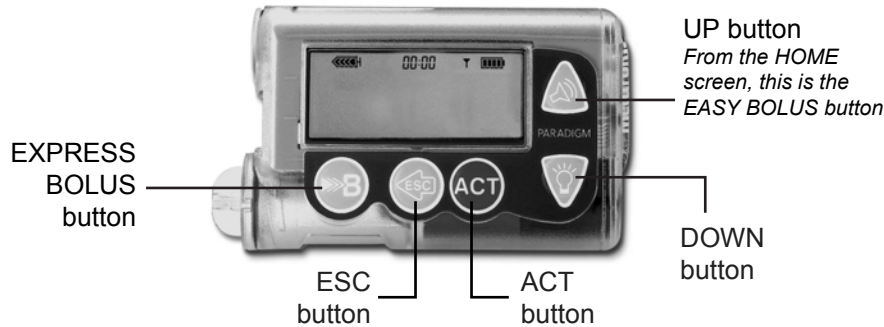

HOME screen

Pump buttons

The buttons on the pump are used to navigate through the menus and screens, and to program the features of the pump.



From the HOME screen	From the menus and programming screens
<p> EASY BOLUS™ button- Shortcut to set and deliver an Easy Bolus.</p> <p> Turns the backlight on/off from the HOME screen.</p> <p> ACT Opens the MAIN MENU.</p>	<p> Increases / decreases the value of a flashing item. Scrolls up and down the items in a list.</p> <p> ACT Accepts a selected menu item or activates a selected setting.</p> <p> ESC Returns to previous screen or exits the menu. Backs out of unintentional menu selections if the ACT button has not been pressed yet.</p> <p> EXPRESS BOLUS button: Short-cut to the SET BOLUS MENU or Bolus Wizard to set up any bolus.</p>

From the HOME screen	From the menus and programming screens
	Press simultaneously with  to turn on backlight when in the menus or use as a Shift button by pressing it in combination with another button to access certain features.

The pump screen

The screen shows five lines of text at one time. The first is the operating mode. The second is the current open menu or function. The last three lines show either information or text that you can select for the current function.

NOTE: The screen text in the examples used in this guide might not exactly match the text on your pump screen. Please follow your pump screen instructions. If you have any questions, contact our 24 Hour HelpLine.

HOME screen

The HOME screen serves as the starting point to access the programming screens. When no buttons are pressed for about 30 seconds, the pump returns to this screen.

When you press **ACT** from the HOME screen, the **MAIN MENU** will appear.

When the pump is on, the following icons always appear across the top of the screen: reservoir volume icon, the time (12 or 24 hr), and the battery icon. If these do not appear, the pump is not operating.

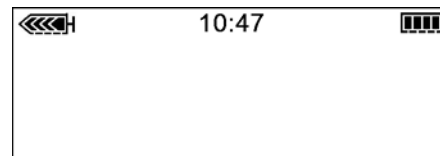

Screen icons

There are various icons that appear at the top of your pump screen, like the time, battery and reservoir icons mentioned above. The next sections describe what the icons mean.

Battery

The battery icon tells you how much usable life is left in your battery. There are four segments in the icon. Each segment represents approximately 25 percent of the usable battery life you have left until you reach Low Battery point. So if you only have one segment left you want to make sure you have a new battery available.



At least 75% left



Low battery

Time display

The current time of day is displayed across the top of the pump screen in the format you select—12-hour or 24-hour. The AM or PM is only displayed for the 12-hour format. For instructions on setting the time on your pump, see the *Setting the time and date* section in the Basic programming chapter.

00:00

24-Hr

12:00^{AM}

12-Hr

Time Display

Reservoir volume

The reservoir volume icon tells you how much insulin is in your pump. This icon is also divided into four segments. Each segment represents approximately 25 percent of the reservoir volume you have left. This allows you to be aware of how much insulin you have left in your pump. Refer to your STATUS screen to view the number of units left in the reservoir.



75 to 100% left



Less than 25% left

NOTE: For the Paradigm 715, your reservoir icon will only appear full if using a filled 300 unit Paradigm reservoir. The icon will not appear full if you use the 176 unit Paradigm reservoir.

Alert and alarm icons

An open circle (alert) or a solid circle (alarm) are displayed in the upper part of your pump screen only when there is an alert or alarm condition on your pump. For alarm and alert information, see the *Troubleshooting and alarms* chapter.





Alert icon

Alarm icon

Scroll bar

If there is more text than the screen can show, a scroll bar appears in the right side of the screen. Press  to view any additional text.

Screen backlight

When you press  from the HOME screen, the light on the screen turns on or off. During programming, the backlight can be turned on by pressing the  and the  together. The light will stay on while you are pressing any of the pump buttons. It will stay on as long as the current screen is active.

To conserve your battery, the backlight will turn off automatically while the pump is vibrating. After the vibration is finished, the light will turn back on. The backlight cannot be turned on in a Low Battery condition.

Beep/vibrate

Your pump will beep or vibrate to indicate activity. Refer to the *Setting your alert type* section in the *Utilities* chapter for setup instructions.

Operating modes

The screen lets you know when a special feature is active or if there is a condition that needs your attention. The active features and pump status will determine the operating mode. The screens for the three modes are shown below.

Normal mode

Mode for standard pump operations for normal basal and bolus delivery. No special features are active (i.e., basal patterns, temp basal, etc.). No alarms and no alerts exist.



Special mode

Indicates a special feature is active or an alert condition(s) exists. Special mode does not restrict any of the pump functions. When the pump is in Special mode, an open circle appears at the top of the screen and it will beep/vibrate periodically to remind you of the condition. The conditions and features that will put the pump in Special mode are:

- Low Reservoir condition
- Low Battery condition
- Block feature is on
- Dual or Square Wave bolus delivery
- Basal pattern A or B is active
- Temporary basal delivery
- Alert Silence is active

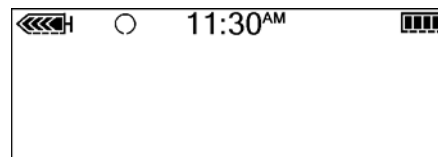

Attention mode

CAUTION: When the pump is in Attention mode (showing a solid circle alarm), all insulin deliveries are stopped.

Indicates insulin delivery has stopped. This can mean that the pump is in Suspend mode. It can also mean an alarm is active or an alarm condition exists that needs immediate attention for insulin delivery to resume. A solid circle appears at the top of the screen and the pump will beep periodically until either the pump is taken out of Suspend mode or the condition is cleared. The screen will show text describing the condition that put the pump in Attention mode. For example, if the reservoir is empty, EMPTY RESERVOIR will appear on the screen.

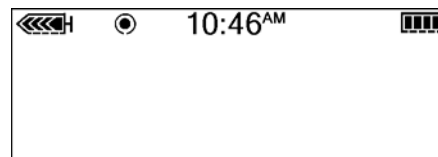

When the pump is in Attention mode, it will beep/vibrate periodically to remind you of the condition. The beep/vibrate frequency varies depending on the condition that put the pump in Attention mode. Refer to the *Alarm conditions* section in the *Troubleshooting and alarms* chapter for alarm conditions that will trigger the Attention mode. See the *Stopping your pump* section in the *Basic programming* chapter to learn about Suspend mode.

Menus

The MAIN MENU is the highest level menu. There are submenus, functions, status and programming screens in the lower menu levels. The menus are described in the following paragraphs.

Tip: If a screen item is flashing (blinking), during programming, press  or  to change the value.

MAIN MENU

Highest menu level in the menu system. When you press **ACT** from the HOME screen, the **MAIN MENU** will appear.

BOLUS MENU

Contains the settings and functions for bolus deliveries. The  button allows direct access to MANUAL BOLUS or to the BOLUS WIZARD feature without having to navigate through the menus. Refer to the *Basic programming* chapter for the manual bolus information or to the *Using the Bolus Wizard feature* chapter for bolusing using the Bolus Wizard feature.

SUSPEND

Stops all current insulin deliveries (basal, bolus and fixed prime). Refer to the *Stopping your pump* section in the *Basic programming* chapter for the manual bolus information or to the *Using the Bolus Wizard feature* for more information.

BASAL MENU

Contains the functions to setup and deliver your basal. Refer to the *Basal* section in the *Basic programming* chapter for more information.

PRIME MENU

Contains the functions to change your reservoir and fill the infusion set with insulin. Refer to the *Changing your infusion set* section in the *Starting on insulin* chapter for more information.



UTILITIES MENU

Contains features for your safety and convenience. Refer to the *Utilities* chapter for more information.

STATUS screen

The STATUS screen shows information about what your pump is doing. Only check your pump status (press ESC) when you are not programming your pump. If you press ESC during programming, you will cancel the settings you are trying to enter.

The information that shows on the STATUS screen depends on the current activities and conditions of your pump.

- To open the STATUS screen, press **ESC** until the STATUS screen appears.
- To view more text on STATUS screen, press  or  to scroll and view all of the information.
- To exit the STATUS screen, press **ESC** until the STATUS screen disappears.

The screen includes information about:

- Recent insulin deliveries (basal and bolus)
- The amount of active insulin, if any
- Special features that are turned on
- Last alarm/alert that was cleared within 24 hours
- Most recent BG meter reading received within 24 hours
- Reservoir status
- Battery status
- Time and date

Refer to the *Pump Specifications* chapter for a complete list of the information that is available in the STATUS screen.

If you remove your pump

You may have an occasion when you need or want to remove your pump. If you have to remove and store your pump, it is recommended that you do the following: Keep a record of your current basal rates and use the *Save Settings* feature (see the *Utilities* chapter). To preserve battery life, reset the basal rates to 0 (zero), turn off the RF options (meter, remote), and set Auto-off to dashes or zeroes.

- Store your pump with the battery in place
- Keep a record of your current basal rates and use the *Save Settings* feature (see the *Saving the settings* section of the *Utilities* chapter).
- To preserve battery life, reset the basal rates to 0 (zero), turn off the RF options (meter, remote), and set Auto-off to dashes or zeroes.

Remember, your body still needs insulin while your pump is removed.

It is important that you consult with your healthcare professional to determine an alternate method of receiving your insulin. You can remove your pump for up to one hour without taking insulin. If you remove your pump for more than one hour, you will have to use another way to take your insulin, such as injections of fast-acting insulin, or reconnecting your pump to take boluses. Take the injection or bolus approximately every four hours. Calculate the amount of insulin to take based on the total of your basal insulin in four hours. Include the amount you need for meal and correction boluses. If you will have your pump off for several days, you will need to return to a multiple injection regimen.

Basic programming

Setting the time and date

Setting the correct time and date in your pump is necessary for accurate basal insulin delivery and allows you to keep an accurate record of your insulin delivery and other pump functions. You can select a 12-hour or 24-hour clock. You must reset the time and date if you receive a CHECK SETTINGS alarm or you clear your settings (Clear Settings function).

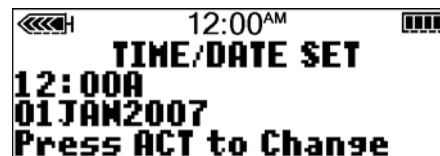

- 1 Go to the TIME/DATE SETUP screen.
Main > Utilities > Time/Date
- 2 Select 12-Hour Setup or 24-Hour Setup and press ACT.
- 3 Press ACT again to change the settings.



4 Change each of the settings as follows:

a. **Hour**

Change the hour. Press **ACT**.

For 12-hour setups, press  or  until the correct A (am) or P (pm) appears.



b. **Minutes**

Change the minutes. Press **ACT**.



c. **Year**

Change the year. Press **ACT**.

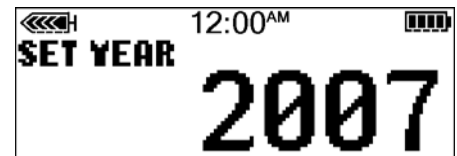

d. **Month**

Change the month. Press **ACT**.

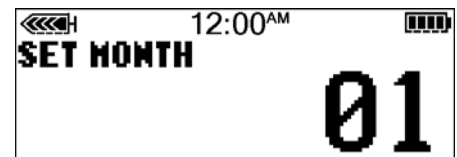

e. **Day**

Change the day. Press **ACT**.

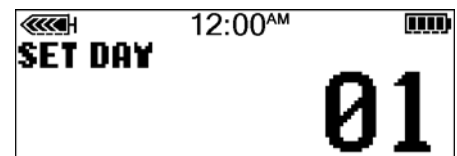

5 The **TIME SET AT** screen will show the settings that you programmed. Press **ACT** and exit the menus. Your time/date settings are complete.

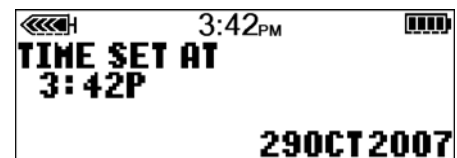

Selecting the language

The language shown on the pump screens can be changed. Some languages will not be available on all pumps. Before you can select another language, you need to set the time using the English screens. Refer to the previous section.

To change the language for your pump:

- 1 Go to the LANGUAGE MENU screen.
Main > Utilities > Language
- 2 Select your language, then press ACT.
- 3 The language setting is now changed. Exit the menus.



Bolus

There are three bolus types: Normal, Square Wave®, and Dual Wave®. This section gives instructions for a Normal bolus using the express bolus button and navigating through the menus. (For information about Square Wave and Dual Wave boluses, refer to the *Optimizing pump therapy* chapter.)

The Normal bolus delivers an immediate food or correction bolus. It can be delivered at any time except during another Normal bolus. During a Normal bolus, most pump features are disabled until after all the bolus has been delivered. The suspend function and the STATUS screen, however, are always available.

Setting the Normal Bolus

Normal bolus can be used to cover the carbohydrate in a meal or snack and/or to correct a blood glucose that is higher than your blood glucose target.

The following instructions are for a Normal bolus when the Bolus Wizard feature is turned off.

- 1 Go to the BOLUS MENU.

Main > Bolus

Select **Set Bolus** and press **ACT**. Go to step 2.

You can also use the  **EXPRESS BOLUS** button to get to step 2. Press  from your HOME screen.

- 2
 - a. If the **SET BOLUS** screen appears: (Dual/Square option is off) Go to step 3.
 - b. If the **BOLUS TYPE** screen appears: (Dual/Square Wave is on) Select **Normal Bolus** and press **ACT**. Go to step 3.
- 3 The **SET BOLUS** screen (or **SET NORMAL BOLUS** screen if the Dual/Square option is on) appears with 0.0 unit bolus amount flashing.
Enter your bolus amount and press **ACT**.

NOTE: *If you have BG Reminder turned On, a screen displays allowing you to accept or modify the length of time after this bolus before you are reminded to check your blood glucose. See the BG reminder section of this chapter for information about this feature.*

- 4 The **BOLUS DELIVERY** screen appears and the Normal bolus starts. The pump will beep/vibrate at the start of the bolus. As the bolus delivers, the amount shown on the screen will increase until the entire bolus has been delivered. When the bolus is finished, the pump will beep/vibrate again and the HOME screen will appear.
Below are some practice lessons that will help you understand this pump feature.

Normal meal bolus using the exchange system

Normal bolus can be used to cover the carbohydrate in a meal or snack and to correct a blood glucose that is higher than the target that was chosen for you.

Fred has been taught that he needs to take 1 unit of insulin for every carbohydrate exchange that he eats (every milk, every starch or every fruit). For lunch today he will eat:

Turkey sandwich with two slices of bread 2 starches

1 small apple 1 fruit

1 cup of non-fat milk 1 milk

Total carbohydrate exchanges = 4

Fred's lunch has a total of 4 carbohydrate exchanges so he will take a meal bolus of 4 units for his lunch.

Bolus practice:

Going through the menus, program a 2.0 unit Normal bolus now.

Check here if you were able to program it.

Using the express bolus button , program a 2.0 unit Normal bolus now.

Check here if you were able to program it.

NOTE: Make sure that you are not connected to your pump while practicing.

Normal meal bolus practice using exchanges:
Choose a meal you might eat and fill in the blanks.

Food: _____ exchange: _____
_____ exchange: _____
_____ exchange: _____
total exchanges: _____

You will take _____ units of insulin for each exchange. Your total bolus is _____ for this meal.

Normal meal bolus using carbohydrate counting

Lydia has been taught that she needs to take 1 unit of insulin for every 10 grams of carbohydrate. This is her insulin to carbohydrate ratio. For dinner she will have:

4 oz. broiled chicken	0 grams
2/3 cup of rice	30 grams
1/2 cup cooked broccoli	5 grams
1 oz. dinner roll	15 grams
1 tsp margarine	0 grams

total grams of carbohydrates = 50 grams

Lydia's dinner totals 50 grams of carbohydrate. Her insulin to carbohydrate ratio is 1 unit: 10 grams. She will take a meal bolus of 5 units for her dinner. She determined this by dividing 50 (total grams of carbohydrate) by 10 (insulin to carbohydrate ratio).

Choose a meal you might eat and fill in the blanks.

Food: _____ grams of carbohydrate: _____
_____ grams of carbohydrate: _____
_____ grams of carbohydrate: _____
total grams of carbohydrate: _____

Your insulin to carbohydrate ratio: 1 unit of insulin for _____ grams carbohydrate.
Divide your total carbohydrates by your insulin to carbohydrate ratio and take _____ units of insulin for your meal.

Meal bolus, correction bolus and insulin sensitivity

Jason is ready to eat his breakfast. He has calculated that he will need 4.0 units for his food. He tests his blood glucose and finds that it is 200 mg/dL (11.1 mmol/L). Jason knows that his blood glucose level is above his blood glucose target and will need additional insulin before he eats.

Jason's healthcare professional has determined the following for him:

Target BG: 110 mg/dL (6.1 mmol/L)

Insulin sensitivity¹: 36 mg/dL (2.0 mmol/L)

Jason determines that he will need a correction bolus of 2.5 units insulin to lower his elevated blood glucose. The 2.5 correction bolus will lower his current blood glucose of 200 mg/dL (11.1 mmol/L) to his target of 110 mg/dL (6.1 mmol/L).

- elevated blood glucose: $200 - 110 = 90$ mg/dL ($11.1 - 6.1 = 5$ mmol/L)
 - correction bolus: $90 / 36$ mg/dL (insulin sensitivity) ($5.0 / 2.0$ mmol/L) = 2.5 units
- (He will add this 2.5 correction bolus to the 4.0 units of insulin that he will need for his meal bolus. Jason will take a total bolus of 6.5 units.)

1. *Insulin sensitivity is the amount (in mmol/L or mg/dL) by which blood glucose will be lowered after taking 1 unit of insulin. Consult with your healthcare professional to determine your insulin sensitivity.*

Practice: Meal bolus

You have determined your meal bolus as: _____ units.

Your target blood glucose range is: _____ to _____ (average is _____).

Your current blood glucose level is: _____.

Your correction factor is: 1 unit of insulin will drop your blood glucose _____.

You will take _____ unit(s) of insulin to correct your high blood glucose level.

Your total bolus (meal bolus plus correction bolus) is _____.

Review your bolus deliveries

You can view a list of your bolus deliveries in the BOLUS HISTORY screen. This screen shows a list of the dates, times, units, and types for your last 24 boluses. This feature is helpful for record keeping or to check if you bolused for your last meal.

If a bolus was stopped before delivery was complete, the BOLUS HISTORY screen will show only the amount actually delivered. Refer to the *Bolus details* section for instructions about viewing bolus details.

Do the following steps to view the BOLUS HISTORY screen:

- 1 Go to the BOLUS HISTORY screen and scroll through the bolus deliveries.

Main > Bolus > Bolus History

If you used the Bolus Wizard feature to deliver any of these boluses, the screen shows the carbohydrate/food (CH) and blood glucose values that the Bolus Wizard feature used to calculate the boluses.

BOLUS HISTORY		
Last	12:48P	0.7N
26DEC	3:05P	0.2N
26DEC	7:30P	4.8S

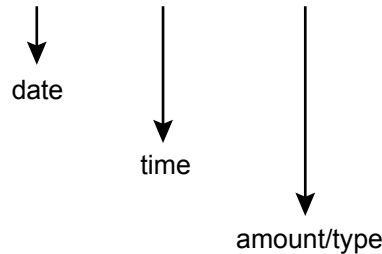

(with the Bolus Wizard feature)

BOLUS HISTORY		
Last	5:05P	4.0N
CH:	45	BG: 8.8
26DEC	12:51P	3.0N



N = Normal
 S = Square Wave
 DN = Normal part of dual wave bolus
 DS = Square part of dual wave bolus

- 2 Refer to the instructions in the *Bolus details* section, to see the details for any of these boluses.

Bolus details

You can view the details of any of the deliveries in the BOLUS HISTORY screen. The details include:

- bolus types: normal, square, and dual
- programmed bolus amount
- delivered bolus amount
- Bolus Wizard feature information (if used)

To see the details of any bolus, do these steps:

- 1 In the BOLUS HISTORY screen, select the bolus that you want to review and press ACT.

Without the Bolus Wizard feature



With the Bolus Wizard feature

If the Bolus Wizard feature calculated your bolus, more information will appear in the BOLUS DETAIL screen.



Press the down key to see the details



- 2 The details for that bolus will appear on the screen. Scroll through the details.
- 3 Exit when you are done.

Maximum bolus limit

The maximum bolus (max bolus) is a safety feature that limits the amount of insulin that can be delivered in a single bolus. The factory setting is 10.0 units. You can specify the limit from 0.0 to 25.0 units. It is important to discuss this feature with your healthcare professional to determine your maximum bolus amount.

To set the maximum bolus limit, do these steps:

- 1 Go to the MAX BOLUS SETUP screen.
Main > Bolus > Max Bolus
- 2 Set your maximum bolus limit and press **ACT**.
- 3 Your maximum bolus is set. Exit the menus.

Example 1: Max bolus

Shelby takes very small doses of insulin for her meal boluses. As a safety limit, she and her healthcare professional reset her pump with a maximum bolus of 5.0 units.

Example 2: Max bolus

David is a growing teenager. He loves to eat big meals and requires very large doses of insulin for his food. He reset his pump with a maximum bolus of 35.0 units so he can take more insulin when he needs to.

BG reminder

After you deliver a bolus you may want to check your blood glucose. The BG Reminder is an optional feature that makes the pump beep or vibrate to remind you to check your blood glucose after a bolus. However, this reminder is not available after an Easy Bolus. Your pump is set at the factory with the BG Reminder feature turned off.

When setting a bolus, if the BG Reminder is on, your pump will ask you to set up the BG Reminder Duration. This sets how long after bolus delivery you will be reminded to check your BG. This time can be from 30 minutes to 5 hours, or NONE. The BG Reminder is not available after an Easy Bolus.

- 1 Go to the BG REMINDER SETUP screen.

Main > Bolus > BG Reminder

- 2 Select **On** and press **ACT**. The BG Reminder is now enabled. Exit the menus.

Now, the next time you program a bolus, your pump will ask you for the amount of time after your bolus before you want to be reminded to check your blood glucose.

When the BG Reminder goes off, your pump will beep or vibrate and the message CHECK BG will appear on the screen. Your pump will beep or vibrate periodically until it is cleared (**ESC**, **ACT**).

When you set a BG Reminder after a bolus, the STATUS screen will show the amount of time remaining before the reminder will go off. Here, the STATUS screen indicates BG Reminder will go off in 18 minutes.

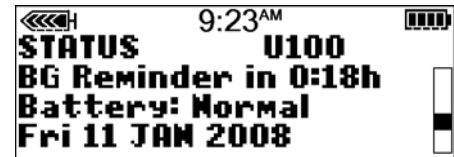

Basal

Basal insulin is required to maintain your target glucose values when you are not eating. Your healthcare professional will calculate this rate for you. Your basal insulin accounts for approximately one half of the body's total daily insulin requirements. Your pump mimics your pancreas by delivering insulin continuously over 24 hours.

You can set your insulin pump to change rates during the day to match your needs. Your needs depend on your lifestyle and insulin requirements. Some people only use one rate throughout the day, while others find they need more. Your basal rates are made up of insulin deliveries that have start and stop times. Once set, these rates make up your 24-hour basal pattern and are repeated daily.

Start and stop times

When you set your basal rate(s) in the BASAL MENU, your pump prompts you to set the start time for each basal delivery. The start time of one basal rate is the stop time of the previous rate. This gives you continuous basal insulin through a 24-hour period. For basal rate 1, the start time is midnight (12:00 a.m. or 00:00) and cannot be changed. See below for a sample graph of basal rates.

The start and stop times of basal rates for this example are:

- 12:00 a.m. (00:00) to 3:00 a.m. (3:00) for basal rate 1
- 3:00 a.m. (3:00) to 7:00 a.m. (7:00) for basal rate 2
- 7:00 a.m. (7:00) to 9:00 p.m. (21:00) for basal rate 3
- 9:00 p.m. (21:00) to 12:00 a.m. (00:00) for basal rate 4

If you need one basal insulin that starts before midnight and stops after midnight, you need to set up two basal rates. These basal rates have the same rate but different start and stop times. For example, in this graph a basal rate is needed from 9:00 p.m. to 3:00 a.m. (21:00 to 3:00) at one rate. Basal rate 1 always starts at midnight and should be set to end at 3:00 a.m. (3:00). After setting basal rates 2 and 3, rate 4 is set from 9:00 p.m. (21:00) to midnight at the same rate as basal rate 1. This gives continuous basal insulin from 9:00 p.m. to 3:00 a.m. (21:00 to 3:00) at one rate.

You cannot set a start time for one basal rate to overlap the next basal rate. The addition of a new basal rate will erase any basal rates that follow.

For best results, setting or changing your basal rate(s) should be discussed with your healthcare professional.

Your basal settings

You must program your basal settings before you can deliver basal insulin. Keep a written record of your basal settings.

It is recommended that you set your basal rates with the assistance of your healthcare professional.

If you plan to take off your pump for an extended period of time, i.e. more than a day, set the basal rate to 0.00 U/H. This will ensure that the insulin delivery records in your pump are accurate. Refer to the *If you remove your pump* section in the *The basics* chapter for more information.

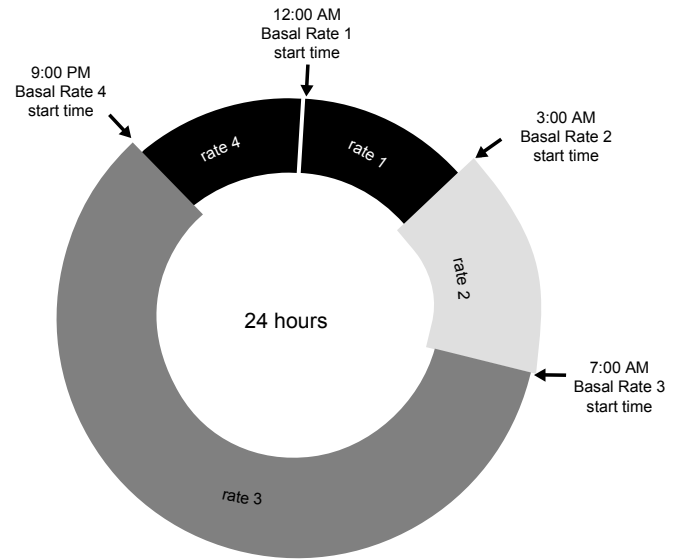

Basal programming and delivery

NOTE: You cannot make changes to your basal rate settings while a percent temp basal is active.

To set your basal rates:

- 1 Go to the SET BASAL RATE 1 screen.
Main > Basal > Set/Edit Basal
- 2 The SET BASAL RATE 1 screen flashes the basal rate in U/H.
- 3 Enter your first basal rate amount and press **ACT**.
The start time for your first basal rate is midnight (00:00 or 12:00A) and cannot be changed.
- 4 The SET START TIME 2 screen appears. The dashes under the screen name flash. The first basal rate is now set.
If you do not need a second basal rate for the day, press **ESC**. If you need to set up a second basal rate for the day, follow steps 5 and 6.
- 5 In the SET START TIME 2 screen, enter the start time for the next rate.
- 6 Press **ACT**. The SET BASAL RATE 2 screen appears. Enter the rate.
- 7 Press **ACT**. The SET START TIME 3 screen appears. The second basal rate is now set. If you do not need to set up any more basal rates for the day, press **ESC** and skip to step 9. If you need to set up more basal rates, follow steps 5 and 6 for each basal rate.
- 8 After you program your last basal rate, press **ESC**.
- 9 The BASAL RATE screen will appear. Your basal rate(s) will now deliver as programmed. Exit the menus.
- 10 When you have finished programming your pump, you can save your settings. Refer to the *User Settings* section in the *Utilities* chapter for instructions.

Current basal delivery

The STATUS screen shows your current basal information.

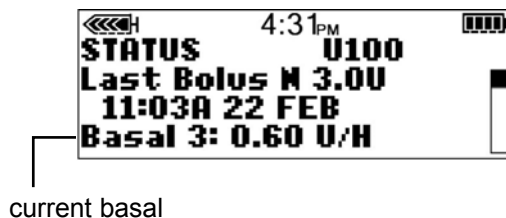

Daily basal rate(s)

The BASAL REVIEW screen shows your daily basal rates programmed for delivery from midnight to midnight. Compare your daily insulin deliveries to your blood glucose records to help you and your healthcare professional identify your optimal daily basal insulin rate(s).

To review your basal rates, do these steps:

- 1 Go to the BASAL MENU screen.
Main > Basal
- 2 Select Basal Review and press ACT.
- 3 If you do not use patterns, the STANDARD screen appears.
The delivery details for your standard basal will appear.

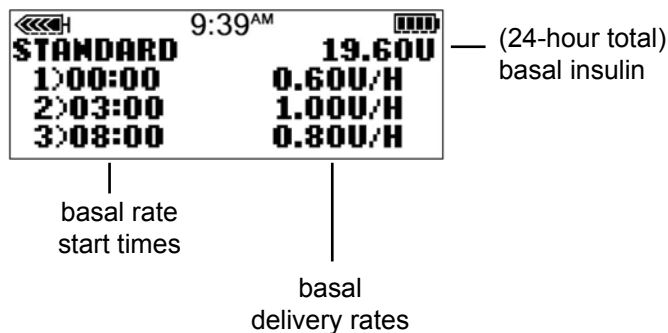

If you use patterns, the BASAL REVIEW screen appears.

The current basal pattern will be highlighted. Select the pattern you want to view. Press **ACT**.

The delivery details for that pattern will appear.

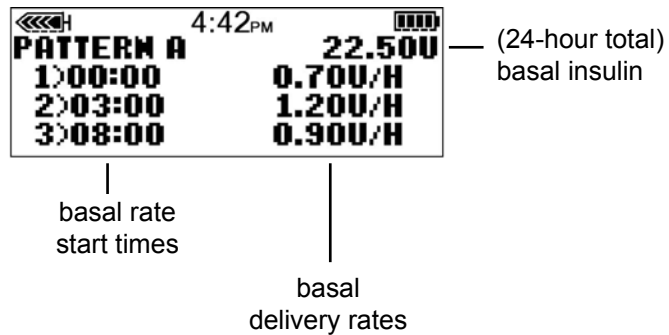

- 4 Exit the menus when you are done.

Setting the Max basal rate

Maximum (max) basal rate is a safety limit for the amount of basal insulin that is able to be delivered per hour. Your pump is sent from the factory with the max basal set to two (2.0) units per hour. It is important to determine your max basal rates with your healthcare professional. This safety feature will not allow you to program any basal rates, including patterns and temporary basal rates, that are greater than the max basal rate.

If you are setting your max basal rate after your basal rates have been set, you cannot set a max basal that is less than any of the programmed basal rates.

To set your max basal rate, do these steps:

- 1 Go to the MAX BASAL RATE screen. The maximum basal rate will be flashing.
Main > Basal > Max Basal Rate
- 2 Change the rate and press **ACT**.
- 3 Your maximum basal rate is now set. Exit the menus.

Example 1: Max Basal

Helen has a very low insulin requirement. Her highest basal rate is only 0.4 units per hour. As a safety measure, Helen's healthcare professional set her pump with a Maximum Basal Rate of 1.0 units per hour.

Example 2: Max Basal

Rusty needs large amounts of insulin to control his blood glucose levels. His new pump was delivered from the factory with a Maximum Basal Rate of 2.0 units per hour, but he needs 2.8 units per hour in the early morning. Rusty will reprogram his Maximum Basal to 3.0 units per hour to accommodate his needs.

Stopping your pump

You can stop your pump with the suspend function. **Suspend** stops all insulin delivery including the current basal and any bolus or prime deliveries that are in progress. While suspended, your pump will not deliver insulin until you resume your pump. When you resume your pump, the basal delivery will continue.

The pump will beep or vibrate about every 15 minutes on the hour to remind you that it is not delivering insulin. Example: You suspend your pump at 11:20 AM. The pump will beep/vibrate at 11:30 AM, 11:45 AM, 12:00 PM, and so on until you resume your pump (basal resumes).

When suspended, your pump is in Attention mode with a solid circle showing on the pump. When in **Suspend**, you can only resume your basal or view the STATUS screen. No other functions are available.

To suspend the pump:

- 1 Select **Suspend** from the MAIN MENU, and press **ACT**.
Main > Suspend
- 2 SUSPEND will flash on your screen. Press **ACT** to stop your pump.
- 3 The screen will show that the pump is suspended and the time that it stopped. After less than one minute, the pump will return to the HOME screen with a solid circle.
You can verify on your pump STATUS screen that your pump is suspended.

Resume pump delivery

When the pump is suspended, it defaults to the HOME screen with a solid circle.

To resume your pump and basal delivery, do these steps:

- 1 From any screen, press ACT until the RESUME screen appears. Press ACT again.



- 2 Your pump will beep once, then the HOME screen will appear without the solid circle.

NOTE: A bolus or fixed prime that was stopped by suspend will *not* restart when you resume your pump. You must reprogram and activate it to finish delivery.

Example: Suspend function

Helen is ready to eat her lunch. She has just programmed her pump to deliver a meal bolus when the phone rings. Helen wants to talk on the phone and not eat her lunch right away. She knows that if she lets the bolus continue and she does not eat her lunch soon, she may be at risk for low blood glucose. Helen suspends delivery of her pump to stop the bolus, but then resumes delivery to restart her basal insulin. When she is off the phone and ready to eat, she checks her STATUS screen to see how much insulin she received from the partially delivered bolus before she suspended her pump. She will reprogram a new bolus for the remainder of her bolus amount.

Practice:
Suspend function

- 1 **Make sure you are NOT connected to your pump while practicing.**
Program your pump to deliver a Normal bolus of 3.0 units. Once the bolus begins, stop the bolus by suspending your pump.
Remember, when you stop the bolus delivery with SUSPEND, ALL insulin delivery will stop.
- 2 Now, RESUME delivery, so that your basal insulin will continue.
- 3 Check the STATUS screen.
- 4 How much insulin did the bolus deliver before you Suspended delivery? _____.
- 5 If you wanted to take the rest of the bolus later, how much would you take to equal 3.0 units?
_____.

Practice:
Resume basal delivery after a suspend

Make sure you are NOT connected to your pump while practicing.

- 1 Give a 3.0 unit bolus now. While it is delivering, suspend the bolus.
- 2 Check here if you were able to suspend the bolus.
- 3 Now restart the pump.
- 4 Check here if you were able to restart the pump.

Starting on insulin

The Paradigm pump is intended for use with U100 insulin.

Prepare your pump for use

Before continuing with the steps in this chapter, we recommend that you watch your pump training CD-ROM and complete your pump start training.

When you are done practicing and ready to use your pump with insulin, you must make sure the time and date are correct on your pump. You must also program your settings as instructed by your healthcare professional.

You will need these items:

- Pump
- Insulin (U100)
- Paradigm reservoir and user guide
- Paradigm compatible infusion set and user guide

Filling the reservoir

Warning: Do not use the reservoir or infusion set if any liquid gets on the top of the reservoir or inside the tubing connector (as shown in the image). Liquid can temporarily block the vents. This may result in the delivery of too little or too much insulin, which can cause hypoglycemia or hyperglycemia. If any liquid gets on the top of the reservoir or inside the tubing connector, start over with a new reservoir and infusion set.

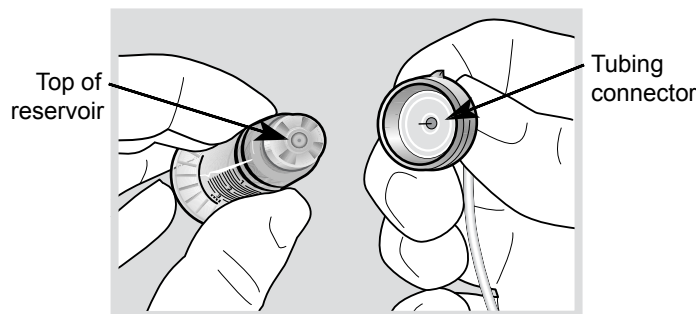

WARNING: Using cold insulin can cause air bubbles in the reservoir and tubing. If your insulin is stored in the refrigerator, allow it to reach room temperature before filling your reservoir. When filling the reservoir, take care to remove air bubbles.

CAUTION: Insulin comes in different vial types, depending on your country. If your vial is different than the one described in the User Guide, consult with your healthcare professional on how to fill your reservoir.

1 Remove reservoir from package. Make sure plunger rod is fully extended.

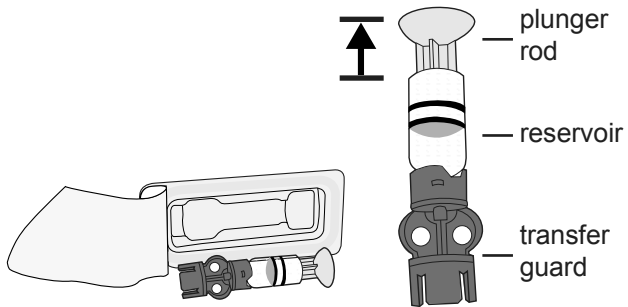

2 Swab vial with alcohol (not shown).

3 Making sure you do not push down on the plunger, press the transfer guard onto the vial.

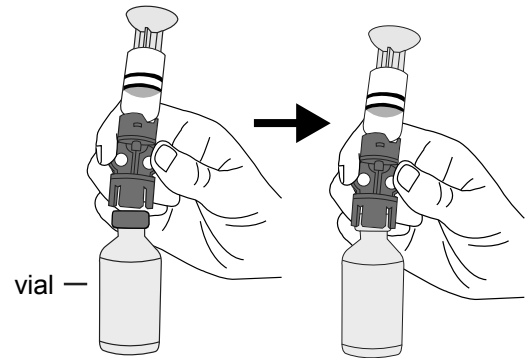

4 Push down on the plunger to pressurize the vial. Hold down the plunger rod.

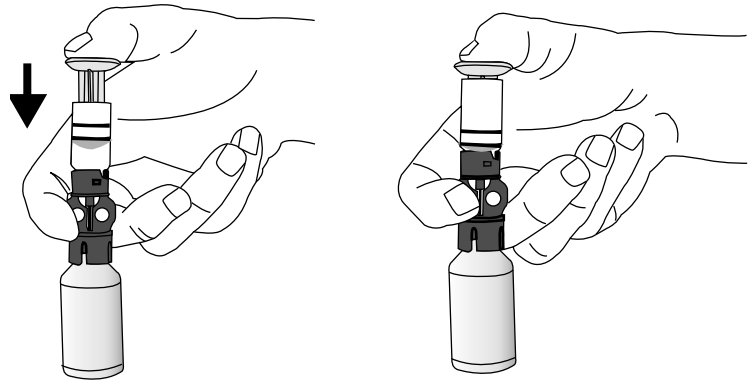

5 While still holding the plunger rod, flip the vial over so the vial is on top, slowly pull down on the plunger to fill the reservoir.

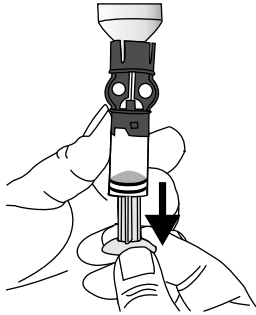

6 Gently tap the side of the reservoir to make any air bubbles rise to the top of the reservoir.

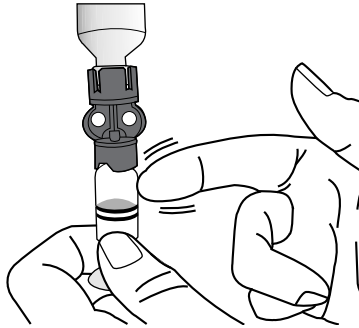

7 Slowly push up on the plunger just enough to remove any air bubbles from the reservoir.

8 Slowly pull down on the plunger to fill the reservoir to the number of units desired.

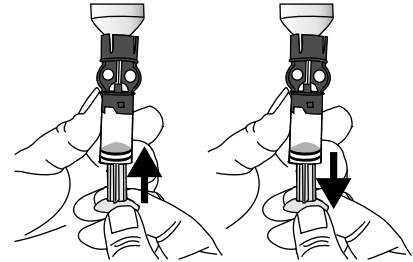

9 To avoid getting liquid on the top of the reservoir, flip the vial over so that it is upright. Turn the reservoir counter-clockwise, then pull straight up to remove the reservoir from the transfer guard.

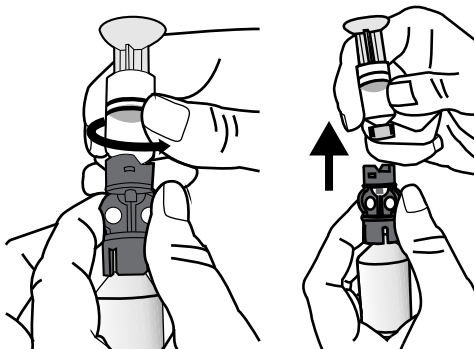

10 Place the tubing connector onto the reservoir. Turn the connector clockwise, pressing gently against the reservoir until you feel it slide in. Push in and continue turning until the reservoir and the connector lock with a click.

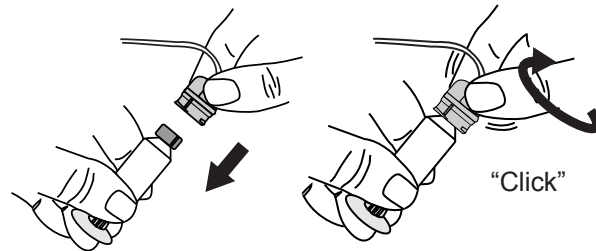

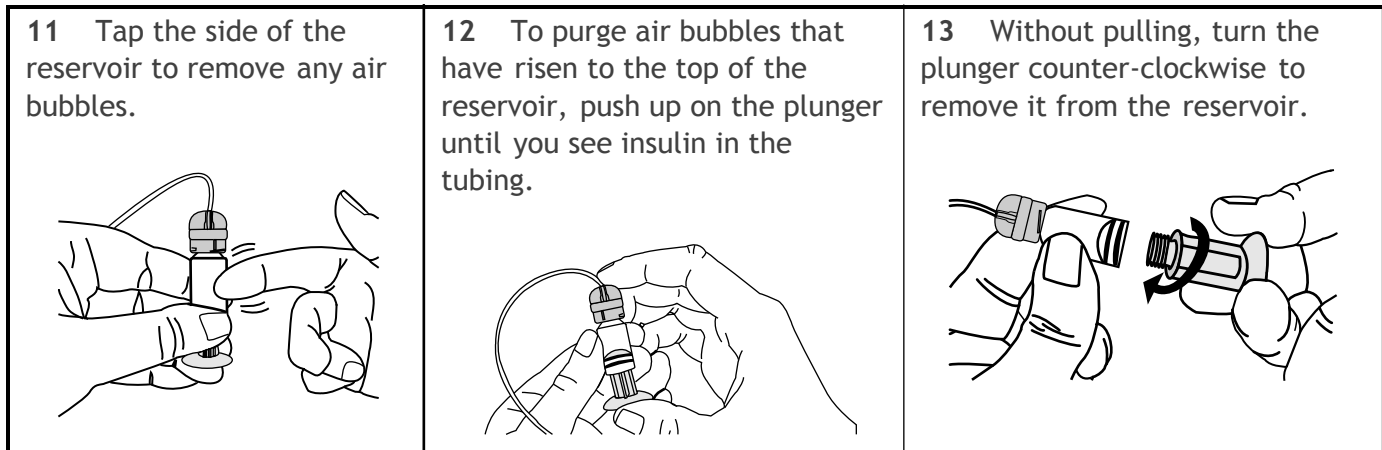

Changing your infusion set

Removing the reservoir

Each time you remove and replace a reservoir in your pump, you have to rewind your pump, and fill the infusion set with insulin.

- 1 Remove the entire infusion set from your body.
- 2 If attached, remove the activity guard.
- 3 Turn the tubing connector half-turn counter clockwise, then pull the reservoir and connector out from the pump.

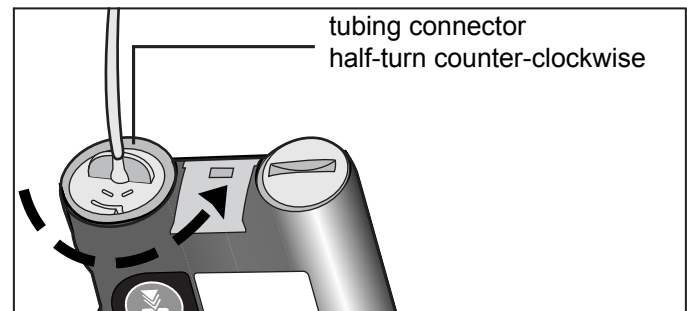

- 4 Safely dispose of the used reservoir and infusion set item in a sharp's container.
- 5 You must now rewind your pump as described in the next section.

Rewinding your pump

Before you continue, make sure the infusion set is NOT connected to your body and the reservoir is NOT in the pump.

WARNING: Make sure the infusion set is disconnected from your body before you rewind your pump or fill the infusion set tubing. Never insert the reservoir into the pump while the tubing is connected to your body. Doing so could result in an accidental infusion of insulin.

- 1 If you removed your reservoir and are replacing it, go to the REWIND screen.
Main > Prime > Rewind
- 2 In the REWIND screen, press **ACT** to start the rewind process. The REWINDING screen will appear while the pump rewinds.
- 3 After the pump rewinds the PREPARING TO PRIME screen will appear.
If you are practicing:
 - a. Do **NOT** insert the reservoir in your pump. Make sure the red shipping cap is installed in the reservoir compartment as shipped.
 - b. Press **ACT**, then continue with the manual prime instructions described in the *Manual prime* section of this chapter.

If you are **not practicing**, continue to the next section to insert the reservoir in your pump.

Inserting the reservoir in your pump

If your reservoir is already inserted in your pump, continue to the next section.

You must do these steps in the order described. If you are practicing, do **NOT** insert the reservoir in your pump.

CAUTION: You must rewind your pump before installing a new reservoir. As part of the pump's function, it calculates the reservoir volume. To ensure correct volume calculations, your pump has been designed to require a rewind before you insert your reservoir.

- 1 If you are using the pump for the first time, remove the red shipping cap from the reservoir compartment.

WARNING: Do not insert the reservoir in the pump if you did not rewind. Doing so could result in inaccurate insulin delivery.

Never insert the reservoir into the pump while the tubing is connected to your body. Doing so could result in an accidental infusion of insulin.

- 2 Insert the reservoir into the top of the pump case.

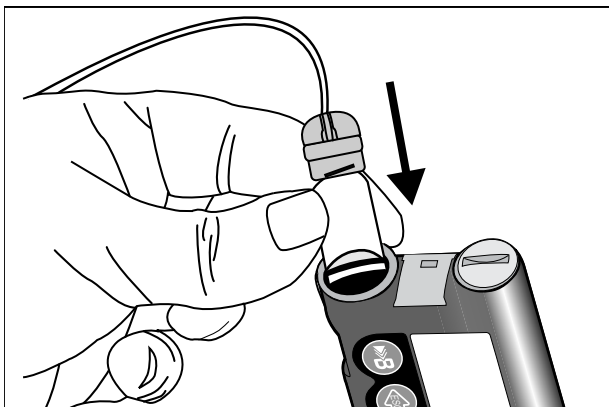

- 3 Turn the tubing connector approximately 1/2 -turn clockwise until the connector is seated. The tubing connector should be aligned horizontally with the pump case as shown here.

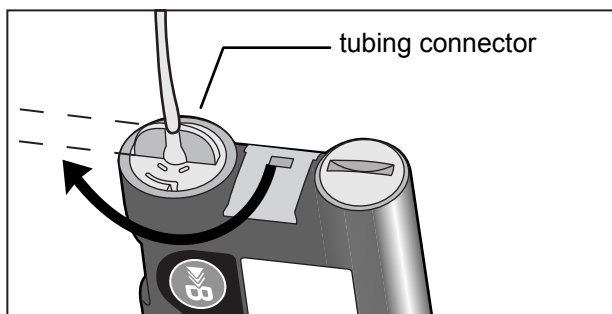

- 4 Attach the activity guard, if desired.
5 You must now do a manual prime as described in the next section.

Manual prime

Manual prime fills the infusion set tubing with insulin before you attach it to the infusion site. Manual prime is only available after you rewind your pump.

WARNING: Make sure that the infusion set is disconnected from your body before you press ACT to prime the pump. Never insert the reservoir into the pump while the tubing is connected to your body. Doing so could result in an accidental infusion of insulin.

- 1 After you rewind your pump, the PREPARING TO PRIME screen appears. The pump may automatically return to the HOME screen while you install the reservoir. Press ACT to return to the PREPARING TO PRIME screen.
- 2 Press and hold ACT to start the prime. The pump will beep six times when the prime starts.
- 3 While you hold ACT, the pump will again beep six times when the screen begins counting the prime units being used.
- 4 Continue to hold ACT until insulin droplets form on the tip of the infusion set needle, then release. Make sure there are no bubbles in the tubing.

WARNING: If the PRIMING-HOLD ACT screen does not display, do NOT insert the infusion set in your body. Please contact your local representative for assistance.

If your manual prime uses more than 30U insulin, the pump will show the following screen: IS PRIMING COMPLETE? When you get this message, do the following:

- a. **Make sure you are not connected to the pump.**
 - b. Read the message on the screen, then press ESC, ACT to clear.
 - c. If your manual prime is complete (you see droplets on the tip of the infusion set needle), press ESC and continue to step 5.
- 5 Press ESC. Your manual prime is complete.
 - 6 You can now insert the infusion set into your body as described in the next section.

Inserting the infusion set

WARNING: While the infusion set is connected to your body, do not unscrew and retighten the tubing connector on the reservoir.

After you complete all of the following, you will be ready to insert the infusion set into your body:

- fill your reservoir
- rewind your pump
- insert the reservoir into pump
- and fill the infusion set with insulin

Shown here are the best body areas (shaded) for infusion set insertion. Avoid the 2-inch (5.0 cm) area around the navel.

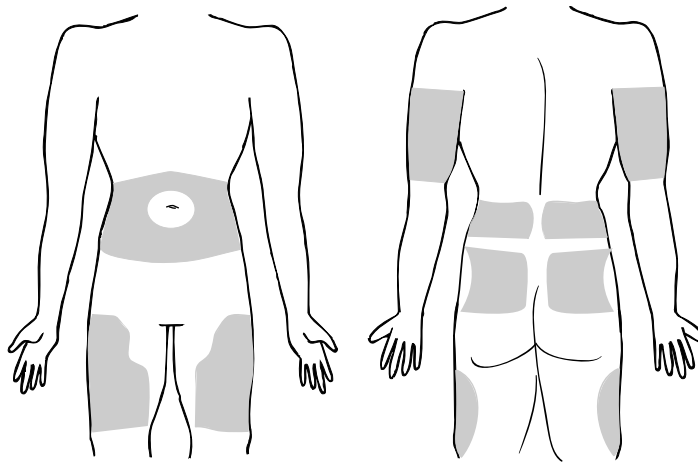

It is important that you change your infusion set every 2-3 days. Be sure to rotate the infusion sites so that they do not become overused. The abdominal area is the most common site for set insertions because absorption is very consistent. To keep abdominal sites healthy, some people find it helpful to use a visual scheme to help them rotate their infusion sites in an organized way. Here are two commonly used methods. For maximum effectiveness, use both methods, alternating between them:

- Visualize an imaginary clock drawn on your abdomen surrounding your belly button. Rotate infusion sites by starting at 12 o'clock and then rotating the site clockwise to 3 o'clock, 6 o'clock, etc.

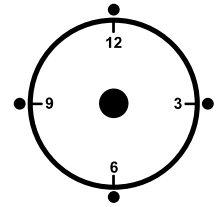

- Imagine a letter M or a letter W on either side of your belly button. Start at the end of one letter and proceed through the letter, rotating to each intersection in turn.

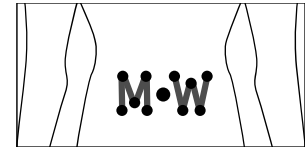

Medtronic Diabetes offers a number of different infusion sets for your pump. Instructions for the Quick-set® begin on the next page as an example. Always refer to the instructions that shipped with your infusion set.

After your infusion set is inserted, see the next section to prime your pump.

Quick-set infusion set (with Quick-serter®)

Always refer to the instructions that shipped with your infusion set.

1 Wash your hands.

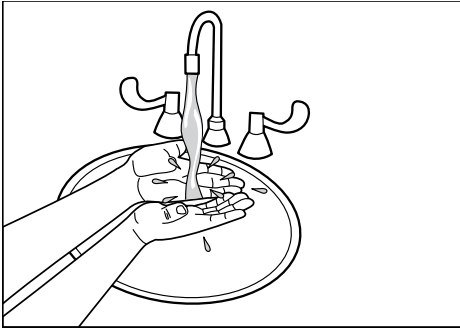

2 Clean the infusion site. Let it air dry.

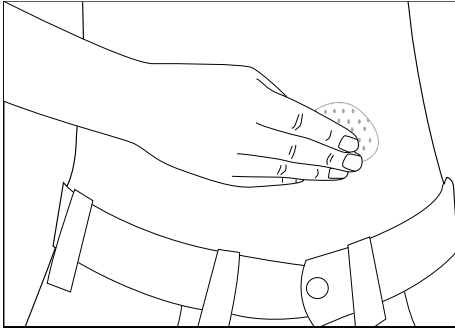

3

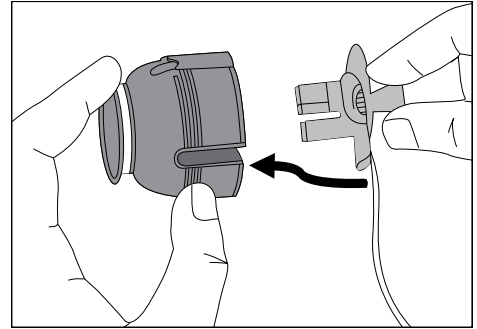

4

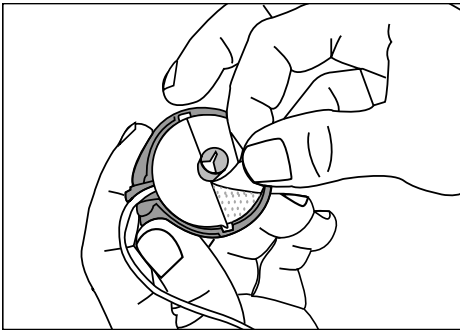

5

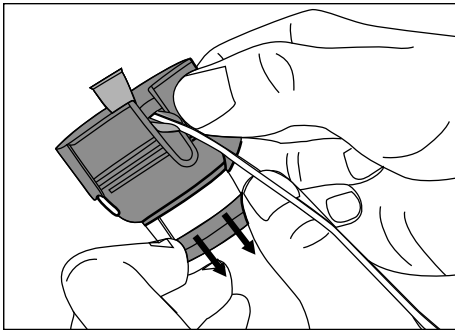

6

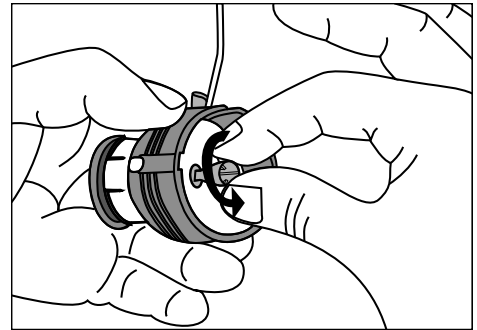

7

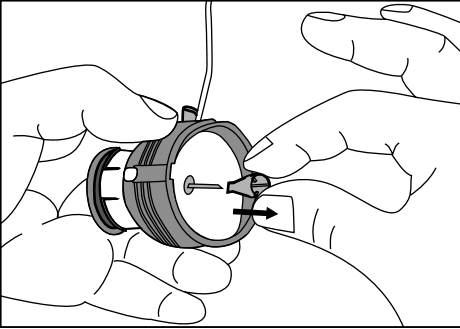

8

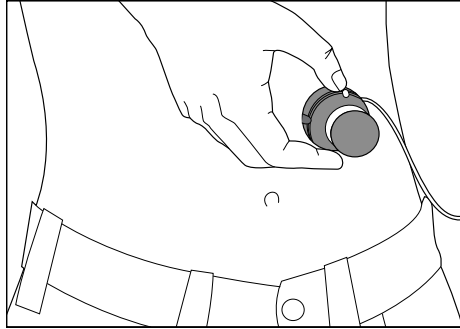

9

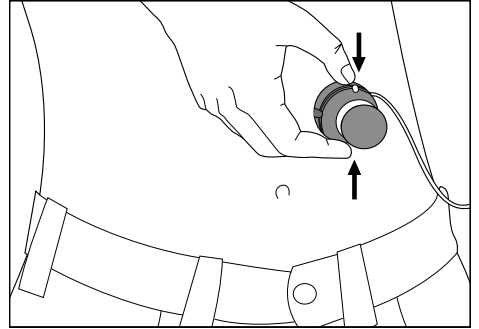

10

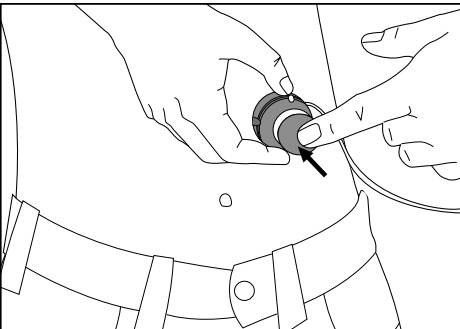

11

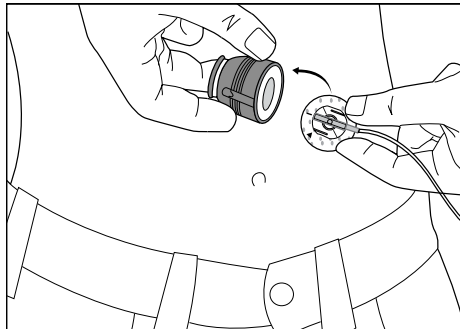

12

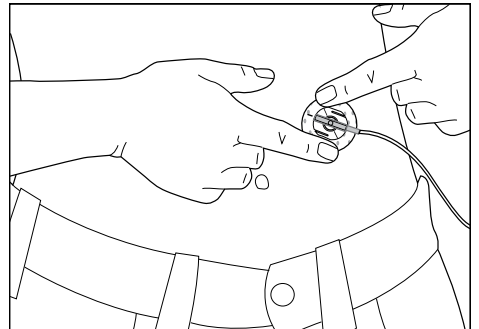

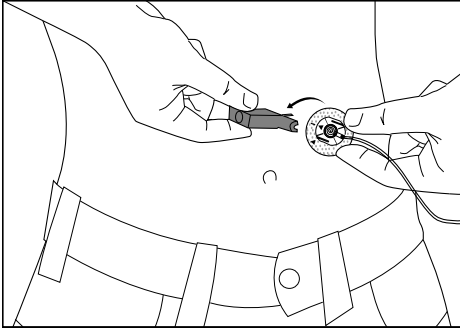

Fixed prime

A fixed prime fills the soft cannula with insulin and is required after the infusion set is inserted into your body and the introducer needle removed. The prime amount depends on your infusion set type, so read your infusion set instructions for the fixed prime amount. A fixed prime is also required before reconnecting the tubing to the infusion set to make sure that all air is removed from the tubing.

- 1 Go to the PRIME MENU screen.
Main > Prime
- 2 Select **Fixed Prime** and press **ACT**.
- 3 In the FIXED PRIME screen, enter the insulin amount for your infusion set type, then press **ACT**.
- 4 After the prime begins, the PRIME DELIVERY screen will count the units as they are delivered. The pump will beep after priming is complete.

Prime history

Do these steps to see a list of the delivered primes.

- 1 Go to the PRIME HISTORY.
Main > Prime > Prime History
- 2 Scroll through the list of prime deliveries. The letter F at the end of the text line indicates a fixed prime.
The letter M indicates a manual prime. Exit the menus.

Disconnecting Quick-set

The Quick-set allows you the freedom to temporarily disconnect from your pump without removing the infusion set from your body.

1 Hold the side grips of the connector part with your fingers.

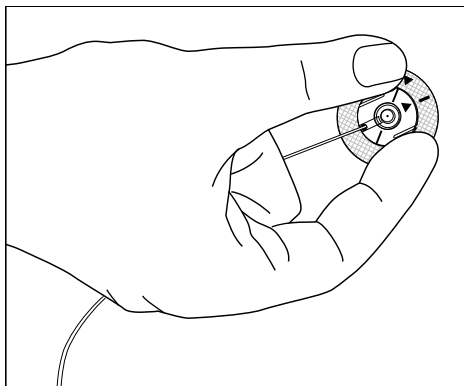

2 Twist the connector counter-clockwise.

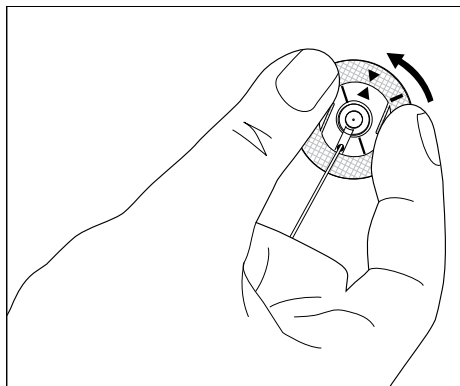

3 Remove the connector from the site.

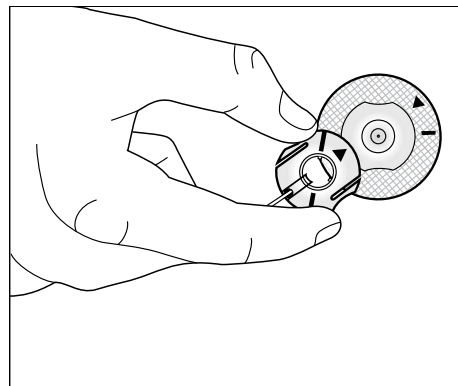

Reconnecting Quick-set

A fixed prime is used before reconnecting the infusion set to your body to ensure that insulin has filled the infusion set. See the instructions in this chapter.

Place the connector part (flat-side facing down) on the infusion set until it is fully seated. Do not grip the connector part by the flat side-grips.

1

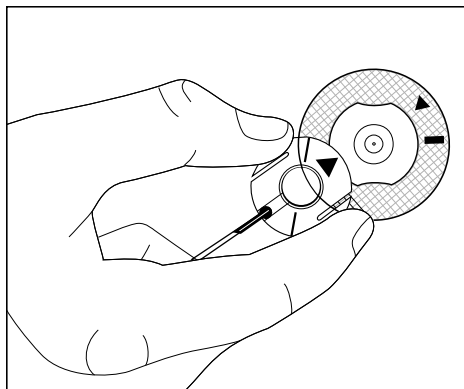

2

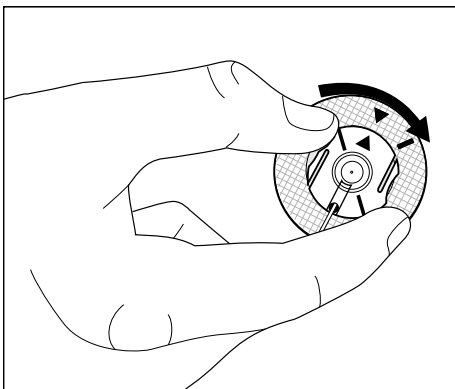

3

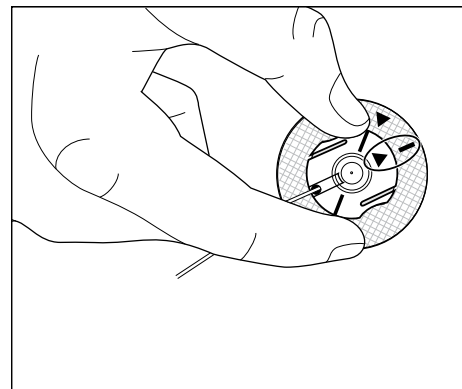

Record keeping for diabetes management

Now that you are using the pump, we will be asking you to test your blood glucose regularly. The information from your blood glucose journal is your healthcare professional's only method of making adjustments in your pump settings. It is important to test often and write down your blood glucose readings, the food you eat, any exercise you perform and any other notes to explain your blood glucose results.

You must test at the recommended times and any other time that you feel your blood glucose is high or low. Be sure to include your meal boluses, correction boluses, the amount of carbohydrate you eat, basal rate and any other information that will be helpful in assisting your healthcare professional in adjusting your pump settings.

It is very important to look at your blood glucose readings as feedback regarding your diabetes management, not as statements about you or your self-worth. Try not to have an emotional reaction to the numbers and do not judge them too harshly. You will soon learn how to modify the numbers easily and precisely through insulin pump therapy.

Test at least 4-6 times a day.

These are the recommended times to test to determine control:

- Overnight (occasionally, at approximately 2 - 3:00 AM)
- Pre-breakfast (fasting)
- Post-breakfast (approximately 2 hours after eating)
- Pre-lunch
- Post-lunch (approximately 2 hours after eating)
- Pre-dinner
- Post-dinner (approximately 2 hours after eating)
- Bedtime
- Before driving

Determining your pump settings

Your healthcare professional will use your daily blood glucose journal records to program your pump. It is very important to keep good records during the first weeks after you start on pump therapy. Not only must you record your blood glucose readings, but it will be important to eat regularly scheduled meals and to keep your activity as consistent as possible.

Until you and your healthcare professional determine the pump settings that will work best for you, it is important to eat meals for which it is easy to count the carbohydrates. After your correct basal rate is determined, you will be able to experiment with varied food choices and amounts.

After you and your healthcare professional are satisfied with your initial pump settings, you may begin to experiment with different food choices, meal times and exercise schedules.

Using the Bolus Wizard feature

What is it?

Bolus Wizard is a feature that calculates an estimated bolus to support your food intake or to correct high blood glucose. You need the following information:

Carbohydrate counting

You need to know how which foods contain carbohydrates and how to count these.

Your blood glucose reading

You need to know your blood glucose (BG) reading. When using the Bolus Wizard feature, the pump can work with blood glucose meter powered by MWT1 technology to automatically receive your blood glucose reading. MWT1 is the wireless RF technology that is used to transmit information from the meter to the pump. You can program your pump to automatically receive your BG reading from this meter. All meters referenced in this user guide are blood glucose meters supported by MWT1 technology. The *Meter option* section in this chapter has more information. If you are not using this meter, you will manually enter your blood glucose.

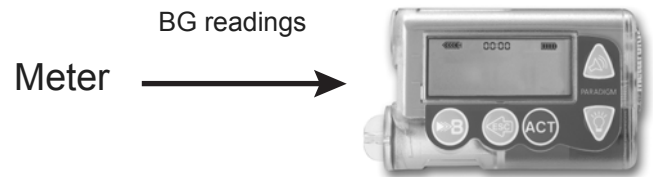

Your personal Bolus Wizard feature settings

In addition to your blood glucose reading and/or your food entry, the Bolus Wizard feature uses personal settings that you program into the pump. (For instructions see the *How to program the Bolus Wizard feature* section in the *Using the Bolus Wizard feature* chapter.)

- carb units (grams or exchanges)
- carb ratios (in carbohydrate grams/unit of insulin or insulin units/carb exchanges)
- BG units (mg/dL or mmol/L)
- insulin sensitivity
- target blood glucose range
- active insulin time (hours)

Get this information from your healthcare professional, and, for best results, talk to your healthcare professional before making any changes. Keep a record of your settings in the following *Bolus Wizard feature settings* table:

Bolus Wizard feature settings	
Information	Setting
Carb units:	_____ grams or _____ exchanges
<p>Carb ratios: Bolus Wizard feature uses this for your food bolus calculations. If you count carbs: this ratio is the amount of carbohydrate grams covered by one (1) unit of insulin. range: 3 - 150 grams/unit</p> <p>If you count exchanges: this ratio is the amount of insulin you need to cover one (carb) exchange. range: 0.1 - 5.0 units/exchange</p> <p>NOTE: Your carb ratios may vary throughout the day. Your pump allows you to program up to eight (8) different carb ratios.</p>	<p>#1: _____</p> <p>#2: _____</p> <p>#3: _____ (additional settings, if needed)</p> <p>#4: _____</p> <p>#5: _____</p> <p>#6: _____</p> <p>#7: _____</p> <p>#8: _____</p> <p>start time (midnight)</p>

Bolus Wizard feature settings		
Information	Setting	
BG units: (how you measure your blood glucose)	_____ mg/dL or _____ mmol/L	
<p>Insulin sensitivity: This ratio is used for your correction bolus calculations. This ratio is the BG units reduced by 1.0 unit of insulin. range: 10 - 400 mg/dL or 0.5 - 22.2 mmol/L</p> <p>NOTE: <i>Your insulin sensitivity may vary throughout the day. Your pump allows you to program up to eight different insulin sensitivities.</i></p>	<p>BG units reduced / 1 unit of insulin</p> <p>#1: _____</p> <p>#2: _____</p> <p>#3: _____ (additional settings, if needed)</p> <p>#4: _____</p> <p>#5: _____</p> <p>#6: _____</p> <p>#7: _____</p> <p>#8: _____</p>	<p>start time (midnight)</p>

Bolus Wizard feature settings	
Information	Setting
<p>BG target range: If your current blood glucose is above the BG Target Range, the Bolus Wizard feature will calculate a correction dose. If your current blood glucose is below the BG Target Range, the Bolus Wizard feature will calculate a negative correction and subtract it from your food bolus.</p> <p>range: 60 - 250 mg/dL or 3.3 - 13.9 mmol/L</p> <p>NOTE: Your pump will allow you to program up to eight different BG target ranges.</p>	<p>#1: _____ (midnight)</p> <p>#2: _____</p> <p>#3: _____ (additional settings, if needed)</p> <p>#4: _____</p> <p>#5: _____</p> <p>#6: _____</p> <p>#7: _____</p> <p>#8: _____</p>
<p>Active insulin time: The Bolus Wizard feature uses this time to calculate the active insulin in your system. Use your healthcare professional's recommendation for the active insulin time that best represents the insulin type you use and your physiological insulin absorption rate.</p> <p>range: 2-8 hours</p>	<p>Number of Hours: _____</p>

How the Bolus Wizard feature works

- 1 If you want your current blood glucose to be factored in, enter your BG Reading.
 - automatically from the meter (refer to the *Meter option* section of this chapter);
or
 - manually by selecting the  button.
- 2 If you are going to eat, enter your food amount in grams or exchanges.
- 3 The Bolus Wizard feature will calculate a bolus for you. An ESTIMATE DETAILS screen will appear with your estimated total bolus amount.

Bolus Wizard warnings

High or low blood glucose levels

If your blood glucose in the ENTER BG screen is not in the range of 70 to 250 mg/dL (3.9 to 13.9 mmol/L), the Bolus Wizard feature will give you a warning. Either a LOW BG or HIGH BG screen appears. Read the instructions, then press **ACT** or **ESC** to clear the message. You can then continue programming to deliver your bolus.

About maximum delivery

Bolus Wizard feature will not deliver more than the limit set for your maximum bolus. If the Bolus Wizard feature calculates a bolus amount that is larger than your max bolus limit setting, the message, MAX BOLUS EXCEEDED will appear. If this happens, do these steps:

- 1 In the MAX BOLUS EXCEEDED screen, press **ACT** to continue your bolus programming. The EST : MAX screen appears with the estimated and maximum bolus amounts. Continue to the next step.
If you do not want to continue, press **ESC** to cancel and the screen will return to the ENTER BG screen.
- 2 In the EST : MAX screen, press **ACT** again to continue your bolus programming.
- 3 The SET BOLUS screen appears with the maximum bolus amount flashing. Enter the bolus amount. This amount cannot be more than the max bolus amount. Press **ACT**.
- 4 The BOLUS DELIVERY screen appears showing the insulin units being delivered.
- 5 The pump will beep/vibrate after it has completed the insulin delivery.

How to program the Bolus Wizard feature

You need your personal settings from the Bolus Wizard feature settings table to setup the Bolus Wizard feature. Your Bolus Wizard feature settings are programmed in the EDIT SETTINGS screen.

Main > Bolus > Bolus Wizard Setup > Edit Settings

Once the settings are programmed, you do not have to program them again unless the values change. After you program one setting, the screen will automatically go to the next required setting. After you program all your settings, review them as described in this section to make sure they are set correctly.

Instructions for programming the Bolus Wizard feature settings are in the next paragraphs. Program your settings in the order described to make sure you program all the settings. If you have not completed setting up all of the required settings, MISSING INFO screen appears. It lists the required settings for this feature. You must program the listed settings before you can use the Bolus Wizard feature.

Turning on the Bolus Wizard feature

- 1 Go to the EDIT SETTINGS screen.

Main > Bolus > Bolus Wizard Setup > Edit Settings

- 2 The EDIT SETTINGS screen appears with **Wizard: Off** selected. Press **ACT**.
- 3 The WIZARD ON/OFF screen appears. Select **On**, then press **ACT**.
- 4 The EDIT SETTINGS screen appears, showing that the wizard is now turned on. You are now ready to select your carb units.

Selecting the Carb units

The carb unit setting lets the pump know which way to count your carbohydrates (grams or exchanges). Any time you make changes to the carb units, you must also reprogram the carb ratios. Refer to the *Bolus Wizard feature settings* table in this chapter for your carb ratio settings.

- 1 Make sure the EDIT SETTINGS screen is open.

Main > Bolus > Bolus Wizard Setup > Edit Settings

- 2 Select **Carb Units**, then press **ACT**.
- 3 The CARB UNITS screen appears. Select **Grams** or **Exchanges**, then press **ACT**.
- 4 The EDIT SETTINGS screen shows the carb units you selected. You are now ready to set your carb/exchange ratios.

Setting the Carb/Exch ratios

Your pump allows you to set up to eight Carb/Exch ratios because this ratio may vary throughout the day. Your healthcare professional may only have you program one or two carb ratios when you first start using the Bolus Wizard feature.

- 1 Make sure the EDIT SETTINGS screen is open.
Main > Bolus > Bolus Wizard Setup > Edit Settings
- 2 Select **Carb Ratios**, then press **ACT**.
- 3 The SET CARB RATIO 1 (if you are using grams) or SET EXCH RATIO 1 (if using exchanges) screen appears. The default ratio flashes on the screen.
- 4 Set your first ratio, then press **ACT**. Carb ratio values are normally between 5-50 grams/u or 0.3-3.0 u/exch. If your ratio value is outside the range, a warning message will appear on the screen. This message warns that the entered carb ratio is valid but outside the usual range. Press **ESC** to correct or **ACT** to continue.
The start time for your first ratio is midnight and cannot be changed.
- 5 The SET START TIME 2 screen appears. The dashes under the screen name flash. The first Carb Ratio or Exchange Ratio is now set.
If you do not need a second ratio, press **ESC** and skip to the next section. If you need to set up another ratio, follow steps 6 through 9.
- 6 In the SET START TIME 2 screen, enter the time of the day you want this ratio to become active.
- 7 Press **ACT**. The SET CARB RATIO 2 screen appears.
- 8 The default ratio flashes. Select your ratio.
- 9 Press **ACT**. The SET START TIME 3 screen appears. The second carb or exchange ratio is now set.
- 10 If you do not need to set up any more ratios, press **ESC**. If you need to set up more ratios, repeat steps 6 through 9 above for each ratio.
You are now ready to set up the BG units.

Setting the BG units

You can select **mmol/L** or **mg/dL** as your Blood Glucose Unit (measurement type). If you make changes to your BG settings, you must reprogram your insulin sensitivity and BG targets.

- 1 Make sure the EDIT SETTINGS screen is open.
Main > Bolus > Bolus Wizard Setup > Edit Settings
- 2 Select **BG Units**, then press **ACT**.

- 3 The BLOOD GLUCOSE UNITS screen displays. Select **mmol/L** or **mg/dL**, then press **ACT**.
- 4 The EDIT SETTINGS screen shows the BG units you selected. You are now ready to set your insulin sensitivity.

Insulin sensitivity

Your insulin sensitivity is the amount your blood glucose (BG) level is reduced by one unit of insulin. This value is used to calculate a suggested insulin dose to correct a high BG. Because this sensitivity may vary throughout the day, your pump lets you set up to eight sensitivity settings. Your healthcare professional may only have you program one or two insulin sensitivities when you first start using the Bolus Wizard feature. Record your settings in the *Bolus Wizard feature settings* table in this chapter.

Insulin sensitivity values are normally between 20 - 100 mg/dL (1.1 - 5.6 mmol/L). If your value is outside this range, a warning message will appear on the screen.

- 1 Make sure the EDIT SETTINGS screen is open.

Main > Bolus > Bolus Wizard Setup > Edit Settings

- 2 Select **Sensitivity**, then press **ACT**.
- 3 The INS SENSITIVITY 1 screen appears. The default sensitivity value flashes on the screen.
- 4 Set the value for your first insulin sensitivity setting, then press **ACT**.
The start time for your first insulin sensitivity is midnight and cannot be changed.
- 5 The SET START TIME 2 screen appears. The dashes under the screen name flash. The first insulin sensitivity is now set.
If you do not need a second insulin sensitivity, press **ESC** and skip to the next section. If you need to set up another insulin sensitivity, follow steps 6 through 9.
- 6 In the SET START TIME 2 screen enter the time of the day you want this insulin sensitivity to become active.
- 7 Press **ACT**. The INS SENSITIVITY 2 screen appears.
- 8 The default sensitivity value flashes. Select the value for this insulin sensitivity.
- 9 Press **ACT**. The SET START TIME 3 screen appears. The second insulin sensitivity is now set.
- 10 If you do not need to set up any more insulin sensitivities, press **ESC**. If you need to set up more insulin sensitivities, repeat steps 6 through 9 above for each insulin sensitivity.
You are now ready to set up the BG target.

Setting the BG targets

The BG Target setting allows you to set glucose targets. The Bolus Wizard will use these targets to calculate a correction dose. Because your targets may vary throughout the day, your pump allows you to set up to eight BG targets each day. If you want to set just one target value, instead of a range, set both the low and high values to the same number.

If your current BG is above the BG Target range, the Bolus Wizard feature may calculate a correction dose. A correction dose will be enough insulin to bring your BG down to your current high end of the BG Target range. If your current BG is below the BG Target range, the Bolus Wizard may calculate a negative correction and subtract it from your food bolus. This will bring your BG to the low end of your BG Target range.

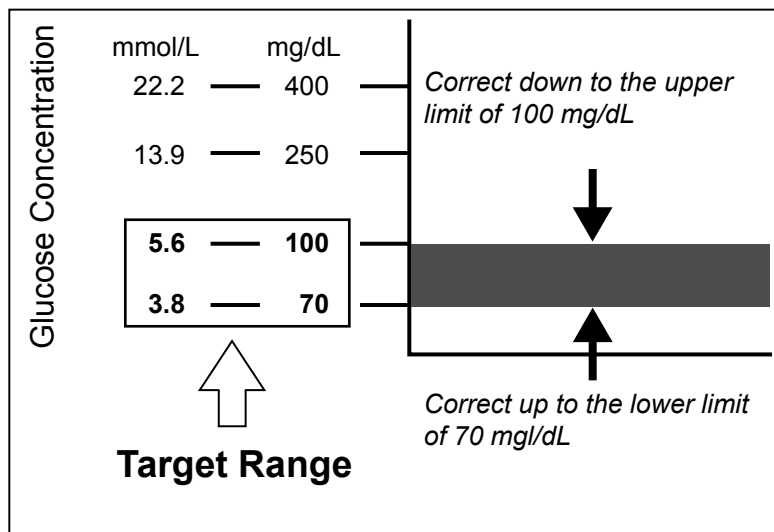

Pumps are sent from the factory with default BG target range of 100-100 mg/dL (5.6-5.6 mmol/L).

- 1 Make sure the EDIT SETTINGS screen is open.

Main > Bolus > Bolus Wizard Setup > Edit Settings

- 2 Select **BG Target**, then press **ACT**.
- 3 The **TARGET RANGE 1** screen appears. The low end of your BG target range flashes on the screen.
- 4 Set the BG target, then press **ACT**.
- 5 The high end of your BG target range flashes on the screen. Enter the BG target, then press **ACT**. The start time for your first BG target is midnight and cannot be changed.
- 6
 - a. If you adjust your BG Targets outside of 90-140 mg/dL (5.0-7.8 mmol/L), the pump screen displays a warning that the values are acceptable but outside normal range. Press **ESC** to change your BG target or press **ACT** to set this range.
 - b. If your BG target is within 90-140 mg/dL (5.0-7.8 mmol/L), the **SET START TIME 2** screen appears. The dashes under the screen name flash. The first BG target range is now set. If you do not need a second BG target range, press **ESC** and skip to the next section. If you need to set up another BG target range, follow steps 7 through 11.

- 7 In the SET START TIME 2 screen enter the time of the day you want this BG target range to become active.
- 8 Press **ACT**. The TARGET RANGE 2 screen appears.
- 9 The low end of your BG target range flashes on the screen. Set the BG target, then press **ACT**.
- 10 The high end of your BG target range flashes on the screen. Enter the BG target, then press **ACT**.
- 11 The SET START TIME 3 screen appears. The second BG target range is now set.
- 12 If you do not need to set up any more BG target ranges, press **ESC**. If you need to set up more BG target ranges, repeat steps 7 through 11 above for each one.
You are now ready to set up the Active insulin time.

About active insulin

Active insulin is the bolus insulin that has already been delivered to your body, but has not yet been used. The pump considers your active insulin time setting in determining any active insulin still in your body from prior boluses. This may help prevent hypoglycemia caused by over-correcting for high blood glucose.

The Bolus Wizard feature automatically tracks active insulin for you, based on your active insulin time, and subtracts the appropriate amount when your blood glucose is above your target range. The details will appear in the ESTIMATE DETAILS screen during the bolus programming steps.

Your Paradigm pump is shipped from the factory with an active insulin time setting of six hours, which most closely matches the published scientific data. If your healthcare professional prescribes a different time for you, the active insulin time setting can be adjusted in the Bolus Wizard menu in one-hour increments from two to eight hours.

For more details about active insulin, see the *Bolus Wizard feature specifications* section in the *Pump specifications chapter*.

CAUTION: If you give yourself insulin by using a syringe, the Bolus Wizard feature will not be able to correctly determine the active insulin in your system. Consult with your healthcare professional on how long you need to wait after a manual injection before you can rely on the active insulin calculation of your Bolus Wizard feature.

Active insulin time

The active insulin time setting lets the pump know which active insulin time to use in calculating the amount of active insulin to subtract before estimating a bolus. Your healthcare professional should determine the active insulin time that is best for you.

To set the Active insulin time, do the following steps:

- 1 Make sure the EDIT SETTINGS screen is open.
Main > Bolus > Bolus Wizard Setup > Edit Settings
- 2 Select **Active Ins Time**, then press **ACT**.
- 3 The **ACTIVE INS TIME** screen appears. The default time of six hours flashes on the screen.
- 4 Set the number of hours for the active insulin time, then press **ACT**.
- 5 The EDIT SETTINGS screen shows the new Active insulin time setting. You have now completed the Bolus Wizard setup. Press **ESC** or wait to see the message: **Bolus Wizard setup is complete**.

Review your Bolus Wizard feature settings

Check your Bolus Wizard feature settings in the REVIEW SETTINGS screen. If necessary, compare this information with your information in the Bolus Wizard feature settings table.

- 1 Go to the REVIEW SETTINGS screen.
Main > Bolus > Bolus Wizard Setup > Review Settings
- 2 Scroll through the text to view your Bolus Wizard settings.
- 3 Exit the menus when you are done.

Meter option

You can set up your pump to automatically receive your blood glucose reading from the linked meter. This meter may not be available in all countries. Check with your local Medtronic Diabetes representative. Your pump is set at the factory with the

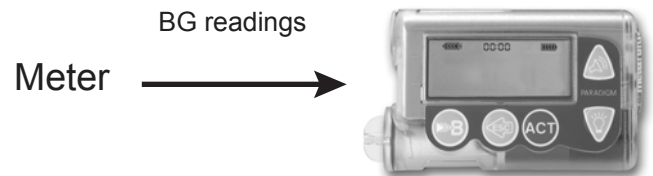

meter option turned off. Programming your meter ID links your pump to the meter. If you do not link the meter to your pump, you will enter your blood glucose readings manually. Each meter has its own unique ID. You can link up to three meters to your pump.

When the pump is idle (at the HOME screen), it will beep or vibrate when it receives a blood glucose reading from the meter. The reading will appear on the pump screen.

NOTE: *The use of RF (radio frequency) devices with the pump reduces pump battery life.*

You have to turn on the meter option to add, delete or review the meter ID(s) programmed in your pump. The meter ID is the serial number printed on the back of the meter. See the user guide that came with your meter for detailed information on how to use it.

Meter rules

If you want your pump to communicate with the meter, the following conditions must apply:

- 1 The meter option must be turned on and programmed. Refer to the instructions in this section.
- 2 Your pump must be within 4 feet (1.2 meters) of your meter to receive the blood glucose reading.
- 3 The pump cannot have a LOW BATTERY alert condition.
- 4 When programming a bolus, the blood glucose measurement from the meter will appear as the default blood glucose value on the ENTER BG screen. The pump will not display a reading that is older than 12 minutes on the ENTER BG screen.
- 5 Do not use the RF meter to send your blood glucose readings to the pump while onboard aircraft. Manually enter your blood glucose.

CAUTION: The pump will not receive signals from the meter while it has a LOW BATTERY condition. To ensure the meter communicates with the pump, make sure the pump does not have a low battery. (Replacing the low battery with a new battery will restore meter-pump communication.)

Add, delete, review meter IDs

The meter programming screens are very similar to those for the remote control. Make sure to select **Meters** in the DEVICE OPTIONS screen when programming your meter.

If you are not sure that your meter ID is entered in your pump, check the REVIEW METER ID screen.

You have to turn on the meter option to add, delete, or review the meter ID(s) programmed in your pump.

- 1 Go to the METER OPTION screen.
Main > Utilities > Meter Options
- 2 Select **On**, then press **ACT**. The METER ID MENU appears.
- 3 Add, delete or review your meter ID(s) as desired.

Adding meter IDs

- a. Select **Add ID**, then press **ACT**.
- b. Use the up and down arrow buttons to enter each of the six ID characters. Press **ACT** after each entry.
- c. After you set the last character of the ID, the screen will return to the METER ID MENU.

Deleting meter IDs

- a. Select **Delete ID**, then press **ACT**.
- b. Select the meter ID that you want to delete and press **ACT**.
- c. The selected ID is now deleted.

Reviewing meter IDs

- a. Select **Review ID**, then press **ACT**.
- b. The programmed IDs will show in the REVIEW METER ID screen.

- 4 Exit the menus when you are done.

Normal bolus using Bolus Wizard feature

After the Bolus Wizard feature is turned on and programmed, this feature can calculate an estimate of insulin you need for your correction bolus and/or your food bolus. You have the option of using the estimate or changing it as necessary. Additionally, your pump can receive your blood glucose reading from the meter, if they are linked.

Use the  button to deliver a Normal bolus at any time except during another Normal bolus. A Normal bolus will temporarily interrupt a Square Wave or Dual Wave bolus that is delivering. After the Normal bolus is finished, the Square Wave or Dual Wave bolus delivery will resume.

NOTE: *If you want to use the pump-to-meter link, make sure the meter option is on. Refer to the Meter option section in this chapter for instructions.*

- 1 If you want a correction bolus, check your blood glucose with your blood glucose meter and go to step 2. If you want to bolus for food, go to step 2.
- 2 Press  on your pump, or go to the BOLUS MENU, select **Use Bolus Wizard**, and press **ACT**.
- 3 The ENTER BG screen will appear.
 - a. If you are NOT using the meter:
Enter your blood glucose value. Press **ACT** and continue to step 4.
If you are not entering a blood glucose and want to bolus for food, select the dashes in the ENTER BG screen. The Bolus Wizard feature will calculate the insulin needed for your food entry without considering your blood glucose level. Press **ACT** and continue to step 4.
 - b. If you are using the meter, your pump checks if the entered BG is within your target range.

NOTE: *You must program your bolus within 12 minutes of the pump receiving the reading from the meter. If more than 12 minutes have passed, the reading will no longer be available from the screen and you must enter your blood glucose manually.*

Press **ACT** to accept the Blood glucose value. You can change this blood glucose value, if necessary, then press **ACT**. Continue to step 4.

- 4 The ENTER FOOD screen appears.
 - a. If this is a food bolus, enter the food value you will eat, then press **ACT**.
 - b. If this is a correction bolus, select 0 (zero) as the value, then press **ACT**.
- 5 The ESTIMATE DETAILS screen appears. Review the information in this screen. If you need to make any changes, press **ESC** to return to the ENTER BG screen (step 3) and make changes as necessary.
- 6 Press **ACT** In the ESTIMATE DETAILS screen. The SET BOLUS screen appears with the estimated bolus amount flashing. Change the amount if desired. Press **ACT** to accept and start delivery of the bolus.

NOTE: *If you have BG Reminder turned On, a screen displays allowing you to accept or modify the length of time after this bolus before you are reminded to check your BG. See the BG reminder section in the Basic programming chapter for information about this feature.*

- 7 The BOLUS DELIVERY screen appears. The pump will beep or vibrate at the start and end of the bolus. As the bolus is delivered, the screen shows the bolus type and amount until the total units have been delivered. The screen then returns to the HOME screen.

Bolus Wizard feature examples

For the scenarios that follow, Michael has his Bolus Wizard feature turned on with the following settings:

Carb ratio: 15 grams per unit of insulin

Insulin Sensitivity: 40 mg/dL (2.2 mmol/L) per unit of insulin

BG Target: 90 - 120 mg/dL (5.0 - 6.6 mmol/L)

Active Insulin Time: 6 hours

NOTE: If you want to see details of the formulas the Bolus Wizard feature uses to calculate estimate boluses like the ones in the following examples, see the Bolus Wizard feature specifications section in the Pump specifications chapter.

Example 1: Blood glucose on target (normal blood glucose) and no active insulin

Michael awakens in the morning before school and his mother has breakfast waiting for him. Before he begins eating, he tests his blood glucose with his meter and his blood glucose result of 120 mg/dL (6.6 mmol/L) is automatically sent to his pump.

He estimates that his meal consists of 60 grams of carbohydrates. When prompted by the Bolus Wizard feature, he enters this amount in the ENTER FOOD screen. Based on his Bolus Wizard feature settings, the pump will suggest that he take 4.0 units of insulin.

(food estimate)

$$\frac{60 \text{ g}}{15 \text{ g/u}} = 4 \text{ units}$$

+

(correction estimate)

Correction is 0 because the current blood glucose reading is within the BG Target Range.

$$= 4 + 0$$

bolus estimate = 4 units

Example 2: Blood glucose above target (high blood glucose) and no active insulin

The next day, Michael wakes up before school. Before eating the same breakfast, he tests his blood glucose with his meter and finds it to be 200 mg/dL (11.1 mmol/L), which is above his target of 120 mg/dL (6.6 mmol/L). His blood glucose reading is automatically sent to his pump.

When prompted by the Bolus Wizard feature, he enters his carbohydrate amount of 60 grams in the ENTER FOOD screen. Based on his settings, the pump will suggest that he take 6.0 units of insulin.

$$\begin{array}{rcl} \text{(food estimate)} & & \text{(correction estimate)} \\ \frac{60 \text{ g}}{15 \text{ g/u}} = 4 \text{ units} & + & \frac{11.1 \text{ mmol/L} - 6.6 \text{ mmol/L}}{2.2 \text{ mmol/L/u}} = 2 \text{ units} \\ & & \frac{200 \text{ mg/dL} - 120 \text{ mg/dL}}{40 \text{ mg/dL/u}} = 2 \text{ units} \\ & & = 4 + 2 \\ \text{bolus estimate} & = & 6 \text{ units} \end{array}$$

Example 3: Blood glucose below target (low blood glucose) and no active insulin

On another morning, Michael sits down before eating the same breakfast. He tests his blood glucose with his meter and finds it at 70 mg/dL (3.9 mmol/L), which is below his Low BG target of 90 mg/dL (5.0 mmol/L). His reading is automatically sent to his pump.

When prompted by the Bolus Wizard feature, he enters his carbohydrate amount of 60 grams in the ENTER FOOD screen. Based on his settings, the pump will suggest that he only take 3.5 unit of insulin.

$$\begin{array}{rcl} \text{(food estimate)} & & \text{(correction estimate)} \\ \frac{60 \text{ g}}{15 \text{ g/u}} = 4 \text{ units} & + & \frac{3.9 \text{ mmol/L} - 5.0 \text{ mmol/L}}{2.2 \text{ mmol/L/u}} = -0.5 \text{ units} \\ & & \frac{70 \text{ mg/dL} - 90 \text{ mg/dL}}{40 \text{ mg/dL/u}} = -0.5 \text{ units} \\ & & = 4 + (-0.5) \\ \text{bolus estimate} & = & 3.5 \text{ units} \end{array}$$

Example 4: Blood glucose above target (high blood glucose) with active insulin

Michael is at school and wants to eat a snack in the late morning. He tests his blood glucose with his meter and finds it to be at 200 mg/dL (11.1 mmol/L), which is above his target of 120 mg/dL (6.6 mmol/L). He estimates that his snack contains 60 grams of carbohydrate, so he enters 60 into the pump when prompted by the Bolus Wizard feature. Based on his settings, and as a result of 1.5 units of active insulin, his pump will suggest that he take 4.5 units.

(food estimate)

(correction estimate)

$$\frac{60 \text{ g}}{15 \text{ g/u}} = 4 \text{ units} \quad + \quad \frac{11.1 \text{ mmol/L} - 6.6 \text{ mmol/L}}{2.2 \text{ mmol/L/u}} - 1.5 \text{ units (active insulin)} \quad = 0.5 \text{ units}$$

$$\frac{200 \text{ mg/dL} - 120 \text{ mg/dL}}{40 \text{ mg/dL/u}} - 1.5 \text{ units (active insulin)} \quad = 0.5 \text{ units}$$

$$= 4 + 0.5$$

$$\text{bolus estimate} = 4.5 \text{ units}$$

Example 5: Blood glucose below target (low blood glucose) with active insulin

Another day at school, Michael is getting ready to eat lunch. He tests his blood glucose with his meter and finds it at 70 mg/dL (3.9 mmol/L), which is below his Low BG target of 90 mg/dL (5.0 mmol/L). His reading is automatically sent to his pump.

When prompted by the Bolus Wizard feature, he enters his carbohydrate amount of 60 grams in the ENTER FOOD screen. Based on his settings, and despite 1.5 units of active insulin, his pump will suggest that he take 3.5 units of insulin.

(food estimate)

(correction estimate)

$$\frac{60 \text{ g}}{15 \text{ g/u}} = 4 \text{ units}$$

+

$$\frac{3.9 \text{ mmol/L} - 5.0 \text{ mmol/L}}{2.2 \text{ mmol/L/u}} - 0^* \text{ units (active insulin)}$$

$$= -0.5 \text{ units}$$

$$\frac{70 \text{ mg/dL} - 90 \text{ mg/dL}}{40 \text{ mg/dL/u}} - 0^* \text{ units (active insulin)}$$

$$= -0.5 \text{ units}$$

$$= 4 + (-0.5)$$

$$\text{bolus estimate} = 3.5 \text{ units}$$

NOTE: **When the current blood glucose is below the target low blood glucose, the active insulin amount is not considered in the Bolus Wizard feature calculations.*

Optimizing pump therapy

Square Wave and Dual Wave bolus

Square Wave bolus delivers a bolus evenly over a period of time (30 minutes to 8 hours). This bolus can be used for insulin delivery when you have eaten a long meal with extended snacking. It can also be useful if you have delayed food digestion due to gastroparesis or meals high in fat. A Square Wave bolus can be useful if a Normal bolus drops your blood glucose too rapidly. Since the Square Wave portion extends over a period of time, the insulin is more likely to be available to match your individual needs.

NOTE: *During delivery of a Square Wave bolus, you will not be able to do the following pump functions: change the max bolus amount, disable or deliver Dual and Square Wave boluses, rewind or do a fixed prime, change the active insulin time, run a Selftest, or access the User Settings menu. All other pump functions are still available during the Square Wave bolus.*

Dual Wave bolus delivers a combination of an immediate Normal bolus followed by a Square Wave bolus. The Square Wave portion is delivered evenly over a period of time. A Dual Wave bolus is useful for meals with both rapidly and slowly absorbed carbohydrates. For example, a Dual Wave bolus would be appropriate for fruit and crackers followed by pasta. The Dual Wave option meets both immediate and extended insulin needs. A Dual Wave bolus is also useful for correcting elevated blood glucose before a meal.

See the following graphic for a description of the different bolus types:

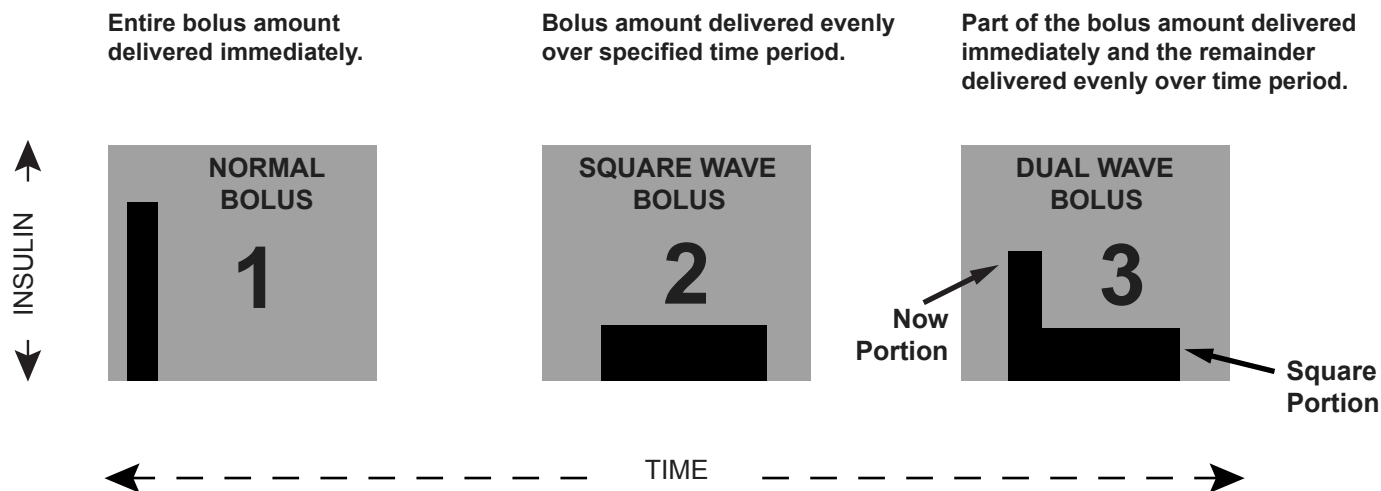

Turning on the Dual Wave/Square Wave option

It is important that you consult with your healthcare professional before using a Square Wave or Dual Wave bolus. You should be familiar with the basic functions of your pump before exploring these options.

To set up a Dual Wave or Square Wave bolus, you must first turn on the dual/square bolus option.

- 1 Go to the DUAL/SQUARE OPTION screen.
Main > Bolus > Dual/Square Bolus
- 2 Select **On**, then press **ACT**. The feature is now on. Exit the menus.

Square Wave or Dual Wave bolus without Bolus Wizard feature

- 1 Make sure the dual/square option is on.
- 2 Calculate your food and/or correction bolus amount.
- 3 Go to the BOLUS TYPE screen.



Press  on your pump, or follow this path:

Main > Bolus > Set Bolus

4 For a Square Wave bolus, do these steps:

- a. Select **Square Wave Bolus**, then press **ACT**. The SET SQUARE BOLUS screen appears.
- b. Enter the desired amount for the Square Wave bolus units, then press **ACT**.
- c. Continue to step 5.

For a Dual Wave bolus, do these steps:

- a. Select **Dual Wave Bolus**, then press **ACT**. The SET DUAL BOLUS TOTAL screen appears.
 - b. Enter the desired amount for the total dual bolus units. This amount is the total of Normal and Square Wave bolus units. Press **ACT**.
 - c. The next screen flashes the amounts of Now (Normal) and Square Wave portions of the Dual Wave bolus. The screen also shows the percentage amount of each portion. Press  or  to change the percentage/number of units. Continue to step 5.
- 5** The SQUARE DURATION screen appears. Enter the amount of time you want the Square Wave bolus to last, then press **ACT**.
If you have BG Reminder turned On, a screen displays. It allows you to accept or modify the length of time after this bolus before you are reminded to check your blood glucose.
- 6** The BOLUS DELIVERY screen appears with an open circle indicating that your pump is in Special mode. The pump beeps/vibrates at the start of the bolus. During bolus delivery, the pump will return to the HOME screen. The pump beeps/vibrates at the end of the bolus and the open circle disappears.

Square Wave bolus practice

Your target pre-meal blood glucose range is _____ to _____.

Check your pre-meal blood glucose. Are you within your target? _____ If yes, continue. If no, wait to try the following test until your pre-meal blood glucose is within your target range:

TEST: Choose a meal that is high in fat (e.g. hot dogs, pizza, cheese enchiladas). Determine your meal bolus amount. Set the Square Wave bolus to deliver the determined amount of insulin over 2-hours. (This duration time is an example. As always, consult with your healthcare professional for guidance.)

Check your blood glucose and record:

Pre-meal _____

1 hour post meal _____

2 hours post meal _____

3 hours post meal _____

4 hours post meal _____

Did your blood glucose return to your pre-meal target within 4 hours post meal? _____

If yes, then repeat this test with the same meal on another day to verify your results.

If no, discuss this with your healthcare professional for guidance.

Dual Wave bolus practice

Can you think of any meals where this feature would help you with blood glucose control?

Your target pre-meal blood glucose range is _____ to _____

Check your pre-meal blood glucose. Are you within your target? _____ If yes, continue. If no, try this test when your pre-meal blood glucose is within your target range:

TEST: Choose a meal that has a combination of both rapidly absorbed and slowly absorbed carbohydrates. Determine your meal bolus amount. Set the Dual Wave bolus to deliver the determined amount of insulin. Program your pump to deliver one-half over 2-hours*, and the other half immediately. (* This duration of time and ratio is an example. As always, consult with your healthcare professional for guidance.)

Check blood glucose and record:

Pre-meal_____

1 hour post meal_____

2 hours post meal_____

3 hours post meal_____

4 hours post meal_____

Did your blood glucose return to your pre-meal target within 4 hours post meal? _____*

If yes, repeat this test with the same meal on another day to verify results.

If no, discuss this with your healthcare professional for guidance.

Using the Bolus Wizard feature for a Square Wave or Dual Wave bolus

If you are using the Bolus Wizard feature to calculate your Square Wave or Dual Wave bolus amounts, you will be prompted to enter your blood glucose reading and/or the (gram or exchange) units you will eat. The Bolus Wizard feature will use this input to calculate your suggested correction and/or food bolus amount. If you do not want to use the Bolus Wizard feature estimate, you can change it.

The Bolus Wizard feature must be turned on and the settings must be programmed (see the *How to program the Bolus Wizard feature* section of the *Using the Bolus Wizard* chapter). Also, make sure the dual/square option is turned on (see the *Turning on the Dual Wave/Square Wave option* of this chapter).

If you want to use the pump-to-meter link, make sure the meter option is on. Refer to the *Meter option* section of the *Using the Bolus Wizard feature* chapter for instructions.

1 Go to the ENTER BG screen.

Press  on your pump, or use the following path:

Main > Bolus > Use Bolus Wizard

2 Enter your blood glucose value, then press **ACT**.

3 The ENTER FOOD screen appears. Enter your food, then press **ACT**.

4 The ESTIMATE DETAILS screen appears. Scroll down to review the information there. Press **ACT** to continue to step 5.

If you need to make any changes, press **ESC** to return to the ENTER BG screen. Make changes as necessary.

5 The BOLUS EST screen appears with Normal Bolus, Square Wave Bolus, and Dual Wave Bolus options. If your Bolus Wizard feature calculates that your bolus includes a portion to correct your high blood glucose, the Square Wave Bolus option will not be available. This helps you to select a bolus type (Normal or Dual Wave) that has an immediate delivery option to cover your high blood glucose.



6 **To set a Square Wave bolus, do these steps:**

a. In the BOLUS EST screen, select **Square Wave Bolus**, then press **ACT**.

b. The SET SQUARE BOLUS screen flashes the estimated bolus amount. Change the amount if needed. Press **ACT** to accept the bolus amount.

To set a Dual Wave bolus, do these steps:

a. The SET DUAL BOLUS TOTAL screen flashes the estimated bolus amount. This amount is the total of both the Normal and Square Wave bolus units. Change the amount if needed. Press **ACT** to accept the bolus amount.

b. The next screen flashes the amounts of Now (Normal) and Square portions of the Dual Wave bolus. The screen also shows the percentage amount of each portion. Press **ACT** to accept the Bolus Wizard's suggested portions. You can also press  or  to change these portions, then press **ACT**.

The Bolus Wizard feature recommends splitting the food portion of your bolus 50/50 between the Square and Now portions. The entire correction amount is always recommended to the Now portion. In this example the NOW portion consists of half of the food insulin plus the correction amount less the active insulin (1.5U + 2.5U - 1.5U). This gives 2.5U or 62% of total insulin of 4.0U. The Square portion consists of the other half of the food insulin (1.5U), which is 38% of total insulin of 4.0U.

7 The SQUARE DURATION screen appears. Enter the amount of time you want the Square Wave bolus to last, then press **ACT**.

If you have BG Reminder turned On, a screen displays. It allows you to accept or modify the length of time after this bolus before you are reminded to check your blood glucose.

- 8 Press **ACT** to accept and deliver the bolus. The BOLUS DELIVERY screen appears with an open circle indicating that your pump is in Special Mode. The pump beeps/vibrates at the start of the bolus. During bolus delivery, the pump returns to the HOME screen. If you want to see the progress of the delivery, press **ESC** to see the STATUS screen. The pump beeps/vibrates at the end of the bolus, and the open circle disappears.

Easy bolus

The **EASY BOLUS** button  allows a quick way to deliver a Normal bolus. You will pre-set the settings for this feature in the EASY BOLUS OPTION screen in the BOLUS MENU. Your pump is sent from the factory with the Easy Bolus feature set to on. If you do not want to use Easy Bolus, turn it off.

After you set up Easy Bolus, with each  press, you can increase the Normal bolus amount by a fixed amount, called a step. Before you can deliver an Easy Bolus, you must set the amount in the EASY BOLUS ENTRY screen. This amount equals the number of units of insulin for each step. The maximum number of steps can equal up to your maximum bolus limit. When using vibrate mode, EASY BOLUS is limited to 20 steps or maximum bolus, whichever comes first.

After you set your step amount, you can program your Easy Bolus. When you are in the HOME screen, each time you press  the Easy Bolus amount increases by one step. You will hear a beep or feel a vibration for each step increase. Each beep is a different tone. This makes it easy for you to count the beeps while you are programming your Easy Bolus.

Easy bolus setup

- 1 Go to the EASY BOLUS OPTION screen.

Main > Bolus > Easy Bolus

Select **On/Set**, then press **ACT**. If you do not want to use Easy Bolus, select **Off** and press **ACT**.

NOTE: *If you are using the remote control, the Easy Bolus must be set to on.*

Step value setup

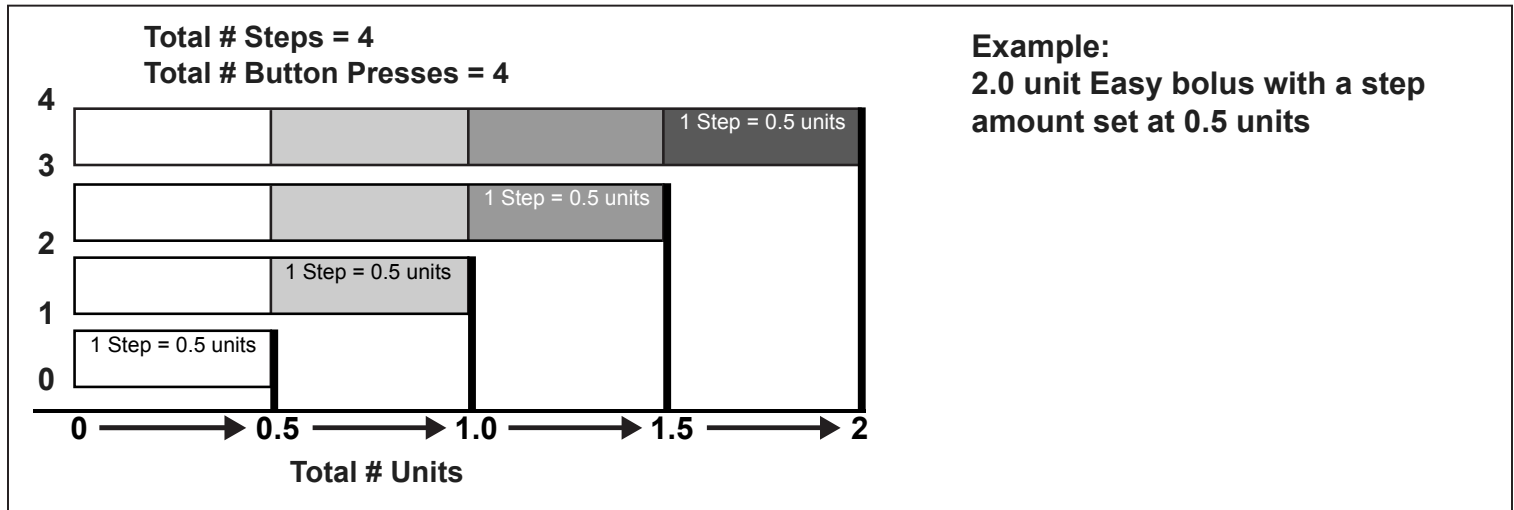

You can set the step value from 0.1 to 2.0 units, or to the set maximum bolus limit of less than 2.0 units (factory setting: 0.1). Set the step to a number that is convenient to use and easy to multiply.





- 1 The EASY BOLUS ENTRY screen flashes the step value. Change the value, then press **ACT**. The step value is the increment you will use for your Easy bolus.
- 2 The screen will return to the BOLUS MENU. Your step amount is now programmed and Easy Bolus is ready to use. Exit the menus.

Delivering Easy Bolus

Practice using the Easy Bolus feature while looking at the pump screen as you count the beeps. This feature only works from the HOME screen. After you are familiar with Easy Bolus, you can use the audible tones for bolus delivery without having to look at the screen.

- 1 From the HOME screen, press . The SET EASY BOLUS screen appears with the single step value flashing.
- 2 Press  the number of times needed for your bolus amount. Watch the amount change on the screen with each press. The pump will vibrate or sound a different tone for each  press.
- 3 When your total bolus amount appears on the SET EASY BOLUS screen, press **ACT**. Listen/feel to count the steps without looking at the screen.

For example: You need to deliver a 2.0 unit bolus, and your step size is set to 0.5. Each time you press , the units increase by the step amount of 0.5 units. To deliver 2.0 units, you need to press the  button 4 times. ($4 \times 0.5 = 2.0$) The screen will show 2.0 units.



NOTE: For your safety, you cannot use the  to select the Easy Bolus values. Pressing  or ESC will cancel the Easy bolus.

- 4 If this amount is correct, press **ACT** to start the Easy Bolus delivery. The BOLUS DELIVERY screen will show the units being delivered. When the total bolus is finished, the pump will beep or vibrate. If this amount is wrong, press **ESC** or  to start over. The pump will return to the HOME screen.

Example 1: Easy bolus

Alexander is a busy executive with an accounting firm. He wears his Paradigm pump on his belt and does not want to take it off to give himself a bolus. Alex can easily reach down and feel for the Easy Bolus button  to give a bolus.

He previously programmed his pump to deliver an Easy Bolus in steps of 0.5 unit increments. From the HOME screen, with each press of the , the pump will sound a different tone so he can keep track of the number of button presses.

He wants to give himself 2.0 units for a snack, so he will press  4 times ($4 \text{ presses} \times 0.5 \text{ units/press} = 2.0 \text{ units}$) and then press the **ACT** button. The pump counts back 4 beeps because he pressed  4 times. He simply presses **ACT** to confirm the amount, and his pump delivers the 2.0 units.

When Alexander wants to be more discrete, or does not want his pump to beep in an important meeting, he can set the pump to Vibrate mode and feel for vibrations rather than listening for the tones. (See the *Setting your alert* section of the *Utilities* chapter for details.)

Your turn: Easy bolus practice

The factory default setting for the Easy Bolus feature is 0.1 unit steps. You can change the step level as necessary to a value that is more convenient for you to use and easier to multiply.

Give your next bolus by using the Easy Bolus feature on your pump.

How many units did you give? _____ Your step level is _____.

How many tones did you count? _____

It might be a good idea to look at your pump's screen to see the bolus amount as well as counting the steps the first few times you try this until you become familiar and comfortable with the feature.

Basal patterns

The Basal Patterns feature is optional for pump users. You can set your pump to deliver a standard basal and two additional basal patterns to meet your individual daily, weekly, or monthly needs. Keep a paper copy of your programmed patterns with you at all times in case you need to reprogram your pump. To select and use pattern A or pattern B, the patterns option must be turned on and programmed.

NOTE: *You may want to explore this option after you become familiar with the basic pump functions. It is important that you consult your healthcare professional before using a pattern other than your standard pattern.*

- Standard pattern: Your normal basal that supports your usual day-to-day activity. When the Patterns feature is off, the pump uses your standard basal pattern.
- Pattern A/B: Basal pattern that supports activity levels that are not a part of your day-to-day routine, but are normal in your lifestyle. Such activities could be a sport that you do once a week or a change in your sleep pattern over the weekend, extended periods of higher or lower activity, or menses.

Turning on the patterns

Your pump is set at the factory with the basal patterns feature turned off. After you turn on patterns, you still have to program and select a pattern (A or B), as described in the next sections, before the patterns feature is active. If you turn off the patterns feature, your pump will automatically select your standard basal pattern.

- 1 Go to the PATTERNS OPTION screen.
Main > Basal > Patterns
- 2 Select **On**, then press **ACT**. The patterns feature is now on. Exit the menus.

Programming a pattern

Your pump will keep your pattern settings even when the Patterns option is turned off. However, the patterns feature must be on to program a basal pattern.

To program your patterns, do these steps:

- 1 Go to the EDIT BASAL screen.
Main > Basal > Set/Edit Basal
- 2 Select the basal pattern you want to program, then press **ACT**.
- 3 The SET BASAL RATE 1 screen appears. The basal rate flashes, indicating that it can be changed. Set your first rate, then press **ACT**.
The start time for your first basal rate is midnight and cannot be changed.
- 4 The SET START TIME 2 screen appears. The dashes under the screen name flash. The first basal rate is now set.
If you want to use the same rate for the whole day, press **ESC** and skip to step 10. If you want to program another basal rate, follow steps 5 through 8.
- 5 In the SET START TIME 2 screen enter the time of the day you want this basal rate to become active.
- 6 Press **ACT**. The SET BASAL RATE 2 screen appears.
- 7 The previously set basal rate or dashes flash on the screen. Select the value for this basal rate.
- 8 Press **ACT**. The SET START TIME 3 screen appears. The second basal rate is now set.
- 9 If you do not need to set up any more basal rates, press **ESC**. If you need to set up more basal rates, repeat steps 5 through 8 above for each rate.
- 10 After you press **ESC**, the BASAL RATE screen appears. The screen will show:
 - the current basal pattern and basal rate,
 - time it started, and
 - the 24-hour basal total.After you make changes to a pattern, the pump will use that pattern as the current basal. Make sure the basal you want is selected in the SELECT PATTERNS screen.

Select a pattern

Before you select a pattern to be active, make sure the Patterns feature is turned on. After your standard pattern and/or pattern A or B are set, do these steps to select a pattern to be the active one:

- 1 Go to the SELECT PATTERN screen.
Main > Basal > Select Patterns
- 2 Select the desired pattern, then press ACT.
- 3 The screen will return to the BASAL MENU. Your basal pattern is now active. Exit the menus.

NOTE: *If pattern A or B is active, the pump is in Special mode. An open circle appears at the top of the screen.*

Example 1: Basal patterns

Ken has had his insulin pump for about a month. He tests his blood glucose 4 - 6 times a day and records his results in his logbook. He is happy with his glucose control during the week but on the weekends, he noticed that he has to eat more food to prevent his blood glucose from running too low.

Ken has realized that during the week while he is at work, he is very inactive and sits at a desk most of the time. On the weekends, though, he is busy with yard work, running errands and playing with his kids. He determines that he needs to have lower basal settings to receive less insulin during active times, such as his weekend.

He can use the Basal Patterns feature to support his weekend change in activity. During the week, he can set his pump to deliver in the standard setting, and on Saturday morning, he can switch over to Pattern A, which he can set with lower basal rates for the weekend. On Monday morning, he can return his pump to the Standard setting for his weekday insulin needs.

Example 2: Basal patterns

Cynthia has had diabetes for about 12 years and has been on her Paradigm pump for several weeks. Every Monday, Wednesday and Friday, Cynthia goes on a 3 kilometer walk in the morning. To prevent hypoglycemia on these days, she uses the patterns feature. For those days, she simply switches over to Pattern A, which she has programmed with a lower set of basal rates. Before she learned to use the patterns feature, she would have to eat more food throughout the day to keep her blood glucose at a safe level. Cynthia has also noticed that a few days prior to menstruation, her blood glucose levels seem to rise, requiring more insulin. She has programmed Pattern B on her Paradigm pump with higher basal rates for this time. For her usual schedule, she uses the standard basal pattern.

Your turn:

Can you think of situations where you might require different basal rate settings on different days?

Temp basal rates

Temp basal should be used based on the guidance of your healthcare professional. This feature is useful to manage blood glucose levels during **unusual** short-term activities or conditions. These conditions could be an illness or physical activity.

A temporary basal rate allows an immediate short-term change to your basal insulin for a specified period of time (30 minutes to 24 hours). This rate can be up to your maximum basal rate setting. It offers an easy way to immediately meet short-term insulin needs for temporary activities or situations. When your blood glucose is temporarily high or low, a temp basal rate allows you to set a temporarily higher or lower basal to accommodate your blood glucose. For ongoing periods of increased or decreased activity, the patterns feature may be more suitable.

How does temp basal work?

During a temp basal delivery, all other basal programming is temporarily overridden. After the temp basal delivery is completed, your pump will return to the programmed basal. A temp basal is delivered only once and does not repeat. If you want another temp basal, you must program the temp basal again. This feature may be useful to temporarily increase or decrease basal insulin during illness, exercise or similar unusual situations.

Temp basal types

Based on your preference, you can select either Percent of Basal or Insulin Rate.

Insulin rate (U/H)

Insulin rate is a fixed basal in units per hour (U/H). This temp basal type is independent of your current basal. When you select **Insulin rate (U/H)** for your temp basal type, your pump will deliver the fixed amount you have set for the duration as set. The amount of your temp basal insulin rate can be set up to your maximum basal rate setting.

If you make changes to your normal basal rate, your U/H temp basal is not affected and will continue to deliver as programmed.

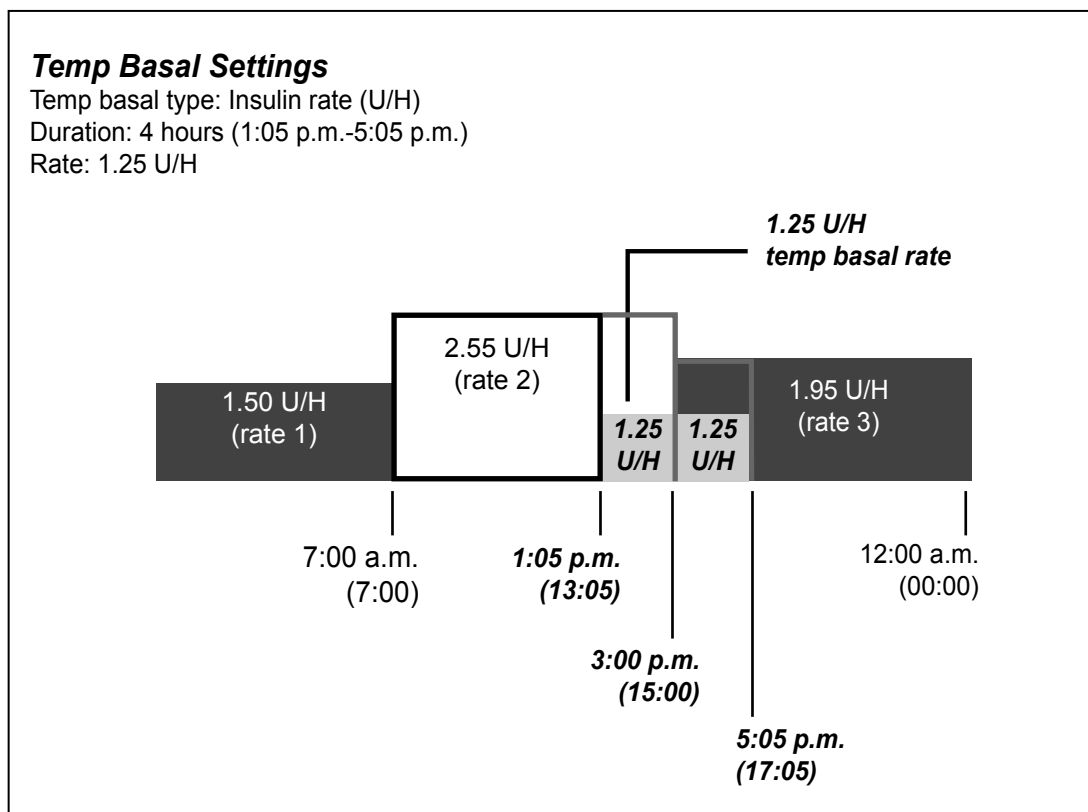

Percent of basal

Unlike insulin rate, the percent of basal is dependent on your current basal rates. Percent temp basal is a percentage of your current basal (0 - 200 percent limited to your maximum basal rate setting).

The maximum percent limit is based on the largest basal rate segment with your programmed temp basal rate time.

For example: It is 6:00 AM and your current basal rate is 1.50 U/H. You want to set a temp basal rate of 130 percent for seven hours. The maximum percent temp basal rate you can set is 125 percent. Anything larger would make #2 segment exceed your maximum basal setting of 2.0 U/H.

Your current basal rates:	Your maximum basal rate setting: 2.0 U/H
Segment #1: 00:00	1.50 U/H
Segment #2: 11:00	1.60 U/H (largest)
Segment #3: 16:00	1.30 U/H

If your current basal changes (i.e. from rate 1 to rate 2), your percent temp basal amount will also change. The pump will deliver the percentage for the duration that you have set.

You cannot make changes to your normal basal rate while a percent temp basal is active. You must either wait until the temp basal is finished or cancel the temp basal in order to reprogram your normal basal rate setting(s).

NOTE: *The pump delivers basal amounts in 0.05 U/H increments. Because of this, your temp basal amount will be rounded down to the next 0.05 U/H increment.*

Temp Basal Settings

Temp basal type: Percent of basal

Duration: 4 hours (1:05 p.m. - 5:05 p.m.)

Rate: 50%

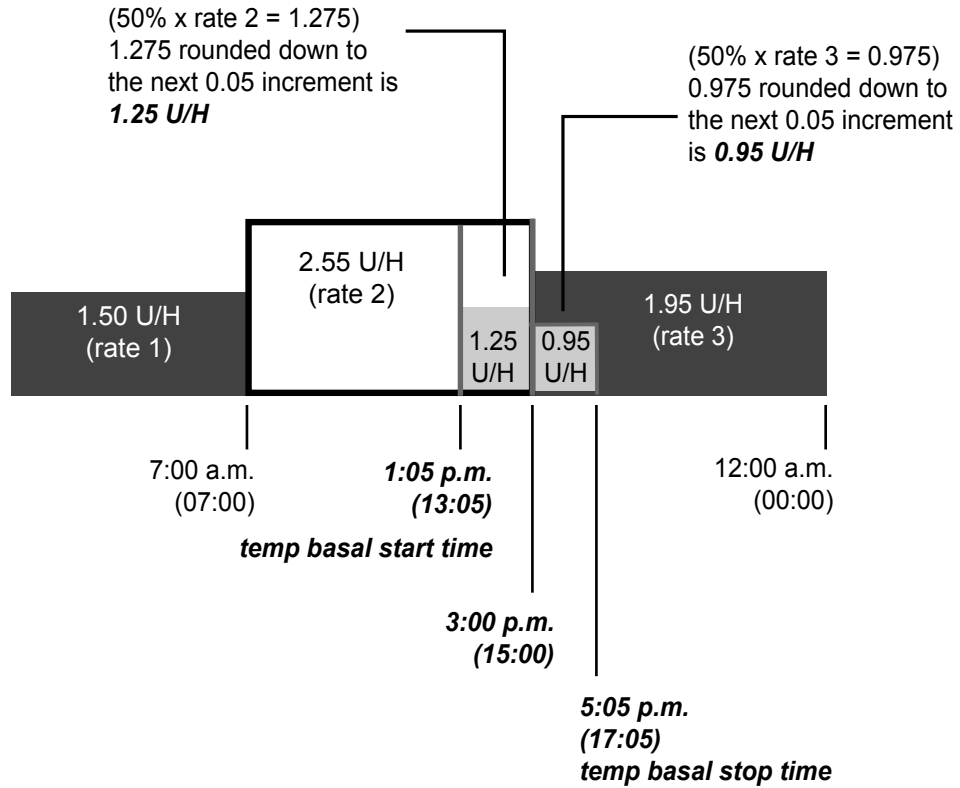

Selecting temp basal type

Your pump will remember the temp basal type setting. Once the type is set, you do not have to set it again. To select a temp basal type, do these steps:

- 1 Go to the SET TEMP BASAL AS screen.
Main > Basal > Temp Basal Type
- 2 The SET TEMP BASAL AS screen appears. Select **Insulin Rate (U/H)** or **Percent of Basal**, then press **ACT**.
- 3 The screen will return to the BASAL SETUP screen. The temp basal type is now set. Exit the menus. If you select **Percent of Basal** as your temp basal type, changes to your basal rate are not allowed until after temp basal is completed or cancelled.

Delivering a temp basal

A temp basal cannot exceed your programmed max basal rate.

- 1 Go to the BASAL MENU.
Main > Basal
- 2 Select **Set/Edit Temp Basal**, then press **ACT**.
- 3 The SET DURATION screen appears. The duration will flash. Duration is the amount of time it will take for the pump to deliver the temporary basal. Enter the desired minutes or hours (30 minutes to 24-hours), then press **ACT**.
- 4 If you have selected insulin rate as your temp basal type, the SET TEMP BASAL U/H screen appears. If you have selected percent of basal as your temp basal type, the SET TEMP BASAL % screen appears. The temporary basal rate will flash. Enter your temp basal rate, then press **ACT**.
- 5 The BASAL MENU screen appears with an open circle at the top of the screen. Your pump is in Special mode; temp basal is now set and delivering. Exit the menus.

Verifying temp basal delivery

Temporary basal information is available in the STATUS screen only.

During a temporary (temp) basal, the pump is in Special mode (an open circle appears). This open circle will remind you that a temp basal is active.

Additionally, your pump will beep/vibrate three times every hour during delivery. During delivery, go to the STATUS screen to see the current temp basal information.

Temp Basal of 0.6 units per hour is now active

Temp Basal delivery will last 30 minutes

4 minutes remaining before Temp Basal delivery is finished

regular programmed basal rate will resume after the Temp Basal delivery is finished

Press down button to scroll

Canceling a temp basal

Use the Cancel Temp Basal function in the BASAL MENU to cancel a temporary basal. This function immediately stops the temp basal and resumes the regular programmed basal delivery.

To cancel a temp basal, do these steps:

- 1 Go to the BASAL MENU.

Main > Basal

- 2 Select **Cancel Temp Basal**, then press **ACT**.

The screen will return to the BASAL MENU. Your temp basal is cancelled and open circle has disappeared from the top of the screen. The programmed basal is now active again. Exit the menus.

Example 1:
Temp Basal for a decreased temporary basal rate

Ramon and his friends got together for an unplanned game of soccer. Before using the pump, he was taking shots to manage his diabetes. Ramon experienced frequent low blood glucose reactions sometimes during, and very often after, he played games with his friends. Now that he is using his Paradigm pump, he can use the Temporary Basal Rate feature to help prevent low blood glucose. He simply programs his pump to temporarily deliver less basal insulin during the time that he is playing, and often for several hours after play, as well.

Ramon was able to determine how to set his Temporary Basal rates by frequent blood glucose testing, both during and after activity, and recording his results. The first time he tried using the pump, his healthcare professional advised him to program his pump to deliver 1/2 his usual basal rate for the amount of time that he was playing and for an hour after he was done. He made small adjustments of the temporary basal rate and the duration of time, each time he tried to use the feature. After several different attempts with similar activity for the same amount of time, (such as his soccer game that lasted 2 hours), he found a temporary basal rate that worked well for him.

Example 2:
Temp Basal for an increased temporary basal rate

Gail has had a cold with a cough for a couple of days. Because she is not feeling well, she tests her blood glucose more frequently. She finds that her blood glucose levels are running above target range before meals and she has needed several correction boluses to keep her blood glucose levels within her normal limits. Gail decides to use the Temporary Basal Rate to increase her basal rate during the day today. As advised by her healthcare professional, she will continue to check her blood glucose more frequently until she is feeling well.

Your turn:

Think of an activity where you might need to use a Temporary Basal Rate.

At what rate is your current basal rate running? _____

What Temporary Basal Rate would you try using at this time? _____

How long will you be active? _____

What duration will you set for the Temporary Basal Rate? _____

Test your blood glucose before and during activity and several times after as well. What are your blood glucose results?

Pre- activity _____

During activity _____

1 hour after activity _____

Several hours after activity _____

What Temporary Basal Rate changes will you make for the next time you try this?

Utilities

Alarm review

You can review alarms in the ALARM HISTORY screen. This screen shows up to 36 past alarms and/or errors. You can also review the details for each alarm when you are in the ALARM HISTORY screen.

- 1 Go to the ALARM HISTORY screen.
Main > Utilities > Alarm > Alarm History
- 2 Scroll through your past alarms.
- 3 In the ALARM HISTORY screen, select the alarm you want to review and press **ACT**. The details for that alarm will appear on the screen.
- 4 Press **ESC** to return to the ALARM HISTORY screen. Select another alarm to review, or exit the menus if you are done.

Setting your alert type

You can select the type of alert your pump uses (for alarms, special conditions and programming). You can select a vibrate (silent) alert, or an audible beep alert. There are three beep types: long, medium and short tones. The factory setting for this feature is beep-medium.

The vibrate alert type is disabled if you use the block feature, and vibrate must be set again once block is turned off. Vibrate uses more battery power than the beep alert type and may shorten battery life. If your alert type is set to vibrate and you get a LOW BATTERY alert, your pump will use the beep alert type instead to conserve battery power.

- 1 Go to the ALERT TYPE screen.
Main > Utilities > Alarm > Alert Type
- 2 Select your alert type and press **ACT**. That alert type is now active. Exit the menus.

Auto-off

The factory setting for this feature is **Off**. This is a safety feature that stops insulin delivery after a defined time period (from 1 to 24 hours). If the pump detects that no buttons have been pressed for the selected amount of time in Auto-off, insulin delivery will stop and an alarm will sound. You may choose to program this feature into your pump based on the numbers of hours that you usually sleep at night. Discuss what uses and settings are best for you with your healthcare professional.

- 1 Go to the AUTO OFF DURATION screen.
Main > Utilities > Alarm > Auto Off
- 2 Set the number of hours you want to set and press **ACT**.
If you do not want to use the Auto Off feature, make sure the hour is set to zero (0).
- 3 The screen will return to the ALARM MENU. The Auto Off feature is now set. Exit the menus.

LOW RESV WARNING (Low reservoir warning)

Allows you to program the pump to sound an alert before your reservoir is empty. You can select one of these warning types:

- a specified number of units that remain in the reservoir
- a specified maximum amount of time that remains before the reservoir will be empty

The factory setting for this feature is 20 insulin units.

If you use **TIME** as the low reservoir warning type and you deliver large boluses, the actual time remaining could be less than the warning time. The **TIME** low reservoir warning type is intended to let you know if you will have enough insulin while you are sleeping.

- 1 Go to the RESV WARNING TYPE screen.
Main > Utilities > Alarm > Low Resv Warning
- 2 Select **Insulin Units** or **Time** and press **ACT**.

WARNING: When the pump detects a low reservoir condition during a bolus or prime delivery, the alert will go off after the delivery is finished. Make sure to check the volume of your reservoir to ensure enough insulin is available.

a. For Insulin units:

In the WARNING UNITS screen enter the number of units you want remaining for the first warning, then press **ACT**.

The pump will alarm first when the specified units remain, then again when half that remaining amount is used.

b. For Time:

In the WARNING TIME screen enter the amount of remaining time you want the first warning, then press **ACT**.

The pump will alarm first when the specified time remains, then again one hour before empty.

Review daily insulin totals

The DAILY TOTALS screen provides a day-by-day history of the total amount of insulin that delivered for the past 31 days. This screen includes all bolus and basal amounts delivered midnight-to-midnight for each of the past 31 days. The Today line in the DAILY TOTALS screen shows the amount of insulin you delivered so far that day.

The insulin used to prime your pump is not included in the DAILY TOTALS screen. This amount is counted separately and shown in the PRIME HISTORY screen.

Question: Why should I review my daily totals?

Answer: Comparing your daily insulin deliveries to your blood glucose records helps you and your healthcare professional identify your optimal daily insulin rate(s).

Question: What is included in the daily totals?

Answer: Daily totals include all basal and bolus insulin deliveries and meter blood glucose information for that day.

Pump data management

The pump data management feature allows you and your healthcare professional to view and manage your basal and bolus insulin delivery, food intake, and BG data with averages. You can view the details of each day individually or you can average the data over a specified number of days (up to 31 days).

- **Daily totals** – The system automatically tracks certain types of information for you on a day-to-day basis. The daily totals are the totals for a single day.
- **Averages** – The system automatically calculates averages of certain types of information for you. There are two basic types of averages:
 - An average over a number of days (you select the number of days)
 - An average for a single day

The insulin delivery, food intake, and meter blood glucose information includes daily totals and averages, as described in the following sections.

Meter blood glucose information

The meter blood glucose information is calculated by using all of the automatic and manual meter blood glucose measurements that were received by the pump for the day, or number of days. This includes measurements that were manually entered into the pump during that time.

To view data for a single day:

- 1 Go to the DAILY TOTALS screen.

Main > Utilities > Daily Totals

Select a date and press **ACT**.

- 2 The BG AVG (Blood Glucose Average) screen displays. This screen shows:
 - your average blood glucose for the day
 - your high and low blood glucose levels for the day
 - total number of blood glucose values you entered into the pump for the day

Press  to view more information.

- 3 The INSULIN screen displays. This screen shows:
 - total insulin delivered for the day
 - total Basal and Bolus insulin delivered for the day
 - total percentage of each (Basal and Bolus) delivered for the day
 - total carbohydrates entered into the pump for the day (entered using the Bolus Wizard feature)

Press  to view more information.

- 4 The BOLUS screen displays. This screen shows:
 - total bolus insulin delivered for the day
 - total food bolus insulin delivered for the day and total percentage of food bolus insulin delivered for the day
 - total Corr (correction) bolus insulin delivered for the day and total percentage of corr bolus insulin delivered for the day
 - total man (manual) bolus insulin delivered for the day and total percentage of manual boluses delivered for the day

Press  to view more information.

- 5 The NUM BOLUS screen displays. This screen shows:
 - total number of boluses delivered for the day
 - total number of food only and correction only boluses delivered for the day
 - total number of food plus correction boluses delivered for the day
 - total number of manual boluses delivered for the day

To get back to the HOME screen, press  four times.

To view data over a number of days:



This procedure shows you how to view insulin delivery, food intake and meter blood glucose data for a selected number of days.

- 1 Go to the DAILY TOTALS screen.

Main > Utilities > Daily Totals

The DAILY TOTALS screen shows **Daily Average** selected.

Press **ACT**.

- 2 The DAYS TO AVERAGE screen displays. Select the number of days you want to average by pressing the  and the . Press **ACT**.

3 The AVG BG screen displays. This screen shows:

- the average of all blood glucose values entered into the pump for the number of previous days you selected
- the average high and low blood glucose values for the number of previous days you selected
- the average number of blood glucose values entered into the pump per day for the number of previous days you selected

Press  to view more information.

4 The AVG INS (average insulin) screen displays. This screen shows:

- the average total insulin delivered per day for the number of previous days you selected
- the average total basal and bolus insulin delivered and total percentage of basal and bolus insulin delivered per day for the number of previous days you selected
- the average total carbs entered into the pump per day (entered using the Bolus Wizard feature) for the number of previous days you selected

Press  to view more information.

5 The AVG BOLUS screen displays. This screen shows:

- the average total bolus insulin delivered per day for the number of previous days you selected
- the average total food bolus insulin delivered for the number of previous days you selected and the total average percentage of bolus insulin delivered for the number of previous days you selected
- the average total correction bolus insulin delivered per day and the total average percentage of bolus insulin delivered per day for the number of previous days you selected
- the average total manual bolus insulin delivered per day and the total average percentage of bolus insulin delivered per day for the number of previous days you selected

Press  to view more information.

6 The NUM BOLUS screen displays. This screen shows:

- the average total number of boluses delivered per day for the number of previous days you selected
- the average total number of food only boluses delivered per day for the number of previous days you selected
- the average total number of correction only boluses delivered per day for the number of previous days you selected

- the average total number of food plus correction boluses delivered per day for the number of previous days you selected
- the average total number of manual boluses delivered per day for the number of previous days you selected

To get back to the HOME screen, press  four times.

Personal reminders

Alarm clock

The alarm clock is a feature that allows you to set daily reminders for various events (8 max). The factory setting for this feature is off. The alarm clock can be useful to remind you when to check your blood glucose, eat, bolus, etc. When the alarm clock goes off, the message, ALARM CLOCK will appear. Press **ESC**, then **ACT** to clear the reminder.

- 1 Go to the ALARM OPTION screen.
Main > Utilities > Alarm Clock
- 2 Select **On/Set**. Press **ACT**.
- 3 Select **Add Alarm**. Press **ACT**.
- 4 Enter the hour (flashing). Press **ACT**.
- 5 Enter the minutes (flashing). Press **ACT**.
- 6 Repeat steps 3 through 5 to program additional alarm times. Exit the menus when you are done.

Remote control option

The factory setting for this feature is off. You may want to explore the remote option after you have become completely familiar with the basic functions of your pump. It is important that you consult with your healthcare professional before using this feature. Remote controls can be purchased from Medtronic Diabetes.

Refer to the remote control user guide for operating instructions.

NOTE: *The use of RF (radio frequency) devices with the pump reduces battery life.*

To use the remote control, these pump settings must be programmed:

- Remote Options = On
- Remote control ID code entered in pump (code is on back of remote)
- Easy Bolus = On

Turn on remote control option

WARNING: If there is a LOW BATTERY condition, the pump will not receive signals from the remote. To ensure the pump communicates with the remote control, make sure the pump does not have a low battery. (Replacing the low battery with a new battery will restore remote control function.)

- 1 Go to the REMOTE OPTION screen.
Main > Utilities > Remote Option
- 2 Select **On**, then press **ACT**.
- 3 The REMOTE ID MENU screen appears. Add, delete or review your remote ID as described in the next section. Exit the menus if you are done.

Add, delete, review remote control IDs

Each remote control has its own unique ID. Up to three different remote control IDs can be programmed in your pump. The remote control programming screens are very similar to those for the meter. Make sure to select **Remotes** when programming your remote control.

If you are not sure that your remote control ID is entered in your pump, check the REVIEW REMOTE ID screen. You must turn on the remote option to add, delete or review the remote control ID(s) programmed in your pump.

- 1 **Adding a remote ID**
 - a. Select **Add ID**, then press **ACT**.
 - b. Enter each of the six ID numbers found on the back of the remote control. Press **ACT** after each entry.
After you set the last number of the ID, the screen will return to the REMOTE ID MENU.
- 2 **Deleting a remote ID**
 - a. Select **Delete ID**, then press **ACT**.
 - b. Select the remote ID that you want to delete, then press **ACT**.
The selected ID is now deleted.

- 3 **Reviewing remote IDs**
 - a. Select **Review ID**, then press **ACT**.
 - b. The programmed IDs will show in the **REVIEW REMOTE ID** screen.
- 4 Exit the menus when you are done.

Block feature

Block restricts access to pump programming. The factory setting for this feature is off. Block is an important safety feature if the pump user requires someone else to maintain complete control of pump operation. When block is on, the remote control is used to deliver a bolus and suspend/resume the pump. Direct pump programming is limited to suspend, block, and selftest. You can, however, still view status-type screens (**STATUS**, **BOLUS**, **BASAL REVIEW**, **DAILY TOTALS**, etc.). Discuss what uses and settings are best for you with your healthcare professional. (You can order the remote control from Medtronic Diabetes.)

Turning block on

NOTE: *The vibrate alert-type is disabled when block is on.*

- 1 Go to the **BLOCK OPTION** screen.
Main > Utilities > Block
- 2 Select **On**, then press **ACT**. The **HOME** screen will appear with an open circle. The Block option is now on and the pump is in Special mode. Exit the menus.



Example 1: Block

Nicholas is a very active toddler who wears a Paradigm pump. His parents don't want to worry that he will play with the pump and accidentally change his programmed settings. They simply activated the Block feature, and now, except for the Suspend and Self-Test, no other features are active when using the pump buttons. When Nicholas needs a bolus, his parents and caregivers simply program it with the Remote Control.

Example 2: Block

Oscar is an elderly man with diabetes who needs assistance with all of his daily living activities. He needs his caregiver or family member to help him with his pump as well. To be sure that Oscar does not change any pump settings, his family programmed his Paradigm pump with the Block feature turned on. They use the Remote Control to give him his boluses when he needs them.

Lock keypad feature

Lock keypad prevents accidental pump keypad presses. You can only press the  to view the STATUS screen, and the  button to turn on the backlight. The remote control can be used to give a bolus or put the pump into Suspend.



A locked keypad is automatically unlocked during the following:

- Battery insertion
- Alarms
- Alerts

Locking the keypad

- 1 Go to the UTILITIES MENU.
- 2 Select **Lock Keypad**, then press **ACT**.
- 3 Press **ACT** again to lock the keypad. The **KEYPAD LOCKED** screen appears with instructions on how to unlock the keypad.

Unlocking the keypad

Press the  button and the  button at the same time. Keypad Unlocked screen appears.

Selftest

Selftest is a safety utility that allows you to check if your pump is operating properly. This self-diagnostic feature can be used for maintenance or to check your pump if it operates unusually. During selftest, your pump will automatically run internal tests, including a check for proper operation of the beep and vibrate modes. The selftest is additional to the routine tests that run independently while the pump operates.

Contact our 24 Hour HelpLine if any of the tests do not occur as described here.

NOTE: *If the pump detects a condition such as low battery, the selftest will not finish. A message will appear to show the condition that caused the test to stop.*

- 1 Go to the UTILITIES MENU.
Main > Utilities > Selftest
- 2 Select **Selftest**, then press **ACT**.
- 3 Periodically, you will hear beeps as different mechanisms in the pump are being tested. As part of the selftest, the pump will do these tests:
 - a. **Screen Test:**
The screen will appear all black.
 - b. **Selftest:**
The pump will count down from 10.
 - c. **Tone Test:**
You should hear beeps.
 - d. **Vibrate Test:**
You will feel vibrations.
- 4 After the selftest is finished, **TEST COMPLETE** screen appears. The screen will return to the UTILITIES MENU, then to the HOME screen.

User settings

The user settings function allows you to save, restore, and clear all pump settings. You can also view a listing of the dates and times of all recent user settings operations you have done. The Save Settings feature lets you keep a set of pump settings that you can restore to your pump if it is cleared or you need to go back to these settings for any reason.

When you clear your pump, the pump settings are restored to the factory defaults, and you must either use Restore Settings, if you have saved a set of pump settings, or reprogram all your settings before you can use your pump again. The pump does not clear the internal pump memory.

WARNING: Do not clear your pump settings while it is connected to your body.

CAUTION: Do not clear your pump settings unless directed by your healthcare professional or a Medtronic Diabetes representative. If you clear your pump settings, it will be necessary to reprogram all your personal pump settings as directed by your healthcare professional. Additionally, you will have to rewind your pump.

Saving the settings

Do these steps to save your current pump settings:

- 1 Go to the UTILITIES MENU screen and select **User Settings**.
Main > Utilities > User Settings
- 2 Hold down  and press **ACT**.
- 3 The USER SETTINGS screen is displayed with **Save Settings** highlighted. Press **ACT**.
- 4 If this is the first time you have saved pump settings, go to step 5. If you have previously saved pump settings, a message displays, indicating the date of your last pump settings save. Read the instructions on the screen, then press **ACT** to save your current settings. You can press **ESC** if you want to cancel the save.
- 5 The SETTINGS SAVED message displays to confirm that your current pump settings have been saved. Exit the menus.

Restoring the settings

Do these steps to restore the most recent pump settings you have saved to your pump.

- 1 Go to the UTILITIES MENU screen and select **User Settings**.
Main > Utilities > User Settings
- 2 Hold down  and press **ACT**.
- 3 The USER SETTINGS screen is displayed. Select **Restore Settings**, then press **ACT**.
- 4 A message displays, giving you the option of restoring the pump settings that were saved on the given date and erasing the ones currently on your pump. Read the instructions on the screen then press **ACT** to restore the settings. You can press **ESC** if you want to cancel the restore.
- 5 The SETTINGS RESTORED message displays to confirm that your current pump settings have been replaced with the pump settings you had saved on the given date. Exit the menus and check your pump settings to verify the restore.

Clearing the settings

Take the following steps only if you want to clear your pump to factory default settings.

WARNING: Do not clear your pump settings while it is connected to your body.

CAUTION: Do not clear your pump settings unless directed by your healthcare professional or a Medtronic Diabetes representative. If you clear your pump settings, it will be necessary to reprogram all your personal pump settings as directed by your healthcare professional. Additionally, you will have to rewind your pump.

- 1 Go to the UTILITIES MENU screen and select **User Settings**.
Main > Utilities > User Settings
- 2 Hold down  and press **ACT**.
- 3 The **USER SETTINGS** screen is displayed. Select **Clear Settings**, then press **ACT**.
- 4 A **CONFIRM** message displays, giving you the option of clearing your pump settings or not. Select **YES** and press **ACT** to clear the settings. You can press **ESC** if you want to cancel.
- 5 You will see a **RESET** screen, and then the pump will go through various screens while it restarts. After the pump clears all of your settings, the screen will go to the **TIME/DATE SETUP** screen.
- 6 Reset the time and date as described in *Setting the time and date* section of the *Basic programming* chapter.
- 7 After you set the time and date, you must rewind your pump. Refer to the *Rewinding your pump* section of the *Starting on insulin* chapter for instructions. Remember, all your settings have been cleared and you must either restore or reprogram all your settings.

History

If you want to view a listing of the dates and times of all recent **User Settings** operations you have done on your pump, such as saves and restores, take the following steps:

- 1 Go to the UTILITIES MENU screen and select **User Settings**.
Main > Utilities > User Settings
- 2 Hold down  and press **ACT**.
- 3 The **USER SETTINGS** screen is displayed. Select **History**, then press **ACT**.

- 4 The SETTINGS HISTORY screen displays, giving you a list of all the dates and times of your most recent User Setting operations. Scroll down to view the entire history. When you are done looking at the history, press **ESC** to exit the menu.

Therapy software

Medtronic provides software to optimize your pump use. Contact our 24 Hour HelpLine for more information.

CareLink Personal™

Your pump provides real-time glucose values so that you can track glucose concentration patterns and possibly identify episodes of low and high blood glucose. It also stores glucose data so that it can be analyzed to track patterns and/or downloaded to CareLink Personal for analysis of historical glucose values.

CareLink Personal is a web-based system designed to help you manage your diabetes. It has many key features:

- It copies (uploads) data from your devices: insulin pump and supported blood glucose meters.
- Device data is stored on a networked database.
- There is an online logbook where you can record self-reported information, such as how many carbohydrates you consumed.
- Uploaded data and other information stored on the system can be viewed through several different types of treatment reports.
- Access to data and personal information on this system is secure.

Reports

Reports show you data gathered from your device(s), and from what you directly entered into the system. Examples of the report data you can get include:

- Pump operation, such as alarm settings and maximum allowed bolus amount.
- Insulin delivery rates, types and times.
- Blood glucose reading levels and times.
- Bolus Wizard or online logbook entry data.

Reports are displayed in PDF format. They can be viewed online, saved, or printed.

You can share your reports with your healthcare professional. These reports can help you and your healthcare professional to discover trends and other information. This can lead to improved therapy management for greater control.

Logbook

The logbook allows you to enter the following self-reported information:

- Carbohydrates consumed
- Exercise activity
- Urine ketone results
- HbA1c results
- Infusion set changes

The data from your logbook is used in the reports you create. You can see how, for example, your carbohydrate intake compares to blood glucose levels for the same day or time. You can also use it as an online diary of your diabetes management.

Insulin pump therapy follow-up

We hope that you are now comfortable using the pump and your blood glucose values have improved through insulin pump therapy. Diabetes management requires much more than blood glucose control. You need to take care of your complete physical and mental health. This includes seeking treatment for any condition both directly related to and not related to diabetes. The following recommendations apply to general diabetes as well as insulin pump therapy follow-up. Remember, your healthcare professional is your best resource for successful diabetes management.

Recommended follow-up

Everyday

- Check blood glucose 4-6 times a day and always before bed
- Test before driving and have a fast-acting carbohydrate with you when you drive
- If your blood glucose is above 250 mg/dL (13.9 mmol/L) twice in a row, take an injection and change the infusion set

Every month

- Review DKA prevention guidelines
- Check 3:00 AM blood glucose at least once during the month
- Check 2-hour post-meal blood glucose for all meals on a given day

Every 3 months

- Visit your healthcare professional, even if you feel well and your blood glucose values are within target range
- Review your blood glucose log and insulin pump settings with your healthcare professional
- Make sure you have an HbA1c test done

Laboratory tests

- Test for HbA1c four or more times a year
- Test for cholesterol, HDL, LDL, triglyceride yearly
- Test for microalbuminuria yearly

Every visit

- Blood pressure check
- Foot exam
- Review goals for blood glucose, meal plan and exercise

Annually

- Dilated eye exam by a qualified ophthalmologist
- Annual flu shot
- Regular dental visits
- Nerve function tests
- EKG test over age 35
- Prostate exam for men, breast exam for women
- Diabetes education review
- Replace Glucagon Emergency Kit (new prescription from your healthcare professional)

Troubleshooting and alarms

This Troubleshooting chapter is designed to help you understand the messages that your pump is giving you when you get an alarm or an alert message. The procedures in the beginning of this chapter are to be used when you get specific alarms or cover a likely condition that might happen. A list of alarms is provided at the end of this chapter.

NOTE: *It is recommended that you read your warranty statement included with your pump for information on what is covered during your warranty period.*

My pump has a NO DELIVERY alarm

When a NO DELIVERY alarm occurs, it means the pump is working correctly. Your pump is not broken, but it has detected that something is preventing insulin from being delivered. Do the following steps:

- 1 Check your blood glucose and take an injection if needed.
- 2 Make sure that there is insulin in your reservoir and the tubing is not kinked. If these are all right, go to *step 5*.
- 3 If necessary unkink the tubing. Clear the alarm by pressing **ESC** and **ACT**. A screen will appear with two choices: **Resume** and **Rewind**. Select **Resume**.
- 4 If the reservoir is empty, clear the alarm by pressing **ESC** and **ACT**. Select **Rewind** and change your reservoir and infusion set per the instructions in the *Starting on insulin* chapter.
- 5 Continue troubleshooting by disconnecting at the quick-disconnect, and set a 10 unit Fixed Prime.
- 6 Does insulin come out of the needle at the quick-disconnect?
 - a. If yes, change your entire infusion set per the instructions in the *Starting on insulin* chapter. If NO insulin comes out of the needle at the quick-disconnect, or you receive another No Delivery alarm, call our 24 Hour HelpLine.
 - b. Your pump remembers the last Fixed Prime amount that was delivered, so make sure to set your Fixed Prime amount back to your usual setting. Remember to change your Fixed Prime amount from 10 units to your infusion set amount.
- 7 Monitor your blood glucose closely.
- 8 If you followed these steps and you are still receiving a No Delivery alarm, call our 24 Hour HelpLine.

What happens if I leave the pump battery out too long?

If you leave the pump battery out too long (more than five minutes) you may receive a BATT OUT LIMIT alarm message when you install the new battery. Do the following steps:

- 1 Set your pump clock to the correct time, date, and year.
- 2 Check to make sure that all your settings, such as basal rate, are set as desired. If need be, reapply your last saved settings to the pump by using the **Restore Settings** option under **User Settings** in the UTILITIES MENU (you can only use this option if you have previously saved your pump settings). See the *Restoring the settings* section of the *Utilities* chapter.
- 3 Check the ALARM HISTORY screen and the STATUS screen for any alarms and/or alerts that may still need attention.

If you leave the battery out for more than three or four days, you may receive an A17 and A47 alarms when you install a new battery. Do the following steps:

- 1 Clear the A17 and A47 alarms.
- 2 Set your pump clock to the correct time, date and year.
- 3 Check to make sure that all your settings, such as basal rate, are set as desired. If need be, reapply your last saved settings to the pump by using the **Restore Settings** option under **User Settings** in the UTILITIES MENU (you can only use this option if you have previously saved your pump settings). See the *Restoring the settings* section of the *Utilities* chapter.
- 4 Check the ALARM HISTORY screen and the STATUS screen for any alarms and/or alerts.

Why doesn't my pump battery last very long?

A short battery life does not mean that something is wrong with your pump. Battery life in your pump is variable and based on the conditions below:

- The brand of battery you use (we recommend Energizer).
- The storage and/or handling of the battery before use (avoid high or low temperatures).
- The usage of pump in cold temperatures; this may shorten the battery life.
- The usage of your pump, such as how often the buttons are pushed, the number of alerts/alarms and set changes.
- The amount of insulin the pump is delivering.
- The usage of some features. The backlight, vibrate, remote control and meter options decrease battery life.

What is a CHECK SETTINGS alarm?

This alarm occurs after an E alarm or after you clear your pump. It is advising you to make sure that all your settings are correct. A CHECK SETTINGS alarm occurs after any of these actions:

- All user settings were cleared (set back to their defaults) because there was an E-error alarm,
- The CLEAR SETTINGS function was performed,
- Or after you rewind when practicing without a reservoir when your first get your pump. In this case, it is just a reminder to make sure all your settings are programmed before you begin using the pump with insulin.

My screen appears distorted

The screen may appear distorted or have a rainbow-like appearance if you are wearing polarized sunglasses, are in bright sunlight, or in extreme high or low temperatures. If your screen appears distorted:

- Take off your sunglasses.
- Move into the shade.
- Make sure your pump is not in direct heat (next to a heater) or cold (worn on the outside of your clothing on a very cold day).
- **Do not return the pump:** this is a normal property of this type of screen on any device.

I cannot get out of the priming loop

There are several causes of and resolutions to this problem:

- 1 Is the reservoir pump full?
 - If no, place a full reservoir or shipping cap in the pump.
 - If yes, make sure you are disconnected from the pump.
- 2 Hold the **ACT** button until the second set of beeps and the numbers appear on the screen.
 - If yes, your pump is okay. Go to step 4 in the *Manual prime* section in the *Starting on insulin* chapter to finish the manual prime.
 - If you did not hear a second set of beeps or numbers did not appear on the screen, change your infusion set and repeat this step.
- 3 If you still do not hear the beeps and see the number count on the screen, call the helpline or your local representative.

The pump is asking me to rewind

This is normal after any of the following:



- 1 Any E-alarms,
- 2 The Clear Settings function,
- 3 Or, a NO DELIVERY Alarm (during the Prime sequence).

My bolus stopped

The Bolus Stopped error can occur if the battery cap is loose or the pump was bumped or dropped during a bolus. It can also happen if the pump receives a static shock. As a safety measure, the pump stops the bolus when this happens.

- 1 If you dropped your pump, visually inspect it to make sure that it is not damaged in any way.
- 2 Review your bolus history and reprogram the remaining bolus, if needed.

My pump buttons are not acting right during a bolus

If the ,  or  buttons are pressed and held down while a bolus is being delivered, the screen will freeze on that amount. Once the button is released, the units will ramp up to the amount delivered so far. Pressing and holding down the button will not stop the delivery of a bolus.

My pump will not display my blood glucose reading from my meter

- 1 Make sure you are using the correct meter (a blood glucose meter supported by MWT1 technology). Your pump will communicate with this meter only.
- 2 Make sure your meter's RF (radio frequency) feature is on and working correctly.
- 3 Make sure the meter option in your pump is set to **On** and you have set the meter ID number correctly on the pump.
- 4 Make sure your pump does not have a low battery alert condition.
- 5 Make sure the meter is within 4 feet (1.2 meters) of the pump without anything in between such as another person, a wall, etc.
- 6 Make sure there is no RF (radio frequency) interference from other electronic devices that could prevent communication. These devices can include some cell phones, cordless phones, televisions, computers, radios, other Paradigm pumps, meters and pump remote controls. To restore communication, simply move away from these other types of devices, or turn them off.

- 7 Your pump will not show another reading. Make sure the pump is idle and the HOME screen is blank.
- 8 If your pump still does not receive your blood glucose reading from the meter, use the up/down buttons to manually enter your blood glucose (in the ENTER BG screen).

I dropped my pump

Take care to protect your pump from being dropped.

- 1 Check that all connections are still tightly in place.
If you notice that the drive support cap is loose, or sticking out, discontinue use of the pump. **Do not press on the drive support cap. Pushing on the drive support cap may result in unintended insulin delivery, which can cause hypoglycemia.** See *Warnings* in the *Introduction* chapter for more information.
- 2 Check the LCD, keypad and pump case for cracks or damage.
- 3 Check infusion set, including the tubing connector and tubing for cracks or damage.
- 4 Review the status screen, basal rates and other pump settings.
- 5 Perform the Selftest procedure located in the UTILITIES MENU.
- 6 Call our 24 Hour HelpLine for assistance.

I submerged my pump in water

Your pump is designed to resist accidental contact with water. Do not submerge in water during bathing, showering, swimming, or other water activities.

- 1 Pat the outside of the case until dry.
- 2 Open the reservoir compartment and check the compartment and reservoir for water. If wet, dry it completely within ten (10) minutes of exposure to water. Exposure to liquids, including water or insulin can corrode the mechanism.
- 3 Dry the reservoir completely—do NOT place a wet reservoir in the pump.
- 4 Do not use hot air to dry your pump. This may damage your pump's internal electronics.
- 5 Check the battery compartment and the battery—if wet, let them dry completely before using the pump.
- 6 Perform a selftest.

I cannot get to the User Settings screen

If you press **ACT** when you have **User Settings** highlighted, the following message appears: This feature is not normally accessible. To access, consult your User Guide.

To get to the USER SETTINGS screen:

1 Go to the UTILITIES MENU screen.

Main > Utilities

2 Select **User Settings**. Hold down  and press **ACT**.

3 See the *User Settings* section of the *Utilities* chapter for information about the menu options.

Alert conditions

Your pump has a sophisticated network of safety checks and systems. If it detects an unusual condition that requires your immediate attention, it beeps or vibrates periodically to alert you. The pump goes into Special mode (an open circle displays), and the backlight illuminates.

If you do not clear an alarm, the pump will not display any other alarms or alerts. Your pump behaves differently if an alarm happens after an alert that has not been cleared. It will display an alarm before you clear the initial alert. Alarms and alerts are displayed in the order of importance. When you clear the initial alarm, the pump displays any alarms or alerts received after the first alarm in this order.

Check your pump and test your blood sugar. Follow the guidelines prescribed by your healthcare professional to manage your diabetes as needed.

Example:

John's pump displays a BUTTON ERROR alarm, but he does not clear it. During the time that his pump displays the BUTTON ERROR alarm, his pump receives a LOW RESERVOIR alert. A few minutes later, his pump receives a NO DELIVERY alarm. John's pump does not display the LOW RESERVOIR alert or the NO DELIVERY alarm until he clears the first alarm. After John clears the BUTTON ERROR alarm, his pump displays the LOW RESERVOIR alarm. After he clears the LOW RESERVOIR alarm, his pump displays the NO DELIVERY alert.

- Dual Wave or Square Wave bolus delivery
- Pattern A or B is active
- Temp basal delivery
- Block feature is on
- Low reservoir
- Low battery

Question: Why are alerts important?

Answer: Your pump monitors activities and will alert you if a Special mode is active. Some alerts are a normal part of pump therapy, such as an active temporary basal. There are alerts that indicate a condition that is outside normal pump activity. For example, your pump notifies you with an alert when you need to replace the reservoir (LOW RESERVOIR) or replace your pump battery (LOW BATTERY).

What to do

When your pump beeps or vibrates notifying you that an alert condition exists:

- 1 Read and follow the instructions on the screen. Press **ESC**, **ACT** to silence an alert.
- 2 Check the STATUS screen to determine what caused the alert.
- 3 If the condition is due to a low battery, replace the battery.
- 4 If the condition is due to a low reservoir, monitor the reservoir volume frequently and change the reservoir when appropriate. Make sure you have a new reservoir, infusion set and vial of insulin with you.

LOW RESERVOIR ALERT

You can program the pump to sound an alert when either a specified number of units remains or a specified amount of time remains before the reservoir will be empty.

LOW BATTERY ALERT

If you get this alert, DO NOT go to sleep without replacing the battery. The backlight, the remote, and meter functions are disabled during a LOW BATTERY condition. If the alert type is set to Vibrate, the pump will change to the audio alert Beep Medium. Clear (**ESC**, **ACT**) this alert before you replace your battery.

Alarms

Your pump has a sophisticated network of safety checks and systems. If the safety network detects anything unusual, your pump notifies you of conditions that require your immediate attention. The backlight illuminates the pump screen and the alarm/alert message displays on the screen.

If you do not clear an alarm, the pump will not display any other alarms or alerts. Your pump behaves differently if an alarm happens after an alert that has not been cleared. It will display an alarm before you clear the initial alert. Alarms and alerts are displayed in the order of importance. When you clear the initial alarm, the pump displays any alarms or alerts received after the first alarm in this order. See the example in the *Alert conditions* section of this chapter.

Check your pump and test your blood sugar. Follow the guidelines prescribed by your healthcare professional to manage your diabetes as needed.

NOTE: *The STATUS screen shows any alarms and alerts that are active.*

Question: Why are alarms important?

Answer: Your pump monitors activities and notifies you if there is an unusual pump status or your attention is required. When an attention alarm is active, INSULIN DELIVERY IS STOPPED and immediate operator interaction is required.

If the Vibrate mode is on, all alarms and alerts start as vibrations and then change to beeps. For your safety, if there is no response after ten minutes, the beeps change to a siren. The siren continues every minute until the alarm is cleared.

What to do

When an alarm is triggered, the pump goes into Attention mode (a solid circle displays) and an alarm message shows on the screen. The pump then defaults to the HOME screen. Do these steps when you get an alarm:

- 1 **View the alarm:** From the HOME screen, press any button to see the alarm message.
- 2 **Read all of the alarm text.** There are instructions on how to fix the alarm condition. (Press  to read more text, if available.)
- 3 **Clear the alarm.** Press **ESC** then **ACT** after you read the alarm instructions.
- 4 The HOME screen appears.
- 5 **Follow the instructions** that appeared with the alarm to fix the alarm condition.
- 6 **Check your settings** (i.e., time/date, basal, etc.) to make sure they are correct.

Alarm conditions

Alarms put the pump in Attention mode.

A (ALARM)

This alarm shows the letter A followed by two numbers. A-alarms cause all insulin delivery to stop. Your pump settings are retained. If this alarm repeats often, call our 24 Hour HelpLine for assistance.

AUTO OFF

Alerts you that no buttons were pressed during the time limit you set for the AUTO OFF DURATION feature, and so insulin delivery has been stopped.

BATT OUT LIMIT

Occurs if the battery has been out of the pump for more than five minutes. Verify that the pump time and date are correct. If not correct, go to the UTILITIES MENU and reset the date and time.

BOLUS STOPPED

If this alarm occurs, it is very important to check bolus history to review how much of the bolus was actually delivered. If necessary, reprogram a bolus with the amount not yet delivered.

BUTTON ERROR

Occurs if a button has been continually pressed for more than three minutes.

CHECK SETTINGS

When this alarm is active, you should check and/or reprogram your pump settings, including the time/date.

E (ERROR)

After receiving this alarm, note the error number then call our 24 Hour HelpLine for assistance. An error alarm will show the letter E followed by two numbers. E-alarms cause all insulin delivery to stop, the pump resets, and all your settings are cleared.

EMPTY RESERVOIR

There is no insulin in the reservoir. Change the reservoir immediately.

FAILED BATT TEST

The pump tests the voltage of each battery installed. This test ensures a battery with low voltage is not used. If the battery does not have enough voltage, this alarm will occur. The pump will not function and the battery must be replaced. (Always make sure that you install a NEW battery into the pump.)

MAX DELIVERY

This alarm alerts you when you have taken more insulin than expected based on maximum bolus and maximum basal rates.

MOTOR ERROR

Insulin delivery has stopped. This alarm occurs if your pump detects a motor error.

NO DELIVERY

Insulin delivery has stopped. This alarm occurs if your pump detects a blockage.

NO RESERVOIR

The reservoir is not inserted correctly or no reservoir has been inserted.

OFF NO POWER

The battery is dead. Replace battery immediately. Follow the directions on the screen. Check to make sure that the time is correct on the screen. Reset the time if necessary.

RESET

The Reset alarm triggers when pump settings are cleared because of one of these reasons:

- Pump settings were cleared (Clear Settings function) and settings have not been reprogrammed.
- A download attempt from the PC is incomplete. (The download function is applicable to the optional software feature. Refer to the software user guide for more information.)

WEAK BATTERY

The pump tests the voltage of each battery installed. If the battery voltage is less than full strength, this alarm may occur. The pump will operate normally, but the battery life will be shorter than expected. Always make sure to install a NEW battery in the pump.

Pump maintenance

It is recommended that you read your warranty statement included with your pump for information about what is covered during your warranty period.

Battery

The Paradigm pump uses a single 1.5 V AAA alkaline battery, size E92, type LR03. As a safety measure, Medtronic Diabetes has designed the pump to only accept a NEW battery. If you insert a used battery, the FAILED BATT TEST alarm may be triggered. Refer to the *Install battery* in *The basics* chapter for instructions.

The use of cold batteries causes erratic pump behavior. To prevent this, do not use batteries that have been in cold storage (i.e., in the refrigerator or your car in the winter). It takes several hours for these batteries to warm to room temperature.

Certain features on the pump use a lot of battery power. Your battery will need to be replaced more frequently if you use these features:

- Remote control
- Meter
- Backlight
- Vibrate alert type setting

CAUTION: It is recommended that you use a AAA Energizer battery. Do not use a rechargeable or carbon zinc battery in the pump. Do not remove the battery unless you are changing your battery (installing a NEW battery). Replace it within five minutes. If not replaced within five minutes, the screen may display an alarm message. Follow the instructions in the message and make sure the time and date are set correctly. Check that the battery is inserted correctly. If the battery has been installed backwards, remove the battery and install it properly.

Storage

If you have to remove and store your pump, it is recommended that you store it with the battery in place. Keep a record of your current basal rates. To preserve battery life, reset the basal rates to 0 (zero), turn off the remote and meter options, and set the Auto-off to dashes or zeroes.

Cleaning your pump

- 1 Use only a damp cloth and mild detergent mixed with water to clean the outside of your pump.
- 2 Rinse the pump with a clean cloth, dampened with clean water.
- 3 Dry with a clean cloth.
- 4 Never use organic solvents, such as lighter fluid, nail polish remover, or paint thinner to clean your pump.
- 5 Keep the reservoir compartment and battery compartment dry and away from moisture.
- 6 Do not use any lubricants with your pump.
- 7 Use a 70 percent alcohol wipe to disinfect your pump.
- 8 Use a dry clean cotton tip to remove any battery residue from the battery cap.
- 9 Use a dry clean cloth to remove any battery residue from the battery compartment opening.

Pump specifications

This section provides detailed information on specifications related to your pump. The safety features of your pump are individually listed and described.

Alarms and error messages

- Indicators: audible tone (beep) or vibration (silent)
- All alarms and errors show messages on the pump's screen and provide instructions on what to do. Unresolved alarms will escalate to siren mode for added safety.

Alarm history

Maximum records shown: 36

Audio frequency

Name	Frequency (+/- 25%)
Alarm	1850 Hz
Escalated alarm	2.5 kHz, followed by 3.2 kHz
Alert	1.8 kHz, followed by 2.1 kHz and 1.8 kHz

Backlight

- LCD (Liquid Crystal Display) type
- Time-out: 30 seconds

Basal

- Rate increments: 0.05 units/hour
- Delivery: 0.05 - 35 units/hour (maximum units: 35/hour)

- Factory maximum setting: 2.0 units/hour
- 3 patterns maximum, each with 48 rates

BG target

- Maximum targets: 8
 - Range: 60 - 250 mg/dL (3.3 - 13.9 mmol/L)
 - Warning limits: less than 90 or greater than 140 mg/dL (less than 5.0 or greater than 7.8 mmol/L)

Bolus delivery

- Fluid delivered/stroke: 0.05 u
- Fluid delivered/stroke: 0.5 μ L
- Time between/delivery strokes: 2 seconds
- Delivery rate (per minute): 1.5 u

Bolus history

Maximum records shown: 24

Bolus units

Increments: 0.1 units

Bolus Wizard feature

(see the end of this section for information)

Carb ratios

Maximum ratio settings	Range	Warning limits
8	3 - 150 grams/u	less than 5 or greater than 50 grams/u
	0.1 - 5.0 u/exch	less than 0.3 or greater than 3.0 u/exch

Carb units

- The food entry when using Bolus Wizard feature
 - grams: 0 - 300 (increments: 1 gram)
 - exchanges 0.0 - 20 (increments: 0.5 exch)

Daily totals

Maximum records shown: 31 days of data, maximum display: 999.95 units/day. Daily delivery accuracy: +0/-0.05 units.

Default screen

The HOME screen. For most screens, if no buttons are pressed for 30 seconds, the pump returns to this screen.

Delivery accuracy

- Delivery accuracy: +/-5 percent.
- Displacement (piston) accuracy: +/-2 percent.

Delivery Volume Accuracy Curve (-0.40%) Overall Error
(MMT-515 Model) Qualification Testing (0.01 ml/hr 06/28/04 S/N: 010264-B061): 23°C
MMT-326 Reservoir Lot: kd0203245, MMT-318 Infusion set Lot: 314453

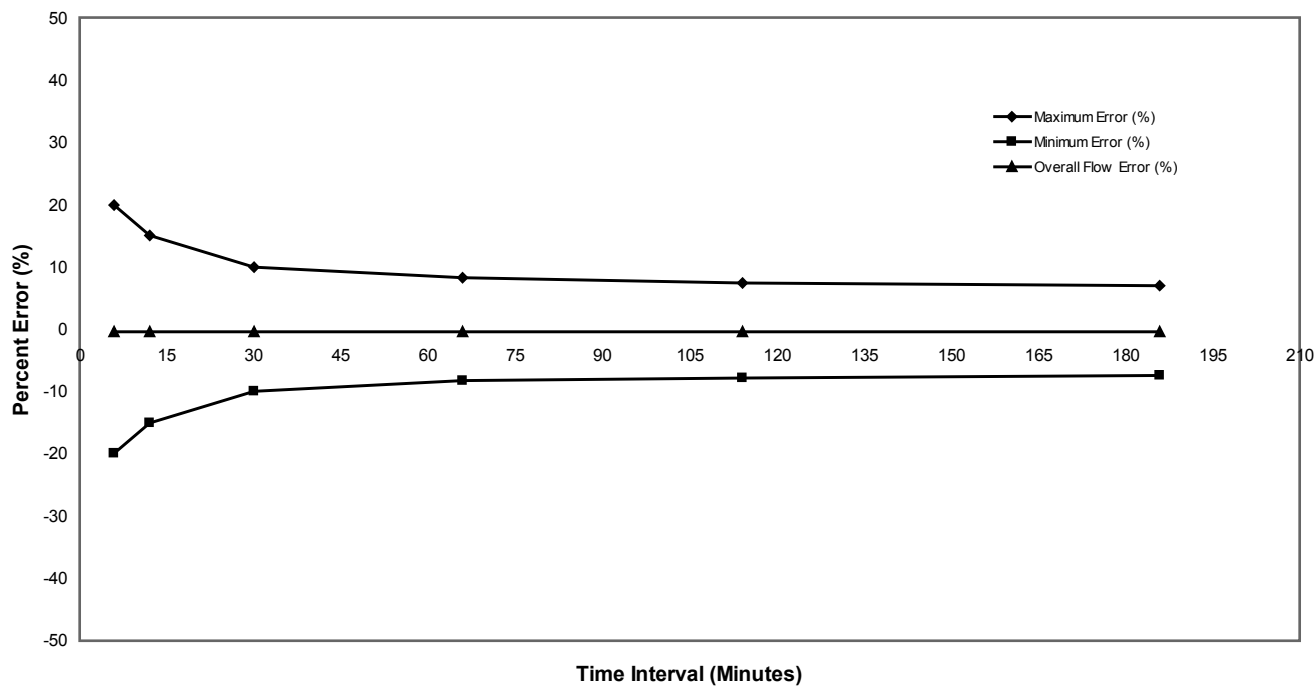

Pump motor

The pump motor has a unique, patented design with an integrated safety check system. The system delivers in precise increments.

Dual Wave bolus

Delivers a Normal bolus followed by a Square Wave bolus (limited by maximum bolus).

Easy bolus

- Features programming using audible tones (or vibrate pulses) in user-defined increments.
 - Beep mode range: 0 to maximum bolus
 - Vibrate mode range: 0 to 20 steps or maximum bolus, whichever comes first
- Default step increment: 0.1 unit
- Step size < maximum bolus.
- Adjustable step size: 0.1 to 2.0 units per step.
- Accessible from the remote control or pump buttons.

Infusion pressure

Maximum infusion pressure and occlusion pressure: 13.7 PSI (94.46 kPa).

Insulin sensitivity

- Maximum settings: 8
- Factory default: 50 mg/dL (2.8 mmol/L)
- Range: 10 - 400 mg/dL (0.5 - 22.2 mmol/L)
- Warning limits: less than 20 or greater than 100 mg/dL (less than 1.1 or greater than 5.6 mmol/L)

Low resv (reservoir) warning

Values are based on displayed amount, not actual amount.

time:	2 - 24-hours, and @ 1:00 hour before empty	08:00 hours (default when time is selected)
units:	5 - 50 units, and @ 1/2 amount remaining	20 units (factory default)

Meter value

- The BG measurement received from the meter. Appears in the ENTER BG screen during bolus programming. Appears on the screen when the pump is idle at the HOME screen.
 - Expiration: 12 minutes
 - Range: 20 - 600 mg/dL (1.1 - 33.3 mmol/L)
 - Maximum meter ID entries: 3

Normal bolus

Range 0.1 - 25.0 units of insulin (limited by maximum bolus setting).

Occlusion detection

When occlusion is detected, the NO DELIVERY alarm will occur. The occlusion alarm is triggered by an average of 2.77 units of missed insulin. The Paradigm pump is intended for use with U100 insulin. This table shows occlusion detection for 3 different situations when using U100 insulin.

Rate	Minimum time before alarm	Typical time before alarm	Maximum time before alarm
bolus delivery (1.5 u/min)	92 seconds	116 seconds	162 seconds
basal delivery (1.0 u/h)	2.2 hours	3.09 hours	4.47 hours
basal delivery (0.05 u/h)	37.4 hours	59.2 hours	87 hours

Percent temp basal

Default value: 100% of basal programming

Power supply

The pump is powered by a standard 1.5 V AAA alkaline battery, size E92, type LR03 (Energizer brand recommended).

Prime function

- Fixed prime range: 0.1 - 25.0 units (limited by maximum bolus)
- Manual prime limit: Warning at 30 units, then at each 10 units thereafter.
- Fill rate: 1 to 5 units/second.

Prime history

Maximum records shown: 20 manual and fixed

Program safety checks

Maximum infusion with single fault condition: 0.0 units

Pump size

The dimensions of the pump are approximately:

- 515 Pump:
 - 2.0 x 3.0 (2.8 at the battery cap) x 0.75 inches
 - 5.1 x 7.6 (7.1 at the battery cap) x 2.0 cm
- 715 Pump:
 - 2.0 x 3.7 (3.5 at the battery cap) x 0.75 inches
 - 5.1 x 9.4 (8.9 at the battery cap) x 2.0 cm

Pump weight

- 515 pump: approximately 100 grams (with battery installed).
- 715 pump: approximately 108 grams (with battery installed).

Remote control

Uses radio signals to allow users to program Normal boluses or to suspend/resume their pumps.

Reservoir

- The user-filled reservoir is made from impact-resistant, insulin-compatible polypropylene.
- 515 Pump volume: up to 176 units of U100 insulin
- 715 Pump volume: up to 300 units of U100 insulin

Square Wave bolus

Delivers bolus insulin over a duration of 30 minutes up to 8 hours (limited by the max bolus setting).

Temporary (temp) basal rate

Allows you to temporarily change the current basal rate for a duration of 30 minutes up to 24 hours (limited by maximum basal setting). The temp basal rate can be set to either Percent of basal or Insulin rate.

Time and date screen

12-hour or 24-hour formats. Pump users set the time/date, including the year, month and day. The date is included in the STATUS screen. Time always appears on the top of the screen.

Environmental conditions

- Pump operating temperature range: from 37°F (3°C) to 104°F (40°C)
- Air pressure range: from 700 hPa to 1060 hPa (from 10.2 psi to 15.4 psi)
- Operating humidity range inside the case: from 20% to 90% per EN 60601-1 2-24, Section 10.2.1c.

Status screen

Item	When	What
Active Insulin	if any	(Active Ins:) the amount of active insulin, displayed to the next 0.025U
Alarm Clock*	(appears if scheduled to alarm)	Time set is displayed.
Auto-off	(appears if enabled)	X HR
Basal pattern information	(if active)	Pattern A or B
Battery Status	(always appears)	Normal, Low, Off
BG meter value (most recent BG value received)	(appears if BG meter is enabled)	XXX m/dL time and date received
BG Reminder* (Only if enabled)	Time remaining before BG reminder is set to go off H:MM h (if less than 1 hour, 0:XXh where XX is minutes remaining)	
Block	(if active)	ON
Current date	(always appears)	
Current temp basal information	(if active)	rate (units per hour), duration, time remaining
Last alarm/alert	if cleared within 24 hours	(Last:) with the date, time and abbreviation for the most recently cleared alarm/alert
Last bolus information	type and units delivered delivery time and date	(S = Square, N = Normal, D = Dual)
Meter Off, Low Batt	(appears if enabled but battery is low or empty)	
Meter On	(appears if enabled)	
Pump model number	(always appears)	
Remote On	(appears if enabled)	
Reservoir started	(always appears)	date, time, units left, time left

Item	When	What
Serial number	(always appears)	
Software version	(always appears)	
Standard basal delivery data	(always appears)	current basal rate (basal 1, basal 2, etc.)
Status of pump	(i.e., Rewind, Suspended, Low Reservoir, Set Time, etc.)	
Time	(always appears)	
*If all of the Reminders and the Alarm Clock are enabled, only the reminder that is nearest to alarming will appear in the STATUS screen.		

Bolus Wizard feature specifications

There are three different formulas the Bolus Wizard feature uses to estimate a bolus, depending on your current BG. The following formulas apply only when the carb units are in grams.

- 1 If your current BG is greater than your High BG Target, the Bolus Wizard feature subtracts active insulin from the BG correction estimate, then adds this to the food estimate to get the total bolus estimate. However, if the result of subtracting active insulin from BG correction estimate is a negative number (less than zero), the total bolus estimate is based only on the food estimate.

$$\text{total bolus estimate} = \frac{\text{food}}{\text{carb ratio}} + \frac{\text{current BG} - \text{High BG Target}}{\text{insulin sensitivity}} - \text{active insulin}$$

(food estimate)
(correction estimate)

- 2 If your current BG is less than your Low BG Target, the Bolus Wizard feature adds the BG correction estimate to the food estimate to get the total bolus estimate.

$$\text{total bolus estimate} = \frac{\text{food}}{\text{carb ratio}} + \frac{\text{current BG} - \text{Low BG Target}}{\text{insulin sensitivity}}$$

(food estimate)
(correction estimate)

- 3 If your current BG is between or equal to your High or Low BG Target, the total bolus estimate is based only on the food estimate.

(food estimate)

$$\text{total bolus estimate} = \frac{\text{food}}{\text{carb ratio}}$$

- 4 If you do not enter a BG, the total bolus estimate is based only on the food estimate.

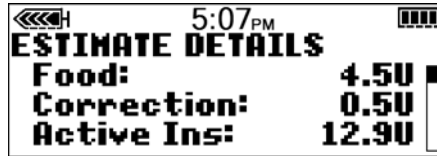

ESTIMATE DETAILS	
Food:	4.5U
Correction:	0.5U
Active Ins:	12.9U

Notes:

- If a Dual Wave bolus is less than the estimate due to the max bolus limit or a user change, the square (sq) portion is reduced first.
- Based on the Active Insulin Time setting you choose, the pump keeps track of how much insulin is still active in your body. This prevents the stacking of insulin, and lowers the chances of hypoglycemia.

- The Bolus Wizard feature may utilize your current BG measurement, carbohydrate consumption, and active insulin to calculate your estimated bolus.
- Active Insulin Curves

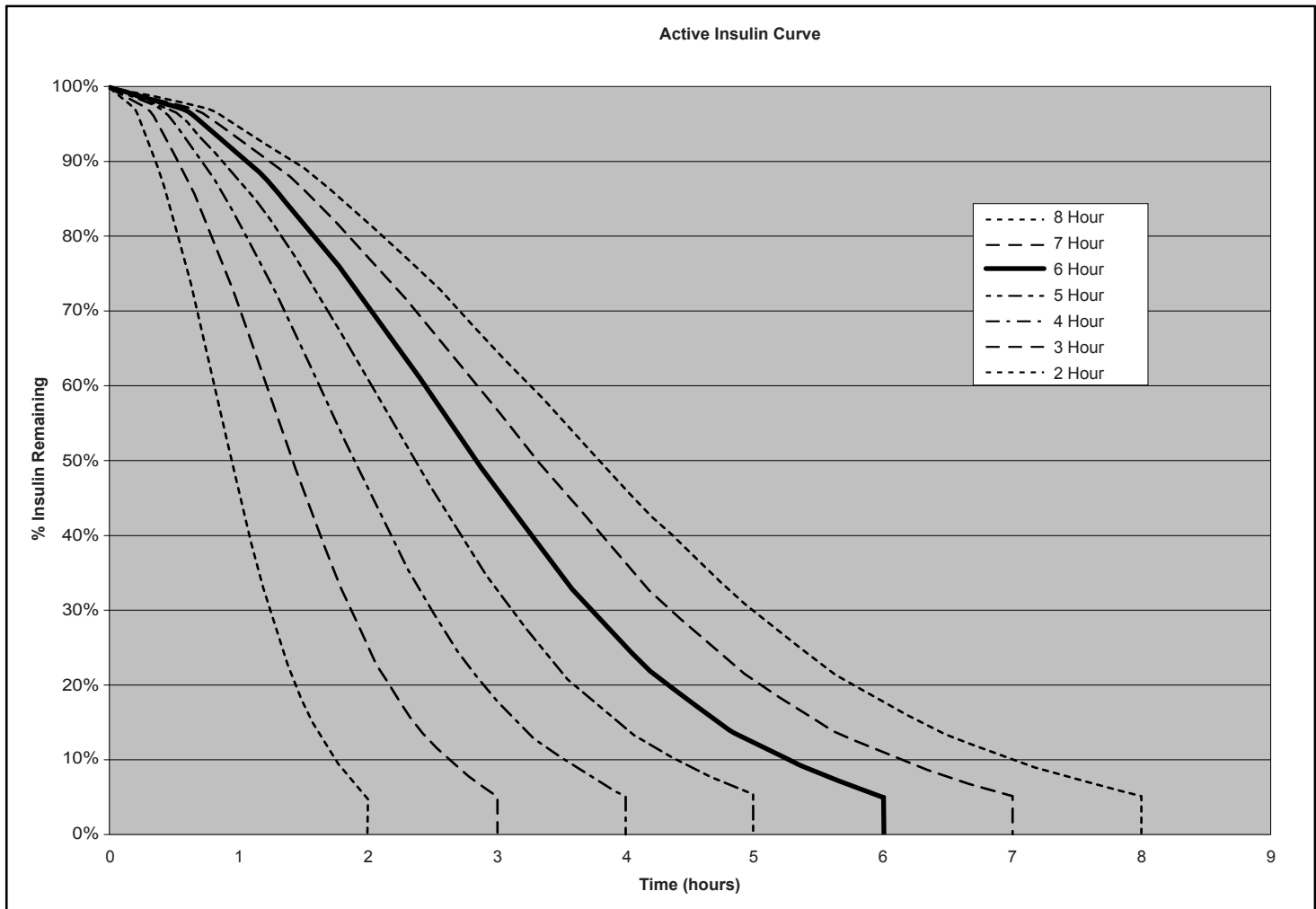

Graph adapted from Mudaliar and colleagues, Diabetes Care, Volume 22, Number 9 September 1999, page 1501

Bolus Wizard feature examples

Settings:

- Carb ratio: 30 grams/unit
- BG Target: 90-120 mg/dL (5.0-6.7 mmol/L)
- Insulin Sensitivity: 40 mg/dL/unit (2.2 mmol/L/unit)
- Active Insulin Time: 6 Hours

#1: No active insulin from previous bolus delivery. User inputs 60 grams of carbs and does not enter BG.

(food estimate)

$$\frac{60 \text{ g}}{30 \text{ g/u}} = 2 \text{ units}$$

bolus estimate = 2 units

#2: No active insulin from previous bolus delivery. User inputs 60 grams of carbs and a BG of 200 mg/dL (11.1 mmol/L).

(food estimate)

$$\frac{60 \text{ g}}{30 \text{ g/u}} = 2 \text{ units}$$

(correction estimate)

$$+ \frac{11.1 \text{ mmol/L} - 6.7 \text{ mmol/L}}{2.2 \text{ mmol/L/u}} = 2 \text{ units}$$

$$\frac{200 \text{ mg/dL} - 120 \text{ mg/dL}}{40 \text{ mg/dL/u}} = 2 \text{ units}$$

$$= 2 + 2$$

bolus estimate = 4 units

#3: No active insulin from previous bolus delivery. User inputs 60 grams of carbs and a BG of 70 mg/dL (3.9 mmol/L).

$$\begin{array}{rcl} \text{(food estimate)} & & \text{(correction estimate)} \\ \frac{60 \text{ g}}{30 \text{ g/u}} = 2 \text{ units} & + & \frac{3.9 \text{ mmol/L} - 5.0 \text{ mmol/L}}{2.2 \text{ mmol/L/u}} = -0.5 \text{ units} \\ & & \frac{70 \text{ mg/dL} - 90 \text{ mg/dL}}{40 \text{ mg/dL/u}} = -0.5 \text{ units} \\ & & = 2 + (-0.5) \\ \text{bolus estimate} & = & 1.5 \text{ units} \end{array}$$

#4: No active insulin from previous bolus delivery. User inputs 60 grams of carbs and a BG of 100 mg/dL (5.6 mmol/L).

$$\begin{array}{rcl} \text{(food estimate)} & & \text{(correction estimate)} \\ \frac{60 \text{ g}}{30 \text{ g/u}} = 2 \text{ units} & + & \text{Correction is 0 because the} \\ & & \text{current blood glucose reading} \\ & & \text{is between the BG High and} \\ & & \text{Low Targets} \\ & & = 2 + 0 \\ \text{bolus estimate} & = & 2 \text{ units} \end{array}$$

#5: Previous bolus activity results in a calculation of 1.5 units unabsorbed (active) insulin. User inputs 60 grams of carbs and a BG of 200 mg/dL (11.1 mmol/L).

<i>(food estimate)</i>	+	<i>(correction estimate)</i>	
$\frac{60 \text{ g}}{30 \text{ g/u}} = 2 \text{ units}$		$\frac{11.1 \text{ mmol/L} - 6.7 \text{ mmol/L}}{2.2 \text{ mmol/L/u}} - 1.5 \text{ units (active insulin)}$	= 0.5 units
		$\frac{200 \text{ mg/dL} - 120 \text{ mg/dL}}{40 \text{ mg/dL/u}} - 1.5 \text{ units (active insulin)}$	= 0.5 units
		= 2 + 0.5	
bolus estimate		= 2.5 units	

#6: Previous bolus activity results in a calculation of 3.5 units unabsorbed (active) insulin. User inputs 60 grams of carbs and a BG of 200 mg/dL (11.1 mmol/L).

<i>(food estimate)</i>	+	<i>(correction estimate)</i>	
$\frac{60 \text{ g}}{30 \text{ g/u}} = 2 \text{ units}$		$\frac{11.1 \text{ mmol/L} - 6.7 \text{ mmol/L}}{2.2 \text{ mmol/L/u}} - 3.5 \text{ units (active insulin)}$	= -1.5 units*
		$\frac{200 \text{ mg/dL} - 120 \text{ mg/dL}}{40 \text{ mg/dL/u}} - 3.5 \text{ units (active insulin)}$	= -1.5 units*
		= 2 + 0	
bolus estimate		= 2 units	

**This negative number indicates that active insulin is sufficient to cover the correction that is needed. Thus, correction will be 0 units. Active insulin does not reduce the food portion of the estimate.*

Insulin delivery default settings









Menu	Item	Default Setting	Limits	Increments
Bolus Menu:	Bolus Wizard feature:	Off		
	Easy bolus:	On		
	Easy bolus step:	0.1 u	2 u	
	Dual/Square bolus:	Off		
	Maximum bolus:	10.0 u	0 - 25 u (per single bolus)	
	BG reminder:	Off	0:00 - 5:00	0:30
Basal Menu:	Patterns:	Off		
	Maximum basal rate:	2.0 u/h	0.00 - 35.00 u/h	0.05 u
	Basal rate:	0.0 u/h		0.05 u
	Temp basal type:	U/H	max basal rate setting	0.05 u/h (or 1%)
Utilities Menu:	Lock Keypad:	Off		
	(Alarm) History:	(no defaults)		
	Alert type:	audio, beep-med		
	Auto-off:	Off		
	Low reservoir warning:	(20) insulin units	5 - 50 u; 2nd: @ 1\2 amount (2:00 - 24:00; 2nd: after 1:00)	20 u (0:30) (0:30 mins)
	(Time/Date) Time:	12 a.m. (midnight)		
	(Time/Date) Date:	1/1/04		

Menu	Item	Default Setting	Limits	Increments
	(Time/Date) Time format:	12-hour		
	Block:	Off		
	Alarm clock:	Off		
	Remote option:	Off		
	Meter option:	Off		
	User Settings:	(no defaults)		
	Language:	English		

Bolus Wizard feature default settings

Item	Default Setting	Limits	Increments	Warning Limits
carb units:	grams	none	none	none
ins to carb (or exch) ratio:	15 grams/u or 1 unit/exch	3-150 g/u or 0.1-5.0 u/exch	1 g/u or 0.1 u/exch	5 - 50 g/u or 0.3 - 3.0 u/exch
(insulin) sensitivity:	2.8 mmol/L or 50 mg/dL	0.5 - 22.2 mmol/L or 10 - 400 mg/dL	0.1 mmol/L or 1 mg/dL	1.1 - 5.6 mmol/L or 20 - 100 mg/dL
BG target:	5.6-5.6 mmol/L or 100-100 mg/dL	3.3 - 13.9 mmol/L or 60 - 250 mg/dL	0.1 mmol/L or 1 mg/dL	5.0 - 7.8 mmol/L or 90 - 140 mg/dL
Active Ins Time:	6 hours	2 - 8 hours	1 hour	

Icon table

Attention: See Instructions for Use	
Date of manufacture (year - month)	
Batch code	LOT
Catalogue number	REF
Device serial number	SN
Storage temperature range	
Magnetic Resonance (MR) unsafe	
Fragile product	
Type BF equipment (Protection from electrical shock)	
Conforms to IEC60601-1 sub-clause 44.6 and IEC60529 standard For more information about IPX7, see the <i>Glossary</i> on page 165.	IPX7
Recycle	
Radio communication	
Signifies compliance to Australian EMC and Radio communications requirements	

Signifies compliance with Industry Canada EMC and Radio communications requirements

IC

Warranty

Medtronic Diabetes warrants the Medtronic MiniMed Insulin Pump against defects in materials and workmanship for a period of 4 years from the date of purchase.

During the warranty period, Medtronic Diabetes will, at its discretion, either repair or replace (with a new or recertified pump, at Medtronic Diabetes' discretion) any defective pump or motor, subject to the conditions and exclusions stated herein. In the event that a pump is repaired or replaced, the warranty period will not be extended.

This warranty is valid only if the Medtronic MiniMed Insulin Pump is used in accordance with the manufacturer's instructions. This warranty will not apply:

- If damage results from changes or modifications made to the pump by the user or third persons after the date of manufacture.
- If damage results from use of non-Medtronic reservoirs and/or infusion sets.
- If damage results from service or repairs performed by any person or entity other than the manufacturer.
- If damage results from a *Force Majeure* or other event beyond the control of the manufacturer.
- If damage results from negligence or improper use, including but not limited to: improper storage, submersion in water or physical abuse, such as dropping or otherwise.

This warranty shall be personal to the original user. Any sale, rental or other transfer or use of the product covered by this warranty to or by a user other than the original user shall cause this warranty to immediately terminate. This warranty does not apply to Pathway pumps, batteries, infusion sets, reservoirs, and other accessories.

The remedies provided for in this warranty are the exclusive remedies available for any breach hereof. Neither Medtronic Diabetes nor its suppliers or distributors shall be liable for any incidental, consequential, or special damage of any nature or kind caused by or arising out of a defect in the product.

All other warranties, expressed or implied, are excluded, including the warranties of merchantability and fitness for a particular purpose.

Glossary

A

A1C (HbA1c) test - A 2-3 month average of blood glucose values expressed in percent. The normal range varies with different labs and is expressed in percent (such as 4 - 6%).

Accept - Pressing the **ACT** button to approve the selection or setting.

Active insulin - Bolus insulin that has been delivered to your body, but has not yet been used.

Alarm - Audible or vibrating (silent) notice that indicates the pump is in Attention mode and immediate attention is required. Alarms are prefixed in the alarm history with the letter A.

Alarm clock - Feature you can set to go off at specified times of the day.

ALARM HISTORY - Screen that displays the last 36 alarms/

errors that have occurred on your pump.



Alarm icon - a solid circle that shows at the top of the screen and the pump beeps or vibrates periodically until the condition is cleared (see Attention mode).

Alert - Audible or vibrating (silent) indicator that notifies you the pump needs attention soon or that you should be reminded of something. Insulin delivery continues as programmed.

Alert icon - an open circle that appears at the top of the screen and the pump beeps or vibrates periodically to remind you of the condition (see Special mode).

Attention mode - Operating mode that stops all current insulin delivery. This mode indicates an alarm or condition exists that requires immediate attention.

B

Backlight - Pump screen light. Turns on whenever the  button is pressed or in combination with the  button if not on the HOME screen. The backlight also appears during an alarm (except LOW BATT).

Basal rate - The pump setting that provides a continuous infusion of insulin to keep the blood glucose stable between meals and during the night. Basal insulin mimics pancreatic insulin delivery—which meets all the body's non-food related insulin needs.

BASAL REVIEW screen - shows the basal rates programmed in the pump, with the 24-hour total for each rate.

BG - Blood Glucose

BG reminder - Feature that you can set to remind you to

check your blood glucose after a bolus.

BG target - Normal blood glucose level

BG Units - Blood glucose units used by the pump (mg/dL or mmol/L).

Block - Feature that restricts access to all programming except suspend, selftest and the delivery of a bolus with the remote control.

Blood glucose (BG) - A form of digested sugar in the bloodstream. Glucose is the major source of energy for living cells, and is carried to each cell through the blood stream. Cells cannot use glucose without the help of insulin.

Bolus - A dose of insulin given to cover an expected rise in blood glucose (such as the rise after a meal) or to lower a high blood glucose down to target range.

BOLUS HISTORY - This screen displays the last 24 boluses delivered by your pump.

Bolus Wizard® feature - Calculates the bolus amount based on personal information of the pump user.

C

Calibrate - Check, adjust, or set to a standard (calibrate your pump).

Cannula - A short, thin, and flexible tubing at the end of the infusion set that is inserted into the subcutaneous tissue to deliver insulin.

Carb ratio - (Carbohydrate ratio). Used when counting carbohydrates in grams. The amount of carbohydrates covered by one unit of insulin. (Also see exch ratio.)

Carb units - The food entry when using the Bolus Wizard feature. Entered as (carbohydrate) grams or exchanges.

Carbohydrate - One of the three main sources of energy or calories in food. Carbohydrates are mainly sugars found in fruits, milk, and starches that the body breaks down into glucose.

CH - Carbohydrate

Contraindication - A condition that makes a specific treatment or procedure NOT advisable. A contraindication is literally contra- (against) an indication, against something that is indicated as advisable or necessary.

Correction bolus - The amount of insulin needed to return a high blood glucose level back down to target range.

D

Daily totals - Shows the total insulin delivered (basal and bolus) in the last 24-hours. Maximum records: 14 days

Default - A setting or value for your pump that is assigned automatically by your system. Some default settings cannot be changed; other default settings remain in effect until you change them.

Diabetic Ketoacidosis (DKA) - A serious condition that occurs when the insulin levels are low, blood glucose level are elevated, and the body uses fat for energy. This process produces ketones which upset the body's acid-base balance leading to a potentially life threatening situation.

DKA - Diabetic Ketoacidosis

Dual Wave™ bolus - Combination of a Normal bolus that is delivered immediately, then followed by a Square Wave bolus. The Square Wave portion is delivered evenly over a period of time.

Duration - Amount of time it takes to administer a bolus or basal delivery. Also, length of

time for an action or condition.

E

Easy bolus™ - Method of delivery for a Normal bolus using the Easy Bolus button .

Electromagnetic compatibility - The condition that exists when systems and devices that use electromagnetic energy operate properly without causing or suffering accidental electromagnetic interference to or from other electromagnetic devices.

Electrostatic discharge - The rapid, spontaneous transfer of electrostatic charge induced by a high electrostatic field. The charge usually flows through a spark, known as static discharge, between two objects at different electrostatic levels as they approach each other (for example, when people touch each other after dragging their feet on a carpet).

Exch ratio - (Exchange ratio) Used when counting carbohydrates as exchanges. The amount of insulin required to cover one (1) carbohydrate exchange. (Also see carb ratio.)

Exchange system - A system of estimating carbohydrate and calorie intake that groups by

type. Each exchange group lists similar types of food in serving sizes. A person can exchange, trade, or substitute a food serving in a particular group for another food serving in the same group.

Express bolus - Method of delivery for any bolus type using the express bolus button .

F

Fats - One of the three main classes of foods and a source of calories or energy in foods. Fats help the body use some vitamins and keep the skin healthy.

Fiber - A substance found in foods that comes from plants. Fiber may help in the digestive process and is thought to lower cholesterol and help control blood glucose. Fiber grams are not absorbed, and can be subtracted from the Total Carbohydrate amount for foods or meals with more than 5 grams of fiber.

Fingerstick - One method used to test blood glucose by taking a sample of blood for testing from a finger using a lancet or automatic finger puncture device.

Fixed prime - Fills the cannula with insulin. This is done after

you insert the infusion set into your body and remove the introducer needle.

Food bolus - A dose of insulin given to cover the expected rise in blood glucose that occurs after eating.

G

Gastroparesis - A condition of the digestive system that slows down the emptying of food from the stomach.

Glucagon - A hormone that raises the level of glucose in the blood. The alpha cells of the pancreas make glucagon when the body needs to put more sugar into the blood. Glucagon primarily causes sugar stored in the liver to be released into the blood stream.

Glucagon Emergency Kit - An injectable form of glucagon that can be used to treat severe low blood glucose levels (hypoglycemia). A Glucagon Emergency Kit can be obtained in a pharmacy with a prescription.

Glucose tablet - A simple sugar in tablet form, that is taken orally to treat low blood glucose (hypoglycemia). Glucose tablets can be purchased from the Medtronic Diabetes online store at www.medtronicdiabetes.com

as well as drug stores and pharmacies.

H

HbA1c - Glycosylated hemoglobin

HDL - High-density lipoprotein A complex of lipids and proteins in approximately equal amounts that functions as a transporter of cholesterol in the blood.

Hold - Press and continue to press a pump button.

Hyperglycemia - A condition in which blood glucose values are elevated above target. Symptoms may include excessive thirst, frequent urination, dry mouth, headache, fatigue, and blurred vision.

Hypoglycemia - A condition in which blood glucose values are low below 3.9 mmol/L (70 mg/dL). Symptoms may include behavioral changes, pale complexion, hunger, sweating, sudden weakness, headache, confusion, drowsiness, non-responsiveness to questions, and the most serious: seizure, convulsion or loss of consciousness.

I

Idle - The pump is at the HOME screen.

Increment - A small increase or decrease in a measurement.

Indication - A condition that makes a specific medical treatment or procedure advisable or necessary.

Infusion set - Flexible tubing with a reservoir connector and an infusion site. This tubing delivers insulin from the pump to the body.

Infusion site - The end of the infusion set held to the body with a tape. It consists of a cannula and an introducer needle.

Insulin - A hormone that helps the body use glucose (sugar) for energy. The beta cells of the pancreas make the insulin.

Insulin sensitivity - The amount by which your blood glucose (BG) level is reduced by one unit of insulin. (Bolus Wizard feature data)

Insulin to carbohydrate ratio - The amount of insulin required to cover a given number of carbohydrates. This ratio helps you estimate what size bolus you should take when eating carbohydrates. Your healthcare professional will

determine your insulin to carbohydrate ratio.

Introducer needle - This needle allows the insertion of a cannula into the subcutaneous tissue. It is removed and discarded after insertion leaving only the cannula in the body.

IPX7 - Protected against water immersion. Immersion for 30 minutes at a depth of up to 1 meter.

K

Ketone - A chemical created by the human body when there is not enough insulin in the blood.

kPa (kilopascal) - A unit of measurement for quantifying force. Used to measure atmospheric pressure. Equivalent to 10,000 dynes per square centimeter.

L

LDL - Low-density lipoprotein A complex of lipids and proteins, with greater amounts of lipid than protein, that transports cholesterol in the blood.

Link - To turn on and setup the meter option that allows the pump to receive BG readings from a meter that

communicates with your pump.

Log - A record of measurements, alarms or other actions by your pump.

Low resv warning -

Programmable warning that notifies you with an alert when either a specified number of units remain in the reservoir or a specified amount of time remains before the reservoir will be empty.

M

Manual bolus - Selectable item available in the BOLUS MENU when the Bolus Wizard feature is active. It is one method of programming a bolus without the Bolus Wizard feature. (see *Set bolus*)

Manual prime - Fills the infusion set tubing with insulin before you insert the set into your body. (This function is available after a rewind)

Max basal rate - The maximum amount of basal insulin that the pump will deliver at one time. (set by the user)

Max bolus - The maximum amount of bolus insulin that the pump will deliver at one time. (set by the user)

Meter - An optional blood glucose meter powered by

MWT1 technology. Your pump can be programmed to receive your BG readings from this meter.

Meter option - Feature that allows the pump to receive BG readings from a meter powered by MWT1 technology.

Mineral - Minerals and vitamins are essential micronutrients, needed in very small amounts to keep our bodies functioning properly.

MWT1 technology - MWT1 is the wireless Radio Frequency (RF) technology that is used to transmit information from the meter to the pump. You can program your pump to automatically receive your BG reading from this meter.

N

Normal bolus - An immediate delivery of a specified unit amount of insulin.

Normal mode - Regular operating mode. No special features are active, no alert or alarm conditions exist. Insulin delivery is normal during this mode.

Now portion - The normal portion of a Dual Wave bolus. The now portion delivers immediately and is then followed by the Square portion.

Nutrition - The process by which the body draws nutrients from food and uses them to make or mend cells.

Nutrition label - Used to determine the nutritional content of foods, as well as calories, carbohydrates, fats, proteins, vitamin and mineral content.

Nutritional content - The breakdown of nutrients found in a particular food.

P

Pattern feature - Extended pump feature that allows you to program optional basals (Pattern A, Pattern B) that support activities that are not a part of your day-to-day routine, but are usual in your lifestyle. Such activities could be a sport that you do once a week or a change in your sleep pattern over the weekend.

Pattern, standard - Your normal basal that supports your usual day-to-day activity. When the Patterns feature is off, the pump uses your standard (basal) pattern.

Post-prandial reading - Blood glucose reading taken after a meal

Press - To push and release a button.

Protein - One of the three main sources of energy or calories in food. Proteins are made of amino acids, which are called the building blocks of the cells. The cells need proteins to grow and to mend themselves. Protein is found in many foods such as meat, fish, poultry, and eggs.

PSI - Pound-force per square inch.

Pump S/N - Pump S/N is the serial number of the pump currently in use.

R

Reservoir - The syringe that holds insulin.

Reset - To set again, or change the information (reset your glucose values).

Resume - Restarts basal delivery after the pump is suspended.

Rewind - The pump drive moves back to its starting position to prepare the pump for a new reservoir.

RF - Radio frequency

S

Scroll - Press the up or down arrow buttons to move through the screen text.

Select - Pressing the up or down arrow buttons to highlight a desired screen item.

Sensitive - Easily irritated (sensitive skin), or able to measure very slight differences (a sensitive instrument).

Set - To enter or establish a value for your pump (set your Basal Reminder).

Set bolus - Selectable item available in the BOLUS MENU when the Bolus Wizard feature is inactive. One method of programming a bolus without the Bolus Wizard feature. (See *Manual bolus*.)

S/N# - Serial number.

Sodium - Is an essential element for your body. As table salt, it is used freely in foods as a flavor enhancer and a preservative. Sodium is listed on food labels and is expressed in milligrams.

Special mode - Operating mode that indicates one or more special functions is active or a condition exists that requires attention.

Square Wave™ bolus - Immediate bolus delivered evenly over a specified time period (30 minutes to 8 hours).

Square Wave portion - (Sq) The second part of a Dual Wave bolus. The Square Wave

portion delivers evenly over a period of time after the NOW portion delivers.

Status - The condition of a part of your system (battery status, alarm/alert status).

Status screen - Displays the current operations of the pump, including active functions, the most recent basal and bolus deliveries, reservoir information, and battery condition.

Step - Measurement of insulin that you set and use for Easy Bolus and other bolus deliveries.

Submerge - To place under water or cover completely with water.

Suspend - Function that stops all insulin delivery. Any current bolus and/or prime deliveries are cancelled. The basal delivery is paused until restarted.

T

Temp - Temporary

Temp basal - (Tmp basal) Temporary one-time basal insulin with a specified amount and duration. Used to support insulin needs for special activities or conditions that are not part of the normal daily routine.

Timeout - If you do not enter information or do something in a specific length of time, your pump automatically stops what it is doing and goes to the HOME screen.

M

μL - microliter

Index

A

- accessories 3
 - activity guard 3
 - CareLink USB 3
 - holster 3
 - leather case 3
 - meter 3
 - pump clip 3
 - remote control 3
- active insulin 82
- Active insulin time
 - setting 83
- alarm clock 117
- Alarm conditions 137
- alarm frequency 143
- ALARM HISTORY screen 111
- Alarm types
 - A (alarm) 137
 - Auto off 137
 - Batt out limit 137
 - Bolus stopped 137
 - Button error 137
 - Check settings 131, 137
 - E (error) 138
 - Empty reservoir 138
 - Failed batt test 138
 - Max delivery 139
 - Motor error 139
 - No delivery 129, 139
 - No reservoir 139
 - Off No power 139
 - Reset 139
 - Weak battery 139
- Alarms
 - responding to 136
 - review 111
- alert frequency 143
- alert type
 - Setting your 111
- alerts
 - for alert conditions 135
 - low reservoir alert 135
- areas
 - inserting infusion set 65
- Attention mode 32
- auto-off 112

B

- beep/vibrate, alert type 31
- BG reminder 47
- BG targets 81
- BG units 79
- Block feature 119
 - Turn on 119
- BLOCK OPTION screen 119
- bolus
 - basic 40
 - details 46
 - history 45
 - manual 92
 - maximum limit 47
 - stop delivery of 53
- bolus delivery
 - Easy Bolus 97
- bolus delivery, methods for
 - normal
 - Bolus Wizard 85
 - remote control 3
- BOLUS MENU 33
- bolus types
 - Dual Wave 91
 - Normal 40
 - Square Wave 91
- Bolus Wizard
 - about 73
 - estimate details 46
 - how it works 77
 - maximum delivery 77
 - on/off 78
 - review settings 83

settings 74, 75, 76
 Active insulin time 76
 BG target range 76
 BG units 75
 Carb ratios 74
 Carb units 74
 Insulin sensitivity 75
 specifications 152
 your BG reading 73
buttons, pump 25, 28

C

Carb units 78
carbohydrate counting 20
CareLink Personal 125
CareLink USB 3
CHECK BG message 48
cleaning the pump 142
Clear settings 123
consumables 2
correction bolus 40, 85, 86

D

Daily totals 114
DAILY TOTALS screen
 Review 113
default settings
 insulin delivery 158
Dual Wave bolus programming
 with Bolus Wizard 95
 without Bolus Wizard 92
dual/square option
 on-off 92

E

Easy bolus 97
 cancel 99
 deliver an 98
 step value 98
emergency kit 2
ESC 4
 cancels programming 34
express bolus button 28

F

filling
 reservoir 58
food bolus 40, 74, 77, 85, 86
food entry 74, 86
food label 21
frequency
 alarm 143
 alert 143

H

high BG levels
 Bolus Wizard and 77
history
 alarms 111
 bolus delivery 44
 user settings 123
HOME screen 29

I

infusion set 2, 57
 changing your 61
 inserting 65
 best sites 65
 rotating sites 65

Insulin sensitivity 80

L

Language setting 39
Lock keypad feature 120
low battery
 affects meter option 84
 affects remote control 118
 affects selftest 121
 affects your alert type 111
low BG levels
 Bolus Wizard and 77
low reservoir alert 135
Low resv warning feature 112

M

MAIN MENU 33
manual
 prime 64
maximum bolus limit 47
menus 33
meter 3, 73
meter IDs
 add, delete, review 85
meter option 83
 rules 84
METER OPTION screen 85
modes
 Attention 32
 Normal 32
 Special 32
MWT1 3
MWT1 technology 73

N

no delivery 129

Normal Bolus
 with Bolus Wizard 85
 without Bolus Wizard 40
 Normal mode 32
 Now 96
 Now portion
 of the Dual Wave bolus 93, 96
 nutrition 19

P

Patterns
 basal 100
 on/off 100
 pattern A, B 100
 Program a basal pattern 101
 Select a basal pattern 102
 standard basal pattern 100
 Personal reminders 117
 personal settings 74
 practicing 62
 prime
 manual 64
 PRIME MENU 34
 pump
 battery compartment 25
 buttons 25, 28
 if you remove your 35
 screen 25, 29
 using in water 133
 warranty 163

R

Reminder, alarm clock 117
 remote control 3
 remote control IDs
 add, delete, review 118
 Remote control option
 turn on 118
 removing your pump 35

reservoir
 filling the 58
 inserting in your pump 62
 low reservoir warning 112
 plunger rod 59
 removing the 61
 transfer guard 59
 tubing connector 25

reservoirs 2
 Restore settings 122
 rewinding your pump 62
 during practice 62
 RF features
 meter 83
 remote control 117
 use on aircraft 7

S

Save settings 122
 scroll bar 31
 Selftest 120, 133
 Special mode 32
 Square portion
 of the Dual Wave bolus 96
 Square Wave bolus programming
 with Bolus Wizard 95
 without Bolus Wizard 92
 STATUS screen 34
 Step value setup 98
 supplies, ordering 3
 Suspend function 33, 53

T

Temp basal 134
 Canceling a 108
 Deliver a 107
 rates 103
 Selecting type 107
 verify delivery 108

temp basal types
 Insulin rate 104
 Percent of basal 105
 terms and symbols 4
 therapy follow-up
 Recommended 127
 time and date, setting 37

U

User settings 121
 User Settings menu 133
 Utilities 111
 UTILITIES MENU 34

W

warranty 163



THE MINIMED
Paradigm[®]
INSULIN PUMP