

\*Due to production changes, the photos in this Assembly Manual and Setup Guide may differ from the actual production model. Body shell supplied clear with decals.

# X CRAWLER

## EP SUPER CLASS CRAWLER ARR



# ASSEMBLY MANUAL AND SETUP GUIDE

### X-CRAWLER EP SUPER CLASS CRAWLER ARR FEATURES AND SPECIFICATIONS

- Super Class Size, Almost-Ready-To-Run
- Machined Aluminium Gearboxes and Axle Carriers
- Ball Bearing Supported, Steel Drive Train
- Machined Aluminium Steering Knuckles

Before operating your new XTM Racing X-Crawler EP Super Class Crawler ARR, please read and understand the warnings listed on the next page. Failure to do so could lead to injury and/or property damage.

The XTM Racing X-Crawler EP Super Class Crawler ARR is not intended for persons under 14 years of age, unless closely supervised by an adult.

- Machined Aluminium Bead Lock Wheels
- Adjustable, Heavy-Duty Metal Steering and Suspension Links
- Machined Aluminium Shock Mounts
- Threaded Aluminium, Oil-Filled Shocks
- Clear Gear Covers
- Machined Aluminium Servo Mounts
- Aggressive Moulded Rubber Tyres with Inserts
- Designed for Dual Motors and Servos for Precise Manoeuvres
- Steel Hex Screws Throughout
- Extensive Parts Support and Support Forum

#### DISTRIBUTED IN NORTH AMERICA BY:

Global Hobby Distributors  
18480 Bandilier Circle  
Fountain Valley, CA 92708



#### DISTRIBUTED IN EUROPE BY:

Ripmax Ltd.  
241 Green Street  
Enfield, EN3 7SJ, U.K.



All Contents Copyright © 2008, XTM Racing - All Rights Reserved  
Version 1 July 2008

• Length .....	565mm/22.25"
• Width .....	385mm/15.15"
• Height (without Body Shell) .....	215mm/8.46"
• Wheelbase .....	395mm/15.55"
• Tyre Diameter .....	170mm/6.7"
• Weight .....	4.4Kg/9.7lbs

## TABLE OF CONTENTS

Safety Warnings - Please Read Before Proceeding.....	2
Customer Service Information.....	3
Introduction.....	3
Rock Crawling Information Sources.....	3
Recommended Accessories.....	4
Recommended Tools and Supplies.....	5
Parts Identification.....	5
Becoming Familiar with Your X-Crawler EP Super Class Crawler ARR....	6
Assembly Tips From the Pros.....	6
Final Assembly.....	7~12
Chassis Setup Guide.....	13~16
Replacement Parts and Assembly Drawings.....	16~23
Applying The Decals.....	24~25
Important Warranty Service Information.....	Back Cover
Warranty Information.....	Back Cover



contact us  
part of the Global family of brands

RC Trucks  
Engines  
Tires & Wheels  
Full Parts List  
Forums  
Full Product List  
Find Local Dealers  
Contact Us

Welcome to XTM! At XTM, radio control is a passion as well as a quest. This site is our collection of the vehicles, engines, and accessories that are available from XTM to satisfy your hunger for the radio control car hobby.

At XTM, we consider the customer to be the most important part of our designs and decision making. This is most evident in the on-line forums that we have created for our customers. These forums allow our present and future customers to ask us questions and converse with other customers and friends about the XTM products and others. Check it out at <http://globalservices.globalhobby.com>

At XTM, we are always trying to stay one step ahead. What's in store for 2007 you ask? Well, stick around and see where our passion leads us next! Get your FREE XTM Catalog - Sign Up today for the catalog and special promotions!

**VISIT US ON THE WEB AT**  
**[WWW.TEAMXTM.COM](http://WWW.TEAMXTM.COM)**

## SAFETY WARNINGS - PLEASE READ BEFORE PROCEEDING

### GENERAL WARNINGS

- Under no circumstances should you operate your model in crowds of people. Serious injury could result.
- Never operate your model on busy streets or if there are cars present.
- Do not use your model to chase pets or other animals.
- Periodically check all of the fasteners to ensure that they're tight. Use threadlock on all screws that thread into metal to help keep the screws from loosening due to vibration and normal use.
- Each time you use your model, first check the throttles and brakes to ensure that they're working properly.
- Clean and double-check everything on your model after each day of use to ensure top performance and reliability.

### BATTERY PACK WARNINGS

- Always follow the directions provided with your battery charger to charge your battery pack correctly.
- Periodically check your battery pack for excessive heat build-up during the charging process. If the battery pack is hot to the touch, remove it from the charger and let it cool. **Never leave your battery pack unattended during the charging process.**
- Always allow your battery pack to completely cool before recharging.
- Never over-charge your battery pack or serious damage to the battery pack and/or injury to the user could result.

### RADIO CONTROL SYSTEM WARNINGS

- When turning on your model, always turn on the transmitter before turning on the receiver (or plug in the battery pack if your Electronic Speed Controllers (ESCs) don't feature an ON/OFF switch).
- When turning off your model, always turn off the receiver (or unplug the battery pack if your ESCs don't feature an ON/OFF switch) before turning off the transmitter.
- Always unplug the battery pack when you're not using your model.
- Never cut the receiver antenna shorter or you could lose control of your model.
- When operating your model, make sure the transmitter antenna is completely extended.
- Because your model is operated by radio control, it is important to make sure you are always using fresh and/or fully charged batteries (if using NiCDs or NiMHs). Never allow the batteries to run low or you could lose control of your model.
- To ensure that your radio control system is operating properly and to prevent any chance of a runaway model, your radio control system should be range checked before the first run of the day and/or after a crash.

## CUSTOMER SERVICE INFORMATION

If you should have trouble with any of the steps listed in this Assembly Manual and Setup Guide, or if you find any missing or damaged parts in your kit or require additional information, please contact your local distributor at the address below:

### In North America:

**Global Services**  
18480 Bandilier Circle  
Fountain Valley, CA 92708

Phone: (714) 963-0329  
Fax: (714) 964-6236  
Email: [service@globalhobby.net](mailto:service@globalhobby.net)

### In Europe:

**Ripmax Ltd.**  
241 Green Street  
Enfield, EN3 7SJ, U.K.

Phone: (0) 20 8282 7500  
Fax: (0) 20 8282 7501  
Email: [xtm@ripmax.com](mailto:xtm@ripmax.com)

XTM Racing guarantees this kit to be free from defects in both material and workmanship, at the date of purchase. This does not cover any component parts damaged by use, misuse or modification. **In no case shall XTM Racing's liability exceed the original cost of the purchased kit.**

In that XTM Racing has no control over the final assembly or material used for final assembly, no liability shall be assumed for any damage resulting from the use, by the user, of the final user-assembled product. By the act of using the final user-assembled product, the user accepts all resulting liability.

## INTRODUCTION



The X-Crawler EP Super Class Crawler ARR is the new king of the Super Class crawlers! With machined aluminium gearboxes, steel suspension links with aluminium ball ends, and full ball bearing supported steel drive train, there's no obstacle that stands in the way of this beast! Able to articulate almost 90 degrees, the X-Crawler EP Super Class Crawler ARR can manoeuvre over the most difficult of courses with the help of its soft compound tyres which are mounted on machined aluminium bead lock wheels. Simply add your favourite electronics and get climbing!

Great care has been put into this Assembly Manual and Setup Guide to make it as easy as possible to assemble and set up your new X-Crawler EP Super Class Crawler ARR. Please read this Assembly Manual and Setup Guide in its entirety before starting assembly. This Assembly Manual and Setup Guide also includes a complete replacement parts list should you need to order replacement parts in the future, and detailed exploded view drawings for your convenience. You will also find good tips and recommendations throughout, so keep it handy for future reference.

## ROCK CRAWLING INFORMATION SOURCES



[www.rccrawler.com](http://www.rccrawler.com)

For your convenience, we've provided a few popular sources for all things Rock Crawling. Make sure to check out these websites for more information on rock crawling, including setup tips, current news, and more!

For even more information on rock crawling, we recommend searching online.



[www.ctrockcrawlers.com](http://www.ctrockcrawlers.com)

## RECOMMENDED ACCESSORIES

This section lists the recommended accessories that you need to purchase to finish your X-Crawler EP Super Class Crawler ARR, from this point on referred to as X-Crawler ARR. Listed first is our 'Standard Setup Recommendations', followed by our 'Pro Setup Recommendations'. Please read through the Accessory Setup Recommendations below first for more information about both setup recommendations.

**IMPORTANT:** Although the two different Setup Recommendations contain some specific brand names, you can use accessories of a different brand as long as they are equivalent to what's recommended.

### ACCESSORY SETUP RECOMMENDATIONS

The Standard Setup Recommendations will work well for those who are not hardcore into rock crawling and don't require the mixing capabilities provided by a high-end, twin-stick radio control system. The Standard Setup will provide good overall performance and work well for rock crawling. It is good for those who may already have a 2-channel radio control system and a standard 6 cell, 7.2V battery pack and charger. Using high-torque, metal-gear servos (minimum 10.0kg/cm @ 6V/140oz/in @ 6V) will ensure solid steering control and brushed 55 turn Crawler motors and ESCs are affordable and will give you good performance. Using a Y-Harness with an electronic reverser to join the two steering servos will allow 4-wheel steering. A standard Y-Harness will also be required to join the two ESCs. Depending on your chosen servo's lead length, you may also require extension leads to connect them to the receiver.







The Pro Setup Recommendations are for those who are looking for the ultimate rock crawler. To take full advantage of the dual motors and ESCs and the dual steering setup, a high end twin-stick radio control system that features enhanced mixing capabilities should be used. This will allow for a number of different steering and throttle mixing options that the hardcore rock crawler is looking for. Using higher torque metal-gear servos (minimum 14.4kg/cm @ 6V/200oz/in @ 6V) will provide the ultimate in steering control and power. Brushless sensed motors and matching ESCs provide the ultimate in smooth, low end torque. A LiPo battery pack can be used, or you can use a high-capacity 6 cell battery pack for added weight. Mounting the battery pack over the front axle, or even splitting the battery pack in two and mounting each half over both axles can be done to optimise weight and traction.

Regardless of the setup chosen, the ESCs should feature a 6V BEC to ensure the most torque to the steering servos. A Y-Harness battery connector will also be needed to join the two ESCs to the battery pack.

### STANDARD SETUP RECOMMENDATIONS

			
<b>2 or More Channel Radio Control System</b>	<b>2 x High-Torque, Metal-Gear Standard Size Servos</b>	<b>2 x 540 Size 55T Crawler Electric Motors with Matching ESCs</b>	<b>6 Cell, 7.2 Volt 3000mAh or More Battery Pack</b>
			
	<b>Servo Y-Harness</b>	<b>Servo Y-Harness with Reverser</b>	<b>NiCD/NiMH Peak Charger</b>
			
		<b>Battery Y-Harness</b>	

### PRO SETUP RECOMMENDATIONS

			
<b>4-Channel or More, Twin-Stick Radio Control System (Must operate on legal ground-based frequency)</b>	<b>2 x Digital High-Torque, Metal-Gear Standard Size Servos</b>	<b>2 x Brushless Crawler Electric Motors with Matching ESCs</b>	<b>NiCD/NiMH/LiPo Charger</b>
			
	<b>2 x 152mm/6" Servo Extension Lead</b>	<b>Battery Y-Harness</b>	<b>2 Cell, 7.4 Volt 4500mAh LiPo Battery</b>

## RECOMMENDED TOOLS AND SUPPLIES

In addition to the items listed on the previous page, the following tools and supplies will also be required to run and maintain your X-Crawler EP Super Class Crawler ARR:

- 8-Pack 'AA' Alkaline Batteries for Transmitter\*
- # 2 Phillips Head Screwdriver
- 1.5mm, 2mm, 2.5mm and 3mm Hex Wrenches
- 5.5mm and 7mm Nut Drivers
- Adjustable Wrench
- Hobby Knife
- Body Reamer
- Lexan Scissors
- Metric Ruler
- Threadlock
- Assorted Weights of Silicone Oil to Tune the Shocks (Optional)
- Soldering Iron and Solder
- Assorted Sizes of Heatshrink Tubing
- Nylon Cable Ties (Small) and Velcro®
- Assorted Paint and Materials to Finish Clear Body



\*Only required if your transmitter does not already include a rechargeable NiCD or NiMH battery.

## PARTS IDENTIFICATION

Before beginning assembly, use the parts list below to verify that your kit contains all of the correct parts. If your kit is missing any parts, please contact your local distributor, using the Customer Service Information on page 3.

### CHASSIS ASSEMBLY AND MISCELLANEOUS PARTS

- (x1) Centre Chassis Assembly
- (x2) Outer Chassis Assembly
- (x1) Clear Lexan Body Shell
- (x1) Antenna Support Tube with Cap
- (x1) Decal Sheet

### CHASSIS FASTENERS

- (x2) M3 x 40mm Cap Screw
- (x4) M3 x 22mm Cap Screw
- (x6) M3 Lock Nut
- (x14) M3 Tapered Collet

### BODY MOUNTS AND FASTENERS

- (x4) Body Post
- (x4) Body Clip
- (x4) M3 x 8mm Cap Screw

### SERVO MOUNTS AND STEERING LINKAGE FASTENERS

- (x2) M3 x 18mm Cap Screw
- (x8) M3 x 8mm Cap Screw
- (x2) M3 Tapered Collet
- (x8) M3 Flat Washer

### PINION GEARS AND MOTOR FASTENERS

- (x2) Pinion Gear (8T)
- (x2) M3 x 8mm Cap Screw
- (x2) M3 x 6mm F/H Machine Screw
- (x2) M3 x 3mm Grub Screw

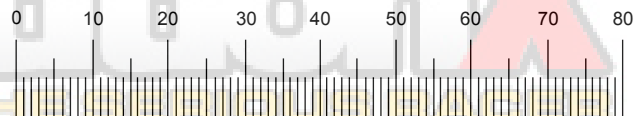

Use This Metric Ruler to Help You Determine the Size of the Different Fasteners.

## BECOMING FAMILIAR WITH YOUR X-CRAWLER EP SUPER CLASS CRAWLER ARR

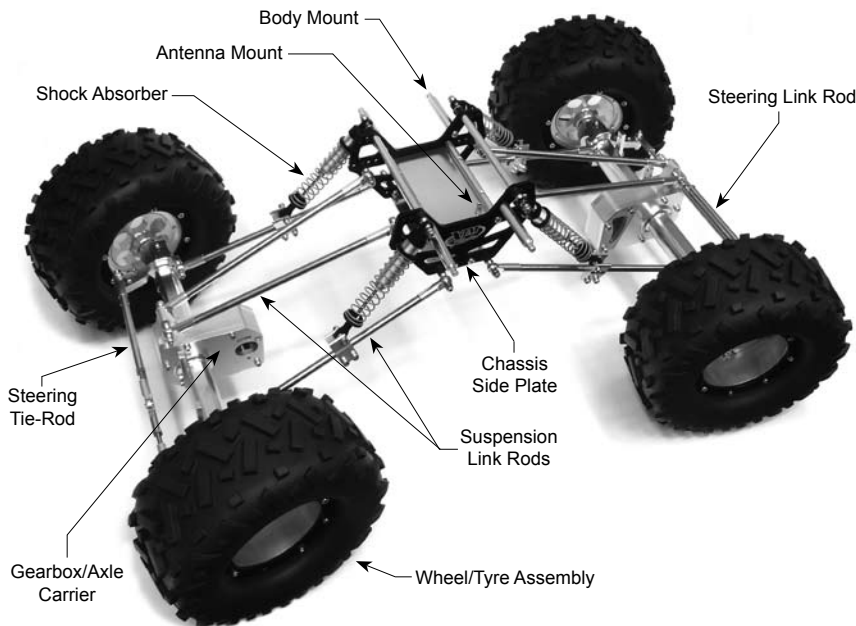

**Antenna Mount:** Holds the antenna support tube that your receiver antenna is fitted into.

**Body Mount:** Machined from aluminium for strength, the body mount supports the body. The X-Crawler ARR features four body mounts for maximum support.

**Chassis Side Plate:** Secures the suspension link rods and the upper and lower chassis plates to form the core of the chassis.

**Gearbox/Axle Carrier:** Made from high-strength, machined aluminium, the X-Crawler ARR features solid drive shafts and steel gears which are perfect for rock crawling. The axle carriers are machined from aluminium for strength and feature ball bearings to support the drive shafts and axles.

**Shock Absorber:** Each shock is oil-filled and uses a spring that is well suited for most rock climbing conditions. The shocks feature threaded shock bodies that allow the shocks to be easily tuned

for different conditions. The shocks come standard with # 200 (20 weight) oil and blue springs.

**Steering Link Rod:** Connects the two steering knuckles together, either end. The steering link rod is adjustable so you can make toe-angle adjustments to the front and rear wheels.

**Steering Tie-Rod:** The tie-rod connects the steering linkage and the steering knuckles, either end. The tie-rods are adjustable so you can make toe-angle adjustments to the front and rear wheels.

**Suspension Link Rods:** Connects the centre chassis assembly to the outer chassis assemblies/gearboxes. The suspension link rods allow the chassis to articulate almost 90 degrees.

**Wheel/Tyre Assembly:** The X-Crawler ARR features moulded rubber tyres with a tread pattern that is good for most rock crawling courses. The wheels are machined aluminium bead lock type which are extremely strong and make it easy to change tyres for different course conditions.

## ASSEMBLY TIPS FROM THE PROS

- Make sure to read this Assembly Manual and Setup Guide in its entirety before starting assembly. This will allow you to become familiar with the assembly process and ultimately make assembly quicker and easier.
- When we refer to right and left sides, we are referring to the driver's point of view, as if you were sitting inside the X-Crawler ARR.
- To prevent stripping the hex head screws, make sure to use a good-quality hex wrench of the correct size.
- When installing the pinion gears onto the motors, make sure that you tighten the grub screws against the flat spots on the motor output shafts. This will prevent the pinion gears from spinning during use. If the motors do not have a flat spot on their output shafts, cut a flat spot into them using a small file or grinding disc.
- Tighten all fasteners securely and apply threadlock to any screws that thread into metal. This will ensure that the screws do not loosen from vibration during use.
- When using threadlock, make sure to allow it to cure overnight before use. It's also important that both parts you apply threadlock to are clean, dry and free of any grease or oil.
- If you have difficulty sliding the antenna wire through the antenna support tube, first pull the antenna wire through your fingers several times to straighten it, then lightly wet the antenna wire with glass cleaner. The glass cleaner will make the antenna wire slide through the antenna support tube much easier.
- When you're installing the tapered collets when joining the chassis assemblies, note the direction that the tapered collets are installed. The narrow side of each tapered collet should be toward the inside of the ball links, otherwise the chassis will not articulate fully and will bind.
- When installing your steering servos and motors, make sure to leave a little bit of slack in the wires so that when the suspension articulates it won't pull, or otherwise damage, the wires.

## FINAL ASSEMBLY

The X-Crawler ARR comes from the factory partially assembled. Final Assembly should not take too long. Here is the list of procedures that must be done to finish your X-Crawler ARR:

- Join the two outer chassis assemblies to the centre chassis assembly, then install the body mounts.
- Install your electronics - servos, motors, electronic speed controllers (ESCs), and battery pack.
- Prepare and paint the body shell in the colour(s) of your choice, then apply the decals.
- Fit the body shell and set up the chassis to your desired specifications.

### STEP 1: JOINING THE OUTER CHASSIS ASSEMBLIES TO THE CENTRE CHASSIS ASSEMBLY

**1** - Remove the wheels from both outer chassis assemblies. Set the wheels and the wheel nuts aside for now.

**IMPORTANT:** Removing the wheels will make it easier to join the chassis assemblies and to install the steering servos and motors.

**PRO TIP:** Thread the wheel nuts back onto the axles to prevent the hex hubs from falling off during assembly.

**IMPORTANT:** Both ends of the centre chassis assembly are the same and both outer chassis assemblies are the same. There is no front or rear. The gearbox cases on the outer chassis assemblies should point toward the centre of the chassis (see below).

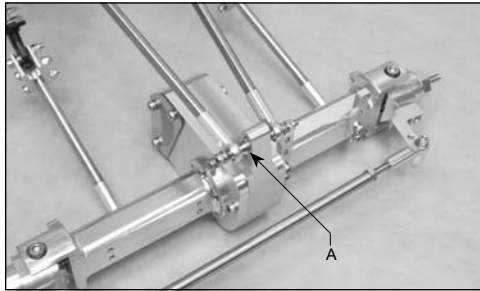

**2** - Connect the two centre link rods from one end of the centre chassis assembly to the **middle hole (A)** in one outer chassis assembly link rod mount, using one M3 x 40mm cap screw, four M3 tapered collets and one M3 lock nut.

**IMPORTANT:** Note the direction that the tapered collets are installed. The narrow side of each tapered collet should be toward the inside of the ball links, otherwise the chassis will not articulate fully and will bind.

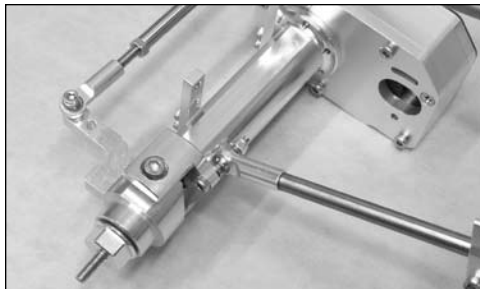

**3** - Connect one outer link rod from the centre chassis assembly to the outer link rod mount on the same outer chassis assembly, using one M3 x 22mm cap screw, two M3 tapered collets and one M3 lock nut.

**IMPORTANT:** Again, the narrow side of each tapered collet should be toward the inside of the ball links, otherwise the chassis will not articulate fully and will bind.

**PRO TIP:** Use an adjustable wrench to hold the lock nut in place while you tighten the lock nut.

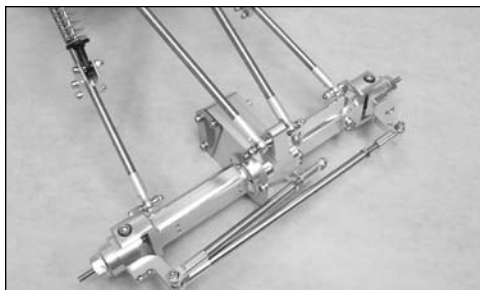

**4** - Use the same techniques as you did in step 3 above to connect the second outer link rod from the centre chassis assembly to the outer link rod mount on the outer chassis assembly (see image at left).

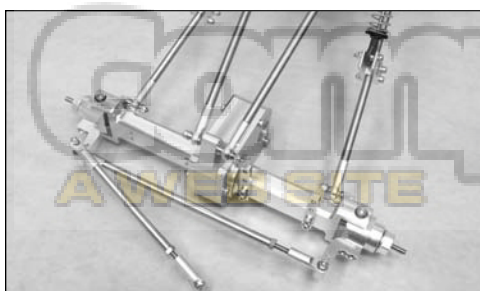

**5** - Repeat procedures 2~4 to install the second outer chassis assembly to the the centre chassis assembly.

**IMPORTANT:** Install the two centre link rods to the middle hole in the outer chassis link rod mount and make sure that the narrow side of each tapered collet is toward the inside of the ball links, otherwise the chassis will not articulate fully and will bind.



## STEP 2: INSTALLING THE BODY MOUNTING POSTS

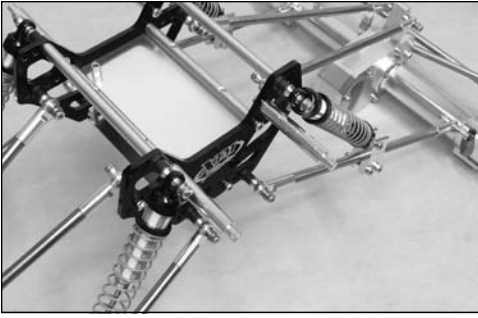

- 1 - Install each of the four body mounting posts into the uppermost holes (next to the shock towers) in the chassis side plates, using four M3 x 22mm cap screws.

**IMPORTANT:** Since the cap screws thread into metal, remember to apply threadlock to the cap screws to prevent them from loosening during use.

## STEP 3: INSTALLING THE STEERING SERVOS AND LINKAGES

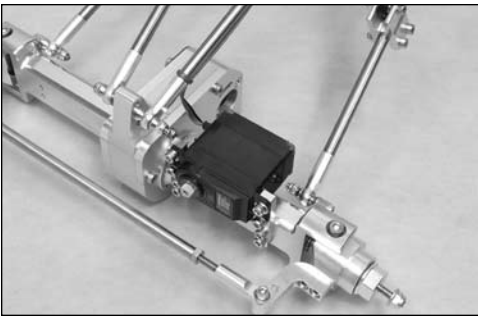

- 1 - Secure one steering servo to one servo mount, using four M3 x 8mm cap screws and four M3 flat washers.

**IMPORTANT:** Install the servo so that the servo output shaft is toward the gearbox.

**IMPORTANT:** Remember to apply threadlock to the cap screws to prevent them from loosening during use.

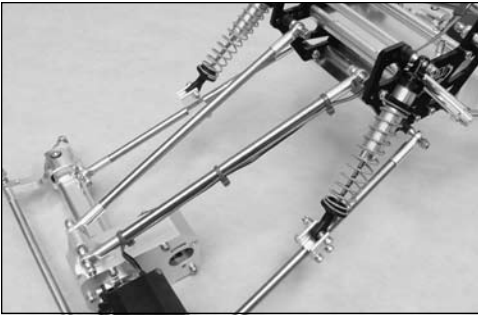

- 2 - Run the servo wire up the centre link rod and to the top of the chassis. Use two or three small nylon cable ties to secure the servo wire to the centre link rod as shown.

**IMPORTANT:** Leave a little bit of slack in the servo wire between the servo and the centre link rod, so that when the suspension articulates, it doesn't pull on, or otherwise damage, the servo wire.

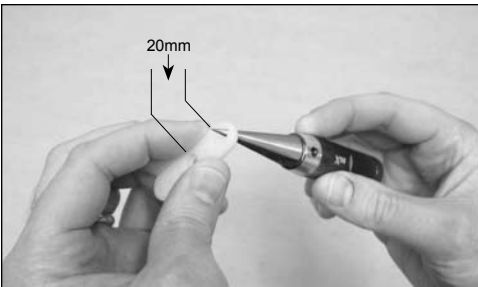

- 3 - Enlarge one hole in the servo arm 20mm out from centre to accept the M3 x 18mm cap screw that will be used to secure the steering link rod. You can do this with a body reamer or appropriately sized drill bit.

**IMPORTANT:** In the next step, you will need to temporarily connect the radio control system and plug the steering servo into the receiver. Be certain that you are familiar with the setup and function of the radio control system before continuing. If you have any concerns about setting up the radio control system, please refer to the radio control system's user guide.

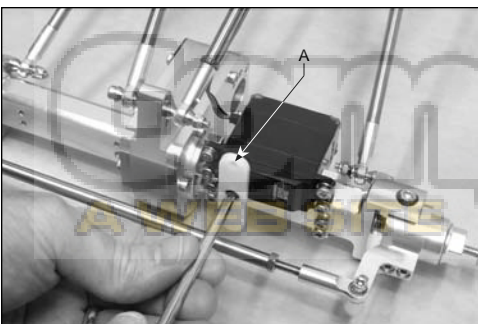

- 4 - Connect the radio control system and plug the steering servo into the receiver. Centre the servo, then attach the servo arm to the servo, making sure that the servo arm is aligned 90 degrees up and down.

**IMPORTANT:** Install the servo horn so that the hole that you enlarged in the servo arm (A) is toward the top of the chassis.

**IMPORTANT:** Remember to install the servo horn retaining screw, included with the servo, to secure the servo arm in place.



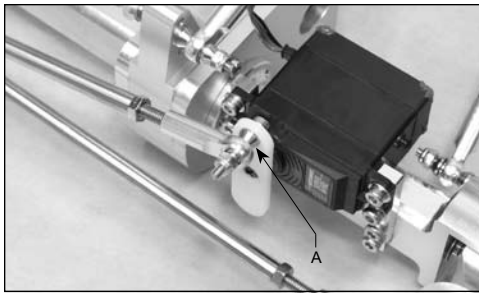

**5-** Connect the steering link rod to the servo arm, using one M3 x 18mm cap screw, one M3 tapered collet and one M3 lock nut as shown.

**IMPORTANT:** The cap screw is installed through the back of the servo arm and the tapered collet is installed against the front face of the servo arm (**A**). The narrow side of the tapered collet should be toward the inside of the ball link.

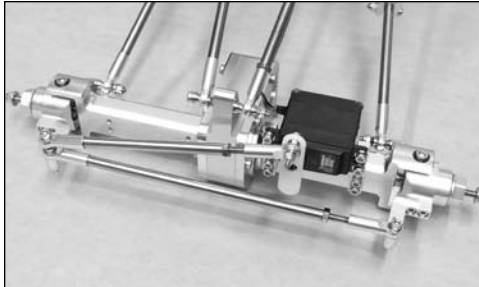

**6-** Repeat steps 1~5 to fit the second steering servo to the other servo mount and the steering linkage assembly. Once you're finished, unplug the radio control system and set it aside.

**IMPORTANT:** If the steering knuckles are not straight after you connect the steering link rods to the servo arms, don't worry about it now. We'll tell you how to adjust them correctly later in the chassis setup section.

#### STEP 4: INSTALLING THE MOTORS



**1-** Remove the three M3 x 8mm cap screws that hold the gear cover in place, then remove the gear cover and set it and the cap screws aside for now.

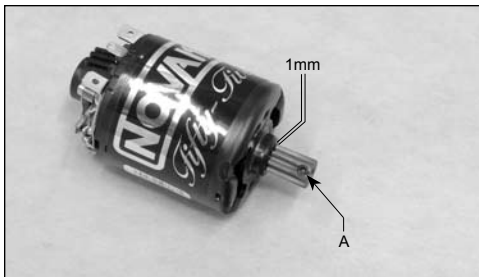

**2-** Fit one pinion gear onto one motor, making sure that there is no more than a 1mm gap between the end of the pinion gear and the motor (see left).

**IMPORTANT:** Install the pinion gear so that the grub screw is toward the **outside** of the motor (**A**). This will ensure that the pinion gear and the spur gear will mesh properly.

**IMPORTANT:** Tighten the grub screw against the flat spot on the motor shaft and apply locktite to the grub screw to prevent it from loosening during use.



**3-** Slide the motor into the gearbox and secure only the bottom of the motor into place for now, using one M3 x 8mm F/H machine screw.

**IMPORTANT:** Don't tighten the F/H machine screw completely. You want it slightly loose so that you can pivot the top of the motor back and forth to set the gear mesh.



**4-** Push the top of the motor forward so that the pinion gear meshes with the spur gear. The gear mesh should be set so that when the axle is turned, the movement should be smooth. If the movement is 'ratchety', the gear mesh is too tight. When satisfied with the alignment, install and tighten the M3 x 8mm cap screw into the top of the motor, then tighten the M3 x 8mm F/H machine screw from step 3 above.

**PRO TIP:** If you have a problem meshing the pinion gear with the spur gear, spin the axle slowly to turn the spur gear. While the spur gear is turning, push the top of the motor forward and the pinion gear will mesh with it.



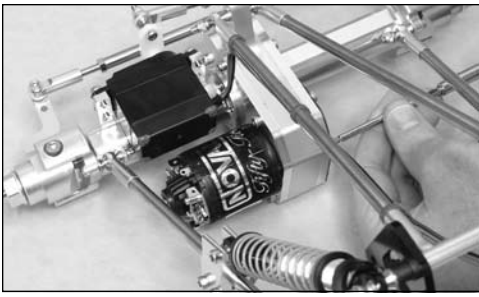

**5-** Refit the gear cover, then repeat steps 1~4 to install the second motor.

**IMPORTANT:** Do not overtighten the gear cover retaining screws or they may strip the threads in the gearbox.

**IMPORTANT:** Again, remember to apply threadlock to the cap screws to prevent them from loosening during use.

## STEP 5: INSTALLING THE ELECTRONIC SPEED CONTROLLERS (ESCS)

**IMPORTANT:** The installation locations of the two electronic speed controllers, the receiver and the battery shown in steps 5~7, is what we suggest if you're using the same accessories that we recommend. The electronics can be installed in a number of different configurations and may differ from what is shown due to their physical size or other factors. If you mount the electronics differently than what we show, there are a couple of things to keep in mind:

- Nothing can be mounted to the bottom of the lower chassis plate. Anything mounted to the bottom of the lower chassis plate will reduce the X-Crawler ARR's ground clearance and could interfere with its operation.
- The battery pack should be mounted as low as possible to keep the centre of gravity as low as possible. This will help make the X-Crawler ARR more stable.



**1-** Install the two electronic speed controllers (ESCs) to the top of the upper chassis plate, using double-sided tape as shown.

**IMPORTANT:** Depending on the length of the motor wires on the ESCs, you may need to solder new, longer motor wires in place to reach the motors.

**PRO TIP:** We suggest mounting each of the ESC ON/OFF switches to the inside of the two chassis side plates, using double-sided tape.

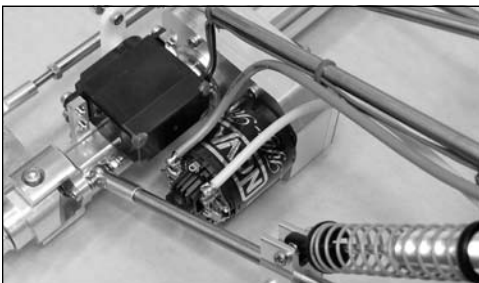

**2-** Solder the motor wires from one ESC to the motor on the same side of the chassis, making sure that the polarity is correct. Solder the positive (+) motor wire to the positive (+) motor terminal and the negative (-) motor wire to the negative (-) motor terminal.

**IMPORTANT:** Make sure that the motor wires are long enough so that there is enough slack in them to allow the suspension to articulate fully.

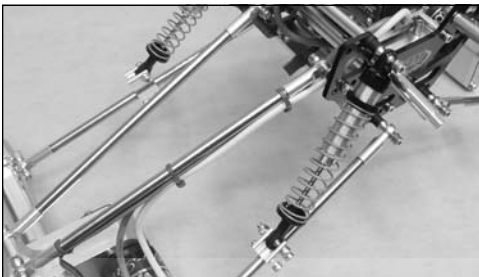

**3-** Use two or more nylon cable ties to secure the motor wires to the centre link rod.

**IMPORTANT:** Again, make sure that there is enough slack in the motor wires to allow the suspension to articulate fully.



**4-** Repeat steps 2~3 to solder the motor wires from the second ESC to the second motor, making sure to secure the motor wires to the centre link rod so that there is enough slack for the suspension to articulate fully.

## STEP 6: INSTALLING THE RECEIVER

**IMPORTANT:** The type of radio control system you use and how you prefer to set it up will determine how and where you plug the throttle and steering leads into the receiver. Based on our Standard and Pro setups, this is what we recommend:

- Standard (2 Channel or More, e.g. Airtronics/Sanwa MX-3, Futaba 3GR) - Connect the two steering servos using a Y-Harness with an electronic reverser and plug the Y-Harness into channel 1. Connect the two ESC throttle leads using a standard Y-Harness and plug the Y-Harness into channel 2.
- Pro (4 Channel or More Twin-Stick with Mixing, e.g., Airtronics/Sanwa RDS8000) - Plug the front steering servo into channel 2 and the rear steering servo into channel 4. Plug the front motor into channel 3 and the rear motor into channel 1.

The channel numbers that you plug the steering and throttle leads into will vary depending on the type of radio control system you're using and how you set up your X-Crawler ARR. For more information, please refer to the Chassis Setup Guide beginning on page 15.



- 1 - Fit the receiver to the inside of one chassis side plate, next to the receiver antenna mount, using double-sided tape. Plug the two ESC throttle leads and the steering servo leads into the receiver.

**IMPORTANT:** If you're using a 2.4GHz radio control system (like the Airtronics/Sanwa RDS8000), please refer to the radios' User Guide regarding receiver antenna placement to ensure trouble-free use.

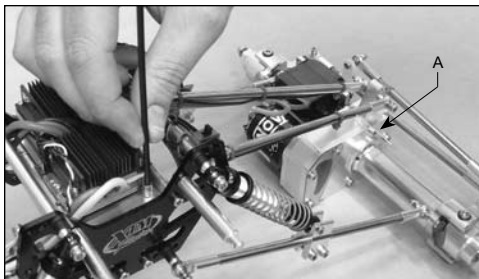

- 2 - Feed the receiver antenna up through the antenna mount in the upper chassis plate, then push the antenna support tube into the antenna mount.

**IMPORTANT:** If using a 2.4GHz radio control system that includes a receiver with two antennas, slide one antenna into the antenna support tube, then secure the second antenna to the centre link rod (**A**), using two small cable ties. Carefully bend the exposed tip of the antenna 90 degrees away from any metal to avoid a possible short-circuit.

**IMPORTANT:** If you're using a receiver that features a standard antenna wire (not 2.4GHz), **do not** cut the antenna wire shorter. Leave the excess antenna wire hanging from the top of the antenna support tube.

## STEP 7: INSTALLING THE BATTERY

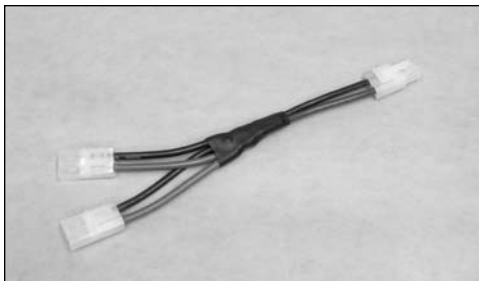

- 1 - Since the X-Crawler ARR uses two electronic speed controllers and a single battery pack, you must use a Y-Harness to join the two battery connectors from the ESCs to the connector on the battery. If you didn't buy a pre-made Y-Harness, you will need to make one using two female battery leads and one male battery lead. Simply solder the three positive (+) wires together and the three negative (-) wires together.

**IMPORTANT:** Make sure to use heatshrink tubing to insulate the solder joints and prevent any chance of a short-circuit.



- 2 - Mount the battery pack to the bottom of the upper chassis plate, using a piece of heavy-duty Velcro®. As an alternative, you could secure the battery pack into place using two large nylon cable ties or even double-sided tape.

**IMPORTANT:** If you use Velcro® to mount the battery pack, use heavy-duty Velcro® to ensure that the battery pack will be held in place securely.

**IMPORTANT:** When installed, the battery pack must be centred so that it doesn't interfere with the centre link rods.



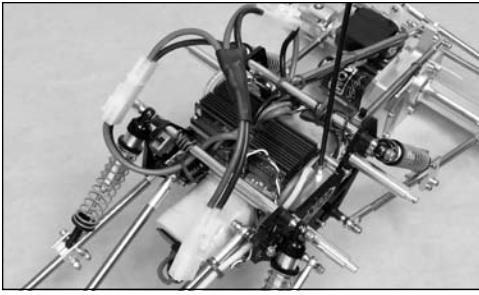

- 3- Double-check to make sure that both ESC ON/OFF switches are in the 'OFF' position, then plug the Y-Harness into the two ESC battery leads and plug the battery pack into the Y-Harness.

## STEP 8: FITTING THE BODY SHELL

**IMPORTANT:** The body shell can be mounted higher or lower than we recommend below. It's mostly personal preference, but keep in mind that if you mount the body shell too low, the wheels may hit it when the chassis is fully articulated.

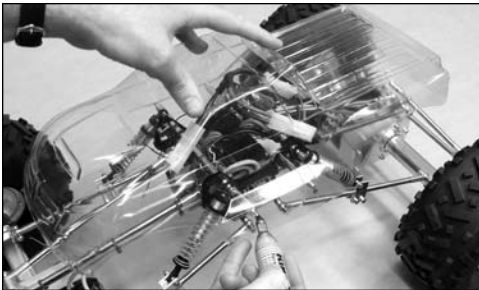

- 1- Once it's been cut out using your preferred method, place the body shell onto the chassis and align it, then mark the locations of the four holes for the body mounts, using a marker. We aligned the body so that the two body mounting posts on each side of the chassis were centred between the wheel wells and were 19mm / 3/4" up from the bottom edge of the body shell.



- 2- Remove the body shell and use a body reamer or drill to cut/drill the four 6mm diameter holes in the body shell at the marks you drew.

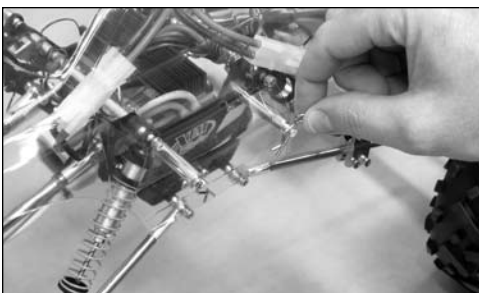

- 3- Fit the body shell onto the chassis to test the fit. Use the four body clips to hold the body shell in place.

**IMPORTANT:** Double-check that the body shell does not interfere with any part of the chassis or the suspension, particularly when the suspension is fully articulated. If it does, you'll need to trim the body shell slightly to fit around those areas.

- 4- Mark and cut/drill a 6mm diameter hole in the top of the body shell for the antenna support tube to pass through. Locate the hole directly above the antenna mount.

## STEP 9: PAINTING THE BODY SHELL

**IMPORTANT:** There is a protective plastic covering over the outside of the body shell. Do not remove it until after painting and before applying the decals. The plastic covering will protect the body from paint overspray.

- 1- Remove the body shell from the chassis and wash the inside of it with warm water and non-abrasive liquid detergent to remove any chemicals left over from the moulding process. Finish with warm water only. Completely dry the body shell using a soft cloth. After drying with a soft cloth, allow the body shell to air dry for a while.
- 2- Paint the inside of the body shell, using paint formulated for flexible body shells. **Do not paint the outside of the body shell.**
- 3- After the paint dries completely, peel back and remove the protective plastic covering from the outside of the body shell, then apply the decals. See pages 24/25 for recommendations on decal application.

## CHASSIS SETUP GUIDE

Chassis alignment and geometry are important if you want your X-Crawler ARR to perform well. A good performing truck means a truck that is easier to drive, too. Follow our guidelines in this section to get the most out of your X-Crawler ARR.

The guidelines that we provide in this section are a good starting point for most users, however, there are numerous different setting combinations that will give you different results. You should experiment with all of these settings to find what works best for your particular combination of course, driving style and truck performance.

**IMPORTANT:** It's very important when making changes to the settings of your X-Crawler ARR that you make the changes the same for each side. For example, if you change the spring tension on the right front shocks, you should change the spring tension on the left front shocks the same amount, etc.

### RDS8000 RADIO CONTROL SYSTEM SETUP

To get the most out of your X-Crawler ARR, we recommend using a twin-stick radio control system with high end mixing capabilities. For those who use the recommended Airtronics/Sanwa RDS8000 radio control system, we've provided some recommendations to help you get started. The RDS8000 transmitter settings below allow for 4 wheel or 2 wheel drive and offers 2 wheel or 4 wheel steering. The transmitter is set up in MODE 1. If you have the transmitter mixing set up with 4 wheel drive, then it's automatically set up for 4 wheel steering because it's on the same compensation mixing switch. There are a number of different ways to set up your transmitter, so experimentation will be necessary to find out what works best for you.

#### Initial Transmitter Setup

- Mode 1

#### Receiver/Servo Channel Setup

- Front Steering .....Channel 2
- Rear Steering.....Channel 4
- Front Motor .....Channel 3 with Red Wire Removed from Plug\*
- Rear Motor .....Channel 1

#### Transmitter Dual Rate, EPA, and Reverse Settings

- Elevator is set to 'REV'
- Elevator Dual Rate is set to '100%'
- Elevator EPA is set to '100%'
- Aileron is set to 'NOR'
- Aileron Dual Rate is set to '150%'
- Throttle is set to 'NOR'
- Throttle EPA is set to '100%'
- Rudder is set to 'REV'
- Rudder EPA is set to '150%'

#### Transmitter Miscellaneous Settings

- Under the ETC menu, make sure that the BASIC menu is Turned 'OFF'
- For C-MIX, set MAS to 'EL' and TH to 'SLV'
- E->T C-MIX is set to '100%', forward and reverse
- For the second C-MIX, set MAS to 'AI' and set RU to 'SLV'
- A->R C-MIX is set to '90%', left and right

Once the C-MIX is set, you can activate it using the 'AUX 1' switch. You'll notice that in small print it says 'C-MIX'. When the C-MIX is activated, both motors and both servos will work together. This way you will have 4WD with the left stick and 4WS with the right stick. You can still give independent controls of steering and throttle with the opposite sticks (i.e., even though you have mixing preset, you can give independent input to the rear motor on the right stick or give rear steering on the left stick as those are merely SLAVED channels and can operate independently until mixed). If you turn the mixing off, you have full control of each channel. This will allow you to dig the front end and have it come around or you can allow the X-Crawler ARR to crab, etc.

With the mixing off it's possible to make the X-Crawler ARR go sideways by giving opposite motor input with the 4WS. When you want to go back in the other direction, simply move the aileron and rudder sticks. It's possible to make the X-Crawler ARR spin on its own axis and more, just by giving different inputs.



\* We recommend removing the red wire from **one** ESC throttle lead so that the BEC input into the receiver won't be too high, as both ESCs are providing this to the receiver. Removing the red wire as indicated will ensure the receiver won't have too much voltage or amperage going to it.

## ADJUSTING THE TOE ANGLE

The toe angle is the angle of both front tyres (or rear tyres) to each other, when viewed from above. Toe-in is when the front of both tyres point toward each other and toe-out is when the front of both tyres point away from each other. Zero degrees of toe angle is when both front or rear tyres point straight ahead. For the most reliable handling, the toe angle should be set to zero degrees front and rear.

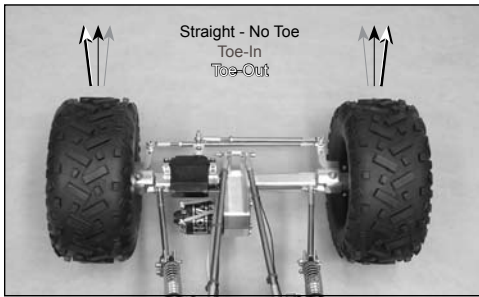

### RECOMMENDED INITIAL SETTINGS

- Zero degrees toe-in on both the front and the rear tyres.

**PRO TIP:** For more precise toe angle adjustments, use a dedicated toe angle adjustment gauge, available at most hobby retailers.

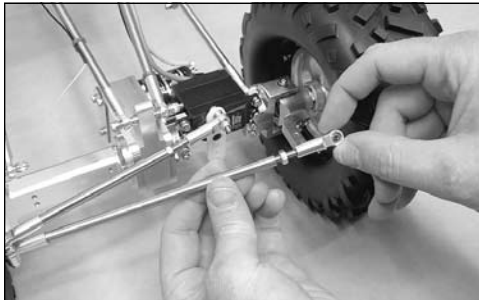

- 1** - With the steering servo arm centred, adjust the steering linkage rod until the the right-side tyre is pointing straight ahead (zero toe angle). To adjust the steering linkage rod, loosen the hex nut, then remove the ball link connected to the servo arm and adjust the length of the steering linkage rod by turning the ball link in or out. When satisfied with the alignment, refit the ball link and re-tighten the hex nut.
- 2** - Use the same technique that you did in step 1 above to adjust the tie rod until the left side tyre is pointing straight ahead (no toe angle). With the servo arm centred, both tyres should point straight ahead.

## ADJUSTING THE CHASSIS RIDE HEIGHT

The chassis ride height can be adjusted either higher or lower to suit different types of terrain. Ideally, the chassis should be high enough to clear the terrain, but not so high that the X-Crawler ARR becomes less stable.

### RECOMMENDED INITIAL SETTINGS

- We recommend leaving the chassis ride height in the factory stock position to start.

🔧 Move the lower shock holders up the link rod to raise the chassis ride height or down the link rod to lower the chassis ride height.



- 1** - To adjust the chassis ride height, first loosen the two lower shock holder retaining screws, then slide the shock holder up or down the link rod and retighten the retaining screws.

**IMPORTANT:** Make sure to adjust all four lower shock holders equally.

**IMPORTANT:** Be careful not to set the chassis ride height too low or you might high centre the X-Crawler ARR and/or scrape the terrain below.

## ADJUSTING THE CASTOR ANGLE

Both the front and the rear castor angle can be adjusted separately. While we don't recommend adding positive castor, negative castor may give you a little more side bite on the tire sidewall.

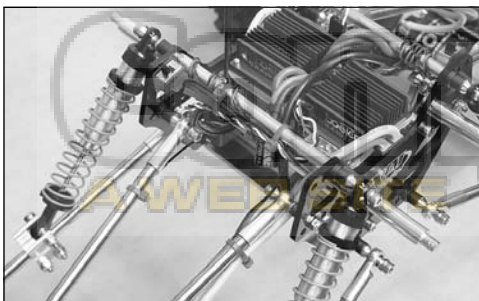

### RECOMMENDED INITIAL SETTINGS

- We recommend initially leaving the castor angle at the factory setting.
- 1** - Introduce negative castor by moving both inner link rods back one or more holes in the chassis side plates. This will pull the top of the gearbox assembly back, causing a negative castor angle.



## ADJUSTING THE SHOCK DAMPING

Changing the shock oil (the oil inside the shocks) will change the damping characteristics of the shocks. In general, using heavier shock oil may not allow the X-Crawler ARR to react as quickly to suspension changes and using lighter shock oil may make the X-Crawler ARR bounce a bit without absorbing bumps in the terrain.

### RECOMMENDED INITIAL SETTINGS

- We recommend using the stock shock oil that the shocks are already filled with.

 The shocks are filled with 20Wt silicone shock oil.



- 1- Remove the shock from the X-Crawler ARR, then carefully unscrew the shock cap.
- 2- Slowly pull the shock piston down completely, then empty the shock oil from the shock and wipe away any excess.
- 3- Fill the shock body with new shock oil until the oil level is just below the top of the shock body, then **gently** pump the shock piston up and down to dissipate any air bubbles from the shock oil. Top off the shock oil level if necessary, before reinstalling the shock cap.

**IMPORTANT:** Use 100% silicone shock oil. **Do Not use motor oil.**

## ADJUSTING THE SHOCK SPRING TENSION (PRELOAD)

The shock spring tension can be adjusted to fine-tune the chassis ride height and the damping quality of the suspension system. Threading each adjusting ring down increases spring tension and the chassis's ride height, and will stiffen the overall damping characteristics of the suspension. Threading each adjustment ring up decreases spring tension and makes the damping characteristics of the suspension softer.

### RECOMMENDED INITIAL SETTINGS

- We recommend initially leaving each adjustment ring in its factory location.



- 1- Increase or decrease spring tension by threading the adjustment ring up or down each shock body.

## ADJUSTING THE WHEELBASE

The wheelbase can be adjusted to suit the type of course or terrain you're driving on. The longer the wheelbase, the more stable the X-Crawler ARR will be, but the turning radius will be wider. In some cases you may want to shorten the wheelbase if you need a tighter turning radius because the course you're driving on is tighter.

### RECOMMENDED INITIAL SETTINGS

- We recommend initially leaving the wheelbase set at the factory length.

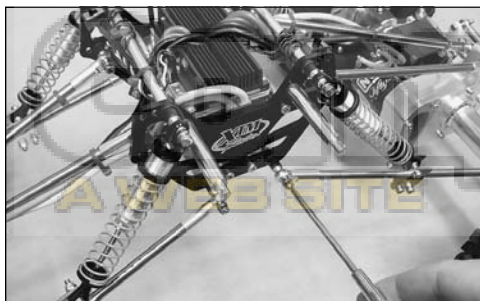

- 1- Increase or decrease the wheelbase by moving both outer and inner link rods in or out one hole in the chassis side plates. Moving the link rods toward the centre of the chassis side plates will shorten the wheelbase and moving the link rods toward the outside of the chassis side plates will lengthen the wheelbase.

**IMPORTANT:** If you change the wheelbase, you will need to readjust the lower shock holders so that the ride height doesn't change.



## TYRES AND FOAM INSERTS

The stock tyres and foam inserts included will work well for most users, however, you may want to experiment with different tyres and foam inserts, or even experiment with cutting the stock foam inserts. The X-Crawler is a Super Class crawler and uses 'Maxx' size wheels. When choosing different tyres, you should look for a tyre that suits your driving style and the terrain you're driving on. In general, you want the softest tyre available with an aggressive tread pattern. This type of tyre will provide the best traction in most situations.



Regarding the foam inserts, you want to use foam inserts that are just firm enough to support your X-Crawler ARR, but soft enough that the tyre can compress easily to ensure maximum traction. If the foam inserts are too stiff and don't allow your tyres to compress adequately, you can cut them. The most popular methods are to either cut the sides of the foam inserts to allow more sidewall flex or cut them into a star shape to allow easier compression of the tyre. In most cases, these techniques will provide a good combination of support and easy compression to ensure maximum traction.

## REPLACEMENT PARTS AND ASSEMBLY DRAWINGS

The Replacement Parts and Assembly Drawings contains two sections. The first section lists all of the replacement parts that are available for purchase. For your convenience, each replacement part is shown, along with the XTM Racing order number, a description, quantity amount per pack, and the corresponding step number that the replacement part is shown in to cross-reference the parts using the assembly drawings. The second section details the assembly of the X-Crawler ARR. Detailed illustrations in a step-by-step format make it easy to disassemble and reassemble the X-Crawler ARR. This is useful when it's necessary to replace worn/damaged parts or when it's time for a complete teardown for cleaning.

**When it comes time to order replacement parts, we recommend ordering directly from your local hobby retailer. If your hobby retailer does not stock XTM Racing products, contact your closest distributor for a local dealer, using the Customer Service Information on page 3.**

### REPLACEMENT PARTS (PAGES 16~17) ASSEMBLY MANUAL (PAGES 18~23)

XTM PART NUMBER	DESCRIPTION	PACK QTY	ASSEMBLY LOCATION
146820	Chassis Side Plate	2	Step 4
146821	Chassis Bottom Plate	1	Step 4
146822	Chassis Upper Plate	1	Step 4
146823	Chassis and Shock Support Rod	2	Step 5
146824	Side Plate Spacer Rod	2	Step 4
146825	Linkage Rod (No Ball End)	2	Step 5
146826	Ball End	2	Steps 3 and 5
146827	Ball for Shock End	4	Step 5
146828	Shock Mount	2	Step 5
146829	Linkage Rod with Ball End	1	Step 5
146830	Linkage Rod with Ball End and Shock Mount	1	Step 5
146831	Body Mount	2	Steps 4 and 6
146832	Body Clip	4	Step 6
146833	Shock Assembly - Complete	1	Step 5
146834	Shock Mounting Bushing	6	Step 5
146835	Antenna Holder	1	Step 4
146836	Tapered Collet (Triangle Washer)	4	Steps 3, 5 and 6
146837	Gearbox Housing	1	Step 1
146838	Gearbox Cover - Left	1	Step 1
146839	Gearbox Cover - Right	1	Step 1
146840	Spur Gear - 40T	1	Step 2



XTM PART NUMBER	DESCRIPTION	PACK QTY	ASSEMBLY LOCATION
146841	Inner Gear - 8T/34T	1	Step 2
146842	Motor Pinion Gear - 8T	1	Not Pictured
146843	Axle Tube Carrier - Left	1	Step 1
146844	Axle Tube Carrier - Right	1	Step 1
146845	Ball Bearing - 3x10x4mm (for Inner Gears)	4	Step 1
146846	Bushing 'A' - 3x4x5mm	2	Step 2
146847	Bushing 'B' - 3x4x1mm	2	Step 2
146848	Drive Shaft	1	Step 2
146849	Gear Pin - 3x23.5mm	2	Step 2
146850	Ball Bearing - 6x12x4mm (for Drive Shaft)	4	Steps 1 and 3
146851	Wheel Drive Axle	1	Step 3
146852	Pin - 2.5x11.5mm (for Drive Shafts (Middle) and Drive Axles)	4	Steps 2 and 3
146853	Servo Mount	2	Step 1
146854	Steering Knuckle	1	Step 3
146855	Steering Knuckle Arm	1	Step 3
146856	Steering Link Rod with Ball End	1	Step 3
146857	Steering Tie-Rod with Ball End	1	Step 3
146858	Adjustable Threaded Rod	2	Step 3
146859	Flanged Ball Bearing - 4x9x4mm	4	Step 3
146860	Fibre Washer (for Flanged Ball Bearings)	4	Step 3
146861	Clear Gear Cover	2	Step 2
146862	Hex Nut - 4mm	2	Step 3
146863	E-Ring - 5mm	8	Step 2
146864	Foam Tyre Insert	2	Step 3
146865	Tyre	2	Step 3
146866	Wheel Rim - Main	1	Step 3
146867	Wheel Bead Lock Ring	2	Step 3
146868	Wheel Hex Adapter	2	Step 3
146869	Wheel Centre Section	1	Step 3
146870	Shock Spring	2	Step 5
146871	Body Shell - Clear	1	Not Pictured
146872	Cap Screw - 3x8mm	10	Steps 1, 2, 3, 4 and 6
146873	Cap Screw - 3x18mm	10	Steps 3 and 5
146874	Cap Screw - 3x20mm	10	Step 5
146875	Cap Screw - 3x22mm	10	Step 6
146876	Cap Screw - 3x28mm	10	Steps 3 and 5
146877	Cap Screw - 3x45mm	4	Step 6
146878	Cap Screw - 4x10mm	10	Step 3
146879	Steering Tie-Rod (No Ball End)	1	Step 3
146880	Steering Link Rod (No Ball End)	1	Step 3
146881	Drive Shaft Pin (Outer) - 3x13mm	4	Step 2
146882	Wheel - Complete with Bead Locks (No Tyre)	1	Not Pictured
146883	Wheel - Complete with Bead Locks (No Tyre)	2	Not Pictured
146884	Flanged Lock Nut - 4mm	10	Step 3
146885	Antenna Support Tube	2	Not Pictured
146886	Grub Screw - 3x3mm (for Motor Pinion Gears)	10	Not Pictured
146887	Lock Nut - 3mm	10	Steps 3, 5 and 6
146888	F/H Machine Screw - 3x8mm	10	Steps 1 and 4
146890	Decal Set	1	Not Pictured
146891	Axle Assembly - Complete	1	Not Pictured



**STEP 1: AXLE CARRIER AND GEARBOX HOUSING ASSEMBLY**

**Finished Left Side**

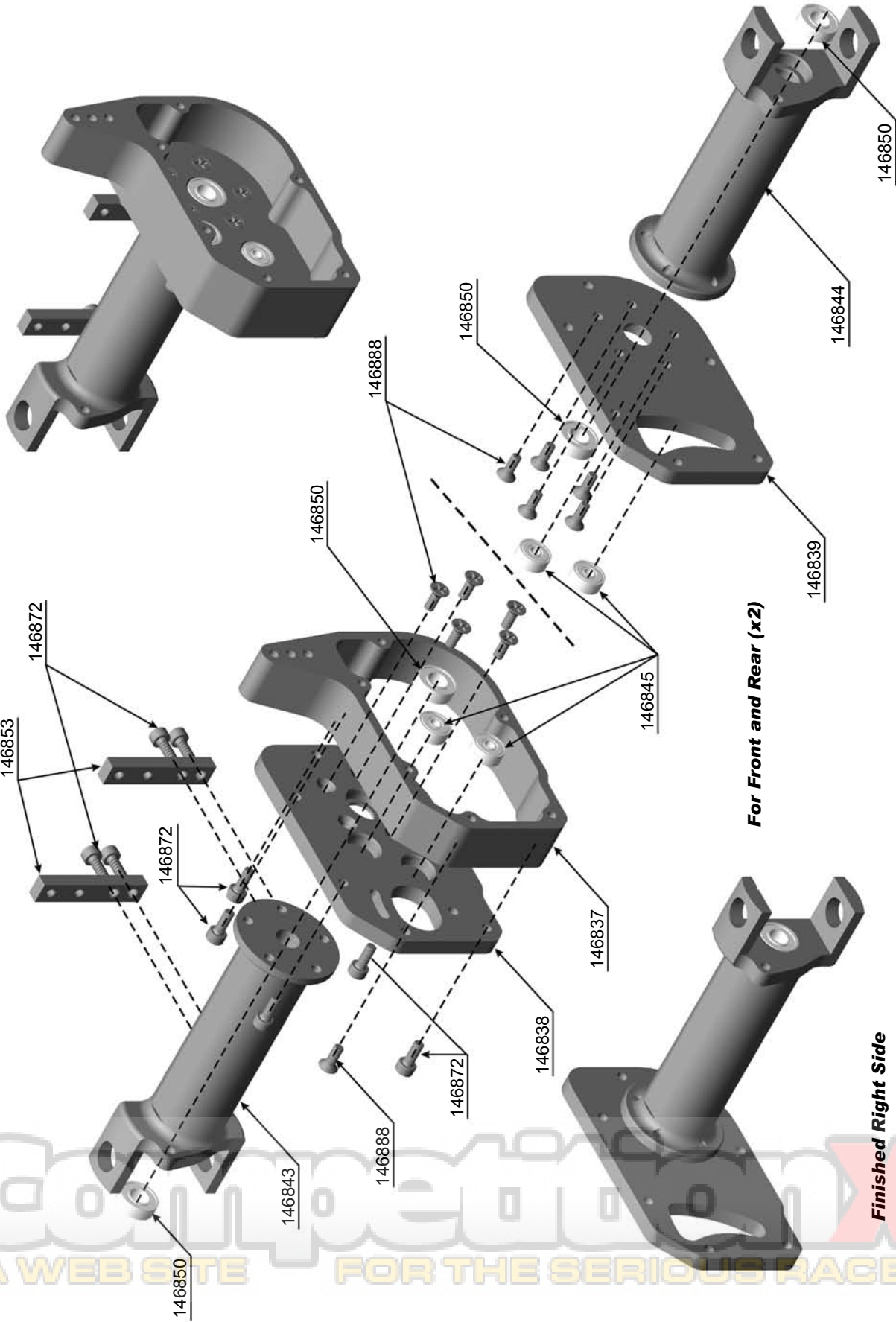

**Finished Right Side**

**For Front and Rear (x2)**

**GOLDSTAR**  
A WEB SITE FOR THE SERIOUS RAGER



**STEP 2: GEARBOX AND AXLE ASSEMBLY**

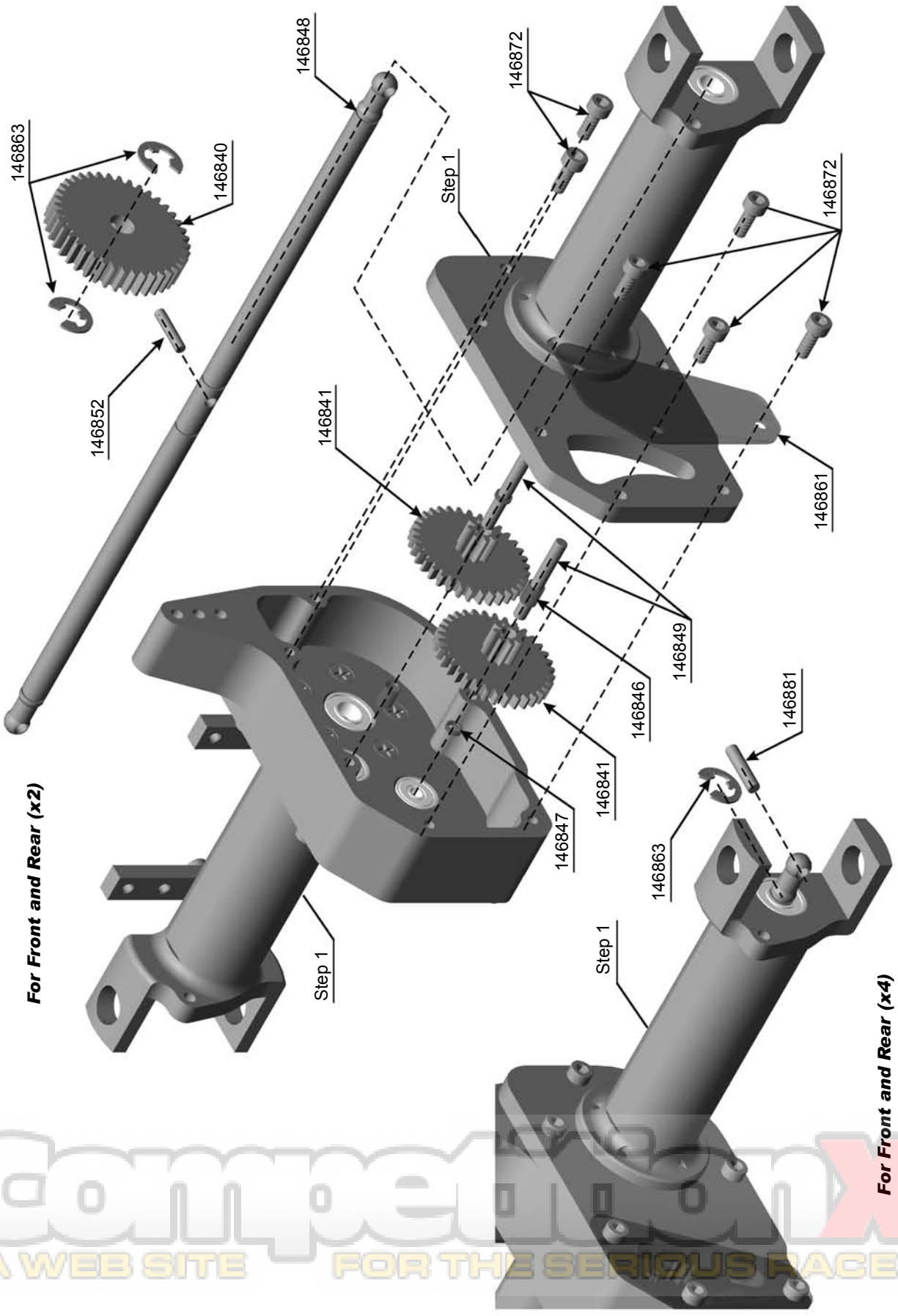

**STEP 3: WHEEL, AXLE AND STEERING LINKAGE ASSEMBLY**

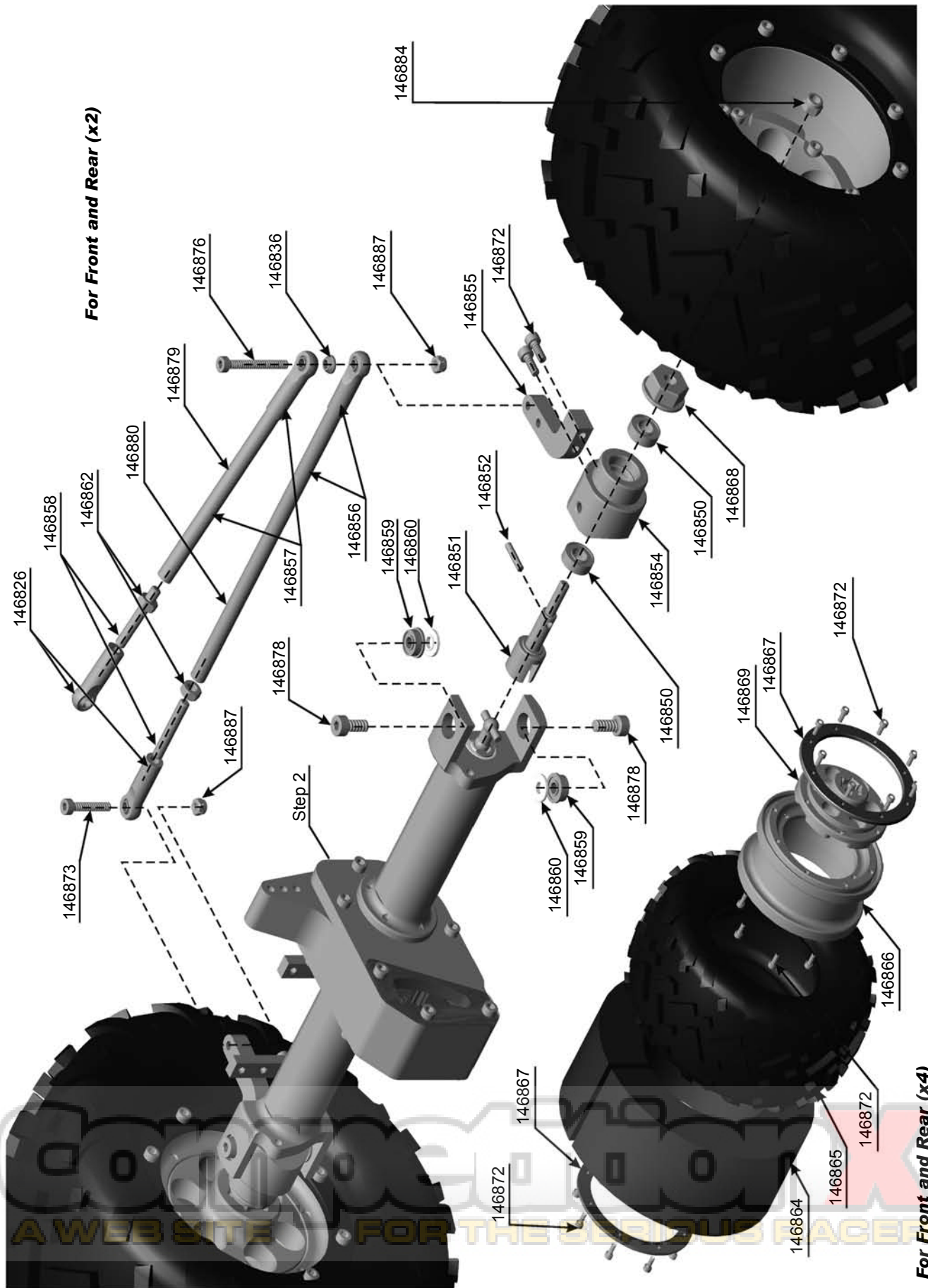

**STEP 4: CENTRE CHASSIS ASSEMBLY**

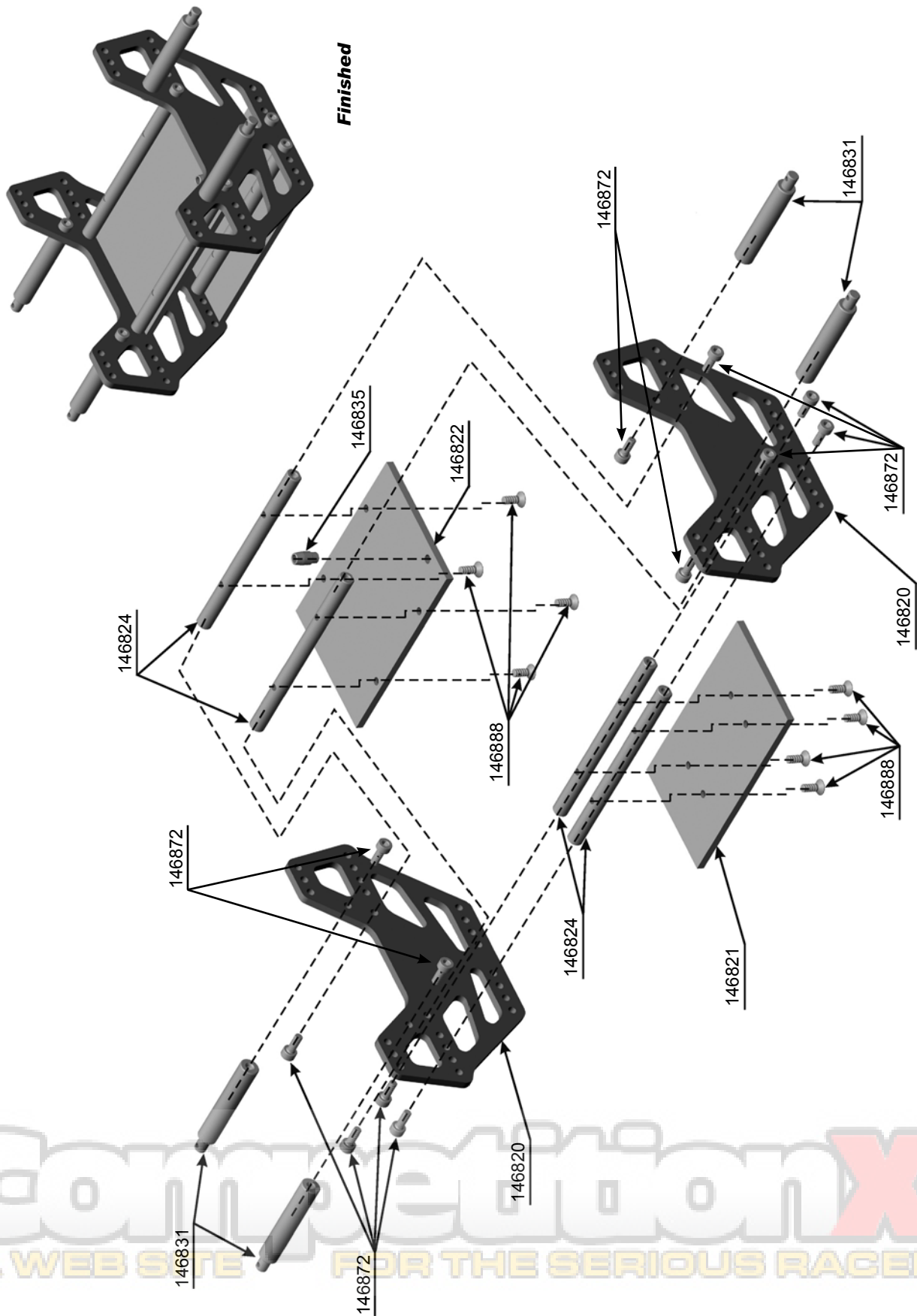

**CompetitionX**  
A WEB SITE FOR THE SERIOUS RACER





**STEP 6: FINAL CHASSIS ASSEMBLY**

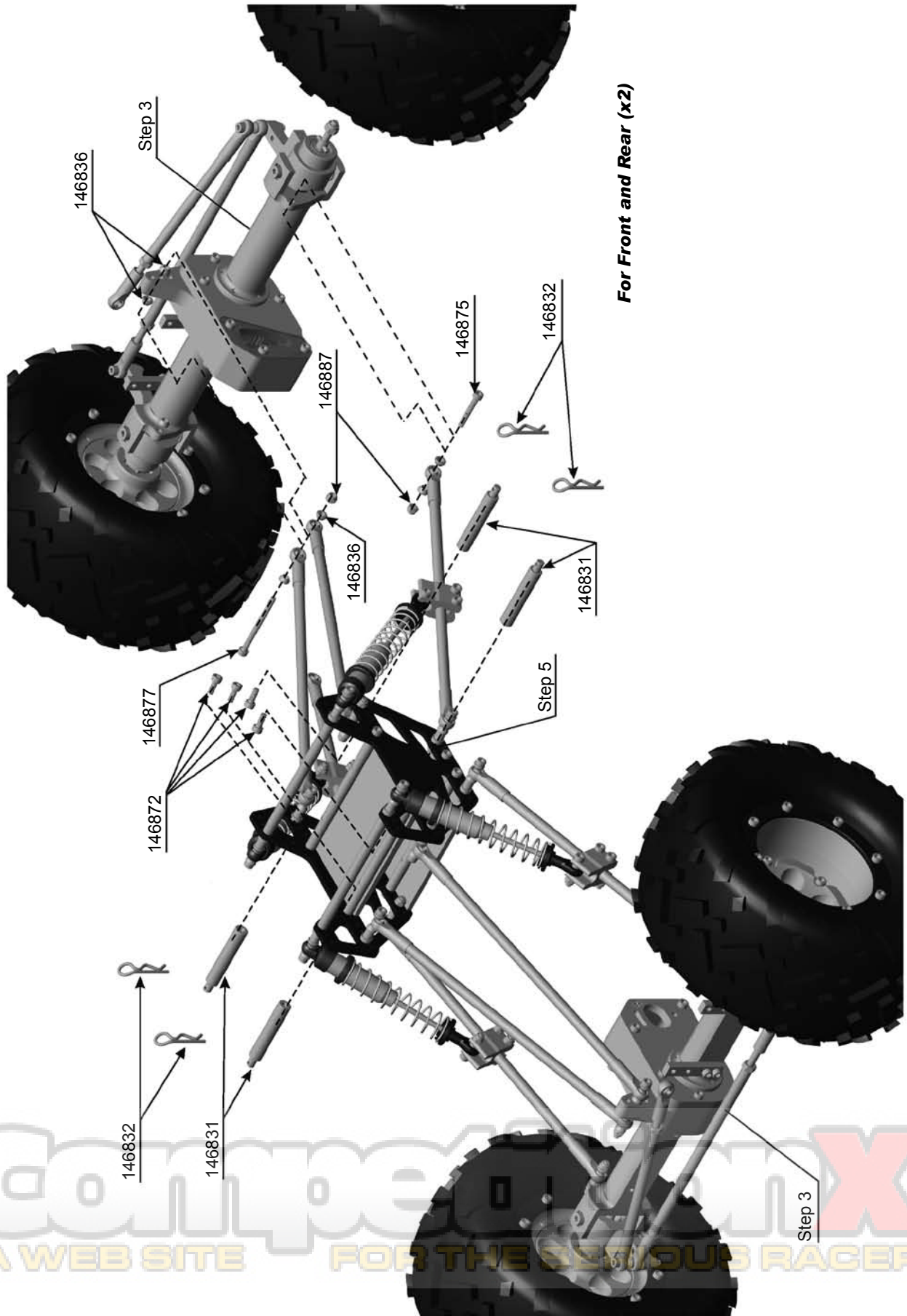

## APPLYING THE DECALS

The decals that are included in this kit are already die-cut from the factory. They are also known as 'peel and stick' so there is no need to cut them in order to remove them from the decal sheet. Most of them will be easy to apply, but those that go around a compound curve will need a little bit of assistance from you to apply neatly. Please be patient when applying the decals as this will result in a more professional appearance and finish.

For the next step, we'll assume that you have already painted your X-Crawler ARR body in the colour(s) of your choice, have let the paint dry completely and have removed the plastic film that protects the outside of the body shell. Before you begin applying the decals on the body we recommend that you clean the outside of the body with a mild soap (non-abrasive liquid detergent) and water solution. Do not use abrasives or abrasive cleaners as this will damage the body shell. Next, dry with a cotton towel (so that it does not scratch the body), and have the following tools ready to assist you with the decal application:

- X-Acto Knife (or similar)
- Heat Gun or Hair Dryer
- Window Cleaning Liquid (such as Windex®)
- Paper (Kitchen) Towel

Begin by placing the decals that go on the flat areas of the body first. These are straight forward to apply and do not need the suggested tools mentioned above, although it can sometimes be useful to use the knife to help you position some decals. This includes your preferred side windows, windshield and grill decals, as well as the hood scoop, rear roll bar/rear window display, website logos, 'XTM Racing' logos, and the smaller 'X-Crawler' decals, if those are chosen for the sides of the body shell. If you intend using the larger 'X-Crawler' decals for the sides of the body, we recommend you use the recommended tools as detailed above to apply them.

For the larger 'X-Crawler' decals, apply one at a time. Apply a small amount of window cleaning liquid to the side of the body shell in and around the door area, moving the liquid around with your finger until there is a very thin coat of it covering the area where the decal is to go. This is to allow the decal to be lifted up once if it is not placed in the correct location. However, be careful not to apply too much liquid on the body or the decal will not stick at all! If in doubt, practise first using some of the waste material left over from when you cut out the body shell and one of the larger decals that you don't intend using.

Place the 'X-Crawler' decal gently on the side of the body so that the 'X' section is about 8~10mm from the bottom edge of the window decal, and the 'Crawler' section is on the angled part of the door. Gently press on the 'X' part of the decal at the top and work your way down to the bottom of the 'X' until it is firmly placed. As you begin to press on the 'Crawler' portion of the decal, we suggest that you start from the centre and work your way to the outer part of the decal with a little assistance from a hair dryer or heat gun on its lower heat setting. Note that using too much heat will cause the decal to melt or become disfigured - in the worst cases it could also melt the body itself, so be very careful when doing this. Using the heat gun will help allow the decal to stretch a bit into the various angles of the body.

Next, apply a small amount of window cleaning liquid to the right side headlight area of the body shell and spread it around with your finger. Notice on the headlight decals that they are almost divided where the bottom 2/3 are the light section, and the top 1/3 is like a brow for the lights. Choose the headlight set you like the most from the three choices given. Place the bottom portion of the right side headlight decal to the appropriate area of the body shell, but only apply pressure to the bottom section of the decal. With the bottom of the decal in place, make a vertical cut in the upper part of the decal 2/3 of the way up from the front, near the turn indicator. Make sure that this cut is perpendicular to the edge of the decal. Next, apply a small amount of pressure to the upper 1/3 of the decal as this portion must be pressed down next. A slight amount of heat might assist in this process. Then, gently press the remaining front 2/3 of the decal down with the assistance of the heat gun so that it slightly overlaps the upper 1/3 portion that was previously applied, starting at the front edge and working back towards the turn indicator. Repeat the same process for the left side headlight.

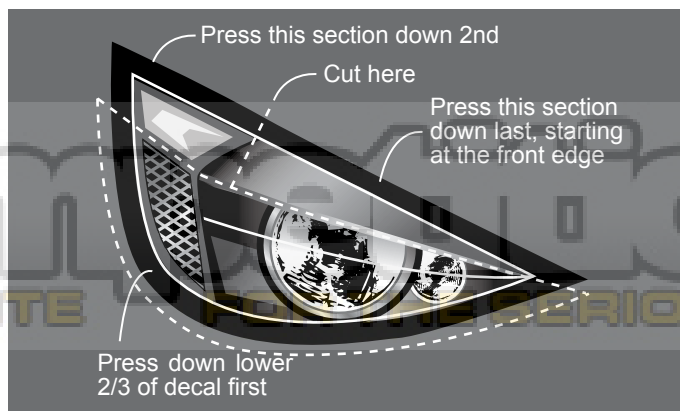

## APPLYING THE DECALS

The front bumper decal will require the most attention as it is the largest/longest decal and has to bend around a compound curve. Begin by placing a thin coat of window cleaning liquid on the front bumper area of the body. Once aligned, press down on the centre of the bumper decal, where the 'XTM Racing' logo is, so that you have one point that is firmly attached. Notice that the bumper decal is surrounded by a 4mm black border. On the top portion of the decal, make small vertical cuts in the black border about 10mm apart. This will help the decal 'wrap' around the curve. With the cuts made, apply a small amount of pressure to the middle and lower portion of the bumper decal. A slight amount of heat can be useful here. Once the bottom and middle portion of the decal is applied, begin by pressing the top portion of the decal down beginning in the centre (near the 'XTM Racing' logo) and working your way to the outer edges near the wheel arches. Only do one section at a time and use a heat gun to assist in bending the decal around the corners. The reason for doing one section at a time is so that the decal can overlap onto itself if it needs to in the areas where you made the vertical cuts. If any air bubbles have formed under the decal, apply a small amount of pressure with the knife to pierce the decal and release the air by pressing down on the affected area with your finger.

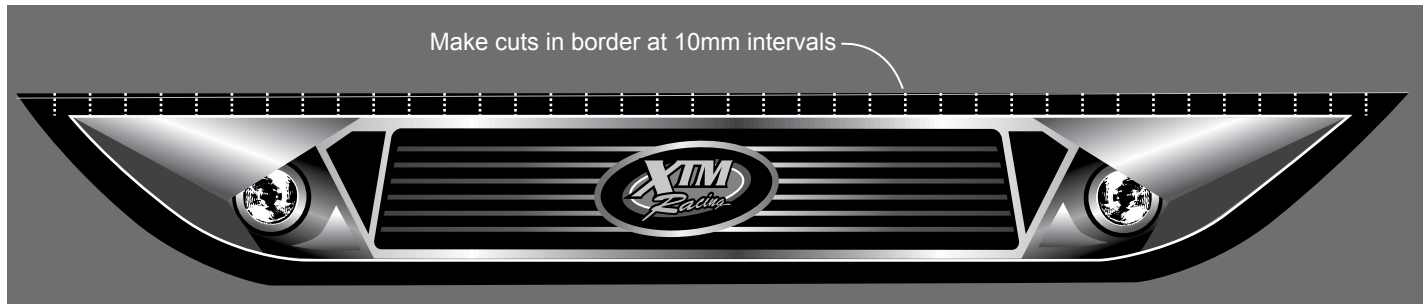

The 'Tail Light' decals are best cut prior to removing them from the decal sheet. Note that there are silver-coloured borders surrounding the red and yellow portions of each tail light, and a 3mm black border separating these two portions. Make a perpendicular cut from the top of each 'Tail Light' decal coming down 20mm through the 3mm black border, closest to the silver border of the yellow signal portions, so that there is still 5mm of black border joining each decal at the bottom. Carefully remove one of the tail light decals from the decal sheet being careful not to tear it as you do. Place the red tail light portion of the decal on the rear of the body in the appropriate area and press on it to fix it in place. Next, using the bottom 5mm of uncut decal as a pivot, move the top edge of the yellow signal portion of the decal towards the red section, overlapping the 3mm black border that separates the two sections as you do. Once the desired position is achieved, press the remainder of the decal down, starting from the bottom and working up to the top. The signal (yellow) portion of the decal should lay on top of the 3mm black border but should not overlap the red portion of the tail light.

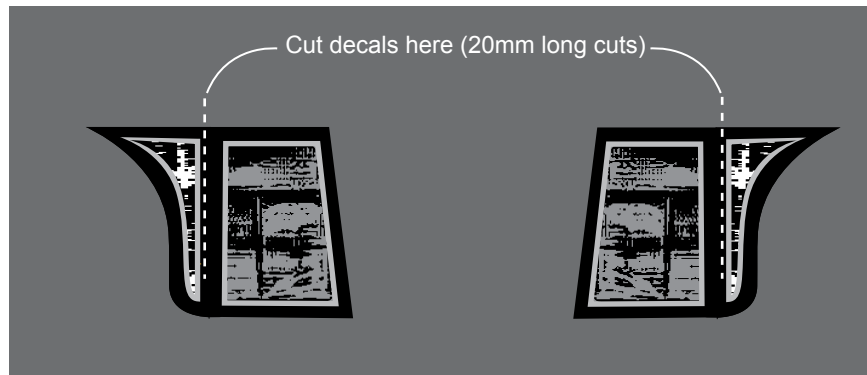

Once finished, you will have a professional looking rock crawling body that is the envy of all your friends!



## IMPORTANT WARRANTY SERVICE INFORMATION

Before returning your X-Crawler EP Super Class Crawler ARR for warranty consideration, the status of the unit must be within the Warranty Information as stated below. Do not return your X-Crawler EP Super Class Crawler ARR to the place of purchase. They are not authorised, nor equipped, to perform warranty work on XTM Racing products. When requesting warranty service, please observe the following:

- Crash damage will not be covered under warranty. Do not request warranty service for a crash-damaged product.
- This warranty covers the XTM Racing X-Crawler EP Super Class Crawler ARR only. It does not cover your separately purchased accessories, such as motors, electronic speed controllers, batteries, radio control system, etc. Please remove your accessories from the chassis before sending the product to us.
- Include a note detailing the problem or service you are requesting. Service cannot be provided without this information. Include your daytime phone number, shipping address and/or email address in the event we need more details pertaining to the service requested.
- If your vehicle is out of the warranty period you may request an estimate of services at the time you return your vehicle for service. An omission of this request implies permission for Global Services / Ripmax Ltd. to service your vehicle at our discretion.
- Include a method of payment for any service charges.
- Send the unit to us by United Parcel Service, Federal Express or by Insured Mail. Return postage is non-refundable. Send your package to:

### **In North America:**

**Global Services**  
**18480 Bandilier Circle**  
**Fountain Valley, CA 92708**



**Phone: (714) 963-0329**  
**Fax: (714) 964-6236**  
**Email: [service@globalhobby.net](mailto:service@globalhobby.net)**

### **In Europe:**

**Ripmax Ltd.**  
**241 Green Street**  
**Enfield, EN3 7SJ, U.K.**



**Phone: +44(0) 20 8282 7500**  
**Fax: +44(0) 20 8282 7501**  
**Email: [xtm@ripmax.com](mailto:xtm@ripmax.com)**



## WARRANTY INFORMATION

### **In North America**

Your XTM Racing X-Crawler EP Super Class Crawler ARR is warranted against manufacturer defects in materials and workmanship for a period of 90 days from the date of purchase. Warranty service will be provided within 90 days of the date of purchase only if you are able to provide the original or a copy of the original dated sales receipt.

### **In the United Kingdom/Europe**

Your XTM Racing X-Crawler EP Super Class Crawler ARR is warranted against manufacturer defects in materials and workmanship for a period of 1 (one) year from the date of purchase. Warranty service will be provided within one (1) year of the date of purchase only if you are able to provide the original or a copy of the original dated sales receipt. This does not affect your statutory rights.