

Mesh D17xx OEM Integration

V0.1  
24/04/2015

## Table of Contents

Table of Contents .....	2
Change History .....	3
Introduction.....	4
Hardware Overview .....	5
PCB Variants .....	7
Mechanical Design.....	8
Functional Specification .....	9
Connector Pin outs .....	11
J1 Aux Power Out .....	11
J2 Power Input .....	11
J3 RS485 Serial Data Port .....	11
J4 Power to D550 Encoder .....	11
J5 1W Amplifier Power and Enable.....	12
J6 RF Output.....	12
J7 RS232 Serial Control .....	12
J8 BDM/JTAG (Reserved).....	12
J9 RS232 to control D550 Encoder .....	12
J10 Talkback Audio connections.....	12
J11 Connections to D550 Encoder .....	13
J12 RS232 External Serial Data Ports .....	13
J13 RTC Battery connector .....	13
J14 External 10/100 Base-T Ethernet Port.....	13
J15 External Secondary 10/100 Base-T Ethernet Port .....	13
J16 USB connector (Not currently used) .....	14
J17 LED Drive .....	14
J18 Power over Ethernet .....	14
J19 Antenna B (Rx 1).....	14
J20 SD Card Management .....	14
J21 (not on board).....	15
J22 Antenna A (Tx Rx 0).....	15
J23 (not on board).....	15
J24 RF Out .....	15
Mounting Considerations .....	16
Heat sinking.....	16
Connector clearance .....	16
Turning On the System .....	17
1. Test Setup.....	17
2. Initial Setup .....	17
2.1 Setting unit type .....	17
2.2 Software updates.....	18
3. Verify the RF RX performance .....	18
4. Verify the RF TX performance.....	21
5. Spectrum Verification .....	22
6. Set RTC Clock .....	22
7. Ethernet Video Streaming.....	23
8. Recording and Playback.....	23
9. Direct connection to PC.....	24
10. Serial RS232 Control .....	24
RS232 Control – General Principles .....	24
Command Packet Structure .....	24
Reply Packet Structure .....	24
Control Commands.....	26

## Change History

<b>Version</b>	<b>Main Changes from Previous Version</b>	<b>Edited By</b>
<i>V0.1</i>	<i>First Draft</i>	<i>CM 24/05/15</i>

## Introduction

This document outlines the hardware integration for the D17XX IP Mesh baseband transceiver card.

The Cobham D17XX PCB is a digital diversity IP Mesh transceiver, designed specifically as the baseband and IP processing card for the Cobham IP Mesh phase 4 system. The system allows wireless IP, digital video and audio transmission in mobile, urban and non-line-of-sight scenarios.

Equipped with Ethernet and serial control interfaces, the D17XX is easy to integrate into a larger system.

The key design criteria for this solution were:

- Low power consumption
- Small size
- Ease of integration

Features include:

- 2.5MHz / 3MHz / 3.5MHz / 5MHz and 6MHz operating bandwidth modes
- Two-way diversity Maximum Ratio Combining for fade and multipath elimination
- Internal AES 128 / 256bit encryption (optional)
- Twin IP interfaces
- Multiple Serial interfaces
- SMP connectors for reduced size and ease of connection
- Optional Encoder offering very low delay video operation for real time applications
- Interfaces for optional 1W amplifier
- Talk-back Audio
- Micro SD card for 32GB storage
- Low power—typically **?W**

## Hardware Overview

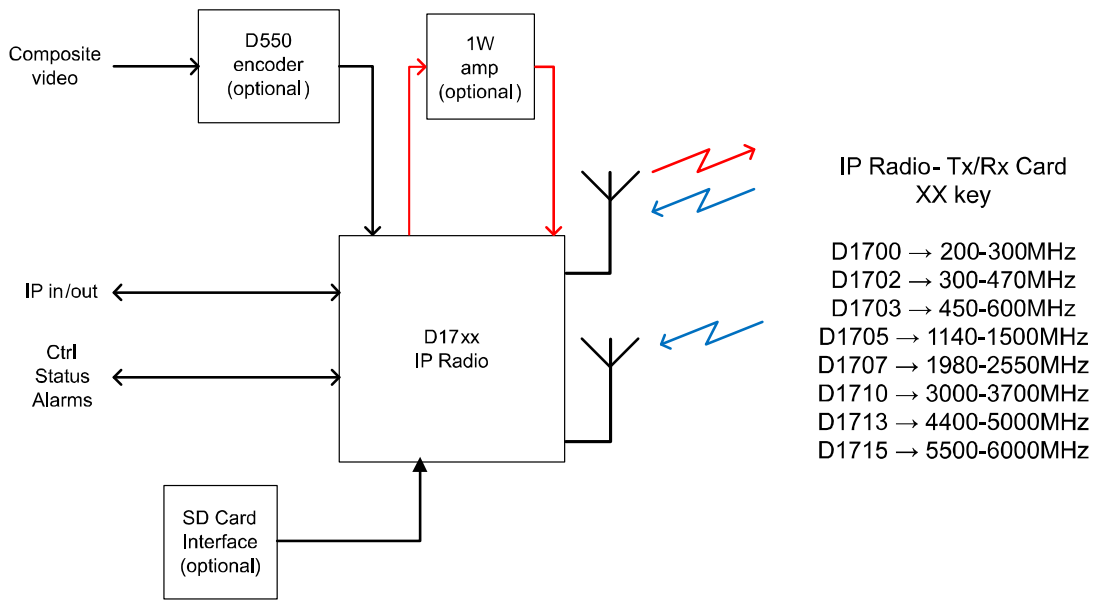

**Figure 1: D17XX overview block diagram**



**Figure 2: D1705 hardware overview**

Features of the D17XX board are:

- Kintex 7 FPGA and Coldfire microprocessor further reducing power consumption of the unit and increasing the processing power
- Large SDRAM and Flash
- Ethernet, RS485 and RS232 capability
- Recording to SD card (when optional encoder is fitted)
- Talkback Audio facility

## PCB Variants

The frequency selection is provided by the choice of RF card and setting the unit type on the D17XX.

Product No.	Frequency [MHz]
D1700	200 – 300
D1702	300 – 470
D1703	450 – 600
D1705	1140 – 1500
D1707	1980 – 2550
D1710	3000 – 3700
D1713	4400 – 5000
D1715	5500 – 6000

**Table 1: D17XX variants (without screen cans)**

A number of the boards are available in top-level assemblies.

Cobham SA Number	Description
SA3024	D1707 OEM AGILE IP MESH, Mk4 (S Band 1.98-2.55GHz) Top Level Assembly
SA3245	D1705 OEM AGILE IP MESH, Mk4 (L Band 1.14 - 1.5GHz) Top Level Assembly
SA3334	D1705_D DSTAR OEM Agile IP MESH, MK4 (L Band) Top Level Assembly
SA3453	D1703 OEM Agile IP MESH, MK4, 450-600MHz (UHF Band) Top Level Assembly
SA3457	D1741 OEM Pavement RF Board (S Band 1.98-2.55GHz) Top Level Assembly

**Table 2: Sub-assemblies featuring D17XX parts (with screen cans)**

**Mechanical Design**

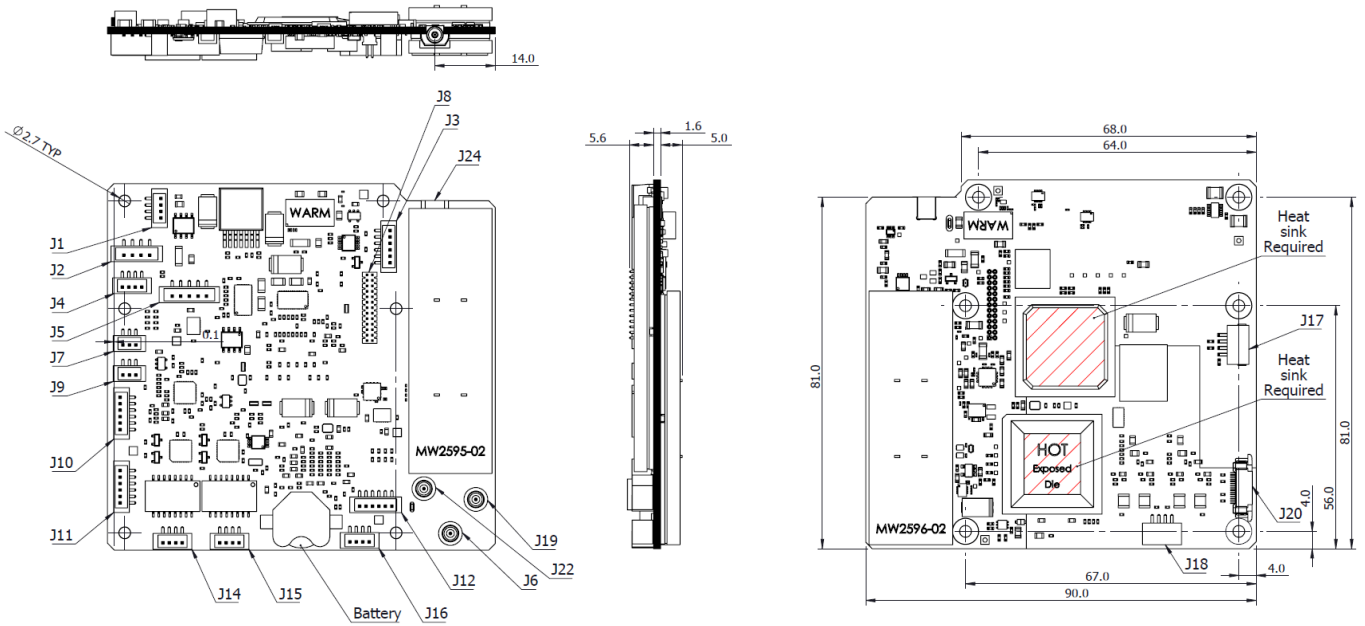

**Figure 3: D17XX connectors and heat sinks**

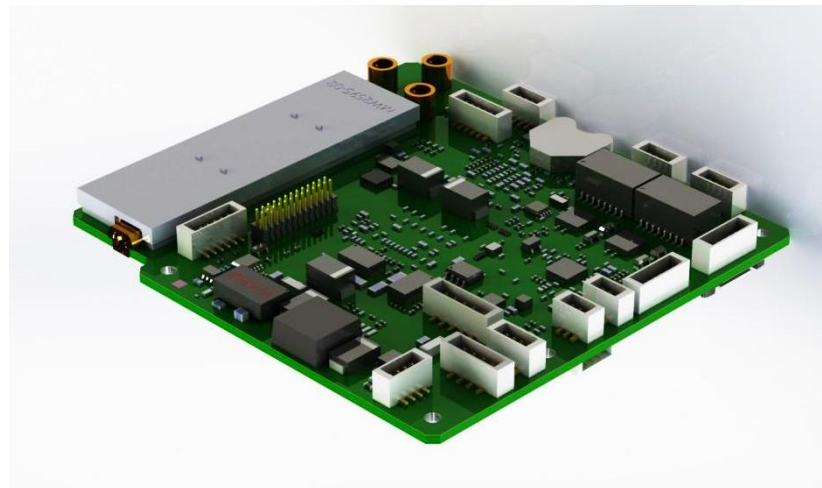

**Figure 4: D17XX isometric view**



## Functional Specification

### Interfaces

RF Interfaces (Antenna 1 and 2)	SMP
Power	JST J2
Ethernet 1	JST J14
Ethernet 2	JST J15
Control and misc. I/O	JST J3 (RS485) and JST J12 (RS232)
Camera (A/V)	Optional Card – D550

### Typical range

S-Band (1W)	Non-LoS light urban 500-700m LoS 40km+
-------------	---

### RF Interfaces

Antenna 1	Switched transmit (100mW) & receive antenna
Antenna 2	Receive only antenna
Tuning step size	125kHz step
Output power	+20 to -10dBm in 0.25dB steps (100mW variant) +30 to 0dBm in 0.25dB steps (1W variant)
Bandwidth	2.5, 3.0, 3.5, 5.0, 6.0MHz
Mesh capacity	Up to 8 Mb/s
Modulation	COFDM 360 carrier modulation
Carrier Modulation	BPSK, QPSK or 16QAM (adaptive)
FEC rate	FEC 1/2
Receive diversity	Maximum Ratio Combining
Receive sensitivity	-98dBm for most robust mode

### IP interface

Primary & secondary	
Ethernet electrical	100BaseT Ethernet
IP address allocation	DHCP dynamic IP addressing
Video and audio	Multicast VLC compatible
streaming format	UDP & RTSP Support

### Open Audio comms channel (shared voice channel)

Multi-user audio	
comms channel	Interface microphone level/headphone o/p
Compression	G726 32kbit audio

### Encryption

Type	AES128 or AES256 (both optional)
------	----------------------------------

### GPS

Dedicated GPS I/F	RS232/RS485
-------------------	-------------

**Data interface**

RS232/RS485 data 1K2 to 115K2 baud switchable  
With UDP and TCP routing protocol

**Control**

Local control LEDs power and mesh status  
Remote control Mission Commander PC application  
Full control of all parameters in a map based application  
Web browser control

**Physical**

Mass 82g

**Power**

DC input 12-14V  
Power consumed 1W Up to 14W max

**Environment**

Temperature rating -10°C to +50°C

**A/V input option**

Video input Composite or SDI (selectable)  
Video format 525 or 625 (PAL or NTSC)  
Video encoding MPEG4  
Quality Low/Medium/High (selectable)  
Video bit-rate 2.4Mb/s to 50kb/s (variable)  
Resolution 704, 576, 480 or 352  
Frame rate Self-selecting 30 to 2F/s  
Audio input Line level or microphone level  
Audio sample freq. 48KHz  
Audio encoding MPEG audio layer 1  
Audio bit-rate 384 to 64kb/s

**Store and forward options\***

Storage format SD card interface (Secure Digital card) – optional  
Record options Continuous or triggered  
Files download From web browser interface (Milestone)  
AV clip size 30 seconds

\* asterisk means what?

## Connector Pin outs

### J1 Aux Power Out

4-Way 1.5mm JST

Pin	Function
1	+12V
2	+12V
3	Ground
4	Ground

### J2 Power Input

4-Way 2mm JST

Pin	Function
1	$V_{in}$
2	$V_{in}$
3	Ground
4	Ground

### J3 RS485 Serial Data Port

6-Way 1.5mm JST

Pin	Function
1	RS485 TX-
2	RS485 TX+
3	Ground
4	RS485 RX-
5	RS485 RX+
6	Couldn't tell

### J4 Power to D550 Encoder

4-Way 1.5mm JST

Pin	Function
1	$V_{in}$
2	$V_{in}$
3	Ground
4	Ground

### J5 1W Amplifier Power and Enable

5-Way 2mm JST

Pin	Function
1	V <sub>in</sub>
2	V <sub>in</sub>
3	Ground
4	Ground
5	Enable

### J6 RF Output

SMP

### J7 RS232 Serial Control

3-Way 1.5mm JST

Pin	Function
1	RS232 TX
2	RS232 RX
3	Ground

### J8 BDM/JTAG (Reserved)

26-Way 1.27mm pitch male IDC

### J9 RS232 to control D550 Encoder

3-Way 1.5mm JST

Pin	Function
1	RS232 TX
2	RS232 RX
3	Ground

### J10 Talkback Audio connections

6-Way 1.5mm JST

Pin	Function
1	Audio In 1
2	Audio In 2
3	Audio Ground
4	Audio Out 1
5	Audio Out 2
6	Audio Ground

### J11 Connections to D550 Encoder

6-Way 1.5mm JST

Pin	Function
1	Clock In
2	Data In
3	Ground
4	Clock Out
5	Data Out
6	Ground

### J12 RS232 External Serial Data Ports

6-Way 1.5mm JST

Pin	Function
1	RS232 TX1
2	RS232 RX1
3	Ground
4	RS232 TX2
5	RS232 RX2
6	Ground

### J13 RTC Battery connector

### J14 External 10/100 Base-T Ethernet Port

4-Way 1.5mm JST

Pin	Function
1	ETH_OP
2	ETH_ON
3	ETH_IP
4	ETH_IN

### J15 External Secondary 10/100 Base-T Ethernet Port

4-Way 1.5mm JST

Pin	Function
1	ETH_OP
2	ETH_ON
3	ETH_IP
4	ETH_IN

### J16 USB connector (Not currently used)

4-Way 1.5mm JST

Pin	Function
1	USB Power
2	USB Data –
3	USB Data +
4	Ground

### J17 LED Drive

4-Way 1.5mm JST

Pin	Function
1	Ground
2	3.3V in
3	LED1
4	LED2

### J18 Power over Ethernet

4-Way 1.5mm JST

Pin	Function
1	PoE for Port 1 Tx
2	PoE for Port 1 Rx
3	PoE for Port 0 Tx
4	PoE for Port 0 Rx

### J19 Antenna B (Rx 1)

SMP

### J20 SD Card Management

15-Way ZF5-15

Pin	Function	Pin	Function
1	3.3V in	2	3.3V in
3	STATUS_RED	4	SD_CARD_PROTECT
5	STATUS_GREEN	6	SD_CARD_DETECT
7	SPARE_RED	8	SD_CARD_DATA_OUT
9	SPARE_GREEN	10	SD_CARD_CLK
11	Ground	12	SD_CARD_DATA_IN
13	Ground	14	SD_CARD_CS
15	Ground		

**J21 (not on board)**

**J22 Antenna A (Tx Rx 0)**

SMP

**J23 (not on board)**

**J24 RF Out**

SMP

## Mounting Considerations

The following steps should be followed when mounting the D17XX PCB.

Note: Should these guidelines be ignored, performance may suffer and the board may be damaged permanently.

### Heat sinking

The Microprocessor (U28D17XX) and FPGA (U3D17XX) require thorough heat sinking to a metal mounting plate, as indicated in Figure 3. Failure to install such provisions will damage both components.

### Connector clearance

Provision should be made for any ribbon cables as they cannot be folded in the first 10mm at either end of termination. The same is true for SMA connectors. All JST's are a similar height to the Tin cans on each card.



## Turning On the System

[Extract taken from the D1705 TP v1.1 and as such, Tera Term figures will refer to this variant]

### 1. Test Setup

Connect the following cables to the D17XX PCB, as shown in Figure 5.

- Power Cable from external PSU to J2
  - Set supply to 12V 1.5A
- CA0364 to J14 (Connect Ethernet cable to CA0364 – not shown)
- CA0001/CA0149 to J12
- If D550 encoder is desired (not shown):
  - D55x Custom loom to J4, J9, J11
  - CA0186 to J7 on D576

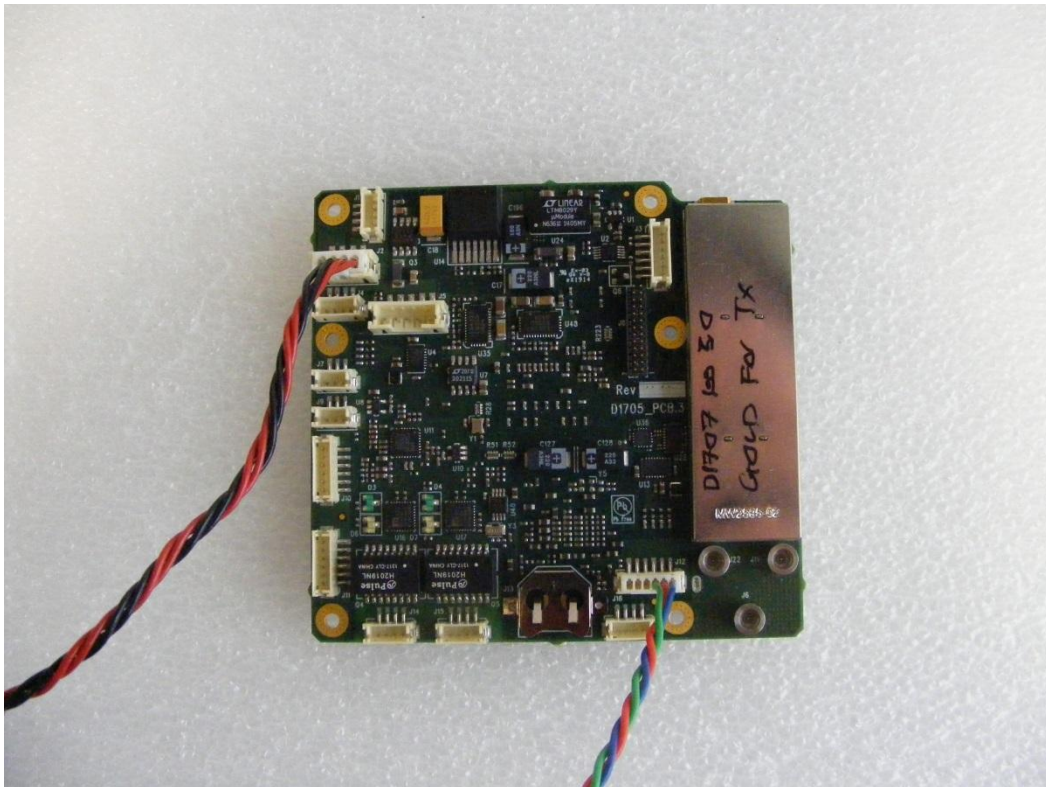
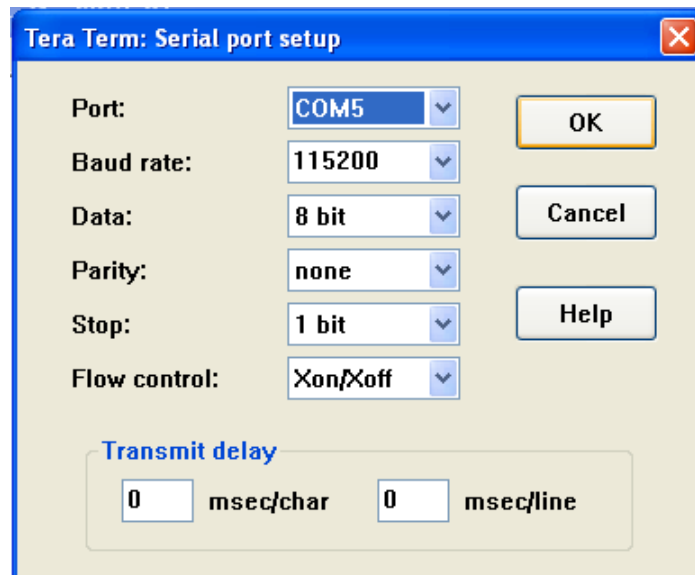

**Figure 5: Initial setup cabling**

### 2. Initial Setup

#### 2.1 Setting unit type

Launch a Tera Term window and configure a serial port connection with the settings shown in Figure 6. Note that the port number will depend on your hardware setup and may well vary from that shown below.



**Figure 6: Tera Term serial port settings**

Power up the unit. In the Tera Term window, press `ctrl d, c` and then `u` during boot-up to navigate to the unit type selection. Select the option that applies to unit under test and power down the unit.

## 2.2 Software updates

If an update of the board's software is required at any time, [<how to do tftp?>](#).

Power down the unit.

## 3. Verify the RF RX performance

### Splitter and cable loss set-up

- In order to test receive performance, the initial RF input level to the D17XX will need to be set to -85dB at J19 and J22 whilst accounting for losses in cables and the splitter.
- Press `Preset` on the Spectrum Analyser. Set the Signal Generator and Spectrum Analyser centre frequency to the mid-range of the bandwidth of the particular unit type.
- Connect the Signal Generator RF output via an N-SMA adaptor to the Splitter 'S' input using an SMA-SMA cable.
- Connect 2 x CA0271 SMA-SMA cables to output Ports 1 and 2 on the Splitter.
- Set the Signal Generator amplitude to -85dB and set Modulation to Off.
- Connect one of the CA271 cables from the Splitter to the input of the Spectrum Analyser, with a DC Block connected at the Analyser input and an N-SMA adaptor.
- Connect a 50Ω Termination or a 20dB Attenuator to the end of the other cable.
- Set the Amplitude Ref Level to -40dBm and Span to 500kHz.
- Set the Signal Generator RF Output ON, observe the signal on the Analyser and press `MKR`, Peak Search.

- Adjust the Signal Generator RF Amplitude until the displayed Marker Level is at -85dB. Leave the amplitude set at this level. Set the Generator output to OFF.
- Swap the 50Ω Termination (or 20dB Attenuator) and the connection to the Analyser.
- Set the Signal Generator output to ON and check the Marker level on the Analyser is within 0.3dB of the level set previously. Set the Signal Generator output to OFF.

### Noise Figure Tests

- Disconnect the cable from the Analyser and the 50Ω Termination (or 20dB Attenuator) from the Splitter cable. Connect both cables from the Splitter to J19 and J22 (both SMP) of the D1705. Set-up should be as per Figure 7.

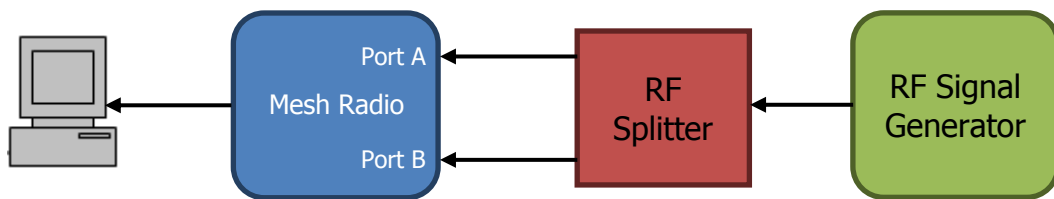

**Figure 7: RF Rx test set-up**

- Power up the D17XX and upon initial boot up press `ctrl d, c` and then `m` in the Tera Term window to enter Demodulator Test mode as shown in Figure 8. The D17XX will initially enter the Noise Figure Measurement mode.

```

COM3:115200baud - Tera Term VT
File Edit Setup Control Window Help
Unit Serial Number: 0x74decd2b
Unit Type:
I: <01> - D1705_D - Agile Integrated L-Band 1250-1450MHz TX/RX

Software version: v5.4b
Built: May 16 2014
FPGA version: 0x12
Board type: 0xa9

Test Demodulator:

Noise Figure measurement
Setting demod frequency to 1250 MHz:

Connect Signal generator through spitter to all RF inputs.
  turn on CW signal setting -85dBm level at each RF input
  <x> to take measurement
saw_sel = 0
Freq = 1250.000000
vf = 188 188
vf = 188 188

PwrA = -40.3, PwrB = -40.4,
PwrA = -40.4, PwrB = -40.4,
PwrA = -40.4, PwrB = -40.5,
PwrA = -40.4, PwrB = -40.5,

```

**Figure 8: Demodulator Test mode initial display**

- Set the Signal Generator to the initial test frequency displayed on Tera Term (1250MHz in Figure 8) plus an additional 200kHz and set RF Output to ON.
- Press **x** to take measurements.

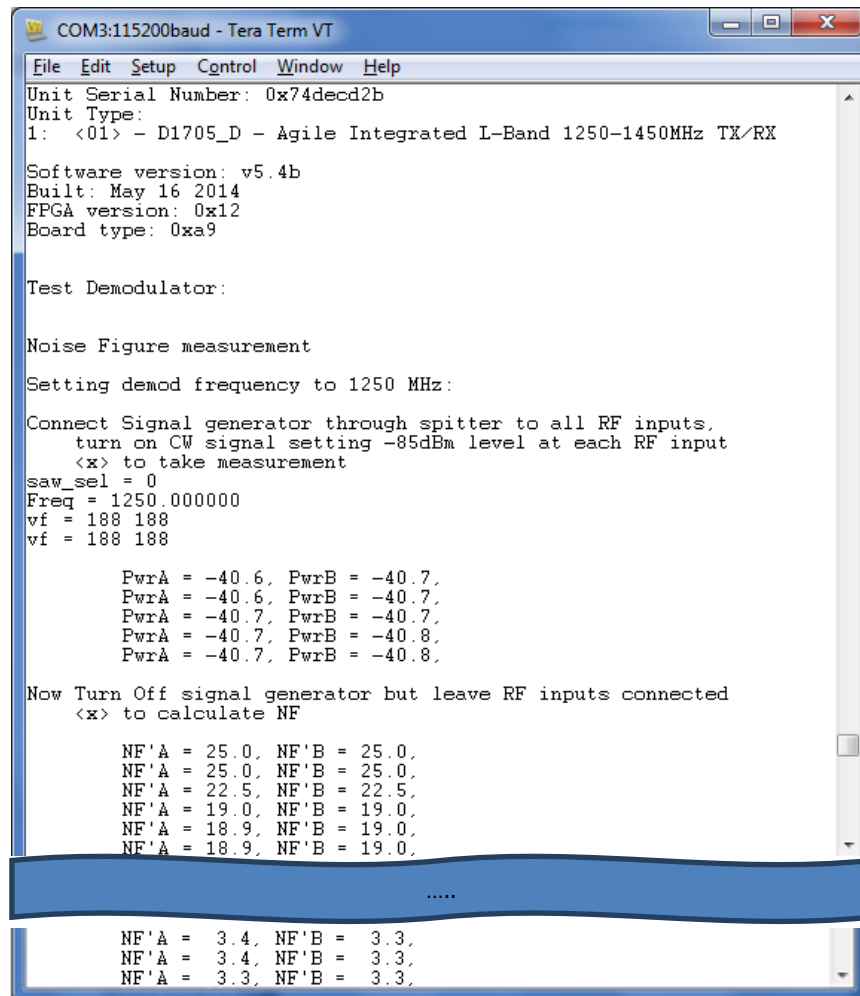

```

COM3:115200baud - Tera Term VT
File Edit Setup Control Window Help
Unit Serial Number: 0x74decd2b
Unit Type:
1: <01> - D1705_D - Agile Integrated L-Band 1250-1450MHz TX/RX

Software version: v5.4b
Built: May 16 2014
FPGA version: 0x12
Board type: 0xa9

Test Demodulator:

Noise Figure measurement

Setting demod frequency to 1250 MHz:

Connect Signal generator through splitter to all RF inputs.
turn on CW signal setting -85dBm level at each RF input
<x> to take measurement
saw_sel = 0
Freq = 1250.000000
vf = 188 188
vf = 188 188

PwrA = -40.6, PwrB = -40.7,
PwrA = -40.6, PwrB = -40.7,
PwrA = -40.7, PwrB = -40.7,
PwrA = -40.7, PwrB = -40.8,
PwrA = -40.7, PwrB = -40.8,

Now Turn Off signal generator but leave RF inputs connected
<x> to calculate NF

NF'A = 25.0, NF'B = 25.0,
NF'A = 25.0, NF'B = 25.0,
NF'A = 22.5, NF'B = 22.5,
NF'A = 19.0, NF'B = 19.0,
NF'A = 18.9, NF'B = 19.0,
NF'A = 18.9, NF'B = 19.0,
.....
NF'A = 3.4, NF'B = 3.3,
NF'A = 3.4, NF'B = 3.3,
NF'A = 3.3, NF'B = 3.3,

```

**Figure 9: Noise Figure test complete**

- Press **x** to calculate the Noise Figure, turn the RF output OFF and allow the readings to stabilise. Examining the output results, verify that all measurements are **≤6dB**, and confirm that the difference between the two inputs is **<2dB**, as shown in Figure 9.
- Press **x** again to proceed to the next Test Frequency. Set the Signal Generator Frequency to match the displayed Test Frequency +200kHz and turn the RF output back ON.
- Follow the above steps on Tera Term for each test frequency, remembering to add a +200kHz offset to the test frequency displayed on Tera Term. Again, confirm the Noise Figure is **≤6dB** with the difference between the two inputs **<2dB** for each test frequency.

### LNA Gain Tests

- When the final Noise Figure test has been completed the LNA gain tests will be initiated. Set the Signal Generator to the initial test frequency +200kHz as displayed on Tera Term at -85dB level measured at set-up.

- Set the RF output of the Signal Generator to ON and verify the gain lies within the limits laid out in Table 3.

Frequency [MHz]	Max Gain [dB]	Min Gain [dB]
1250	-22	-27
1340	-19	-24
1400	-20.5	-25.5
1450	-23	-28

**Table 3: LNA gain limits**

- Press  $\times$  to continue through to the next gain frequency, remembering to add 200kHz to all indicated test frequencies on the Signal Generator and refer to Table 3 to verify the limits.
- Continue this process for all gain test frequencies. Press  $\times$  to complete the LNA Gain Tests and turn the Signal Generator RF output OFF.

#### 4. Verify the RF TX performance

- Plug in the RF cable to a Power Meter via the RF output (J24) on the D17XX.
- Cycle the power on the unit and upon initial boot up `ctrl d, c` and then `t` to enter power test mode, as shown in Figure 10.

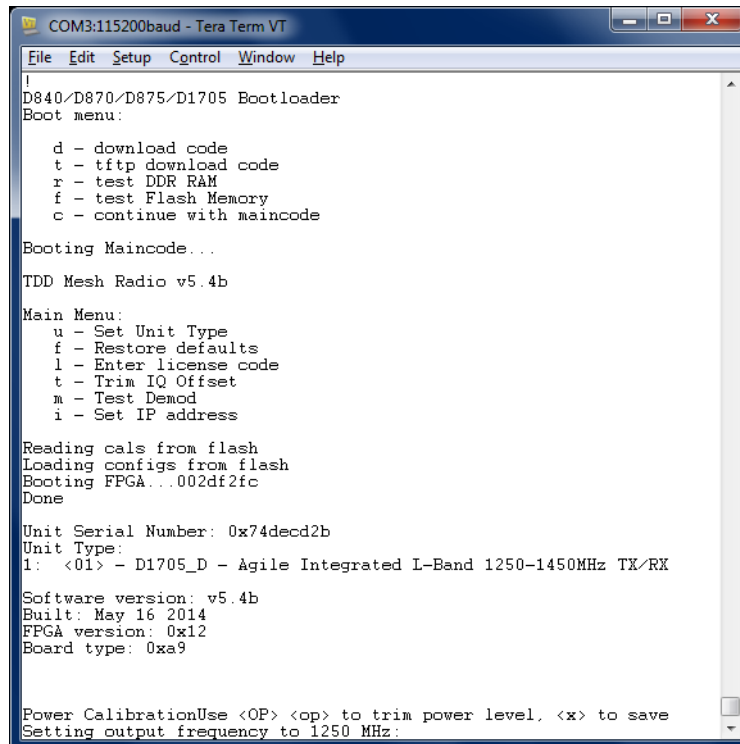

```

COM3:115200baud - Tera Term VT
File Edit Setup Control Window Help
!
D840/D870/D875/D1705 Bootloader
Boot menu:

d - download code
t - tftp download code
r - test DDR RAM
f - test Flash Memory
c - continue with maincode

Booting Maincode...

TDD Mesh Radio v5.4b

Main Menu:
u - Set Unit Type
f - Restore defaults
l - Enter license code
t - Trim IQ Offset
m - Test Demod
i - Set IP address

Reading cals from flash
Loading configs from flash
Booting FPGA...002df2fc
Done

Unit Serial Number: 0x74decd2b
Unit Type:
1: <01> - D1705_D - Agile Integrated L-Band 1250-1450MHz TX/RX

Software version: v5.4b
Built: May 16 2014
FPGA version: 0x12
Board type: 0xa9

Power CalibrationUse <OP> <op> to trim power level, <x> to save
Setting output frequency to 1250 MHz:

```

**Figure 10: Power calibration display in Tera Term**

- The output power needs to be checked over a range of frequencies automatically pre-defined in the software relating to the particular type of the unit. Using the  $\circ$  and  $\text{p}$  keys to adjust the output power, confirm on the Power Meter that the minimum RF Output the D17XX can provide is **>21.5dBm**, regardless of Tera Term setting.
- Adjust the output power at the first trim frequency to **20.0dBm**  $\pm$  0.25dB in Tera Term. Press  $\times$  and proceed to the next trim frequency.
- Perform the same test for each trim frequency.
- Press  $\times$  after the last Power Calibration Frequency to proceed to the Shoulder Performance section.

## 5. Spectrum Verification

- Disconnect the Power Meter Sensor and reconnect the RF Out to the Spectrum Analyser.
- Set the Spectrum Analyser Span to 10MHz, Res B/W to 10KHz, and Video B/W to 30KHz.
- Confirm the Spectrum Analyser display is similar to that shown in Figure 11.

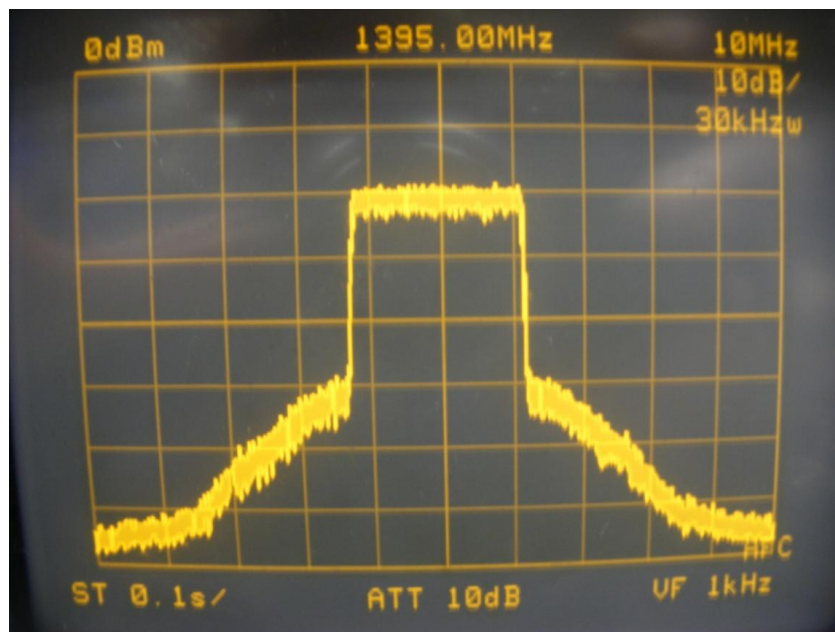

**Figure 11: Shoulder performance**

- Measure and confirm the level between the display top and the Shoulder is **>25dB**. This test only needs to be carried out at the first trim Frequency.

## 6. Set RTC Clock

- With the D17XX powered **down** insert a CR1220 battery into J13 and power up the unit.
- Open a web browser and navigate to the IP address of the D17XX PCB (See section 10 below)

- Navigate to global Settings and click on the Set Clock button.
- Set the clock to the current date and time, and power down the D17XX.

## 7. Ethernet Video Streaming

**UDP Multicast** video streaming is selected in the web interface under Global Parameters as follows:

- Streaming Status: Enabled
- Streaming Type: UDP Multicast

The UDP Multicast video stream can be accessed from a player like domo Stream Player, VLC Media Player or Cobham Mission Commander at the default address and port:

- Multicast address: 224.2.128.12
- Multicast Port: 10333

These parameters can be edited under Global Parameters.

**RTSP Multicast** video streaming is selected under Global Parameters as follows:

- Streaming Status: Enabled
- Streaming Type: RTSP Multicast

The RTSP Multicast stream can be accessed from a player like VLC Media Player or Cobham Mission Commander (not supported by domo Stream Player):

- `rtsp://unit_ip_address/stream.sdp`
- e.g. `rtsp://192.168.2.193/stream.sdp`

## 8. Recording and Playback

Before the first recording to the onboard SD card, the following steps should be followed:

- With the D550 powered off, insert a Sandisk MicroSD card in the onboard MicroSD card holder. Card capacities supported: 2GB to 32GB.
- Insert a 3V coin cell battery into J7. This will power the Real Time Clock when the system is powered off.
- Turn on the system.
- If a new card was inserted, format the SD card via the web browser Global Settings page. This will erase all the data on the card.
- Set the Real Time Clock via the web browser Global Settings page, in the same way as for the D17XX.
- Turn on recording on the Global Settings page.

Note: **Recording in DVB-T is not supported.** The highest bitrate supported for recording is 2.5Mb/s. In Narrowband this corresponds to 2.5MHz, QPSK, 2/3 FEC

When recording at 2.5Mb/s, a 32GB SD card will provide up to 29 hours of recording time. Lower bitrates will increase the record time.

When the card gets full, recording is automatically stopped.

Playback of recordings is done via RTSP Unicast from a player like VLC Media Player or Cobham Mission Commander (not supported by domo Stream Player):

- `rtsp://unit_ip_address/record.sdp`
- e.g. `rtsp://192.168.2.193/record.sdp`

Note: Simultaneous recording and playback is NOT supported at this stage and will lead to stuttery recording and playback and possibly corrupt the recording.

## 9. Direct connection to PC

- Should there be a need for direct connection to a PC without a network, DHCP should be disabled on the D17XX and the user should assign a static IP address to the unit.
- Power down the unit and connect to the PC's Ethernet port via J14.
- Configure the PC to have TCP/IP DHCP disabled, and assign a static IP address to the PC in the same network IP class as the D17XX.
- Power up the D17XX and observe the assigned IP address in Tera Term. From the PC, browse to the address, as described in the previous section.

## 10. Serial RS232 Control

The following section describes the control protocol employed on the RS232 link for controlling the D550 board.

### RS232 Control – General Principles

The physical interface is RS232 but this can be converted to RS485 with an external adapter where multiple units are controlled over one RS 485 bus.

Normal operation involves sending a packet from the control device (normally a PC) to the device being controlled. If the packet satisfies an address integrity check, then the controlled device will action the command and send a reply.

For compatibility with modems an ASCII style protocol is used.

Ports are set for **115200 baud, 8 bits, No parity, 1 stop**.

### Command Packet Structure

ASCII	Value	
STX	02h	Start byte
0-9	30h-39h	4 byte unit address. In range 0-9999
R	20h-7Eh	1 byte command type. <b>r</b> read, <b>w</b> write
ABCD	20h-7Eh	Command –four byte mnemonic
;	3Bh	Separator
PQR	20h-7Eh	Data –Optional, variable length
;	3Bh	Separator
X	80h-FFh	Checksum
ETX	03h	End byte

### Reply Packet Structure

ASCII	Value	
STX	02h	Start byte
0-9	30h-39h	4 byte unit address. In range 0-9999



Z	20h-7Eh	Status BYTE
PQR	20h-7Eh	Data –Optional, variable length
;	3Bh	Separator
X	80h-FFh	Checksum
ETX	03h	End byte

The checksum byte is a summation of all bytes in the packet, not including the start (02h) and end (03h) bytes. The result is then modified by forcing bit 7 high to prevent ASCII control characters from being sent. The resulting checksum is in the range of 80h - FFh.

The Status byte will indicate if the command performed OK, or indicate an error:

ASCII	Meaning
-------	---------

1	All OK
---	--------

E	General error, Command could not be executed
---	--

Typically E will be returned if the message is formatted incorrectly (separators in wrong place) or if commands are in upper case, or if commands do not match against the allowed list of commands, or if the checksum is wrong.

Addresses in the range 0001 to 9998 are for general use. Address 0000 is reserved and 9999 is a broadcast address. i.e. any device will reply to this address. Its reply will contain its own specific address.

All data in the transmitter and receiver is stored as one of 5 data types, Double, Integer String, or Hexadecimal integer. The data type dictates the contents of the data section of the reply.

- *Double – Data always contains decimal point and 2 decimal places. Can have 1 to 4 digits before decimal.*
- *Integer –Data is 5-byte reply of integer value stuffed with preceding zeros. E.g. current preset reply 00006 = preset 6 is live.*
- *String – Data is variable length string excluding null terminator.*
- *Hex – Data should be interpreted as hexadecimal number of variable length.*

## Control Commands

### Mesh Command List V3.1

Group: Audio	Command	Name	FCON	Type	R/W	Scope	Options
Advanced Commands	<a href="#">aana</a>	Audio Stream Name	Stream Name	string		Config	String length = 17
	<a href="#">ahea</a>	Headphone Gain	Head gain	integer		Config	
	<a href="#">amic</a>	Mic Gain	Mic Gain	integer		Config	
	<a href="#">amut</a>	Mute Level	Mute Lev	integer		Config	
	<a href="#">arn</a>	Audio Enable	Aud En	intList		Config	0 = No 1 = Yes 2 = Rem

The command **aana** allows a name to be assigned to an audio stream from a particular NETNode.

The command **ahea** sets the gain level of headphone for the **talk back audio..** Cobham suggests that the user experiments on the Web browser with gain levels and reads back the command to understand the effect of the parameter on the headset.

The command **amic** sets the digital gain applied to the microphone input for the **talk back audio.** Cobham suggests that the user experiments on the Web browser with gain levels and reads back the command to understand the effect of the parameter on the chosen microphone.

The command **amute** sets the 'squelch' level on the **talkback audio input.** Adjusting this parameter adjusts the background noise level that is 'muted' by default and not transmitted.

The command **arn** enables or disables the **talkback audio** on the mesh node.

Group: Chaining	Command	Name	FCON	Type	R/W	Scope	Options
Advanced Commands	<a href="#">gcha</a>	Chain Status	Chain Lock	intList		Global	0 = No 1 = Yes
Group: Config	Command	Name	FCON	Type	R/W	Scope	Options
Main Commands	<a href="#">ddef</a>	Restore Default	Defaults	intList		Memory	0 = No 1 = Yes
	<a href="#">dlas</a>	Last Config	Cur Cfg	integer	Read Only	Memory	
	<a href="#">dloa</a>	Load Config	Load Cfg	config		Memory	0 = Current 1 = 1 2 = 2 3 = 3 4 = 4 5 = 5 6 = 6 7 = 7 8 = 8
	<a href="#">dsto</a>	Store Config	Save Cfg	config		Memory	0 = Current 1 = 1 2 = 2 3 = 3 4 = 4 5 = 5 6 = 6 7 = 7 8 = 8

Group: Data	Command	Name	FCON	Type	R/W	Scope	Options
Main Commands	<a href="#">tbau</a>	Data 0 Baudrate	Baud	intList		Config	0 = None 1 = Invalid Option 2 = 1200 3 = 2400 4 = 4800 5 = 9600 6 = 19200 7 = 38400 8 = 57600 9 = 115200
	<a href="#">tdat</a>	Data 0 Mode	Mode	intList		Config	0 = None 1 = UDP 2 = TCP Server 3 = TCP Client
	<a href="#">tiad</a>	Data 0 IP Address	IP Addr	ipAddress String		Config	
	<a href="#">tipo</a>	Data 0 IP Port	IP Port	integer		Config	
	<a href="#">tpar</a>	Data 0 Parity	Parity	intList		Config	0 = None 1 = Even 2 = Odd
	<a href="#">ubau</a>	Data 1 Baudrate	Baud	intList		Config	0 = None 1 = Invalid Option 2 = 1200 3 = 2400 4 = 4800 5 = 9600 6 = 19200 7 = 38400 8 = 57600 9 = 115200
	<a href="#">udat</a>	Data 1 Mode	Mode	intList		Config	0 = None 1 = UDP 2 = TCP Server 3 = TCP Client
	<a href="#">uiad</a>	Data 1 IP Address	IP Addr	ipAddress String		Config	

	<a href="#">uipo</a>	Data 1 IP Port	IP Port	integer		Config	
	<a href="#">upar</a>	Data 1 Parity	Parity	intList		Config	0 = None 1 = Even 2 = Odd
<b>Advanced Commands</b>	<a href="#">vbau</a>	Data 2 Baudrate	Baud	intList		Config	0 = None 1 = Invalid Option 2 = 1200 3 = 2400 4 = 4800 5 = 9600 6 = 19200 7 = 38400 8 = 57600 9 = 115200
	<a href="#">vdat</a>	Data 2 Mode	Mode	intList		Config	0 = None 1 = UDP Server 2 = TCP Server 3 = TCP Client
	<a href="#">viad</a>	Data 2 IP Address	IP Addr	ipAddress String		Config	
	<a href="#">vipo</a>	Data 2 IP Port	IP Port	integer		Config	
	<a href="#">vpar</a>	Data 2 Parity	Parity	intList		Config	0 = None 1 = Even 2 = Odd

Group: IP	Command	Name	FCON	Type	R/W	Scope	Options
Main Commands	<a href="#">icom</a>	Comp disable	Comp Dis	intList		Global	0 = Off 1 = On
	<a href="#">idga</a>	DHCP Gateway	DHCP GW	ipAddress String	Read Only	Global	
	<a href="#">idhc</a>	DHCP enable	DHCP En	intList		Global	0 = Off 1 = On
	<a href="#">idma</a>	DHCP Netmask	DHCO NM	ipAddress String	Read Only	Global	
	<a href="#">idsb</a>	DHCP IP Address	DHCP IP	ipAddress String	Read Only	Global	
	<a href="#">ifob</a>	FoByte count	For Cnt	hexString	Read Only	Global	
	<a href="#">ifor</a>	Forward count	For Cnt	integer	Read Only	Global	
	<a href="#">igps</a>	GPS source	GPS Src	intList		Config	0 = Off 1 = RS232 2 = RS485 3 = Encoder
	<a href="#">inam</a>	Stream Name	Stream Name	string		Config	String length = 17
	<a href="#">ipga</a>	Static Gateway	Gateway	ipAddress String		Global	
	<a href="#">ipma</a>	Static Netmask	Netmask	ipAddress String		Global	
	<a href="#">ipsb</a>	Static IP Address	IP Addr	ipAddress String		Global	
	<a href="#">irec</a>	Record Mode	Rec Mode	intList		Config	0 = Off 1 = On
	<a href="#">irle</a>	RLen File	Rec File Len	integer		Config	
	<a href="#">irxe</a>	RxError count	RX Err	integer	Read Only	Global	
	<a href="#">irxp</a>	RxPacket count	RX Pkt Cnt	integer	Read Only	Global	
	<a href="#">isad</a>	Saddr stream	Stream IP	ipAddress String		Config	
	<a href="#">isap</a>	SAP addr	SAP Addr	ipAddress String		Config	
	<a href="#">ids</a>	Sdst Multicast Mask	Dest Mask	integer		Config	
	<a href="#">ispo</a>	SPort Stream	Stream Port	integer		Config	
<a href="#">issr</a>	Ssrc	Src Mask	integer		Config		

		Multicast Mask						
	<a href="#">itok</a>	Token Count	Tok Cnt	integer	Read Only	Global		
	<a href="#">itxb</a>	TxByte count	TX Cnt	hexString	Read Only	Global		
	<a href="#">itxo</a>	TxOverflow count	TX Ovfl	integer	Read Only	Global		
	<a href="#">itxp</a>	TxPacket count	TX Pkt Cnt	integer	Read Only	Global		
<b>Advanced Commands</b>	<a href="#">ilmo</a>	1Mode VLAN	VLAN 1 Mode	intList		Global	0 = Transparent 1 = LAN<->VLAN 2 = VLAN<->LAN 3 = Off	
	<a href="#">ilpr</a>	1Pri VLAN	VLAN 1 Pri	integer		Global		
	<a href="#">ilta</a>	1Tag VLAN	VLAN 1 Tag	integer		Global		
	<a href="#">i2mo</a>	2Mode VLAN	VLAN 2 Mode	intList		Global	0 = Transparent 1 = LAN<->VLAN 2 = VLAN<->LAN 3 = Off	
	<a href="#">i2pr</a>	2Pri VLAN	VLAN 2 Pri	integer		Global		
	<a href="#">i2ta</a>	2Tag VLAN	VLAN 2 Tag	integer		Global		
	<a href="#">itip</a>	TIP address	TIP Addr	ipAddressString		Global		
	<a href="#">itun</a>	Tunnel Mode	Tun Mode	intList		Global	0 = Off 1 = Master 2 = Slave	
	<b>Group: Mesh</b>	<b>Command</b>	<b>Name</b>	<b>FCON</b>	<b>Type</b>	<b>R/W</b>	<b>Scope</b>	<b>Options</b>
	<b>Main Commands</b>	<a href="#">mipf</a>	IP Forward	IP Fwd	intList		Config	0 = No 1 = Yes 2 = OldAlgm
<a href="#">mmes</a>		Mesh ID	Mesh ID	integer		Config		
<a href="#">mnod</a>		Node ID	Node ID	intList		Config	0 = Node0 1 = Node1	

							2 = Node2 3 = Node3 4 = Node4 5 = Node5 6 = Node6 7 = Node7
<b>Advanced Commands</b>	<a href="#">mflo</a>	Flow Rate	Flow Rate	double		Config	
<b>Group: RF</b>	<b>Command</b>	<b>Name</b>	<b>FCON</b>	<b>Type</b>	<b>R/W</b>	<b>Scope</b>	<b>Options</b>
<b>Main Commands</b>	<a href="#">gloc</a>	Lock	RF Lock	intList	Read Only	Global	0 = No 1 = Yes
	<a href="#">ofre</a>	Modulation Frequency	Freq	double		Config	MHz
	<a href="#">ohls</a>	Output Level Select	RF Hi/Lo	intList		Config	0 = Low 1 = High
	<a href="#">olev</a>	Output Level High	Atten High	integer		Config	dB
	<a href="#">ollv</a>	Output Level Low	Atten Low	integer		Config	dB
	<a href="#">oout</a>	Modulation output	RF Out	intList		Config	0 = Off 1 = On
	<a href="#">owid</a>	Modulation Bandwidth	B/W	intList		Config	0 = 2.5MHz 1 = 3.0MHz 2 = 3.5MHz
<b>Group: Scram</b>	<b>Command</b>	<b>Name</b>	<b>FCON</b>	<b>Type</b>	<b>R/W</b>	<b>Scope</b>	<b>Options</b>
<b>Main Commands</b>	<a href="#">zae5</a>	AES Scrambling Key - upper 128 bits used in AES256 only	AES Key 2	hexString	Write Only	Config	
	<a href="#">zaes</a>	AES Scrambling Key - lower 128 bits	AES Key 1	hexString	Write Only	Config	
	<a href="#">zclr</a>	Clear Keys	Clear	intList		Global	0 = No 1 = Yes
	<a href="#">zdes</a>	Scrambling	Descram	intList		Config	0 = Off 1 = Invalid Option 2 = Invalid Option 3 = Invalid Option



4 = AES  
128  
5 = AES  
128+  
6 = AES  
256  
7 = AES  
256+

Group: Unit	Command	Name	FCON	Type	R/W	Scope	Options
Main Commands	<a href="#">gfpg</a>	FPGA version	FPGA	integer	Read Only	Global	
	<a href="#">gnam</a>	Name Unit	Unit	string		Global	String length = 13
	<a href="#">gnda</a>	NData	Num Dat Chan	integer	Read Only	Global	
	<a href="#">gsof</a>	Soft version	S/W Ver	string	Read Only	Global	String length = 5
Advanced Commands	<a href="#">gadd</a>	Address	Addr	integer		Global	
	<a href="#">gaut</a>	Auto Set Time from GPS	GPS Time	intList		Global	0 = No (Default) 1 = Yes
	<a href="#">gaux</a>	Aux Address	Aux Addr	integer		Global	
	<a href="#">gbat</a>	BatType	Batt Type	intList	Read Only	Global	0 = 12V
	<a href="#">gbcn</a>	Bcnt	Pwrups	integer	Read Only	Global	
	<a href="#">gbvo</a>	BVoltage	Batt Volt	integer	Read Only	Global	%
	<a href="#">gcom</a>	Comm IP	Comm IP	intList	Read Only	Global	0 = Local 1 = Remote
	<a href="#">gctr</a>	Ctrl Port Select	Ctrl Port	intList		Global	0 = RS232_1/R S232_2 1 = RS232_2/R S232_1
	<a href="#">gdat</a>	Date	Date	string		Global	String length = 11
	<a href="#">gday</a>	Daylight Saving Offset	DST Ofs	integer		Global	Hr
	<a href="#">getm</a>	Etmi	Elapsed	integer	Read Only	Global	
	<a href="#">gext</a>	Ext Pwr Enable	Ext Pwr	intList		Global	0 = Off 1 = On

<a href="#">gmac</a>	MAC address	MAC	string	Read Only	Global	String length = 12	
<a href="#">goct</a>	Oct Switch Enable	Oct Sw En	intList		Global	0 = Off 1 = On	
<a href="#">goti</a>	Otim	Run Time	integer	Read Only	Global		
<a href="#">gpas</a>	Password	Pass	string		Global	String length = 13	
<a href="#">grel</a>	Relay Only	Rel Only	intList		Global	0 = No 1 = Yes	
<a href="#">grem</a>	Remote Lock	Rem Lock	intList		Global	0 = No 1 = Yes	
<a href="#">grtc</a>	RTC have	RTC OK	intList		Global	0 = No 1 = Yes	
<a href="#">grtp</a>	RTP Enable	RTP En	intList		Global	0 = Off 1 = Multicast 2 = Unicast	
<a href="#">gsdm</a>	SdMmc Card	SD Card OK	intList		Global	0 = No 1 = Yes	
<a href="#">gser</a>	SerNum	ESN	hexString	Read Only	Global		
<a href="#">gspe</a>	Speed Units	Speed	intList		Global	0 = Knots 1 = MPH 2 = KPH	
<a href="#">gtim</a>	Time	Time	string		Global	String length = 9	
<a href="#">gtra</a>	Track Enable	Track	intList		Global	0 = Off 1 = On	
<a href="#">gtzo</a>	Tzone	Time Zone	integer		Global	1/4hr	
<a href="#">gweb</a>	WEB Control	Web Cont	intList		Global	0 = Off 1 = ReadOnly 2 = Full	
<b>Group: VLAN</b>	<b>Command</b>	<b>Name</b>	<b>FCON</b>	<b>Type</b>	<b>R/W</b>	<b>Scope</b>	<b>Options</b>
<b>Advanced Commands</b>	<a href="#">n1pm</a>	1 NetMask	VL NM1	ipAddress String		Config	
	<a href="#">n1sb</a>	1 IP address	VL IP1	ipAddress String		Config	
	<a href="#">n1ta</a>	1Tag	VL Tag1	integer		Config	
	<a href="#">n2pm</a>	2 NetMask	VL NM2	ipAddress String		Config	
	<a href="#">n2sb</a>	2 IP address	VL IP2	ipAddress String		Config	

<a href="#">n2ta</a>	2Tag	VL Tag2	integer	Config	
<a href="#">n3pm</a>	3 NetMask	VL NM3	ipAddress String	Config	
<a href="#">n3sb</a>	3 IP address	VL IP3	ipAddress String	Config	
<a href="#">n3ta</a>	3Tag	VL Tag3	integer	Config	
<a href="#">n4pm</a>	4 NetMask	VL NM4	ipAddress String	Config	
<a href="#">n4sb</a>	4 IP address	VL IP4	ipAddress String	Config	
<a href="#">n4ta</a>	4Tag	VL Tag4	integer	Config	
<a href="#">n5pm</a>	5 NetMask	VL NM5	ipAddress String	Config	
<a href="#">n5sb</a>	5 IP address	VL IP5	ipAddress String	Config	
<a href="#">n5ta</a>	5Tag	VL Tag5	integer	Config	
<a href="#">n6pm</a>	6 NetMask	VL NM6	ipAddress String	Config	
<a href="#">n6sb</a>	6 IP address	VL IP6	ipAddress String	Config	
<a href="#">n6ta</a>	6Tag	VL Tag	integer	Config	
<a href="#">n7pm</a>	7 NetMask	VL NM7	ipAddress String	Config	
<a href="#">n7sb</a>	7 IP address	VL IP7	ipAddress String	Config	
<a href="#">n7ta</a>	7Tag	VL Tag7	integer	Config	
<a href="#">n8pm</a>	8 NetMask	VL NM8	ipAddress String	Config	
<a href="#">n8sb</a>	8 IP address	VL IP8	ipAddress String	Config	
<a href="#">n8ta</a>	8Tag	VL Tag8	integer	Config	