

## Owner's Manual

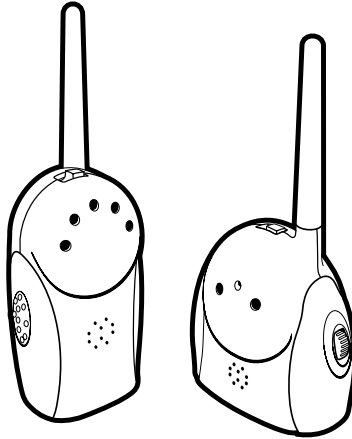

### Introduction

*Thank you for purchasing the Safety 1st Two-Way Intercom Monitor. We are confident that this advanced system will help keep you in tune with your baby's every sound, offering you two-way communication, clear reception, and portability.*

### **Communication**

- *Two-way communication feature lets you soothe baby with your own voice or talk to another adult*
- *Sound Lights let you see baby's sound level*

### **Reception**

- *49 MHz technology provides superior clarity*
- *Extended range up to 400' (122 meters)*
- *Two channels to help minimize interference*

### **Portability**

- *Both Units can run on battery power while you are on the go*
- *Parent's Unit features a handy belt-clip for portability*
- *Units also run on household electricity – two A/C adapters included*

Please read all instructions carefully before using the 49MHz Two-Way Intercom Monitor. Keep these instructions for your future reference. If you have any questions, please call our toll-free Consumer Relations number: (800) 723-3065. In Canada, please call (800) 387-2229.

### CAUTION:

- **THE TWO-WAY INTERCOM NURSERY MONITOR IS NOT INTENDED TO REPLACE RESPONSIBLE AND PROPER PARENTAL SUPERVISION.**
- **YOU SHOULD CHECK YOUR CHILD'S ACTIVITY AT REGULAR INTERVALS AS THIS MONITOR WILL NOT ALERT PARENTS TO THE SILENT ACTIVITIES OF A CHILD.**
- **KEEP ALL PARTS OF THIS MONITOR OUT OF REACH OF CHILDREN!**

 **WARNING:** Changes or modifications to this unit not expressly approved by Safety 1st, Inc. could void the user's authority to use the equipment.

This device complies with part 15 of the FCC Rules. Operation is subject to the following 2 conditions: (1) This device may not cause harmful interference, and (2) this device must accept any interference received, including interference that may cause undesired operation.

The Baby's Unit carrier frequency on channel A is 49.830 MHz and on channel B is 49.845 MHz. The Parent's Unit carrier frequency on channel A is 49.875 MHz and on channel B is 49.890 MHz. The field strength is 80 dB microvolts per meter at 3 meters.

## Safety Instructions

### **WARNING**

- TO REDUCE THE RISK OF FIRE OR ELECTRICAL SHOCK, DO NOT EXPOSE THIS PRODUCT TO WATER OR MOISTURE. NEVER TOUCH THE END OF THE ADAPTER CORD WHEN THE ADAPTER IS PLUGGED INTO AN ELECTRICAL OUTLET.
- TO REDUCE THE RISK OF ELECTRICAL SHOCK, DO NOT REMOVE COVER OR BACK. NO SERVICEABLE PARTS INSIDE. REFER TO SAFETY 1ST CONSUMER RELATIONS: (800) 723-3065. IN CANADA CALL (800) 387-2229.

# Safety Instructions

**HEED WARNINGS:** All warnings on the Two-Way Intercom Monitor and operating instructions should be adhered to.

**WATER AND MOISTURE:** The Two-Way Intercom Monitor should not be used near water, for example, near a bath tub, wash bowl, kitchen sink, laundry tub, in a wet basement, near a swimming pool, etc.

**VENTILATION:** The Two-Way Intercom Monitor should be placed so that its location does not interfere with proper ventilation of the unit. For example, it should never be situated on a bed, sofa, rug or similar surface that may block ventilation.

**HEAT:** The Two-Way Intercom Monitor should be kept away from heat sources such as radiators, heat registers, stoves or other appliances that produce heat.

**AC POWER SOURCE:** The Two-Way Intercom Monitor should be connected only to the AC Adapters supplied with the Unit.

**POWER CORD PROTECTION:** The power supply cord should be routed so that it is not likely to be walked on or pinched by items placed upon or against it. Pay particular attention to the cord at the plug, convenience receptacle, and at the point it exits from the AC Adapters.

**CLEANING:** Use a dry cotton cloth to keep the Two-Way Intercom Monitor free from dust. Do not use water!

**NON-USE PERIODS:** The power cords of the Two-Way Intercom Monitor should be unplugged from the outlet when unused for long periods of time. The batteries should also be removed during these periods.

**OBJECT AND LIQUID ENTRY:** Care should be taken so that objects do not fall onto the product, and liquids are not spilled into the enclosure through the openings.

**DAMAGE REQUIRING SERVICE:** The Two-Way Intercom Monitor should be serviced by qualified personnel when:

- A: The power supply cord or plug has been damaged.
- B: Objects have fallen or liquid has been spilled onto the product.
- C: The Monitor has been exposed to rain.
- D: The Monitor does not appear to operate normally or exhibits a marked change in its performance.
- E: The Monitor has been dropped or the enclosure damaged.

## Contents

### Parent's Unit

(Requires one 9 volt alkaline battery to operate in portable mode. Not included.)

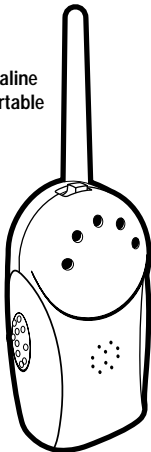

### Baby's Unit

(Requires one 9 volt alkaline battery to operate in portable mode. Not included.)

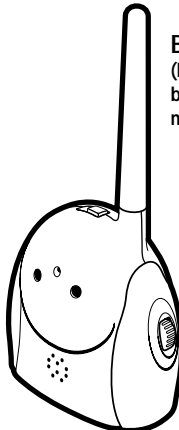

### 2 AC Adapters

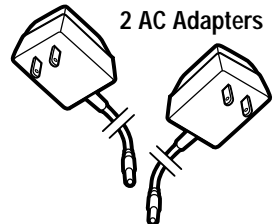

## Features and Components - Parent's Unit

- 1 On/Volume Dial
- 2 Power On (green)/Low Battery (amber) LED Indicator
- 3 Push to Talk Button
- 4 Channel Selector
- 5 LED Sound Lights (4)
- 6 Microphone
- 7 Antenna – turns 90° clockwise to facilitate horizontal belt clip
- 8 AC Adapter Jack
- 9 Belt Clip
- 10 Battery Compartment (1 screw in door)

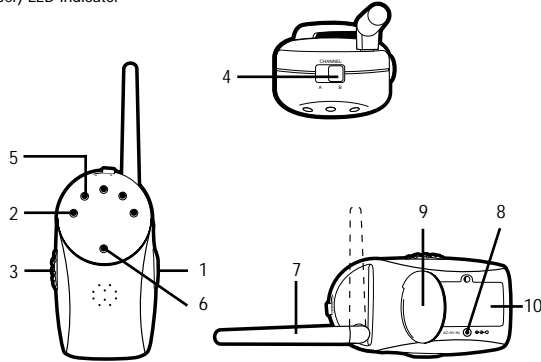

## Features and Components - Baby's Unit

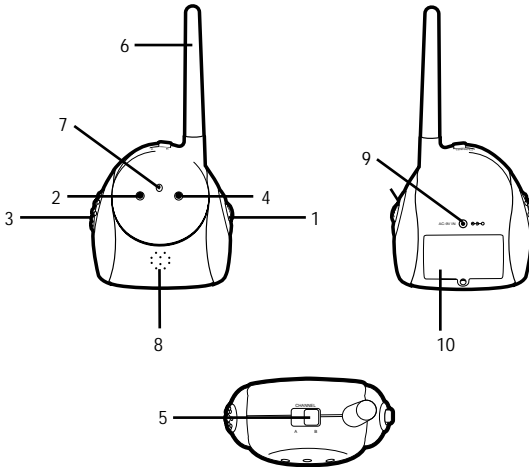

- 1 On/Volume Dial
- 2 Power On (green)/Low Battery (amber) LED Indicator
- 3 Two-Way Activation Button
- 4 Two-Way Mode LED (red) Indicator
- 5 Channel Selector
- 6 Antenna
- 7 Microphone
- 8 Speaker
- 9 AC Adapter Jack
- 10 Battery Compartment Door

## AC Adapters

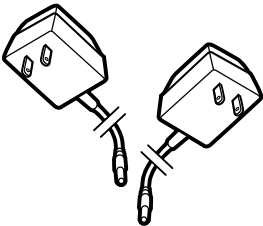

The AC Adapters are low voltage power sources that allow you to use your household electricity to run the Parent's and Baby's Units. They connect to the AC Adapter jacks in the Parent's Unit and in the Baby's Unit, and plug into any standard electrical outlet.

**CAUTION:** These Adapters were made with a specific design for this Safety 1st Two-Way Intercom Monitor. They cannot be used with any other appliance. Never use a different type of Adapter with this monitor.

**! WARNING:** Never touch the end of the adapter cord when the adapter is plugged into an electrical outlet.

# Operating your 49MHz Two-Way Intercom Monitor

Follow these instructions to operate your 49 MHz Two-Way Intercom Monitor. Reference the illustrations on page 4 for the location of all features described in these instructions.

## Baby's Unit:

For best results, place the Baby's Unit on a table near the crib or bed. It should be facing the baby's head as close to the crib as possible, but out of baby's reach.

### To Use Baby's Unit:

**STEP 1** To use household power, plug the round end of adapter cord into the jack on the Baby's Unit, then plug the adapter into an electrical outlet.

**NOTE:** Battery power is available when one 9 volt alkaline battery (not included) is installed in the Baby's Unit. However, it is not recommended to use the battery power for extended periods when household power is available.

**STEP 3** Turn Unit on by using On/Volume Dial. Power On LED should illuminate solid green.

**STEP 4** Set Baby's Unit to channel "A". If you hear interference, switch both Units to channel "B".

**NOTE:** If you experience a power failure, the Baby's Unit **WILL NOT** automatically switch to battery power. You must disconnect the AC Adapter from the Baby's Unit and insure that (1) 9 volt alkaline battery (not included) is installed for battery power.

### To Install Battery (for use in Portable Mode):

(One 9 volt alkaline battery required, not included)

**STEP 1** Locate battery compartment door on bottom of the Baby's Unit as shown in **Figure A**. Using Phillips head screwdriver, remove the screw to take off the battery compartment door.

**STEP 2** Snap 9 volt alkaline battery onto the battery clip, and return to battery compartment as shown in **Figure B**. Replace battery compartment door and secure with Phillips screwdriver, taking care not to over tighten.

**NOTE:** Power On/Low Battery LED Indicator illuminates (amber) when batteries need replacing.

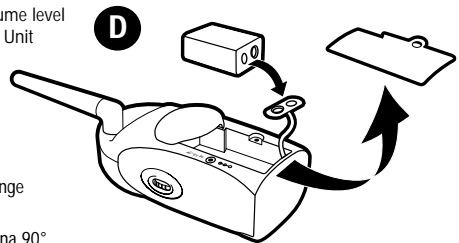
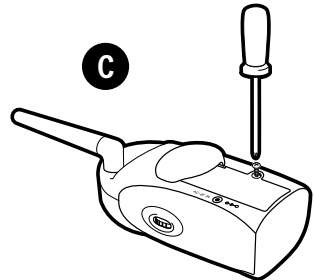
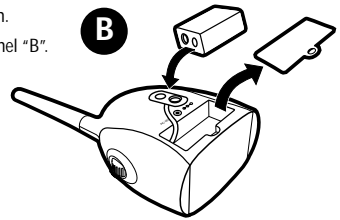
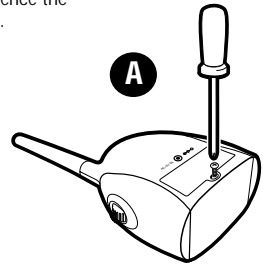

## Parent's Unit

### To Use Parent's Unit:

**STEP 1** To use household power, plug the round end of adapter cord into the AC Adapter Jack on the Parent's Unit, then plug the adapter into an electrical outlet. Turn the On/Volume Dial to "ON" and set at an appropriate volume level to hear baby at all times. The Power On LED Indicator on the Parent's Unit should be illuminated solid green.

**NOTE:** If you experience a power failure, the Parent's Unit **WILL NOT** automatically switch to battery power. You must disconnect the AC Adapter from the Parent's Unit and ensure that one 9 volt alkaline battery (not included) is installed for battery power.

**NOTE:** If you experience static or noise interference, you may need to change channels on both Units.

**STEP 2** To clip over waist band or belt, as shown in **Figure E**, rotate antenna 90°.

### To Install Battery (for use in Portable Mode):

(One 9 volt alkaline battery required, not included)

**STEP 1** Locate battery compartment door on back of the Parent's Unit as shown in **Figure C**. Using Phillips head screwdriver, remove the screw to take off the battery compartment door.

**STEP 2** Snap 9 volt alkaline battery onto the battery clip, and return to battery compartment as shown in **Figure D**. Replace battery compartment door and secure with Phillips screwdriver, taking care not to over tighten.

**NOTE:** Power On/Low Battery LED Indicator illuminates (amber) when batteries need replacing.

**NOTE:** If you experience static or noise interference, you may need to change channels on both Units.



# Intercom Mode

## How to Operate

**STEP 1** Depress Two-Way Activation Button on Baby's Unit. Two-Way Mode LED will illuminate solid red.

**STEP 2** Set volume on Baby's Unit to desired level.

**STEP 3** Press the "Push to Talk" Button on Parent's Unit and speak directly into Microphone. "Push to Talk" Button must be depressed while you speak for Baby's Unit to receive communication.

**Note:** If interference is heard, switch both Units to the other channel.

## Operating Tips

- Make sure both Units are on the same channel. Even though you may hear your baby's sounds, proper use of this system requires that both units be on the same channel. If on different channels, signals from Baby's Unit can be strong enough to be picked by Parent's Unit, however, there will be a lot of static.
- When using AC adapter, make sure electrical outlet has power. Some electrical outlets are powered through a wall switch in the room. When Baby's and Parent's Units are plugged in and turned "ON", the power indicator light should be lit. If it is not, turn wall switch "ON".

## Troubleshooting

Problem	Possible Cause	Solution
<ul style="list-style-type: none"><li>• Power On LED not working</li></ul>	<ul style="list-style-type: none"><li>• Battery may be dead, 9-volt battery needs to be replaced</li><li>• Power is not getting to the unit</li></ul>	<ul style="list-style-type: none"><li>• Replace 9-volt battery</li><li>• Make sure wall outlet is working</li><li>• Make sure unit is properly plugged into the wall and outlet is switched ON</li></ul>
<ul style="list-style-type: none"><li>• Static or interference in the signal transmission</li></ul>	<ul style="list-style-type: none"><li>• Baby's and Parent's Units may be set on different channels</li><li>• Appliances with loud fans near Units may be blocking transmission</li><li>• Local interference from electrical or radio frequency appliance near your location</li></ul>	<ul style="list-style-type: none"><li>• Make sure both Units are on the same channel (A or B)</li><li>• Turn off the appliances that may be causing interference</li><li>• Reduce the distance between the two Units</li><li>• Unit may be under fluorescent lights, turn off lights</li><li>• Switch channel setting on both Parent's and Baby's Units</li></ul>
<ul style="list-style-type: none"><li>• Parent's Unit is making loud noises</li></ul>	<ul style="list-style-type: none"><li>• Units are too close together</li></ul>	<ul style="list-style-type: none"><li>• Parent's Unit needs to be at least 3 meters (10 feet) away from the Baby's Unit</li></ul>
<ul style="list-style-type: none"><li>• Parent's Unit is picking up noises from outside your home</li></ul>	<ul style="list-style-type: none"><li>• Neighbors may have a baby monitor or cordless phone</li></ul>	<ul style="list-style-type: none"><li>• Change both Units to the alternate channel (A or B)</li></ul>
<ul style="list-style-type: none"><li>• Weak sound coming from Unit</li></ul>	<ul style="list-style-type: none"><li>• Batteries may be weak</li><li>• Units may be too far away from each other</li></ul>	<ul style="list-style-type: none"><li>• Check batteries, replace if necessary</li><li>• Move the Units closer</li></ul>
<ul style="list-style-type: none"><li>• Baby's Unit is set for Intercom Mode but not receiving communication from Parent's Unit</li></ul>	<ul style="list-style-type: none"><li>• Parent's "Push to Talk" Button is not being continuously depressed while parent is speaking</li></ul>	<ul style="list-style-type: none"><li>• Continuously hold "Push to Talk" Button while speaking into microphone for Baby's Unit to receive complete communication</li></ul>

# **IMPORTANT!**

**Please do not return this product to the store!  
Your questions and comments are important to us!**

Thank you for purchasing this quality product from Safety 1st. We are confident you will be pleased with its many features and performance. If you are having any problems assembling, installing, or using this product, please call us. We will be very happy to answer any questions that you may have. Many times there is a simple solution to any problem that may occur. Talking to us directly will be convenient and save you time.

**Call our Consumer Relations Department toll-free at (800) 723-3065;  
in Canada call (800) 387-2229  
from 9:00 am to 5:00 pm (EST) Monday – Friday.  
We will gladly answer any and all of your questions about this product.**

# Warranty Information

## ONE (1) YEAR LIMITED WARRANTY

Safety 1st, Inc., warrants to the original owner of this product that the Nursery Monitor is free from defects in materials and workmanship for a period of one (1) year from the date of the original purchase. If this monitor fails to function when used as directed under normal conditions, within the one (1) year period, Safety 1st will either repair or replace the product at our option, free of charge, when it is returned complete and in its original packaging, prepaid postage, and insured to Safety 1st Consumer Relations Department (see appropriate address below). Product must be accompanied by a proof of purchase, either a bill of sale, receipted invoice, or other proof that the monitor is within the warranty period. Safety 1st will bear the cost of repairing or replacing the product and shipping it back to you.

This warranty does not apply to a Nursery Monitor that has been damaged as a result of improper maintenance, accidents, improper voltage supply or other misuse. The warranty is also void if the owner repairs or modifies the product in any way. Safety 1st is not liable for any incidental or consequential damages with regard to this product. The warranty also excludes any liability other than what is stated above. No other warranties are given.

LEGAL RIGHTS VARY FROM STATE TO STATE. SOME STATES DO NOT ALLOW THE EXCLUSION OR LIMITATION OF INCIDENTAL OR CONSEQUENTIAL DAMAGES, SO THE ABOVE LIMITATIONS MAY NOT APPLY TO YOU.

IMPORTANT NOTE: ONLY USE THE ADAPTERS SUPPLIED FOR THIS TWO-WAY INTERCOM MONITOR.  
USE OF OTHER ADAPTERS WILL VOID THIS WARRANTY.

If you have questions or comments, please call our Consumer Relations number.

All Safety 1st products are guaranteed. If you are not completely satisfied, please return with proof of purchase to:

Safety 1st, Inc., 45 Dan Road, Canton, MA 02021 USA 800-723-3065

Safety 1st Home Products Canada Inc., 804 rue Deslauriers, Ville St-Laurent, Quebec H4N 1X1 Canada 800-387-2229

Safety 1st (Europe) Limited, Isopad House, Shenley Road, Borehamwood, Hertfordshire WD61TE UK +44(0)20 8236 0707

Made in CHINA to Safety 1st quality specifications. ©2000 Safety 1st, Inc.

[www.safety1st.com](http://www.safety1st.com)

Styles and colors may vary.

**Safety 1<sup>st</sup>**