

For Your Safety

General safety information for the Dräger PSS® 7000 Series of self-contained breathing apparatus (SCBA):

- ◆ Use of this apparatus requires relevant equipment training; observance of this user instruction (UI); and compliance with national regulations, laws and standards governing the use of respiratory apparatus.
- ◆ Use of this apparatus must be only for the purpose specified in this UI, or as confirmed in writing by Dräger.
- ◆ Only trained and competent personnel should inspect and service the apparatus at specified intervals. Records of inspections and servicing are to be maintained in line with NFPA 1852 – Standard on Selection, Care, and Maintenance of Open-Circuit Self-Contained Breathing Apparatus.
- ◆ Use of the apparatus should be consistent with NFPA 1500 – Standard on Fire Department Occupational Safety and Health Program.
- ◆ The automatic alarm function of the Sentinel 7000 detects movement of the wearer and movement or vibration to which the wearer may be subjected.
- ◆ Do not use any form of chemical marking or paint on the equipment.
- ◆ Dräger recommend that a service contract be obtained from your Dräger branch or agent.
- ◆ Contact Dräger for details of service contracts and training courses.
- ◆ Use only original Dräger spare parts and test equipment for service, repair and maintenance.
- ◆ Notify Dräger if there is component fault or failure.
- ◆ All approved respiratory equipment shall be selected, fitted, used, and maintained in accordance with Mine Safety and Health Administration (MSHA), Occupational Safety and Health Administration (OSHA), and other applicable regulations.

Definitions of Alert Icons

The following alert icons are used throughout this document to provide and highlight areas of the associated text that require a greater awareness by the user. A definition of the meaning of each icon is as follows:

- This icon indicates additional information on how to avoid inconveniences when carrying out the instructions described.
- This icon indicates a potentially hazardous situation which, if not avoided, could result in physical injury to the user, or damage to the product. It may also highlight an alert against unsafe practices.
- This icon indicates a potentially hazardous situation which, if not avoided, could result in death or serious injury to the user.
- This icon indicates an imminently hazardous situation which, if not avoided, could result in death or serious injury to the user.

Warranty and Liability Statements

Terms and conditions of warranty for the Dräger PSS® 7000 Series of SCBA and associated accessories can be found in the original Dräger invoice document, or can be obtained from Dräger on request.

The Dräger guarantee is void if the original sealing caps on the apparatus are tampered with, removed or broken.

Responsibility for the reliable function of the apparatus transfers to the owner or operator when it is serviced or repaired by personnel not authorised by Dräger, or when it is used in a manner not conforming to its intended use.

- This device has been tested and complies with the FCC rules. Changes or modifications not expressly approved by the manufacturer will void your authority to operate this product.

Description and Intended Use

This UI describes the Dräger PSS® 7000 Series of SCBA fitted with the following:

- ◆ A Dräger Sentinel 7000 electronic monitoring system, with integral personal alert safety system (PASS).
- ◆ A Dräger wireless head-up display (HUD) unit.

The Dräger PSS® 7000 is a compact and lightweight apparatus that provides the wearer with respiratory protection when working in contaminated or oxygen-deficient conditions. The system can be used as a self-contained system or with an independent air supply to increase effective operation time. The system is fully compatible with a wide range of compressed-air cylinders, face masks and lung demand regulators (LDRs).

The carrying system has a height-adjustable articulating backplate (6, Fig 1) that provides improved comfort and ease of use, resulting in increased manoeuvrability and reduced fatigue. The carbon-composite backplate incorporates a sliding height-adjustable yoke that has three preset positions. A flexible pivot joint located at the base of the backplate (in line with the hip of the wearer) moves in response to the twisting and bending of the wearer, improving the weight distribution and freedom of movement. The system includes adjustable shoulder straps (2) and waist belt (11).

The Sentinel 7000 electronic monitoring system is a multi-function system that provides continuous monitoring of the SCBA status including remaining cylinder pressure, movement of the wearer, main battery condition, end-of-service time (EOST) and PASS. It provides visual indications of system status and audible and visual alarms in warning conditions. User control and monitoring of the system is through a user interface (1) that incorporates switches, LEDs, a liquid crystal display (LCD) display screen and an alarm sounder. A backlight illuminates the user interface display screen when required. Additional alarm sounders (5), with warning LEDs top and bottom, are mounted on the backplate and operate only during PASS alarms. The operating settings are preset and non-adjustable by the user.

The PASS function of Sentinel 7000 electronic monitoring system is an alarm system that can be activated manually or automatically. The automatic alarm uses a motion sensor to detect movement and activate a pre-alarm and main alarm at timed intervals when no movement is sensed. The manual alarm is activated by a press button on the user interface. A limitation of the PASS is that it detects movement or vibration to which the wearer is subjected.

Power supplies include a main battery located in the backplate, a back-up battery located the pressure module and a HUD battery located in the HUD. The system is switched on by a press button on the user interface or by cylinder pressure felt at a pressure module, with cylinder pressure transmitted to the pressure module through a high-pressure hose (7). At switch on, a self test is performed and then the system adopts the active mode where the PASS function is operational.

All variants utilise the same high-performance, first-stage, regulator (9) fitted with an EOST mechanical whistle (10). The pressure regulator supplies medium-pressure breathing air to a quick-release coupling (4) via a medium-pressure hose (3). Incorporated in the first-stage regulator is a rapid intervention crew universal air connection (RIC UAC) (8). The RIC UAC is a male coupling that allows emergency replenishment of breathing air to the air cylinder while wearer is breathing from apparatus.

A wireless HUD unit (refer to instruction no. 3356234) locates in the face mask and provides visual indications to the wearer of a number of system conditions. Signals from the Sentinel 7000 to the HUD are from a pressure transducer/transmitter incorporated in the pressure module.

Technical Data

High-Pressure Connections

The following SCBA high-pressure (HP) connections are available for compressed air cylinders:

- ◆ 2216 psi connection to CGA 346
- ◆ 4500 psi connection to CGA 347
- ◆ Quick-connect cylinder coupling (2216 psi or 4500 psi).

Power Supplies

- ◆ Main battery – 7.5 V
- ◆ Back-up battery – 3 V
- ◆ Head-up display battery – 3 V.

RIC UAC Connection

- ◆ 2216 psi or 4500 psi male, quick-release coupling with pressure relief valve (PRV).

LDR to Face mask Connection

- ◆ Dräger push-in connector.

Pressure and Flow Details

Medium pressure – 87 psi to 130 psi
Air flow – In excess of 1000 litres/minute
Air flow at 290 psi – In excess of 500 litres/minute.

EOST Alarms

Activation commencement range (mechanical and electronic):

- ◆ 2216 psi cylinder – 600 psi to 510 psi
- ◆ 4500 psi cylinder – 1215 psi to 1035 psi.

General Information

Batteries

- Danger of explosion. Do not change the batteries in an explosive or flammable atmosphere.
- Do not dispose of batteries in a fire. Batteries must be disposed of in line with local regulations.
- Do not attempt to recharge any non-rechargeable battery.

Battery information:

Main battery – 7.5 V (5 x 1.5 V AA alkaline batteries)
Back-up battery – 3 V (CR123 lithium battery)
HUD battery – 3 V (CR123 lithium battery).

Use only the following approved battery types:

Duracell MN1500 (1.5 V)
Energizer LR6 (1.5 V)
Panasonic CR123AL/1BP (3 V).

- Batteries are supplied with the equipment but are not fitted. Dräger recommend that the batteries be removed when the system is not used for long periods as a small amount of discharge still occurs. The normal operating life of the batteries is dependent on usage time, frequency of alarms, backlight illumination and ambient temperature.

- The back-up battery will only supply power when the main battery is disconnected or discharged. When this occurs, the back-up battery will only supply power for HUD functions.

Preparation for Use

Equipment configurations for non-CBRN use are detailed in a NIOSH Approval Table (refer to instruction no. 3356261). Configurations for CBRN use are detailed later in this instruction (refer to CBRN Use).

Installing the Back-Up Battery

- ◆ Orientate the SCBA to access the battery compartment.
- ◆ Unscrew and remove the battery cap (1, Fig 2), using a suitable coin.
- ◆ Insert the battery, +ve terminal end first, into the battery compartment.
- ◆ Refit and secure the battery cap. Do not overtighten.

Installing the Main Battery

- ◆ Orientate the SCBA to access the pressure module (1, Fig 3).
- ◆ Inspect the terminals on the battery and pressure module, and the sealing rim around the battery terminals (all must be clean and undamaged).
- ◆ Locate the two slots in the top of the battery pack (2) on the tabs in the battery housing.
- ◆ Firmly press the battery into position until an audible click is heard, to indicate a secure attachment. The Sentinel 7000 will emit a single tone and will commence the self-check sequence (refer to Sentinel 7000 Self Check).
- ◆ Press and hold the RH and LH buttons of the user interface until the display clears, then immediately release the buttons.

- A battery check is performed during the self-check sequence. If the battery voltage is below a preset voltage the backlight will illuminate; the low battery icon (Fig 4) will be displayed; the Sentinel 7000 will emit a series of tones for approximately four seconds; and then the display will switch off. When this occurs replace the battery.

- To remove the battery insert and press the two pronged key (supplied with the SCBA) into the two slots at the base of the battery. This will open the locking latch allowing the battery to be removed.

Installing the Cylinder

- The following instructions are for a screw-on cylinder coupling. Installation of a quick-connect cylinder coupling is detailed in a separate UI (refer to instruction no. 3356260).

- ◆ Set the carrying-frame backplate to the short (S) position (refer to Adjusting the Backplate Height).
- ◆ Inspect and check the following:
The external thread of the cylinder valve port.
The internal thread of the first-stage regulator handwheel.
The O-ring seal in the pressure connector is in position and not damaged.
The bore to the sintered filter in the HP connector of the first-stage regulator is clean and free from dirt and contamination.
- ◆ Lay the carrying frame horizontal and fully extend the cylinder strap.

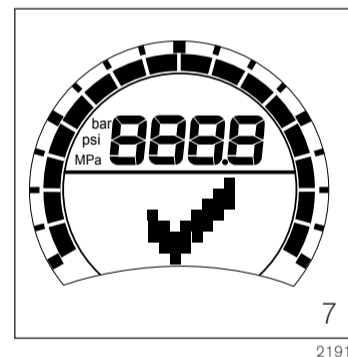
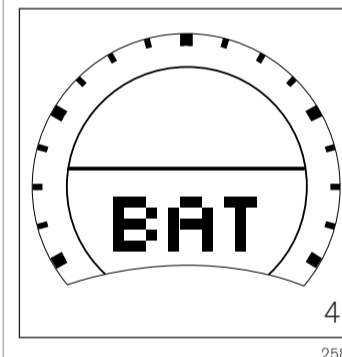
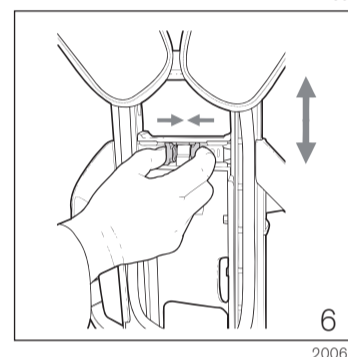
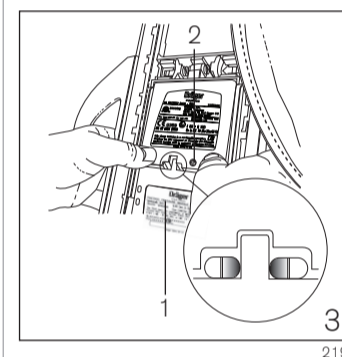
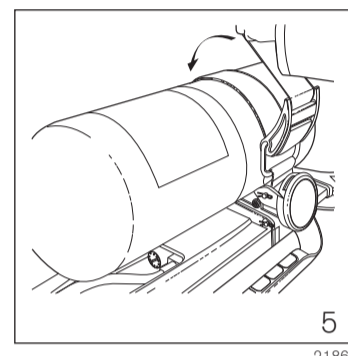
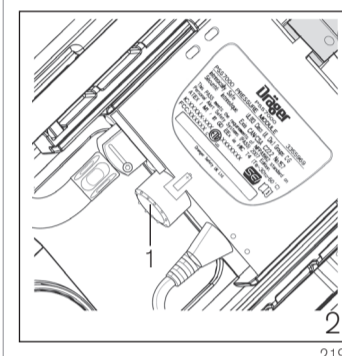
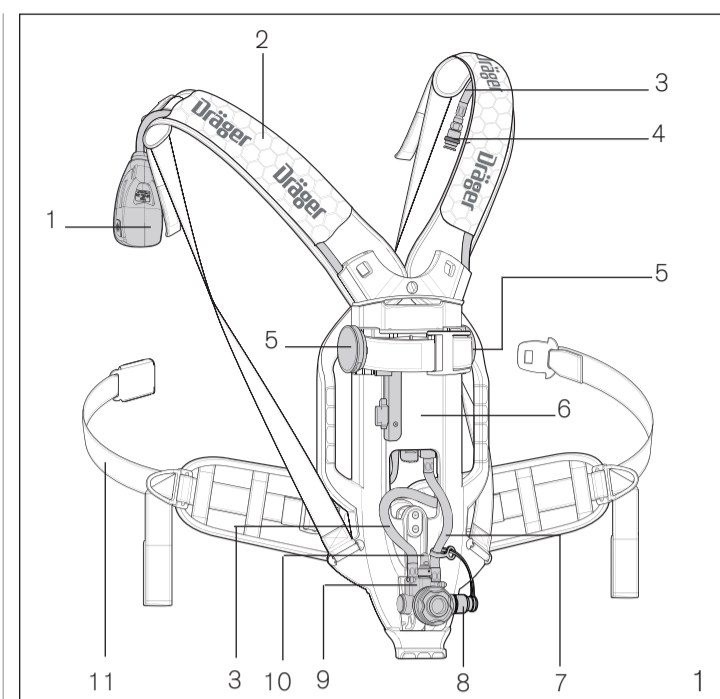

Take care to prevent impact damage as the cylinder valve is aligned with the first-stage regulator handwheel.

- ◆ Insert the cylinder (valve end first) through the cylinder strap, to align the cylinder valve with the handwheel.
- ◆ Lift the cylinder and backplate into the vertical position (supported on the end of the cylinder).
- ◆ Align and fully tighten the handwheel (clockwise). Do not use tools or overtighten.
- ◆ Place the unit back into the horizontal position.
- ◆ Take up the slack of the cylinder strap and activate the cam-lock mechanism by pulling the free end of the strap back over the cylinder (Fig 5).
- ◆ Secure the strap using the Velcro fastening.

Adjusting the Backplate Height

- ◆ Lift the SCBA into the vertical position.
- ◆ Simultaneously press the two spring-loaded buttons (Fig 6) of the locking catch.
- ◆ Slide the yoke to the required position (short (S), medium (M) or long (L)) and release the spring-loaded buttons.
- ◆ Grasp the yoke and the frame and attempt to raise and lower the yoke to confirm that the locking catch is fully engaged.

Connecting the LDR and HUD

- ◆ Insert and push the male coupling of the LDR hose into the quick-release coupling of the SCBA medium-pressure hose until it latches into position. Check the security of the connection (do not connect the LDR to the face mask at this stage).
- ◆ Install a serviceable HUD into the face mask (refer to instruction no. 3356234).

Pre-Operational Checks

Sentinel 7000 Self Check

- The self check can be performed with or without a pressurised cylinder fitted.

Press the LH button of the user interface, or open the cylinder valve of a pressurised cylinder. The following self-check sequence will commence:

- ◆ First stage – The Sentinel 7000 will emit a single tone from the user interface and the additional alarm sounders, and the display backlight will illuminate.
- ◆ Second stage – The display will show a tick symbol (Fig 7); the blue, red and green LEDs (Fig 8) will illuminate.
- ◆ Third stage – The display will show the cylinder type (Fig 9) (2216 psi or 4500 psi).

- ◆ Fourth stage – The display will show the normal operating screen (Fig 10); the blue, red and green LEDs (Fig 8) will illuminate; the blue and red LEDs (1, Fig 11) will illuminate.
- ◆ End of sequence – Two 'trill' alarms will sound; the display will show the normal operating screen (Fig 10); the green LED (Fig 8) will flash at approximately one second intervals to confirm that the Sentinel 7000 has passed the self check and is in the active mode.

NOTICE If a cross icon (Fig 12) with a fault code is displayed, the Sentinel 7000 has failed the self check. Contact Dräger for repair.

- ◆ Press and hold the RH and LH buttons of the user interface until the display clears, then immediately release the buttons.

High-Pressure Leak and EOST Warning Test

NOTICE The following is not intended as a test of HUD functionality. If the HUD fails to operate as described, refer to the HUD UI (instruction no. 3356234).

- ◆ Place the face mask next to the SCBA (within three feet of the pressure module).
- ◆ Press the reset button (1, Fig 13) of the LDR to switch off the positive pressure.
- ◆ Open the cylinder valve slowly, but fully, to pressurise system. The Sentinel 7000 and HUD systems will activate as follows: The Sentinel 7000 will emit a single tone and will commence a self-check sequence (refer to Sentinel 7000 Self Check). Up to approximately 45 seconds after the start of the self check, all six HUD LEDs (Fig 14) will flash twice to indicate that the Sentinel 7000 is communicating with the HUD. Depending on cylinder pressure, some of the line of four HUD LEDs (red/amber/green/green) will flash (on for 15 seconds/off for 45 seconds).
- ◆ Close the cylinder valve and observe the user interface display. The pressure reading shall not decrease more than 200 psi in 1 minute.

NOTICE If the SCBA fails this test, or an immediate leak is evident, do not continue with the check. Vent the pressure, switch off the system and contact Dräger for repair.

- ◆ Cover the outlet of the LDR with the ball of the hand and press the front button (2, Fig 13).
- ◆ Carefully lift the ball of the hand to slowly vent the system – observe the pressure displayed on the user interface.
- ◆ Note the pressures for the electronic EOST activation (indicated by an audible alarm tone; flashing red and blue LEDs on the user interface; flashing red LED on the HUD) and the mechanical whistle operation. Electronic and Mechanical activation does not need to be simultaneous but both must be within the acceptable range (refer to Technical Data – EOST Alarms). Refer to the Service Manual if the pressures are outside the acceptable range.
- ◆ Allow the system to vent to zero pressure. The display will show zero pressure and all of the user interface LEDs (Fig 8) will flash at approximately one second intervals. The green LED indicates that the system is still in active mode.
- ◆ Press and hold the RH and LH buttons of the user interface until the display clears, then immediately release the buttons.
- ◆ The HUD red LED (Fig 14) will flash intermittently.
- ◆ After approximately 180 seconds all six HUD LEDs will flash twice to indicate that the unit has logged off from the Sentinel 7000.
- ◆ Press the reset button of the LDR to switch off the positive pressure.
- ◆ Check that the face mask port and the connector O-ring of the LDR are clean and undamaged.
- ◆ Align and push the LDR into face mask port until it latches in position.
- ◆ Check the attachment by attempting to pull the LDR away from the face mask.

Normal Operation

WARNING All safety information, including the preliminary safety details, must be read and understood before commencing any user task. The procedures detailed in this UI may only be carried out by trained and competent SCBA users.

Before use checks

Carry out a visual inspection of the complete SCBA including any ancillary equipment that will be used during the operation. The tasks detailed in the preparation for use and the pre-operational checks sections must also be completed satisfactorily before release of the SCBA for operational use. Components that are worn or damaged must be repaired or replaced before proceeding. Do not use the equipment if any of the following is found:

- ◆ The SCBA fails to meet any of the test specifications.
- ◆ Any casing is cracked or broken.
- ◆ The LCD display of the user interface cannot be read, or one or more of the display segments is inoperative.
- ◆ Audible and/or visual alarms are not functioning.
- ◆ Any fault icon shown.

Putting on the Apparatus

WARNING This apparatus may only be worn by trained and competent personnel. The user must ensure that any accessories, ancillary equipment, turnout gear and other clothing items do not interfere with the SCBA and do not create a safety hazard.

- ◆ If necessary, adjust the backplate height (refer to Adjust the Backplate Height).
- ◆ Loosen the shoulder straps and waist belt and put on the SCBA.
- ◆ Check that the shoulder pads are not twisted and take the weight of the system on the shoulders by pulling the shoulder straps. Do not fully tighten at this stage.
- ◆ Close the waist belt buckle and pull the ends of the waist belt forward until the strap padding fits securely and comfortably over the hips (Fig 15). Tuck the belt ends behind the hip pads.
- ◆ Pull the shoulder straps until the SCBA rests securely and comfortably on the hips. Do not overtighten. Tuck the strap ends behind the waist belt.
- ◆ Fully loosen the head straps of the face mask and place the neck strap over the back of the neck.
- ◆ Press the reset button (1, Fig 13) of the LDR to switch off the positive pressure.
- ◆ Open the cylinder valve slowly, but fully, to pressurise system. The Sentinel 7000 and HUD systems will activate.

Putting on the Face Mask

WARNING Use only the mask sizes that have been confirmed by a quantitative fit test (QNFT).

- ◆ Select the correct size of mask and inner mask.
- ◆ Put on the face mask (for non-CBRN use, refer to instruction no. 9021649; for CBRN use, refer to instruction no. 3356259).
- ◆ Press the front button (2, Fig 13) of the LDR and check that air flow is delivered into the face mask.
- ◆ Press the reset button (1) to stop the air flow.
- ◆ Close the cylinder valve and breathe normally to empty the system of pressure.

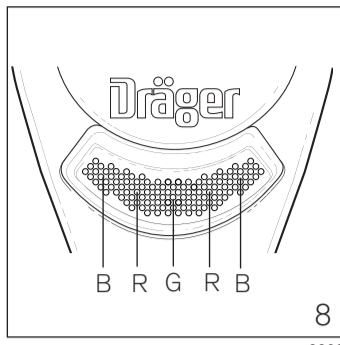

2200

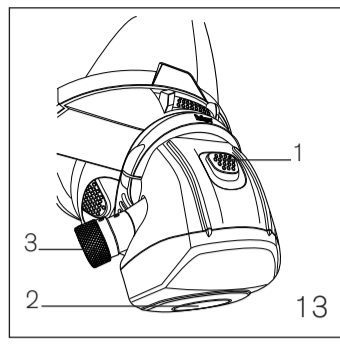

2117

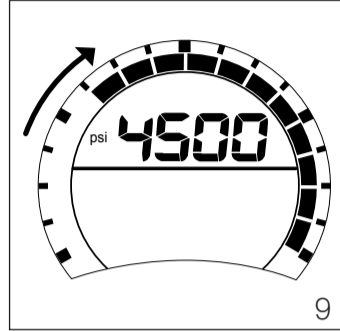

2190

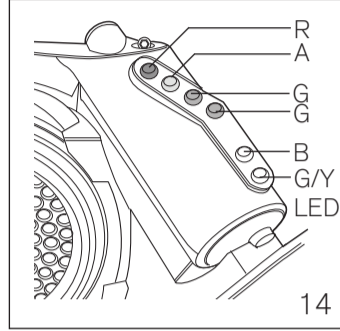

2189

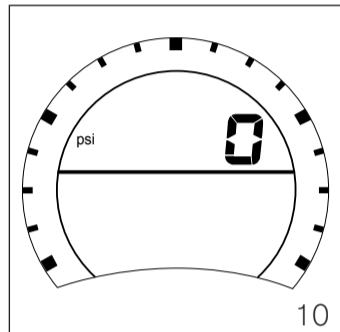

2192

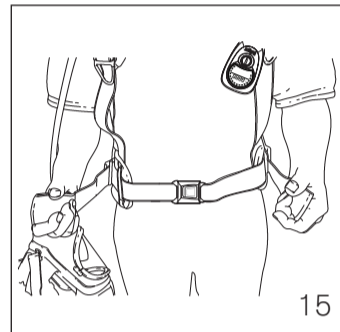

2193

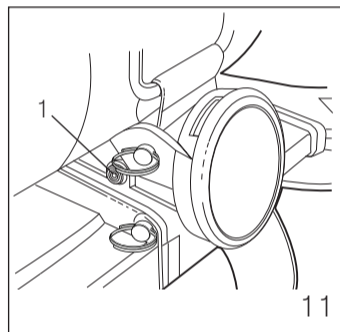

2210

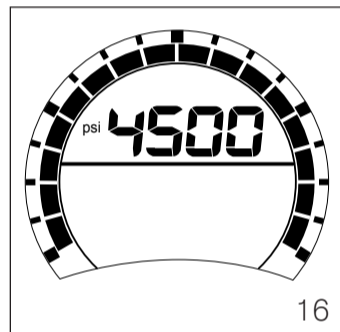

2202

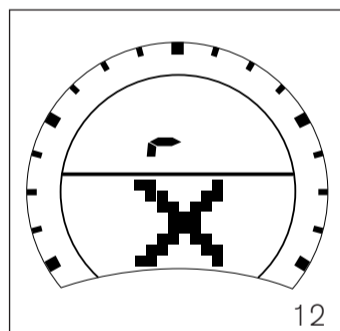

2201

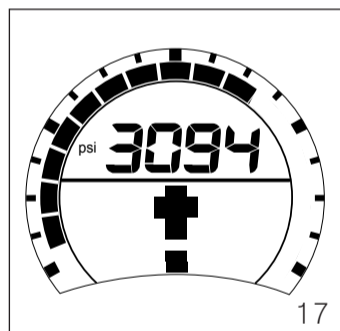

2198

- ◆ When the system is empty, inhale and hold breath for approximately 8 seconds. Readjust and retest until the face mask contracts and holds on to the face with no air leaks.
- ◆ Open the cylinder valve slowly, but fully, to pressurise system.

During Use

WARNING Do not commence any operation (including supplied-air respirator (SAR) operations) using a cylinder that is less than 80% full. The effective working duration of the apparatus is dependent on the capacity of the air cylinder and the breathing rate of the wearer.

NOTICE On activation if the unit fails to operate, or a low battery alarm activates, then the relevant batteries should be renewed.

Regularly observe warning and display signals, and note the following:

- ◆ For emergency help or assistance, press the yellow button in the centre of the user interface to activate the PASS alarm (see below).
- ◆ To illuminate the display backlight, press and release the LH or RH button of the user interface.
- ◆ Remaining cylinder pressure is indicated on the user interface and the HUD LEDs. The user interface shows the cylinder pressure digitally (numeric) and as an analogue segment display (Fig 16). The HUD shows the cylinder pressure with LEDs (refer to the Table 1). The user interface digital display is the most accurate indicator.
- ◆ Remaining time to EOST alarms is indicated on the user interface as a digital (numeric) display.
- ◆ React to the following alarm and warning signals as necessary:
 - EOST – The user interface will emit an audible alarm tone, and red and blue LEDs will flash; the red LED on the HUD will flash; the mechanical whistle on the first-stage regulator will sound.
 - PASS pre-alarm – A repeating audible alarm tone will be emitted from the user interface sounder and the additional alarm sounders. Move the user interface to cancel the alarm (do not attempt to use the buttons to switch off the pre-alarm).
 - PASS alarm – A high-level sweeping alarm will be emitted from the user interface sounder and the additional alarm sounders; red and blue LEDs on the user interface (Fig 8) and top and bottom of the additional alarm sounders (Fig 11) will flash intermittently; the user interface will show the alarm icon (Fig 17). Simultaneously press and hold the RH and LH buttons of the user interface to cancel the alarm.
 - Low main battery – A low battery icon (Fig 4) will be displayed on the user interface or the G/Y battery LED (Fig 14) will flash yellow.
 - Low HUD battery – The G/Y battery LED will flash green.
 - Loss of HUD communication – The HUD blue LED flash
- ◆ Additional air flow can be delivered into the face mask as follows: Press and release the bypass button (3, Fig 13) to deliver a single jet of air into the face mask.

Additional air flow required – Press and rotate the bypass button to deliver a sustained air supply (80 to 130 litres/minute) into the face mask
Excessive or loss of air flow – Close the cylinder valve then immediately begin to slowly reopen the valve. Use the cylinder valve as a regulating valve to set the air flow to meet the user requirement. This procedure can also be used with ratchet-type cylinder valves.

WARNING The air flow procedures above are emergency measures that may greatly reduce the operating duration of the air supply. When activated the user must immediately evacuate to a safe area. The reason for using the procedure must be investigated and repaired before reusing the apparatus.

Table 1 Head-up display LEDs

Cylinder Contents	LEDs			
	R	A	G	G
Full to 3/4	●	●	●	●
3/4 to 1/2	●	●	●	
1/2 (for 20 secs once)	●	★		
1/2 to 1/4	●	●		
1/4 to approx. 100 psi	★			

Key:
● On
★ Flashing
R Red
A Amber
G Green

After Use

WARNING Do not remove the SCBA until in a safe area. Do not drop or throw down the SCBA as damage could occur.

- ◆ Release and loosen all of the face mask straps.
- ◆ Lift and remove the face mask.
- ◆ Fully extend all of the straps of the head harness.
- ◆ Close the cylinder valve.
- ◆ Release the waist belt buckle, lift shoulder strap buckles to loosen and remove the apparatus.
- ◆ Press the front button (2, Fig 13) of the LDR to vent system.
- ◆ Press the reset button (1) to switch off the positive pressure.
- ◆ If the LDR has been set to bypass, press and rotate the bypass button (3) to switch off the bypass.
- ◆ Press and hold the RH and LH buttons of the user interface until the display clears, then immediately release the buttons. After approximately 180 seconds, all six HUD LEDs will flash twice to indicate that the unit has logged off.
- ◆ Carry out a visual inspection of the complete SCBA including any ancillary equipment used during the operation.
- ◆ If required, lightly lubricate the LDR O-ring (recommended lubricant is Molykote 111).
- ◆ Pass the SCBA to the service department, with details of any faults/damage that occurred during use.

Removing the Cylinder

WARNING Do not attempt to remove the cylinder with the system pressurised.

- ◆ Close the cylinder valve and fully vent the system.
- ◆ Lift the free end of the cylinder strap from the Velcro fastening and lift the strap against the cam-lock mechanism to release the strap tension. Loosen the strap.
- ◆ Unscrew the handwheel of the first-stage regulator from cylinder valve.
- ◆ Lift and carefully slide the cylinder away from first-stage regulator towards the top of the backplate.
- ◆ Remove the cylinder from the apparatus.
- ◆ Inspect and recharge the cylinder (refer to Charging the Cylinder).

Charging the Cylinder

WARNING Air quality for compressed air cylinders must conform to the minimum grade requirements for Type 1 gaseous air as defined in the CGA Commodity Specification for Air, G-7.1 (Grade D or higher quality) and where appropriate be in accordance with: NFPA 1989 Standard on Breathing Air Quality for Emergency Services Respiratory Protection.

WARNING Recharge cylinders to the indicated working pressure marked on the cylinder.

WARNING If the moisture content exceeds the recommended levels, ice particles can form, reducing or blocking the airflow.

Cleaning the SCBA

CAUTION Use only recommended cleaning agents. Do not use organic solvents, such as acetone, alcohol, white spirit, trichloroethylene or similar. Do not use any form of mechanical, electrical or ultrasonic agitation in cleaning baths. Refer to manufacturers' instructions when using cleaning and disinfecting agents. Particular attention should be paid to concentration and reaction times.

CAUTION Do not exceed 86 °F for washing and rinsing solutions. Do not exceed 140 °F for drying. Do not immerse the LDR.

NOTICE Recommended cleaning and disinfecting agent is liquid AirKem A-33. Full details of cleaning and disinfecting agents are available from Dräger on request.

- ◆ Carefully clean SCBA components (use suitable cleaning baths, and immerse and manually agitate components in solution as necessary).
- ◆ Thoroughly remove any cleaning solutions by rinsing in clean water.
- ◆ Dry all components, including internal parts.

Storage (Ready for Use)

- ◆ Fully extend the shoulder straps, waist belt and head harness straps.
- ◆ Store apparatus in a cool dry environment, free from dust and dirt (do not expose to direct sunlight).
- ◆ When the SCBA is stored with the cylinder fitted, the apparatus must be supported by the cylinder and not the backplate.
- ◆ Remove the batteries if the equipment is not used for long periods (a small amount of discharge occurs during storage).

Special instructions

Use of an Independent Air Supply (SAR Airline Connection)



Air quality must conform to the statutory requirements.

Use of an airline connection by a second person (buddy-breather) voids NIOSH approval.

The time required for the wearer to escape to a safe area must be within the remaining breathing time of the cylinder, taking into account the remaining air content in the cylinder and the breathing rate of the wearer.

Independent air supplies must meet the following standards:

- ◆ Type-1 gaseous air as defined in: CGA Commodity Specification for Air, G-71 (grade D or higher)
- ◆ NFPA 1989 Standard on Breathing Air Quality for Fire and Emergency Services Respiratory Protection
- ◆ Air supply pressure – 87 psi to 125 psi
- ◆ Airline hose length – 5 feet to 300 feet (maximum working hose length must not exceed 12 individual hose lengths)
- ◆ Airline flow rate – 550 litres/minute
- ◆ Approved for use at temperatures above minus 25 degrees Fahrenheit (minus 31.7 degrees Centigrade).



Sentinel 7000 alarms and warning signals will operate as normal.

The user interface display will show cylinder pressure when the cylinder valve is open.

- ◆ Turn on the independent air supply.
- ◆ Connect the independent air supply coupling to the secondary supply hose (refer to instruction no. 3355853) and breathe normally.
- ◆ Close the cylinder valve (if the EOST warning signal activates, silence by taking several short deep breaths or momentarily operating the LDR bypass button (3, Fig 13).
- ◆ If any air supply problems are encountered, proceed as follows:
Open the cylinder valve to return to breathing from the attached cylinder.
Disconnect the independent air supply coupling.
Leave the hazardous area by the shortest and safest escape route, if necessary.

Cautions and Limitations

- D – Air-line respirators can be used only when the respirators are supplied with respirable air meeting the requirements of CGA G – 7.1, Grade D or higher quality.
- E – Use only the pressure ranges and hose lengths specified in the User's Instructions.
- I – Contains electrical parts that may cause an ignition in flammable or explosive atmospheres.
- J – Failure to properly use and maintain this product could result in injury or death.
- M – All approved respirators shall be selected, fitted, used, and maintained in accordance with MSHA, OSHA, and other applicable regulations.
- N – Never substitute, modify, add, or omit parts. Use only exact replacement parts in the configuration as specified by the manufacturer.
- O – Refer to User's Instructions and/or maintenance manuals for information on use and maintenance of these respirators.
- S – Special or critical User's Instructions and/or specific use limitations apply. Refer to User's Instructions before donning.

CBRN Use

The Dräger PSS® 7000 Series is certified by National Institute for Occupational Safety and Health (NIOSH), for limited chemical, biological, radiological or nuclear (CBRN) use and by the Safety Equipment Institute (SEI) to meet the requirements of NFPA 1981. Approvals are only valid when the apparatus is used with compressed air cylinders approved by NIOSH. Equipment configurations for CBRN use are detailed in a CBRN Approval Label (refer to instruction no. 3356226).

If an FPS NFPA LDR, Dräger recommend that a quantitative fit test (QNFT) be performed on the face mask before use in a CBRN environment. The fit test must be conducted strictly in accordance with the requirements outlined in the OSHA Respiratory Protection Standard 29 CFR, Section 1910.134.

- Q – Use in conjunction with personal protective ensembles that provide appropriate levels of protection against dermal hazards.
- R – Some CBRN agents may not present immediate effects from exposure, but can result in delayed impairment, illness or death.
- T – Direct contact with CBRN agents requires proper handling of the SCBA after each use and between multiple entries during the same use. Decontamination and disposal procedures must be followed. If contaminated with liquid chemical warfare agents, dispose of the SCBA after decontamination.
- U – The respirator should not be used beyond 6 hours after initial exposure to chemical warfare agents to avoid possibility of agent permeation.

S – Special or Critical Users' Instructions

- ◆ Approved for use at temperatures above minus 25 degrees Fahrenheit (minus 31.7 degrees Centigrade).
- ◆ When used as a combination supplied-air respirator/self-contained breathing apparatus (SAR/SCBA), not more than 20 per cent of the air supply can be used during entry.
- ◆ During supplied air use, the cylinder valve must remain closed. If the supplied air fails, open the cylinder valve and immediately proceed to fresh air.
- ◆ Supplied air source must meet the following criteria: pressure 87 – 125 psi, air flow rate at least 550 litres/minute.

Important Note: If it is decided to exit the working area with the airline disconnected or, in an emergency, if the air supply fails, breathe normally and immediately proceed as follows:

- ◆ Open the cylinder valve (counterclockwise) slowly, but fully and breathe normally.
- ◆ Disconnect the hose of the independent air supply from the male coupling of the airline hose connection. Breathe normally and immediately leave the hazardous area by the shortest and safest route.

Safety Warning: The remaining duration begins from the time of opening the cylinder valve and disconnecting the independent air supply. The time required to allow the wearer to escape to a safe area must be within the remaining air capacity (volume) of the cylinder taking into account the breathing rate of the wearer.

RIC UAC Use

- ◆ Use of the RIC UAC should be by trained and competent personnel only.
- ◆ The RIC UAC filling hose is a required component of the NFPA 1981 certification. Only use a filling hose which has been certified to NFPA 1981 for use in immediately dangerous to life or health (IDLH) atmospheres.
- ◆ Do not use the RIC UAC connection for second person (buddy-breather).
- ◆ Do not use the RIC UAC support pack to transfer air from one compressed air breathing apparatus to another.
- ◆ Do not allow oil, grease or other contaminants to contact the RIC UAC connection.
- ◆ Do not attempt to disassemble or repair the RIC UAC connection.
- ◆ **Caution:** The secondary air supply pressure to the RIC UAC must not exceed maximum rated working pressure of the cylinder(s) being filled.
- ◆ **Caution:** If the pressure relief valve of the RIC UAC is activated, the SCBA must be returned to the nearest Dräger branch or agent.
- ◆ **Caution:** If a leak is detected while refilling in a contaminated or oxygen-deficient gaseous atmosphere, stop refilling and immediately leave the hazardous area.

Contact Details

Any issues with the equipment, including damage, malfunction, or failure of the breathing apparatus that may present a hazard to the user should be reported to:

Draeger Safety, Inc.
101 Technology Drive
Pittsburgh
PA15275
Phone: 1-800-922-5518
Fax: 1-800-922-5519

Contact with the certification organisations may be reached at:

NIOSH, NPPTL
Phone: 1-800-232-4636

SEI (NFPA)
1307 Dolley Madison Blvd
Suite 3A, McLean
VA 22101
Phone: 1-703-442-5732

Equipment Maintenance Procedures

Tasks identified in Tables 2 or 3 as maintenance tasks are to be carried out by trained and competent personnel only (authorised by Dräger). Refer to the maintenance manual for further information.

Equipment servicing

Dräger recommend that regular inspection, testing and servicing of equipment be carried out in accordance with Table 2 below. The table applies also to out-of-use (stored) equipment.

Records of inspections and servicing are to be maintained in line with NFPA 1852 – Standard on Selection, Care, and Maintenance of Open-Circuit Self-Contained Breathing Apparatus.

Refer also to the maintenance information for all accessories used (face mask, LDR, HUD, etc.).



Table 2
Equipment servicing

	Description	After Use	Every Month	Every Year
Complete Equipment	Visual inspection	○		
	Clean	○		
	Pre-operational checks	○		
	Flow and static tests (maintenance task)			○
LDR connector O-ring	Check and lubricate if necessary (recommended lubricant is Molykote 111)			○
Back-up battery	Renew			○
First stage regulator	Medium-pressure check (maintenance task)			○
	Renew HP connector O-ring (maintenance task)			○
Cylinder	Charge to correct pressure	○		
	Check the initial test date stamped on the cylinder (composite cylinders over 15 years old must be retired)		○	
	Cylinder pressure test	Carry out in line with national regulations		
Cylinder valve	Basic overhaul	During cylinder pressure test or on condition		

Table 3
Troubleshooting

Symptom	Fault	Remedy
Face mask air leak	O-ring at LDR to facepiece connection Headstraps not tight Exhalation valve leaking Speech diaphragm defective	Renew or lubricate O-ring Tighten Maintenance task Maintenance task
Unsatisfactory communication	Speech diaphragm defective	Maintenance task
High-pressure air leak	Loose connections Faulty or missing hose seals	Maintenance task Maintenance task
Safety relief valve venting	First-stage regulator defective	Maintenance task
LDR allowing constant air flow into the fask mask	Bypass button engaged Internal fault	Turn off the bypass button (3, Fig 13) Maintenance task
Whistle not sounding correctly	Whistle dirty or faulty	Maintenance task
Whistle sounding continuously	Damaged sealing on HP capillary Defective activation mechanism	Maintenance task Maintenance task
Low battery indication on the user interface (Fig 4)	Low main battery	Renew the main battery
Fault code indication on the user interface (Fig 12)	Sentinel 7000 failure	Maintenance task
Sentinel 7000 will not switch on	Low main battery Low cylinder pressure (below 145psi) Unknown	Renew the main battery Recharge cylinder to maximum working pressure Maintenance task
HUD battery LED flashing green	Low battery - HUD	Renew the HUD battery
HUD battery LED flashing yellow	Low main battery	Renew the main battery
HUD will not log on to the Sentinel 7000	HUD not close enough Low HUD battery Low cylinder pressure (below 100 psi) Unknown	Move the HUD to within three feet of the pressure module Renew the HUD battery Recharge cylinder to maximum working pressure Maintenance task