

SMS Projector Mounts

by DRAPER

Specifications—SMS Projector Mounts

SMS Projector Mounts, Model ([Low Profile Fixed] [CL F 80] Adjustable Model [CLV 300-350] [CLV 500-750] [CLV 650-900] [CLV 850-1100] [CLV 1050-1300]), by Draper, Inc., of Spiceland, Indiana.

Universal Projector Bracket: shall be provided for any LCD/DLP projector under 26 lbs, with threaded ceiling-mounting holes. Bracket shall be of steel, with silver finish. Machined steel center column to attach securely to SMS ball joint with twist-lock engagement. Short and long arms interchangeable to fit virtually any projector mounting-hole spacing. Infinite adjustment in both horizontal and vertical axes. Must enable installer to simply find and easily secure projector's center of gravity. Universal Projector Bracket to suspend projector from mount. Clamp/shelf type brackets not acceptable. Hardware for attaching bracket to projector provided by Draper—a full set of screws, washers, vertical spacers, and short and long arms to fit virtually any projector model. Universal bracket shall be compatible with all SMS Mounts for LCD/DLP Projectors.

Adjustable Mount Model (CLV 300-350/CLV 500-750/CLV 650-900/CLV 850-1100/CLV 1050-1300): Ceiling mount shall consist of a 2-piece telescoping column and Universal Projector Bracket. Column shall be of extruded aluminum, with a silver finish. Outer column shall securely attach to ceiling, or above ceiling, with steel ceiling plate (provided). Installer shall provide mounting hardware appropriate to ceiling conditions. Outer column shall have $\pm 30^\circ$ pitch adjustment at the ceiling bracket. Outer column shall have two built-in self-concealing cable races with molded press fit covers. Inner column shall have infinite height adjustability within range according to column size. Setscrew shall be used to lock column in position. Inner column shall have steel ball joint to which the Universal Projector Bracket attaches with twist-lock engagement. Inner column shall be equipped with positive safety stop to prevent separation from outer column. Mount shall have up to 30° roll or pitch adjustment and 360° yaw adjustment at ball joint. Two setscrews shall be used to lock ball joint in position. Maximum load shall be 26 lbs.

CL F 80: Ceiling mount shall consist of a fixed column and SMS Universal Projector Bracket. Column shall be of extruded aluminum, with a silver finish, and shall be $3\frac{1}{8}$ " long. Column shall securely attach to ceiling, or above ceiling, with steel ceiling plate (provided). Installer shall provide mounting hardware appropriate to ceiling conditions. Column shall have steel ball joint to which the Universal Projector Bracket attaches with twist-lock engagement. Min. overall height of assembled unit shall be 6". Mount shall provide up to 30° roll or pitch adjustment and 360° yaw adjustment at ball joint. Two setscrews shall be used to lock ball joint in position. Maximum load to be 26 lbs.

Low Profile Mount: Ceiling mount shall consist of a steel ball joint and SMS Universal Projector Bracket. Mount shall be 2" long, and shall securely attach to ceiling with steel mounting plate (provided). Installer shall provide mounting hardware appropriate to ceiling conditions. Steel ball joint attaches to the Universal Projector Bracket with twist-lock engagement. Min. overall height of assembled unit shall be $4\frac{7}{8}$ ". Mount shall provide up to 30° roll or pitch adjustment and 360° yaw adjustment at ball joint. Two setscrews lock ball joint in position. Silver finish. Maximum load to be 26 lbs.

Projector Manufacturer and Model Number:

Please Mark Appropriate Selections

- SMS Low Profile Fixed Mount
- SMS CL F 80 Fixed Mount
- SMS Adjustable Mount

Select Size Range:

- CLV 300-350 CLV 500-750 CLV 650-900
- CLV 850-1100 CLV 1050-1300

Options

- Security Lock Kit
- Inner Column Trim Clips (grey)
- Outer Column Trim Ring (white)

Model	Range of Adjustability*	Qty.
CLV 300-350	$13\frac{3}{8}$ "- $15\frac{3}{8}$ "	
CLV 500-750	$21\frac{1}{4}$ "- $31\frac{1}{8}$ "	
CLV 650-900	$27\frac{1}{4}$ "- 37 "	
CLV 850-1100	$35\frac{1}{8}$ "- $44\frac{7}{8}$ "	
CLV 1050-1300	43 "- $52\frac{7}{8}$ "	

* Note: Low Profile and SMS Projector CL F 80 height not adjustable



Ceiling Plate Dimensions

CLV 300-350/CLV 500-750/CLV 650-900/CLV 850-1100/CLV 1050-1300

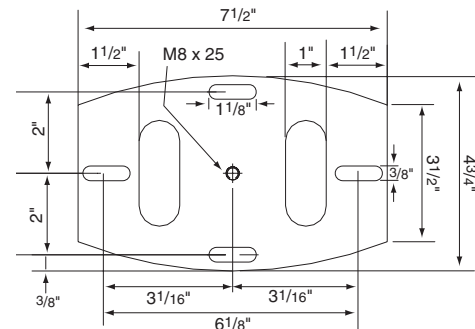

SMS Projector CL F 80

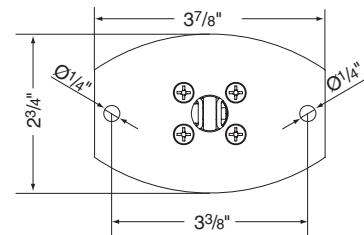

SMS Low Profile

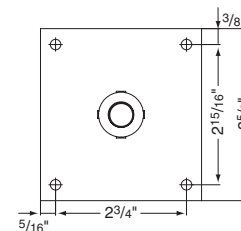

DRAPER

411 S. Pearl St., Spiceland, IN 47385 USA ■ 765-987-7999
www.draperinc.com ■ fax 765-987-7142

Copyright © 2007 Draper Inc. Form SMSProjectorMounts_Sub07 Printed in U.S.A.

PROJECT:	_____
ARCHITECT:	_____
CONTRACTOR:	_____
SUPPLIER:	_____
DATE:	_____
REVISED:	_____

Fixed Mount Dimensions

CL F 80

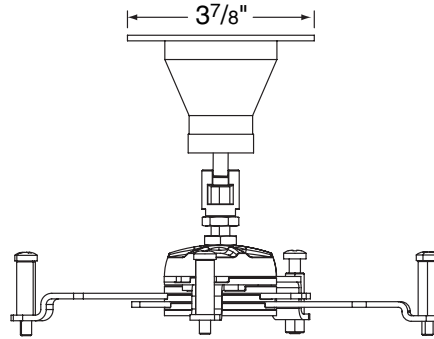
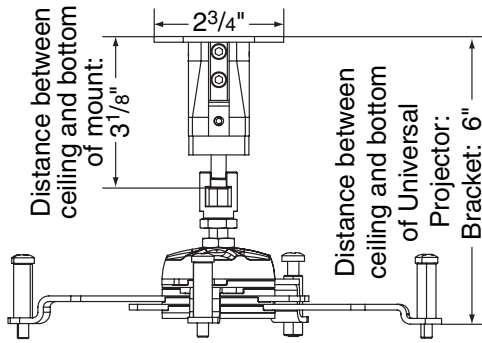

Adjustable Mount Dimensions

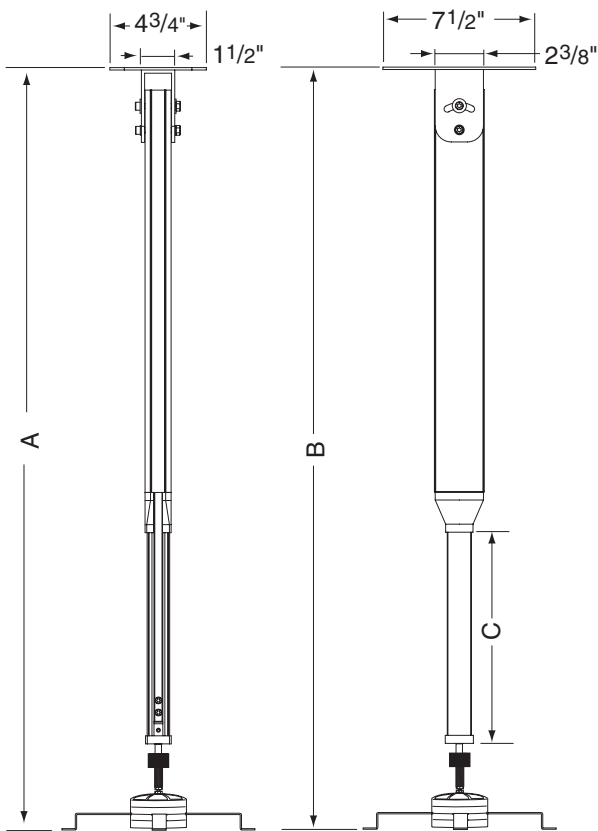

Low Profile

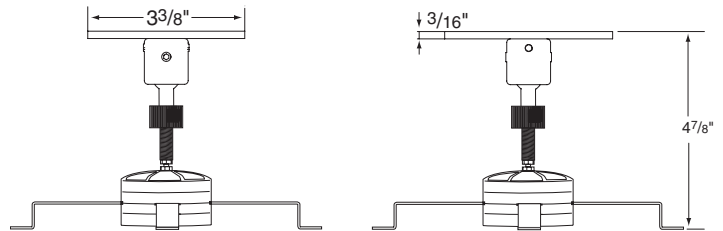

Adjustability	Pitch	Roll	Yaw
At Ceiling Plate	±30°	0°	0°
At Ball Joint	±30°	±30°	360°

Universal Projector Bracket Dimensions

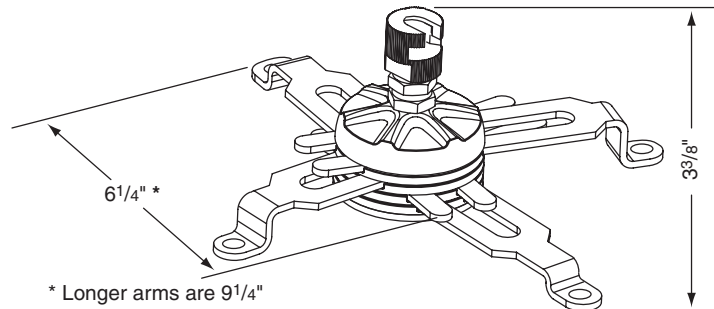

Please Note: This is total height of Universal Projector Bracket. Once attached, Universal Bracket actually adds a minimum of 3" to overall mount size.

Universal Projector Bracket Coverage

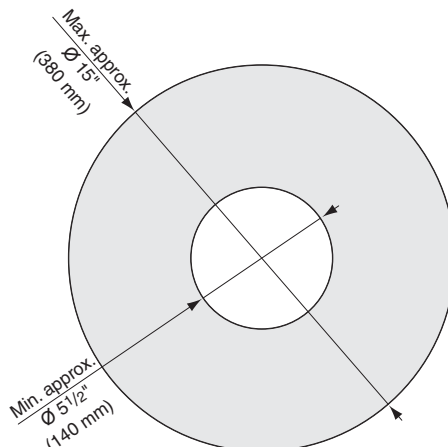

Model	A (Min)	B (Max)	C
CLV 300-350	13 ³ / ₈ "	15 ³ / ₈ "	2"
CLV 500-750	21 ¹ / ₄ "	31 ¹ / ₈ "	9 ⁷ / ₈ "
CLV 650-900	27 ¹ / ₄ "	37"	9 ⁷ / ₈ "
CLV 850-1100	35 ¹ / ₈ "	44 ⁷ / ₈ "	9 ⁷ / ₈ "
CLV 1050-1300	43"	52 ⁷ / ₈ "	9 ⁷ / ₈ "