

# DrayTek

## VigorAP 902

802.11ac Access Point



### Quick Start Guide

V1.0

# VigorAP 902

## 802.11ac Access Point

### Quick Start Guide

Version: 1.0

F/W: V1.1.5\_RC3

Date: November 27, 2015

#### Warranty

We warrant to the original end user (purchaser) that the access point will be free from any defects in workmanship or materials for a period of one (1) year from the date of purchase from the dealer. Please keep your purchase receipt in a safe place as it serves as proof of date of purchase. During the warranty period, and upon proof of purchase, should the product have indications of failure due to faulty workmanship and/or materials, we will, at our discretion, repair or replace the defective products or components, without charge for either parts or labor, to whatever extent we deem necessary to restore the product to proper operating condition. Any replacement will consist of a new or re-manufactured functionally equivalent product of equal value, and will be offered solely at our discretion. This warranty will not apply if the product is modified, misused, tampered with, damaged by an act of God, or subjected to abnormal working conditions. The warranty does not cover the bundled or licensed software of other vendors. Defects which do not significantly affect the usability of the product will not be covered by the warranty. We reserve the right to revise the manual and online documentation and to make changes from time to time in the contents hereof without obligation to notify any person of such revision or changes.

#### European Community Declarations

Manufacturer: DrayTek Corp.

Address: No. 26, Fu Shing Road, HuKou Township, HsinChu Industrial Park, Hsin-Chu, Taiwan 303

Product: VigorAP 902

DrayTek Corp. declares that VigorAP 902 is in compliance with the following essential requirements and other relevant provisions of R&TTE Directive 1999/5/EEC, ErP 2009/125/EC and RoHS 2011/65/EU.

The product conforms to the requirements of Electro-Magnetic Compatibility (EMC) Directive 2004/108/EC by complying with the requirements set forth in EN55022/Class B and EN55024/Class B.

The product conforms to the requirements of Low Voltage (LVD) Directive 2006/95/EC by complying with the requirements set forth in EN60950-1. This product is designed for 2.4GHz/5GHz WLAN network throughout the EC region.

#### Federal Communication Commission Interference Statement

This equipment has been tested and found to comply with the limits for a Class B digital device, pursuant to Part 15 of the FCC Rules. These limits are designed to provide reasonable protection against harmful interference in a residential installation. This equipment generates, uses and can radiate radio frequency energy and, if not installed and used in accordance with the instructions, may cause harmful interference to radio communications. However, there is no guarantee that interference will not occur in a particular installation. If this equipment does cause harmful interference to radio or television reception, which can be determined by turning the equipment off and on, the user is encouraged to try to correct the interference by one of the following measures:

- Reorient or relocate the receiving antenna.
- Increase the separation between the equipment and receiver.
- Connect the equipment into an outlet on a circuit different from that to which the receiver is connected.
- Consult the dealer or an experienced radio/TV technician for help.

This device complies with Part 15 of the FCC Rules. Operation is subject to the following two conditions:

- (1) This device may not cause harmful interference, and
- (2) This device may accept any interference received, including interference that may cause undesired operation.

THE GRANTEE IS NOT RESPONSIBLE FOR ANY CHANGES OR MODIFICATIONS NOT EXPRESSLY APPROVED BY THE PARTY RESPONSIBLE FOR COMPLIANCE. SUCH MODIFICATIONS COULD VOID THE USER'S AUTHORITY TO OPERATE THE EQUIPMENT

You are cautioned that changes or modifications not expressly approved by the party responsible for compliance could void your authority to operate the equipment.



The antenna/transmitter should be kept at least 20 cm away from human body.

**Warning: To prevent damage from overheating, keep the machine erect upright.**

# 1

## Package Content

Take a look at the package content. If there is anything missed or damaged, please contact DrayTek or dealer immediately.



Access Point

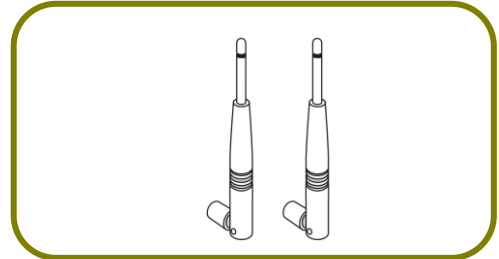

Antenna

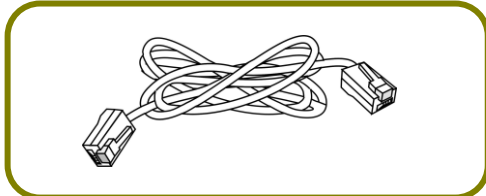

RJ-45 Cable (Ethernet)

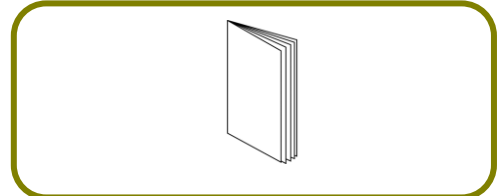

Quick Start Guide

The type of the power adapter depends on the country that the AP will be installed:

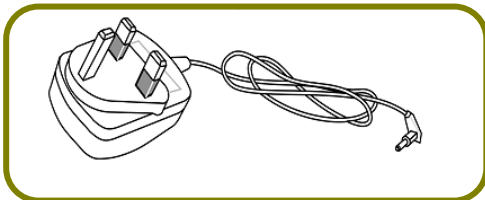

UK-type power adapter

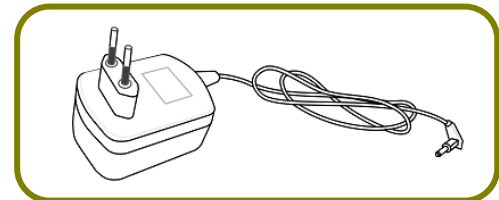

EU-type power adapter

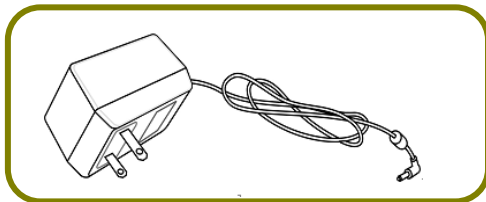

USA/Taiwan-type power adapter

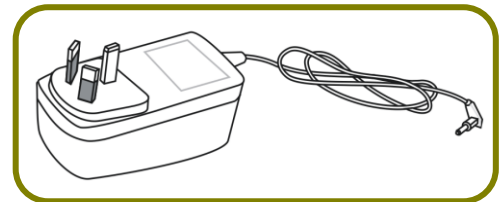

AU/NZ-type Power Adapter



### Note

The antenna/transmitter should be kept at least 20 cm away from human body.

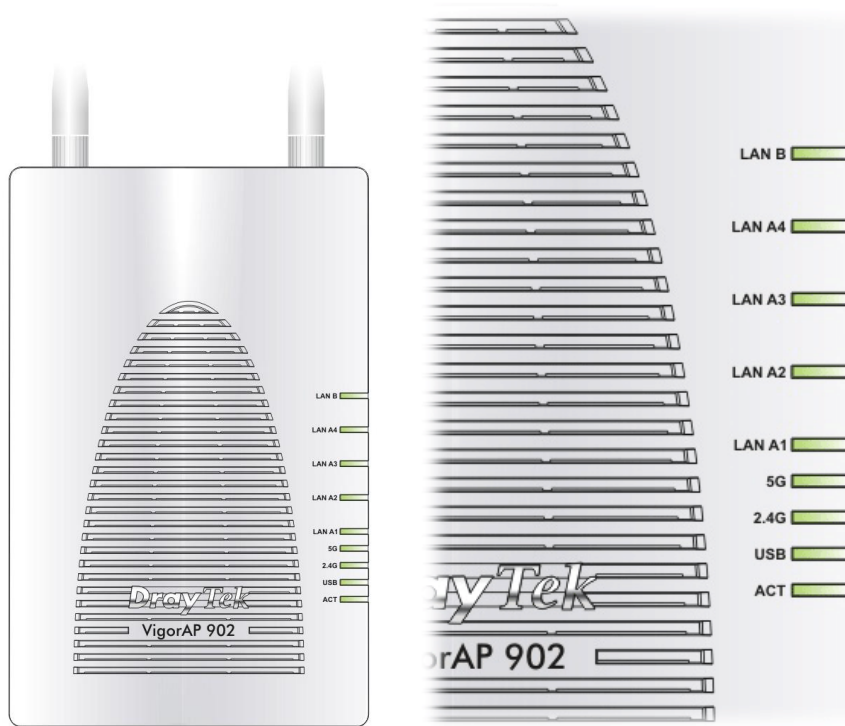

# 2

## Descriptions of Components

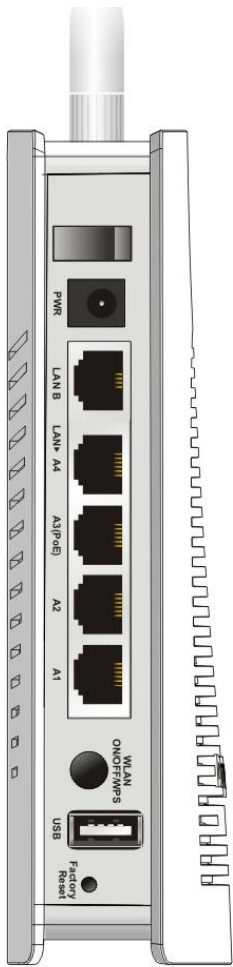

LED	Status	Explanation
ACT	Off	The system is not ready or is failed.
	Blinking	The system is ready and can work normally.
USB	On	A USB device is connected and active.
	Blinking	The data is transmitting.
2.4G	On	Wireless function is ready.
	Off	Wireless function is not ready.
	Blinking	Data is transmitting (sending/receiving).
5G	On	Wireless function is ready.
	Off	Wireless function is not ready.
	Blinking	Data is transmitting (sending/receiving).
LAN A1 - A4	On	A normal connection (rate with 100M/1000M) is through its corresponding port.
	Off	LAN is disconnected.
	Blinking	Data is transmitting (sending/receiving).
LAN B	On	A normal connection (rate with 100M/1000M) is through its corresponding port.
	Off	LAN is disconnected.
	Blinking	Data is transmitting (sending/receiving).



Interface	Description
0/1	Power switch.
	PWR: Connector for a power adapter.
LAN B	Connector for xDSL / Cable modem (Giga level) or router.
LAN A4, A2, A1 A3 (PoE)	Connector for xDSL / Cable modem (Giga level) / computer or router. LAN A3 is used for PoE connection (for indoor use).
 WLAN ON/OFF WPS	Wireless band will be switched /changed according to the button pressed and released. For example, <ul style="list-style-type: none"> <li>● 2.4G (On) and 5G (On) – in default.</li> <li>● 2.4G (Off) and 5G (On) – pressed and released the button once.</li> <li>● 2.4G (On) and 5G (Off) – pressed and released the button twice.</li> <li>● 2.4G (Off) and 5G (Off) – pressed and released the button three times.</li> </ul> WPS - When WPS function is enabled by web user interface, press this button for more than 2 seconds. The router will wait for any wireless client connecting to it through WPS.
USB	Connector for a USB device (for temperature sensor).
	Restore the default settings. Usage: Turn on the router. Press the button and keep for more than 10 seconds. Then the router will restart with the factory default configuration.



### Note

For the sake of security, make the accessory kit away from children.

# 3

## Installation

This section will guide you to install the AP through hardware connection and configure the settings through web browser.

Before starting to configure the router, you have to connect your devices correctly.

1. Connect VigorAP 902 to xDSL modem, router, or switch/hub in your network through the **LAN A** port of the access point by Ethernet cable.



### Note

You can also connect VigorAP 902 to a Vigor router via wireless connection. For detailed information, refer to VigorAP 902 User's Guide.

2. Connect a computer to other available LAN A port. Make sure the subnet IP address of the PC is the same as VigorAP 902 management IP, e.g., **192.168.1.X**.
3. Connect the A/C power adapter to the wall socket, and then connect it to the PWR connector of the access point.
4. Power on VigorAP 902.
5. Check all LEDs on the front panel. **ACT** LED should blink, **LAN** LEDs should be on if the access point is correctly connected to the xDSL modem, router or switch/hub.

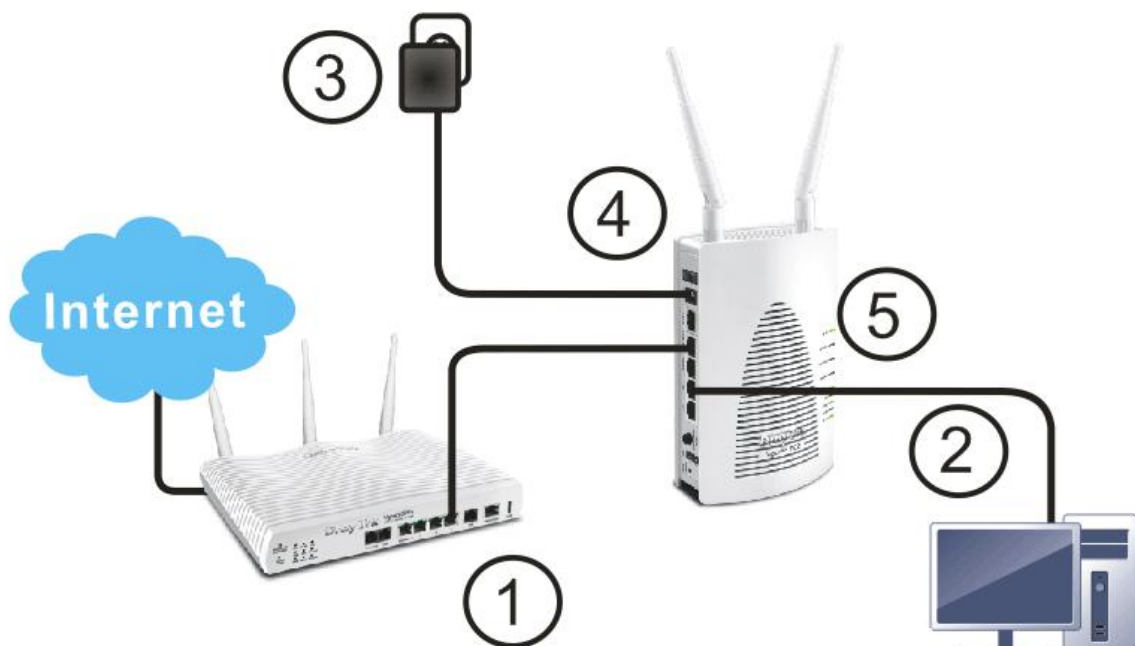

# 4

## Configuring Web Pages

1. Make sure your PC connects to the router correctly.
2. Open a web browser on your PC and type **http://192.168.1.2**. A pop-up window will open to ask for username and password. Please type “admin/admin” on Username/Password and click **Login**.

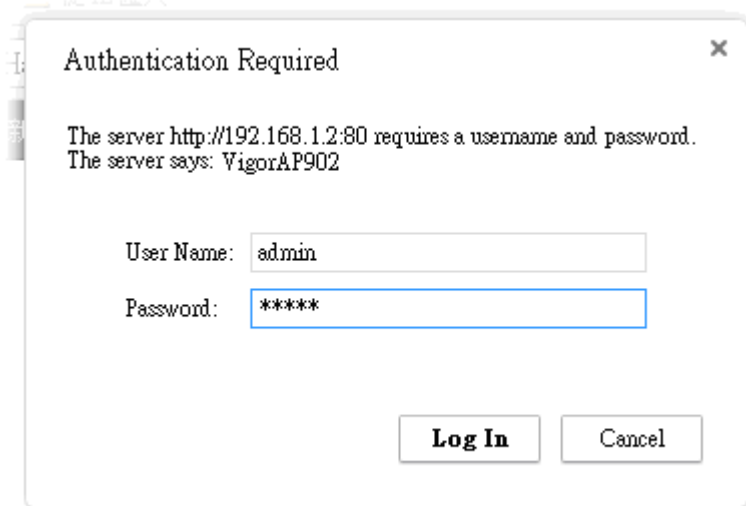

Authentication Required

The server http://192.168.1.2:80 requires a username and password.  
The server says: VigorAP902

User Name:

Password:

3. The **Main Screen** will pop up. Click **Quick Start Wizard**.

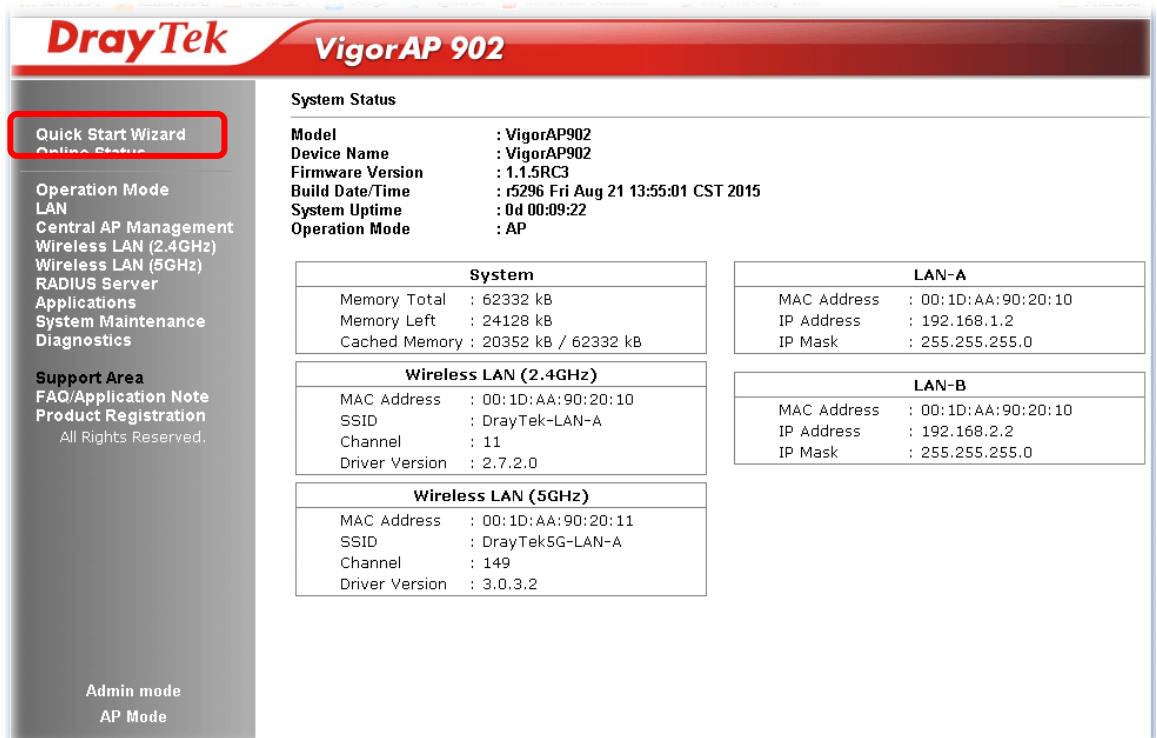

**DrayTek VigorAP 902**

**System Status**

**Model** : VigorAP902  
**Device Name** : VigorAP902  
**Firmware Version** : 1.1.5RC3  
**Build Date/Time** : r5296 Fri Aug 21 13:55:01 CST 2015  
**System Uptime** : 0d 00:09:22  
**Operation Mode** : AP

System	
Memory Total	: 62332 kB
Memory Left	: 24128 kB
Cached Memory	: 20352 kB / 62332 kB

LAN-A	
MAC Address	: 00:1D:AA:90:20:10
IP Address	: 192.168.1.2
IP Mask	: 255.255.255.0

Wireless LAN (2.4GHz)	
MAC Address	: 00:1D:AA:90:20:10
SSID	: DrayTek-LAN-A
Channel	: 11
Driver Version	: 2.7.2.0

Wireless LAN (5GHz)	
MAC Address	: 00:1D:AA:90:20:11
SSID	: DrayTek5G-LAN-A
Channel	: 149
Driver Version	: 3.0.3.2

LAN-B	
MAC Address	: 00:1D:AA:90:20:10
IP Address	: 192.168.2.2
IP Mask	: 255.255.255.0

Admin mode  
AP Mode

**Quick Start Wizard**  
Online Status

Operation Mode  
LAN  
Central AP Management  
Wireless LAN (2.4GHz)  
Wireless LAN (5GHz)  
RADIUS Server  
Applications  
System Maintenance  
Diagnostics

Support Area  
FAQ/Application Note  
Product Registration  
All Rights Reserved.

4. The first page is set for 2.4G wireless connection. There are five operation modes for you to choose. Simply click any one of modes. In this example, choose **AP** and click **Next**.

Quick Start Wizard >> Wireless LAN (2.4GHz)

Operation Mode :    
Wireless Mode :    
Main SSID :    Enable 2 Subnet (Simulate 2 APs)  
Channel :    
Extension Channel :    
Station List :

Wireless(2.4GHz) Security(2.4GHz) Wireless(5GHz) Security(5GHz)

5. For the SSID configuration, choose the mode you want and type related information for client authentication. Then, click **Next**.

Quick Start Wizard >> 2.4G Security

SSID 1	SSID 2	SSID 3	SSID 4
<b>SSID</b> DrayTek-LAN-A			
<b>Wireless Security Settings</b>			
Mode	<input type="text" value="Mixed(WPA+WPA2)/PSK"/> <input type="button" value="v"/>		
WPA Algorithms	<input type="radio"/> TKIP <input type="radio"/> AES <input checked="" type="radio"/> TKIP/AES		
Pass Phrase	<input type="text" value="....."/>		
Key Renewal Interval	<input type="text" value="3600"/>	seconds	
PMK Cache Period	<input type="text" value="10"/>	minutes	
Pre-Authentication	<input checked="" type="radio"/> Disable <input type="radio"/> Enable		

Wireless(2.4GHz) Security(2.4GHz) Wireless(5GHz) Security(5GHz)



- Next, the following page is set for 5G wireless connection. There are three wireless modes for you to choose. The default is Mixed(11a+11n+11ac). Change the information listed in this page according to the data offered by your ISP. Then click **Next**.

Quick Start Wizard >> Wireless LAN (5GHz)

**Operation Mode :**  VigorAP acts as a bridge between wireless devices and wired Ethernet network, and exchanges data between them.

**Wireless Mode :**

**Main SSID :**

**Channel :**

**Extension Channel :**

**Station List :**

---

Wireless(2.4GHz)      Security(2.4GHz)      Wireless(5GHz)      Security(5GHz)

- For the SSID configuration, choose the mode you want and type related information for client authentication. Then, click **Next**.

Quick Start Wizard >> 5G Security

SSID 1	SSID 2	SSID 3	SSID 4
<b>SSID</b>			
DrayTek5G-LAN-A			
<b>Wireless Security Settings</b>			
Mode	<input type="text" value="Mixed(WPA+WPA2)/PSK"/>		
WPA Algorithms	<input type="radio"/> TKIP <input type="radio"/> AES <input checked="" type="radio"/> TKIP/AES		
Pass Phrase	<input type="text" value="....."/>		
Key Renewal Interval	<input type="text" value="3600"/>	seconds	
PMK Cache Period	<input type="text" value="10"/>	minutes	
Pre-Authentication	<input checked="" type="radio"/> Disable <input type="radio"/> Enable		

---

Wireless(2.4GHz)      Security(2.4GHz)      Wireless(5GHz)      Security(5GHz)

Default Pre-Shared Key (PSK) with 13 ASCII characters is provided and stated on the label pasted on the bottom of VigorAP.

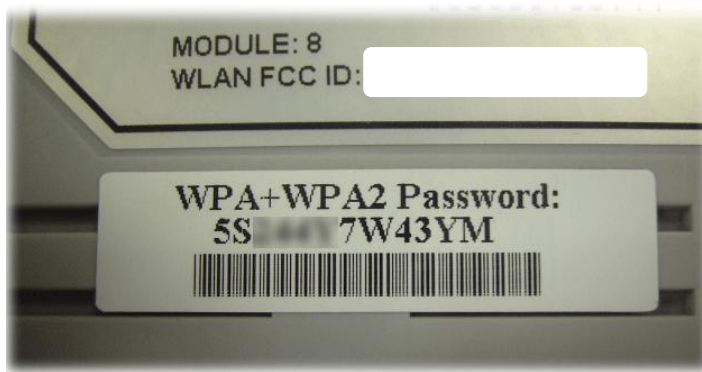

---

**Note**

For the communication, all wireless devices must support the same encryption bit length and share the same key. If WEP mode is selected, only one of four preset keys can be selected at one time.

---

8. In the next page, click **Finish**. The system will make a connection automatically. Open **Online Status** to see the result of network connection.

**Quick Start Wizard**

---

**Vigor Wizard Setup is now finished!**

Basic Settings for VigorAP is completed.

Press Finish button to save and finish the wizard setup.

Note that the configuration process takes a few seconds to complete.

< Back

Finish

Cancel



---

**Note**

Under System Maintenance you can change the access point's default admin password. You should do this immediately in order to prevent users from accessing the VigorAP's management interface and changing settings.

---

## Contacting DrayTek

If the router still cannot work correctly after trying many efforts, please contact your dealer for further help right away. For any questions, please feel free to send e-mail to [support@draytek.com](mailto:support@draytek.com).

### **Safety**

### **Instructions**

- Read the installation guide thoroughly before you set up the access point.
- The access point is a complicated electronic unit that may be repaired only by authorized and qualified personnel. Do not try to open or repair the modem yourself.
- Do not place the access point in a damp or humid place, e.g. a bathroom.
- The access point should be used in a sheltered area, within a temperature range of +5 to +40 Celsius.
- Do not expose the access point to direct sunlight or other heat sources. The housing and electronic components may be damaged by direct sunlight or heat sources.
- Do not deploy the cable for LAN connection outdoor to prevent electronic shock hazards.
- Keep the package out of reach of children.
- When you want to dispose of the access point, please follow local regulations on conservation of the environment.