

DrayTek

VigorAP 920R Series



Quick Start Guide

V1.0

VigorAP 920R Series

Outdoor Extreme Power Wireless AP

Quick Start Guide

Version: 1.0

F/W: V1.2.0_RC1b

Date: February 12, 2017

Warranty

We warrant to the original end user (purchaser) that the access point will be free from any defects in workmanship or materials for a period of two (2) years from the date of purchase from the dealer. Please keep your purchase receipt in a safe place as it serves as proof of date of purchase. During the warranty period, and upon proof of purchase, should the product have indications of failure due to faulty workmanship and/or materials, we will, at our discretion, repair or replace the defective products or components, without charge for either parts or labor, to whatever extent we deem necessary to restore the product to proper operating condition. Any replacement will consist of a new or re-manufactured functionally equivalent product of equal value, and will be offered solely at our discretion. This warranty will not apply if the product is modified, misused, tampered with, damaged by an act of God, or subjected to abnormal working conditions. The warranty does not cover the bundled or licensed software of other vendors. Defects which do not significantly affect the usability of the product will not be covered by the warranty. We reserve the right to revise the manual and online documentation and to make changes from time to time in the contents hereof without obligation to notify any person of such revision or changes.



Declaration of Conformity

Hereby, DrayTek Corporation declares that the radio equipment type VigorAP 920R is in compliance with Directive 2014/53/EU.

The full text of the EU Declaration of Conformity is available at the following internet address:

http://www.draytek.com.tw/ftp/VigorAP_920R/Document/CE/

Manufacturer: DrayTek Corp.
Address: No. 26, Fu Shing Road, HuKou Township, HsinChu Industrial Park, Hsin-Chu, Taiwan 303
Product: VigorAP 920R/920RP

Frequency Information for Europe area:

2.4G WLAN	2412MHz - 2472 MHz, max. TX power: 19.5dBm
5G WLAN	5470MHz - 5725 MHz, max. TX power: 28.0dBm
	Requirements in AT/BE/BG/CZ/DZ/DK/EE/FR/DE/IS/IE/IT/EL/ES/ CY/LV/LI/LT/ LU/HU/MT/ NL/NO/PL/PT/RO/SI/SK/TR/FI/SE/CH/ UK/HR. 5150MHz~5350MHz is for indoor use only.

This product is designed for 2.4GHz/5GHz WLAN network throughout the EC region.



Information

Frequency Information for FCC area:

2.4G WLAN	2412MHz - 2462 MHz, max. TX power: 29.67dBm
5G WLAN	5180MHz - 5240MHz ,5745MHz - 5825MHz, max. TX power: 22.01dBm

Equipment must be professional equipment

Professionals must undergo special training and authorization

The manufacturer must provide the installation instructions to authorized personnel and follow the professional installation instructions.

The installation process must be properly installed with the correct power / cable / antenna configuration.

1

Package Content

Please inspect the package contents. If anything is missing or damaged, please contact DrayTek or your dealer immediately.



Main Unit

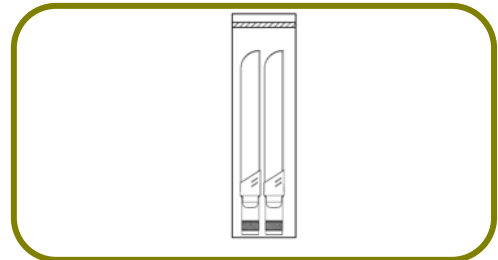

Antennas



Ethernet Cable (3M)



Quick Start Guide



Ground Cable

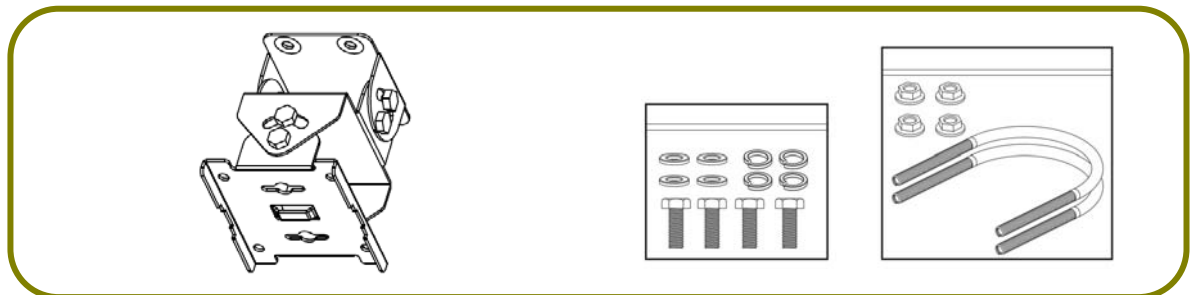

Mount Kit



Note

Do not use Ethernet cables with molded hood boot.

OK  Only Plug

NG  Cable with Molded Hood Boot

2

Descriptions of Components

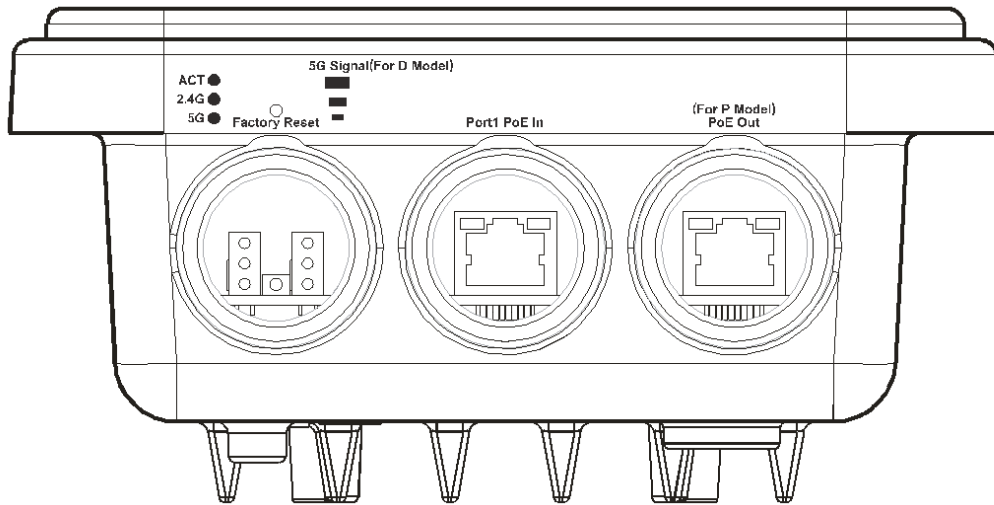

LED	Status	Explanation
ACT	Off	The system is not ready or has failed.
	Blinking	The system is ready.
2.4G / 5G /	On	Wireless function is ready.
	Off	Wireless function is not ready.
	Blinking	Data is being transmitted (sending/receiving).
5G Signal (For D Model)		The signal strength (excellent) > -50dBm.
5G Signal (For D Model)		The signal strength (good) is between -66dBm ~ -51dBm.
5G Signal (For D Model)		The signal strength (fair) is between -73dBm~ -67dBm.
5G Signal (For D Model)		No signal or the signal strength is <-73dBm.

Interface	Description
Factory Reset	Restore the default settings. Usage: Switch on the access point. Press and hold reset button for at least 10 seconds. VigorAP will restart with the factory default configuration. Before pressing the button, the cover should first be removed by rotating it with a torque of 13 kgf-cm. After the access point has been reset, replace the cover and lock it with the same amount of torque.
Port1 PoE In	Connector for receiving power from another device.
PoE Out (for P Model)	Connector for supplying power to another device.



Note

For the sake of safety, keep the access point away from children.

3

Mounting the Access Point

The VigorAP can be pole mounted depending on the installation environment. This section will guide you through installing the VigorAP.



Note

For the sake of personal safety, only trained and qualified personnel should install this access point.

3.1 Antennas Installation

1. Remove the protective cap.

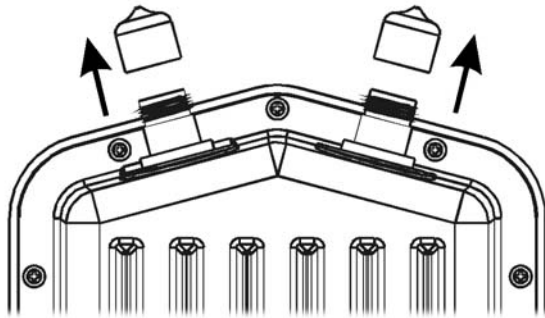

2. Insert the antennas and fasten them by rotating clockwise.

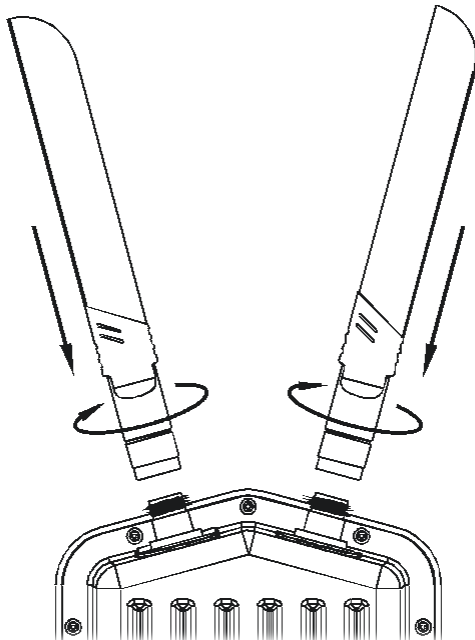

Warning

- Do not open the top cover of the device.
- Installation during thunderstorms could be dangerous.

3.2 Connecting Ethernet Cable(s)

Refer to the following steps to attach the Ethernet cable and waterproof head. (Take VigorAP 920RP as an example.)

1. Remove the cable cover for Ethernet Port (e.g., **Port 1 PoE In**).
2. Before connecting, verify that the cable has a rubber seal and that it is not damaged.



Note

To prevent the enclosure from water leakage, make sure the Ethernet cable gland and the rubber gasket are present and installed properly.

3. Inserting RJ-45 connector into the port.

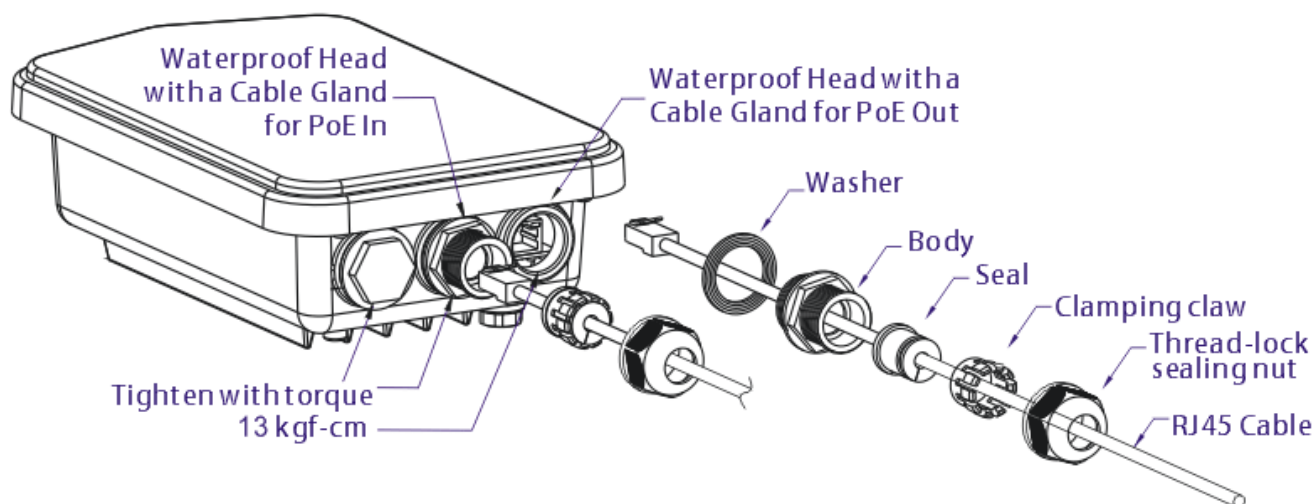

4. Use an adjustable wrench and tighten the thread-lock sealing nut with torque 10 kgf-cm.



Note

Do not pull the cable backwards; the force might break the plug.

Reconnecting Ethernet Cable

1. Loosen the thread-lock sealing nut.
2. Loosen the clamping claw and seal.
3. Loosen the body and washer.
4. Remove the cable.

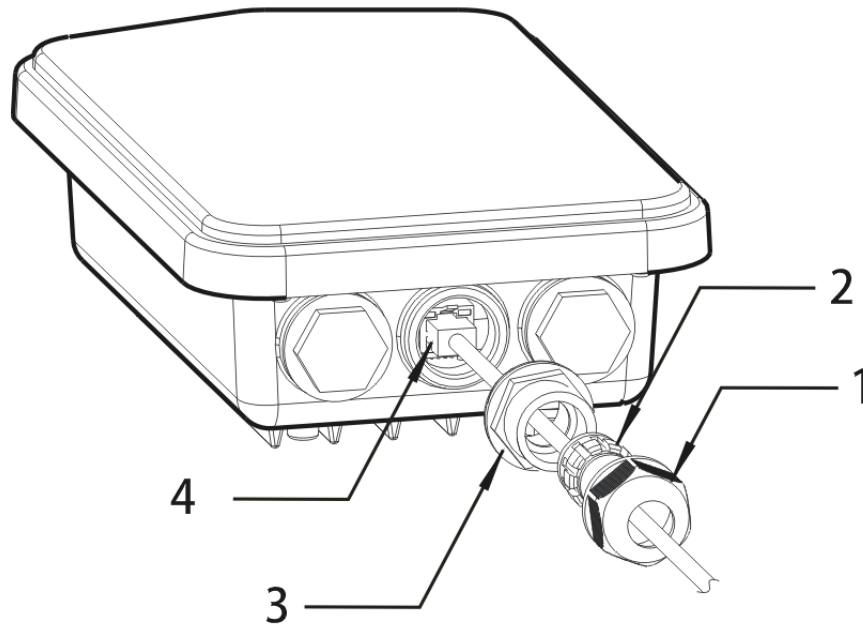

5. To reattach the cable, follow the above steps in reverse.



Note

The diameter for the Ethernet cable shall be limited between 4.3mm to 5.9mm.

3.3 Access Point Installation – Pole Mount

1. Find a suitable location for installing the access point.
2. Select a mounting point on a pole.
3. Remove the mounting plate from the mount kit by removing the four mounting screws.

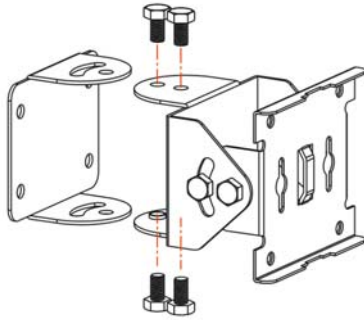

4. Attach the VigorAP920 to the mounting plate. Lock the screws with torque of 20 kgf-cm.

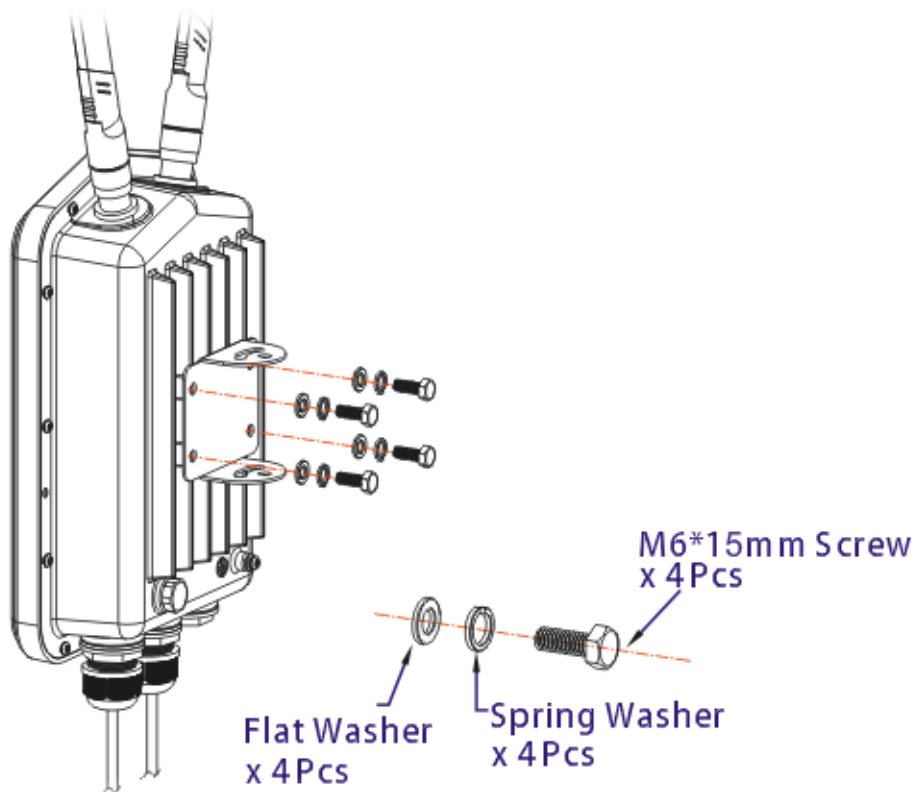

5. Fasten the mount kit on the pole with nut screws and with torque of 20 kgf-cm.

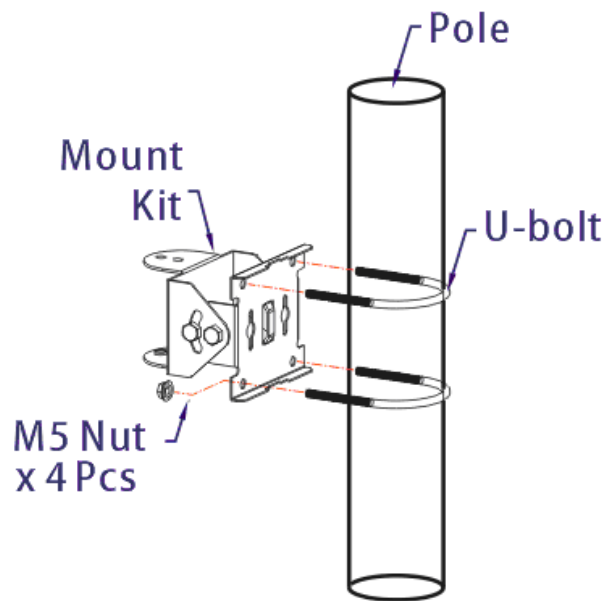

Note

The diameter for a pole shall be limited between 35mm to 53mm.

6. Fasten the access point to the mount kit with screws (torque of 20 kgf-cm) as shown in the following figure.

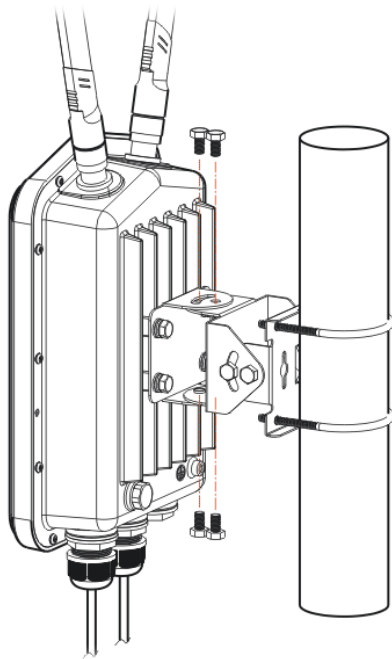

Note

Before connecting the access point to the mount kit, make sure it is oriented with the LED indicators pointing downwards.

3.4 Grounding Access Point

In outdoor installations and before powering the access point with AC power, VigorAP must be grounded prior to wire installation.

1. Take out the ground cable from the mount kit.

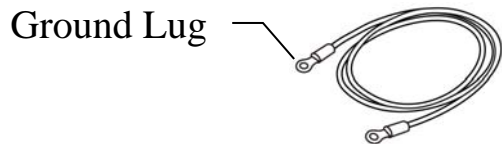

2. Insert a ground rod on the ground.
3. Strip the insulation for the ground lug.
4. Use the appropriate crimping tool to crimp the ground cable to the grounding lug.
5. Connect the ground rod and the VigorAP using the ground cable.

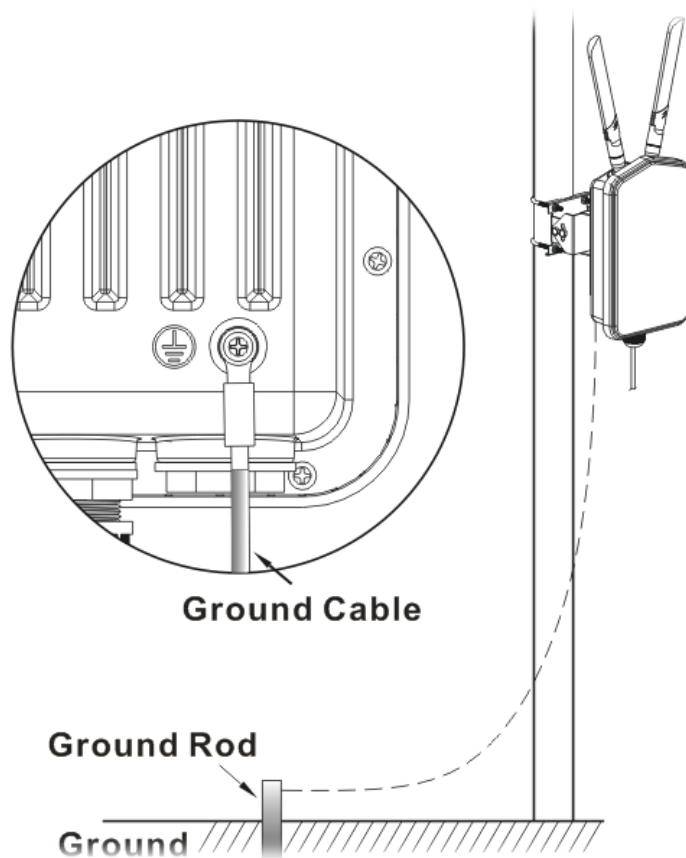

Note

Please consult an electrician if you are uncertain about the type of grounding that is required.

3.5 Powering Access Point

VigorAP 920R/RP can be powered via the PoE input from an in-line power injector or a suitably powered switch port.



Before powering VigorAP, you should:

- Pay attention to local and national electrical codes.
- Not place the power injector / VigorSwitch in outdoor environment without any protection. Moisture might get into the power injector and cause a short circuit or possible fire.
- Not work on the system during periods of lightning activity to avoid the risk of electric shock, and do not connect or disconnect the Ethernet cables under bad weather.

Below shows two examples of connecting power for VigorAP 920R and VigorAP 920RP.

Example 1: AP920R

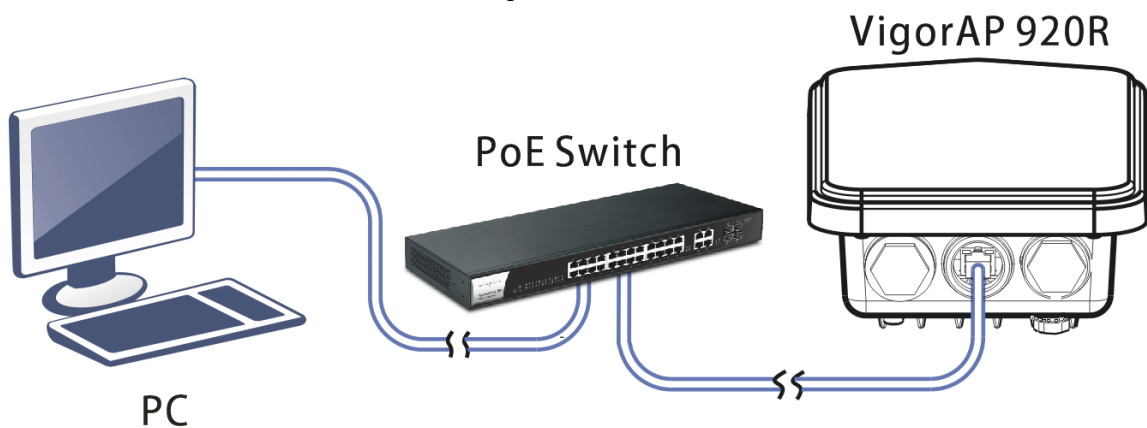

Example 2: AP920RP

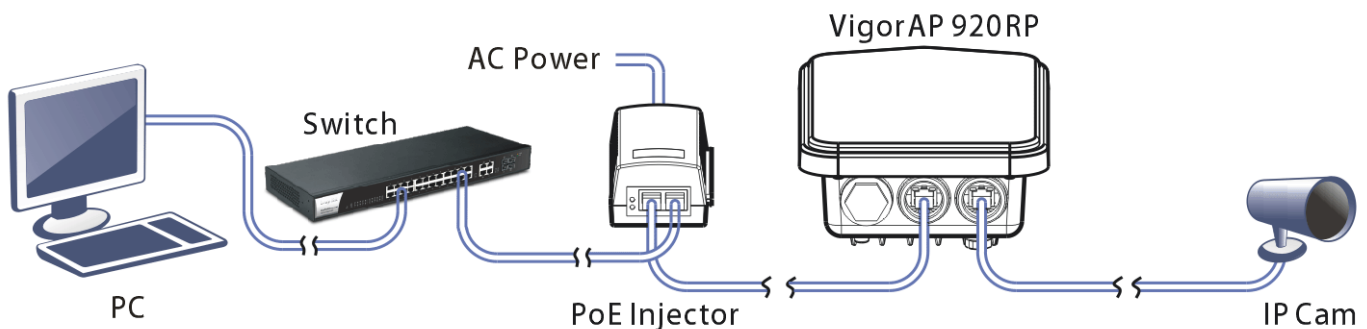

4

Configuring Web Pages

This section will guide you through the configuration of the settings using a web browser.

1. Make sure your PC is connected to access point correctly.
2. Open a web browser on your PC and type **http://192.168.1.2**. A pop-up window will open asking you for a username and password. Please type “admin/admin” for Username/Password and click **Login**.

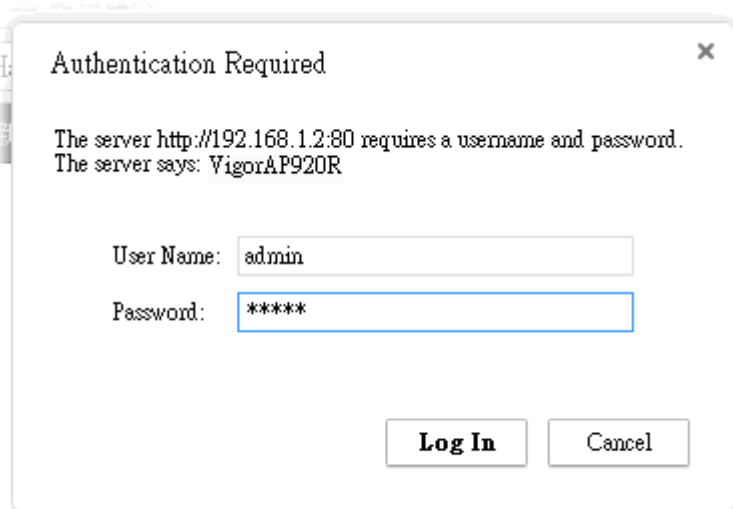

Authentication Required

The server http://192.168.1.2:80 requires a username and password.
The server says: VigorAP920R

User Name:

Password:



Note

You may either set up your computer to receive an IP address dynamically from the access point or manually enter an IP address that is within the same subnet as **the IP address of VigorAP 920R**.

- If there is no DHCP server on the network, the VigorAP 920R will have an IP address of 192.168.1.2.
- If there is DHCP available on the network, the VigorAP 920R will receive its IP address via the DHCP server.

3. The **Main Screen** will be displayed. Click **Quick Start Wizard**.

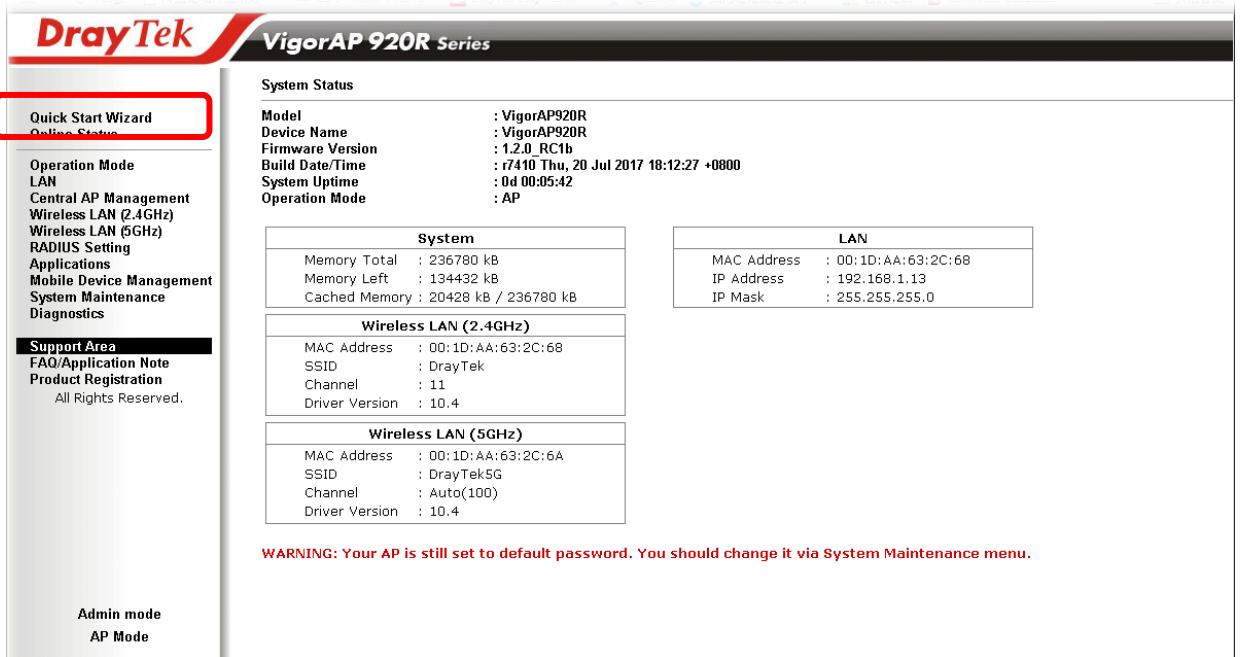

DrayTek VigorAP 920R Series

System Status

Model : VigorAP920R
Device Name : VigorAP920R
Firmware Version : 1.2.0_RC1b
Build Date/Time : r7410 Thu, 20 Jul 2017 18:12:27 +0800
System Uptime : 0d 00:05:42
Operation Mode : AP

System	
Memory Total	: 236780 kB
Memory Left	: 134432 kB
Cached Memory	: 20428 kB / 236780 kB

LAN	
MAC Address	: 00:1D:AA:63:2C:68
IP Address	: 192.168.1.13
IP Mask	: 255.255.255.0

Wireless LAN (2.4GHz)

MAC Address : 00:1D:AA:63:2C:68
SSID : DrayTek
Channel : 11
Driver Version : 10.4

Wireless LAN (5GHz)

MAC Address : 00:1D:AA:63:2C:6A
SSID : DrayTek5G
Channel : Auto(100)
Driver Version : 10.4

WARNING: Your AP is still set to default password. You should change it via System Maintenance menu.

Admin mode
AP Mode

4. This page shows operation modes of the wireless LANs (2.4GHz/5GHz), and whether or not they are enabled. You may alter the settings if you wish.

Quick Start Wizard >> **Operation Mode**

Wireless LAN(2.4GHz)

Operation Mode :

VigorAP acts as a bridge between wireless devices and wired Ethernet network, and exchanges data between them.

Wireless LAN(5GHz)

Operation Mode:

VigorAP acts as a bridge between wireless devices and wired Ethernet network, and exchanges data between them.

Operation Mode

Wireless(2.4GHz)

Wireless(5GHz)

Next >

Cancel

- The subsequent page is for configuring the 2.4G wireless connection. Select one of the five operation modes. The following figure shows the configuration page for the AP (Access Point) operation mode. Configuration pages for other operation modes will differ. In this example, choose **AP** and click **Next** to configure the following page.

Quick Start Wizard >> Wireless LAN (2.4GHz)

Channel :

Main SSID :

Security Key:

Enable Guest Wireless

SSID:

Security Key:

Enable Bandwidth Limit

Upload Limit 13672 Kbps

Download Limit 64 Kbps

Enable Station Control

Connection Time 2550 Min(s)
1days 18hours 30mins

Reconnection Time 1128 Min(s)
0days 18hours 48mins

Operation Mode: Wireless(2.4GHz) Wireless(5GHz)

- After completing the configuration for wireless LAN (2.4GHz), click **Next**. The configuration page for wireless LAN (5GHz) will be shown. The following figure shows the AP configuration page.

Quick Start Wizard >> 5G Security

Channel :

Main SSID :

Security Key:

Enable Guest Wireless

SSID:

Security Key:

Enable Bandwidth Limit

Upload Limit 20689 Kbps

Download Limit 7931 Kbps

Enable Station Control

Connection Time 1226 Min(s)
0days 20hours 26mins

Reconnection Time 834 Min(s)
0days 13hours 54mins

Operation Mode: Wireless(2.4GHz) Wireless(5GHz)

7. When you have completed making changes to settings for wireless LAN (5GHz), click **Next**. The following final page will be shown. If you are satisfied with the changes you have made, click **Finish**. You may verify your settings by navigating to **Online Status** on the Main Screen.

Quick Start Wizard

Vigor Wizard Setup is now finished!

Basic settings for "AP920R" is completed.

Press Finish button to save and finish the wizard setup.

Note that the configuration process takes a few seconds to complete.

< Back

Finish

Cancel



Note

Under **System Maintenance**, you can change the access point's default admin password. You should do this as soon as possible to prevent unauthorized access to the VigorAP's management interface.

Contacting DrayTek

If the access point still cannot work correctly after trying many efforts, please contact your dealer for further help right away. For any questions, please feel free to send e-mail to support@draytek.com.

Safety

Instructions

- Read the installation guide thoroughly before you set up the access point.
- The access point is a complicated electronic unit that may be repaired only by authorized and qualified personnel. Do not try to open or repair the modem yourself.
- Keep the package out of reach of children.
- When you want to dispose of the access point, please follow local regulations on conservation of the environment.

GPL Notice

This DrayTek product uses software partially or completely licensed under the terms of the GNU GENERAL PUBLIC LICENSE. The author of the software does not provide any warranty. A Limited Warranty is offered on DrayTek products. This Limited Warranty does not cover any software applications or programs.

To download source codes please visit:

<http://gplsource.draytek.com>

GNU GENERAL PUBLIC LICENSE:

<https://gnu.org/licenses/gpl-2.0>

Version 2, June 1991

For any question, please feel free to contact DrayTek technical support at support@draytek.com for further information.

FCC WARNING

Federal Communications Commission Statement

This device complies with FCC Rules Part 15. Operation is subject to the following two conditions:

- This device may not cause harmful interference.
- This device must accept any interference received, including interference that may cause undesired operation.

This equipment has been tested and found to comply with the limits for a class B digital device, pursuant to Part 15 of the Federal Communications Commission (FCC) rules. These limits are designed to provide reasonable protection against harmful interference in a residential installation. This equipment generates, uses, and can radiate radio frequency energy and, if not installed and used in accordance with the instructions, may cause harmful interference to radio communications. However, there is no guarantee that interference will not occur in a particular installation. If this equipment causes harmful interference to radio or television reception, which can be determined by turning the equipment off and on, the user is encouraged to try to correct the interference by doing one or more of the following measures:

- Reorient or relocate the receiving antenna.
- Increase the separation between the equipment and receiver.
- Connect the equipment into an outlet on a circuit different from that to which the receiver is connected.
- Consult the dealer or an experienced radio/TV technician for help.

FCC Caution

Any changes or modifications not expressly approved by the party responsible for compliance could void the user's authority to operate the equipment.

The antenna(s) used for this transmitter must not be co-located or operating in conjunction with any other antenna or transmitter.

RF exposure

This equipment must be installed and operated in accordance with provided instructions and the antenna(s) used for this transmitter must be installed to provide a separation distance of at least 20 cm from all persons and must not be co-located or operating in conjunction with any other antenna or transmitter.