

Dualit®

GUARANTEE AND
INSTRUCTIONS FOR
DUALIT MINI OVEN



UK 06/05

QUICK GUIDE

These tables are only to be used as a guide, Cooking times may vary

BAKING

FOOD	TEMP °C	RACK	TIME
Bread	190	D	30 - 35 min
Chicken breast	230	C	30 - 35 min
Cookies	175	C	10 - 12 min
Thin pizza (fresh)	230	C	5 - 10 min

CONVECTION COOKING

FOOD	TEMP °C	RACK	TIME
Thick pizza (frozen)	230	B	10 - 15 min
Sponge cake	180	C	20 - 25 min
Jacket potato	230	B	40 - 60 min
Brownies	175	C	10 - 15 min

RACK POSITION

Locking Bracket

To slide the rack past the locking bracket in position A or B, angle the tray upwards under the bracket then slide past and push fully back into position.

This will stop the rack from accidentally sliding out when removing foods.

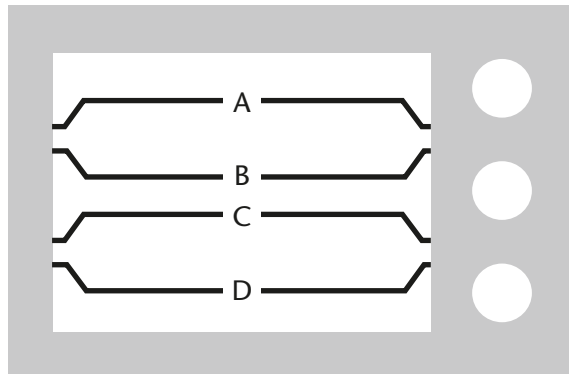

GRILLING

FOOD	TEMP °C	RACK	TIME
Bacon	200	B	10 - 15 min
Sausages	220	B	10 - 15 min
Chicken breast	175	C	15 - 30 min
Fish	220	B	10 - 12 min

ALWAYS LEAVE DOOR AJAR WHEN GRILLING

IMPORTANT SAFEGUARDS

When using an electrical appliance, basic safety precautions should always be followed, including the following:

READ ALL INSTRUCTIONS

- Do not touch hot surfaces. Use handles or knobs.
- To protect against electrical shock, do not place any part of the oven, or cordset, in water or any other liquid. See cleaning instructions.
- Close supervision is necessary when any appliance is used by or near children.
- **UNPLUG FROM OUTLET WHEN NOT IN USE AND BEFORE CLEANING.**
- Allow to cool before cleaning or handling.
- Do not operate any appliance with a damaged cord or plug or after the appliance has malfunctioned or has been dropped or damaged in any way or is not operating properly. Return the oven to the nearest Dualit Repair Centre for examination, repair or mechanical or electrical adjustment.
- The use of accessory attachments not recommended by Dualit may cause injury.
- Do not use outdoors.
- Do not let cord hang over the edge of the table or countertop where it could be pulled on inadvertently by children or pets, or touch hot surfaces which could damage the cord.

- Do not place oven on or near a hot gas or electric burner or in a heated oven.
- Do not use this oven for anything other than its intended purpose.
- Extreme caution should be exercised when using containers constructed of materials other than metal or oven proof glass in the oven.
- To avoid burns, use extreme caution when removing tray or disposing of hot grease.
Always use heatproof gloves.
- When not in use, always unplug the unit. Do not store materials other than manufacturers recommended accessories in this oven.
- Do not place any of the following materials in the oven: paper, cardboard, plastic and similar products.
- Empty the crumb tray regularly. Do not cover crumb tray or any part of the oven with metal foil, this will cause overheating of the oven.
- Oversize foods, metal foil packages and utensils must not be inserted in the toaster oven grill, as they may involve a risk of fire or electric shock.
- A fire may occur if the oven is covered or touching flammable materials such as curtains, draperies and walls, when in operation.
- **WARNING:** Do not operate under wall units or any combustible materials.
- Use oven gloves to remove any stored object on top of the oven.

IMPORTANT SAFEGUARDS

- Should any part of the appliance catch fire, do not attempt to extinguish it with water. Smother external flames with a damp cloth or fire blanket. Never attempt to open the oven door if the oven should catch fire.
- Do not attempt to dislodge food when the oven is plugged into electrical outlet.
- **Warning: To avoid possibility of fire, NEVER leave the oven unattended during use.**
- Use recommended temperature settings for baking and roasting.
- Do not rest cooking utensils or baking dishes on glass door.
- Turn the timer dial to the off position to turn off the oven.
- Do not store any item on top of the appliance when in operation.
- The appliance must only be used in an upright position, never lying down, tilted or upside down.
- Do not insert anything in the ventilation slots and do not obstruct them.
- The door or the outer surface may get hot when the appliance is operating.
- **The exterior walls can get very hot when in use. Keep out of reach of children**
- Use extreme caution when removing tray or disposing of hot grease.
- Do not clean with metal scouring pads. Pieces can break off the pad and touch electrical parts, creating a risk of electric shock.

SAVE THESE INSTRUCTIONS

SPECIAL CORD SET INSTRUCTIONS

A short power supply cord is provided to reduce the risks resulting from becoming entangled in or tripping over a longer cord. Longer extension cords are available and may be used if care is exercised in their use.

If a long extension cord is used, the marked electrical rating of the extension cord must be at least as great as the electrical rating of the appliance, and the longer cord should be arranged so that it will not drape over the countertop or tabletop where it can be tripped over or pulled on by children.

FOR HOUSEHOLD USE ONLY

NOT INTENDED FOR COMMERCIAL USE

THIS IS AN ATTENDED APPLIANCE

Please read and keep these instructions handy.

These instructions will help you to use your Dualit Oven to its fullest so that you will achieve consistent, professional results.

FEATURES AND ACCESSORIES

From defrosting to baking to grilling the oven will assist you in cooking a great range of food in one versatile machine.

- The Dualit mini oven features a unique Double Glazed Coolwall window
- 1. Pilot light and temperature indicator light
- 2. Temperature Dial for Baking, Grilling, Convection and Toasting
- 3. Function Dial for Bake, Grill, Convection or Defrost
- 4. Timer with bell - settings 0 – 60 min and 'always on' position
- 5. Wire Oven rack - four positions, see page 2
- 6. Baking / Grilling pan with reversible grill tray
- 7. Baking Sheet
- 8. Drip Tray
- Interior oven light
- Fan assisted cooking
- Cord Tidy
- Adjustable foot
- Stainless steel construction with polished aluminium end castings

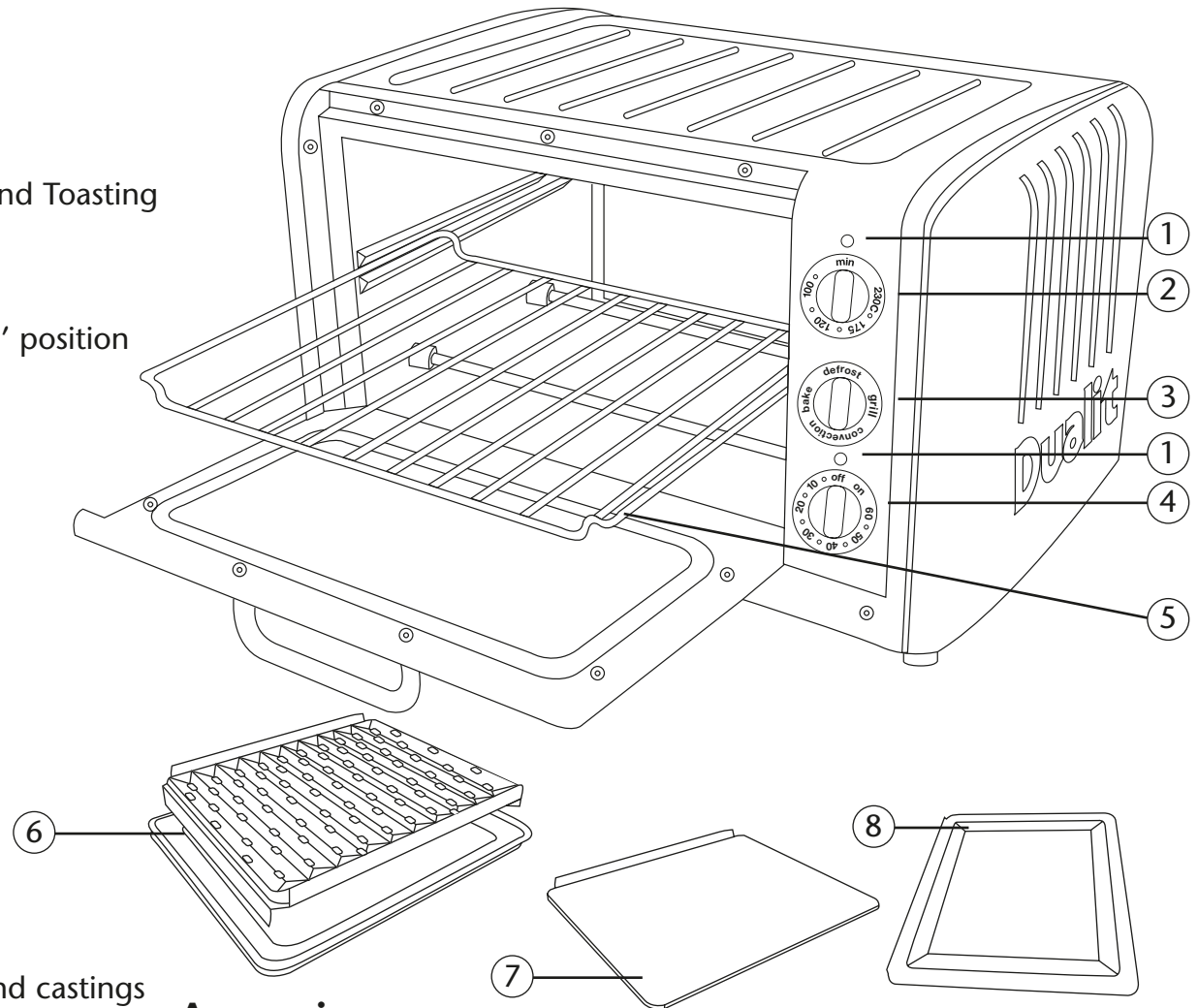

Accessories

Included: 2 Wire racks, Grilling pan, Baking sheets and Drip tray

BEFORE PLUGGING IN

Place your oven on a flat surface. Adjust rear foot until the oven rests square. Prior to use ensure any object is not touching the oven and never place on heat sensitive worktop.

KEEP OUT OF REACH OF CHILDREN

GENERAL GUIDELINES

Use oven gloves to remove any stored object on top or inside of the oven. The exterior walls get very hot when in use. Grilling pan only fits onto rack in positions B, C & D, see page 2.

Baking - The baking function is used for any food product you would put in your large kitchen oven, such as roasting meats, chicken, baking, cakes, cookies and double sided toasting.

Convection - Convection baking uses an internal fan to circulate heated air around the food. This function produces fast, even cooking results. Please note convection function will reduce cooking times. Some foods may not be ideal for convection cooking.

Grill - Only the top heating elements are used, ideal for a healthier way of cooking meats, sausages, bacon. This function would also be used for toasting and top browning gratins or casseroles.

Defrost - Place frozen item in oven and set function to defrost, Turn on using the timer for required period. Only the fan activates to speed up the defrosting time. Food is thawed gently & evenly without cooking.

USING YOUR MINI OVEN

Unwind the power cord. Check that the crumb tray is in place and that there is nothing in the oven. Plug power cord into socket.

The 'Timer' is the main ON/OFF switch. Turn timer knob clockwise for 'runback timing' or anticlockwise for 'permanent on'.

The red light will illuminate when timer is running and the green light will illuminate when set temperature is reached.

Always allow a 3/4 inch gap from food to the top heating elements.

BAKE - To Bake, set temperature dial to the desired temperature and turn the function dial to 'bake'. Turn timer knob to required time setting. For best results preheat oven for 5 minutes.

CONVECTION - Set to required temperature and function then turn on. The Fan will evenly distribute the heat and provide even and fast cooking results. For best results preheat oven for 5 minutes.

GRILL - When grilling, add approximately 1/4 cup of water to the bottom of the grilling pan to reduce sizzling and splattering. Note: Do not use the grill tray without the grilling pan. There are two positions for the grill tray so that a variety of thicknesses of foods can be grilled. In most cases the oven rack should be in position B. See Rack position diagram on pages 2 and 5.

To grill, set temperature and function dial to grill. Preheat oven for five minutes with door closed. After five-minute preheat period, place the grill pan in the oven. **Always leave the door slightly ajar when grilling.**

TOAST - Double sided toasting - Set function dial to Bake. Place wire rack in position C and place bread directly onto the wire rack. Turn the timer to 'Always on' and set temperature at 230°C, toast until desired browning is achieved, (approximately 4-5 minutes). Remove with oven gloves. **Always leave the door slightly ajar when toasting. Never leave oven unattended when toasting bread, as fire can easily result.**

CLEANING

Always allow the oven to cool completely before cleaning

- Always unplug the oven from the electrical outlet.
- Do not use abrasive cleansers (especially oven cleaners based on bicarbonate of soda) , as they will damage the finish. Simply wipe the exterior with a clean damp cloth and dry thoroughly.
- To clean interior walls, use a damp cloth and a mild liquid soap solution on a sponge. Never use harsh abrasives or corrosive products. These could damage the oven surface.
- To remove crumbs, slide out the crumb tray and discard crumbs. Wipe clean and replace. Crumb tray is dishwasher safe.
To remove baked-on grease, soak the tray in hot sudsy water or use nonabrasive cleaners. Never operate the oven without crumb tray in place.
- Wierack, grilling pan and drip tray are dishwasher safe. If heavily soiled, soak in hot sudsy water or use a nylon scouring pad or brush.
- Never wrap the cord around the outside of the oven. Use the cord storage cleats on the back of the oven.

IMPORTANT

After cooking greasy foods and after your oven has cooled, always clean top interior of oven. If this is done on a regular basis, your oven will perform like new. Removing the grease will help to keep the oven consistent, cycle after cycle.

GUARANTEE

If your machine fails within one year from the date of purchase, we will repair or replace it free of charge provided:

- You have not misused, neglected or damaged it.
- It has not been modified or you have refitted the plug.
- You supply your receipt to show when you bought your mini oven.

The guarantee does not affect your statutory rights.

Dualit does not assume any responsibility for incidental or consequential damages.

In the interest of improving products, Dualit Ltd reserves the right to change specifications without prior notice.

SERVICE AND CUSTOMER CARE

Should the bulb fail in the interior light - see overleaf. Spare bulbs are available from Customer helpline.

If your appliance fails to operate properly while in use under normal household conditions within the warranty period, simply return the complete appliance to the shop where you purchased it or contact Dualit Ltd for further information.

Dualit Customer Helpline: +44 (0) 1293 652 500

e-mail: info@dualit.com

REPLACING THE OVEN LIGHT

Before the maintenance is started involving electrical parts of the appliance, it must be disconnected from the power supply.

- Switch off the electrical supply and unplug the appliance
- Let the oven cavity and the heating elements cool down
- Unscrew the protective glass cover
- Unscrew and replace the bulb with a new one suitable for high temperatures (230°C) having the following specifications: 240V, 25 watt
- Refit the protective cover

NOTE: Oven bulb replacement is not covered by your guarantee.

CAUTION: Lamp replacement should only be carried out while the appliance is disconnected from the supply circuit. Use 25 watt or smaller, 240 volt, type E14 base lamp.

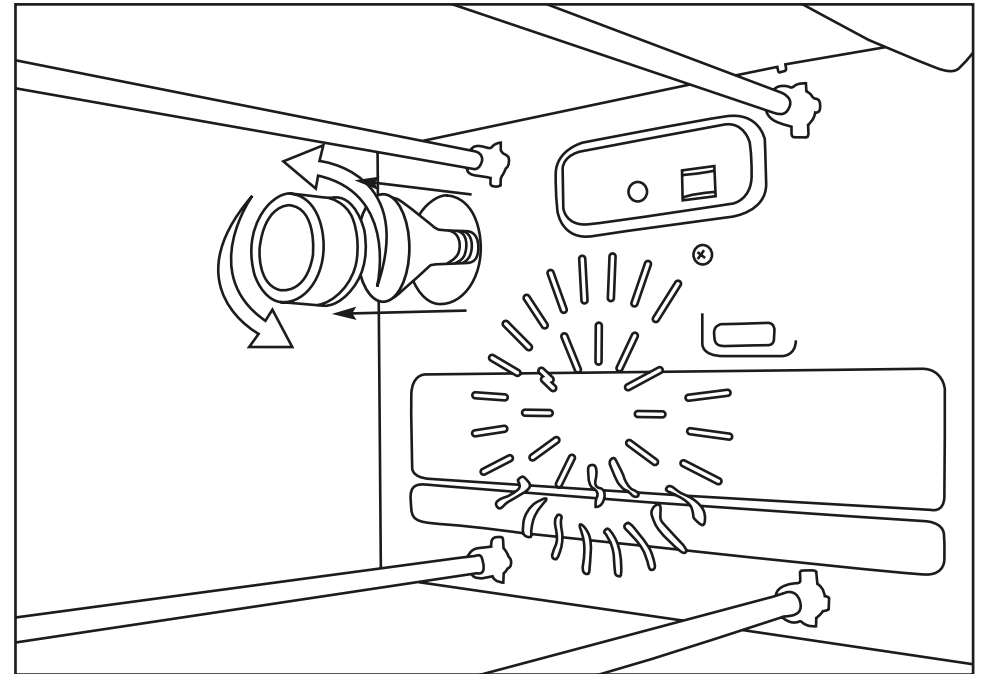

Dualit  CE Compliant to
89/336/EEC (EMC directive) and
73/23 & 93/68/ EEC (LV directive)

DUALIT LIMITED COUNTY OAK WAY CRAWLEY WEST SUSSEX RH11 7ST
TELEPHONE: +44 (0) 1293 652 500 FACSIMILE: +44 (0) 1293 652 555
EMAIL: info@dualit.com WEB: www.dualit.com