

# **Dust Networks**

## **D1120 Evaluation Kit**

### **Quick Start Guide**



---

**Trademarks**

Dust Networks, the Dust Networks logo, and SmartMesh are trademarks of Dust Networks, Inc. All third party brand and product names are the trademarks of their respective owners and are used solely for informational purposes.

**Copyright**

This documentation is protected by United States and international copyright and other intellectual and industrial property laws. It is solely owned by Dust Networks, Inc. and its licensors and is distributed under a restrictive license. This product, or any portion thereof, may not be used, copied, modified, reverse assembled, reverse compiled, reverse engineered, distributed or redistributed in any form by any means without the prior written authorization of Dust Networks, Inc.

RESTRICTED RIGHTS: Use, duplication, or disclosure by the U.S. Government is subject to restrictions of FAR 52.227-14(g) (2)(6/87) and FAR 52.227-19(6/87), or DFAR 252.227-7015 (b)(6/95) and DFAR 227.7202-3(a) and any and all similar and successor legislation and regulation.

**Disclaimer**

THIS DOCUMENTATION IS PROVIDED "AS IS" WITHOUT WARRANTY OF ANY KIND, EITHER EXPRESSED OR IMPLIED, INCLUDING BUT NOT LIMITED TO, THE IMPLIED WARRANTIES OF MERCHANTABILITY OR FITNESS FOR A PARTICULAR PURPOSE.

THIS DOCUMENTATION MIGHT INCLUDE TECHNICAL INACCURACIES OR OTHER ERRORS. CORRECTIONS AND IMPROVEMENTS MIGHT BE INCORPORATED IN NEW VERSIONS OF THE DOCUMENTATION.

**EMI Warning**

This equipment has been tested and found to comply with the limits pursuant to Part 15 of the FCC rules. These limits are designed to provide reasonable protection against harmful interference in an appropriate installation. This equipment generates, uses, and can radiate radio frequency energy and, if not installed and used in accordance with the instructions, may cause harmful interference to radio communication. However, there is no guarantee that interference will not occur in a particular installation. If this equipment does cause harmful interference to radio or television reception, which can be determined by turning the equipment off and on, the user is encouraged to try to correct the interference by one or more of the following measures:

- (1) Reorient or relocate the receiving antenna.
- (2) Increase the separation between the equipment and receiver
- (3) Connect the equipment into an outlet on a circuit different from that to which the receiver is connected.
- (4) Consult the dealer or an experienced radio or television technician for assistance.

# Contents

## 1 About This Guide

- Related Documents ..... iii
- Conventions Used ..... iii

## 1 M1020 Evaluation Module

- M1020 Evaluation Module ..... 1
- Connector P1 ..... 2
- Connector P2 ..... 3
- Serial Interface ..... 4
- Power Supply ..... 4
- Absolute Maximum Ratings ..... 4
- Recommended Operating Conditions ..... 5
- Wireless Specifications ..... 5
- Antenna ..... 5
- Regulatory Information ..... 6

## 2 SmartMesh Manager

- Description ..... 7
- Connections ..... 8
- Technical Specifications ..... 8
- Regulatory Information ..... 9

## 3 Setting Up a Network

- Setting Up the SmartMesh Manager ..... 11
- Setting Up the Network ..... 11



# About This Guide

This guide provides information required to successfully demonstrate the capabilities of the D1100 Evaluation Kit. It provides various pinout and connector information for attaching sensors to a mote Evaluation Module and instructions for setting up a network.

## Related Documents

The following documents are available for a SmartMesh Network:

- *D1120 Evaluation Kit Quick Start Guide* (this guide)
- *SmartMesh Manager Application Programming Interface (API) Guide*
- *M1020 Mote Integration Guide*
- *SmartMesh Network Planning Guide*
- *SmartMesh Network Administration Guide*

## Conventions Used

The following conventions are used in this guide:

- `Computer type` indicates information that you enter, such as specifying a URL.
- **Bold type** indicates buttons, fields, and menu commands.
- *Italic type* is used to introduce a new term.



**Note:** Notes provide more detailed information about concepts.



**Cautions:** Cautions advise you about actions that might result in a loss of data.



**Warning!** Warnings advise you about actions that may cause physical harm to the hardware or your person.



# M1020 Evaluation Module

This chapter provides specifications for the M1020 Evaluation Module (M1020-EVM) provided in the D1120 Evaluation Kit. The M1020-EVM can be used as a reference design for integrating an M1020 Mote into a self-contained device.

## M1020 Evaluation Module

The M1020-EVM consists of an M1020-A Mote, packaged with an antenna, battery holder, status LEDs, I/O connectors, and a recessed reset switch. The M1020-EVM board is packaged in a plastic enclosure suitable for mounting on a wall or other vertical surface.

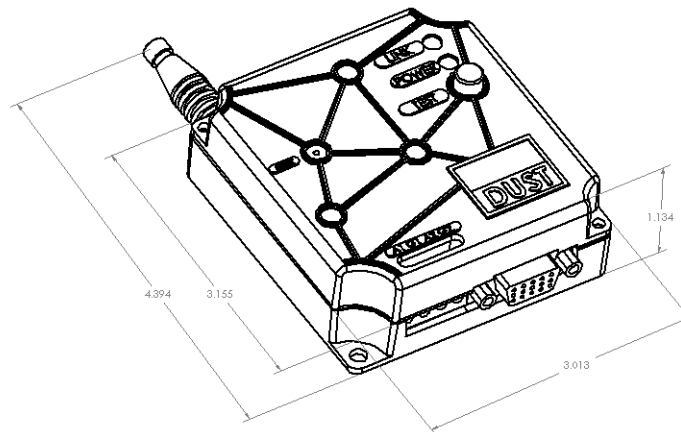

Figure 1-1. M1020 Evaluation Module

# Connector P1

Connector P1 is a 4-position terminal block connector that accepts 12-22 AWG wire. It assumes 0 to 5 V inputs, and contains internal filter circuitry for 60 Hz noise.

**Table 1-1. P1 Connector Pinouts**

Pin Number	Pin Name	I/O	Description
1	A1	I	Analog input 1 (0 - 50)
2	GND	I	Ground
3	A2	I	Analog input 2 (0 - 50)
4	GND	I	Ground



**Warning:** Reverse biasing these inputs may result in damage to the device.



## Connector P2

Connector P2 is an HD-15 female connector, as shown in Figure 1-2. It assumes 0 to 1.5 V analog inputs, and is unfiltered. All digital I/O are LVTTTL (3 V) signaling.

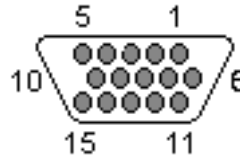

Figure 1-2. HD-15 Female Connector

Table 1-2. P2 Connector Pinouts

Pin Number	Pin Name	I/O	Description
1	TX	O	UART Transmit
2	D5	I/O	Digital I/O 5 or SOF (see the <i>M1020 Mote Integration Guide</i> , Appendix C)
3	D2	I/O	Digital I/O 2
4	A7	I	Analog input 7
5	A4	I	Analog input 4
6	RX	I	UART Receive
7	D6	I/O	Digital I/O 6
8	D3	I/O	Digital I/O 3
9	GND	I	Ground
10	A5	I	Analog input 5
11	D7	I/O	Digital I/O 7
12	D4	I/O	Digital I/O 4 or CTS (see the <i>M1020 Mote Integration Guide</i> , Appendix C)
13	D1	I/O	Digital I/O 1
14	A6	I	Analog input 6
15	A3	I	Analog input 3

**Note:** All I/O, including UART, are at LVTTTL (3 V) signaling levels. An external level converter is required for RS-232 communications.

⚠️ **Warning:** Reverse biasing these inputs may result in damage to the device.

## Serial Interface

Connector P2 provides a flow-controlled serial interface with timing information (using TX, RX, CTS, and SOF), as described in the *M1020 Mote Integration Guide*, Appendix C. Serial port settings are 9600 bps, 8 data bits, no parity, 1 stop bit.

## Power Supply

The M1020-EVM board is powered by a pair of L91 1.5 V AA lithium batteries (or equivalent), and comes with a standard double AA battery holder. The M1020-EVM does not contain a power switch. Units are tested and shipped in deep sleep mode. To place the device into deep sleep, short pins 1 and 6 on P2, and reset the M1020-EVM. The status LEDs should remain off, and the device remains asleep until it is reset. To activate the unit, press reset with pins 1 and 6 unconnected.

## Absolute Maximum Ratings

Table 1-3. Absolute Maximum Ratings

Parameter	Min	Max	Units	Condition
Supply voltage $V_{BAT} (V_{CC})$	2.7	3.6	V	Referenced to GND
Voltage on any pin	-0.3	$V_{CC} + 0.3$	V	Referenced to GND
Digital I/O current				
Source		2	mA	
Sink		6	mA	
Total I/O		24	mA	
Storage temperature	-40	+85	°C	
Operating ambient temperature	-40	+85	°C	

⚠⚠⚠ **Warning:** The M1020 Mote is an ESD-sensitive device. Use caution when handling in order to prevent permanent damage to the device.

## Recommended Operating Conditions

Table 1-4. Operating Conditions

Parameter	Min	Max	Units	Condition
Analog input impedance		75	k $\Omega$	
Analog input capacitance		40	pF	

## Wireless Specifications

Table 1-5. Wireless Specifications

Parameter	Max	Units
Frequency Band	902 - 928	MHz
RF output power	4	dBm
Transmit data rate	76.8	kbps
Receiver sensitivity (at 15 dB SNR)	-93	dBm
Range		
Outdoors (1m elevation)	>100	m
Indoors	10 - 30 typical	m

## Antenna

Avoid handling the module by its antenna. For best results, place all devices so that the antenna points to the ceiling. Devices placed close to the ground may have a significantly reduced range. In the event of communications difficulties, try changing the orientation of the module.

## Regulatory Information

The FCC ID: SJC-M1020EVM. This device complies with Part 15 of the FCC rules. Operation is subject to the following two conditions:

- (1) This device may not cause harmful interference.
- (2) This device must accept any interference received, including interference that may cause undesired operation.

! **Caution:** Unauthorized modification or changes not expressly approved by Dust Networks™ Inc. could void compliance with regulatory rules, and thereby your authority to use this equipment.

# SmartMesh Manager

This chapter describes the D1120 SmartMesh Manager provided in the D1120 Evaluation kit. The D1120 is used to configure and control a network of M1020 motes, and provides data and configuration information via an XML/RPC interface.

## Description

The D1120 SmartMesh Manager consists of a single board computer and an M1020 mote. The M1020 mote acts as a radio gateway between the single board computer and the Dust Network. An API is provided to allow users to develop custom interfaces or data logging applications. Refer to the *SmartMesh Manager API Guide* for further information.

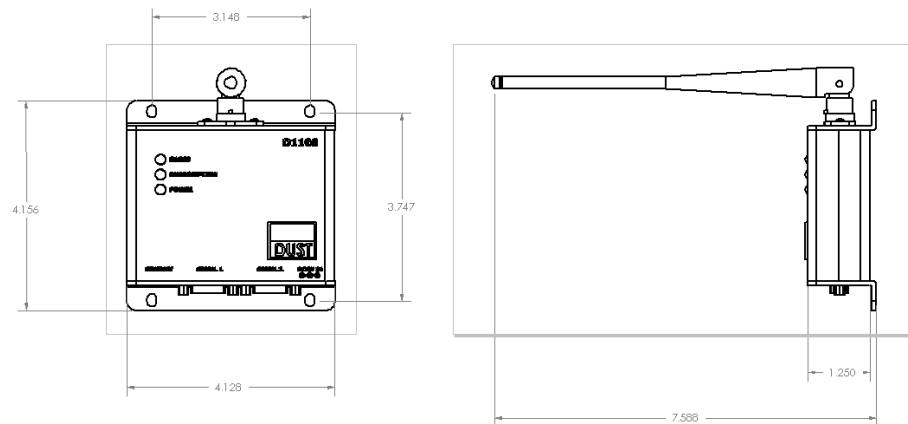

Figure 2-1. SmartMesh Manager (Top View) and Antenna (Side View)

## Connections

The D1120 SmartMesh Manager has the following ports available:

- **10/100 Ethernet port**—Used for connection to a LAN or direct connection to a computer using the cross-over cable provided in the D1120 Evaluation Kit. Refer to the *SmartMesh Manager Administration Guide* for information on configuring the IP address of the SmartMesh Manager.
- **Serial 1 port (RS232)**—Reserved for future connection. 115 kbps maximum. Not flow controlled (TX, RX, ground only).
- **Serial 2 port (RS232)**—Command line interface (38400 bps, 8 data bits, no parity, 1 stop bit. Not flow controlled (TX, RX, ground only).
- **Power**—5 VDC, center positive, 2A.

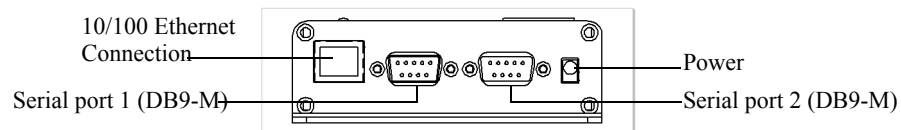

Figure 2-2. SmartMesh Manager Connectors

## Technical Specifications

Table 2-1. Technical Specifications for SmartMesh Manager

Category	Description
Processor	Intel PXA255, 400 MHz
Radio	M1020 gateway mote
Radio operating frequency	902 - 928 MHz, frequency hopping (FCC 15.247)
Transmit power	4 dBm
Receive sensitivity	-93 dBm
Connectors	10/100 Ethernet, 2 RS232 (5 V) serial, 1 power
Power	5VDC, 2A max
Antenna	Nearson 1/2 wave dipole
Range	10-30 m indoors (typical) 100 m outdoors
Environment	-10 °C to +70 °C
API interface	XML/RPC

## Regulatory Information

The FCC ID: SJC-D1120. This device complies with Part 15 of the FCC rules. Operation is subject to the following two conditions:

- (1) This device may not cause harmful interference.
- (2) This device must accept any interference received, including interference that may cause undesired operation.

! **Caution:** Unauthorized modification or changes not expressly approved by Dust Networks™ Inc. could void compliance with regulatory rules, and thereby your authority to use this equipment.





# Setting Up a Network

This chapter describes how to set up a D1120 Evaluation Kit in a simple sensor network. For a more detailed explanation, see the Getting Started Guide that came with your Evaluation Kit.

## Setting Up the SmartMesh Manager

- 1 Install the SmartMesh Console software.
- 2 Connect Manager to the PC using the cross-over cable.
- 3 Connect power to the Manager.
- 4 If necessary, adjust the IP address of the PC to allow connection with the manager.
- 5 Start Console.
- 6 Connect to Manager.
- 7 Go on to set up the network.

## Setting Up the Network

- 1 Power up one evaluation module by resetting it.
- 2 Press the Test button on the module.  
The green Power LED should turn on. If it does not, make sure that the batteries are properly seated. The Link LED starts blinking when the module has found the network. When the module joins the network, the Link LED remains on.
- 3 Form the network by powering up additional modules (repeat steps 1 and 2).
- 4 Use the Console to verify network connectivity. For more information about configuring and managing the network, refer to the *SmartMesh Network Administration Guide*.

