

Toshiba Bluetooth Module Installation

This sheet provides information on installing the Bluetooth module.



This sheet is for information only. The Bluetooth module must be installed by Toshiba or Toshiba OEM dealers.

Installing the Bluetooth Module (Tecra 9000)

Before handling the Bluetooth module, discharge static electricity from your body by touching a metal object. Before installing the Bluetooth module, you will first have to remove the battery pack. Follow the steps below and refer to the following figures.

1. Turn off the power and disconnect the AC adaptor.
2. Turn the computer upside down.
3. Remove the main battery pack and optional secondary battery if one is installed in the Slim Select Bay. Refer to the computer user's manual: Chapter 6, *Power and Power-Up Modes*, for details on removing the main battery pack and Chapter 8, *Optional Devices*, for details on removing the secondary battery.

4. Remove one six-point, M2x4 black flat-head LH-STIX screw securing the Bluetooth module slot cover and lift out the cover.

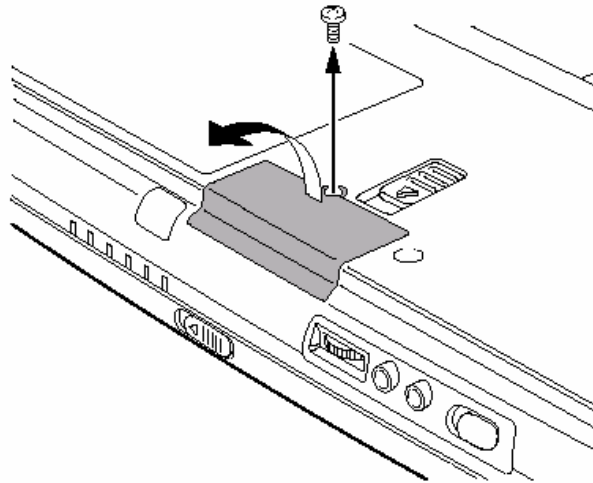

Removing the Bluetooth module slot cover

5. Connect the antenna cables to the connector on the Bluetooth module.



Use tweezers to align the connector and press it into place. Be careful not to apply pressure to the ICs on the Bluetooth module.

6. Hold the card, fit the connector on its bottom side into the computer's connector and press carefully to ensure firm contact.



Hold the Bluetooth module by the sides only. Do not touch the connector on the card or on the computer. Debris on the connectors may cause access problems.

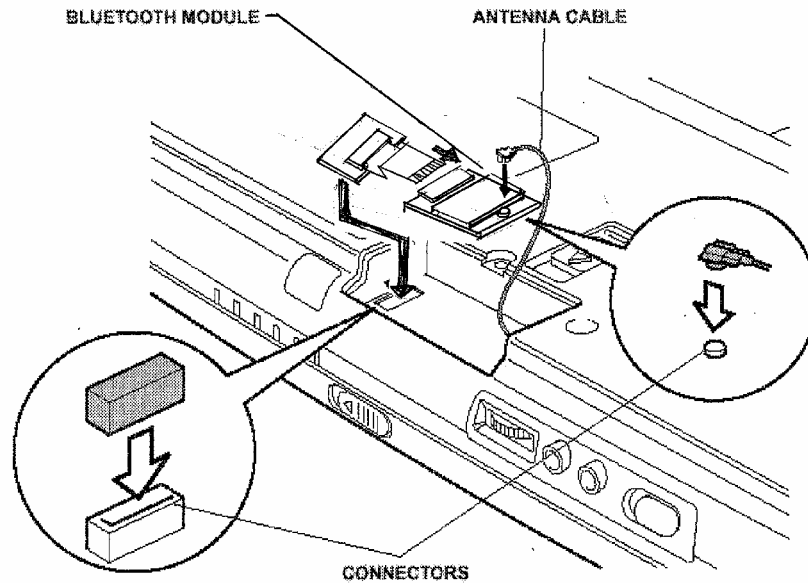

Installing the Bluetooth module (Tecra 9000)

7. Seat the Bluetooth module cover and secure it with one six-point, M2x4 black flat-head LH-STIX screw.

Installing the Bluetooth Module (Portégé 4000)

Before handling the Bluetooth module, discharge static electricity from your body by touching a metal object. To install the Bluetooth module, follow the steps below and refer to the following figures.

1. Turn off the power and disconnect the AC adaptor.
2. Turn the computer upside down.
3. Remove the main battery pack and optional secondary battery if one is installed in the Slim Select Bay. Refer to the computer user's manual: Chapter 6, *Power and Power-Up Modes*, for details on removing the main battery pack and Chapter 8, *Optional Devices*, for details on removing the secondary battery.

4. Remove two six-point, M2x4 black flat-head LH-STIX screws securing the wireless LAN card slot cover and lift up the cover.

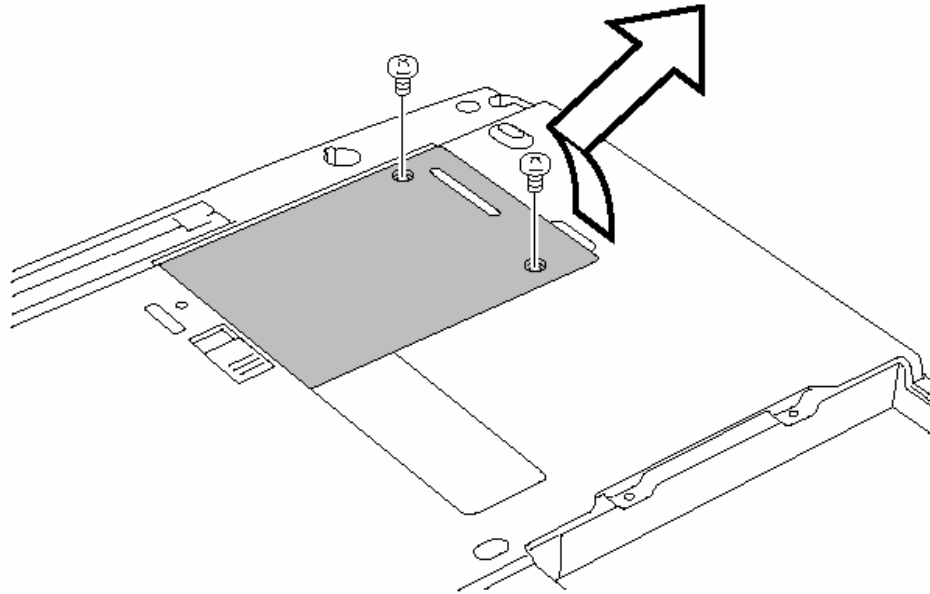

Removing the wireless LAN card slot cover

5. Lift up the Bluetooth module slot cover to remove it.

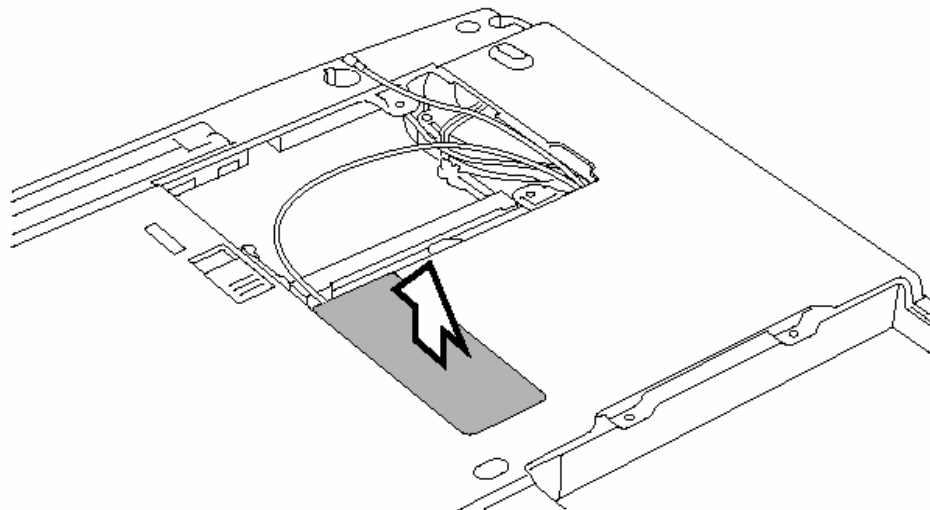

Removing the Bluetooth module slot cover

6. Connect the antenna cable to the connector on the Bluetooth module.



Use tweezers to align the connector and press it into place. Be careful not to apply pressure to the ICs on the Bluetooth module.

7. Hold the card, fit the connector on its bottom side into the computer's connector and press carefully to ensure firm contact.



Hold the Bluetooth module by the sides only. Do not touch the connector on the card or on the computer. Debris on the connectors may cause access problems.

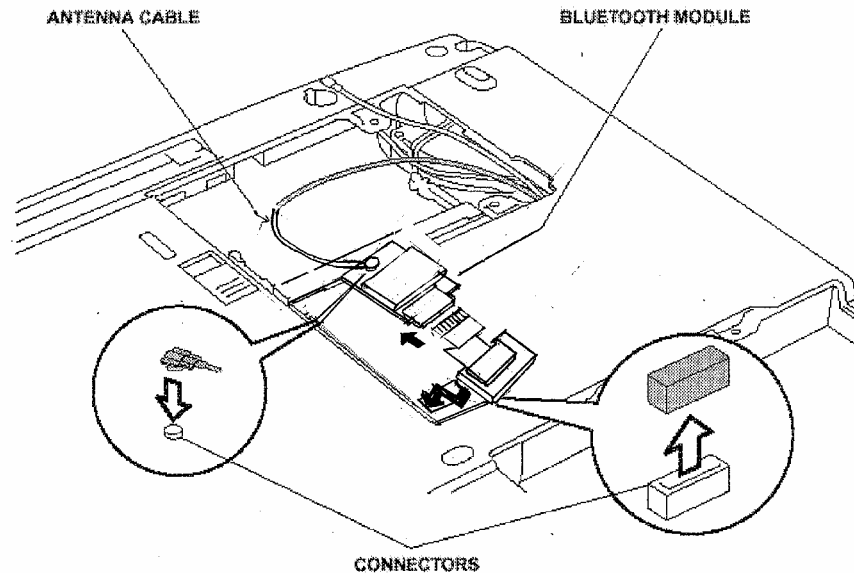

Installing the Bluetooth module

8. Seat the Bluetooth slot cover.
9. Align two tabs on the edge of the wireless LAN card cover with two notches on the wireless LAN card slot and seat the wireless LAN card slot cover.
10. Secure the wireless LAN card slot cover with two six-point, M2x4 black flat-head LH-STIX screws.

Applying labels

The figures below show the locations of labels on the Tecra 9000 and Portégé 4000 series computers. The letters A and B correspond to labels identified in later illustrations. The applied labels will vary according to your computer's configuration.

Label positions

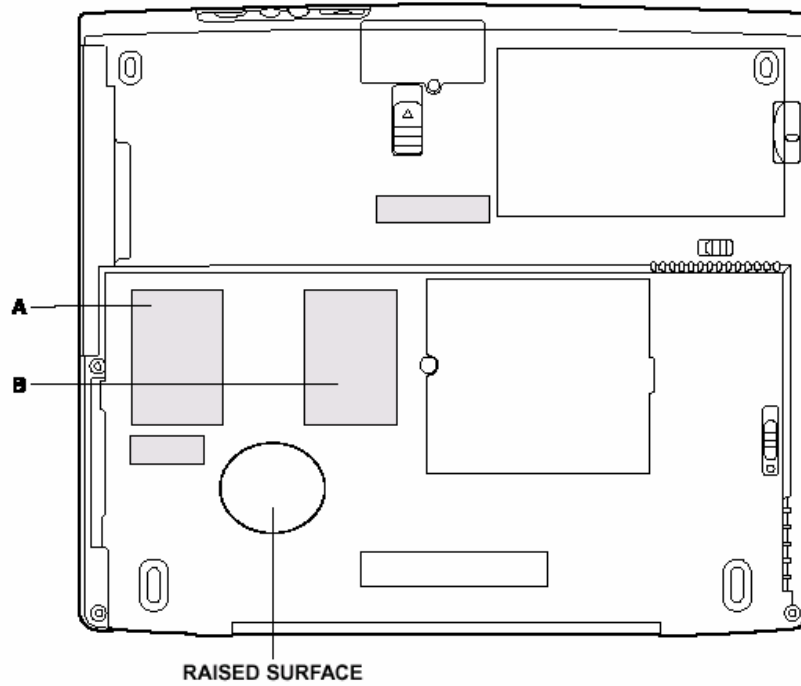

Label positions on the Tecra 9000



There is a round raised surface on the bottom of the Tecra 9000. Do not cover this surface with a label.

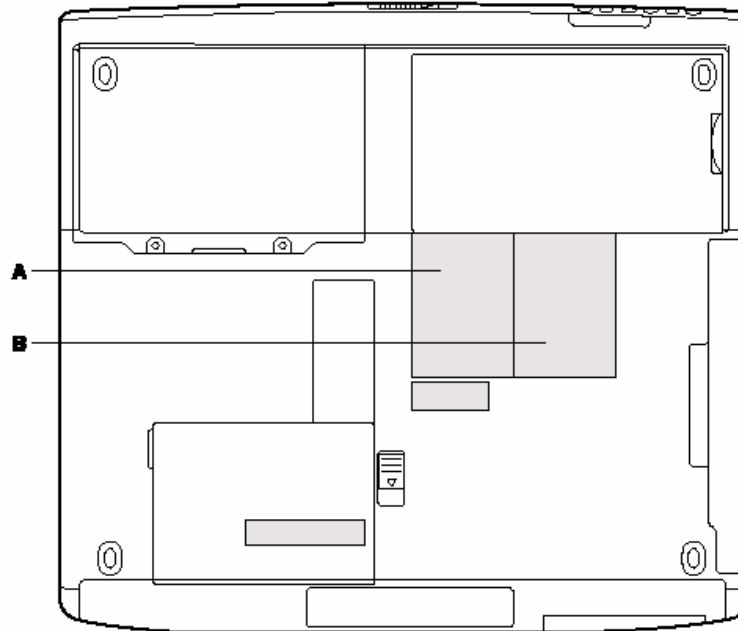

Label positions on the Portégé 4000

New labels

Refer to the figures above and below when you apply new labels.

1. If your computer has the Wireless LAN label at position A, apply the label shown in the following figure to position B.

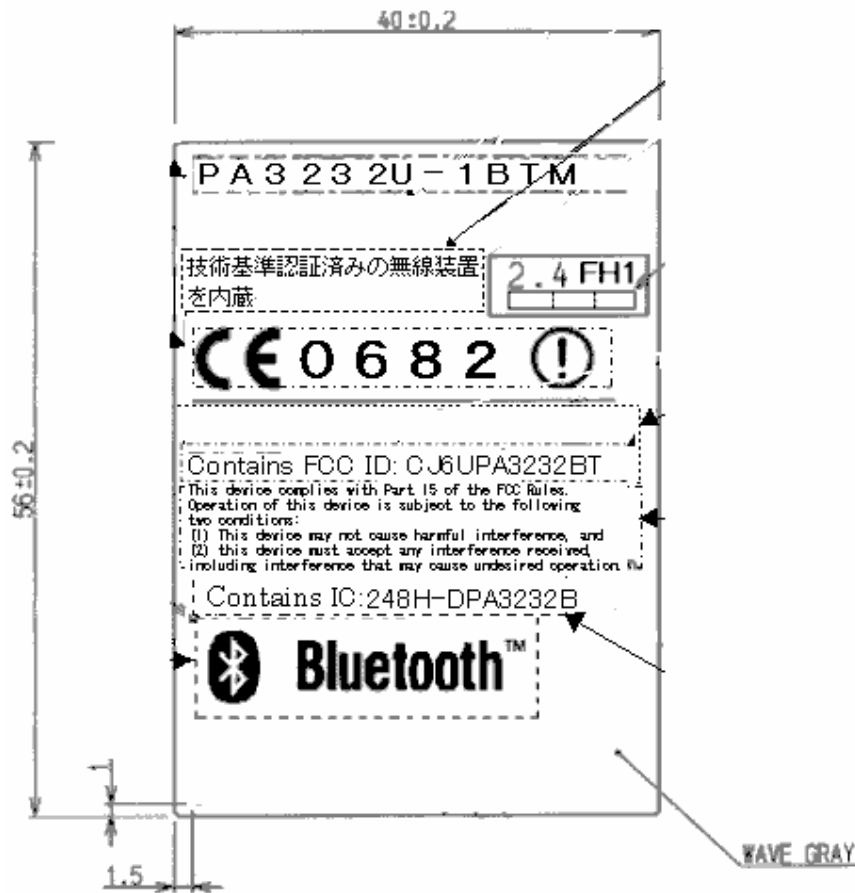

Bluetooth label



The asterisk in brackets represents a number. [5] indicates Tecra 9000, and [6] indicates Portégé 4000.