

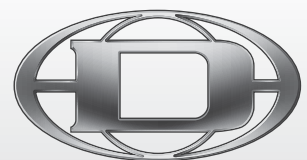

Loudspeaker Systems

MORE THAN 60 YEARS OF PRO AUDIO EXPERIENCE

Mobile Audio | Concert Sound | Fixed Installation | Pro Entertainment



DYNACORD
GERMAN ENGINEERING EXCELLENCE

Contents



INTRODUCTION

Contents	02 - 03
History	04 - 05
Milestones	06 - 07
Manufacturing	08 - 09
Bosch Production System	10 - 11



PRODUCTS

D-Lite Series	12 - 45
VariLine	46 - 61
CXM 15	62 - 64
AM 12	65
PowerMax 5	66 - 69
Xa 2 System	70 - 77
Cobra System	78 - 95
Alpha System	96 - 99



TECHNICAL SPECIFICATIONS

D-Lite Series	100 - 101
VariLine	102
CXM 15	103
AM 12	103
PowerMax 5	104
Xa 2 System	104
Cobra System	105
Alpha System	105



APPLICATIONS GUIDE

D-Lite Series	107 - 111
VariLine	111 - 114
PowerMax 5	114
Xa 2 System	115
Cobra-2 System	116 - 117
Cobra-4 System	117 - 119

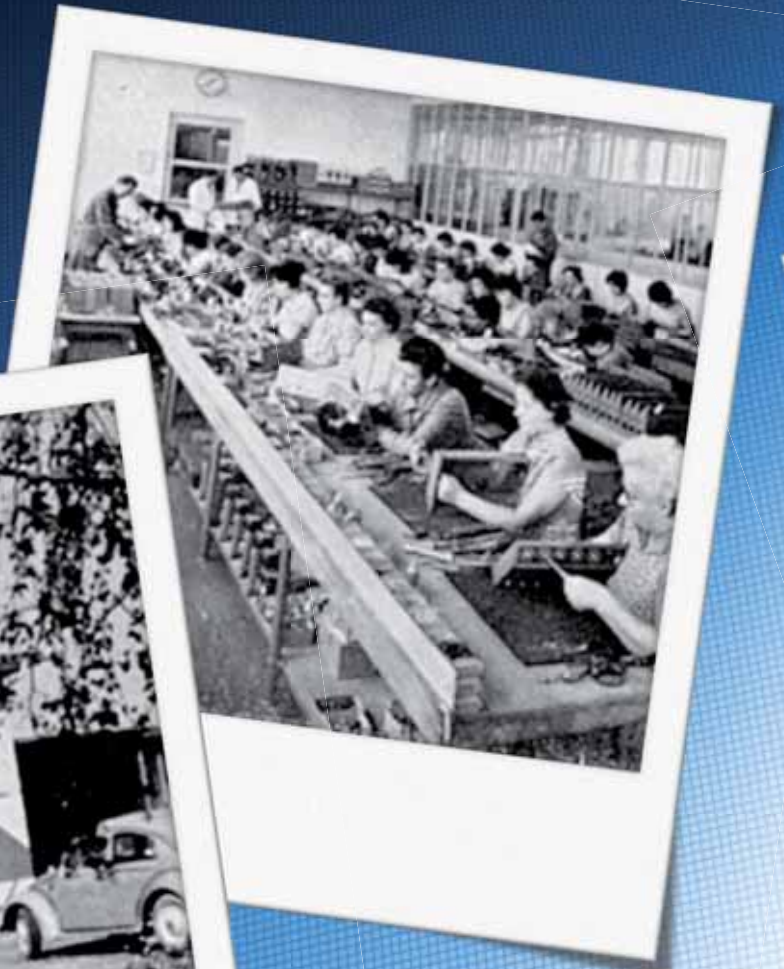

German Engineering Excellence

FOR MORE THAN 60 YEARS, DYNACORD HAS BEEN ONE OF THE MOST INNOVATIVE AND SUCCESSFUL MANUFACTURERS OF PROFESSIONAL AUDIO EQUIPMENT.



In 1945 Werner Pinternagel, who was an engineer, founded a workshop for the repair of radio devices in the Lower Bavarian town of Pilsting. The development and manufacture of audio amplifiers, which he began at the same time, became a particular passion.

These pioneering experiences formed the foundation for over 60 years of expertise in professional power amplifier technology — expertise upon which the brand DYNACORD is able to draw today. Early results included the KI cinema amplifier with its output of 25 watts. The devices of the company, which

in the meantime had moved to Landau and by then boasted a staff of four employees, still bore the brand name 'Dynaphon'.

From 1948 onwards, mixing and portable amplifiers bearing the name DYNACORD were being sold to an ever expanding circle of customers. Within a few years, the rapidly growing company had become one of the leading enterprises in the still young audio technology industry. Already in 1954, the manual workshop have given way to industrial production as the product portfolio continued to expand. The high-caliber, pioneering

and often visionary products have been presented ever since at all important international trade fairs and marketed successfully throughout the world. To make it possible to satisfy the enormous demand, DYNACORD moved to Straubing in 1958. The workforce, which at that time numbered 80 employees, continued to expand rapidly. Several times, the production facility was renovated or expanded.

Finally, in 1986 a new plant was opened in which more than 500 employees now develop, produce and dispatch the company's products to all corners of the globe.

Milestones

THE CONSTANTLY EXPANDING PRODUCT RANGE YIELDED MANY PRO AUDIO MILESTONES.



■ **A high degree of innovation, uncompromising quality, exceptional user-friendliness and truly legendary reliability and value retention have for over 60 years defined the brand DYNACORD.**

- the first generations of professional mixing amplifiers [Eminent, Gigant]
- the first tape-echo/reverb devices [Echocord]
- the first 'affordable' digital reverb device [DRS 78]
- the most advanced digital drums [ADDone, ADDtwo]
- the first professional digital reverb device based on 32-bit floating-point processing [DRP-20]
- the first processor power amplifiers with LPN filters [PCA series]
- one of the most successful power amplifiers in concert sound [L2400 / EV P3000]
- the first processor-controlled complete audio system [P3, P5]
- the first digital loudspeaker controller with graphic display of the acoustic system frequency response in the editing software [DSP 224 / 244 with CrossMax and EV Dx34 / 38 with RACE]
- the Planar Waveguide bass horns [F 18, Alpha B-3 and many others]
- the world's most powerful disco system [Alpha]
- the world's most successful powered mixer [PowerMate]
- the first stackable compact line array system [Cobra]
- the first Class H grounded bridge high-performance power amplifiers [PowerH]
- the unique IRIS-Net network software [incl. remote supervision, remote control of power amplifiers and digital audio matrices]
- the first digital power amplifiers with VLD-variable load drive [DSA Multi-Channel]



Echocord



DRS-78



PowerMate



Cobra



PowerH





Bosch Production System

QUALITY WITH SYSTEM

■ **With the introduction of the Bosch Production System (BPS) at the Straubing works, the brand DYNACORD is further enhancing its already legendary reputation for the highest production quality and reliability.**

Quality with system is assured by the BPS worldwide in all Bosch production centres, since absolutely identical indicators, equipment and processes are applied systematically throughout the enterprise. Decisions about which products to produce in which plant are primarily based on core areas of competence.

The same goes for the development. The first measures to guarantee quality are applied as early as the development phase of a product, where the 'thermal and mechanical stability', the 'secure functioning of the circuitry' and the demands of quality such as the acoustic performance and the product functions themselves are all ascertained in advance and rigorous tests conducted before any final decisions are taken about the design.

Decades of experience and the most modern quality management systems guarantee the extraordinary quality and legendary reliability of DYNACORD products.

Measurement Hall

PART OF THE NEW INVESTMENT INVOLVED THE CONSTRUCTION AND COMMISSIONING OF WHAT AT 600 SQUARE METRES IS ONE OF THE WORLD'S LARGEST AUDIO MEASUREMENT HALLS.



Manufacturing

■ Since September 2006, DYNACORD has belonged to the BOSCH concern's Security Technology department.

The production facility in Straubing has been considerably expanded and the work reorganized along the lines of the Bosch Production System (BPS). Part of the new investment involved the construction and commissioning of what at 600 square metres and 11 meters height is one of the world's largest audio



Manufacturing in Straubing, Germany



measurement halls. A reverberation time below one second allows for measurements under realistic conditions. One of the particular strengths of the brand DYNACORD is the fact that over the many years of its history profound know-how, covering the entire signal chain from the mixer to the loudspeakers has been acquired.

This advantage, coupled with its traditionally close relationship with users, has yielded many unique solutions to once-vexing problems and helped DYNACORD to develop a reputation the world over as a manufacturer of top-flight audio equipment on the absolute cutting edge of development.

■ **Additional capacity is available at the Bosch plant in Zhuhai, China, where the production also conforms to the BPS and quality controls are conducted using identical procedures and equipment.**



Manufacturing in Zhuhai, China





D-Lite Series

- D 8
- D 8A
- D 11A
- D 12 / D 12W
- D 12T / D 12TW
- D 12R / D 12RW
- D 12-3
- D 15-3
- Sub 112
- Sub 115
- Sub 118
- PowerSub 112
- PowerSub 212
- PowerSub 312
- PowerSub 315
- D-Lite 1000 System
- D-Lite 2000 System
- D-Lite **activeone**
- D-Lite **activetwo**
- D-Lite **activefour**

D-Lite Series

LOUDSPEAKER SYSTEMS

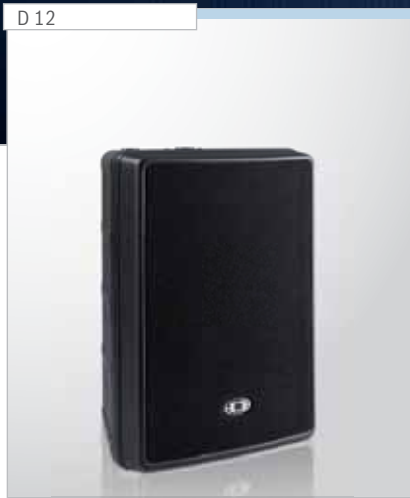
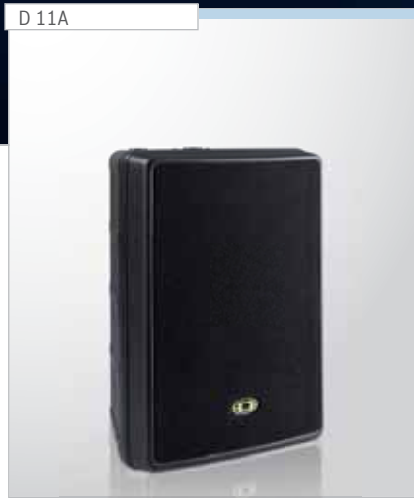



D 12T



D 12TW



D 12R



D 12RW



D 12-3



D 15-3

The full-range speakers of the D-Lite series are extremely light, mechanically durable polypropylene cabinets for professional portable and fixed installation sound reinforcement applications in small to medium-sized venues.

The wide range of mounting accessories available for the enclosures and their tasteful styling permit them to be used without problems in critical fixed installation applications. Being of polypropylene, the enclosures are capable of withstanding the roughest handling during transport and use. The integration

of the constant directivity HF horns into the baffle is CAD-optimized. The robust powder-coated steel grilles at the front of the enclosures are backed by black acoustic foam plastic. Both the Speakon sockets in the connection panels are recessed to allow the cabinets to be operated in cramped locations.

The beveled sides of the enclosures allow them to be used without problems in monitor applications in which more bass extension is required than that provided by typical monitor loudspeakers. Robust handles, integrated stand adapters, and a wide range of flying and mounting

accessories facilitate the transport and setting up of the enclosures as well as allowing them to be ideally positioned and aimed. Very powerful amplifiers can be used to achieve the widest possible dynamic range, as the loudspeakers of the D-Lite series offer very high power handling and are for the most part afforded additional reliable protection by the fully electronic Voice Coil Tracking Protection system, as well as halogen protectors against thermal overload. The internal passive crossovers are optimized for long throws and even dispersion, allowing D-Lite cabinets to be used under acoustically unfavorable conditions.

D-Lite Series

LOUDSPEAKER SYSTEMS



POWERSUB 315



■ **Suitable active and passive subwoofers implemented as vented direct-radiating enclosures permit flexible system configurations.**

The reflex systems of these subs, when compared with conventional bass reflex ports, are characterized by less flow loss and less wind noise. High sound pressure levels at very low frequencies are generated with considerably less distortion than is the case with conventional bass-reflex ports.

The passive varieties can, as a result of their integrated low-pass filters, simply be operated parallel to the various passive full-range boxes.

The active single-channel subs possess crossover outputs for the creation of active three-way systems with e.g. the models D 8A or D 11A. The three-channel subs already possess the requisite power amplifiers for passive tops and permit in the simplest manner the configuration of so-called 'satellite systems'.

D 8 and D 8W

FULLRANGE CABINET



The D 8 is a very compact, lightweight and mechanically very robust 8" / 1" two-way thermoplastic cabinet for professional sound reinforcement applications.



■ **It is remarkable in its class for the very high sound pressure levels it is capable of achieving as well as its outstanding audio performance.**

The wide range of mounting accessories available for the enclosure and its tastefully understated styling permit its convenient use even in critical applications in the fixed installation sector.

The housing is made from ABS and capable of withstanding the roughest handling during transportation and use. The D 8's bass

and midrange is the responsibility of the DND8200-8 low-distortion neodymium woofer. The integration into the baffle of the symmetrically radiating Constant Directivity high frequency horn, with its nominal radiation angle of 90° x 90° (horizontal x vertical) and Electro-Voice DH3 driver, is CAD-optimized.

With power handling of 250 W (rated) and 1,000 W (peak), a maximum SPL of 124 dB and a frequency range of 65 Hz - 20 kHz, the D 8 performs outstanding service not only as a full-range cabinet but also as the mid / high component of active and

passive satellite systems of superior quality. The crossover is optimized to achieve a long throw and a very even sound pattern, permitting the use of the D 8 even in unfavorable acoustic environments.

The loudspeaker components are guarded by thermo-switches and halogen protectors against thermal overload. The front is clad in black acoustic foam with a robust, powder-coated steel grille. The Speakon sockets on the connection panel are recessed. The enclosure is trapezoidal in shape, making it suitable also for monitoring applications.





D 8A

POWERED FULLRANGE CABINET

■ **The D 8A is the powered version of the D 8 offering integrated Class D power amplifiers, an electronic crossover and loudspeaker equalization.**

For the low and high frequency ranges, 2 x 200 W / RMS are available. The maximum overall amplifier output comes to 800 W IHF-A. The Line input is implemented as an XLR / jack combo socket. In addition, an XLR microphone input with a separate level control is available.

By means of the XLR Master Out socket, the mix of Line and Mic inputs can be looped through to additional powered cabinets.

For operation with powered subwoofers, a switchable low-cut filter is provided. The D 8A is notable for its high sound pressure level and a sonic image that remains free from distortion and discoloration even at the edges of its bandwidth.

It is ideal when combined with active subwoofers for the creation of very compact, active three-way high-powered systems for a multitude of applications in the live music, AV and fixed installation sectors.

The extensive range of optional accessories allows virtually unlimited use in fixed installations or flown configurations.



Distorsion-free, clear sound at peak levels



D 11A

POWERED FULLRANGE CABINET

■ **The D 11A is a conveniently equipped powered 12" / 1" full-range box offering integrated Class D power amplifiers, an electronic crossover and loudspeaker equalization.**

For the low and high frequency ranges 2 x 200 W / RMS are available. The maximum overall amplifier output comes to 800 W IHF-A. The Line input is implemented as an XLR / jack combo socket. Via the Line Thru XLR socket, the signal can be looped directly through to additional powered cabinets. The

controllable Stereo-Aux channel with RCA / cinch sockets permits e.g. the direct connection of CD or MP3 players.

In addition, an XLR microphone input with a separate level control is available. By means of the XLR Master Out socket, the mix of Line, AUX and Mic inputs can be looped through to additional powered cabinets. For operation with powered subwoofers, a switchable low-cut filter is provided. The D 11A is notable for its high sound pressure level and a sonic image that

remains free from distortion and discoloration even at the edges of its bandwidth.

When combined with powered subwoofers, ultra-compact active three-way high powered systems can be created very simply for a multitude of applications in both the live music and fixed installation sectors.

The extensive range of optional accessories allows virtually unlimited use in fixed installations or flown configurations.



D 12 · D 12W · D 12T · D 12TW · D 12R · D 12RW

FULLRANGE CABINETS

Weighing a mere 16 kg, the D 12 two-way full-range cabinet with its polypropylene enclosure has an extremely linear frequency response and is notable for its powerful, natural reproduction of the voice as well as its transparent resolution throughout

the entire frequency range. Its elegant styling and tasteful black or white finishes make it suitable for a very wide range of small to medium-sized events as well as critical applications in the fixed installation sector.



■ The 12" DL 12 BFH high-power transducer covers the bass and midrange up to 1.5 kHz, whilst in the high-frequency range, an ND-2 neodymium driver is coupled with a large-format constant Q horn with an 80° x 40° coverage pattern, the integration of which into the baffle is CAD-optimized.

As with all the D-Lite cabinets, protection by halogen bulbs, allow for high, distortion-free peak

sound levels can be generated, and professional power amplifiers can be used the rated outputs of which are the same as the peak values of the enclosures they are driving without the reliability of either being compromised.

Whether used solo as a full-range box or in combination with passive subwoofers, power amplifiers from the SL or LX series are recommended, as is the PowerMate. With

its ultra-low-distortion toroidal core transformer, the D 12T is designed for 100 V audio networks, whilst the D 12R is a low-impedance, weather-resistant installation version with an integrated PG cable.

Like the D 12, the D 12T and D 12R are available in both black and white. The extensive range of optional accessories allows their virtually unlimited use in fixed installations or flown configurations.



D 12-3

FULLRANGE CABINET

■ DYNACORD's traditional and popular 12" / three-way concept experiences a further dramatic improvement in performance with the introduction of the D 12-3.

With its voluminous bass reproduction and its uncolored, extremely low-distortion vocal reproduction, combined with its transparent resolution throughout the entire frequency range, this lightweight full-range satellite stands head and shoulders above the multitude of other enclosures on the market made from synthetic materials. The tried-and-tested DL 12 BFH low frequency driver,

with its high power handling, transduces the frequency range below 700 Hz.

The midrange is handled by an extremely low-distortion DYNACORD DND 6120 neodymium MF driver, whilst a DH-3 coupled with a 90° x 50° constant-directivity HF horn delivers transparent reproduction of all frequencies above 4 kHz.

Thanks to the extremely broad (> 120°) conical dispersion pattern in the midrange, even in acoustically unfavorable venues it is generally unnecessary to go to great lengths to aim the en-
closures precisely at the areas to be covered.

Whether the D 12-3 is used as a full-range box or in combination with passive subwoofers with integrated hi-cut filters, such as the Sub 115 or Sub 118, the PowerMate 1000 / 1600 or power amplifiers from the SL or LX series are the ideal partners. The Voice Coil Tracking Protection system combines with halogen protectors to provide the loudspeakers with reliable protection against thermal overload.

The extensive range of optional accessories allows virtually unlimited use of the cabinet in fixed installations or flown configurations.



Uncolored, extremely
low-distortion vocal reproduction



D 15-3

FULLRANGE CABINET

■ 15-3 designs are among the classics of pro audio history.

With just such a design to which an ultra-modern twist has been added, the D 15-3 sets new standards in the area of professional polypropylene enclosures, reconciling the highest possible sound pressure levels, maximum power handling and linear frequency response with modest dimensions and extreme lightness. Equipped with a DYNACORD DND 15400 neodymium loudspeaker capable of high power handling, the D 15-3 convinces with its powerful and natural voice reproduction and impressive sub bass.

For the midrange, an extremely low-distortion DYNACORD DND 6120 neodymium loudspeaker is used, which with its conical 120° dispersion guarantees uncolored reproduction of vocals and freedom from alignment problems. The integration into the baffle of the constant directivity high-frequency horn, which has a nominal dispersion angle of 90° x 50°, is CAD-optimized, whilst the DH-3 HF driver provides transparent reproduction of the high frequencies.

The Voice Coil Tracking Protection system combines with halogen protectors to provide the loudspeakers with reliable protection

against thermal overload. The extensive range of optional accessories allows virtually unlimited use of the cabinet in fixed installations or flown configurations.

In addition to delivering excellent results in its role as a pure, full-range box, the D 15-3 can also be connected directly to a passive subwoofer with an integrated hi-cut filter, such as the Sub 118, and run in parallel, in which case no additional amplifier is required. The ideal drivers for full-range or full-range / sub combinations are the professional power amplifiers of the DYNACORD SL and LX series or the PowerMate.



15-3 DESIGNS ARE AMONG THE CLASSICS OF PRO AUDIO HISTORY.





Sub 112

SUBWOOFER

■ **The DYNACORD Sub 112 is a vented, direct-radiating cabinet equipped with a high-power DYNACORD DND12S400 neodymium woofer boasting power handling of 400 W (rated) and 1600 W (peak).**

The conical vent system results in less flow loss and lower air noise than conventional vented designs. High sound pressure levels are also generated at low frequencies with significantly less distortion than by conventional bass reflex vents. The Sub 112 contains a passive low-pass filter with a slope

of 6 dB / octave. The Sub 112 can therefore be used directly in parallel to appropriate full-range cabinets, e.g. the DYNACORD D 8, if extended bass reproduction is required.

The Sub 112 cabinet is composed of birch plywood 15 mm-thick. All corner joints and braces are grooved and glued. The cabinet's surface is painted with a robust, dual component lacquer finish. The acoustic foam and powder coated steel grille at the front protect the DND12S400 woofer from harm during transportation

and against the depredations of inclement weather. The connection panel offers two 4-pin Speakon sockets (INPUT / THRU) for a more secure connection and the easy daisy-chaining of cabinets. A threaded pole adapter is recessed in the top of the Sub 112 cabinet for the swift and safe pole-mounting of suitable full-range cabinets. The cabinet is equipped with four large rubber feet for greater stability. Two handles on the side make it possible to carry the device easily and safely.

A hard-wearing protective cover is available as an optional accessory.



Sub 115 and Sub 118

SUBWOOFER

The Sub 115 is a vented direct-radiating enclosure with an Electro-Voice EVS 15S woofer, which offers high power handling.

As a reflex system the High-Speed Laminar Vent (HSLV) is used. Compared to conventional bass reflex vents, airflow loss and air noise are considerably reduced by HSLV technology. High sound pressure levels can be generated at low frequencies with considerably less distortion than is possible with conventional bass-reflex designs.



■ Like almost all the loudspeakers of the D-Lite series, the 15" / 18" subwoofers, too, are reliably protected against thermal overload by the fully electronic Voice Coil Tracking Protection system and halogen protectors respectively.

Extremely powerful amplifiers can therefore be used to achieve the widest possible dynamic range,

without any thermal overloading of the voice coils. Instead of a disruptive shutdown like those produced by conventional safety circuits, VCTP implements a gentler reining-in of the power to safe limits („soft switching“) whenever any overloading occurs.

For universal use in combination with full-range tops such as the D 12,

D 12-3 or D 15-3, the Sub 115 and Sub 118 are equipped with hi-cut filters to allow their simple and unproblematic connection in parallel with the tops.

The Sub 115 has the same styling and footprint as the active 3-channel PowerSub 315 and is therefore the ideal choice to give powerful emphasis to the bass in active systems.



Sub 115 and Sub 118

SUBWOOFER

■ Like the Sub 115, the Sub 118 is implemented as a direct-radiating vented subwoofer with a High-Speed Laminar Vent.

Offering extremely high power handling (700 W RMS and 2800 W peak power), the DYNACORD LFS 18700 low frequency driver generates a powerful and distortion-free bass foundation that reaches all the way down to 30 Hz and generates sound pressure levels as high as 132 dB.

The enclosures of both subwoofers are made from birch multiplex with a durable dual-component coating. The upper bowl handle contains an integrated M 20 screw to accommodate a mounting pole.

Suitably equipped full-range cabinets can therefore be mounted directly above the subwoofers with a consequent saving of space. The enclosures are equipped with eight large feet, four robust casters on the back, and ergonomically designed bowl handles to ensure easy transportation and safe setting-up.



PowerSub 112

POWERED SUBWOOFER



■ The PowerSub 112 is the ideal bass extension for powered full-range cabinets such as the D 8A.

It is very light and despite its extremely compact dimensions provides a very powerful and deep bass foundation. The vented design gives the PowerSub 112 a very musical,

tight and voluminous sound, quite unlike that of the band-pass solutions widely encountered in this product class. The Class D power amplifier module delivers 200 W RMS / 400 W IHF-A and is equipped with an integrated crossover with a Mid / High output. The polarity can be reversed should other system components require it.





PowerSub 212

POWERED SUBWOOFER



■ **The PowerSub 212 is an extremely compact, high-powered subwoofer with 2 x 12" drivers and a 2 x 200 W RMS / 2 x 400 W IHF-A Class D power amplifier.**

The integrated stereo crossover also supports the creation of active three-way systems with mono sub and active full-range cabinets (see System Combinations below).

The PowerSub 212 is the ideal partner for devices like the D 8A or D 11A and convinces with a deep bass foundation and very high sound pressure levels. As is the case with the PowerSub 112, the reproduction remains clean and distortion-free even at the edges of its bandwidth. Four smooth-running casters are provided for easier transportation.



PowerSub 312

POWERED SUBWOOFER

■ **The PowerSub 312 powered 12" subwoofer, which is equipped with an integrated three-channel Class D power amplifier with a total output of 1300 W / RMS, was specially conceived to permit the swift and simple creation of a subwoofer satellite system.**

As satellites, two passive loudspeaker systems such as the DYNACORD D 8 are needed. You only need to connect them to the Speakon outputs provided for the purpose. The „X-Over“ switch offers a choice of three discrete frequencies for the crossover between the subwoofer and the satellites: 70 Hz, 100 Hz and 140 Hz, whilst the „Sub Level“ control allows you to adjust the output of the PowerSub 312 in the range from -8 dB to +10 dB. The PowerSub 312 is made from multiplex birch plywood and capable of withstan-

ding the toughest challenges during transportation as well as in use. The integrated lightweight 800 W + 2 x 250 W digital power amplifier is perfectly attuned in every respect to the integrated DYNACORD DND 12S400 woofer to maximize the dynamic range and audio quality and ensure that the woofer is invariably driven within its optimum working range.

To provide further assurance that these operating limits are respected, the performance is supervised by additional protective circuitry such as voice coil protection, DC / HF protection, audio limiters, back EMF protection and thermal protection. Together these ensure that even when the most extreme demands are placed upon the system under the most unfavorable conditions, the PowerSub 312 continues to

operate flawlessly. The use of „Class D Digital Technology“ ensures that there is considerably less power dissipation than in normal Class AB designs. The thermal load on the components is therefore markedly reduced.

The enclosure is coated with 2K lacquer, which is extremely scratch-resistant and proof against rough handling during transportation. A robust, powder-coated steel grille protects the woofer against mechanical damage. All the control elements are recessed to provide optimal protection of the PowerSub 312's most sensitive parts even during transportation. For greater carrying comfort, the enclosure is furnished with two sturdy handles, whilst an integrated threaded pole adaptor allows you to make optimal use of precious space on stage.



- active two-way Class D amplification
- 1000 W Sub + 2x 500 W Top
- switchable crossover frequencies
- High-Speed Laminar bass-reflex design
- LFS 1008 high-power woofer
- external subwoofer output
- Voice Coil Tracking Protection



PowerSub 315

POWERED SUBWOOFER

■ **The PowerSub 315 is an powered vented subwoofer featuring the novel High-Speed Laminar Vent design.**

Weighing a mere 45 kg, the light-weight enclosure accommodates all the electronics and audio processors in addition to the switchable stereo crossover (80 Hz / 100 Hz / 160 Hz) and four Class D power amplifier blocks delivering a combined output of 2000 W.

This is the ideal centerpiece for a high-powered satellite system. Two bridged blocks provide the

integrated 15" DYNACORD LFS 1008 subwoofer with a total of 1,000 W (RMS) / 8 Ω and 2 x 500 W (RMS) / 4 Ω are made available to the connected satellites.

The subwoofer level is continuously adjustable and you can select between three different sub / satellite crossover frequencies ranging from 80 Hz to 160 Hz. To provide particularly powerful reinforcement of the low frequency range, two passive (e.g. DYNACORD Sub 115) subwoofers can be driven by the PowerSub 315. In this mode, the integrated sub power amplifiers

are switched over from 1 x 1000 W / 8 Ω to 2 x 500 W / 4 Ω. In a fully-expanded system, the PowerSub 315 can drive a total of four 8 Ω satellites and an additional two passive 8 Ω subwoofers without any difficulty.

Packed in an extremely robust but compact multiply birch multiplex enclosure with castors included in the delivery, the PowerSub 315 offers easy transport and safe handling. An M20 threaded adapter for a mounting pole is integrated into the bowl handle on top of the subwoofer.

D-Lite 1000

SYSTEM



System components:

- 2 x D 8
- 1 x PowerSub 312

■ **The D-Lite 1000 system is a convincing answer to the central demand of entertainers, mobile DJs, smaller bands and other users of mobile audio systems, which is for a system that is as compact as possible and as light as possible but capable nonetheless of delivering uncompromised audio performance.**

With a total weight of less than 45 kg and fitting easily into the tiniest of car boots, the D-Lite 1000 system provides a typically well thought-out, „It's a DYNACORD“ solution to a long-felt need.

In the ultra-compact class, this system offers exemplarily high sound pressure levels, a substantial long throw capability, and broad, even coverage. At the same time, it achieves brilliantly clear reproduction with extremely low distortion and

therefore a very high level of intelligibility – even in locations with notoriously problematic acoustics. A particularly convincing feature is the exceptionally powerful bass reproduction, which reaches all the way down to 43 Hz.

The integrated lightweight 800 W + 2 x 250 W digital power amplifier is perfectly tuned in every respect to the system and also permits the connection of two additional D 8 satellites (for example) and a passive Sub 112 as a bass extension. Many and various safety circuits – such as Voice Coil Protection, DC / HF protection, audio limiter, back EMF protection and thermal protection – guarantee optimum operating security. With these characteristics, the System D-Lite 1000 is also an extremely attractive solution for many fixed installation applications



D-Lite 2000

SYSTEM

System components:

- 2 x D 12
- 1 x PowerSub 315

■ **The D-Lite 2000 system has been specially designed to meet the various needs of solo entertainers, mobile DJs and small bands.**

Easy handling – thanks to the ultra-compact and lightweight construction of the enclosures – and powerful, transparent sound with loads of headroom combine to raise the

D-Lite 2000 to the pinnacle of excellence among professional satellite systems. The basic D-Lite 2000 system, comprising a PowerSub 315 and two D 12 full-range satellites, is designed to be easily expandable, so you can't go wrong when it's time to buy in more power. Up to four satellites (two per side) and two additional passive subwoofers can be driven efficiently and easily by

the mighty PowerSub 315. The D-Lite 2000 system is also the ideal solution for fixed installation in a wide variety of catering establishments such as restaurants, cafes, bars and pubs as well as in schools. A comprehensive assortment of installation hardware is available for positioning the satellites, including mounting yokes, wall brackets and truss rigging gear.

Active three-way system combinations



Extremely compact self powered 3-way systems can be set up very easily by using the powered top cabinets together with the powered subs featuring built-in crossovers. This configuration meets even the highest demands of sound quality and intelligibility.

D-Lite **activeone**

ACTIVE THREE-WAY SYSTEM

■ D-Lite **activeone**, featuring one mono double 12" subwoofer for smaller applications.

System components:

- 2 x D 8A
- 1 x PowerSub 212



D-Lite **activetwo**

ACTIVE THREE-WAY SYSTEM

■ D-Lite **activetwo**, featuring two single 12" subwoofers for small to mid-sized venues.

System components:

- 2 x D 8A
- 2 x PowerSub 112



D-Lite **activefour**

ACTIVE THREE-WAY SYSTEM

■ D-Lite **activefour**, featuring two double 12" subwoofers for bigger venues.

System components:

- 2 x D 11A
- 2 x PowerSub 212



Accessories

D-Lite SERIES

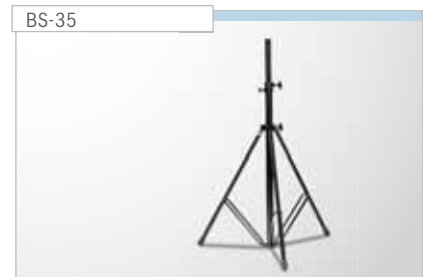
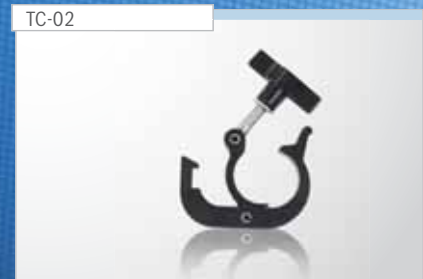
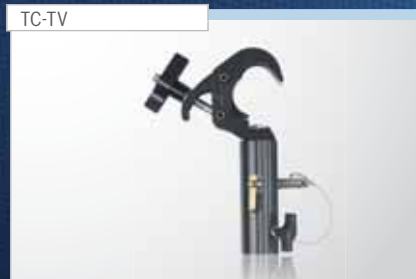

ACCESSORIES

Top	D 8 D 8W	D 8A	D 11A	D 12 D 12 W	D 12T D 12TW	D 12R D 12RW	D 12-3	D 15-3
Color	Black White	Black	Black	Black White	Black White	Black White	Black	Black
Dust Cover SH...	SH-D 8 F01U119025		SH-D 12 F01U118994				SH-D 15 F01U119006	
F 212 Monitor Feet	---		F01U100802				---	
MB D 8 UMH U-Bracket	MB D 8 UMH / F01U119020 MB D 8W UMH / F01U119034		---				---	
MB 212 U-Mounting Bracket	---		MB 212 / F01U100804 MB 212W / F01U100828				---	
MB 312 Horiz. Cluster Plate	---		MB 312 / F01U100805 MB 312W / F01U100829				---	
MB 112 Eyebolt-Set M 8 **	---		F01U100803				---	
** MB 112 must only be used together with MB 212 due to safety reasons!								
MB 200 UMH U-Bracket	---		F01U120157				---	
MB 500 UMH U-Bracket	---		---	---	---	---	---	F01U119008
FB... Flying Bracket	FB-D 8 F01U119021		---	---	---	---	---	FB-D15 F01U119009
FB-TV TV-Spigot	F01U100845		---	---	---	---	---	F01U100845
TC-TV Truss > TV-Spigot	F01U100727		---	---	---	---	---	F01U100727
PM-TV PoleMount > TV-Spigot	F01U100728		---	---	---	---	---	F01U100728
WMK-10 Wall Mount Kit	WMK-10 / F01U119022 WMK-10W / F01U119032		---	---	---	---	---	---
TMA Tilt angle for UMH					TMA / F01U118977 TMA W / F01U119038			
RMA Rotatable Kit for UMH					RMA / F01U118976 RMA W / F01U119039			
TC-02 Truss clamp for UMH					F01U100657			
PCL-M10 Pole Mount	F01U100833		---	---	---	---	---	F01U100833
Speaker Stand max. 50 kg					BS-35 / F01U141046			

Sub	Sub 112	Sub 115	Sub 118	PowerSub 112	PowerSub 212	PowerSub 312	PowerSub 315
Dust Cover SH...	SH-SUB 112 F01U119033	SH-315 F01U118995	SH-118 F01U119007	SH-SUB 112 F01U119033	SH-PS 212 tba.	SH-SUB 112 F01U119033	SH-315 F01U118995
PCL 880 Pole Mount fix 880mm					F01U100601		
VPM 1500 Pole Mount adjustable					F01U141047		



VariLine

- VL 62 / VL 62W
- VL 262 / VL 262W
- VL 122
- VL 152
- VL 212
- SUB 18
- SUB 28

VariLine

MULTIFUNCTIONAL SPEAKER LINE





Professional sound reinforcement requires maximum performance and high sound pressure levels for a wide variety of touring and installation applications.

Universal loudspeaker functionality is therefore especially important, making it possible to react without difficulty to changing demands. Both acoustically and mechanically, VariLine enclosures have

been designed and optimized without compromise for multifunctional applications. Innovative protective circuits guarantee maximum reliability and optimal safety for all loudspeaker components.

Engineered and made in Germany, VariLine loudspeakers employ only the finest components, including lightweight high-power neodymium transducers, rotatable CAD-optimized CD horns, fully-electronic

loudspeaker protective circuitry and passive true-phase crossovers that ensure linear reproduction even in critical acoustic environments.

Comprehensive mounting and rigging accessories facilitate professional handling and simple, secure installation of VariLine loudspeakers. Stylish and yet visually unobtrusive, these enclosures harmonize with the most elegant interiors.

Components

VariLine

CROSSOVERS



■ Throughout the VariLine series, only selected components of the highest quality are used.

These include not only the crossovers and signal processors but also DYNACORD's innovative protective circuits: the individual loudspeaker components are safeguarded from thermal overload by the all-electronic Voice Coil Tracking Protection system as well as halogen protectors. VariLine loudspeakers can therefore be driven by extremely powerful amplifiers to obtain the widest possible dynamic range without their voice coils sustaining damage – even when operating errors occur. Furthermore, any thermal overload triggers a 'soft' power reduction, free from the distracting switching noise that is the bugbear of conventional protective circuits. The 12" and 15" models offer the additional option of switching to active two-way operation.

HORNS



■ The large-format VariLine constant directivity HF horns have been optimized using advanced CAD software and can be rotated through 90° for horizontal applications.

As well as exemplarily low distortion, these horns are remarkable for the very low frequencies at which they retain their directivity. The smaller enclosures are equipped with Electro-Voice DH3 titanium domes, whilst the VL 122 and larger models feature Electro-Voice ND6 neodymium drivers with 3" voice coils and 1.4" exits. These advantageous horn / driver configurations provide crisp and powerful high-resolution HF reproduction.

CONSTRUCTION



■ VariLine enclosures are made from extremely rugged, multiply birch with a dual-component finish sufficiently resilient to withstand the roughest of handling on the road and on stage.

The front is protected by a sturdy powder-coated steel grille lined with high quality acoustic foam. The logo can be rotated through 90° and therefore looks right whether the enclosures are mounted vertically or horizontally. The 12" and 15" enclosures are asymmetric, which not only optimizes them for floor monitoring but also facilitates the creation of clusters.

LOUDSPEAKERS



■ VariLine loudspeakers are equipped with extremely low-distortion, state-of-the-art drivers that provide not only a linear frequency response but also a wide dynamic range and high power handling.

The 6", 12" and 15" transducers are armed with neodymium magnets – which, incidentally, contributes significantly to the exceptional lightness of VariLine cabinets.

INSTALLATION HARDWARE



■ A wide range of installation hardware is available for VariLine fullrange cabinets providing classic three-point eyebolt hanging, wall or ceiling bracket mounting and, even more convenient, three-level adjustable mounting.

FLYING BRACKETS



■ Flying brackets are optional accessories for precise loudspeaker aiming at the listening areas.

In installation applications, the bracket can be equipped with truss clamps for flying while an adapter enables stand mounting. A TV spigot enables easy changing from truss to stand mounting while additional adapters provide maximum flexibility for a comprehensive range of applications.

OPTIMIZED FACTORY PRESETS INCLUDING FIR-TUNE LINEARIZATION ARE AVAILABLE FOR DSP 600, P 64 AND PowerH AMPLIFIERS WITH RCM-26 UNDER IRIS-NET.



- *top quality sound reinforcement for speech and music*
- *theater front fill*
- *multimedia applications*
- *satellite and delay systems*



VL 62 and VL 262

TWO-WAY FULLRANGE CABINETS

■ **The models VL 62 and VL 262 are extremely compact, two-way fullrange cabinets suitable for a wide variety of mobile and installation applications.**

Their very high sensitivity (94 dB / 97 dB @ 1 W / 1 m) and power handling make them stand out in their class.

Extremely low-distortion DND 6130-16 neodymium drivers transduce the low frequencies and midrange,

while a 90° x 40° HPT94 constant directivity horn handles everything above. This is driven by Electro-Voice's brilliant and clean DH3 titanium dome and can be rotated easily through 90° when the cabinets are operated in a horizontal position.

Recessed Speakon connectors enable the VL 62 and VL 262 to be placed close to walls. Two M10 threaded inserts in the side of the VL 262 are provided for the FB VL 262 bracket, which allows the cabinet

to pivot on both the vertical and horizontal axes.

MB and MB UMH brackets can be attached to the top or bottom using the two M10 threaded inserts provided, whilst four M6 threaded inserts are provided on the back for conventional wall-mounting brackets.

A robust and hard-wearing, water-repellent cover is available as an accessory.



VL 122, VL 152 and VL 212

HIGH-POWER TWO-WAY CABINETS

- *top quality sound reinforcement for speech and music*
- *high powered monitoring*
- *front and side fill*
- *club systems with subwoofers*
- *delay systems*

■ **The 12" and 15" VariLine models are high-power, two-way cabinets equipped exclusively with high-quality neodymium components.**

They are also remarkably light for their class. Also notable are their very high power handling capacity, low distortion and impressive maximum SPL. Large format HF horns with Electro-Voice ND6 drivers provide balanced directivity well below the crossover frequency and clear, detailed HF reproduction. In horizontal applications – especially when used as monitors and in high-quality installations – the radiation of the midrange and higher frequencies can be optimized by rotating the horns.

The 12" and 15" models can be used in full-range mode or switched to active two-way operation. Their asymmetrical enclosure design is ideal for floor monitor use as well as for cluster arrangements.

An extensive range of mounting and flying hardware is available: see page 60 - 61.





SUB 18 and SUB 28

SUBWOOFER

■ **The vented SUB 18 and SUB 28 direct radiators have been designed for subwoofer use in active multi-way systems.**

The superior transient response of the classic bass reflex construction also makes them suitable for medium to large bass arrays.

The premium 700 W RMS long-excursion woofers boast extremely low THD, and the reliable, all-electronic Voice Coil Tracking Protection prevents thermal overload of the 100 mm sandwich voice coils.

For maximum dynamics, the Sub models can be driven by extremely powerful amplifiers; thermal overload triggers a virtually inaudible 'soft' power reduction.

The 18 mm multiply birch enclosures feature a rugged dual component structured finish. The woofers are protected against damage and inclement weather by a sturdy powder-coated steel grille lined with high quality acoustic foam. Wheel kits with four 100 mm factory-assembled 'Blue Wheels' are available as options.





These are mounted on the back to provide easy and convenient transport.

The SUB 28 is switchable between 1 x 4 Ω and 2 x 8 Ω operation, in which case the signal for Subwoofer A is on pins 1+ / 1-, and that for Subwoofer B on pins 2+ / 2-, of the Speakon connectors.

When driven by DYNACORD SL, LX or PowerH series amplifiers, a single four-pole cable connected to Channel A is all that is needed to drive both woofers.



SUB 18 and VL 122

SYSTEM



■ **A combination with a high power handling capacity in active two- or three-way operation providing suitable sound reinforcement for small to medium-sized venues such as bistros and clubs.**

FB-VL122 flying brackets make it possible to aim the satellites

precisely at the coverage area and they can be pole-mounted directly on top of the subwoofers to save space.

As drive units, high-powered amplifiers from LX series combined with the DSP 600 controller or else PowerH amplifiers with RCM-26 modules are recommended.

OPTIMIZED FACTORY PRESETS INCLUDING FIR-TUNE LINEARIZATION ARE AVAILABLE FOR DSP 600, P 64 AND PowerH AMPLIFIERS WITH RCM-26 UNDER IRIS-NET.



SUB 28 and VL 212

SYSTEM

■ **A combination with a high power handling capacity in active two- or three-way operation.**

Ideally suited to use as a front-of-house PA system in medium-sized venues calling for maximum sound pressure in the low-mid frequency

range. Each loudspeaker is reliably protected against thermal overload by its own all-electronic Voice Coil Tracking Protection circuit, which makes possible the use of extremely powerful power amplifiers from DYNACORD's PowerH series, such as the H 2500 or H 5000, to

OPTIMIZED FACTORY PRESETS INCLUDING FIR-TUNE LINEARIZATION ARE AVAILABLE FOR DSP 600, P 64 AND PowerH AMPLIFIERS WITH RCM-26 UNDER IRIS-NET.



Accessories

VARILINE

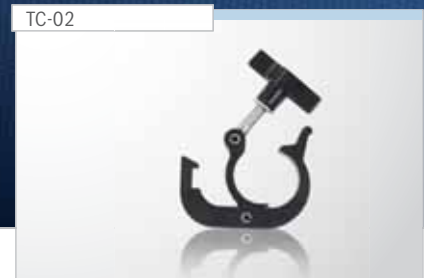

ACCESSORIES

Top	VL 62	VL 62W	VL 262	VL 122	VL 152	VL 212
Color	Black	White	Black	Black	Black	Black
Dust Cover SH...	SH-VL 62 F01U119026	SH-VL 62 F01U119026	SH-VL 262 F01U119017	SH-VL 122 F01U119018	SH-VL 152 F01U119019	SH-VL 212 F01U119028
EBK M10	EBK M10 F01U100849	EBK M10 F01U100849	EBK M10 F01U100849	EBK M10 F01U100849	EBK M10 F01U100849	EBK M10 F01U100849
WMK-10 Wall Mount Ki	WMK-10 F01U119022	WMK-10W F01U119032	WMK-10 F01U119022	---	---	---
MB ... U-Mounting Bracket	MB 62 F01U119023	MB 62W F01U119036	---	---	---	MB-VL 262 F01U119031
MB UMH U-Bracket	---	---	MB 262 UMH F01U119014 MB 262W UMH F01U119037	MB 122 UMH F01U119015	MB 152 UMH F01U119016	
TMA Tilt angle for UMH	---	---	TMA F01U118977 TMA W F01U119038	TMA F01U118977 TMA W F01U119038	TMA F01U118977 TMA W F01U119038	---
RMA Rotatable Kit for UMH	---	---	RMA F01U118976 RMA W F01U119039	RMA F01U118976 RMA W F01U119039	RMA F01U118976 RMA W F01U119039	---
TC-02 Truss clamp for UMH	TC-02 F01U100657	TC-02 F01U100657	TC-02 F01U100657	TC-02 F01U100657	TC-02 F01U100657	---
FB... Flying Bracket	FB-VL 62 F01U119024	FB-VL 62 F01U119024	FB-VL 262 F01U119011	FB-VL 122 F01U119012	FB-VL 152 F01U119013	FB-VL 212 F01U119030
PCL M10 Pole Mount	PCL M10 F01U100833	PCL M10 F01U100833	PCL M10 F01U100833	PCL M10 F01U100833	PCL M10 F01U100833	PCL M10 F01U100833
FB-TV TV-Spigot	FB-TV F01U100845	FB-TV F01U100845	FB-TV F01U100845	FB-TV F01U100845	FB-TV F01U100845	FB-TV F01U100845
TC-TV Truss > TV-Spigot	TC-TV F01U100727	TC-TV F01U100727	TC-TV F01U100727	TC-TV F01U100727	TC-TV F01U100727	TC-TV F01U100727
PM-TV PoleMount > TV-Spigot	PM-TV F01U100728	PM-TV F01U100728	PM-TV F01U100728	PM-TV F01U100728	PM-TV F01U100728	PM-TV F01U100728





Monitor Speakers

- CXM 15 / CXM 15W
 - AM 12
-

CXM 15 / CXM 15W

COAXIAL MONITOR SPEAKER CABINET

- Coaxial Monitor 15" / 1.4" 2-Way
- 102 dB SPL / 1 W / 1m
- Max. 135 dB SPL / 1 m
- Light Weight 19 kg
- Switchable to Biamp Mode
- FIR and IIR Presets available



■ **The DYNACORD CXM 15 is a lightweight wedge for professional monitoring applications. The DYNACORD DCX15450 two-way 15" / 1.4" transducer uses a coaxially mounted HF unit and can be used in passive or bi-amped operating mode.**

The acoustic crossover frequency between the 15" low-frequency transducer and the 1.4" mid-high compression driver is at 1.2 kHz. The slope of the built-in passive crossover network is 12 dB / octave. Extremely precise vocal definition is assured by the comparatively low crossover frequency and the coaxial transducer design. Power amplifiers are connected to the CXM 15 via Speakon NL4MPR

connectors. The pin assignment in passive mode is 1+ / 1-. Switching from passive mode to bi-amped mode is performed by operation of a slider switch. In bi-amping mode, pins 1+ / 1- are connected to the 15" low frequency section of the CXM 15 and pins 2+ / 2- to the 1.4" mid-high-frequency section.

The CXM 15 is equipped with three Speakon sockets switched in parallel. This simplifies the daisy-chaining of multiple wedges and pole-mounted CXM 15 cabinets. The 1.4" MF/HF compression driver is safeguarded against thermal overload by the fully-electronic Voice Coil Tracking Protection system, which exhibits „soft“ switching characteristics, sparing audiences the annoying

clicks and pops that are the bugbear of conventional solutions. Both FIR and IIR presets are available for a wide variety of operating modes. The CXM 15 is constructed from birch plywood and therefore extremely resistant to abuse on the road. All cabinet connections are slotted and glued. The surface is protected by a hard-wearing textured finish.

A powder-coated steel grille backed by acoustic foam protects the loudspeaker components from accidental damage. A recessed adapter is provided to facilitate pole-mounting. Handles have been integrated into both sides of the CXM 15.

A version of the CXM 15 in white is also available: the CXM 15W.

OPTIMIZED FACTORY PRESETS INCLUDING FIR-TUNE LINEARIZATION ARE AVAILABLE FOR DSP 600, P 64 AND PowerH AMPLIFIERS WITH RCM-26 UNDER IRIS-NET.



AM 12

POWERED 2-WAY CABINET

■ **The perfect plug & play monitor solution for a great many applications, the AM 12 is armed with a DYNACORD LFT 3008 12" woofer and a constant directivity horn for the midrange and high frequencies.**

The integrated full-range Class H power amplifier delivers 300 W to the Lo channel, whilst the HF amplifier

supplies the Hi channel with 60 W. Thanks to the wide variety of available connection and programming options (Mic, Line and Aux) and the possibility of expanding the system through the addition of a passive monitor box, the AM 12 is capable of functioning either as a complete monitor system or as a small PA as well as being suit-

able for multimedia applications. Additional tools are offered by the acoustic processing section: the Lo EQ is an adjustable LPN filter to control the punch; the Mid EQ is a 4 kHz DIP filter that can be used to rein in the aggression of horn sections; whilst the High EQ allows you to increase or decrease the brilliance according to taste.





PowerMax 5

- F 150
- F 8





PowerMax 5

TWO-WAY ACTIVE SYTEM

■ **The PowerMax 5 system includes two 15" 2-way cabinets F 150, two 18" subwoofers F 8, one system power amplifier PM 2600, four system cables and two loudspeaker stand poles, making it a ready for operation, high-performance sound reinforcement system in active 2-way configuration that provides truly powerful sound.**

The system power amplifier includes the PowerMax controller and provides 2 x 700 W in the bass and 2 x 600 W in the Mid / Hi range. The system cabling ensures quick and easy installation and highest operational reliability. Using only a single PM 2600, it is possible to drive up to three Mid / Hi cabinets and three subwoofers per stereo channel.



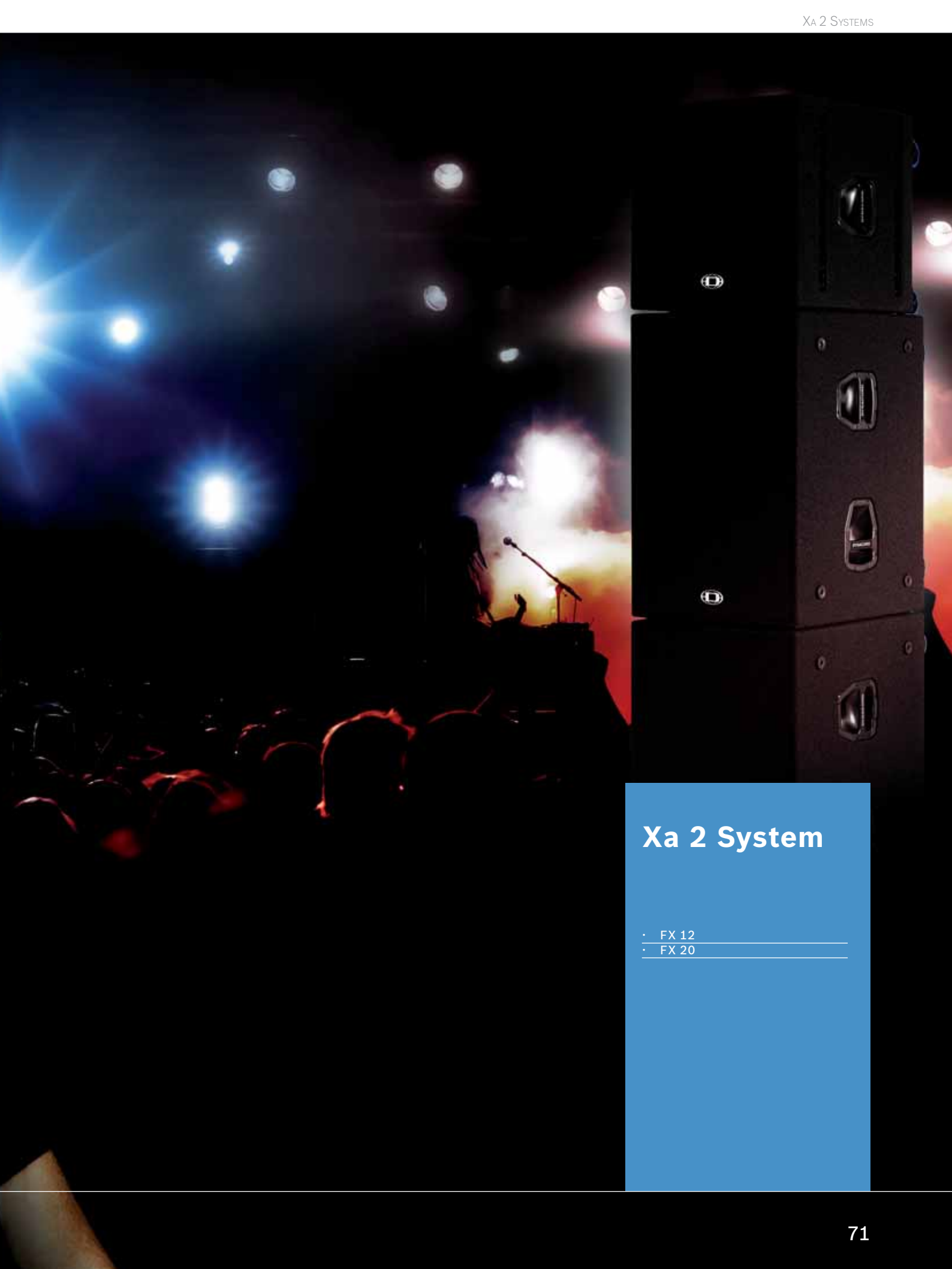

Xa 2 System

- FX 12
- FX 20

Xa 2 System

LOUDSPEAKER SYSTEMS

- Top 40 indoor / outdoor events
- high-powered mobile DJ events
- high quality corporate functions
- powerful speech reinforcement
- multimedia events
- theater applications
- rental
- fixed installation



In a world of excess and mass production, quality, functionality and design remain decisive factors. We at DYNACORD develop and manufacture first-class products – „Made in Germany“ – that not only supply detailed, optimized solutions to real problems encountered in day-to-day practice but are a joy to use, year after year.

In fact, achieving the highest possible quality levels and providing full and lasting satisfaction to our customers are our abiding and paramount objectives: obligations that admit of no exception. Complete audio systems with plug & play functionality have for many years been an indispensable part of the DYNACORD sound reinforcement range. The Xa 2 system

set new standards in terms of audio performance, reliability and value for money. Where the aim is to achieve the highest on-axis sound pressure levels possible, fully horn-loaded systems remain the first choice. Typical Top 40 events, city open-air events and mobile DJ events in which areas of up to 1,000 square meters have to be covered with throws of up to 40 meters – these are ideal applications for the Xa 2 systems from DYNACORD. High-quality neodymium components, combined with Constant Q horns and patented Planar Waveguide bass horns deliver maximum volume levels combined with the highest possible audio quality. Active two-way power amplifiers using Class H technology with switched-mode power supplies and audio processors as well as all

the requisite protective circuits are capable of driving the widest variety of system configurations with absolute reliability. Thanks to the VCTP protective circuits in the cabinets – the personal bodyguards of the loudspeakers – the maximum dynamic range is achieved along with the highest level of reliability.

Light and easy to transport, DYNACORD complete systems can be set up extremely quickly thanks in part to their clear and intuitive system cabling. These are advantages of real practical importance. So, too, are the time saved and peace of mind afforded by DYNACORD's extensive range of TÜV-certified accessories, such as the FG 600 Flying Grid (see Cobra), rigging ropes and wedges that satisfy even the most



OPTIMIZED FACTORY PRESETS INCLUDING FIR-TUNE LINEARIZATION ARE AVAILABLE FOR DSP 600, P 64 AND PowerH AMPLIFIERS WITH RCM-26 UNDER IRIS-NET.

problematic and complex rigging requirements simply and safely. To adapt to a multitude of very different sound reinforcement tasks and venue acoustics of all descriptions, the requisite Xa 2 components can be configured swiftly and simply without any need for complex

calculations, controller adjustments or programming of limiters. If at an open-air event extreme sound pressure levels are required in the sub-bass, one sub per side can be added. If the brass band playing in a marquee needs extremely broad coverage and fewer subs, a single

subwoofer but two angled tops per side should fit the bill. And if a Top 40 band suddenly finds itself with an audience 4,000 strong, the same system amp is also capable of driving three subs plus two tops as well as additional front- or side-fills without any difficulty.

Components

XA 2 SYSTEM

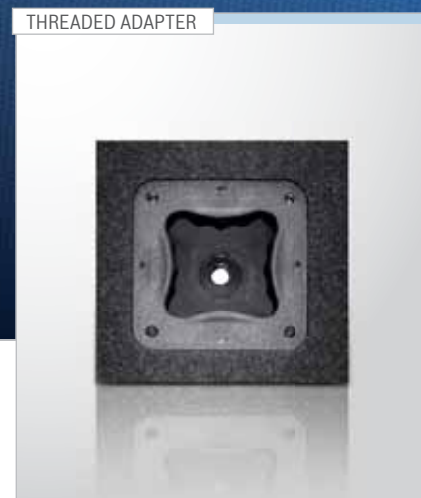
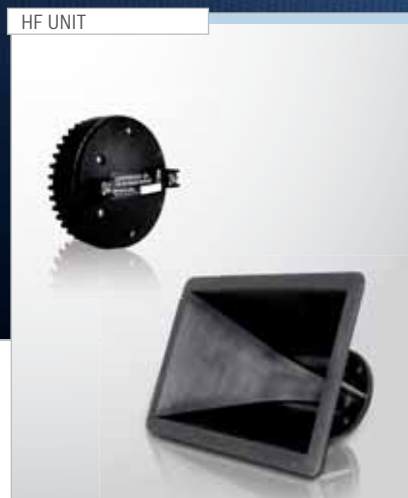

■ If you wish to use the Xa 2 top, the FX 12, as an individual cabinet (e.g. to provide high-quality sound reinforcement for the spoken word) driven by a power amplifier with normal pin assignments, the connector panel offers you the option of switching from „System“ (Pin 2+ / 2-) to „Normal“ (Pin 1+ / 1-) and in that way revert to a standard pin configuration.

■ The CDH 8040-14 80°x 40° Constant-Q HF horn with its ND 6-8 neodymium driver is responsible for transducing frequencies above 1 kHz and is mounted coaxially in the Conical Waveguide midrange horn.

■ Any additional full-range cabinets or smaller tops that may be required as front- or side-fills can be mounted securely on top of the FX 20 to save space and also aimed using the PCL 800 or VPM 1500 Threaded poles, which are available as accessories.

SUB UNIT



■ The Planar Waveguide Basshorn FX 20 is armed with an Electro-Voice heavy-duty EVX 180 B 18" woofer.

SPECIAL ACCESSORIES

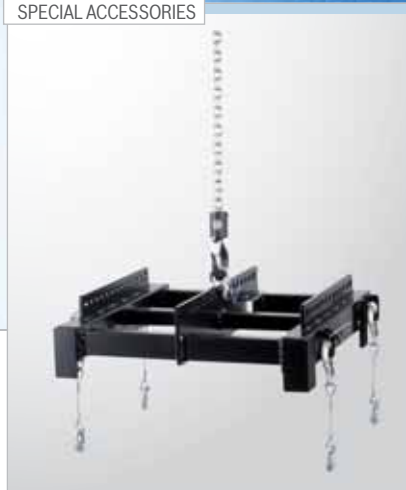

■ With the FG 600 Flying Grid, which is available as an accessory, the FX 12 can be flown safely and swiftly from a truss or attached to a genie (see Cobra). With the SE 600 Rigging Strap Extension and a webbing strap, an entire wing comprising multiple tops can be aimed swiftly and accurately.

FLYING RAILS...



■ The four flying tracks that are standard features of the FX 12 tops, in combination with the CSST Flying Wires available as accessories, make it easy to suspend the cabinets safely from trusses. Various detents are provided, so that just the right angle for each cabinet can be obtained. Further cabinets can be connected using CSSM Flying Wires equipped with double studs. The backs of both the FX 12 and the FX 20 boast four robust casters, whilst the tops are furnished with two, and the subwoofers with six, handles for easier transportation and to facilitate the safe stacking of the cabinets.



FX 12

2-WAY HI-POWER TOP



■ **The FX 12 is a fully horn-loaded and coaxial two-way, high-power top covering a bandwidth of 100 Hz to 19 kHz with a maximum sound pressure level of 134 dB / 1m.**

The frequency range from 1 kHz upwards is transduced by a neodymium ND 6-8 driver with a 3" voice coil and a CDH 8040-14 Constant-Q horn, whilst the midrange from 100 Hz to 1 kHz is the responsibility of a neodymium ND 12A driver with a large-format conical horn. Extremely low distortion and minimal comb-filter effects whether stacked or flown are among the decisive advantages of conical horns. The fully electronic Voice Coil Tracking Protection circuitry supervises the operating states of the individual loudspeakers on a permanent basis, intervening only in the case of overload by gently

reducing the power to the speakers (,soft-switching') until a safe level is reached. The result is the widest possible dynamic range combined with the highest level of operating security.

The cabinet is made from multiply poplar plywood covered by heavy-duty needle-felt carpeting. The front is securely protected by a powder-coated metal grille backed by acoustic foam. Handles at the side and four large casters on the rear facilitate handling.

Integrated flying tracks and rigging strap attachment points are standard features. The use of four-pole Speakon cables with system pin assignments eliminates the risk of accidental wiring errors when connecting the Xa 4000 system power amplifier or looping the signal through to an FX 20 subwoofer.



FX 20

PLANAR WAVEGUIDE SUB

■ **To generate the maximum possible sound pressure, the FX 20 subwoofer features a Planar Waveguide bass horn and a high-power EVX 180B 18" woofer.**

It covers a bandwidth from 30 Hz to 150 Hz with a maximum sound pressure level of 132 dB / 1 m. Two of these Planar Waveguide subwoofers deliver up to 138 dB / 1 m per side, creating an extremely dry and deep bass foundation for Xa 2 systems. Like the top, the 18" woofer is securely protected

against thermal overload by the Voice Coil Tracking Protection system, and even extremely high power peaks are transduced accurately and powerfully without compromising the dynamic range. The cabinet is made from multiply poplar plywood 15 mm thick covered by extremely hard-wearing needle-felt carpeting. Two FX 20 subwoofers stacked one on top of the other reach a height of 180 cm, creating the ideal plinth for an, overhead' stack of FX 12 tops. Again, the use of four-pole Speakon

cables obviates the risk of wiring errors when connecting up the system. The Sub signal supplied by the system power amplifier is on Pin 1+ / 1-, and the midrange / high frequency signal on pin 2+ / 2- is looped through to the tops.

Four large rubber feet on the side and the same number on the bottom provide for safe stacking in a variety of configurations. No fewer than six handles and four heavy-duty castors on the rear facilitate safe transportation.

SYSTEM AMP

XA 4000

The Xa 4000 system amp is a two-way (Sub-Top) power amplifier that can either be positioned laterally – for shorter cable runs to the cabinets – or centrally in the rack. Only two rack units in height and weighing a mere 8.25 kg, this Class H power amplifier is equipped with a switch-mode power supply of the latest generation. It outputs 1,100 W in the Sub and 900 W in the Top channel – in each case into 4 Ω. Up to three tops and three sub-

woofers, however, can be driven reliably and economically by a single amp. All the requisite signal processing including the equalization, LPN filter, low-cut filter and active crossover, with its crossover frequency of 140 Hz with 18 dB / octave in a modified Butterworth structure, is on board. From the front panel, the level of the Sub and Top channels can be set individually to allow optimization of the system to the geometry and acoustics of the room.







Cobra System

- Cobra-Top
- Cobra-Sub
- Cobra-4 Top
- Cobra-4 Far
- Cobra-PWH
- PWH 28
- Cobra-2 System
- Cobra-4 System



System Components

COBRA COMPACT LINE-ARRAY SYSTEM

In the events sound reinforcement business, among rental companies and in professional concert sound applications, two quite different loudspeaker concepts have secured their own niches: horn-loaded systems, which are notable for their high degree of efficiency, and line-array systems, which are

notable for their precisely defined coverage patterns.

In the rock 'n' roll business in particular, but more generally in any sound reinforcement context in which the emphasis is primarily upon obtaining very high sound pressure levels, horn-loaded systems con-

tinue to be the 'weapons of choice'. When multiple mid-high cabinets are used, however, it is physically impossible to eliminate altogether the comb filter effects that result from the less than optimal addition of the sound waves radiating from each cabinet. In more demanding concert sound applications, therefore, in

COBRA-4 TOP



COBRA-PWH



PWH 28



which far more is expected in terms of sound quality, line arrays have established for themselves a secure position in the market. Thanks to the extremely wide horizontal radiation pattern of line arrays, combined with their shallow and precisely defined vertical focus, the unwanted projection of sound waves onto ceilings and floors can be avoided, and, with it, the interference their reflection from such surfaces would otherwise cause. Conventional line arrays on the market, however, are mostly conceived exclusively as large-scale, ‚flying‘ sound reinforcement systems, and despite their advantages in terms of quality cannot always be

used for medium-sized events without quite considerable expense. In the Cobra-2 and Cobra-4 compact line-array systems, DYNACORD is offering a solution optimized in practice even for those applications that cannot economically be served by conventional, large-scale line arrays. The compact and easy to handle DYNACORD Cobra systems in ‚flown‘ but also in ‚stacked‘ configurations also make line-array performance available for the vast majority of those frequently encountered ‚bread and butter‘ events that take place typically in town halls, marquees or in cities in the open air. Reliability and operational security

at the highest level are guaranteed with the Cobra systems, to which the Voice Coil Tracking Protection (VCTP) to be found in each Cobra cabinet, serving as the personal bodyguard of each loudspeaker chassis, makes a valuable contribution. The fully-electronic VCPT safety circuit monitors on a permanent basis the thermal operating state of the individual loudspeakers and ensures, in the event only of overload, that the power driving it is „gently“ reduced until a safe value is reached. The result is the widest possible dynamic range combined with the maximum possible degree of operating security.

AS A RESULT OF THE HIGH SOUND PRESSURE LEVELS THEY GENERATE, THEIR OUTSTANDING COVERAGE AND THEIR SCALABILITY, COBRA-2 AND COBRA-4 SYSTEMS CAN BE USED IN A WIDE VARIETY OF CONTEXTS...

OPEN AIR FESTIVAL



CITY FESTIVAL



CITY OPEN AIR EVENT



MEGA DISCO



LARGE HIP-HOP OPEN AIR



GALA EVENT



IRIS-NET

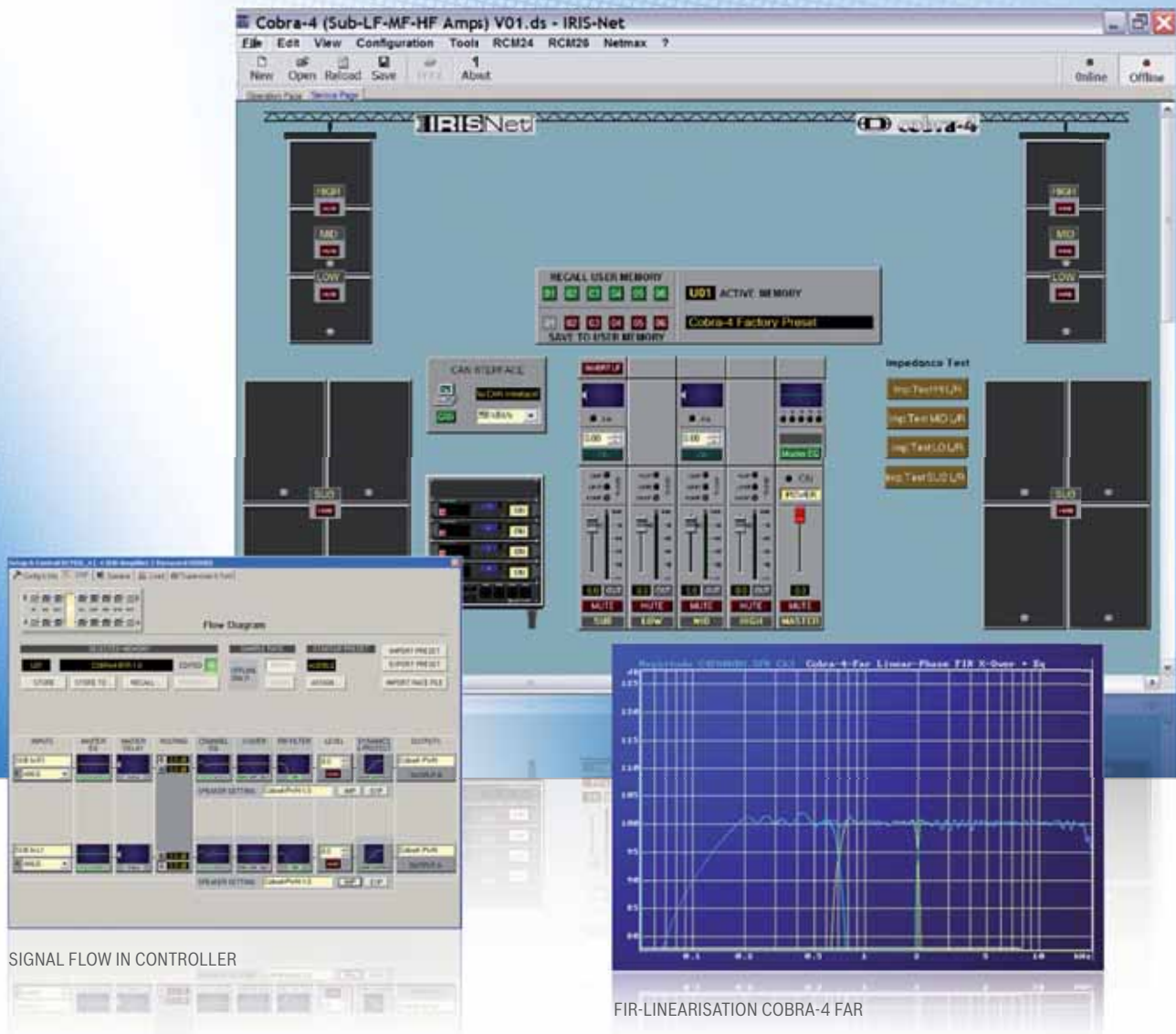

FIR Tune System Drives

FOR COMPACT-LINE-ARRAY SYSTEMS

■ For the various systems, specific preconfigured system drives are available, which in their maximum configuration with PowerH power amplifiers or DSP 600 or a P 64 matrix under IRIS-Net include even remote supervision and control, and DSP presets with FIR filter linearization.

To simplify setting up the system, IRIS-Net contains standard project files. These project files make tuning Cobra systems swift and intuitive, since they already contain all the crossover and FIR equalization functions needed – though these can, if desired, also be edited by the user. The result

of the FIR equalization is absolutely linear frequency and phase response throughout the system. This provides the ideal starting point from which the FOH engineer can proceed at once to the task of tuning the system to the acoustics of the venue – whether in- or out-of-doors.



COBRA-TOP

The flyable passive three-way FULL-RANGE / MID-HIGH component in the Cobra-2 system. Armed with a 15" Electro-Voice EVX155 speaker for the low frequency range, a coaxial midrange line-array composed of four C8 conical midrange drivers, and a DH 2T titanium driver with a CD horn for the high frequency range.

COBRA-4 TOP

The flyable active three-way MID-HIGH component in the Cobra-4 system. Armed with a 15" Electro-Voice EVX 155 speaker for the low frequency range, a coaxial midrange line-array composed of four C 8 conical midrange drivers and a DH 2T radiating into a CD horn for the high frequency range.





COBRA-SUB

Flyable subwoofer with a bass-reflex design armed with an Electro-Voice 18" EVX 180 B driver. With grooves to enhance stacking stability and four ANCRA flying tracks for flown sub-arrays included in the delivery.



COBRA-4 FAR

The flyable active three-way far-field MID-HIGH component in the Cobra-4 system. Identically equipped in the low and midrange to the Cobra-4 top but featuring a 5° vertical high frequency line array, composed of three Electro-Voice DH 2T titanium drivers with an HF waveguide horn.



PWH 28

1,400 W planar-waveguide-horn-loaded, high-power sub-woofer equipped with 2 x 18" LFS 18700 transducers for very high sound pressure levels and long throws in Cobra-4 systems.



**COBRA-PWH**

A planar waveguide horn subwoofer armed with an Electro-Voice 18" EVX 180 B driver for bass reproduction in the Cobra-2 and Cobra-4 systems that is particularly powerful and carries especially far.

02

05

06



■ The FG 600 Flying Grid is suitable for all the cabinets in the Cobra (and FX) series that are equipped with airline profiles for rigging.

The complete flight system consists of the FG 600 Flying Grid and the SE-600 Strap Extension. Each of these accessory items is supplied with undetachable logging pins making assembly possible without the use of tools. The maximum load with a safety factor of 12 is 460 kg. With large loudspeaker constellations it is sometimes necessary to brace the array from behind. With the SE-600 Strap Extension, which can be inserted at the rear and secured with spherical locking pins, it is possible to align the entire wing.

Rigging Accessories

- 01** TC-04 - Truss Clamp, 2", M12 Ring Nut
- 02** FG 600 - Flying Grid, TÜV approved
- 03** SE 600 - Strap Extension for FG 600
- 04** CSSG - Cobra System Strap Grid (without picture)
- 05** CSST - Rigging Strap (Truss > Cabinet)
- 06** CSSM - Rigging Strap (Cabinet > Cabinet)
- 07** CSW 25 - Wedge Set (2 x Wedge 2,5°)
- 08** WS-04 - Webbing Strap 4 m (1-3 Cabinets)
- 09** WS-08 - Webbing Strap 8 m (4-8 Cabinets)



System Racks





ICP-88



ICP-48



ICP-44



CP-48



AC 232



■ **Factory-assembled System Racks are available with DSP controller, power amplifiers and an AF panel as well as an AC panel mounted at the rear with a 32 A power supply connector.**

Naturally the racks can be configured freely to suit the application or the requirements of the customer – typically through the inclusion of LX or PowerH power amplifiers (optionally with RCM-26 DSP modules), DSP 260, DSP 600 or P 64 controllers, and any of a variety of different connector panels.



Cobra-2

COMPACT LINE-ARRAY ACTIVE 2-WAY SYSTEM

■ **The Cobra-2 system is designed to provide high-quality sound reinforcement for events in small to medium-sized marquees or halls covering distances of up to 40 meters and areas up to 1,000 square meters.**

The system produces a maximum sound pressure level of 137 dB L and 137 dB R in the mid / high frequency range and up to 141 dB in the bass. In its basic configuration, the Cobra-2 system comprises four Cobra-Top mid / high cabinets, four Cobra-Sub subwoofers, a ready-wired and pre-programmed system amp rack and the requisite 4-pin loudspeaker system cables along with a set of wedges (two 2.5° wedges that can be used either side) that make it possible to aim the Cobra-Top cabinet to suit the

area to be covered. The system amp racks are easily capable of driving up to six Cobra-Top and/or six Cobra-Sub cabinets. If it is desired to expand the system, the amp rack is capable of accommodating additional power amplifiers (bass extension, front- / side-fills or monitors) as well as supplying them with the requisite power via the AC connector panel.

The maximum Cobra-2 configuration that makes sense comprises two Cobra-2 systems per side (four Cobra-Tops and four to six Cobra-Subs per side). Since, however, doubling the number of stacked or flown Cobra-Top cabinets results in a halving of the vertical coverage angle, particular attention must be paid in such cases to the aiming of the cabinets in the wing

or stack. A single Cobra-Top has a (horizontal x vertical) coverage pattern of 120° x 30°; this is reduced to 120° x 15° if a second, and to 120° x 7.5° if a third, Cobra-Top is added to the stack. When ground-stacked, the Cobra-Top cabinets can be aimed with precision at the area to be covered through the use of the 2.5° wedges that are supplied as standard. If added pressure or projection is needed in the bass, whether due to the style of music or to the acoustics of the venue, Cobra-2 systems can also be armed with Cobra-PWH bass horns.

With two PWH cabinets (or three Cobra-Subs) superposed, you obtain a plinth the ideal height (180 cm) for ground-stacking the Cobra-Top cabinets on.



OPTIMIZED FACTORY PRESETS INCLUDING FIR-TUNE LINEARIZATION ARE AVAILABLE FOR DSP 600, P 64 AND PowerH AMPLIFIERS WITH RCM-26 UNDER IRIS-NET

Cobra-4

COMPACT LINE-ARRAY ACTIVE 4-WAY SYSTEM

■ **The active 4-way Cobra-4 System in its standard configuration is designed for throws of up to 80 meters in medium-sized marquees, halls and open-air venues.**

It is capable of generating at a FOH position 30 meters distant a sound pressure level of 110 dB in the mid-high frequency range and 120 dB in the bass – exactly what the typical Top 40 band requires. Through the use of two Cobra-4 Tops and one Cobra-4 Far, optimum line-array performance can be obtained even from a typical

stacked configuration without time-consuming adjustments. For large distances, the top position in the stack is reserved for a Cobra-4 Far unit, which has a coverage pattern of 90° (horizontally) and 5° (vertically) in the high frequency range.

For the low frequency and midrange, the same components are used as in the Cobra-4 Top, providing the ideal extension for the low- and midrange line array. In all, eight Cobra-PWH bass horns are needed to generate the pressure and projection in the bass region

required by typical Top 40 bands. Depending upon the geometry of the room, these can be stacked or arranged as a horizontal bass array.

The Cobra-4 System can be driven either by ready-wired and pre-programmed amp racks, comprising a controller, power amplifiers and AF- and AC connector panels, or by individual (user-configured) racks. When PowerH power amplifiers are used in conjunction with RCM-26 modules, advantage can be taken of FIR-linearized presets.

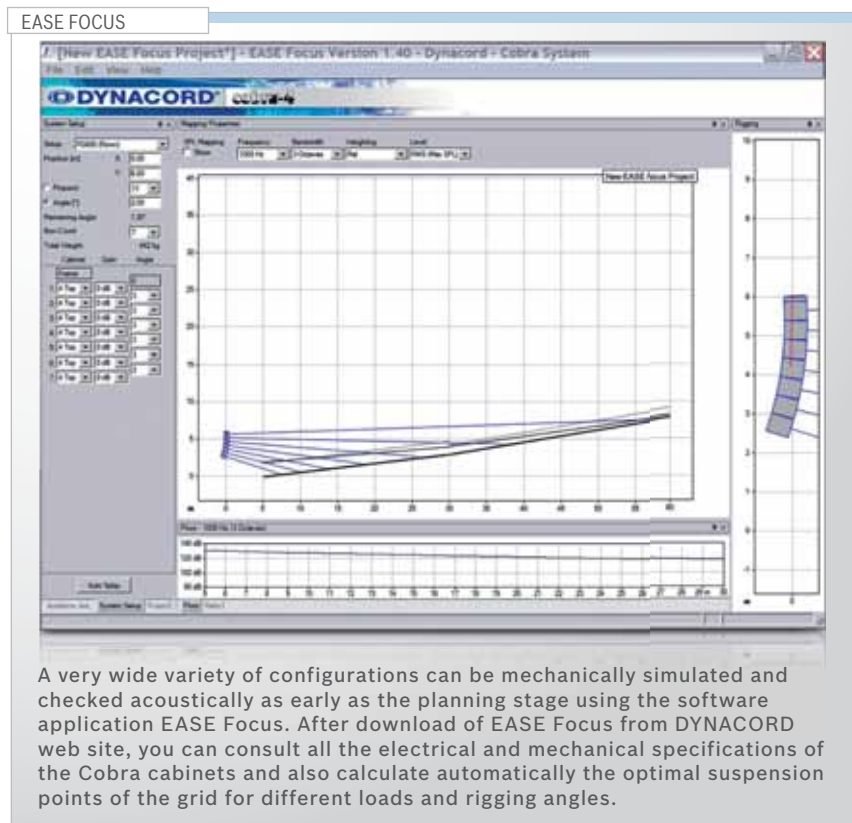

OPTIMIZED FACTORY PRESETS INCLUDING FIR-TUNE LINEARIZATION ARE AVAILABLE FOR DSP 600, P 64 AND PowerH AMPLIFIERS WITH RCM-26 UNDER IRIS-NET





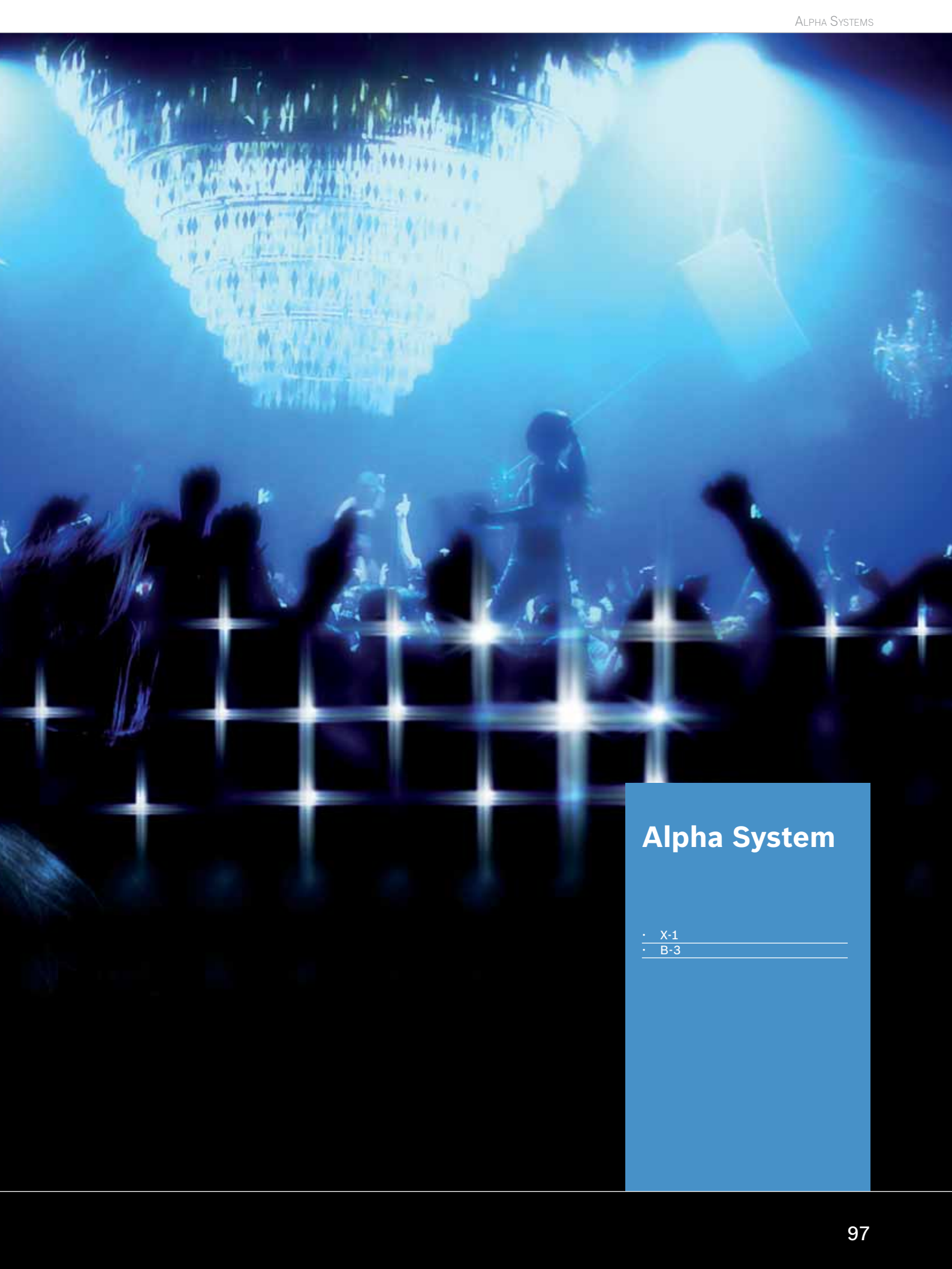

Alpha System

- X-1
- B-3

■ **What was designed without compromise remains free from compromise: in their almost fifteen-year history, Alpha systems have never tasted defeat; and their triumphant progress continues apace, with successful installations all over the globe.**

Their legend lies not only in their extreme reliability but also in their extraordinarily clean (and gigantically powerful!) sound.

Alpha systems are to be found in the most up-market, the most fashionable and the most popular

clubs and discotheques in Las Vegas, Miami and New York, throughout Asia and the Middle East, and, of course, also in Europe. The Alpha guarantees a club enthusiastic guests, thereby ensuring a sure and swift return on its investment.

Alpha X-1

HORN-LOADED THREE-WAY HI-POWER LOUDSPEAKER SYSTEM

■ **The Alpha X-1 system is a horn-loaded, three-way loudspeaker system.**

The two vented 15" loudspeakers combine with a conical short horn to deliver extremely precise and punchy midrange and low frequency reproduction that extends right down to 80 Hz and beyond. The 2" high-performance driver with its

True Constant Directivity horn (90° x 40° or 60° x 40°, according to choice) offers in the range from 800 Hz to 8 kHz truly dynamic mid-high reproduction, rich in presence. The brilliant high-frequency reproduction of the 90° and 60° horns is ensured by a pair of diffraction or ring radiators respectively. The Alpha X-1's trapezoidal cabinet design

facilitates the formation of multiple-component clusters. The Alpha X-1 can be driven in active two-way or active three-way mode, according to choice. But whichever mode is selected, every loudspeaker chassis is reliably protected by thermal circuit breakers or halogen lamps against critical power levels as well as short-term thermal overload.

Alpha B-3

2 x 18" PWH SUBWOOFER-SYSTEM

■ **The Alpha B-3 system is a 2 x 18" PWH subwoofer system employing Planar Waveguide technology.**

A PWH horn is a planar waveguide horn with a Helmholtz resonator placed inside the wave guide. The resulting 6 to 7 dB gain in SPL in the low frequency range is a product of the interaction between the resonance of the waveguide

and that of the Helmholtz resonator. At the same time, the design of the PWH subwoofer is such as to limit the cone's excursion, protecting the diaphragm and guaranteeing outstandingly accurate impulse reproduction, a very wide dynamic range, extremely low distortion, and prolonged reliable operation. alpha B-3 systems offer directivity in the low-frequency range

down to 30 Hz. They combine the advantages of both direct-radiating and horn-loaded systems, and – thanks to their unique design – are markedly superior to conventional solutions.

Dynamic protections safeguard the two 18" speakers reliably against critical power levels as well as short-term thermal overload.

SYSTEM DRIVES

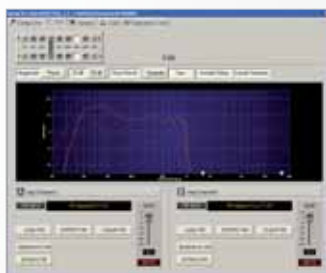
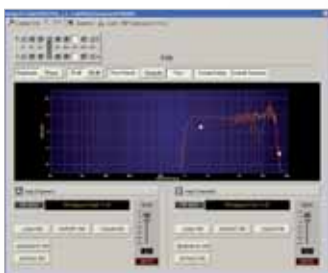

IRISNet

To drive the system, we recommend high-performance power amplifiers from DYNACORD's PowerH series equipped with the RCM-26 Digital FIR Controller. Naturally, optimized settings (including FIR filter linearization) are available for alpha systems too through the use of IRIS-Net software.



D-Lite SERIES TECHNICAL SPECIFICATIONS

D-Lite SERIES

Type / Name	D 8 / D 8W	D 8A	D 11A	D 12 / D 12W		
Cabinet	Fullrange	Fullrange	Fullrange	Fullrange		
Configuration	Passive 2-Way	Powered 2-Way	Powered 2-Way	Passive 2-Way		
Components	8" / 1"	8" / 1"	12" / 1"	12" / 1"		
Impedance	8 Ohms	---	---	8 Ohms		
Rated Power RMS	250 W	200 W HF 200 W LF	200 W HF 200 W LF	300 W		
Peak Power	1000 W	---	---	1200 W		
Max. Amplifier Output Capability	---	800 W	800 W	---		
SPL 1 W / 1 m	94 dB	---	---	98 dB		
Max. SPL 1 m / calc.	124 dB	123 dB	126 dB	129 dB		
Freq. Range	65 Hz - 18 kHz	56 Hz - 20 kHz	48 Hz - 20 kHz	70 Hz - 18 kHz		
Coverage (H x V)	90° x 90°	90° x 90°	80° x 40°	80° x 40°		
Dimensions (W x H x D) mm	282 x 442 x 259	282 x 442 x 259	430 x 586 x 321	430 x 586 x 321		
Net. Weight	8.8 kg	9.0 kg	15.3 kg	16 kg		
Accessories	page 44 - 45	page 44 - 45	page 44 - 45	page 44 - 45		

D-Lite SERIES

Type / Name	D 12T / D 12TW	D 12R / D 12RW	D 12-3	D 15-3		
Cabinet	Fullrange	Fullrange	Fullrange	Fullrange		
Configuration	Passive 2-Way 100V Transformer	Passive 2-Way Weatherproof	Passive 3-Way	Passive 3-Way		
Components	12" / 1"	12" / 1"	12" / 6" / 1"	15" / 6" / 1"		
Impedance	33 / 66 / 133 Ohms	8 Ohms	8 Ohms	8 Ohms		
Rated Power RMS	300 / 150 / 75 W	300 W	350 W	500 W		
Peak Power	1200 W	1200 W	1400 W	2000 W		
SPL 1 W / 1 m	98 dB	98 dB	100 dB	100 dB		
Max. SPL 1 m / calc.	129 dB	129 dB	131 dB	133 dB		
Freq. Range	70 Hz - 18 kHz	70 Hz - 18 kHz	70 Hz - 20 kHz	50 Hz - 20 kHz		
Coverage (H x V)	80° x 40°	80° x 40°	90° x 50°	90° x 50°		
Dimensions (W x H x D) mm	430 x 586 x 321	430 x 586 x 321	430 x 586 x 321	447 x 686 x 413		
Net. Weight	18.6 kg	16.2 kg	19 kg	24 kg		
Accessories	page 44 - 45	page 44 - 45	page 44 - 45	page 44 - 45		

D-Lite SERIES

Type / Name	Sub 112	Sub 115	Sub 118		
Cabinet	Subwoofer	Subwoofer	Subwoofer		
Configuration	Vented - Direct Radiator	Vented - Direct Radiator	Vented - Direct Radiator		
Components	1 x 12"	1 x 15"	1 x 18"		
Impedance	8 Ohms	8 Ohms	8 Ohms		
Rated Power RMS	400 W	400 W	700 W		
Peak Power	1600 W	1600 W	2800 W		
SPL 1 W / 1 m	92 dB	99 dB	98 dB		
Max. SPL 1 m / calc.	124 dB	131 dB	132 dB		
Freq. Range	43 Hz - 350 Hz (internal Hi-Cut)	55 Hz - 320 Hz (internal Hi-Cut)	30 Hz - 300 Hz (internal Hi-Cut)		
Dimensions (W x H x D) mm	445 x 380 x 445	464 x 601 x 660	547 x 724 x 658		
Net. Weight	20 kg	34 kg	50 kg		
Accessories	page 44 - 45	page 44 - 45	page 44 - 45		

D-Lite SERIES

Type / Name	PowerSub 112	PowerSub 212	PowerSub 312	PowerSub 315	
Cabinet	Subwoofer	Subwoofer	Subwoofer	Subwoofer	
Configuration	Powered 1-Channel	Powered 1-Channel	Powered 3-Channel	Powered 3-Channel	
Components	1 x 12"	2 x 12"	1 x 12"	1 x 15"	
Rated Power RMS	200 W	400 W	2 x 250 W MH 1 x 800 W LF	2 x 500 W MH 1 x 1000 W LF	
Max. Amplifier Output Capability	400 W	800 W	1800 W	2000 W	
Max. SPL 1 m / calc.	121 dB	127 dB	123 dB	129 dB	
Freq. Range	40 Hz - 130 Hz	40 Hz - 130 Hz	44 Hz - 130 Hz	34 Hz - 160 Hz	
Dimensions (W x H x D) mm	445 x 380 x 445	445 x 755 x 445	445 x 380 x 445	464 x 601 x 660	
Net. Weight	20 kg	39.5 kg	22.5 kg	45 kg	
Accessories	page 44 - 45	page 44 - 45	page 44 - 45	page 44 - 45	

VariLine TECHNICAL SPECIFICATIONS

VariLine						
Type / Name	VL 62 / VL 62W	VL 262 / VL 262W	VL 122	VL 152	VL 212	
Cabinet	Fullrange	Fullrange	Fullrange	Fullrange	Fullrange	
Configuration	Passive 2-Way	Passive 2-Way	Passive 2-Way or Active 2-Way	Passive 2-Way or Active 2-Way	Passive 2-Way or Active 2-Way	
Components	1 x 6" / 1"	2 x 6" / 1"	1 x 12" / 1.4"	1 x 15" / 1.4"	2 x 12" / 1.4"	
Impedance	16 Ohms	8 Ohms	8 Ohms	8 Ohms	4 Ohms	
Rated Power RMS	150 W	300 W	400 W	500 W	800 W	
Peak Power	600 W	1200 W	1600 W	2000 W	3200 W	
SPL 1 W / 1 m	94 dB	97 dB	99 dB	100 dB	102 dB	
Max. SPL 1 m / calc.	122 dB	128 dB	131 dB	133 dB	137 dB	
Freq. Range	90 Hz - 20 kHz	90 Hz - 20 kHz	60 Hz - 20 kHz	50 Hz - 20 kHz	80 Hz - 20 kHz	
Coverage (H x V)	90° x 40°	90° x 40°	90° x 45°	90° x 45°	90° x 45°	
Dimensions (W x H x D) mm	217 x 375 x 230	217 x 543 x 230	385 x 715 x 374	441 x 780 x 407	385 x 1035 x 374	
Net. Weight	8 kg	10 kg	24 kg	26 kg	34 kg	
Accessories	page 60 - 61	page 60 - 61	page 60 - 61	page 60 - 61	page 60 - 61	

VariLine						
Type / Name	SUB 18	SUB 28				
Cabinet	Subwoofer	Subwoofer				
Configuration	Vented - Direct Radiator	Vented - Direct Radiator				
Components	1 x 18"	2 x 18"				
Impedance	8 Ohms	4 Ohms				
Rated Power RMS	700 W	1400 W				
Peak Power	2800 W	5600 W				
SPL 1 W / 1 m	98 dB	101 dB				
Max. SPL 1 m / calc.	132 dB	138 dB				
Freq. Range	35 Hz - 700 Hz	35 Hz - 700 Hz				
Dimensions (W x H x D) mm	505 x 805 x 570	605 x 1205 x 675				
Net. Weight	49 kg	82 kg				
Accessories	page 60 - 61	page 60 - 61				

CXM 15 / CXM 15W TECHNICAL SPECIFICATIONS

CXM 15 / CXM 15W						
Type / Name	CXM 15	CXM 15W				
Cabinet	Coaxial Monitor	Coaxial Monitor				
Configuration	Passive 2-Way or Active 2-Way	Passive 2-Way or Active 2-Way				
Components	15" / 1.4"	15" / 1.4"				
Impedance	8 Ohms	8 Ohms				
Rated Power RMS	450 W	450 W				
Peak Power	1800 W	1800 W				
SPL 1 W / 1 m	102 dB	102 dB				
Max. SPL 1 m / calc.	135 dB	135 dB				
Freq. Range	100 Hz - 18 kHz	100 Hz - 18 kHz				
Coverage (H x V)	60° x 60°	60° x 60°				
Dimensions (W x H x D) mm	600 x 334 x 412	600 x 334 x 412				
Net. Weight	19 kg	19 kg				

AM 12 TECHNICAL SPECIFICATIONS

AM 12						
Type / Name	AM 12					
Cabinet	Monitor					
Configuration	Powered 2-Way					
Components	12" / 1"					
Rated Power RMS	40 W HF 250 W LF					
Max. Amplifier Output Capability	510 W					
Max. SPL 1 m / calc.	125 dB					
Freq. Range	80 Hz - 18 kHz					
Coverage (H x V)	90° x 40°					
Dimensions (W x H x D) mm	531 x 355 x 344					
Net. Weight	21 kg					

PowerMax 5 TECHNICAL SPECIFICATIONS

PowerMax 5						
Type / Name	F 150	F 8				
Cabinet	Fullrange	Subwoofer				
Configuration	Passive 2-Way	Vented - Direct Radiator				
Components	15" / 1"	1 x 18"				
Impedance	8 Ohms	8 Ohms				
Rated Power RMS	400 W	500 W				
Peak Power	800 W	1000 W				
SPL 1 W / 1 m	102 dB	100 dB				
Max. SPL 1 m / calc.	131 dB	130 dB				
Freq. Range	70 Hz - 18 kHz	40 Hz - 300 Hz (internal Hi - Cut)				
Coverage (H x V)	90° x 40°	---				
Dimensions (W x H x D) mm	522 x 755 x 395	522 x 737 x 674				
Net. Weight	26.5 kg	38 kg				

Xa 2 SYSTEM TECHNICAL SPECIFICATIONS

Xa 2 SYSTEM						
Type / Name	FX 12	FX 20				
Cabinet	Mid - High	Subwoofer				
Configuration	Passive 2-Way Horn loaded	Planar Wave-guide Horn				
Components	12" / 1.4"	1 x 18"				
Impedance	8 Ohms	8 Ohms				
Rated Power RMS	350 W	600 W				
Peak Power	700 W	1200 W				
SPL 1 W / 1 m	106 dB	101 dB				
Max. SPL 1 m / calc.	134 dB	132 dB				
Freq. Range	120 Hz - 19 kHz	30 Hz - 150 Hz				
Coverage (H x V)	80° x 40°	---				
Dimensions (W x H x D) mm	600 x 610 x 814	600 x 905 x 814				
Net. Weight	48 kg	47.5 kg				

Cobra SYSTEM TECHNICAL SPECIFICATIONS

Cobra SYSTEM						
Type / Name	Cobra-Top	Cobra-4 Top	Cobra-4 Far	Cobra-Sub	Cobra-PWH	PWH 28
Cabinet	Fullrange	Fullrange	Fullrange	Subwoofer	Subwoofer	Subwoofer
Configuration	Passive 3-Way	Active 3-Way	Active 3-Way	Vented - Direct Radiator	Planar Wave-guide Horn	Planar Wave-guide Horn
Components	15" / 4 x 4" / 1"	15" / 4 x 4" / 1"	15" / 4 x 4" / 3 x 1"	1 x 18"	1 x 18"	2 x 18"
Impedance	8 Ohms	8 - 8 - 8 Ohms	8 - 8 - 8 Ohms	8 Ohms	8 Ohms	4 Ohms
Rated Power RMS	600 W	400 - 200 - 100 W	400 - 200 - 200 W	600 W	600 W	1400 W
Peak Power	1200 W	800 - 400 - 200 W	800 - 400 - 400 W	1200 W	1200 W	5600 W
SPL 1 W / 1 m	100 dB	100 dB	100 dB	98 dB	101 dB	103 dB
Max. SPL 1 m / calc.	131 dB	131 dB	131 dB	129 dB	132 dB	140 dB
Freq. Range	50 Hz - 15 kHz	50 Hz - 17 kHz	50 Hz - 17 kHz	30 Hz - 170 Hz	30 Hz - 150 Hz	33 Hz - 2 kHz
Coverage (H x V)	90° x 40°	90° x 40°	90° x 5° (HF)	---	---	---
Dimensions (W x H x D) mm	600 x 495 x 717	600 x 495 x 717	600 x 495 x 717	600 x 615 x 717	605 x 910 x 823	1205 x 605 x 1306
Net. Weight	60 kg	54.5 kg	63.5 kg	58 kg	72 kg	129 kg
Accessories	page 88 - 89	page 88 - 89	page 88 - 89	page 88 - 89	page 88 - 89	page 88 - 89

Alpha SYSTEM TECHNICAL SPECIFICATIONS

Alpha SYSTEM						
Type / Name	X1-90	B-3				
Cabinet	Mid - High	Subwoofer				
Configuration	Active 3-Way or Active 2-Way	Planar Wave-guide Horn				
Components	2 x 15" / 2" / 2 x Slot	2 x 18"				
Impedance	4 - 8 - 4 Ohms	4 Ohms				
Rated Power RMS	800 - 600 - 100 W	1000 W				
Peak Power	1600 - 1200 - 200 W	2000 W				
SPL 1 W / 1 m	106 dB	103 dB				
Max. SPL 1 m / calc.	135 dB	133 dB				
Freq. Range	63 Hz - 23 kHz	35 Hz - 1.7 kHz				
Coverage (H x V)	90° x 40°	---				
Dimensions (W x H x D) mm	763 x 1440 x 720	1200 x 610 x 1220				
Net. Weight	137 kg	120 kg				

Application Guide

D-Lite SERIES APPLICATION GUIDE

D-Lite activeone SMALL CLUBS, MOBILE DJs

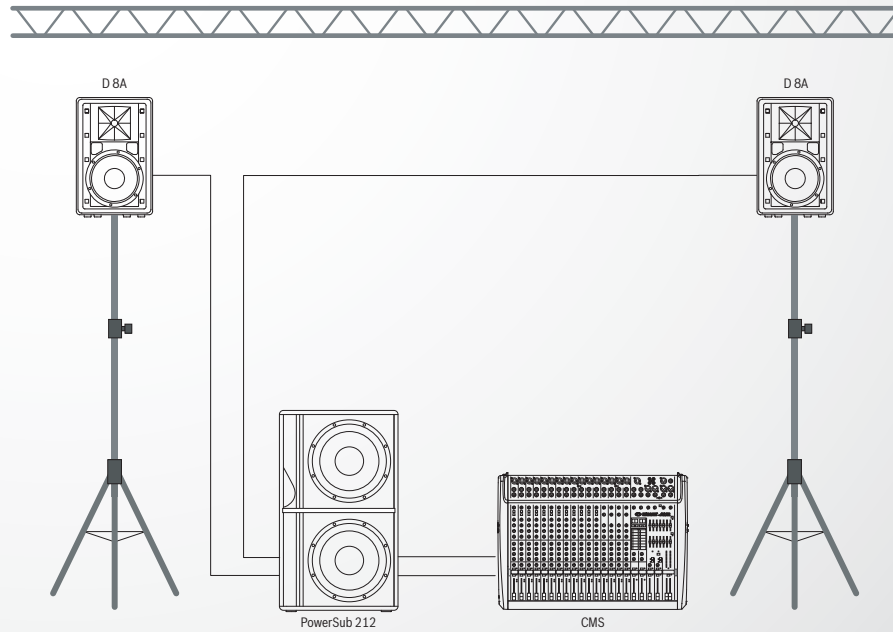

Configuration	Active 3-Way
Cabinet Types	2 x D 8A, 1 x PowerSub 212
Amplifiers	internal
Controllers	-
Cables	XLR - XLR
Accessories	2 x BS 35
Horizontal Coverage	2 x 90°
Total Amp Power	2400 W
Typical Distance	10 - 15 m
Options	-
Comments	-

D-Lite activeone PLUS CLUBS, MOBILE DJs

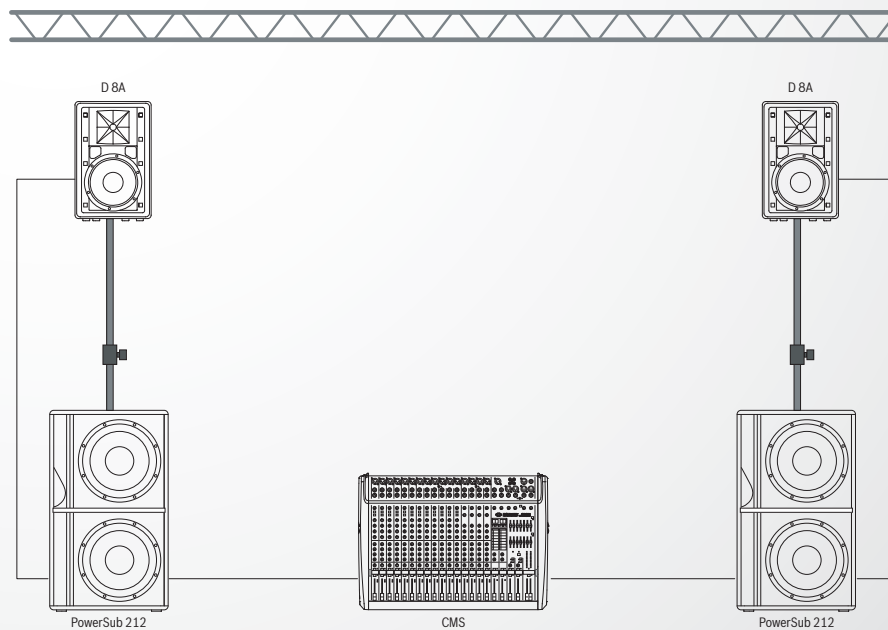

Configuration	Active 3-Way
Cabinet Types	2 x D 8A, 2 x PowerSub 212
Amplifiers	internal
Controllers	-
Cables	XLR - XLR
Accessories	2 x VPM 1500
Horizontal Coverage	2 x 90°
Total Amp Power	3200 W
Typical Distance	15 - 20m
Options	-
Comments	-

D-Lite SERIES APPLICATION GUIDE

D-Lite activetwo SMALL CLUBS

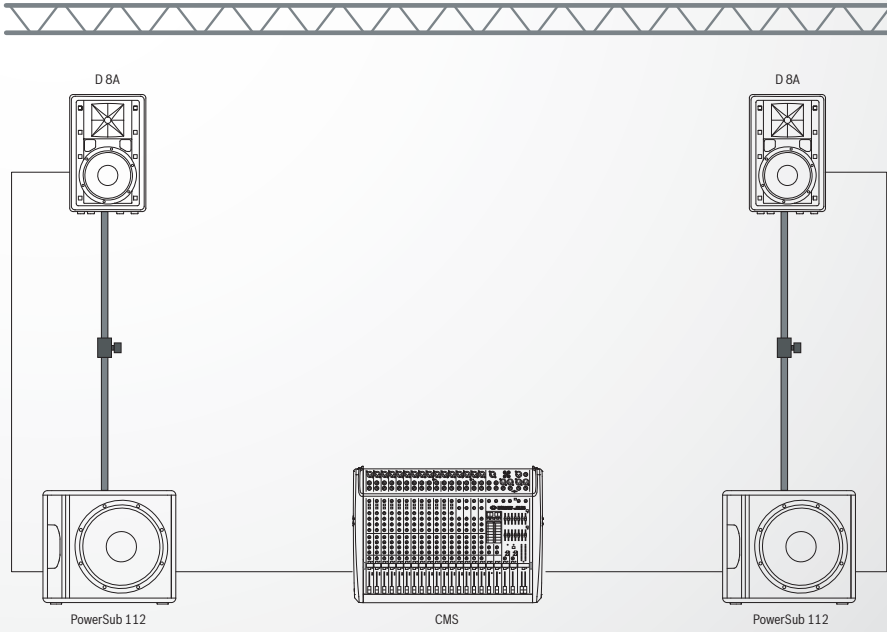

Configuration	Active 3-Way
Cabinet Types	2 x D 8A, 2 x PowerSub 112
Amplifiers	internal
Controllers	-
Cables	XLR - XLR
Accessories	2 x VPM 1500
Horizontal Coverage	2 x 90°
Total Amp Power	2400 W
Typical Distance	10 - 15m
Options	-
Comments	-

D-Lite activefour MUSICIANS, SMALL CLUBS

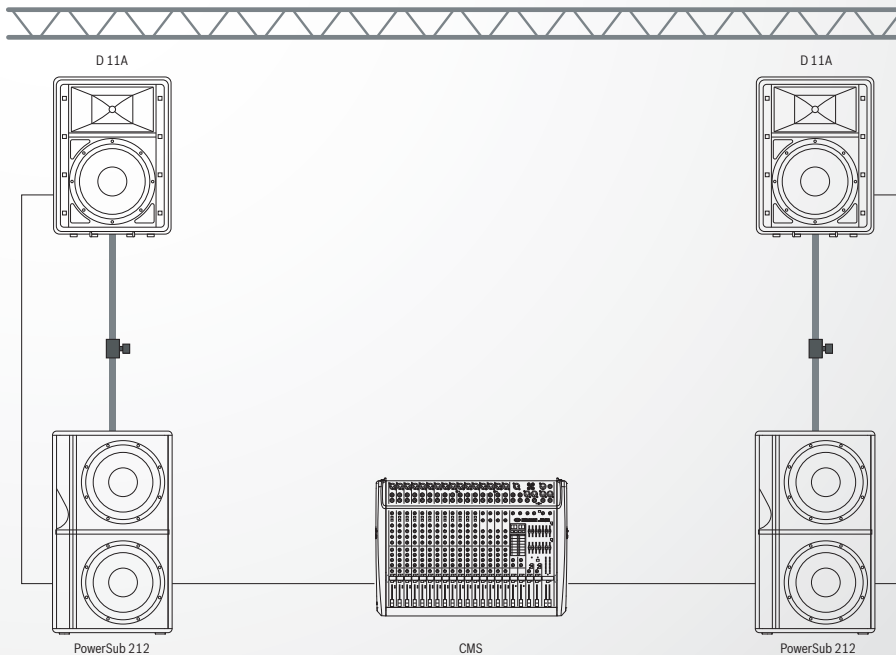

Configuration	Active 3-Way
Cabinet Types	2 x D 11A, 2 x PowerSub 212
Amplifiers	internal
Controllers	-
Cables	XLR - XLR
Accessories	2 x VPM 1500
Horizontal Coverage	2 x 80°
Total Amp Power	3200 W
Typical Distance	15 - 20 m
Options	-
Comments	-

D-Lite MUSICIANS, SMALL CLUBS

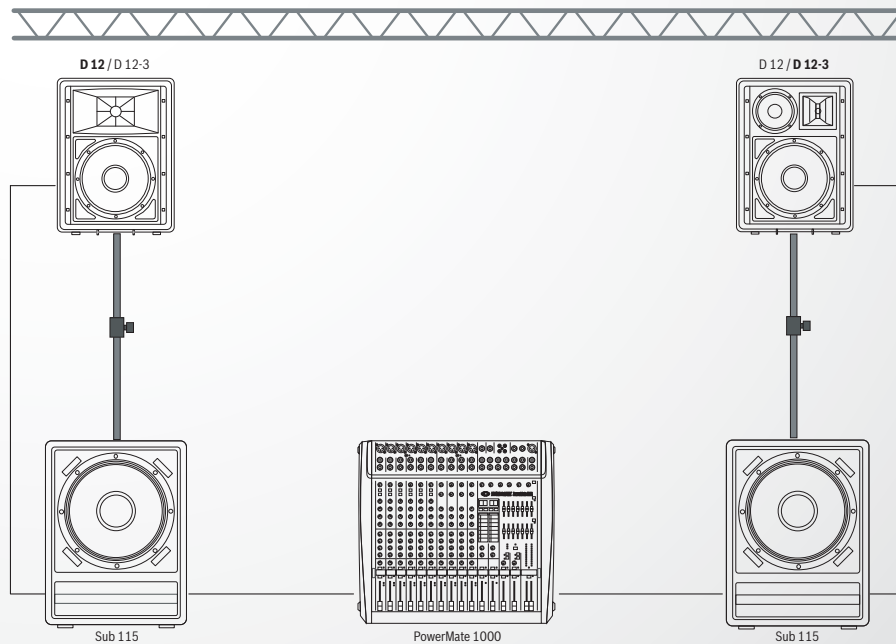

Configuration	Fullrange
Cabinet Types	2 x D 12 or 2 x D 12-3, 2 x Sub 115
Amplifiers	PowerMate 1000
Controllers	-
Cables	-
Accessories	2 x VPM 1500
Horizontal Coverage	2 x 80°
Total Amp Power	2 x 700 W
Typical Distance	10 - 15 m
Options	-
Comments	one added Top or one added Sub can be driven on each side (3 x 8 ohms)

D-Lite LIVE BANDS, MEDIUM CLUBS

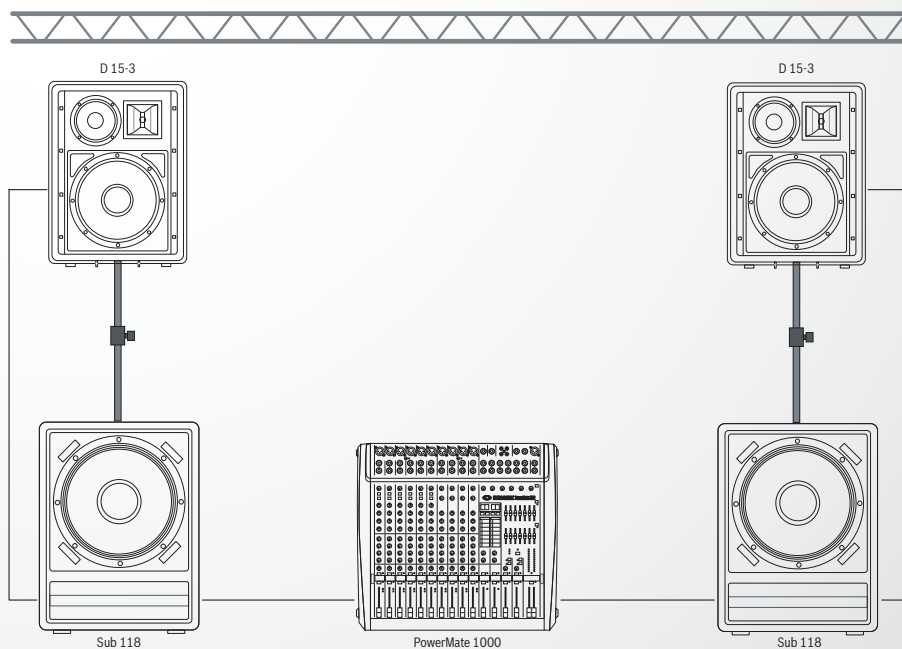

Configuration	Fullrange
Cabinet Types	2 x D 15-3, 2 x Sub 118
Amplifiers	PowerMate 1000
Controllers	-
Cables	-
Accessories	2 x VPM 1500
Horizontal Coverage	2 x 80°
Total Amp Power	2 x 700 W
Typical Distance	15 - 20 m
Options	-
Comments	one added Top or one added Sub can be driven on each side (3 x 8 ohms)

D-Lite SERIES APPLICATION GUIDE

D-Lite LIVE BANDS, MEDIUM CLUBS

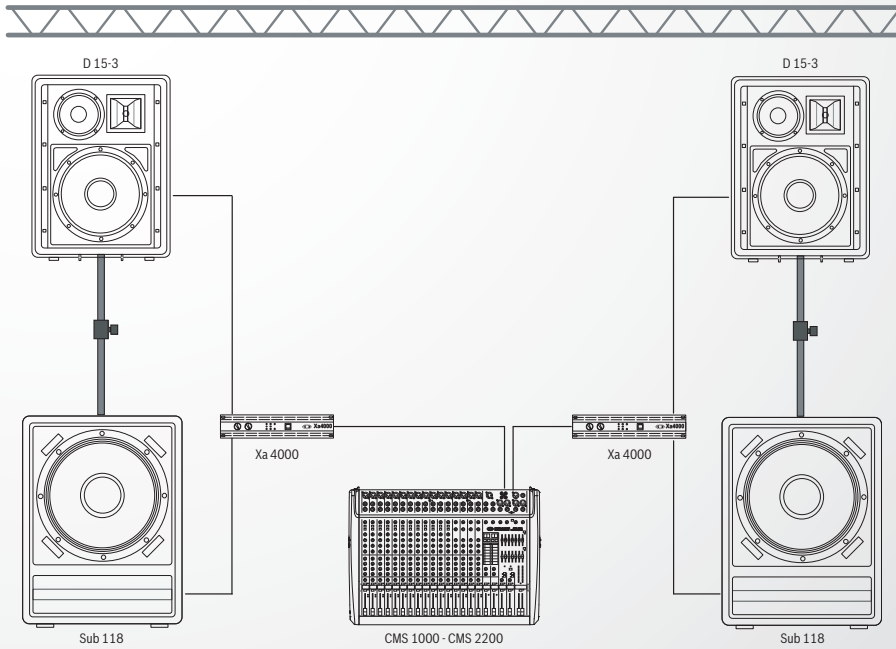

Configuration	Active 2-Way
Cabinet Types	2 x D 15-3, 2 x Sub 118
Amplifiers	2 x Xa 4000
Controllers	-
Cables	-
Accessories	2 x VPM 1500
Horizontal Coverage	2 x 90°
Total Amp Power	2 x 1100 W Sub + 2 x 900 W Top
Typical Distance	15 - 20 m
Options	-
Comments	-

D-Lite CLUBS, BARS, BISTROS

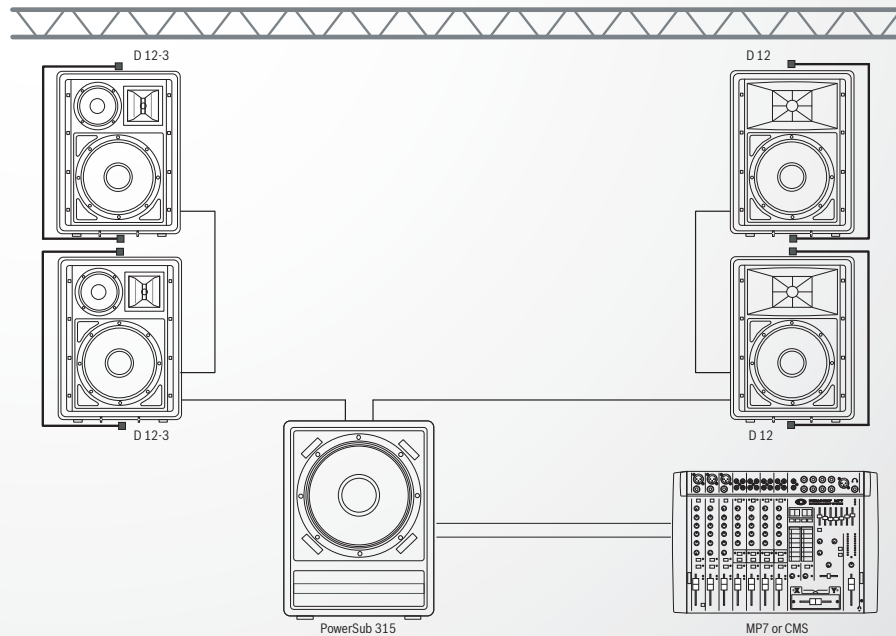

Configuration	Active 2-Way
Cabinet Types	4 x D 12 or 4 x D 12-3
Amplifiers	PowerSub 315
Controllers	-
Cables	-
Accessories	4 x MB 212 (Wall-Mount)
Horizontal Coverage	-
Total Amp Power	2 x 500 W Top, 1000 W Sub
Typical Distance	15 - 20 m
Options	2 additional passive Sub 115
Comments	D 12 in each corner, Center-Sub

D-Lite MUSICIANS, MOBILE DJ'S

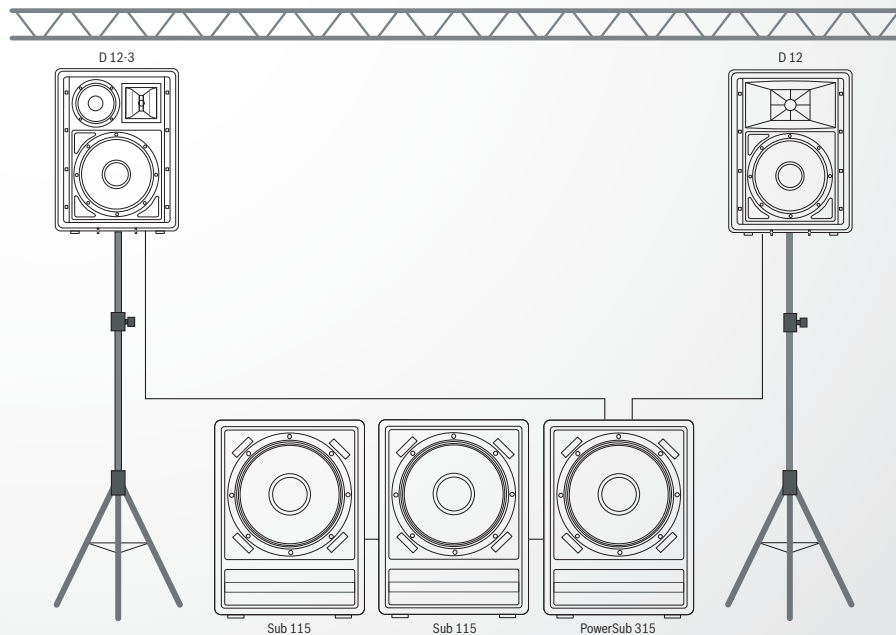

Configuration	Active 2-Way
Cabinet Types	2 x D 12 or 2 x D 12-3, 2 x Sub 115
Amplifiers	PowerSub 315
Controllers	-
Cables	-
Accessories	2 x BS 35
Horizontal Coverage	2 x 80°
Total Amp Power	2 x 500 W Top, 2 x 500W Sub
Typical Distance	15 - 20 m
Options	2 additional D 12
Comments	-

VariLine APPLICATION GUIDE

VariLine CLUB, BARS, BISTRO

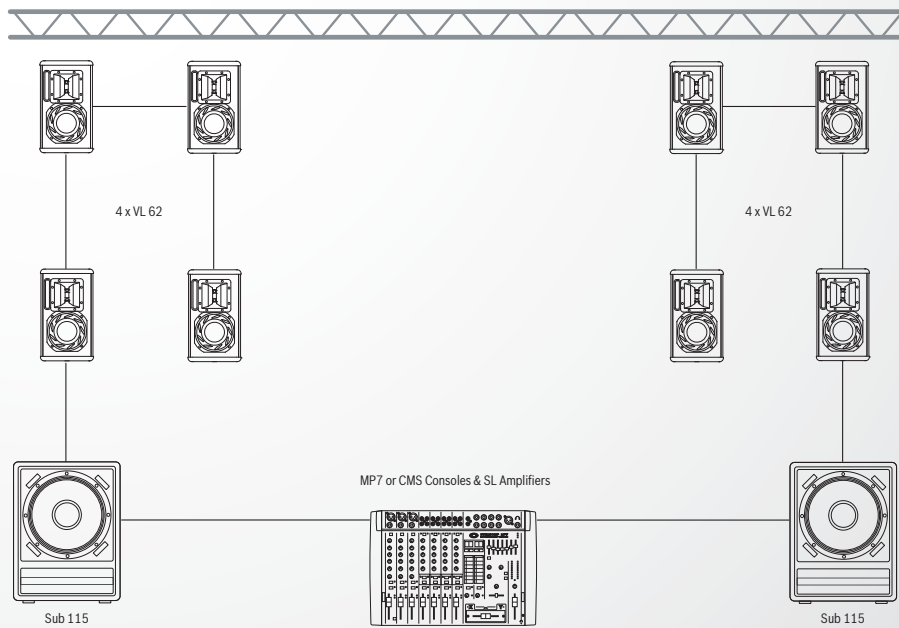

Configuration	Fullrange + Sub
Cabinet Types	8 x VL 62, 2 x Sub 115
Amplifiers	-
Controllers	-
Cables	-
Accessories	8 x WMK 10 (Wall-Mount Kit)
Horizontal Coverage	each cabinet 90°
Total Amp Power	2 x 300 W
Typical Distance	Tops 5 - 10 m
Options	-
Comments	-

VariLine APPLICATION GUIDE

VariLine CLUB, BARS, BISTRO

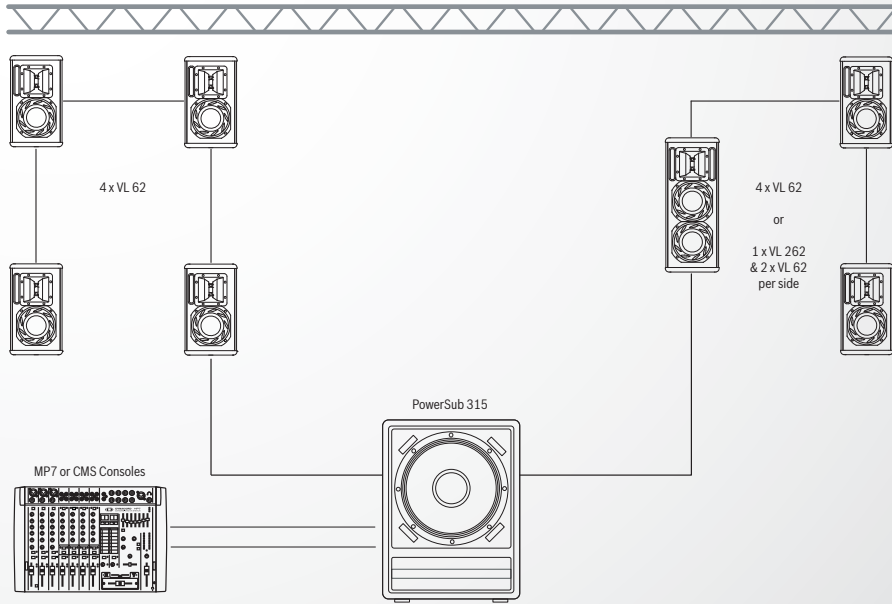

Configuration	Active 2-Way
Cabinet Types	8 x VL 62, PowerSub 315
Amplifiers	intergrated
Controllers	-
Cables	-
Accessories	8 x WMK 10 (Wall-Mount Kit)
Horizontal Coverage	each cabinet 90°
Total Amp Power	2 x 500 W Top, 1000 W Sub
Typical Distance	Tops 5 - 10 m
Options	-
Comments	-

VariLine CLUB, BARS, BISTRO

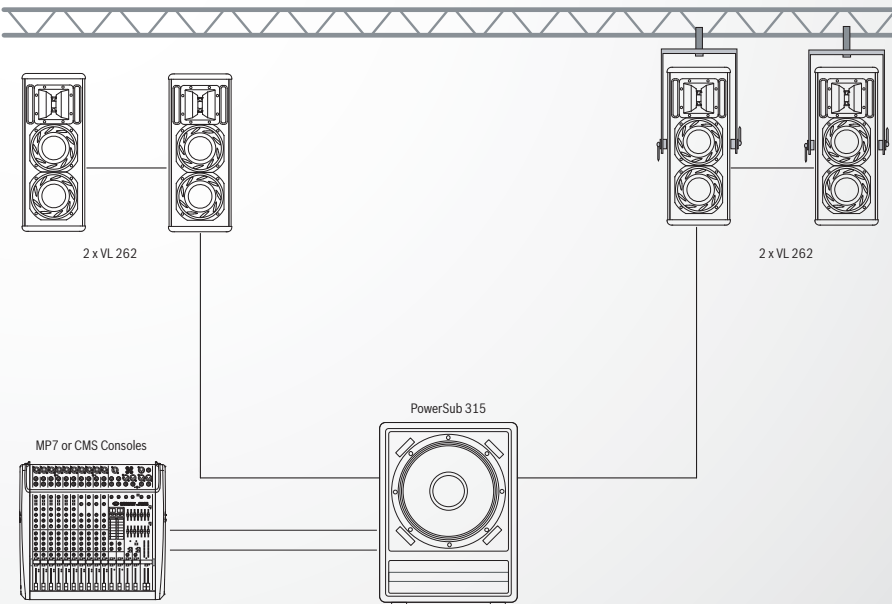

Configuration	Active 2-Way
Cabinet Types	4 x VL 262, PowerSub 315
Amplifiers	intergrated
Controllers	-
Cables	-
Accessories	4 x WMK 10 (Wall-Mount Kit) or 4 x FB-VL 262 & 4 x TC-02
Horizontal Coverage	each cabinet 90°
Total Amp Power	2 x 500 W Top, 1000 W Sub
Typical Distance	Tops 5 - 10 m
Options	-
Comments	-

VariLine COMPACT CLUB PA-SYSTEM

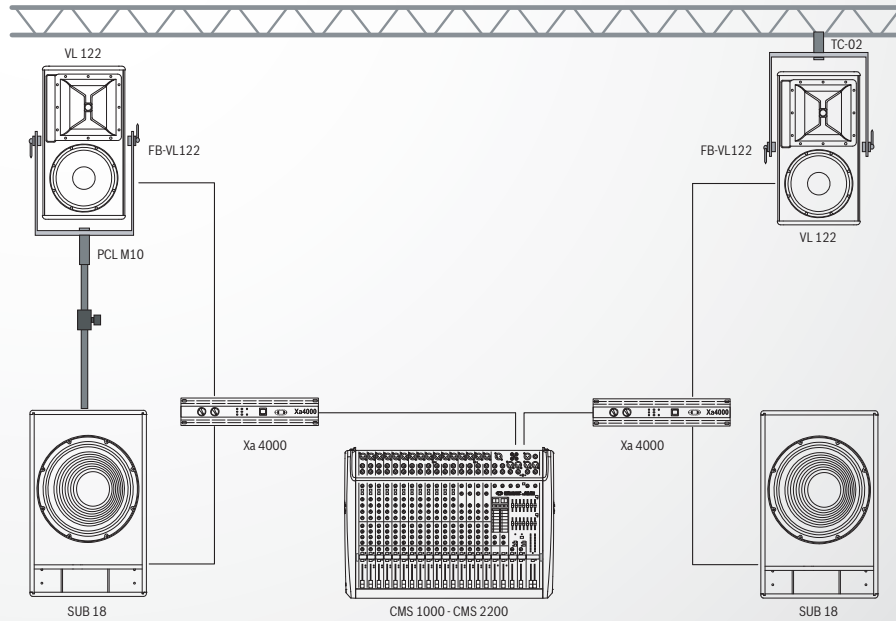

Configuration	Active 2-Way
Cabinet Types	2 x VL 122, 2 x SUB 18
Amplifiers	2 x Xa 4000
Controllers	-
Cables	-
Accessories	2 x FB-VL 122, 2 x PCL M10 or 2 x TC-02
Horizontal Coverage	each cabinet 90°
Total Amp Power	2 x 1100 W Sub, 2 x 900 W Top
Typical Distance	10 - 20 m
Options	-
Comments	-

VariLine HI-POWER CLUB PA SYSTEM

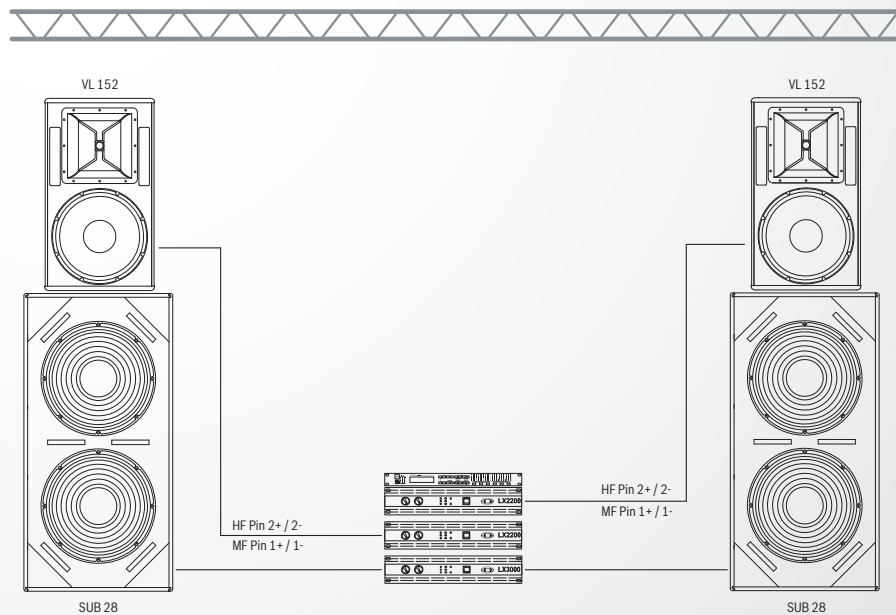

Configuration	Active 3-Way
Cabinet Types	2 x VL 152, 2 x SUB 28
Amplifiers	LX 3000, 2 x LX 2200
Controllers	DSP 260 or DSP 600
Cables	-
Accessories	-
Horizontal Coverage	each cabinet 90°
Total Amp Power	2 x 1100 W High, 2 x 1100 W Mid, 2 x 1500 W Sub
Typical Distance	-
Options	-
Comments	Amplifier Output Ch. B is connected to Output Ch. A Pin 2+ / 2-

VariLine APPLICATION GUIDE

VariLine HI-POWER PA SYSTEM

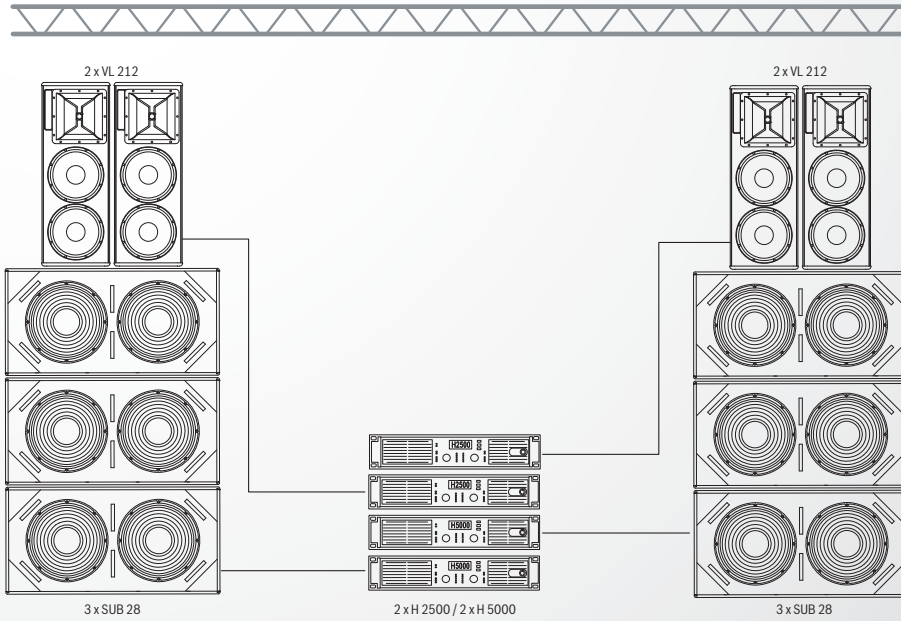

Configuration	Active 3-Way
Cabinet Types	4 x VL 212, 6 x SUB 28
Amplifiers	2 x H 5000, 2 x H 2500
Controllers	4 x RCM-26 Module
Cables	6 x 4-pole long, 8 x 4-pole short
Accessories	-
Horizontal Coverage	80° or 180° (rotatable Horns)
Total Amp Power	4 x 3000 W Sub (2.7 Ohms) 2 x 2500 W Mid (2 Ohms) 2 x 1450 W High (4 Ohms)
Typical Distance	-
Options	-
Comments	each Sub is switched to 2 x 8 Ohms, all cables 4-pole, conn. to Amp Output Ch. A



PowerMax 5 APPLICATION GUIDE

PowerMax 5 COMPACT PA SYSTEM, MEDIUM CLUBS

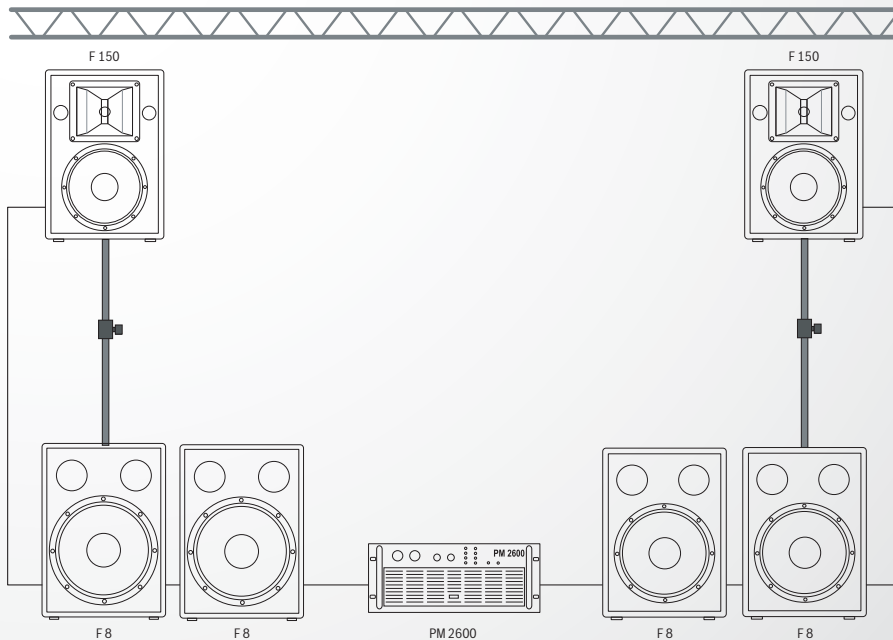

Configuration	Active 2-Way
Cabinet Types	2 x F 150, 4 x F 8
Amplifiers	1 x PM 2600
Controllers	integrated
Cables	-
Accessories	2 x VPM 1500
Horizontal Coverage	2 x 90°
Total Amp Power	2 x 600 W + 2 x 700 W Sub = 2600 W
Typical Distance	15 - 20 m
Options	PM 2600 can drive 3 x Top and 3 x Sub on each side
Comments	

Xa 2 APPLICATION GUIDE

Xa 2 HI-POWER PA-SYSTEM, LIVE BANDS

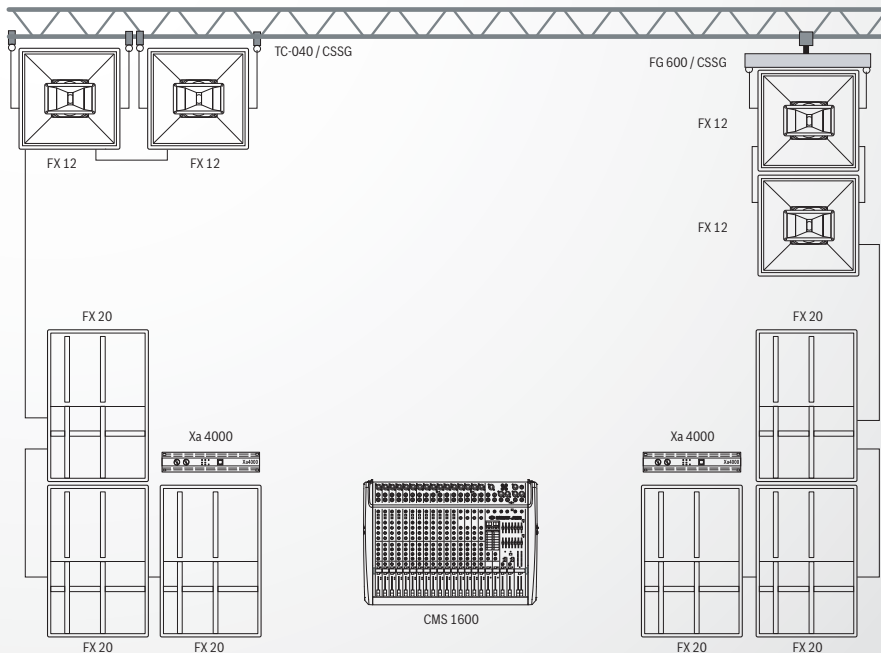

Configuration	Active 2-Way
Cabinet Types	4 x FX 12 + 6 x FX 20
Amplifiers	2 x Xa 4000
Controllers	integrated
Cables	4 x 4-pole long, 2 x 4-pole short
Accessories	TC-04, CSST
Horizontal Coverage	160° or 80°
Total Amp Power	2 x 2000 W = 4000 W
Typical Distance	25 - 35 m
Options	FG 600 (Grid)
Comments	2 x FX 12 „splayed“ for wide coverage or „in-line“ for long distance

Xa 2 HI-POWER PA-SYSTEM, MOBILE DJ'S

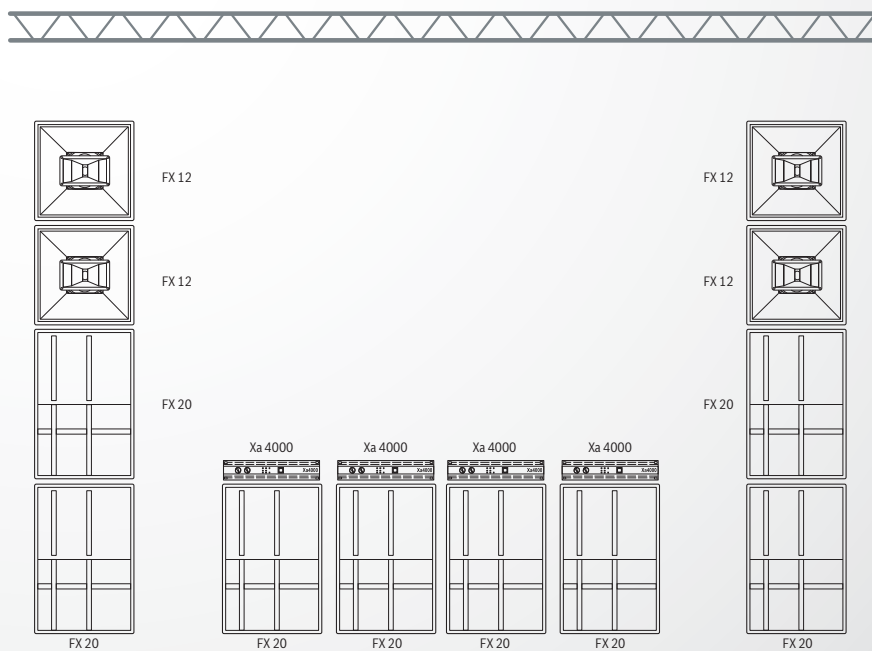

Configuration	Active 2-Way
Cabinet Types	4 x FX 12 + 8 x FX 20
Amplifiers	4 x Xa 4000
Controllers	integrated
Cables	6 x 4-pole long, 6 x 4-pole short
Accessories	-
Horizontal Coverage	2 x 80°
Total Amp Power	4 x 2000 W = 8000 W
Typical Distance	30 - 40 m
Options	-
Comments	1 x Xa 2 System per side

COBRA-2 APPLICATION GUIDE

COBRA-2 COMPACT LINE-ARRAY SYSTEM FOR SMALLER VENUES

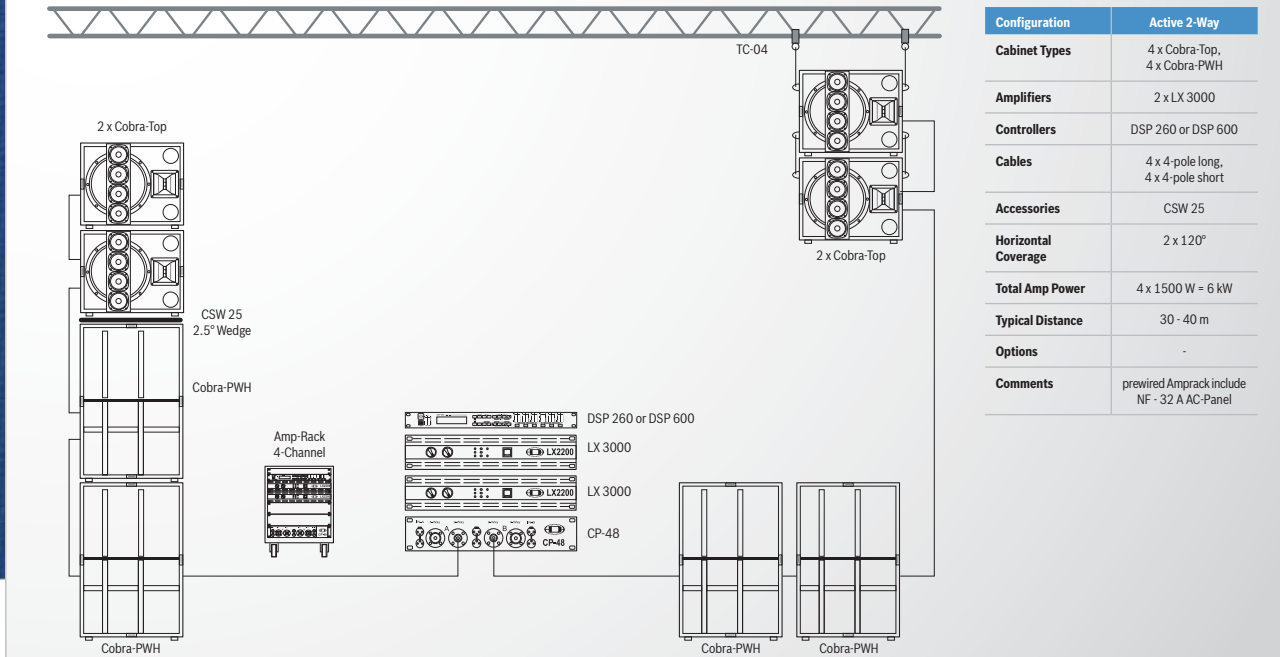

Configuration	Active 2-Way
Cabinet Types	4 x Cobra-Top, 4 x Cobra-PWH
Amplifiers	2 x LX 3000
Controllers	DSP 260 or DSP 600
Cables	4 x 4-pole long, 4 x 4-pole short
Accessories	CSW 25
Horizontal Coverage	2 x 120°
Total Amp Power	4 x 1500 W = 6 kW
Typical Distance	30 - 40 m
Options	-
Comments	prewired Amrack include NF - 32 A AC-Panel

COBRA-2 COMPACT LINE-ARRAY SYSTEM FOR MID-SIZED VENUES

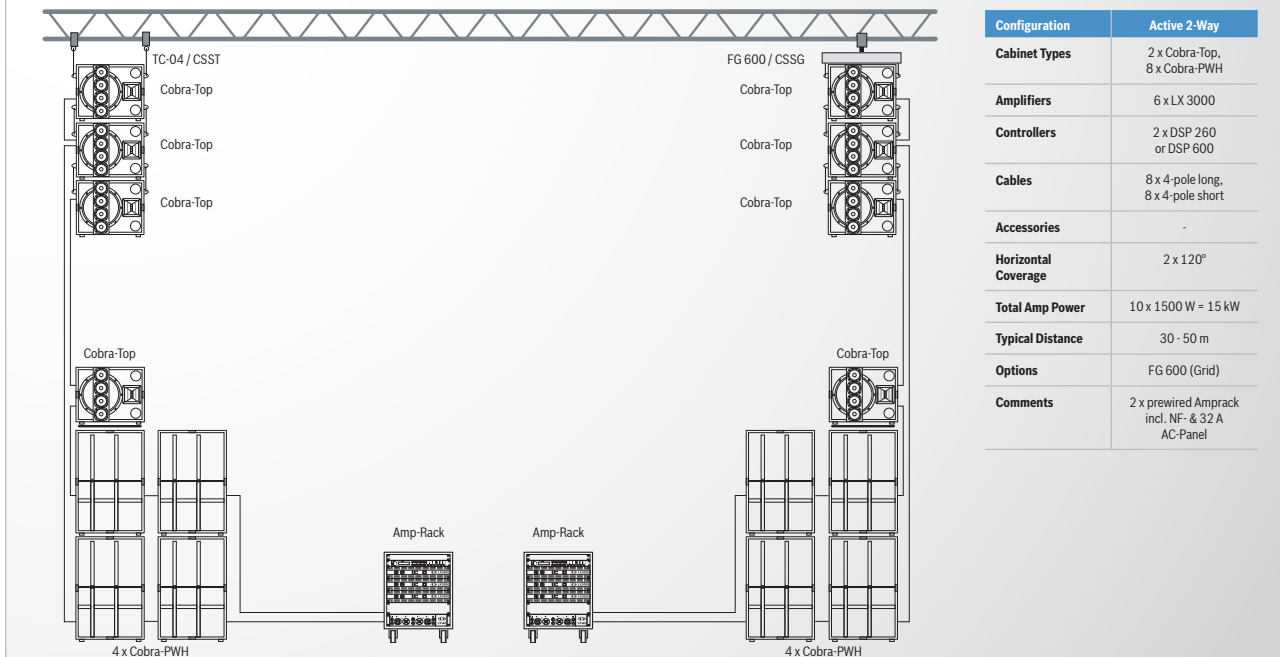

Configuration	Active 2-Way
Cabinet Types	2 x Cobra-Top, 8 x Cobra-PWH
Amplifiers	6 x LX 3000
Controllers	2 x DSP 260 or DSP 600
Cables	8 x 4-pole long, 8 x 4-pole short
Accessories	-
Horizontal Coverage	2 x 120°
Total Amp Power	10 x 1500 W = 15 kW
Typical Distance	30 - 50 m
Options	FG 600 (Grid)
Comments	2 x prewired Amrack incl. NF- & 32 A AC-Panel

COBRA-2 COMPACT LINE-ARRAY SYSTEM FOR MID-SIZED VENUES

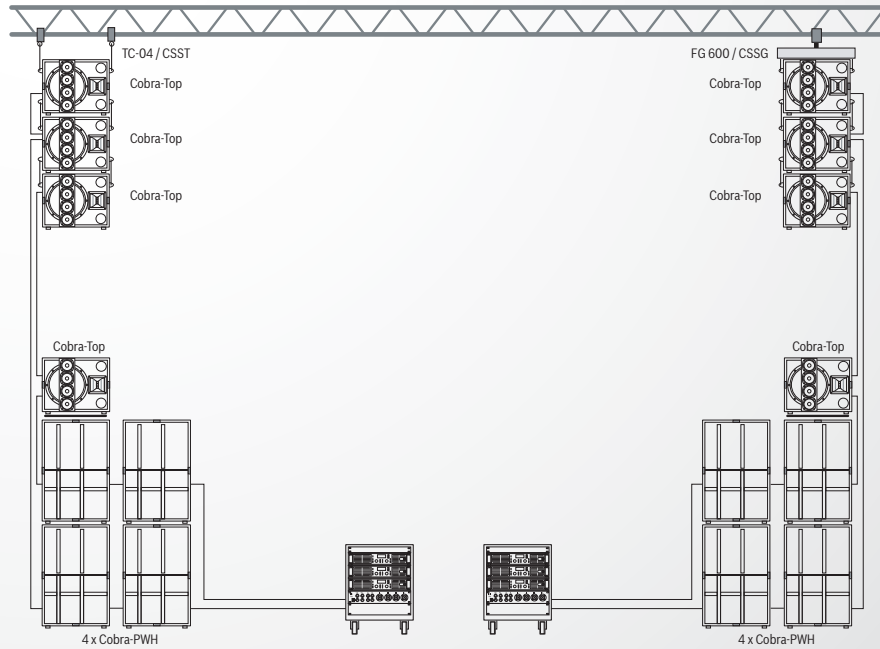

Configuration	Active 2-Way
Cabinet Types	2 x Cobra-Top, 8 x Cobra-PWH
Amplifiers	6 x H 2500
Controllers	6 x RCM-26
Cables	8 x 4-pole long, 8 x 4-pole short
Accessories	-
Horizontal Coverage	2 x 120°
Total Amp Power	12 x 2500 W= 30 kW
Typical Distance	30 - 50 m
Options	FG 600 (Grid)
Comments	2 x prewired Amprack

COBRA-4 APPLICATION GUIDE

COBRA-4 LINE-ARRAY SYSTEM FOR MID-SIZED VENUES

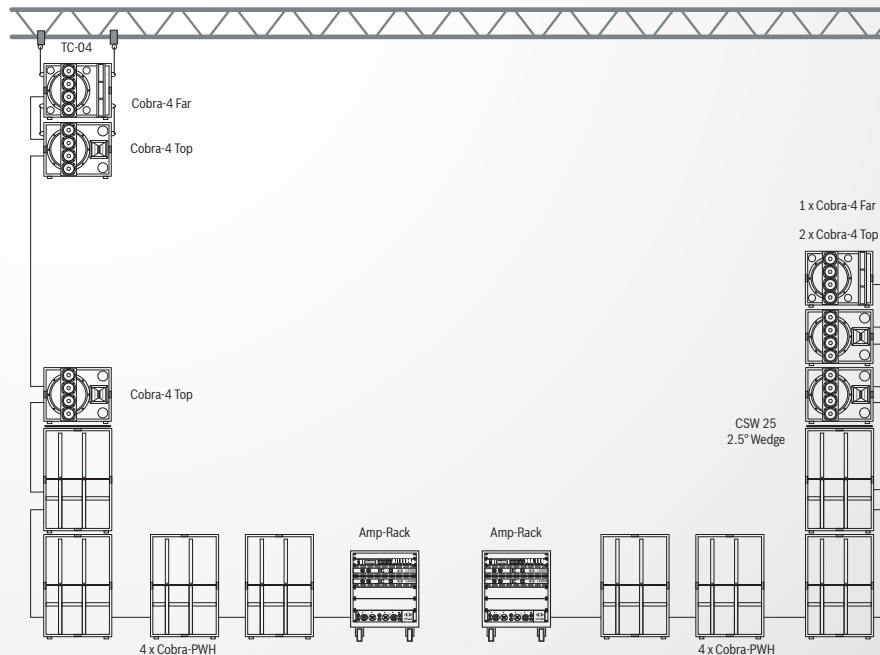

Configuration	Active 4-Way
Cabinet Types	2 x Cobra-4 Far, 4 x Cobra-4 Top, 8 x Cobra-PWH
Amplifiers	4 x LX 3000
Controllers	2 x DSP 260 or DSP 600
Cables	6 x 8-pole long, 8 x 8-pole short
Accessories	Rigging Straps CSST, CSSM
Horizontal Coverage	2 x 120°
Total Amp Power	2 x 2100 W, 6 x 1800 W= 15kW
Typical Distance	40 - 80 m
Options	-
Comments	2 x prewired Amprack incl. NF & AC-Panel

COBRA-4 APPLICATION GUIDE

COBRA-4 LINE-ARRAY SYSTEM FOR MID-SIZED VENUES

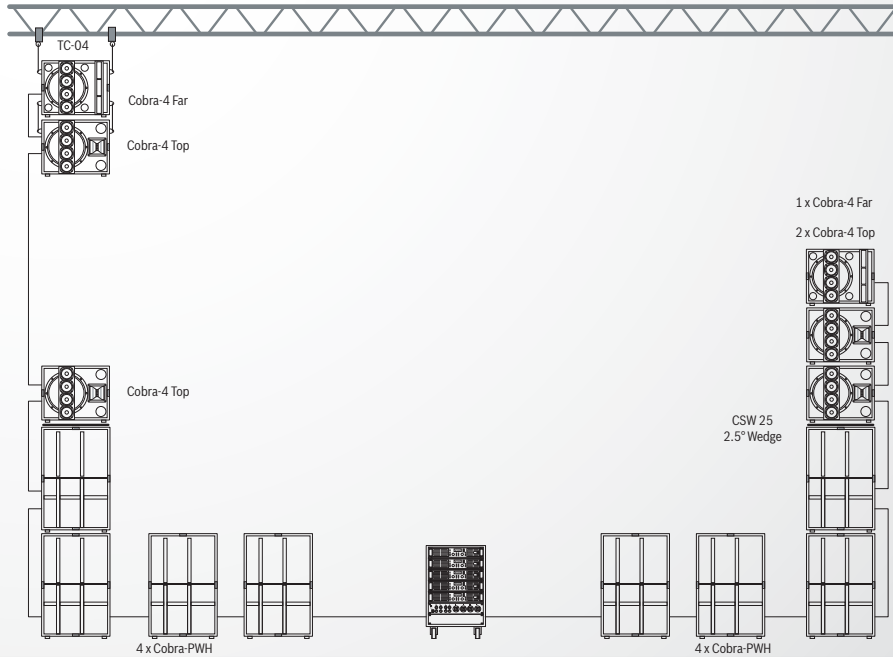

Configuration	Active 4-Way
Cabinet Types	4 x Cobra-4 Far, 4 x Cobra-Top, 8 x Cobra-PWH
Amplifiers	5 x H 5000
Controllers	5 x RCM-26
Cables	6 x 8-pole long, 8 x 8-pole short
Accessories	Rigging Straps CSST, CSSM
Horizontal Coverage	2 x 120°
Total Amp Power	10 x 2500 W = 25 kW
Typical Distance	40 - 80 m
Options	-
Comments	-



COBRA-4 LINE-ARRAY SYSTEM FOR LARGER VENUES

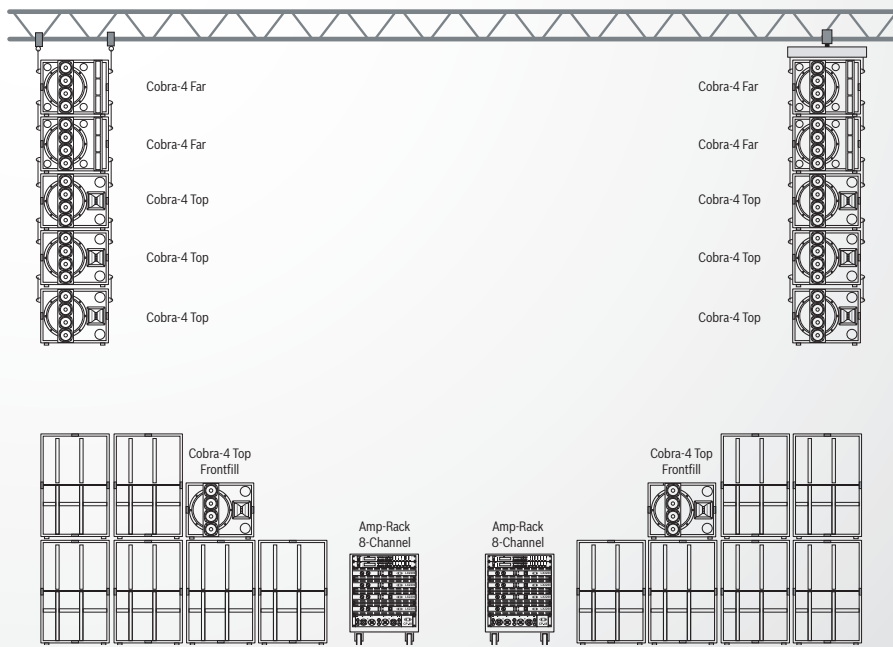

Configuration	Active 4-Way
Cabinet Types	4 x Cobra-4 Far, 8 x Cobra-Top, 12-16 x Cobra-PWH
Amplifiers	8 x LX 3000
Controllers	4 x DSP 260 or DSP 600
Cables	12 x 8-pole long, 16 x 8-pole short
Accessories	-
Horizontal Coverage	2 x 120°
Total Amp Power	4 x 2100 W + 12 x 1800 W = 30kW
Typical Distance	40 - 80 m
Options	FG 600 (Grid)
Comments	System can be split into two separate Systems

COBRA-4 LINE-ARRAY SYSTEM FOR LARGER VENUES

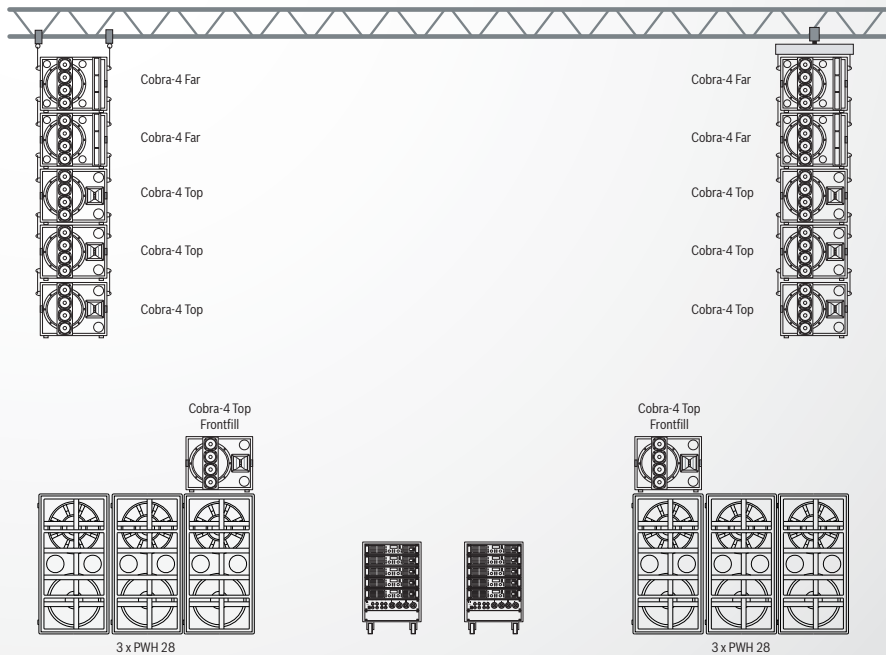

Configuration	Active 2-Way
Cabinet Types	4 x Cobra-4 Far, 8 x Cobra-Top, 6 x PWH 28
Amplifiers	10 x H 5000
Controllers	10 x RCM-26
Cables	12 x 8-pole long, 16 x 8-pole short
Accessories	-
Horizontal Coverage	2 x 120°
Total Amp Power	20 x 2500 = 50 kW
Typical Distance	40 - 80 m
Options	FG 600 (Grid)
Comments	System can be split into two separate Systems



AMERICAS

HEADQUARTERS AMERICAS

Bosch Security Systems, Inc.

12000 Portland Ave South,

Burnsville, MN 55337, USA

USA-Tel: 1 800 392 3497

Fax: 1 800 955 6831

Canada-Tel: 1 866 505 5551

Fax: 1 866 336 8467

Latin America-Tel: 1 952 887 5532

Fax: 1 952 736 4212

EMEA

HEADQUARTERS EUROPE, MIDDLE-EAST & AFRICA

Bosch Sicherheitssysteme GmbH

Werner-von-Siemens-Ring 10

85630 Grasbrunn, Germany

Contact & Visitor Address

EVI Audio GmbH

Sachsenring 60

94315 Straubing, Germany

Tel: +49 9421 706 0

Fax: +49 9421 706 265

FRANCE

EVI Audio France S.A.S

Tel: +33 1 6480 0090

Fax: +33 1 6006 5103

MIDDLE EAST

Robert Bosch Middle East FZE

Tel: +97 14 212 3300

Fax: +97 14 212 3388

ASIA & PACIFIC

HEADQUARTERS APR

Robert Bosch (SEA) Pte Ltd.

11 Bishan St. 21

Singapore 573943

Tel: +65 6571 2534

Fax: +65 6571 2699

AUSTRALIA

Bosch Security Systems Pty Ltd.

Tel: +61 2 9683 4752

Fax: +61 2 9890 5928

CHINA

Bosch (Shanghai) Security

Systems Ltd. (Shanghai) Co., Ltd.

Tel: +86 21 6317 2155

Fax: +86 21 6317 3025

INDIA

Bosch Limited

Tel: +91 80 4176 8378

Fax: +91 80 4176 8263

JAPAN

EVI Audio Japan Ltd.

Tel: +81 3 5485 4427

Fax: +81 3 5485 4428

THAILAND

Robert Bosch Limited

Tel: +662 639 3111

Fax: +662 631 2030

KOREA

Robert Bosch Korea Ltd.

Tel: +82 31 270 4765

Fax: +82 31 270 4601

TAIWAN

Robert Bosch Taiwan Co., Ltd.

Tel: +886 2 2515 5388 Ext. 2688

Fax: +886 2 2515 5399

VIETNAM

Robert Bosch Vietnam Co., Ltd.

Tel: +84 8 62583690

Fax: +84 8 62583693

INDONESIA

PT Robert Bosch

(Security Systems)

Tel: +62 21 5210600

Fax: +62 21 5214848