

Dynaflex® Elastomeric Flexible Couplings

Featuring: Dynaflex® Shear-Type Couplings
 Dynaflex® Spool-Type Couplings
 Dynaflex® Bushing-Type Couplings
 Dynaflex® LCR Series Couplings
 Dynaflex® LCD Series Couplings

Efficient power transmission and driveline component durability are among powertrain designers' most important concerns. Increased durability and up-time are two characteristics demanded by purchasers of today's complex and expensive machinery. These demands can only be met with reliable, trouble-free, smooth-running powertrains free from damaging loads which compromise component life.

Powertrain component life is determined by the load spectrum each component will experience during the machine's service life. Reciprocating engines, such as spark-ignited gasoline and compression-ignited diesels, produce alternating torque loads which, when superimposed on the steady driving torque, create alternating stresses in driveline system components which shorten component life and reliability. High transient start-up torques and misalignment caused by skewed rotational axes between driver and driven in electric motor, hydraulic and pneumatic drives also cause high imposed forces on driven components. These unwanted forces loosen bolted joints and cause spline fretting, clutch disk wear, bearing failure, gear tooth fatigue and shaft fatigue, among an array of other problems.

Elastomeric flexible couplings solve these problems. They prolong driveline component life because they reduce the magnitude of imposed loads, attenuate vibration in multiple planes, accommodate misalignments in multiple planes, and act as barriers impeding noise created by meshing gears, engaging clutches, etc.

Elastomeric flexible couplings are also maintenance-free. They require no lubrication or other maintenance throughout their service life. Among the large variety of coupling types available, LORD Corporation's elastomeric couplings offer the most comprehensive package of benefits available to the powertrain designer. LORD Corporation's product lines include five different elastomeric coupling styles which cover a wide range of application requirements.

Application

Application requirements suggest the coupling style needed to optimize powertrain performance and component longevity. Misalignment accommodation, torsional vibration isolation, transient shock dissipation and required service life are important parameters to consider when selecting a coupling to fill specific application requirements.

LORD engineers can assist you with selecting an appropriate coupling type and configuration. With extensive analytical capability and years of experience in designing products for powertrain vibration, shock and motion control, LORD engineers offer everything from simple application assistance to complex system analysis and specialized product design.

Torsional vibration, transient shock and misalignment load analyses require specialized computer programs and engineering experience. LORD engineers can analyze your system and recommend the right solution, whether it's a selection from the standard product line or a custom design.

LORD Corporation's standard product lines of elastomeric flexible powertrain couplings are presented in the following sections. Many variations of standard products are available, but not listed as 'standard.' Main drive, fan drive, PTO and accessory drive couplings are available in a host of custom designs and variations of standard products. LORD engineers are ready to help you meet your specific application requirements with custom designs where necessary.

Product Lines

LORD offers five major lines of elastomeric flexible couplings. Standard lines are presented on the following pages. In addition to the standards listed, many variations are available in each product line.

Dynaflex® Shear-Type Couplings

LORD Dynaflex Shear-Type Coupling features a durable elastomeric flexing element bonded between two hubs. These couplings are designed for fractional horsepower applications requiring smooth starting transition, torsional vibration isolation and misalignment accommodation. Typical applications are small electric motor drives, low-torque mechanisms, power take-offs and auxiliary equipment drives.

Dynaflex® Spool-Type Couplings

LORD Dynaflex Spool-Type Couplings can be arranged in a variety of configurations to create a wide range of torque-transmitting capability. Elastomeric spool elements can be purchased in lot sizes for customer-assembled coupling designs, or LORD can provide a complete coupling assembly to meet specific application requirements. Typical applications are large drives requiring high torque capacity and low torsional stiffness.

Dynaflex® Bushing-Type Couplings

LORD Dynaflex Bushing-Type Couplings are bonded elastomeric elements designed for use in multiple element coupling configurations where high torque capacity is required. Bushings are available in a variety of stiffnesses. They can be purchased in lots for customer-assembled designs, or LORD can provide complete coupling assemblies designed to meet your specific application requirements. Applications requiring high torque/high torsional stiffness, but angular, axial and parallel misalignment accommodation can be designed using these bushings in a variety of configurations including parallel and series arrangements.

Dynaflex® LCR Series Couplings

LORD Dynaflex LCR Series Couplings features an elastomeric ring with bonded, bush-type inserts allowing various attachment configurations. These couplings offer a soft torsional spring rate which permits smooth transmission of driving torque while attenuating shock torques and providing excellent misalignment accommodation. These couplings are used in PTO drives where torsion and cocking flexibility are required. They can be mated with a variety of hub configurations. Special high-torque designs are available, as well as custom designs to meet special application requirements.

Dynaflex® LCD Series Couplings

LORD Dynaflex LCD Series Couplings are the ultimate coupling for reciprocating engine drives. This coupling features a bonded elastomeric flexing element which is radially precompressed into a flanged outer housing. This design produces a low torsional stiffness for maximum isolation of engine firing-pulse-induced torsional disturbances, torque overload slip protection, misalignment accommodation, superior shock pulse attenuation and fatigue life, and is adaptable to a variety of drive attachment designs. Custom designs are available to fit nearly every SAE flywheel configuration available from most engine manufacturers.

Coupling Application Guide

	Dynaflex Shear-Type	Dynaflex Spool-Type	Dynaflex Bushing-Type	Dynaflex LCR Series	Dynaflex LCD Series
Horsepower	Rated: 1/50 to 1	Rated: 50 to 1000	Rated: 10 to 600	Rated: 4 to 135	Rated: 75 to 2000
Best Application Area	Low-frequency vibration, multidirectional misalignment	Low-frequency vibration, high-power drive systems	Multidirectional misalignment, high capacity	Large misalignment, safetied drive requirements	Diesel engines, low-frequency vibration, multidirectional misalignment
Outstanding Capabilities	Effectively accommodates combinations of misalignment, high torsional resilience	Versatility in design for exact application requirements (stiffness and capacity)	High torque capacity versus size	Angular misalignment capability	Fits many standard flywheels, high torsional
Versatility Factor	Widest application potential of all elastomeric couplings	Capacity and resilience can be varied by changing number and type of spool	Numerous combinations possible simply by changing flexing elements	Torsional spring rate varied by changing modulus or wall thickness	Large horsepower, high horsepower capacity
Fail-Safe Characteristics	Easily incorporated	Easily incorporated	Inherent	Inherent	Slip-torque feature

Dynaflex Elastomeric Flexible Couplings

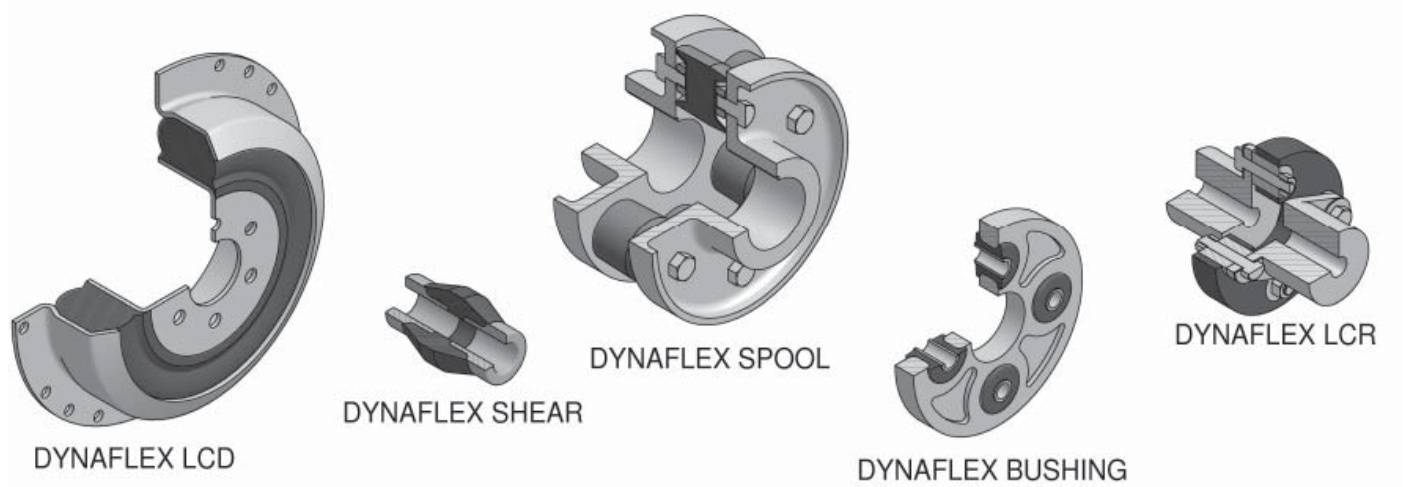

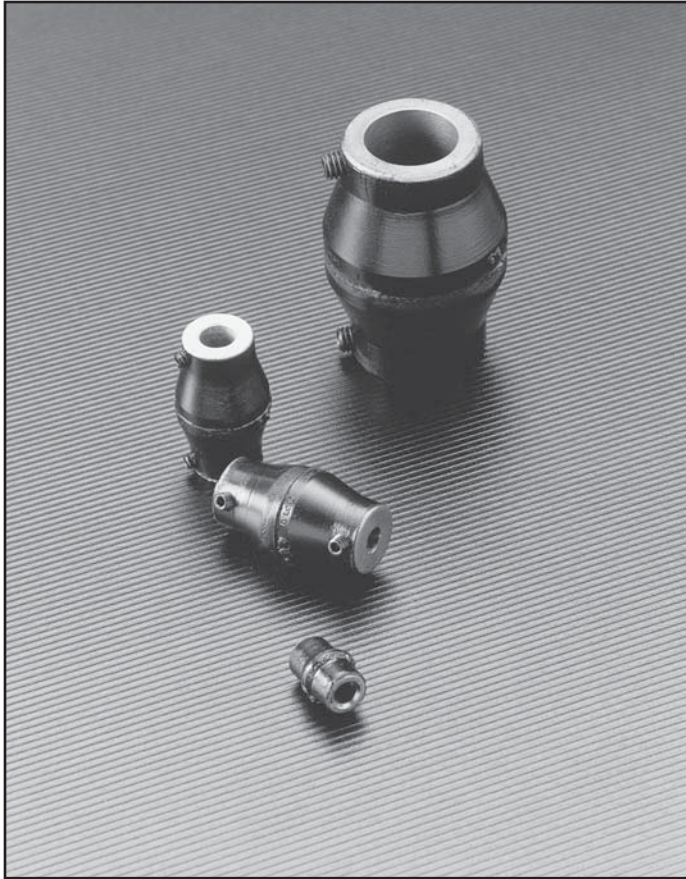

Dynaflex® Shear-Type Couplings

Rated: 1/50 to 1 hp at 1750 rpm

LORD Dynaflex Shear-Type Couplings are compact, one-piece flexible couplings economically constructed to isolate low-frequency vibration and accommodate multi-directional misalignment.

These couplings reduce the adverse effects of transient shock torques, torsional vibration, noise and misalignment associated with small equipment drivelines. This results in longer service life, smoother, quieter operation, less maintenance, and lower cost for your end product.

Shear-Type flexible couplings are useful in many small equipment driveline applications. Multi-directional misalignment capabilities make them ideally suited for fractional horsepower drivelines demanding noise reduction, vibration isolation and maintenance-free operation.

Typical applications include:

- Information Systems – Motor drive, printer rollers, indexing devices, linear actuator, drives and card sorters
- Hospital Bed – Actuator drive
- Dynamometer – Driveline
- Tachometer – Driveline
- Pumps, Blowers, Compressors – Driveline

Features and Benefits

- High torsional deflection
- Easy installation
- Versatile application potential - fractional horsepower couplings are available in a range of sizes to permit matching a specific coupling to your application.
- One-piece construction – convenient for small equipment with fractional horsepower requirements. Specified torque rating allows 15° angular deflection for excellent vibration isolation.
- Multi-directional misalignment accommodation – elastomeric flexibility accommodates misalignments up to 1/32 inch parallel, 2° angular.
- Vibration isolation – low torsional stiffness is achieved with the shear-type flexible coupling because the rubber is loaded in shear. This allows for low system natural frequencies and excellent driveline disturbances.
- Shock protection – torsional shock loads are attenuated by torsional deflection of the elastomer. Torsional flexibility smooths out rotational disturbances and protects system components from early fatigue failure.
- Noise reduction – no metal-to-metal contact; elastomeric barrier reduces gear noise, transmission and motor hum between shifts.
- Maintenance-free – elastomer flexibility accommodates all motion without metal-to-metal wear, eliminates the need for lubrication.
- Long service life – Dynaflex Shear-Type Couplings have proven themselves under demanding service conditions. Elastomers resist effects of abrasive materials, oil and grease.
- Attachment – shear-type flexible couplings are available in an assortment of bore sizes. Refer to Table 1.
- Constant velocity – inherent design properties produce a rotational constant velocity.

Dynaflex Shear-Type Couplings

Table 1 – Specifications and Dimensions

Coupling Part Number	Standard Bore Diameters		C (in)	D Ref. (in)	E Ref. (in)	F (in)	HP at 1750 rpm Ref.	Torque Rating (lb-in)	Static Torsional Stiffness (lb-in/deg) ±20%	Set Screw Size
	A (in)	B (in)								
SK-1947-6	0.125	0.125	0.44	0.56	0.36	0.81	1/50	0.8	0.053	5/40
SK-1947	0.187	0.187								
SK-1947-19	0.187	0.250								
SK-1947-29	0.250	0.250								
J-1211-1-2	0.187	0.187	0.63	0.81	0.56	1.38	1/16	2.50	0.17	10/24
J-1211-1-1	0.250	0.250								
J-1211-2-2	0.250	0.250	0.75	1.00	0.72	1.75	1/8	5	0.33	10/24
J-1211-2-11	0.250	0.312								
J-1211-2-6	0.250	0.375								
J-1211-2-3	0.312	0.312								
J-1211-2-12	0.312	0.375								
J-1211-2-1	0.375	0.375								
J-1211-3-4	0.312	0.312	0.88	1.25	0.88	2.13	1/4	10	0.66	1/4-20
J-1211-3-14	0.312	0.375								
J-1211-3-12	0.312	0.500								
J-1211-3-2	0.375	0.375								
J-1211-3-8	0.375	0.500								
J-1211-3-1	0.500	0.500								
J-1211-4-2	0.375	0.375	1.00	1.38	0.91	2.25	1/3	13	0.87	1/4-20
J-1211-4-35	0.375	0.500								
J-1211-4-11	0.375	0.625								
J-1211-4-14	0.500	0.500								
J-1211-4-4	0.500	0.625								
J-1211-4-1	0.625	0.625								
J-1211-5-3	0.500	0.500	1.13	1.63	1.00	2.50	1/2	20	1.33	1/4-20
J-1211-5-4	0.500	0.750								
J-1211-5-2	0.625	0.625								
J-1211-5-1	0.750	0.750								
J-1211-6-12	0.500	0.500	1.38	1.81	1.05	2.69	3/4	30	2.00	5/16-18
J-1211-6-18	0.625	0.625								
J-1211-6-14	0.625	0.750								
J-1211-7-16	0.500	0.750	1.50	2.00	1.11	2.88	1	40	2.66	5/16-18
J-1211-7-9	0.625	0.625								
J-1211-7-3	1.00	1.00								

Notes: Maximum recommended misalignment - 1/32 inch parallel, 2° angular. Intrusion should not exceed "E" bore length dimensions.

Standard Construction: Hubs - steel; Bores - as listed; Set Screws - one per hub furnished but not installed; Flexing Element - neoprene.

Figure 1 – Part Dimensions

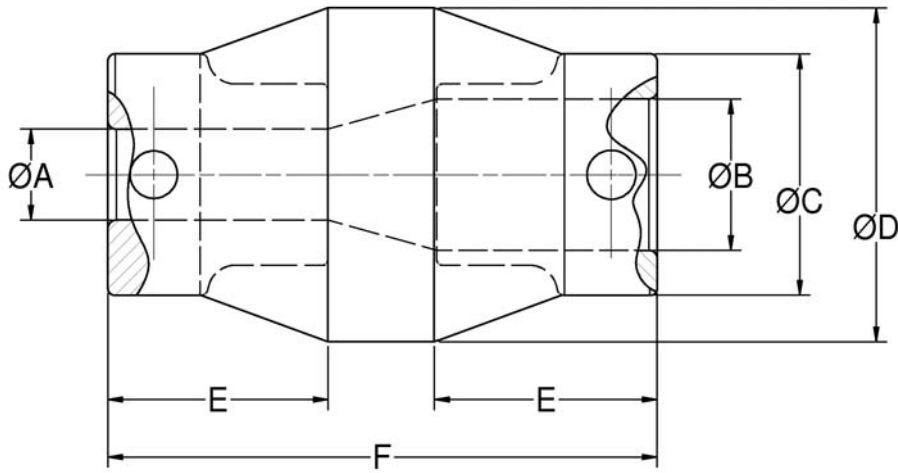
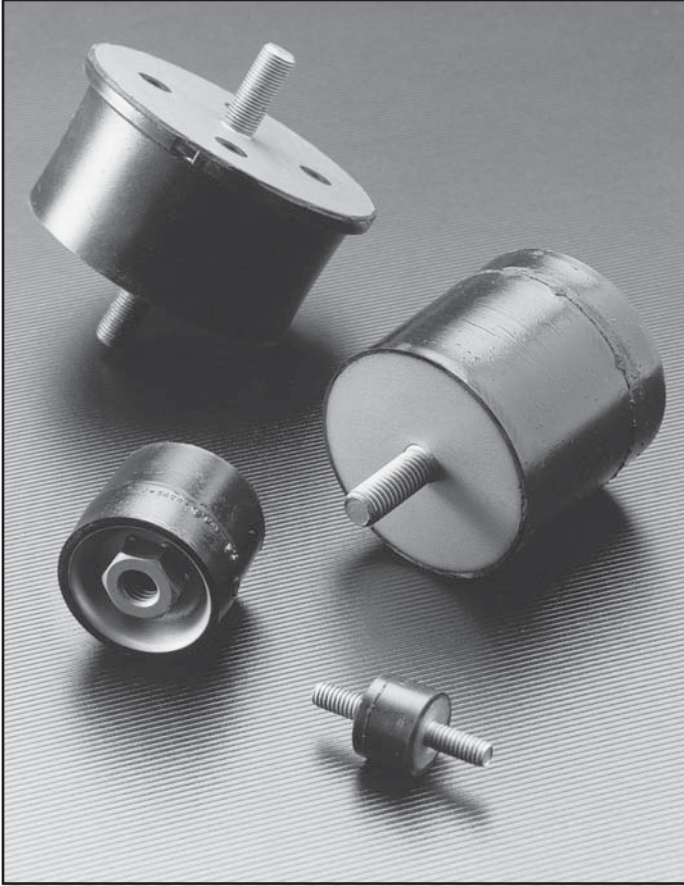

Table 2 – Standard Bore Tolerances

Bore Sizes	Tolerance
from 0.000 to 0.499	+ 0.001 - 0.000
from 0.500 to 0.749	+ 0.0015 - 0.0000
from 0.750 to 1.499	+ 0.002 - 0.000



Dynaflex® Spool-Type Couplings

Rated: 5 to 1000 hp at 2000 rpm

LORD Dynaflex Spool-Type Couplings provide excellent protection against destructive torsional vibration in high-torque drive systems.

These couplings are customer-assembled, using bonded flexing spools from LORD, and bolted between customer-supplied metal hubs. Spools should be placed around recommended bolt circle on hub. Bonded spools can be installed or replaced with minimum effort. Coupling assembly has torsional deflection of 2° under rated torque.

Dynaflex Spool-Type Couplings

Table 1 – Specifications and Dimensions

Spool Part Number	A Diameter	B Thickness	C	Thread Attachment	Minimum Bolt Circle Diameter for Number of Mounts (in)									
					3	4	5	6	7	8	9	10	11	12
J-4624-1	1.00	0.75	0.38	1/4-20-2A	1.20	1.42	1.70	2.00	2.30	2.62	2.92	3.24	3.56	3.86
J-3424-2	2.00	2.12	0.40	1/2-13-2B	2.30	2.82	3.40	4.00	4.60	5.22	5.84	6.46	7.50	7.72
J-5425-1	3.19	3.00	1.25	1/2-13-2A	3.62	4.41	5.30	6.25	7.18	8.18	9.12	10.20	11.00	12.10
J-5682-1	4.48	2.25	1.25	1/2-20-2A	5.10	6.20	7.45	8.75	10.10	11.50	12.80	14.30	15.70	17.00

Notes: Maximum recommended misalignment - 1/32 inch parallel, 1° angular.
Coupling permits wide latitude in shaft lengths. However, sufficient spacing between shaft ends should be provided to allow for shaft end play.

It is suggested that all designs for Spool-Type Flexible Couplings be reviewed with LORD Corporation.

Construction: Rubber elements - LORD does not supply hubs, elements only;
Metal parts - steel; Flexing element - environmental-resistant elastomer.

Table 2 – Coupling Configuration Capacity Chart

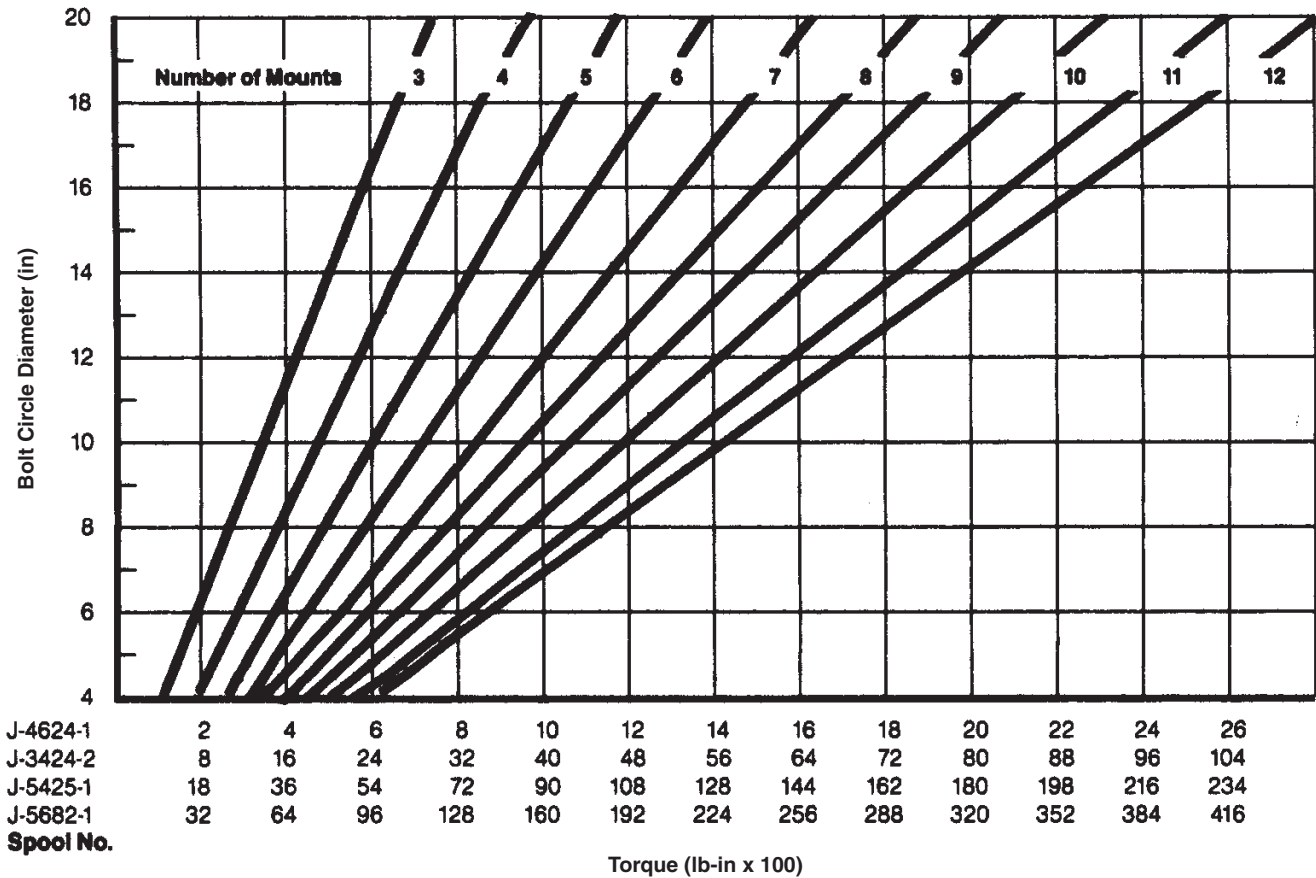

Figure 1 – Part Dimensions - J-4624-1

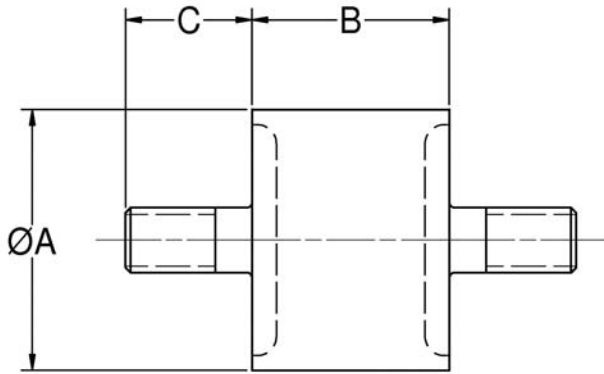

Figure 2 – Part Dimensions - J-3424-2

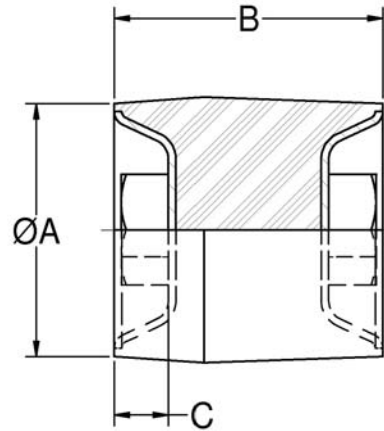

Figure 3 – Part Dimensions - J-5425-1

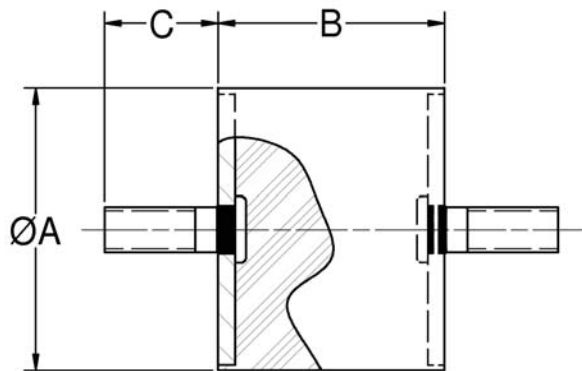

Figure 4 – Part Dimensions - J-5682-1

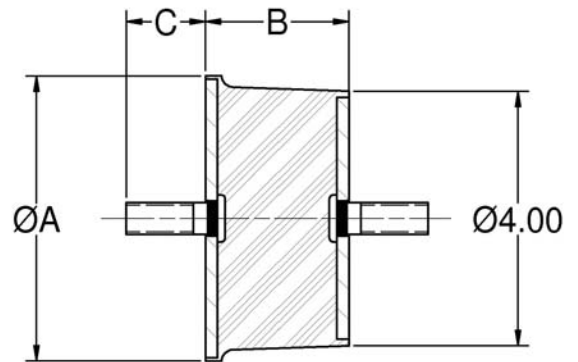
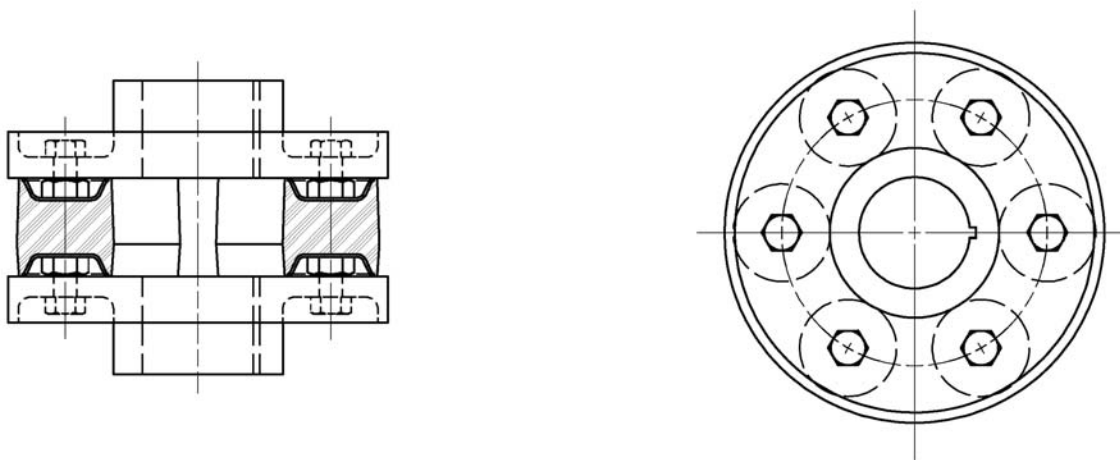
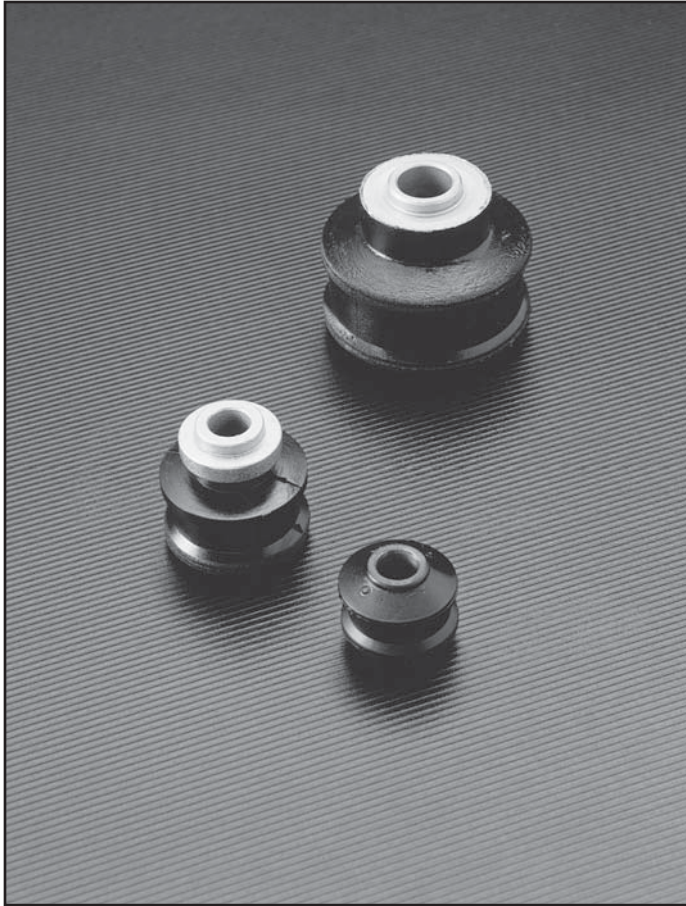

Figure 5 – Typical Assembly with Bonded Flexing Spools





Dynaflex® Bushing-Type Couplings

Rated: 10 to 600 hp at 2000 rpm

LORD Dynaflex Bushing-Type Couplings accommodate misalignment, cushion torsional shock, and do not generate or transmit noise. Since relative motion is taken in the elastomer rather than sliding metal surfaces, no lubricant is involved or ever required. Dirt and grit cannot effect the coupling bushings. The elastomer has been compounded to provide long service life.

Typical applications include driveline installations where multi-directional misalignment must be accommodated and torque loads are medium to high.

Specification, selection and dimension information provided on the following pages facilitate design of the coupling assembly. The bushings are standard parts, and the flanges can be supplied by the end user or by LORD as a special design.

Selection Guide

Compression bushing-type couplings are assembled by pressing the elastomeric bushings into sockets of a coupling flange. Once assembled, the coupling can be used two ways:

• **Parallel Arrangement**

The driving shaft can be connected to all of the bushings, and the driven shaft connected to the coupling flange. This arrangement loads all bushings in parallel and produces maximum torque capacity and a less resilient coupling.

• **Series Arrangement**

This arrangement requires an even number of bushings per flange. Mating flanges of the driving and driven shafts are attached to alternate bushings. This arrangement transmits the torque through the bushings in an N x N series arrangement, thereby making the torque capacity one-half of the parallel arrangement. The coupling is also more flexible.

When high torque and small space are the controlling factors, the parallel arrangement is recommended. When misalignment is the controlling factor, the bushings should be applied in series arrangement.

Table 1 provides selection criteria for parallel arrangement, Table 2 provides data for the series arrangement. Bushing selection is dependent upon torque requirements, angular, parallel and axial misalignments, as well as bolt circle diameter, number of bushings and bushing size. The torque values shown on the charts are nominal. The bushings are capable of withstanding higher torques due to the shock loads or other short duration surges.

Torsional Flexibility

Bushing-type couplings are relatively stiff torsionally compared to other elastomeric couplings. The torsional spring rate of a coupling assembly can be calculated by using the equation and data provided on the curves.

Example

Required torque capacity – 3400 lb-in

Misalignment – Angular – 1.75°

Axial – 1/8 in

Parallel – 1/32 in

Proposed Coupling – 7 x 7 Series, J-5737-1, (N = 7)

8 in bolt circle

$$K_{\theta} = \frac{N}{2} R^2 K_R$$

$$K_{\theta} = \frac{7}{2} (4)^2 4000 = 224,000 \text{ lb-in/rad.}$$

Caution: Shaft length must be considered for potential whirl problems.

Recommended Misalignment Limits

	Misalignment	Bushing Arrangement	
		Parallel	Series
Single Coupling	Angular	1°	1.75°
	Parallel	1/64 in	1/32 in
	Axial	±1/16 in	±1/8 in
Double Coupling	Angular	2°	3.5°
	Parallel	3/16 to 1/2 in*	3/8 to 1 in*
	Axial	±1/8 in	±1/4 in

* Dependent on shaft length (10 to 30 in).

Figure 1 – Parallel Arrangement

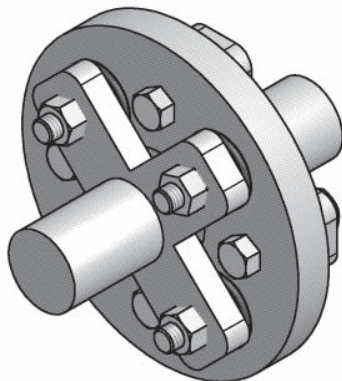
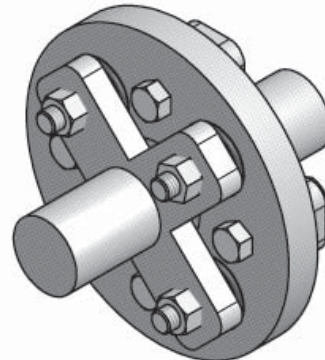

Figure 2 – Series Arrangement



Dynaflex Bushing-Type Couplings

Table 1 – Parallel Arrangement Selection

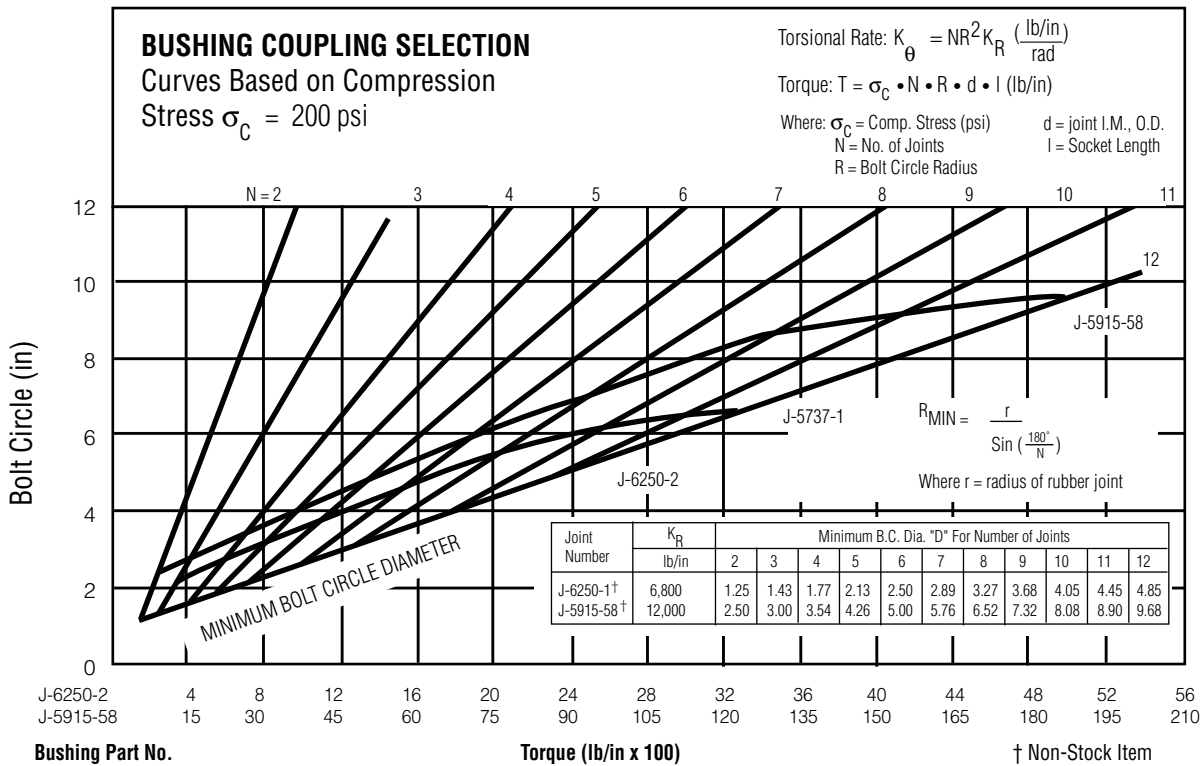
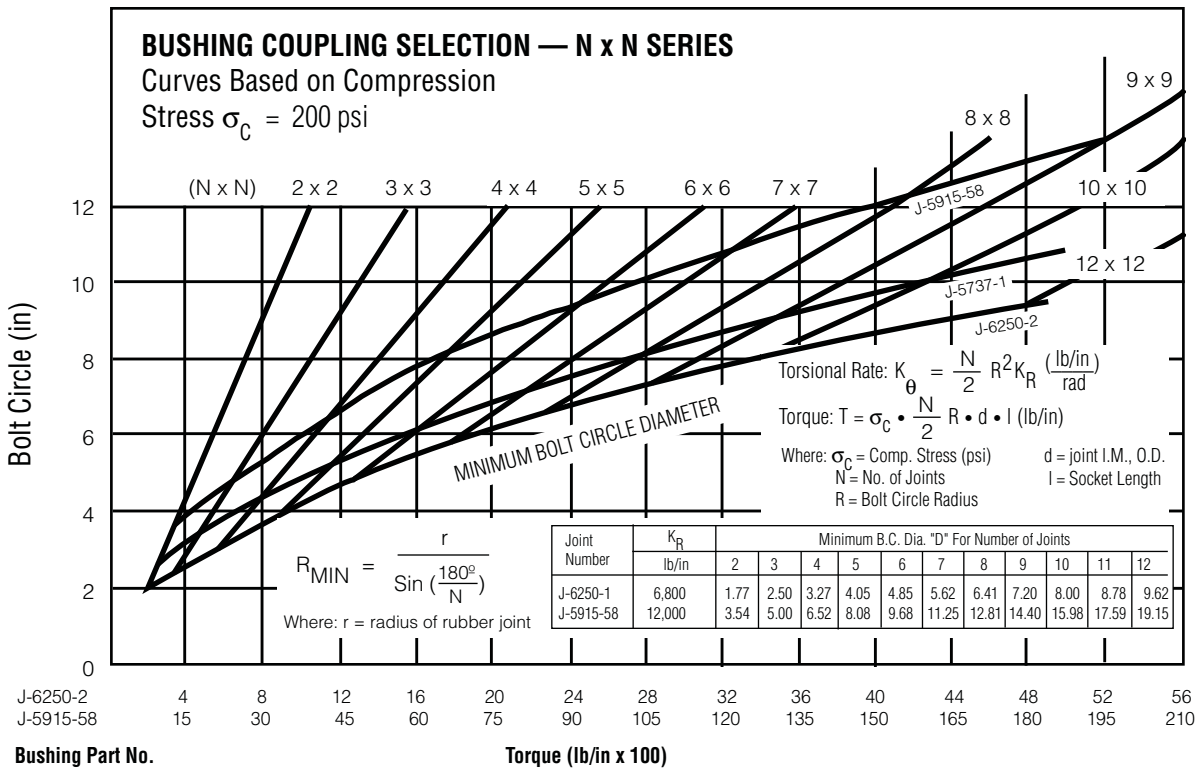

Table 2 – Series Arrangement Selection



A part's listing in this catalog does not guarantee its availability.

To download/print the most current catalog, go to www.lordfulfillment.com/upload/PC7000.pdf.

Figure 3 – Joint Dimensions - J-6250-2

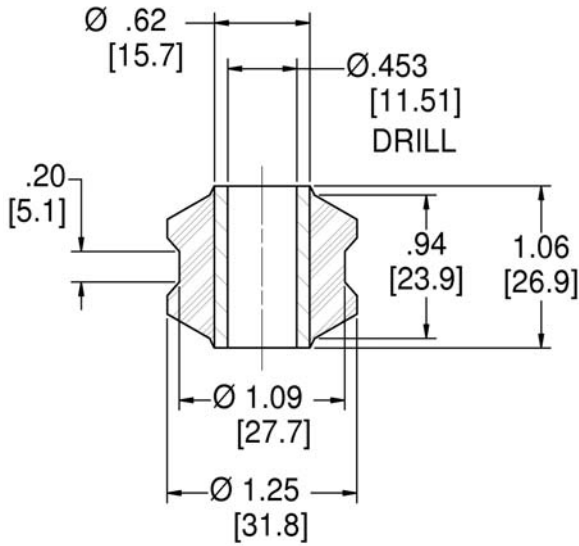

Figure 4 – Joint Dimensions - J-5915-58

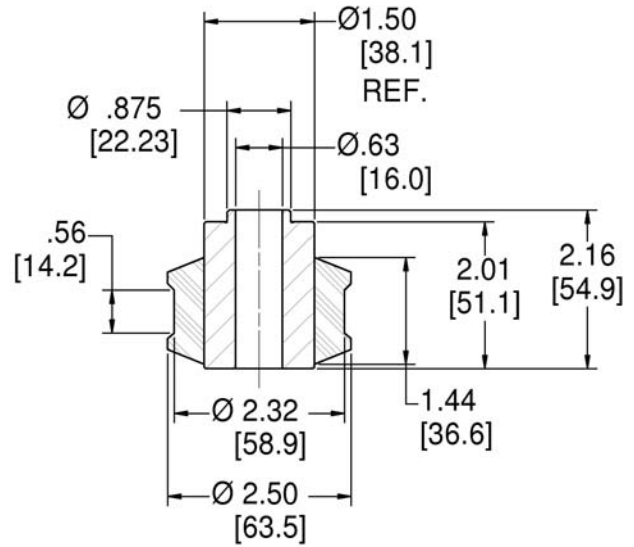
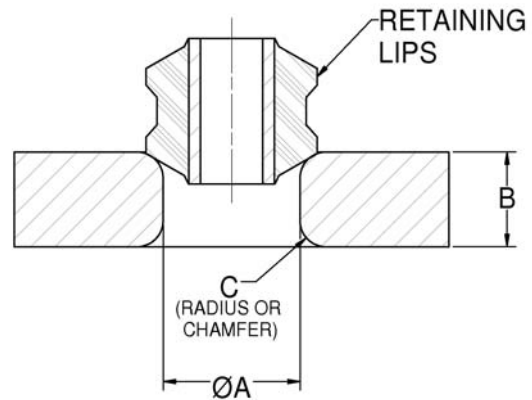

Table 3 – Typical Socket Dimensions

Part Number	A Socket Dia.		B		C			
					Radius		Chamfer x 45°	
	in	mm	in	mm	in	mm	in	mm
J-6250-2	1.00	25.4	0.69	17.5	0.19	4.8	0.13	3.3
J-5915-58	2.19	55.6	1.06	26.9	0.25	6.4	0.19	4.8

LORD does not supply hubs. Rubber elements only.

Figure 5 – Socket Dimensions



Installation Instructions: Use P-80 lube or equivalent mixed to manufacturer’s specifications. Immerse rubber bushing in P-80 solution, making sure entire bushing is wet. Insert bushing into socket by pressing with adequate force to seat the bushing properly between the retaining lips. Appearance of top and bottom should be uniform after assembly.

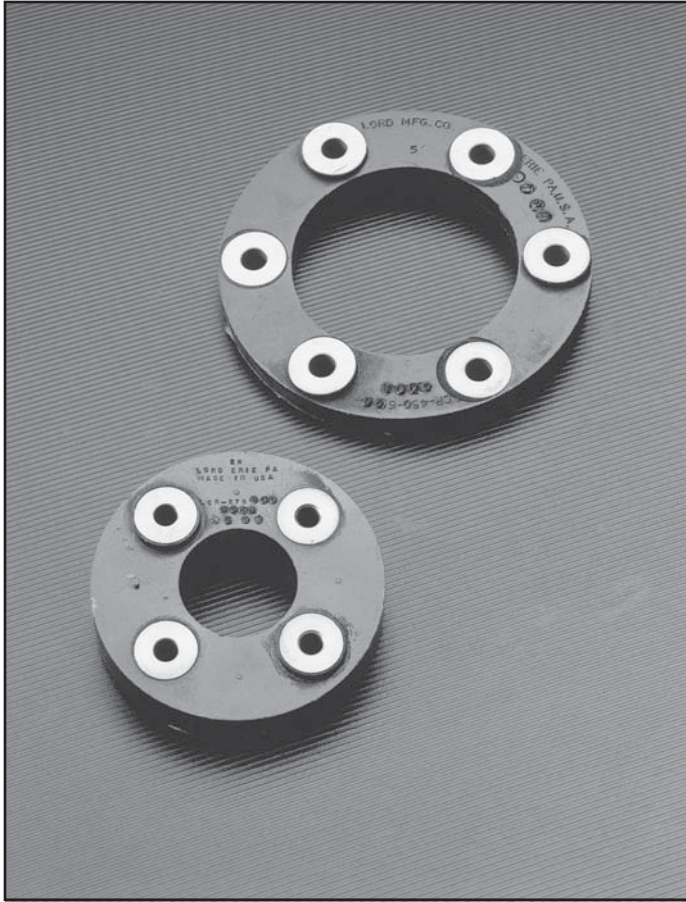

Dynaflex® LCR Series Couplings

Rated: 4 to 135 hp at 2000 rpm

LORD Dynaflex LCR Series Couplings are ring-type couplings developed to overcome numerous torsional problems associated with vehicular and industrial drive-line systems. These easily installed couplings reduce noise transmission and increase bearing and driveline life through greater misalignment accommodation, isolation of low frequency disturbances, and isolation of torsional shock.

These highly flexible elastomeric couplings for accessory drives are also designed to eliminate lubrication and maintenance.

Features and Benefits

- Misalignment accommodation – elastomeric flexibility allows for large angular misalignment. For permissible misalignments, including axial and radial, Refer to Table 1.
- Vibration isolation – low torsional spring rate is achieved with the elastomeric ring-type coupling using rubber in compression. This allows for low system natural frequencies and isolation of first mode driveline disturbances in most driveline systems.
- Shock protection – isolates torsional shock, prevents backlash and protects system components, including bearings, from fatigue failure.
- Long service life – Dynaflex LCR Series Couplings have proven themselves under demanding service conditions.
- Maintenance-free – elastomer flexibility accommodates all motion without wear, eliminates the need for lubrication.
- Noise reduction – no metal-to-metal contact; elastomer attenuates structure-borne noise and isolates vibration from components that would act as noise generators.
- Systems Engineering – LORD has in-house computer capabilities for multi-torsional analysis to assist in proper coupling selection.

Typical Applications

Dynaflex LCR Series Couplings are useful for a wide range of rotary drive applications, from lawn and garden tractors to large construction equipment, including U-joint replacement. Typical applications include:

Typical End Product	Application
Farm Tractor	Trouble-Free Hydraulic Pump Devices
Lawn & Garden Tractors	Maintenance-Free Main Drive Couplings
Dynamometer	Protects Driveline from Failure
Snowmobile	Reliable Main Drive Coupling
Vibratory Rollers	Absorbs High Torsional Shock Loads in Eccentric Drive Units
On- & Off-Highway	Isolates and Protects Vehicles Auxiliary Driveline Systems
Industrial Machinery	Provides Inexpensive Coupling for Maximum Angular Misalignment and Vibration Control
Agriculture Equipment	Replaces Conventional Universal Joints and Provides Torsional Flexibility

Dynaflex LCR Series Couplings were designed and developed by LORD and have been in service since the early 1960s. The basic concept was intended for specific applications requiring low-cost, flexible couplings to accommodate all forms of misalignment and provide torsional resilience.

The coupling design incorporates metal inserts bonded in an elastomeric ring, which loads the flexing element in compression to transmit torque. Misalignment motion is accommodated by deflecting the elastomer in shear, which allows extreme misalignment without high reaction forces.

They are ideally suited for light-duty elastomeric universal joints, particularly where noise reduction or shock attenuation is required.

Absence of metal-to-metal contact through the coupling eliminates the need for lubrication and maintenance, while also reducing noise transmissions. Installation is accomplished by insertion between simple parallel flanges. This lightweight coupling element can be arranged in a single or double series configuration to match specific torsional stiffness and misalignment requirements.

Static Load Deflection Characteristics of LCR-300-600-046A Reference Curve

Ring-type couplings isolate torsional vibration and reduce the harmful effects of torsion shock. Torsional resilience is one important characteristic. Figure 1 shows the torsional spring rate.

Accommodating axial misalignment along the axis of shafts without high reaction forces is a unique feature of ring couplings. Figure 2 shows this load deflection relationship.

Ring-type couplings accommodate parallel misalignment with relatively low radial reaction forces imposed on driving and driven equipment. Figure 3 shows typical radial load deflection curves. Load deflection characteristics for other LCR couplings are available upon request.

Figure 1 – Typical Load/Deflection Curves

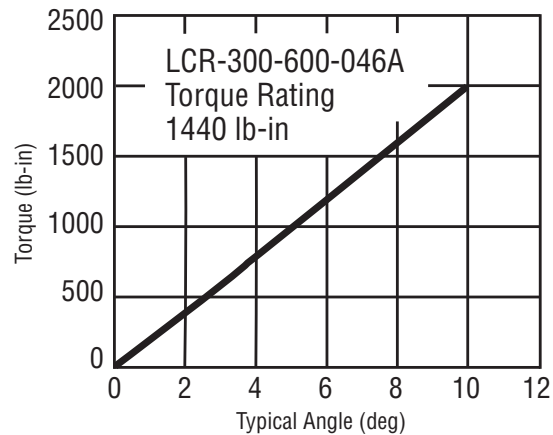

Figure 2 – Axial Load Deflection Curves

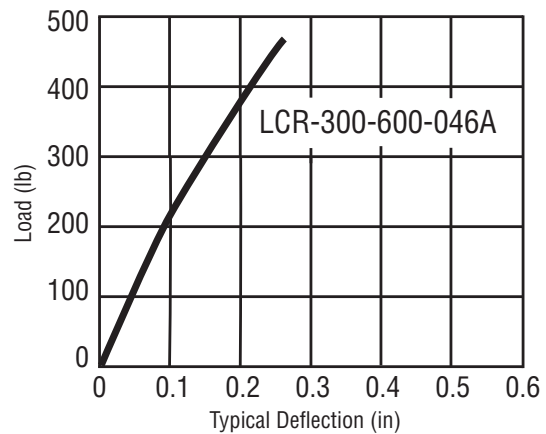
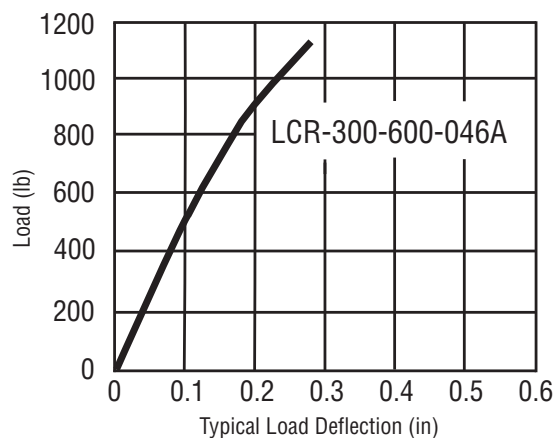

Figure 3 – Typical Radial Load Deflection Curves



Specifications

Materials: The elastomer used in Dynaflex LCR Series Couplings is high-quality natural rubber, which meets LORD specifications (available upon request) and exceeds SAE standards. Natural rubber is used because of its excellent physical properties such as tensile strength, tear and abrasion resistance, fatigue resistance and low temperature characteristics. Other elastomers are available to meet special applications needs. The elastomer-to-metal bonds are even stronger than the elastomers.

Dynaflex LCR Series Couplings listed on the following pages have aluminum alloy inserts. Many other insert configurations are possible to meet attachment requirements.

Environmental: Ring-type couplings will perform satisfactorily when exposed to the normal fluid, temperature and other environmental conditions found in drive-line systems. Special oil-resistant elastomers can be provided where total or partial oil immersion is necessary. For operation in ambient temperatures exceeding 170°F (77°C), consult LORD Engineering.

Misalignment: Misalignment capability applies for speeds up to 3500 rpm. Operation up to 7000 rpm is permitted with reduced misalignment (consult LORD Engineering).

Note: For speeds above 4000 rpm, shielding is required and/or balancing of assembly may be required.

Installation: Normal installation involves simple through bolt attachment to flanges. For flywheel attachment applications, metal inserts can be tapped/counter-bored to permit easy installation.

Remote Driven Units: Multiple U-joint shafts (especially longer shafts) and the speed at which the shaft rotates (especially higher rpm's) can create complex stability problems. To assure satisfactory coupling performance, all design layouts for remote mounted driven units should be reviewed by LORD Engineering. LORD analytical capability is only one part of the engineering service available on all coupling applications.

LCR ring-type couplings can be selected based on horsepower or maximum torque requirements. The data listed on the next page provides the necessary information to select a coupling and design it into your system.

New equipment designs and retrofits involving reciprocating engine drives and unusual driveline arrangements should be analyzed to avoid potential vibration and misalignment problems. Contact LORD Engineering for assistance.

Dynaflex LCR Series Couplings

Table 1 – Specifications and Dimensions

Part Number	Rated Performance Characteristics																				
	Torque Rating ①		Per 100 rpm		Capacity						Static Torsional Rate - K_{θ}		Axial Rate - K_A		Radial Rate - K_R		Permissible Misalignments				
	lb-in	N-m	hp	kW	1750 rpm		2000 rpm		3600 rpm		lb-in/rad	N-m/rad	lb/in	N/mm	lb/in	N/mm	Angular	Axial		Parallel	
					hp	kW	hp	kW	hp	kW								in	mm	in	mm
LCR-275-400-004A	125	14	0.20	0.15	3.5	2.6	4.0	3.0	7.1	5.3	420	47	150	26	375	66	±5°	±1/8	3.18	±1/16	1.59
LCR-275-400-009A	290	33	0.46	0.34	8.1	6.0	9.2	6.9	16.6	12.4	530	60	350	60	850	149	±4°	±3/32	2.38	±1/16	1.59
LCR-275-400-017A	550	62	0.87	0.65	15.3	11.4	17.5	13.0	31.4	23.4	1600	181	950	166	1300	228	±3°	±3/64	1.19	±1/32	0.79
LCR-300-600-046A	1440	163	2.28	1.70	40.0	29.8	45.7	34.1	82.3	61.3	18000	2034	2300	404	4500	790	±2°	±1/16	1.59	±1/32	0.79
LCR-400-800-060A	1900	215	3.01	2.24	52.8	39.3	60.3	45.0	108.5	80.9	24000	2712	1450	254	3000	525	±2°	±1/16	1.59	±1/64	0.40
LCR-400-800-115A	3600	407	5.71	4.26	100.0	74.5	114.2	85.2	205.6	153.3	46000	5197	3600	630	6400	1121	±2°	±1/16	1.59	±1/64	0.40
LCR-400-800-135A	4200	475	6.66	4.97	116.6	87.0	133.3	99.4	239.9	178.9	63000	7118	4200	736	9000	1576	±1-1/2°	±1/16	1.59	±1/64	0.40
LCR-450-600-011A	350	40	0.56	0.42	9.6	7.1	11.1	8.3	20.0	14.9	3100	350	1000	175	420	74	±5°	±1/8	3.18	±1/16	1.59

① Torque ratings as listed are maximum steady torques per application requirements. For general applications, dynamic torques of ±35 percent of the coupling rate torques can be applied to the listed torque ratings. Shock torques (e.g., start-up torque, etc.) of up to 200 percent rated torque are generally acceptable.

Torque Requirements:

$$\text{Torque (lb-in)} = \frac{63025 \times \text{hp}}{\text{rpm}}$$

Table 2 – Specifications and Dimensions

Part Number	Physical Characteristics (Nominal)*																				
	Weight		Inertia ②		No. of Inserts	A		B		C		D		E		F		G		H	
	lb-Mass	kg	lb-in-sec ²	kg-mm ²		B.C. Dia.		Hole Dia.		Coupling I.D.		Coupling I.D.		Length		Insert Dia.		Length		Length	
					in	mm	in	mm	in	mm	in	mm	in	mm	in	mm	in	mm	in	mm	in
LCR-275-400-004A	0.52	0.236	0.0020	226.0	4	2.75	69.85	0.32	8.13	4.00	101.60	1.62	41.15	1.00	25.40	0.91	23.11	0.12	3.18	0.75	19.05
LCR-275-400-009A	0.52	0.236	0.0020	226.0	4	2.75	69.85	0.32	8.13	4.00	101.60	1.62	41.15	1.00	25.40	0.91	23.11	0.12	3.18	0.75	19.05
LCR-275-400-017A	1.00	0.454	0.0038	430.0	4	2.75	69.85	0.32	8.13	4.00	101.60	1.62	41.15	1.75	44.45	0.91	23.11	0.12	3.18	1.50	38.10
LCR-300-600-046A	0.91	0.413	0.0041	463.0	6	3.00	76.20	0.39	9.91	4.06	103.12	1.88	47.75	1.53	38.86	1.00	25.40	0.12	3.18	1.28	32.50
LCR-400-800-060A	1.25	0.567	0.0072	814.0	8	4.00	101.60	0.51	12.95	5.21	132.33	2.74	69.60	1.50	38.10	1.00	25.40	0.12	3.18	1.25	31.75
LCR-400-800-115A	1.25	0.567	0.0072	814.0	8	4.00	101.60	0.51	12.95	5.21	132.33	2.74	69.60	1.50	38.10	1.00	25.40	0.12	3.18	1.25	31.75
LCR-400-800-135A	1.40	0.635	0.0099	111.9	8	4.00	101.60	0.51	12.95	5.21	132.33	2.74	69.60	2.00	50.80	1.00	25.40	0.12	3.18	1.75	44.45
LCR-450-600-011A	0.78	0.354	0.0032	362.0	6	4.50	114.30	0.41	10.30	5.56	141.22	3.40	86.36	0.68	17.27	1.00	25.40	0.12	3.18	0.43	10.92

* See detail drawings by part number for tolerances.

LORD does not supply hubs. LORD supplies ring elements only.

② Does not include bolts or flanges.

Figure 4 – Part Dimensions

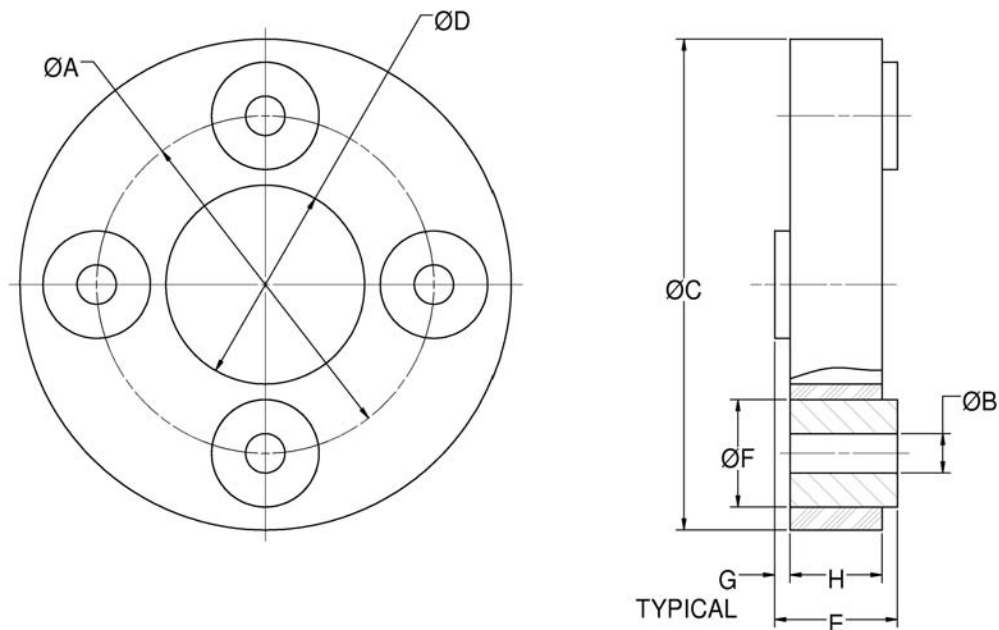
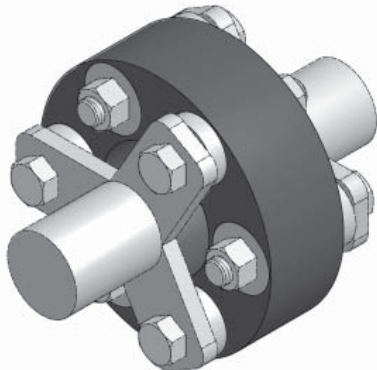
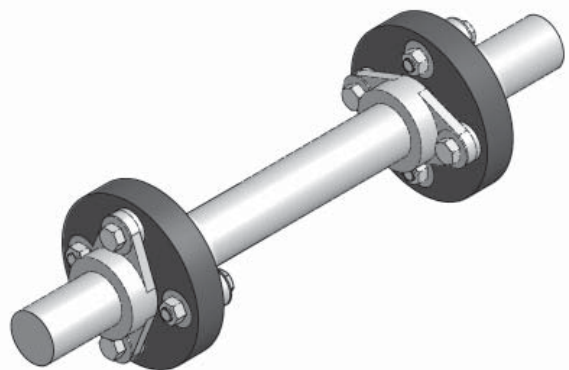

Figure 5 – Single Coupling Arrangement



Single coupling arrangement consists of two shafts jointed by a single coupling for maximum economy.

Figure 6 – Double Coupling Arrangement



Double coupling/series arrangement uses two couplings separated by a floating shaft. This provides same torque capacity as single hub arrangement, with twice the permissible angular misalignment and half the torsional stiffness. Superior to single coupling for control of torsional vibration.

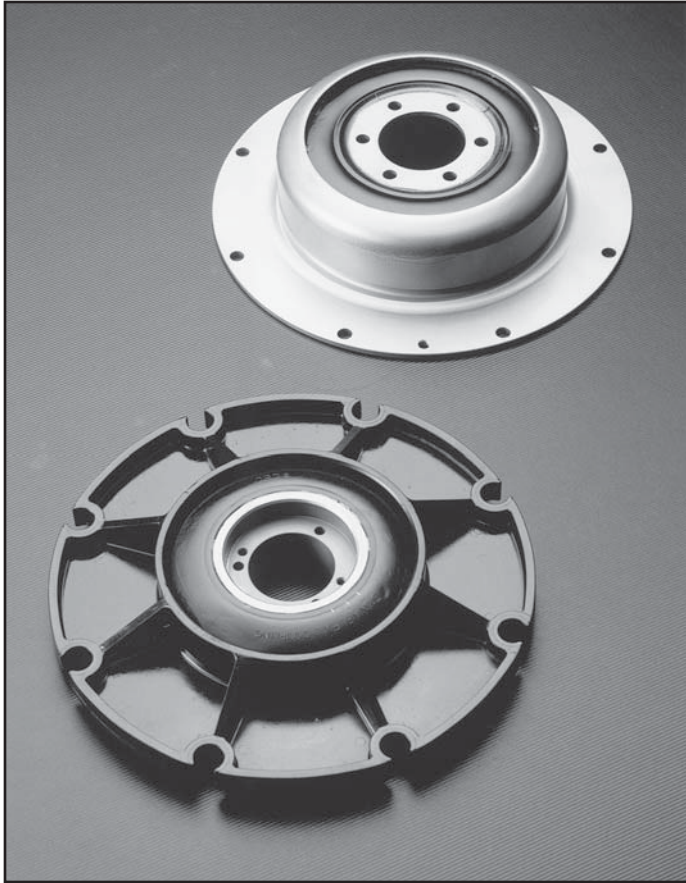

Dynaflex® LCD Series Couplings

Rated: 75 to 2000 hp at 2000 rpm

LORD Dynaflex LCD Series Couplings have been developed to overcome numerous torsional problems associated with vehicular and industrial driveline systems. These couplings increase equipment life by protecting against torsional vibration, shock and misalignment.

Typical application attachments include:

- Flywheel to shaft
- Flywheel to hub (splined)
- Shaft to shaft
- Floating shaft

Features and Benefits

- Protection from torsional shock loads
- Design flexibility
- Safe for occasional severe overloads
- Vibration isolation – extremely low torsional spring rate is achieved with the Dynaflex LCD Series Coupling, using elastomer in shear. This allows for low system natural frequencies and isolation of first mode driveline disturbances.
- Damping at resonance – the elastomer used in Dynaflex LCD Series Couplings effectively reduces vibration at resonance.
- Shock protection – torsional shock loads are attenuated by large shear deflection of the elastomer. In the case of severe overloads, equipment damage is prevented by slippage between the elastomer and the outer housing.
- Misalignment accommodation – elastomer flexibility allows for angular, parallel and axial misalignment.
- Long service life – Dynaflex LCD Series Couplings have proven themselves under demanding and rugged service conditions.
- Maintenance-free – elastomer flexibility accommodates all motion without wear, eliminates the need for lubrication.
- Noise reduction – no metal-to-metal contact; elastomer attenuates structure-borne noise and isolates vibration from components that would act as noise generators.
- Attachment – fits many standard SAE flywheels.
- Design flexibility – standard rubber molds are used to produce each different size coupling shown in this catalog. Often it is necessary to change metal components for custom applications. This is common.
- Systems Engineering – LORD has in-house computer capabilities for multi-mass torsional analysis to assist in proper coupling selection.

Standardization of Proven Concept

Using the experience gained in designing and producing special Dynaflex couplings, LORD has developed a new standard product line of heavy-duty Dynaflex couplings. These couplings have a specially designed elastomeric element bonded to a metal inner member which is then preloaded and friction-fit into an outer member.

This unique concept provides low torsional spring rates which effectively isolate critical vibratory disturbances in driveline and accessory systems, thus prolonging equipment life. Misalignment and torsional shock loads are absorbed by shear deflection in the elastomeric element.

The ability of the coupling to slip at the outer member with short duration shock overloads protects the driveline and accessory components from premature failure. The Dynaflex LCD Series Coupling has been particularly successful for diesel driven applications.

Dynaflex LCD Series Couplings are available in 75 to 2000 hp ratings at a nominal 2000 rpm. Each size is also available in two stiffness values. These are referred to as the A and C stiffness values. The C stiffness parts are normally stocked.

Load Deflection Data

Figures 1 through 3 illustrate the torque or load versus deflection characteristics for the -A and -C stiffnesses of the LCD-0400 size couplings. The general characteristics of these curves are typical for all Dynaflex LCD Series Couplings.

Figure 1 shows the linearity of the coupling spring rate at (and well above) the rated capacity of 12,500 lb-in torque. The curves also demonstrate the unique overload slip characteristic at about 60,000 lb-in torque. It should be noted, however, that the overload protection results from slipping of the coupling. This slipping generates heat, and therefore continuous running at overload could be injurious to the coupling.

Figures 2 and 3 illustrate the flexibility of Dynaflex LCD Series Couplings to accommodate axial and radial misalignment. The -A variation is made in a softer elastomer to produce a lower torsional spring rate and therefore had the lower axial and radial spring rates. All spring rates are ideally linear over the normal operating range of deflection.

Figure 1 – Torsional Load/Deflection Curves

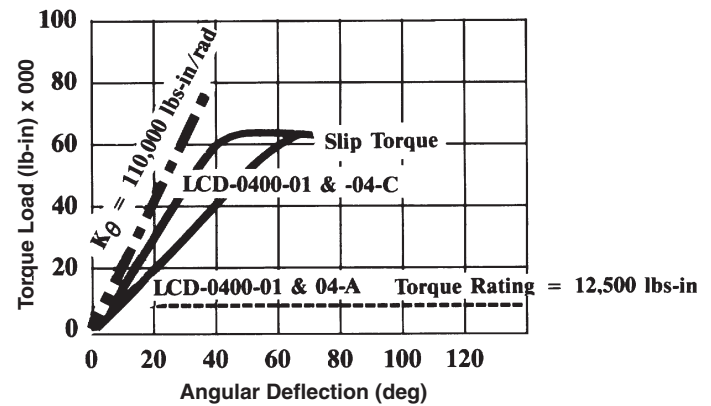

Figure 2 – Axial Load Deflection Curves

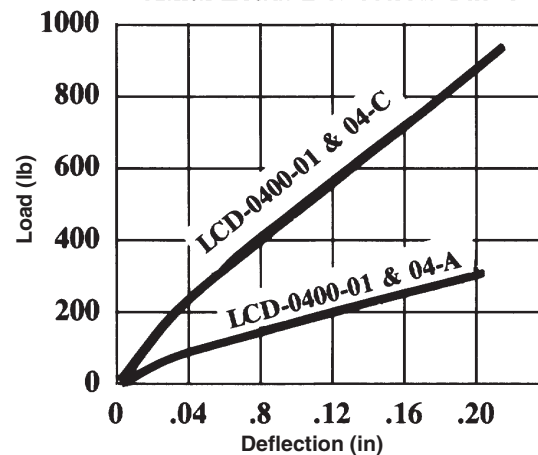
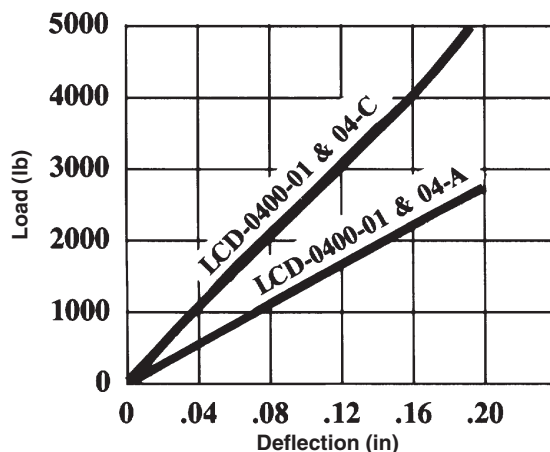

Figure 3 – Radial Load Deflection Curves



Dynamic Torsional Stiffness, K_{θ}

The dynamic torsional stiffness is higher than the static stiffness at room temperature. When the LCD Series Couplings are attached to diesel engine flywheels, the elastomer gets warm. At an operating temperature in the 170° to 200°F range, the dynamic stiffness is nearly the same as the static stiffness at room temperature. The stiffness values shown in the performance characteristics chart are for computer modelling and in other types of torsional analysis work.

Static Load Deflection Characteristics of LCD-0400-01-A & -C and LCD-0400-04-A & -C

Curves of other LCD parts show similar characteristics and are available upon request.

Typical Applications

Dynaflex LCD Series Couplings are useful for a wide range of rotary drive applications, from off-highway truck drivelines to auxiliary compressor drives on diesel locomotives. The soft torsional stiffness of these couplings makes them ideally suited for diesel applications with remotely mounted driven components. Typical applications include:

Typical End Product	Application
Mining Dump Truck	Increases Engine and Transmission Life
Diesel Locomotive	Eliminates Accessory Driveline Failure
Portable Air Compressor	Replaces Short-Lived Gear Coupling; Smooth Operation
4-Wheel Drive Farm Tractor	Reduces Noise and Extends Drive Train Life
Military Vehicle	Eliminates Accessory Shaft Breakage
Dynamometer	Prevents Driveline Failure
Mining Dump Truck	Prolongs U-Joint Life

In addition, Dynaflex LCD Series Couplings have been used in these types of applications:

- Main Drive
 - Engine – Generator Engine – Compressor
 - Engine – Transmission Engine – Pump
 - Electric Motor – Pump Electric Motor – Compressor
- Accessories
 - Starters Fans and Blowers
 - Alternators Power Take-Offs

Selection Guide

This selection guide can be used to determine the size and series coupling to suit your general requirements. Final selection of the specific coupling to satisfy all of the application requirements generally necessitates a system engineering analysis. These computerized analyses of torsional systems can be provided by LORD Corporation's Engineering Department.

Figure 4 – Typical Dynaflex LCD Coupling X Series - Type I Housing Couplings (0075, 0150, 0200, 0300) (With Tapered Inner Member)

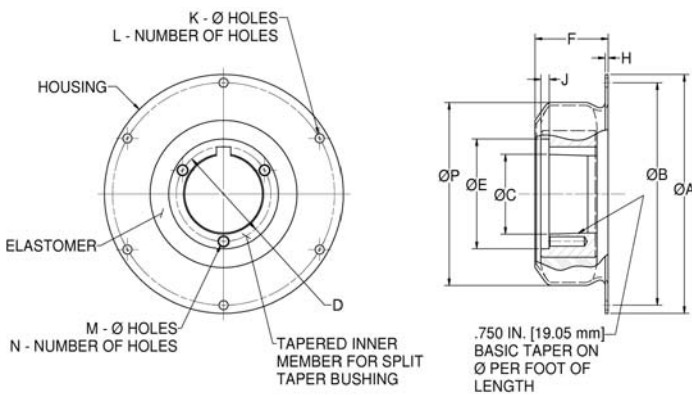

Note: The LCD-0075-13 design is the same as the "20 Series" except the outer member flange O.D. is very small.

Figure 5 – Typical Dynaflex LCD Coupling XX Series - Type II Housing Couplings (0075, 0150, 0200, 0300) (With Flanged Inner Member)

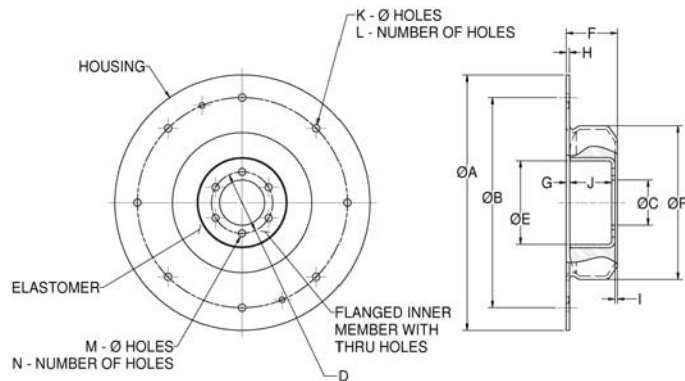
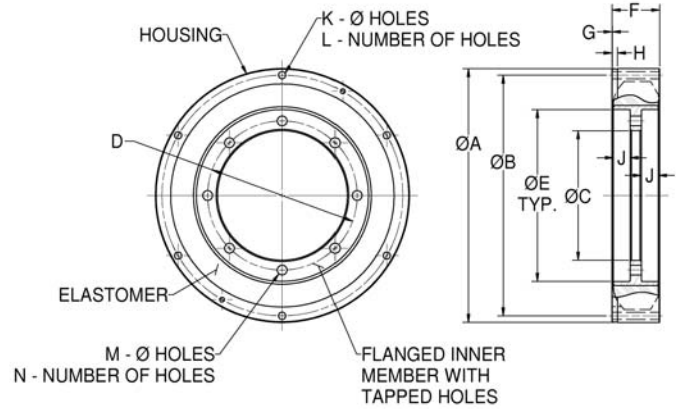

Figure 6 – Typical Dynaflex LCD Coupling 01 Series - Type III Housing Couplings (400 hp and above)



Note: 0400-04 has tapered inner member. 0600 and above do not have tapered inner member.

Figure 7 – Typical Dynaflex LCD Composite Outer Member (0075, With Tapered Inner Member)

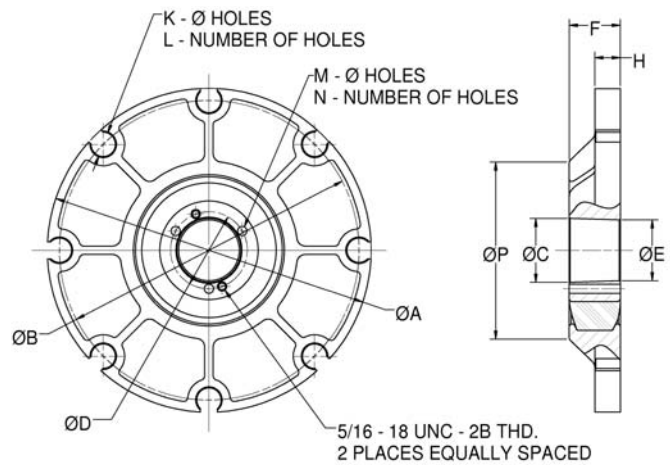

Table 1 – Split Tapered Bushings

Dynaflex LCD Series Coupling Part Number	P/N	Browning Bushing			
		Bore Range			
		Type 1 Dia.		Type 2 Dia.	
		in	mm	in	mm
LCD-0075	Q1	3/4 - 2-1/16	19.05 - 52.3	2-1/8 - 2-11/16	54.0 - 68.3
LCD-0150-XR	Q1	3/4 - 2-1/16	19.05 - 52.3	2-1/8 - 2-11/16	54.0 - 68.3
LCD-0200-XR	R1	1-1/8 - 2-13/16	28.16 - 71.4	2-7/8 - 3-3/4	73.0 - 95.2
LCD-0300-XR	R1	1-1/8 - 2-13/16	28.16 - 71.4	2-7/8 - 3-3/4	73.0 - 95.2
LCD-0400-XX	R1	1-1/8 - 2-13/16	28.16 - 71.4	2-7/8 - 3-3/4	73.0 - 95.2

Application Note: Sustained operation at torsional resonance can produce vibratory torques which might cause damage to the coupling and other driveline components. Please consult LORD Engineering for application review and approval.

Dynaflex LCD Series Couplings

Table 2 – Rated Performance Characteristics

Part Number*		Figure No.	Capacity per 100 rpm		Torque Rating T_N ①		Approximate Slip Torque ①		Torsional Rate K_θ ①		Axial Rate K_A		Radial Rate K_R	
Size	Variation		hp	kW	lb-in	N-m	lb-in	N-m	lb-in/rad	N-m/rad	lb/in	N/mm	lb/in	N/mm
LCD-0075	-XR-A -XXR-A	4 4	4.05	3.02	2,500	282	8,000	900	11,000	1,243	875	153	5,800	1,015
LCD-0075	-XR-C -XXR-C	4 4	4.05	3.02	2,500	282	8,000	900	21,000	2,373	2,100	368	10,000	1,750
LCD-0075 ② ③	-X-C	7	4.05	3.02	2,500	282	8,000	900	21,000	2,373	2,100	368	10,000	1,750
LCD-0150	-XR-A -XXR-A	4 5	8.09	6.04	5,000	565	20,000	2,260	22,000	2,486	1,750	306	11,500	2,012
LCD-0150	-XR-C -XXR-C	4 5	8.09	6.04	5,000	565	20,000	2,260	40,000	4,520	4,000	700	20,000	3,500
LCD-0200	-XR-A -XXR-A	4 5	11.11	8.29	7,000	791	28,000	3,164	35,000	3,955	2,600	455	14,000	2,450
LCD-0200	-XR-C -XXR-C	4 5	11.11	8.29	7,000	791	28,000	3,164	60,000	6,780	5,000	875	22,000	3,850
LCD-0300	-XR-A -XXR-A	4 5	15.87	11.84	10,000	1,130	40,000	4,520	50,000	5,650	3,500	612	11,500	2,012
LCD-0300	-XR-C -XXR-C	4 5	15.87	11.84	10,000	1,130	40,000	4,520	90,000	10,170	8,800	1,540	20,000	3,500
LCD-0400	-X-A -XX-A	6 6	19.83	14.79	12,500	1,412	60,000	6,780	60,000	6,780	1,750	306	12,500	2,188
LCD-0400	-X-C -XX-C	6 6	19.83	14.79	12,500	1,412	60,000	6,780	110,000	12,430	5,700	1,000	25,000	4,375
LCD-0600	-X-A -X-C	6 6	31.75	23.69	20,000	2,260	85,000	9,600	100,000	11,290	1,600	280	12,500	2,188
LCD-0800	-X-A -X-C	6 6	39.67	29.58	25,000	2,825	100,000	11,300	130,000 250,000	14,690 28,250	2,000 6,500	350 1,140	14,000 30,000	2,450 5,250
LCD-1000	-X-A -X-C	6 6	52.91	39.47	32,000	3,616	150,000	16,950	250,000 450,000	28,250 50,850	3,250 9,000	600 1,575	20,000 35,000	3,500 6,125
LCD-1500	-X-A -X-C	6 6	79.37	59.21	50,000	5,650	200,000	22,600	360,000 650,000	40,680 73,450	4,500 13,000	788 2,275	28,000 50,000	4,900 8,750
LCD-2000	-X-A -X-C	6 6	103.15	77.22	65,000	7,345	200,000	22,600	675,000 1,250,000	76,275 141,250	8,500 15,000	1,488 2,625	58,000 100,000	10,150 17,500

* Please consult LORD engineering for application review, approval and availability.

① Prolonged exposure to temperatures in the 0°F range and below produces a significantly reduced slip torque prior to driveline warm-up. This condition may result in the coupling's inability to transmit adequate drive torque for applications experiencing unusual cold temperature related parasitic loading.

② Blind assembly style with a notched periphery provides trouble-free, sliding assembly on flywheel drive pins when bolted access is not possible. Outer member is a composite material.

③ Use Wood's Sure-Grip® Bushing type SK or equivalent.

④ See detail drawings by part number for tolerances.

⑤ Pilot diameter tolerances are + .000/-.005 in for -A Series diameters and + .005/-.000 in for -C Series diameters.

⑥ Tapered.

⑦ Refer to SAE J620c for flywheel numbers 6-1/2, 10, 11-1/2, 16; to SAE J927a for numbers 60, 80, 100, 120, 160. See Tables 5 and 6.

Unless otherwise noted:
 .xx dim ± 0.030 in (± 0.762 mm)
 .xxx dim ± 0.015 in (± 0.381 mm)

Sure-Grip is a trademark of Altra Industrial Motion, Inc.

It is advisable to refer to drawing of coupling before ordering since it is not practical to show all details in this catalog.

Definition of Part Numbering System

Part Type	hp Rating	Attachment Variation	Torsional Stiffness Variation
LCD	-0400	-X -XX	-A

Torque Requirements:

$$\text{Torque (lb-in)} = \frac{63025 \times \text{hp}}{\text{rpm}}$$

Table 3 – Specifications and Dimensions

Part Number*		Physical Characteristics (Nominal) ④																	
		Weight Mass		Inertia				A ⑤		B		C		D ⑤		E		F	
				Inner Member		Outer Member		Pilot O.D.		B.C. Dia.		Dia.		Dia.		Dia.		Length	
Size	Variation	lb	kg	lb-in-sec ²	kg-m ²	lb-in-sec ²	kg-m ²	in	mm	in	mm	in	mm	in	mm	in	mm	in	mm
LCD-0075	-XR-A	6.5	2.95	0.04	0.004	0.21	0.024	8.500	215.90	7.875	200.03	2.875 ⑥	73.03 ⑥	3.375	85.73	No Counter Bore	No Counter Bore	2.62	66.55
	-XXR-A	8.3	3.76					12.375	314.33	11.625	295.28								
LCD-0075	-XR-C	6.5	2.95	0.04	0.004	0.21	0.024	8.500	215.90	7.875	200.03	2.875 ⑥	73.03 ⑥	3.375	85.73	No Counter Bore	No Counter Bore	2.62	66.55
	-XXR-C	8.3	3.87					12.375	314.33	11.625	295.28								
LCD-0075 ②	-X-C	6.3	2.87	0.04	0.004	0.07	0.007	10.340	262.58	9.625	244.48	2.813	71.45	3.313	84.14	2.688	68.28	2.00	50.8
LCD-0150	-XR-A	20	9.07	0.13	0.015	0.29	0.033	12.375	314.33	11.625	295.28	2.875	73.03	3.375	85.73	4.25	107.95	2.80	71.12
	-XXR-A	13.8	6.26					0.08	0.009	0.009	2.500	63.50	3.400	86.36	4.57	120.65			
LCD-0150	-XR-C	20	9.07	0.13	0.015	0.29	0.033	12.375	314.33	11.625	295.28	2.875 ⑥	73.03 ⑥	3.375	85.73	4.25	107.95	2.80	71.12
	-XXR-C	13.8	6.26					0.08	0.009	0.009	2.500	63.50	3.400	86.36	4.57	120.65			
LCD-0200	-XR-A	21	9.52	0.22	0.025	0.69	0.078	13.875	352.42	13.125	333.38	4.000 ⑥	101.60 ⑥	4.625	117.47	5.50	139.70	2.80	71.12
	-XXR-A	16	7.26					0.09	0.010	0.010	2.500	63.50	3.400	86.36	5.33	135.38			
LCD-0200	-XR-C	21	9.52	0.22	0.025	0.69	0.078	13.875	352.42	13.125	333.38	4.000 ⑥	101.60 ⑥	4.625	117.47	5.50	139.70	2.80	71.12
	-XXR-C	16	7.26					0.09	0.010	0.010	2.500	63.50	3.400	86.36	5.33	135.38			
LCD-0300	-XR-A	33	14.96	0.59	0.067	0.92	0.104	13.875	352.42	13.125	333.38	4.000 ⑥	101.60 ⑥	4.625	117.47	6.00	152.40	3.06	77.72
	-XXR-A	18	8.16					0.25	0.028	0.028	4.000	101.60	5.125	130.18	6.69	170.00			
LCD-0300	-XR-C	33	14.96	0.59	0.067	0.92	0.104	13.875	352.42	13.125	333.38	4.000 ⑥	101.60 ⑥	4.625	117.47	6.00	152.40	3.06	77.72
	-XXR-C	18	8.16					0.25	0.028	0.028	4.000	101.60	5.125	130.18	6.69	170.00			
LCD-0400	-X-A	45	20.41	0.57	0.065	2.83	0.320	13.875	352.42	13.125	333.38	6.000 ⑥	152.40 ⑥	7.000	177.80	8.00	203.20	2.75	69.85
	-XX-A	48	21.77					0.93	0.150	0.150	4.000	101.60	4.625	117.47	6.00	152.4			
LCD-0400	-X-C	45	20.41	0.57	0.065	2.83	0.320	13.875	352.42	13.125	333.38	6.000 ⑥	152.40 ⑥	7.000	177.80	8.00	203.20	2.75	69.85
	-XX-C	48	21.77					0.93	0.150	0.150	4.000	101.60	4.625	117.47	6.00	152.4			
LCD-0600	-X-A	62	28.11	1.12	0.127	5.23	0.591	15.500	393.70	14.625	371.47	6.000 ⑥	152.40 ⑥	7.000	177.80	8.00	203.20	3.00	76.20
LCD-0600	-X-C	62	28.11	1.12	0.127	5.23	0.591	15.500	393.70	14.625	371.47	6.000 ⑥	152.40 ⑥	7.000	177.80	8.00	203.20	3.00	76.20
LCD-0800	-X-A	81	36.60	1.25	0.141	8.21	0.928	17.000	431.80	16.250	412.75	7.500	190.50	8.500	215.90	9.50	241.30	3.50	88.90
LCD-0800	-X-C	81	36.60	1.25	0.141	8.21	0.928	17.000	431.80	16.250	412.75	7.500	190.50	8.500	215.90	9.50	241.30	3.50	88.90
LCD-1000	-X-A	105	47.62	3.51	0.397	14.57	1.647	19.000	482.60	18.125	460.37	8.825	224.16	10.125	257.18	11.52	292.61	4.00	101.60
LCD-1000	-X-C	105	47.62	3.51	0.397	14.57	1.647	19.000	482.60	18.125	460.37	8.825	224.16	10.125	257.18	11.52	292.61	4.00	101.60
LCD-1500	-X-A	160	72.58	6.23	0.704	32.50	3.673	22.500	622.22	21.375	542.93	10.000	254.00	11.500	292.10	13.25	336.55	4.25	107.95
LCD-1500	-X-C	160	72.58	6.23	0.704	32.50	3.673	22.500	622.22	21.375	542.93	10.000	254.00	11.500	292.10	13.25	336.55	4.25	107.95
LCD-2000	-X-A	160	72.58	7.40	0.836	31.48	3.557	22.500	622.22	21.375	542.93	11.500	292.19	13.250	336.55	15.25	387.35	4.25	107.95
LCD-2000	-X-C	160	72.58	7.40	0.836	31.48	3.557	22.500	622.22	21.375	542.93	11.500	292.19	13.250	336.55	15.25	387.35	4.25	107.95

* Please consult LORD engineering for application review, approval and availability.

① Prolonged exposure to temperatures in the 0°F range and below produces a significantly reduced slip torque prior to driveline warm-up. This condition may result in the coupling's inability to transmit adequate drive torque for applications experiencing unusual cold temperature related parasitic loading.

② Blind assembly style with a notched periphery provides trouble-free, sliding assembly on flywheel drive pins when bolted access is not possible. Outer member is a composite material.

③ Use Wood's Sure-Grip® Bushing type SK or equivalent.

④ See detail drawings by part number for tolerances.

⑤ Pilot diameter tolerances are + .000/ -.005 in for -A Series diameters and + .005/ -.000 in for -C Series diameters.

⑥ Tapered.

⑦ Refer to SAE J620c for flywheel numbers 6-1/2, 10, 11-1/2, 16; to SAE J927a for numbers 60, 80, 100, 120, 160. See Tables 5 and 6.

Unless otherwise noted:

.xx dim ± 0.030 in (± 0.762 mm)

.xxx dim ± 0.015 in (± 0.381 mm)

Sure-Grip is a trademark of Altra Industrial Motion, Inc.

It is advisable to refer to drawing of coupling before ordering since it is not practical to show all details in this catalog.

Definition of Part Numbering System

Part Type	hp Rating	Attachment Variation	Torsional Stiffness Variation
LCD	-0400	-X -XX	-A

Torque Requirements:

$$\text{Torque (lb-in)} = \frac{63025 \times \text{hp}}{\text{rpm}}$$

Table 4 – Specifications and Dimensions

Part Number*		Physical Characteristics (Nominal) ④															
		G Length		H Length		I Length		J Length		K Hole Dia.		L No. of Holes	M Hole Size in (mm)	N No. of Holes	Fits SAE ⑦ Flywheel No.	P Ref. Dia.	
Size	Variation	in	mm	in	mm	in	mm	in	mm	in	mm					in	mm
LCD-0075	-XR-A -XXR-A	0.375	9.53	0.125	3.18	0.25	6.35	No Counter Bore	No Counter Bore	0.321 0.406	8.15 10.31	6 8	3/8 - 16 UNC-2B	3	6-1/2 10	6.50	165.1
LCD-0075	-XR-C -XXR-C	0.375	9.53	0.125	3.18	0.25	6.35	No Counter Bore	No Counter Bore	0.321 0.406	8.15 10.31	6 8	3/8 - 16 UNC-2B	3	6-1/2 10	6.50	165.1
LCD-0075 ②	-X-C	-	-	0.75	19.1	-	-	-	-	0.710	18.03	6	0.330 (8.38)	3	8	6.80	172.7
LCD-0150	-XR-A -XXR-A	0.1875	4.76	0.1875	4.76	0.125	3.18	0.75 2.31	19.05 58.72	0.406	10.31	8	3/8-16 UNC-2B 0.394 (10.00)	3 6	10	8.50	215.9
LCD-0150	-XR-C -XXR-C	0.1875	4.76	0.1875	4.76	0.125	3.18	0.75 2.31	19.05 58.72	0.406	10.31	8	3/8-16 UNC-2B 0.394 (10.00)	3 6	10	8.50	215.9
LCD-0200	-XR-A -XXR-A	0.0625	1.59	0.1875	4.76	-	-	0.75 2.56	19.05 65.07	0.406	10.31	16	3/8-16 UNC-2B 0.394 (10.00)	3 6	11-1/2 OR 60/80/100	9.38	238.3
LCD-0200	-XR-C -XXR-C	0.0625	1.59	0.1875	4.76	-	-	0.75 2.56	19.05 65.07	0.406	10.31	16	3/8-16 UNC-2B 0.394 (10.00)	3 6	11-1/2 OR 60/80/100	9.38	238.3
LCD-0300	-XR-A -XXR-A	0.125	3.18	0.1875	4.76	0.25	6.35	0.75 2.56	19.05 65.07	0.406	10.31	16	3/8-16 UNC-2B 0.660 (16.76)	3 6	11-1/2 OR 60/80/100	11.38	289.1
LCD-0300	-XR-C -XXR-C	0.125	3.18	0.1875	4.76	0.25	6.35	0.75 2.56	19.05 65.07	0.406	10.31	16	3/8-16 UNC-2B 0.660 (16.76)	3 6	11-1/2 OR 60/80/100	11.38	289.1
LCD-0400	-X-A -XX-A	0.125	3.18	0.50	12.70	-	-	0.88 0.75	22.23 19.05	0.406	10.31	12	1/2-13 UNC-2B 3/8-16 UNC-2B	6 3	60/80/100	-	-
LCD-0400	-X-C -XX-C	0.125	3.18	0.50	12.70	-	-	0.88 0.75	22.23 19.05	0.406	10.31	12	1/2-13 UNC-2B 3/8-16 UNC-2B	6 3	60/80/100	-	-
LCD-0600	-X-A -X-C	-	-	0.50	12.70	-	-	1.00	25.40	0.406	10.31	12	1/2-13 UNC-2B	6	120	-	-
LCD-0800	-X-A -X-C	-	-	0.50	12.70	-	-	1.00	25.40	0.406	10.31	8	1/2-13 UNC-2B	8	-	-	-
LCD-1000	-X-A -X-C	0.125	3.18	0.25	6.35	-	-	1.00	25.40	0.406	10.31	12	5/8-11 UNC-2B	8	14 or 140 with Adapter	-	-
LCD-1500	-X-A -X-C	0.125	3.18	0.50	12.70	0.50	12.70	1.50	38.10	0.644	16.36	6	5/8-11 UNC-2B	8	18 or 180	-	-
LCD-2000	-X-A -X-C	0.125	3.18	0.50	12.70	0.50	12.70	1.50	38.10	0.644	16.36	6	3/4-10 UNC-2B	8	18 or 180	-	-

* Please consult LORD engineering for application review, approval and availability.

① Prolonged exposure to temperatures in the 0°F range and below produces a significantly reduced slip torque prior to driveline warm-up. This condition may result in the coupling's inability to transmit adequate drive torque for applications experiencing unusual cold temperature related parasitic loading.

② Blind assembly style with a notched periphery provides trouble-free, sliding assembly on flywheel drive pins when bolted access is not possible. Outer member is a composite material.

③ Use Wood's Sure-Grip® Bushing type SK or equivalent.

④ See detail drawings by part number for tolerances.

⑤ Pilot diameter tolerances are +.000/-.005 in for -A Series diameters and +.005/-.000 in for -C Series diameters.

⑥ Tapered.

⑦ Refer to SAE J620c for flywheel numbers 6-1/2, 10, 11-1/2, 16; to SAE J927a for numbers 60, 80, 100, 120, 160. See Tables 5 and 6.

Unless otherwise noted:

.xx dim ± 0.030 in (± 0.762 mm)

.xxx dim ± 0.015 in (± 0.381 mm)

Sure-Grip is a trademark of Altra Industrial Motion, Inc.

It is advisable to refer to drawing of coupling before ordering since it is not practical to show all details in this catalog.

Definition of Part Numbering System

Part Type	hp Rating	Attachment Variation	Torsional Stiffness Variation
LCD	-0400	-X -XX	-A

Torque Requirements:

$$\text{Torque (lb-in)} = \frac{63025 \times \text{hp}}{\text{rpm}}$$

Dynaflex LCD Series Couplings Installation Guide

Specifications

Materials: The elastomer used in the Dynaflex LCD Series Coupling is a high-quality natural rubber which meets LORD specifications (available upon request) and exceeds SAE standards. Natural rubber is used because of its excellent physical properties, such as tensile strength, tear and abrasion resistance, fatigue resistance and low temperature characteristics. The elastomer-to-metal bonds are even stronger than the elastomers.

Standard LCD catalog parts are all made in two stiffnesses of natural rubber. The A elastomer is per LORD Spec MAP092, having a durometer of approximately 45. The C elastomer is LORD Spec MAP094, having a durometer of approximately 57. The metal parts for this series are of alloy steel or ductile iron.

Environmental: Extensive experience with similar parts indicates that heavy-duty Dynaflex couplings will perform satisfactorily when exposed to the normal fluid, temperature and other environmental conditions found in driveline systems. For operation in ambient temperatures exceeding 170°F (77°C), consult LORD Corporation. Dynaflex LCD Series Couplings are often recommended for use in applications where the temperature is above 170°F (77°C). Temperatures above 200°F (93°C) could present problems. Customers should know what the ambient operating temperature is and whether additional air circulation can be provided. Consultation with LORD Corporation engineers is necessary if the ambient temperature is above 170°F (77°C).

Misalignment: Misalignment capability applies to speeds up to 2500 rpm. Operation up to 3500 rpm is permitted with reduced misalignment. (Consult LORD when a potential application requires special consideration).

At normal rated operating conditions, the Dynaflex LCD Series Couplings are designed to accommodate misalignment.

Angular: 1-1/2° maximum

Parallel: 1/64 inch

Axial: +1/16 inch dynamic
+1/8 inch static

Testing/Performance: Periodic load deflection tests are run to assure consistency of torsional spring rate and slip torque characteristics.

Damping Coefficient, C_D : The natural rubber elastomer used in LCD couplings offer hysteresis damping which dissipates energy at resonance.

The “damping coefficient” is a function of many variables. Among them are dynamic strain, frequency, elastomer type and stiffness, temperature and torque loading. Damping coefficients for this series have been determined and can be provided for torsional analysis work by contacting LORD.

Installation

For engine applications, the outer member is usually bolted directly to the flywheel; for other applications, to a suitable adaptor. The inner member normally attaches to the driven shaft. The smaller LCD couplings generally have a tapered bore, which accommodates a standard split tapered bushing which grips the drive shaft. (Refer to Table 1 - Split Tapered Bushings). This configuration provides easy installation.

Figures 15 and 16 on the next page show typical installations involving universal joints.

Figure 8

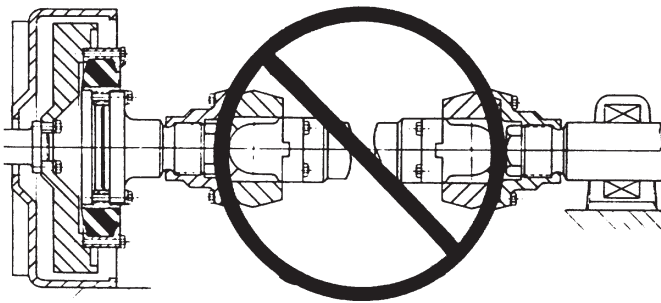

This arrangement must not be used. Suitable bearing supports are required to react cardan-induced cocking loads. Consult LORD Engineering for application review.

Figure 9 – Flywheel Drawing for Tables 5 and 6

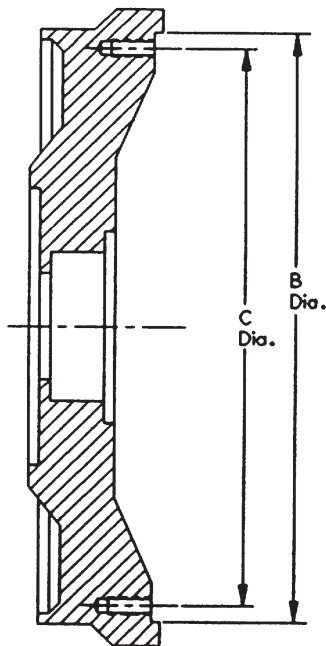

Table 5 – Flywheels for Engine Mounted Torque Converters - SAE J927 Nov 88

Converter Flywheel No.	B		C		Tapped Holes	
	in	mm	in	mm	No.	Size
20	9.50	241.30	8.750	222.25	12	5/16-18
40	10.375	263.52	9.625	244.48	12	5/16-18
60	13.875	352.42	13.125	333.38	12	3/8-16
80	13.875	352.42	13.125	333.38	12	3/8-16
100	13.875	352.42	13.125	333.38	12	3/8-16
120	15.500	393.70	14.625	371.48	12	3/8-16
140	18.375	466.72	17.250	438.15	12	1/2-13
160	20.375	517.52	19.250	488.95	12	1/2-13
180	22.500	571.52	21.375	542.92	12	5/8-11
210	26.500	673.10	25.250	641.35	12	5/8-11
240	28.875	733.42	27.250	642.15	12	3/4-10

Table 6 – Flywheels for Industrial Engines with Industrial Power Take-Offs - SAE J620 Oct 88

Clutch Size	B		C		Tapped Holes	
	in	mm	in	mm	No.	Size
165 (6-1/2)	8.500	215.90	7.875	200.02	6	5/16-18
190 (7-1/2)	9.500	241.30	8.750	222.25	8	5/16-18
200 (8)	10.375	263.52	9.625	244.48	6	3/8-16
255 (10)	12.375	314.32	11.625	295.28	8	3/8-16
290 (11-1/2)	13.875	352.42	13.125	333.38	8	3/8-16
355 (14)	18.375	466.72	17.250	438.15	8	1/2-13
405 (16)	20.375	517.52	19.250	488.95	8	1/2-13
460 (18)	22.500	571.50	21.375	542.92	6	5/8-11
530 (21)	26.500	673.10	25.250	641.35	12	5/8-11
610 (24)	28.875	733.42	27.250	692.15	12	3/4-10

Typical Installations

Figure 10 – Engine Flywheel to Keyed Shaft - Direct

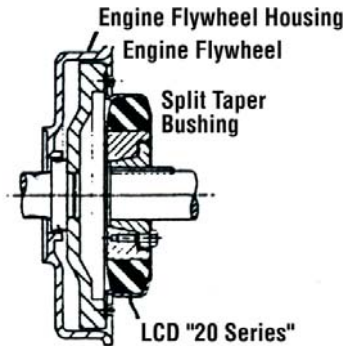

Figure 11 – Flywheel to Flanged Shaft - Direct (LCD -25 Series)

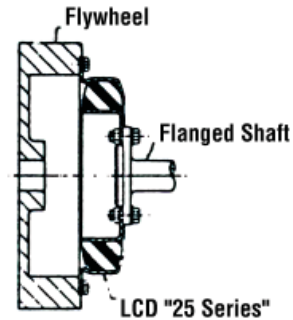

Figure 12 – Flywheel to Flanged Shaft - Direct (LCD -01 Series)

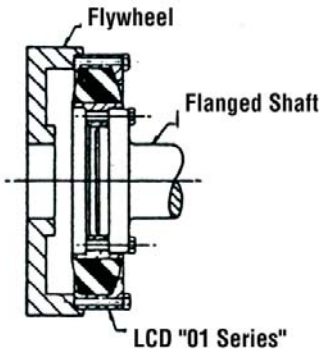

Figure 13 – Flywheel to Internally Splined Shaft - Free Floating Splined Connection

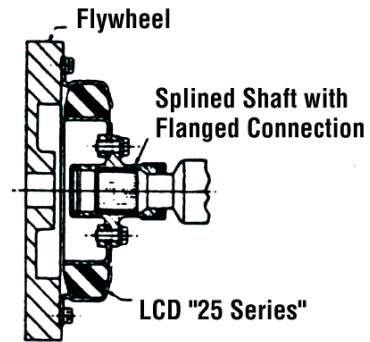

Figure 14 – Flywheel to Adapter to Coupling and Through an Internally Splined Connection

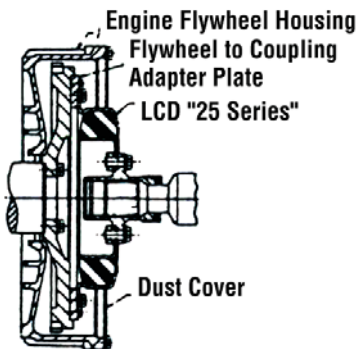

Figure 15 – Stationary Engine to Load by Use of a Pillow Block on a Common Frame - Permits Large Drive Angles

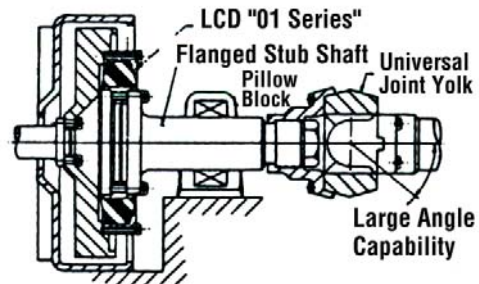

Figure 16 – Vehicle Engine with Large Angle Drive Requirements

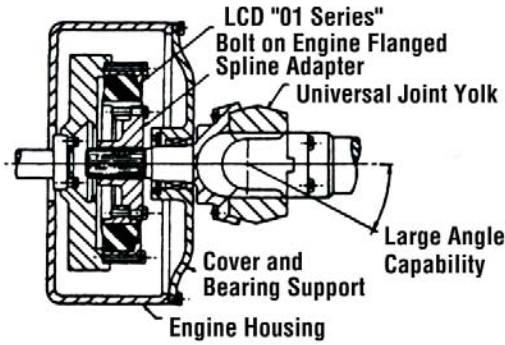

Figure 17 – Flywheel to Flanged Hub to Splined Shaft - Free Floating Splined Connection

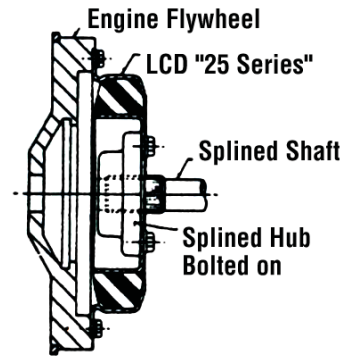

Figure 18 – Stationary Equipment Having a Tapered Shaft Connection

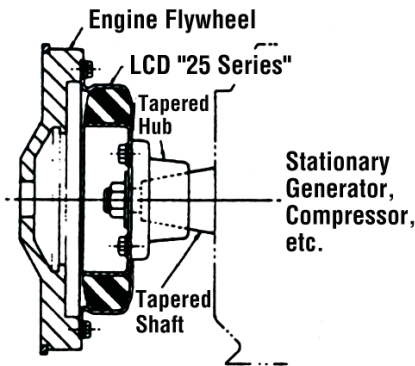

Figure 19 – Shaft to Shaft Arrangement Using Split Taper Bushings at Both Sides

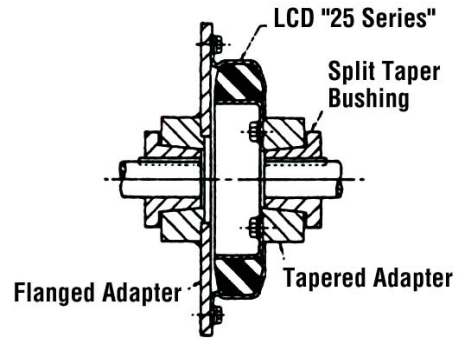

Figure 20 – Two Dynaflex LCD Couplings in Series for Increased Flexibility in All Directions

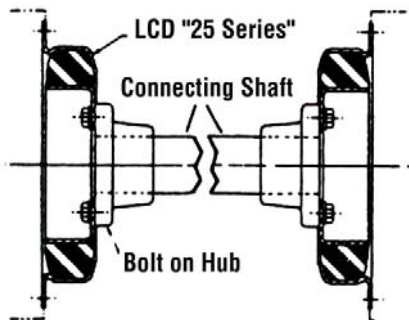
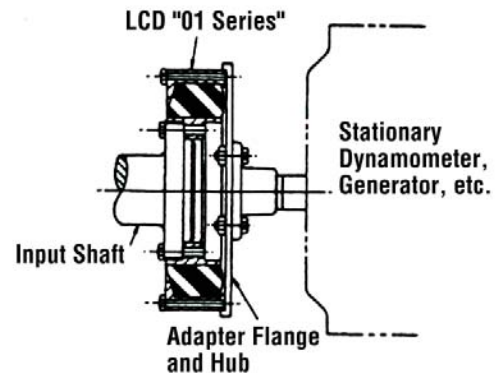

Figure 21 – Stationary Equipment Having Input Shaft Attached to Coupling Inner Member



Dynaflex LCD Series Couplings Torsional System Analysis Input Requirements

Dynaflex couplings offer unique advantages with the soft torsional spring rate that isolates torsional vibration, mitigates shock and reduces noise transmission. In order to benefit from these advantages, an analysis must be made of the application and a coupling selected which meets the specific requirements. The following checklist sets forth the information required to initiate the analysis:

Application Data

- What is the driving unit, driven unit? Include enough information to determine disturbing frequencies (e.g., type of engine, number of cylinders, number of cycles).
- What is the operating torque (normal, maximum)?
- What is the operating speed (range, at normal torque and at maximum torque)?
- What are the environmental conditions (temperature, oil type and amount of exposure, corrosive factors, other factors)?

Coupling Requirements

- What are the primary functions of the coupling (torsional vibration isolation, torsional shock mitigation, noise attenuation, shaft misalignment accommodation – angular, parallel, axial)?
- If known, what torsional spring rate should the coupling have?
- If the required torsional spring rate is not known, what are the rotational moments on inertia of the driving and driven masses?
- How much misalignment must the coupling accommodate (angular, parallel, axial)?
- How much, if any, axial thrust will be on the coupling?

Design Parameters

- What space is available for the coupling (maximum length, diameter)?
- What is the maximum weight the coupling can be, if weight is limited?
- What are the shaft diameters and method of attachment (keyway, spline, set screws, flange)?
- What special features are required? (Inner member design – hubs, flanges, splines, etc. Outer member design – pilot diameter bolt pattern, etc.)

Remote Driven Units

Multiple U-joint shafts (especially longer shafts) and the speed at which the shaft rotates (especially higher rpm's) can create complex stability problems. To assure satisfactory coupling performance, all design layouts for remote mounted driven units should be reviewed by LORD Engineering. LORD analytical capability is only one part of the engineering service available on all coupling applications.

What Else?

If your application is unique or unusual, include any information that you believe will have an effect on the coupling design or selection. If you have any questions as you prepare this data, call us. See following page for data form.

Reference Literature from Lord Corporation

Design Monograph 1107

Understanding Torsional Vibration

Data Required for LORD Coupling Recommendation

Toll Free Number (in United States and Canada): +1 877 ASK LORD (275 5673)

All Information in This Box is Required Data.

Date _____ LORD Recommended P/N _____

Company Name _____ Field Engineer _____

Address _____ Discussed With _____

_____ Title _____

General description of problem and equipment _____

Retrofit New System

APPLICATION

Driving Unit

- * Description _____
- * Model No. _____ * Manufacturer _____
- * 2-Stroke/Cycle 4-Stroke/Cycle
- * Rotational Inertia and Torsional Spring Rate Data (attach tabulated data)
- * Radial Support Needed: Yes No

Driven Unit

- * Description _____
- * Model No. _____ * Manufacturer _____
- * Rotational Inertia and Torsional Spring Rate Data (attach tabulated data)
- * Parasitic Torque required _____ lb-ft

SYSTEM DYNAMICS

- * Mass elastic schematic of entire system (please attach sketch)
- Test data (attach if available)
- Speeds of Driving Unit: Idle _____ RPM Normal _____ RPM Maximum _____ RPM
- % Time: @ Idle _____ @ Normal _____ @ Maximum _____
- Speed Ratio Driving to Driven Unit: _____ to _____
- * Torque: Normal _____ lb-ft Maximum _____ lb-ft (@ _____ RPM)
- Present Vibration: Peak-to-Peak Response Maximum _____ lb-ft @ _____ CPM
- * Transient Shock: Magnitude: _____ lb-ft
- Duration: _____ milliseconds
- How Often: _____ times per hour
- * Briefly describe any peculiarities or special circumstances of the dyanmic system _____
- _____
- _____

*** Required data**

(OVER)

COUPLING REQUIREMENTS

Primary Function

Shaft Misalignment

- _____ Axial
- _____ Angular
- _____ Parallel
- _____ Torsional Vibration Isolation
- _____ Torsional Shock Loads
- _____ Noise Attenuation

Specific Requirements

- _____ Inches
- _____ Degrees
- _____ Inches
- _____ % Isolation @ _____ RPM
- _____ Maximum Amplitude

Parameters

- * System Operating Temperature: Normal _____ °F Maximum _____ °F Minimum _____ °F
- * Environment: Oil Immersion _____ Oil Splash _____
 Other _____ Mil Spec _____
- * Space Envelope: Maximum Length _____ Maximum Diameter _____
- * Attachments: Driving Spline Flange Driven Spline Flange
 Keyways Set Screws Keyways Set Screws
- * Shaft Diameters: Driving _____ Driven _____
- Fail-Safe Feature Required: Yes No
- Maximum Allowable Weight: _____
- * Minimum Hours Life Required: _____

Please attach the following:

- 1. A layout of the available space envelope and other pertinent drawings showing connecting driveline components.**
- 2. A system mass-elastic diagram including all rotational mass moments of inertia and torsional stiffnesses.**

Remarks _____

*** Required data**

Please return to: LORD Corporation
 2000 West Grandview Blvd.
 P.O. Box 10038
 Erie, PA 16514-0038
 Fax: 814 866 1773