

DYNE X™ ●●●

26" LCD TV

DX-L26-10A

USER GUIDE

Contents

CHILD SAFETY.....	1
Important safety instructions	2
Warnings	2
Cautions	2
Installing the stand or removing the stand column	4
Installing the stand	4
Removing the stand column	5
Installing a wall-mount bracket	5
TV components	6
Front	6
Side	6
Back	7
Remote control	8
Using the remote control	9
Installing remote control batteries	9
Aiming the remote control	9
Programming a universal remote control to work with your TV	9
Making connections	10
Selecting a location	10
Connecting the power	10
Connecting an antenna, cable TV, or satellite TV box	11
Connecting a VCR	11
Connecting a camcorder or game console	11
Connecting an HDMI device	12
Connecting a component video device	12
Connecting an S-Video device	12
Connecting a computer	13
Connecting headphones	13
Connecting an audio amplifier	13
Turning on your TV for the first time	13
Understanding the basics	14
Turning your TV on or off	14
Selecting the video input source	14
On-screen menu overview	15
Navigating the menus	15
Selecting a channel	15
Adjusting the volume	16
Adjusting basic settings	16
Displaying additional information	16
Adjusting the picture	16
Adjusting the TV picture	16
Adjusting Advanced Video settings	17
Adjusting the computer image	17
Adjusting the sound	18
Adjusting the sound	18
Selecting the audio mode	18
Playing TV audio only	18
Changing channel settings	19
Automatically scanning for channels	19
Selecting the signal source	19
Hiding channels	20
Setting up a favorite channel list	20
Adding or changing a channel label	21
Checking the DTV signal strength	21
Setting parental controls	22
Turning parental controls on or off	22

Setting or changing the password	22
Setting parental control levels	23
Downloading rating information	25
Using closed captioning	25
Turning closed captioning on or off	25
Selecting the closed captioning mode	26
Customizing DTV closed captioning styles	27
Adjusting time settings	28
Setting the clock	28
Setting the sleep timer	28
Adjusting menu settings	29
Selecting the menu language and transparency	29
Labeling an input source	29
Restoring default settings	30
Troubleshooting	30
Video and audio	30
Remote control	31
General	31
Maintenance	31
Cleaning	31
Specifications	31
Legal notices	32
One-year limited warranty	33

CHILD SAFETY

It makes a difference how and where you use your flat panel display

As you enjoy your new product, keep these safety tips in mind

The issue

The home theater entertainment experience is a growing trend, and larger TVs are popular purchases. However, TVs are not always supported on the proper stands or installed according to the manufacturer's recommendations. We and the consumer electronics industry are committed to making home entertainment enjoyable and safe.

TVs that are inappropriately placed on dressers, bookcases, shelves, desks, speakers, chests, or carts may fall over and cause injury.

Tune into safety

- One size of TV stand does **not** fit all. Use only a TV stand rated for the weight of your TV.
- Carefully read and understand all enclosed instructions for proper use of this product.
- Don't let children climb on or play with entertainment system furniture and TVs.
- Don't place TVs on furniture that can easily be used as steps, such as a chest of drawers.
- Remember that children can become excited while watching a program, especially on a "larger-than-life" TV. Make sure that you place or install the TV where it cannot be pushed, pulled over, or knocked down.
- Make sure that you route all cords and cables so that they cannot be pulled or grabbed by curious children.



Wall mounting

If you decide to wall mount your TV, always:

- One size of wall mount does **not** fit all. Use only a wall mount rated for the weight of your TV and that has been recommended by this TV manufacturer, listed in this manual, or otherwise listed by an independent laboratory as suitable for your TV.
- Follow all instructions supplied by the TV and wall mount manufacturers.
- If you have any doubts about your ability to safely wall mount your TV, get help from a professional installer.
- Make sure that the wall where you are mounting the TV is appropriate. Some wall mounts are not designed to be mounted to walls backed with steel studs or cinder blocks. If you are unsure, ask a professional installer.
- TVs can be heavy. At least two people are required for safe wall mount installation.



Important safety instructions

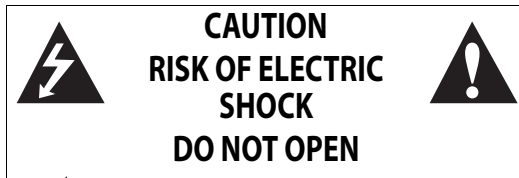

This symbol indicates that dangerous voltage constituting a risk of electric shock is present within your TV. This label is located on the back of your TV.



This symbol indicates that there are important operating and maintenance instructions in the literature accompanying your TV.

- 1 Read these instructions.
- 2 Keep these instructions.
- 3 Heed all warnings.
- 4 Follow all instructions.
- 5 Do not use this apparatus near water.
- 6 Clean only with dry cloth.
- 7 Do not block any ventilation openings. Install in accordance with the manufacturer's instructions.
- 8 Do not install near any heat sources such as radiators, heat registers, stoves, or other apparatus (including amplifiers) that produce heat.
- 9 Do not defeat the safety purpose of the polarized or grounding-type plug. A polarized plug has two blades with one wider than the other. A grounding type plug has two blades and a third grounding prong. The wide blade or the third prong are provided for your safety. If the provided plug does not fit into your outlet, consult an electrician for replacement of the obsolete outlet.
- 10 Protect the power cord from being walked on or pinched particularly at plugs, convenience receptacles, and the point where they exit from the apparatus.
- 11 Only use attachments/accessories specified by the manufacturer.
- 12 Use only with a cart, stand, tripod, bracket, or table specified by the manufacturer, or sold with the apparatus. When a cart is used, use caution when moving the cart/apparatus combination to avoid injury from tip-over. 
- 13 Unplug this apparatus during lightning storms or when unused for long periods of time.
- 14 Refer all servicing to qualified service personnel. Servicing is required when the apparatus has been damaged in any way, such as power-supply cord or plug is damaged, liquid has been spilled or objects have fallen into the apparatus, the apparatus has been exposed to rain or moisture, does not operate normally, or has been dropped.
- 15 The *mains plug* is the disconnecting device. The plug must remain readily operable.
- 16 The apparatus with grounding-type plug is a class I apparatus. Class I apparatus need to be connected to earth ground wire to prevent possible electric shock. Make sure that you connect the class I apparatus to a mains socket outlet with a protective earthing connection.
- 17 Remote control batteries should not be exposed to excessive heat such as sunshine, fire, or the like.

- 18 The apparatus shall not be exposed to dripping or splashing and that no objects filled with liquids, such as vases, shall be placed on the apparatus.

Warnings

Electric shock hazard

To reduce the risk of fire or electric shock, do not remove any cover or expose the device to rain or moisture. No user-serviceable parts are inside. Refer servicing to qualified service technicians.

Lightning

For added protection for your device receiver during a lightning storm, or when it is left unattended and unused for long periods of time, unplug it from the power outlet and disconnect any antenna or cable system. This helps prevent property damage and personal injury from lightning and power line surges.

Power lines

An outside antenna system should not be located in the vicinity of overhead power lines or other electric light or power circuits, or where it can fall into such power lines or circuits. When installing an outside antenna system, extreme care should be taken to keep from touching such power lines or circuits as contact with them might be fatal.

Handling the LCD panel

- Your TV's screen is made of glass. Do not drop your TV or hit, jolt, or press hard against the LCD panel. If the screen breaks, be careful of broken glass.
- If the LCD panel is broken, make absolutely sure that you do not touch the liquid in the panel. This may cause skin inflammation.
- If the liquid gets in your mouth, immediately gargle, rinse, and consult with your doctor. Also, if the liquid gets in your eyes or touches your skin, consult with your doctor after rinsing for at least 15 minutes or longer in clean water.

Replacement parts

When replacement parts are required, make sure that the service technician uses replacement parts specified by the manufacturer that have the same characteristics as the original part. Unauthorized substitutions may result in fire, electric shock, personal injury, or other hazards.

Safety check

After completing any service or repair to this device, ask the service technician to perform routine safety checks to determine that your TV is in correct operating condition.

Power source

Operate your TV only from the type of power source indicated on the marking label. If you are not sure of the type of power supplied to your home, consult an electrician or your local power company.

Water and liquids

The apparatus shall not be exposed to dripping or splashing, and no objects filled with liquids, such as vases, shall be placed on the apparatus.

Cautions

Damage requiring service

Unplug this TV from the power outlet and refer servicing to qualified service personnel under the following conditions:

- When the power supply cord or plug is damaged or frayed.
- If liquid has been spilled or objects have fallen into your TV.
- If your TV has been exposed to rain or water.

- If your TV does not operate normally by following the operating instructions. Adjust only those controls that are covered by the operating instructions because incorrect adjustment of other controls may result in damage and will often require extensive work by a qualified technician to restore your TV to its normal operation.
- If your TV has been dropped or damaged in any way.
- When your TV exhibits a distinct change in performance.

Outdoor antenna grounding

If an outside antenna or cable system is connected to your TV, make sure that the antenna or cable system is grounded to provide some protection against voltage surges and built-up static charges. Article 810 of the National Electrical Code, ANSI/NFPA No. 70, provides information with respect to correct grounding of the mast and supporting structure, grounding of the lead-in wire to an antenna discharge unit, size of grounding conductors, location of the antenna-discharge unit, connection to grounding electrodes, and requirements for the grounding electrode.

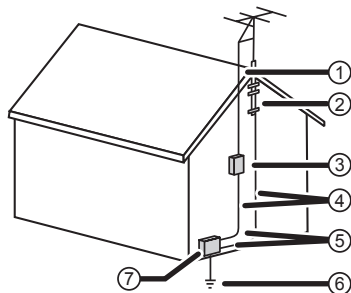

①	Antenna lead-in wire
②	Grounding clamp
③	Antenna discharge unit
④	Grounding conductors
⑤	Ground clamps
⑥	Power service grounding electrode system
⑦	Electric service equipment

Note to CATV system installer

Article 820 of the National Electrical Code, ANSI/NFPA No. 40 provides guidance for correct grounding. Specifically, it states that the cable ground must be connected to the grounding system of the building as close to the point of cable entry as practical.

Condensation

Moisture will form on the TV if the TV is brought from cool surroundings into a warm room or if the temperature of the room rises suddenly. When this happens, the TV's performance may be impaired. To prevent this, let the TV stand in its new surroundings for about an hour before switching it on, or make sure that the room temperature rises gradually. Condensation may also form during the summer if the TV is exposed to the breeze from an air conditioner. In such cases, change the location of the TV.

Mobile telephone warning

To avoid interference with your TV picture and sound, operating problems, or even damage, keep your cordless and cellular telephones away from the TV.

End of life directives

Your TV contains tin-lead solder and a fluorescent lamp containing a small amount of mercury. Disposal of these materials may be regulated for environmental reasons. Your TV also contains material that can be recycled and reused. For disposal or recycling information, contact your local authorities or the Electronic Industries Alliance at www.eia.org to find a recycler in your area.

Non-active pixels

The LCD panel contains almost 3 million thin film transistors, which provide exceptionally sharp video quality. Occasionally, a few non-active pixels may appear on the screen as a fixed blue, green, or red point. These non-active pixels do not adversely affect the performance of your TV, and are not considered defects.

Installing the stand or removing the stand column

Cautions

- Read these instructions carefully before you try to assemble the stand or remove the stand column.
- Make sure that you handle the TV carefully when attempting to assemble or remove the stand. If you are not sure of your ability to do this or to use the tools required, contact a professional installer or service technician. Dynex is not responsible for any damages or injuries that occur because of mishandling or incorrect assembly.
- When using a table or bench as an aid in assembly, make sure that you use a soft cushion or covering to prevent scratching or damage to the TV screen or cabinet.
- The speaker is not intended to support the weight of the TV. Do not move or handle the TV by the speaker. This can cause damage that is not covered by your warranty.
- Before assembly or removal of the stand, unplug the power cord.

You need to install the TV into the stand to use the TV in an upright position on a flat surface. For instructions, see "Installing the stand" on page 4.

If you plan to wall-mount the TV, you need to remove the stand column. For instructions, see "Removing the stand column" on page 5.

Installing the stand

You need to install the stand to use the TV in the upright position on a flat surface.

Note: The appearance of the TV may differ from the illustrations in this task.

To install the stand:

- 1 Remove the stand from the box and place it on a table or bench.
- 2 Lay the TV flat (screen down) on the edge of a table or bench. Make sure that you put a soft cushion or cloth between the table or bench and the TV.

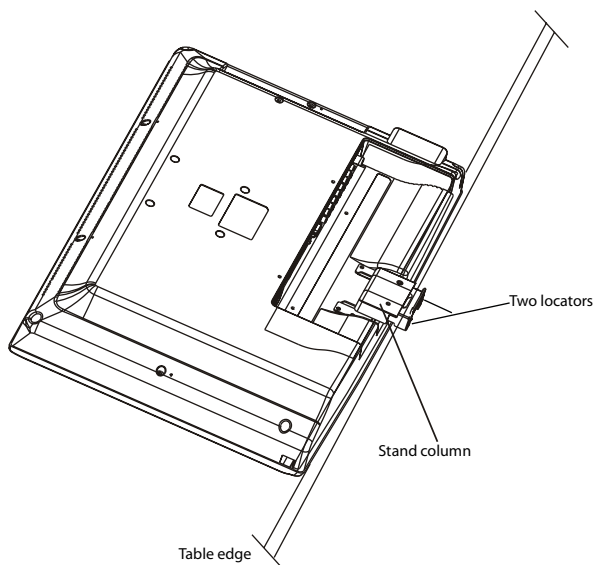

- 3 Examine the stand carefully. The column socket is not in the center of the stand. You need to make sure you align the stand shown in the following illustration.

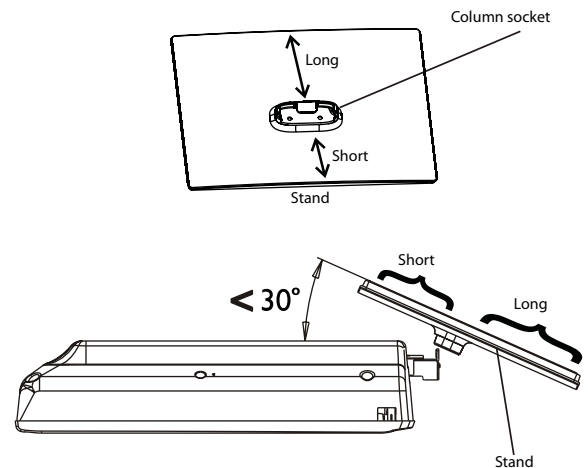

- 4 Place the stand close to the end of the stand column and keep the angle between the TV and the stand at 30° or less, then fully insert the stand column into the column socket on the stand.
- 5 Adjust the stand angle until it is at a 90° angle to the TV.

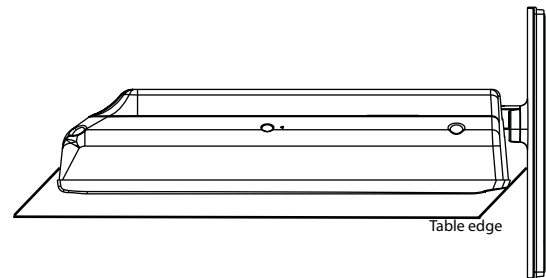

- 6 Move the stand gently until the locators on the stand column align with the locating grooves on the stand, then use four screws (provided) to secure the stand to the column.

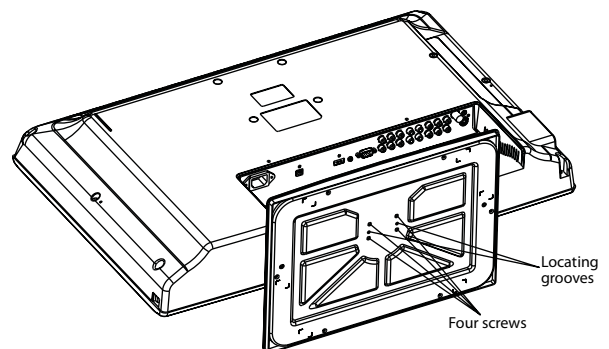

To remove the stand, loosen the four screws.

Removing the stand column

You need to remove the stand column before you wall-mount the TV.

Note: The appearance of the TV may differ from the illustration in this task.

To remove the stand column:

- 1 Lay the TV flat (screen down) on the edge of a table or bench. Make sure that you put a soft cushion or cloth between the table or bench and the TV.
- 2 Remove the four screws holding the stand column to the TV, then remove the stand column.

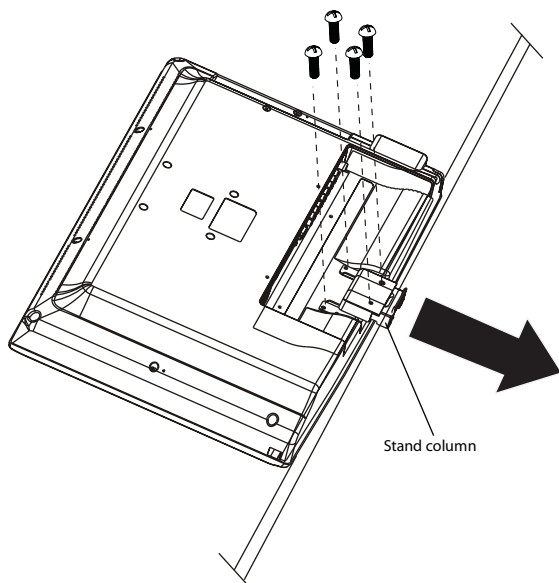

Installing a wall-mount bracket

If you want to attach the TV to a wall-mount bracket (not provided), you should first remove the stand pedestal if it is pre-attached.

To install a wall-mount bracket:

- 1 Lay your TV face down on a table or bench. Make sure that you put down a soft cushion or cloth so that your TV is not scratched).
- 2 Remove the four screws that secure the TV to the base.
- 3 Remove the stand column. See "Removing the stand column" on page 5.
- 4 Secure the wall-mount bracket to the back of your TV.

TV components

Front

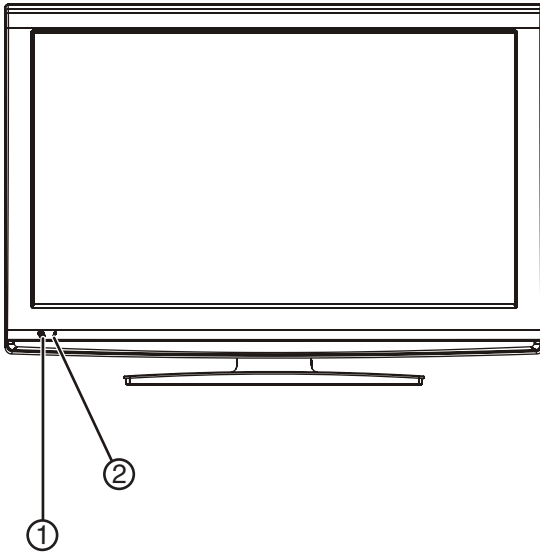

Item	Name	Description
①	Remote control sensor	Receives signals from the remote control. Do not block. For more information, see "Aiming the remote control" on page 9.
②	Power indicator	Lights blue when your TV is turned on. Lights red when your TV is in standby mode.

Side

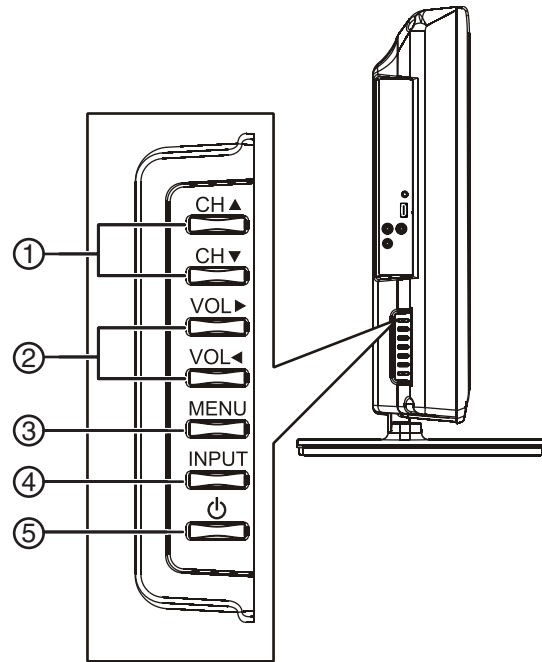

Item	Name	Description
①	CH ▲ / CH ▼	In TV mode, press to select the next or previous channel. In menu mode, press to move up or down.
②	VOL ► / VOL ◀	In TV mode, press to increase or decrease the volume. In menu mode, press to move right or left or to adjust menu settings.
③	MENU	Press to open the on-screen menu.
④	INPUT	Press to open the INPUT SOURCE menu. For more information, see "Selecting the video input source" on page 14.
⑤	⏻ (power)	Press to turn on the TV or put the TV in standby mode. Caution: When the TV is in standby mode, power is still flowing into the TV. To disconnect power, unplug the power cord.

Back

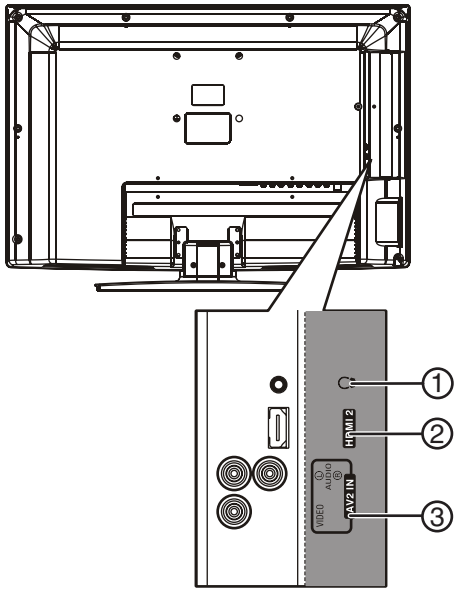

Item	Name	Description
①	Ⓜ (headphone)	Plug headphones into this jack. For more information, see "Connecting headphones" on page 13.
②	HDMI 2	Connect an HDMI device to this jack.
③	AV2 IN VIDEO / AUDIO L and R	Connect a standard AV device, such as a camcorder or game console, to these jacks. For more information, see "Connecting a camcorder or game console" on page 11.

Item	Name	Description
①	AC IN	Plug the power cord into this jack and into a power outlet. For more information, see "Connecting the power" on page 10.
②	SERVICE PORT	For software updates only. Do not use.
③	HDMI 1	Connect an HDMI device to this jack. For more information, see "Connecting an HDMI device" on page 12.
④	VGA AUDIO / PIC	Connect a computer to these jacks. For more information, see "Connecting a computer" on page 13.
⑤	COMPONENT IN with AUDIO R / L	Connect a component video device to these jacks. For more information, see "Connecting a component video device" on page 12.
⑥	AV1 IN with AUDIO R / L	Connect a standard video device to these jacks, such as a VCR. For more information, see "Connecting a VCR" on page 11.
⑦	AUDIO OUT R / L	Connect an external sound system to these jacks. For more information, see "Connecting an audio amplifier" on page 13.
⑧	RF	Connect an antenna or cable TV to this jack. For more information, see "Connecting an antenna, cable TV, or satellite TV box" on page 11.
⑨	S-VIDEO	Connect an S-Video device to this jack. For more information, see "Connecting an S-Video device" on page 12.
⑩	RS-232	For service only. Do not use.

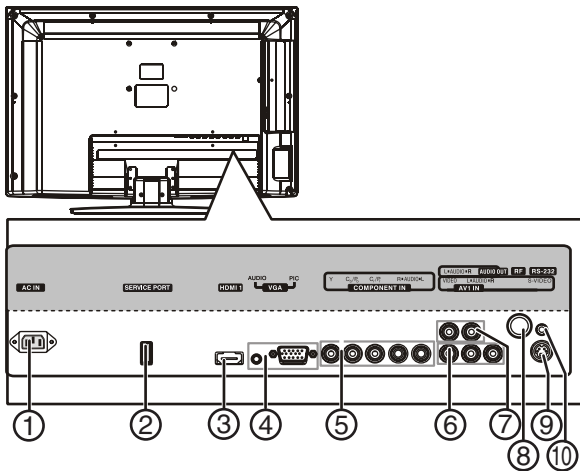

Remote control

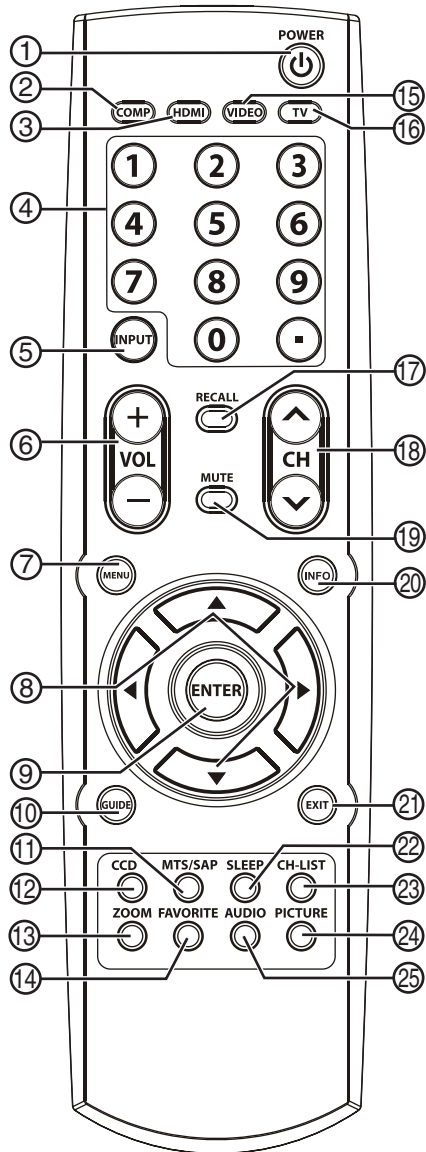

Item	Name	Description
①	POWER	Press to turn on the TV or put the TV in standby mode. Caution: When the TV is in standby mode, power is still flowing into the TV. To disconnect power, unplug the power cord.
②	COMP	Press to select the device connected to the COMPONENT IN jacks.
③	HDMI	Press once to select the device connected to the HDMI 1 jack. Press twice to select the device connected to the HDMI 2 jack.
④	Numbers / ●	Press the number buttons to enter channel numbers or the parental control password. Press ● to enter a digital sub-channel number. For more information, see "Selecting a channel" on page 15.

Item	Name	Description
⑤	INPUT	Press to open the INPUT SOURCE menu. For more information, see "Selecting the video input source" on page 14.
⑥	VOL+ / VOL-	Press to increase or decrease the volume.
⑦	MENU	Press to open the on-screen menu.
⑧		Press ▲ or ▼ to move up or down in on-screen menus. Press ◀ or ▶ to move left or right in on-screen menus or to adjust menu settings.
⑨	ENTER	Press to confirm selections in on-screen menus or to open sub-menus.
⑩	GUIDE	Press to open a program guide (if available) when watching a DTV program. The guide may provide program broadcast times and program names. For more information, see "Displaying additional information" on page 16.
⑪	MTS/SAP	In analog TV mode, press to select STEREO , SAP (secondary audio language), or MONO . In digital TV mode (DTV), press to select the audio track. For more information, see "Selecting the audio mode" on page 18.
⑫	CCD	Press to turn closed captioning on or off. For more information, see "Turning closed captioning on or off" on page 25.
⑬	ZOOM	Press to select the screen aspect ratio. For more information, see "Adjusting Advanced Video settings" on page 17.
⑭	FAVORITE	Press to open the favorite channel list. For more information, see "Setting up a favorite channel list" on page 20.
⑮	VIDEO	Press once to select the device connected to the AV1 IN jacks. Press twice to select the device connected to the AV2 IN jacks. Press three times to select the device connected to the S-VIDEO jack. For more information, see "Selecting the video input source" on page 14.
⑯	TV	Press to select TV as the video input source. For more information, see "Selecting the video input source" on page 14.
⑰	RECALL	Press to go to the last viewed channel. For more information, see "Selecting a channel" on page 15.
⑱	CH ^ / CH v	Press to go to the next or previous channel in the channel list. For more information, see "Automatically scanning for channels" on page 19 and "Selecting a channel" on page 15.
⑲	MUTE	Press to mute the sound. Press again to restore the sound.

Item	Name	Description
⑳	INFO	Press to display the information banner. For more information, see "Displaying additional information" on page 16.
㉑	EXIT	Press to close the on-screen menu.
㉒	SLEEP	Press to set the sleep timer. For more information, see "Setting the sleep timer" on page 28.
㉓	CH-LIST	Press to open the channel list. For more information, see "Automatically scanning for channels" on page 19.
㉔	PICTURE	Press to select the picture mode. For more information, see "Adjusting the TV picture" on page 16.
㉕	AUDIO	Press to select the audio mode. You can select News , Music , Movie , or Custom . For more information, see "Adjusting the sound" on page 18.

Using the remote control

Installing remote control batteries

To install remote control batteries:

- 1 Press down on the battery compartment cover lock, then remove the remote control cover.

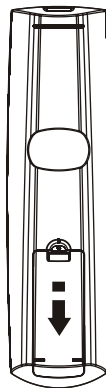

- 2 Insert two AAA batteries into the battery compartment. Make sure that the + and – symbols on the batteries match the + and – symbols in the battery compartment.
- 3 Replace the cover. Make sure that the lock snaps into place.

Battery precautions:

- Dispose of batteries as hazardous waste.
- Make sure that the + and – symbols on the batteries align with the + and – symbols in the battery compartment.
- Do not mix batteries of different types.
- Do not mix old and new batteries. Mixing old and new batteries can shorten the life of new batteries and can cause old batteries to leak.
- Remove batteries as soon as they become inoperable. Chemicals that can leak from the batteries can cause a rash. If the batteries leak, clean the battery compartment with a cloth.
- If the remote control is not used for an extended period of time, remove the batteries.
- Do not expose batteries to excessive heat such as sunshine, fire, or other heat sources.

Aiming the remote control

To aim the remote control:

- Point the remote control towards the remote sensor on the front of your TV.

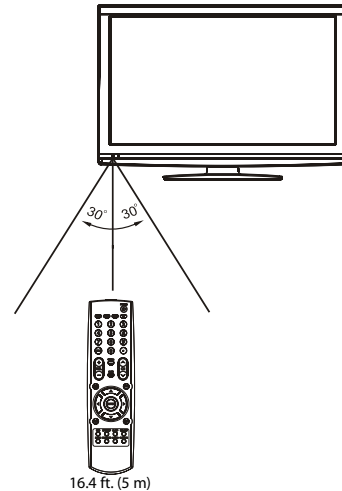

Notes:

- Do not expose the remote control to shock or liquids.
- Do not use the remote control in an area with high humidity.
- Do not place the remote control in direct sunlight.
- Do not place objects, such as furniture, between the remote control and the remote sensor.
- The remote control may not work if direct sunlight or bright light shines on the remote sensor. Either move your TV or change the angle at which you use the remote control.

Programming a universal remote control to work with your TV

You can operate your TV with a new or existing universal remote control.

To program a universal remote control:

- 1 Find the code for your universal remote control by identifying its model (or your set-top box's remote control manufacturer and model) on the charts below, then make note of the numbered code below it. You will use the numbered code to program your remote control to work with your TV.

Dynex TV codes for universal remote controls (for all Dynex TVs manufactured after Jan. 1, 2007)

Universal remote control manufacturer and model

Philips PHDVD5, PH5DSS, PMDVR8, PDVR8	DirectTV RC23	RCA RCU807	One for All URC-6690	Sony RM-VL600
---------------------------------------	---------------	------------	----------------------	---------------

115	10463	135	0464	8043
------------	--------------	------------	-------------	-------------

Set-top box manufacturer and model

Comcast M1057	Dish Network VIP508, VIP622	Motorola DRC800	TIVO Series 3, HD
---------------	-----------------------------	-----------------	-------------------

0463	720	0463	0091
-------------	------------	-------------	-------------

Codes for other remote controls are available online at:
www.dynexproducts.com/t-customer_support.aspx

Tips:

- The brand name is often visible on the front of the universal remote control, and the model number is often visible on the back.
 - If your universal remote control isn't listed on the chart, refer to your universal remote control's instructions and try codes for the brands Orion, Emerson, Memorex, Sansui, Sylvania, or Zenith. You may need to try several codes before finding a match.
- 2 Follow your universal remote control's instructions to enter the code you found in Step 1.

Tips:

- If your universal remote control has a code search feature, run a code search to identify a code that matches your TV. See your universal remote control's instructions for details.
 - If your universal remote control has a "Learn" feature, you can manually program it using your TV remote to "teach" the commands one at a time. See your universal remote control's instructions for details.
- 3 If all else fails, you must use a different universal remote control that can operate both your set-top box and your TV. Five such remotes are listed on the chart, but many other compatible models are available in the market.
- 4 For more help, call technical support for your universal remote control or set-top box manufacturer, or call the Dynex Customer Care Center at 1-800-305-2204.

Making connections

Before you make any connections:

- Check the plugs on the ends of cables to make sure that they are the connect type before you trying plugging them into jacks on the TV.
- Make sure that all plugs are securely inserting into the jacks. Loose connections can result in image or color problems.
- When connecting devices to the TV, make sure that the TV and the device are turned off and that the power cords are unplugged.

Selecting a location

You should select a location for the TV:

- Where direct light does not reflect on the screen
- That has indirect and soft lighting
- Where the TV has access to an antenna or cable TV connection
- Where the TV has access to a power outlet

Note: Watching TV in total darkness or with a reflection on the screen may cause eye strain.

Connecting the power

To connect the power cord:

- Connect the power cable to the **AC IN** jack on the back of the TV, then connect the other end to a power outlet.

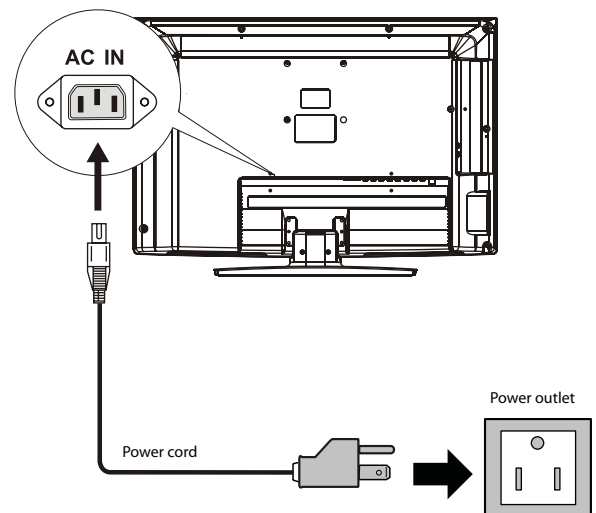
**Notes:**

- The AC plug on the TV may be different from the one shown.
- Make sure that you only use the type of power source indicated on the marking label.
- Always unplug the power cord when not using the TV for a long period of time.

Connecting an antenna, cable TV, or satellite TV box

To connect an antenna, cable TV, or satellite TV box:

- Connect one end of a 75-Ohm coaxial cable to the RF jack on the back of the TV, then connect the other end of the cable to the antenna or cable TV wall jack.

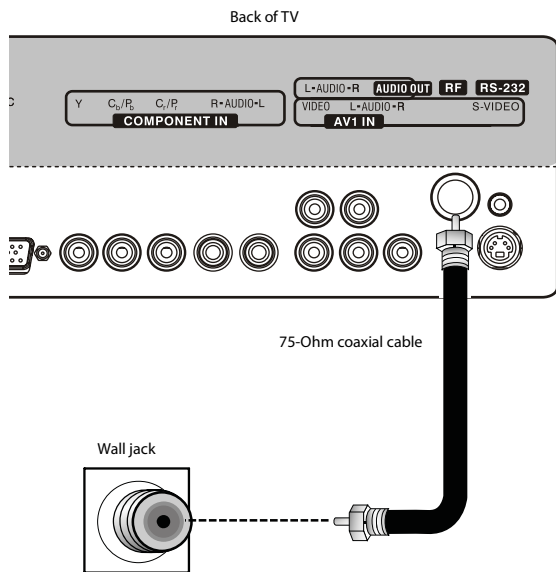

Notes:

- We recommend using a 75-Ohm, coaxial cable to reduce interference and noise that may be caused by radio wave transmissions.
- Do not bundle the coaxial cable with the power cord or any other cables.
- If you are using an antenna and reception is not good, contact a service technician to adjust the antenna.

Connecting a VCR

Note: If the VCR has an S-Video jack, connect the VCR using the S-Video jack. S-Video provides better video than standard AV. For more information, see "Connecting an S-Video device" on page 12.

To connect a VCR:

- Connect one end of a standard AV cable (not included) into the **AV1 IN** jacks on the back of the TV, then connect the other end of the cable to the **AV OUT** jacks on the VCR.

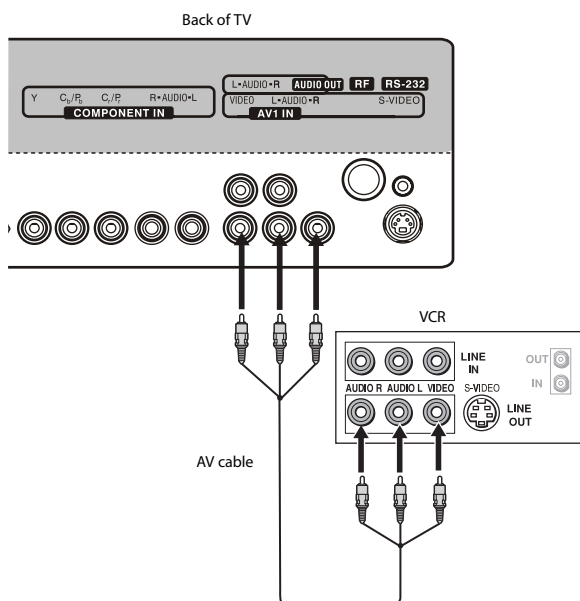

Note: Cable connectors and jacks are often color-coded. Match the colors when you connect the AV cable.

To play the VCR:

- 1 Turn on the TV, then press **INPUT**. The **INPUT SOURCE** menu.
- 2 Press **▲** or **▼** to select **AV1**, then press **ENTER**.
Note: You can also press **VIDEO** one or more times to select **AV1**.
- 3 Turn on the VCR, insert a videotape, then press **PLAY** on the VCR.

Connecting a camcorder or game console

Note: If your game console has an HDMI connection, you will get better quality using the HDMI connection instead of the AV connection.

To connect a camcorder or game console:

- Connect one end of a standard AV cable into the **AV2 IN** jacks on the side of the TV, then connect the other end of the cable to the **AV OUT** jacks on the camcorder or game console.

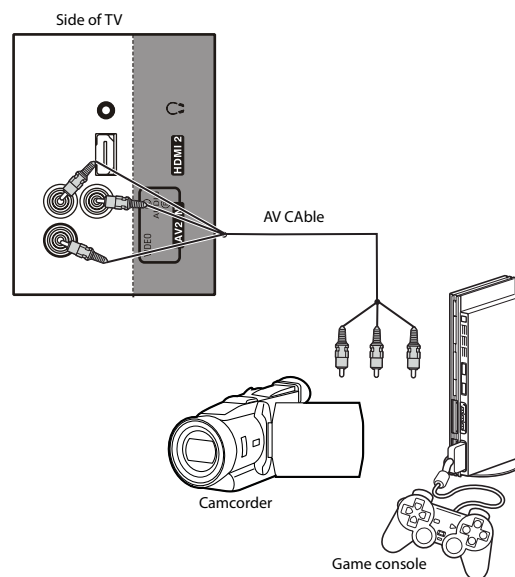

Note: Cable connectors and jacks are often color-coded. Match the colors when you connect the AV cable.

To playback the camcorder or play the game console:

- 1 Turn on the TV, then press **INPUT**. The **INPUT SOURCE** menu opens.
- 2 Press **▲** or **▼** to select **AV2**, then press **ENTER**.
Note: You can also press **VIDEO** one or more times to select **AV2**.
- 3 Turn on the camcorder or game console, then follow the instructions that came with the device to play from the camcorder or game console.

Connecting an HDMI device

To connect an HDMI device:

- Connect one end of an HDMI cable (not included) to the **HDMI 1** jack on the back of the TV, then connect the other end of the cable to the **HDMI OUT** jack on the HDMI device.

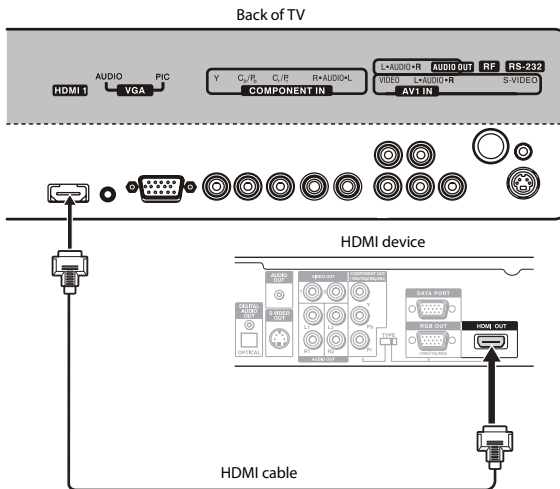

Note: You can also connect an HDMI device to the **HDMI 2** jack on the side of the TV.

Note: To connect a DVI device, use a DVI to HDMI adapter cable to connect to the **HDMI** jack on the TV, then connect an audio cable to the **VGA AUDIO** jack on the back of the TV.

To play from the HDMI device:

- Turn on the TV, then press **INPUT**. The **INPUT SOURCE** menu opens.
- Press **▲** or **▼** to select **HDMI 1** or **HDMI 2**, then press **ENTER**.
Note: You can also press **HDMI** one or more times to select **HDMI 1** or **HDMI 2**.
- Turn on the HDMI device, then set it to the correct mode. Refer to the instructions that came with the HDMI device.

Connecting a component video device

To connect a component video device:

- Connect a component video cable (not included) to the **COMPONENT IN** jacks on the back of the TV.

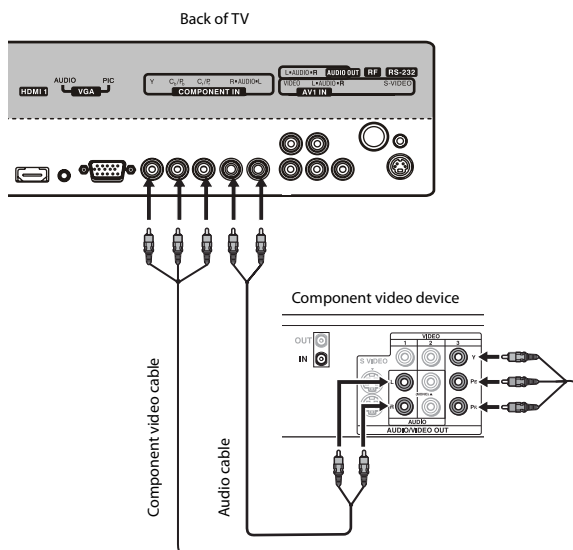

- Connect one end of an audio cable (not included) to the **L and R AUDIO** jacks next to the **COMPONENT IN** video jacks on the back of the TV, then connect the other end of the cable to the **L and R AUDIO OUT** jacks on the component video device.

To play from the component video device:

- Turn on the TV, then press **INPUT**. The **INPUT SOURCE** menu opens.
- Press **▲** or **▼** to select **Component**, then press **ENTER**.

Note: You can also press **COMP** to select **Component**.

- Turn on the component video device, then set it to the correct mode. Refer to the instructions that came with the component video device.

Connecting an S-Video device

Note: The **AV1 VIDEO** and **S-VIDEO** jacks share the same **L and R AUDIO** jacks.

To connect an S-Video device:

- Connect one end of an S-Video cable (not included) to the **AV1 IN S-VIDEO** jack on the back of the TV, then connect the other end of the cable to the **S-VIDEO OUT** jack on the S-Video device.

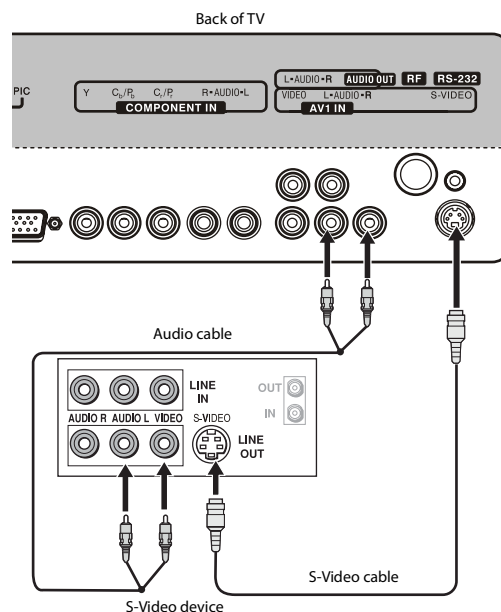

- Connect one end of an audio cable (not included) to the **AV1 IN L and R AUDIO** jacks on the back of the TV, then connect the other end of the cable to the **AUDIO OUT** jacks on the S-Video device.

To play from the S-Video device:

- Turn on the TV, then press **INPUT**. The **INPUT SOURCE** menu opens.
- Press **▲** or **▼** to select **S-Video**, then press **ENTER**.
Note: You can also press **VIDEO** one or more times to select **S-Video**.
- Turn on the S-Video device, then set it to the correct mode. Refer to the instructions that came with the S-Video device.

Connecting a computer

To connect a computer:

- 1 Connect one end of a VGA cable (not included) to the **VGA PIC** jack on the back of the TV, then connect the other end of the cable to the **VGA** jack on the computer.

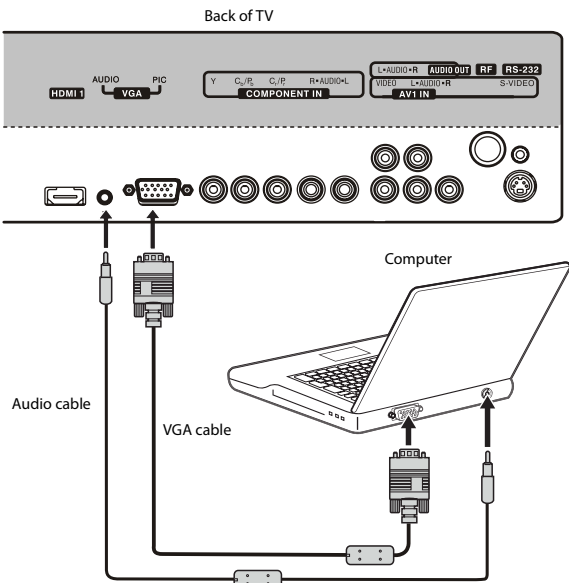

- 2 Connect one end of an audio cable (not included) to the **VGA AUDIO** jack on the back of the TV, then connect the other end of the cable to the **AUDIO OUT** jack on the computer.

To play video from the computer:

- 1 Turn on the TV, then press **INPUT**. The **INPUT SOURCE** menu opens.
- 2 Press **▲** or **▼** to select **VGA**, then press **ENTER**.
- 3 Turn on the computer, then adjust the computer display properties as needed.

Connecting headphones

Warning: When using headphones, adjust the headphone volume to avoid excessively loud volume which can damage your hearing.

To connect headphones:

- Plug the headphones (not included) into the **Ⓞ** (headphone) jack on the side of the TV.

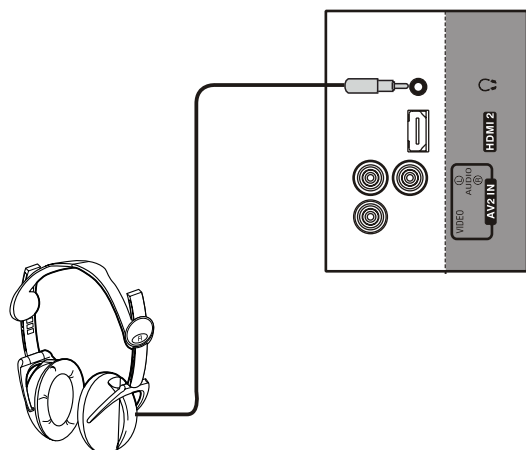

Connecting an audio amplifier

You can connect the TV to an audio amplifier to play the TV audio through external speakers.

To connect an audio amplifier:

- Connect one end of an audio cable to the **AUDIO OUT** jacks on the back of the TV, then connect the other end of the cable to the **AUDIO IN** jacks on the audio amplifier.

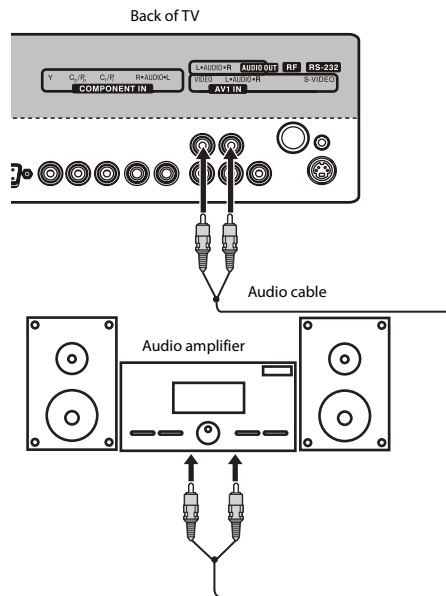

Note: Cable connectors and jacks are often color-coded. Match the colors when you connect the AV cable.

To play the TV audio system through the audio amplifier:

- 1 Turn on the TV, then select a program.
- 2 Turn on the audio amplifier, then adjust the volume and other audio settings using the amplifier controls.

Turning on your TV for the first time

To configure your TV:

- 1 Make sure that you have inserted the batteries in the remote control, connected the antenna to the TV, and connect the AC power.
- 2 Press **⏻** (Power), then wait several seconds. The initial **Setup Wizard** screen opens (only the first time you turn on your TV).

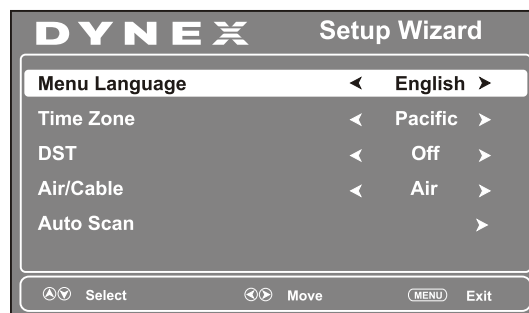

- 3 Press **▲** or **▼** to highlight **Menu Language**, then press **◀** or **▶** to select the menu language you want.

- 4 Press ▼ to highlight **Time Zone**, then press ◀ or ▶ to select your time zone.

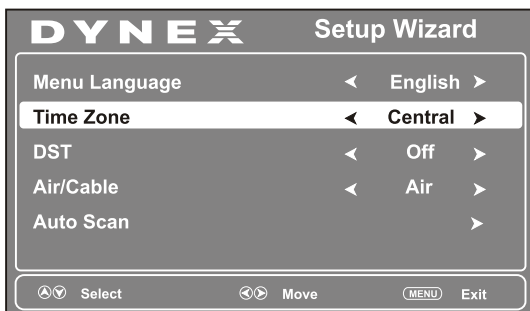

- 5 Press ▼ to highlight **DST** (Daylight Saving Time), then press ◀ or ▶ to select **On** (to automatically change the time for Daylight Saving Time), or **Off** (to ignore it or set it yourself).

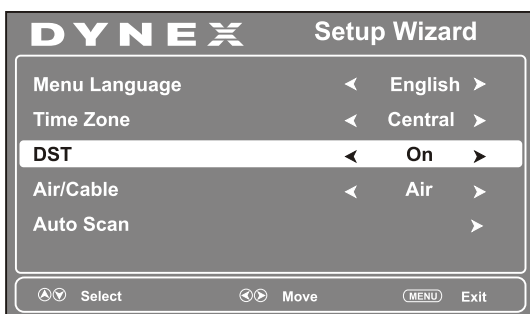

- 6 Press ▼ to highlight **Air/Cable**, then press ◀ or ▶ to select **Air** or **Cable**, depending on the type of antenna connection you have.

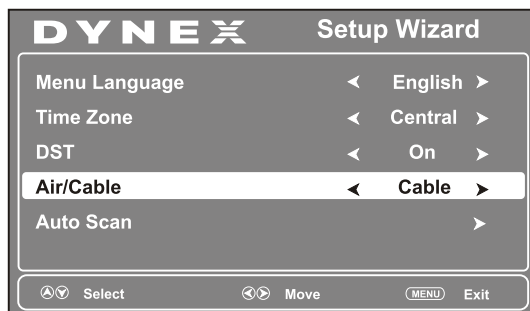

- 7 Press ▼ to highlight **Auto Scan**, then press **ENTER** or ▶ to automatically scan for available channels.

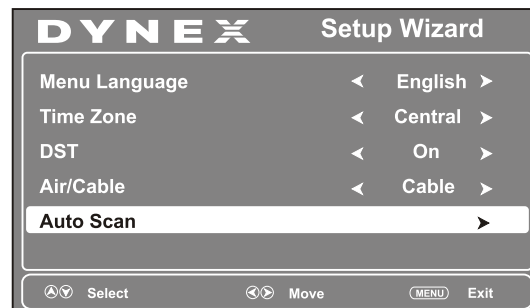

Auto Scan may take a while to complete. A progress report is displayed while your TV is scanning for available channels. You can press **MENU** to exit Auto Scan prior to completion, but you will need to run Auto Scan later to complete the process.

Auto Scan creates a list of available/receivable channels for the selected signal input.

Understanding the basics

Turning your TV on or off

To turn your TV on or off (standby mode):

- 1 Plug the power cord into an AC power outlet.
- 2 Press ⏻ (power). Your TV turns on.
- 3 Press ⏻ again to turn off your TV. When you turn off your TV, it goes into standby mode.

Warning: When your TV is in standby mode, it is still receiving power. To completely disconnect power, unplug the power cord.

Note: If your TV does not receive an input signal for several minutes, it automatically goes into standby mode.

Selecting the video input source

To select the video input source:

- 1 Turn on your TV, then press the **INPUT** key on the remote, or the **INPUT** button on the TV. The **INPUT SOURCE** menu opens.

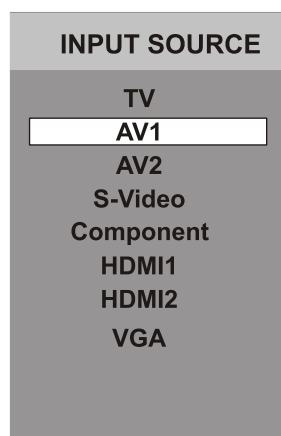

- 2 Press ▲ or ▼ to highlight the video source, then press **ENTER**. You can also select the input source using the following remote control buttons:
 - **COMP**—Press to select **Component**.
 - **HDMI**—Press once to select **HDMI1**. Press twice to select **HDMI2**.
 - **VIDEO**—Press once to select **AV1**. Press twice to select **AV2**. Press three times to select **S-Video**.
 - **TV**—Press to select **TV**.

On-screen menu overview

Picture menu

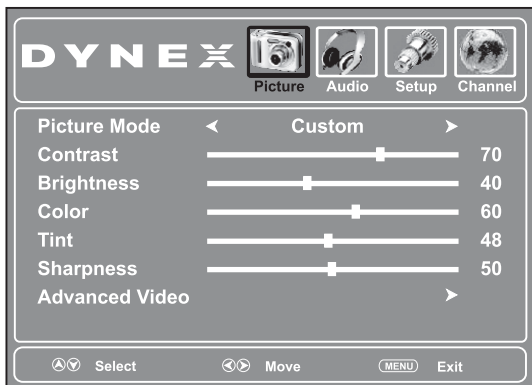

Audio menu

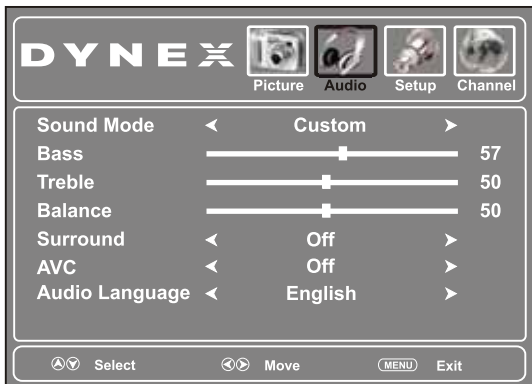

Setup menu



Channel menu

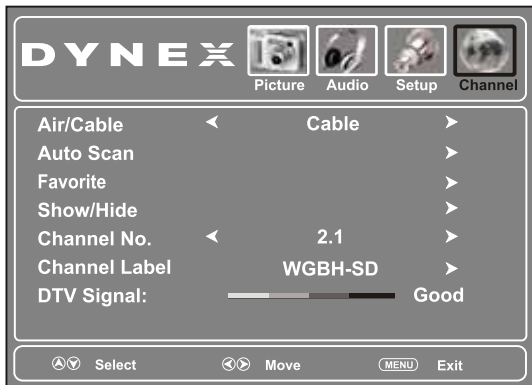

Notes:

Depending on the signal source selected, you may see different options on your screen. The above menus are shown in TV mode.

Menu items that are not selectable are grayed out. Menus in this manual are described in TV mode, unless otherwise indicated.

The illustrations and screens shown in the manual are for explanation purposes and may vary from the actual screens on your TV.

Navigating the menus

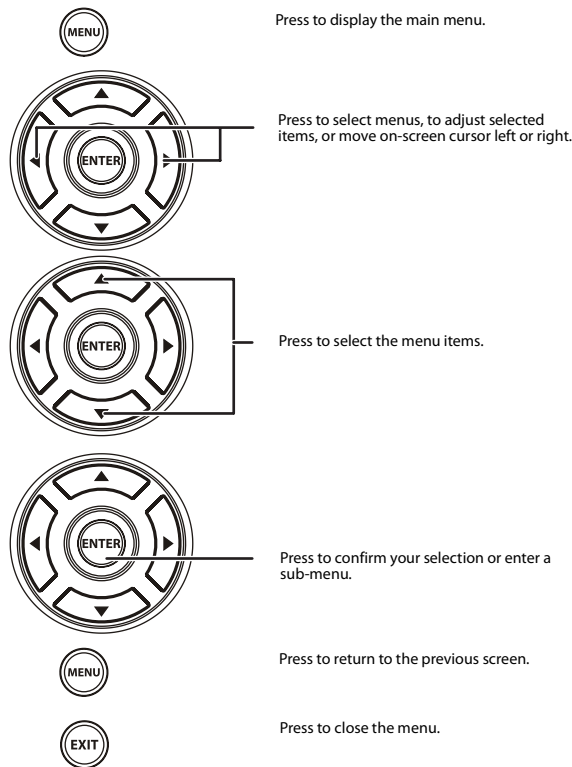

Selecting a channel

To select a channel:

- Press **CH** \blacktriangle or **CH** \blacktriangledown to go to the next or previous channel on the memorized channel list.
- Press the number buttons to enter the analog or digital (main) channel number you want, then wait for the channel to change, or press **ENTER** to change the channel immediately.
- To select a digital sub-channel, press the number buttons to select the main digital channel, then press the dot (.) button to select the sub-channel. Wait for the channel to change, or press **ENTER** to change the channel immediately.

Note:

Button presses must be within three seconds of each other.

- Press **RECALL** to go to the last channel viewed.
- Press **CH-LIST** to display a list of memorized channels, press \blacktriangle or \blacktriangledown to select the channel you want from the list, then press **ENTER** to go to that channel.
- Press **FAVORITE** to display a list of your saved favorite channels, press \blacktriangle or \blacktriangledown to select the channel you want from the list, then press **ENTER** to go to that channel.

Note:

If either list has more than one page, press \blacktriangleleft or \blacktriangleright to scroll through the pages.

Digital sub-channels

A digital TV signal transmits more data than an analog signal. This increase in data provides a better picture and sound with less static and interference. The increased data capacity also lets broadcasters fit several channels into the same bandwidth as an analog signal. Broadcasters may use these sub-channels to transmit a variety of information, such as weather forecasts, foreign languages, and commercials. A digital sub-channel is indicated by the main channel number, followed by a dot, then the sub-channel number. For example, 5.1 indicates sub-channel 1 of main channel 5.

Adjusting the volume

To adjust the volume:

- Press **VOL+** or **VOL-** to increase or decrease the volume.
- Press **MUTE** to temporarily turn off all sound. Press **MUTE** again to restore the sound.

Adjusting basic settings

To adjust basic settings:

- 1 Press **MENU**. The on-screen menu opens with the *Picture* menu displayed.

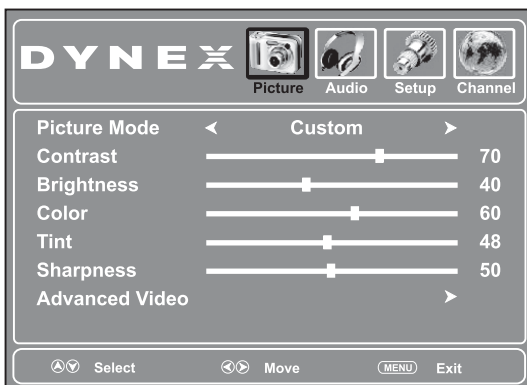

- 2 Press **◀** or **▶** to highlight **Setup**, then press **▼**. The *Setup* menu opens.



- 3 Press **▲** or **▼** to highlight an option, then press **ENTER** to enter the sub menu. You can select:
 - **Parental Controls**—Lets you control which programs/movies your children can watch, based on industry ratings.
 - **Time**—Lets you set the clock and the sleep timer.
 - **Closed Caption**—Lets you turn closed captioning on or off. Also lets you set closed caption options.
 - **Menu Settings**—Lets you set menu language and menu transparency.

- **VGA Settings**—Lets you adjust picture settings to optimize a computer display.
 - **Input Label**—Lets you label a device connected to your TV's input jacks.
 - **Restore Default**—Lets you reset most TV settings for the current source to factory default values.
 - **Audio Only**—Lets you turn off the TV picture and listen to audio only.
- 4 Press **MENU** to return to the previous menu, or press **EXIT** to close the menu.

Displaying additional information

To display additional information:

- 1 Press **INFO** to show an information banner. The information banner shows current program information such as channel number, video input source, and resolution.
 - **Digital mode information**—Displays channel number, station name, channel label (if preset), broadcast program name, TV rating, signal type, audio information, resolution, CC mode, current time, and current program start and end times.
 - **Analog mode information**—Displays channel number, channel label (if preset), signal type, audio information, and resolution.
- 2 Press **GUIDE** to show the digital program guide, which may show a list of available programs, program times, and program summaries, depending on the information provided by the broadcaster.

Adjusting the picture

Adjusting the TV picture

To adjust the picture:

- 1 Press **MENU**. The on-screen menu opens with the *Picture* menu displayed.

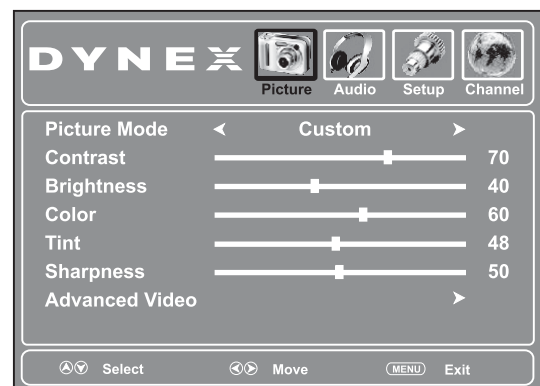

- 2 Press **▲** or **▼** to highlight an option, then press **◀** or **▶** to adjust the option. You can select:
 - **Picture Mode**—Selects the picture mode. You can select **Vivid** (a bright and vivid picture), **Standard** (a standard picture), **Sports** (a dynamic picture), **Theater** (a finely detailed picture), **Energy Saving** (the backlight brightness is decreased), or **Custom** (customized picture). You can also press **PICTURE** on the remote control to select the picture mode.
 - **Contrast**—Adjusts the contrast.
 - **Brightness**—Adjusts the brightness.

- **Color**—Adjusts the color saturation.
 - **Tint**—Adjusts the image tint.
 - **Sharpness**—Adjusts the sharpness.
 - **Advanced Video**—Lets you adjust the Color Temperature or Zoom Mode. Lets you turn Noise Reduction, Overscan, Adaptive Contrast, and Auto Zoom on or off.
- 3 Press **MENU** to return to the previous menu, or press **EXIT** to close the menu.

Adjusting Advanced Video settings

To adjust the Advanced Video settings:

- 1 Press **MENU**. The on-screen menu opens with the *Picture* menu displayed.

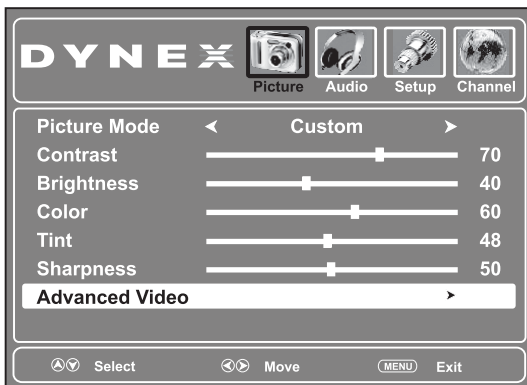

- 2 Press **▲** or **▼** to highlight **Advanced Video**, then press **ENTER** to open the *Advanced Video* sub menu.

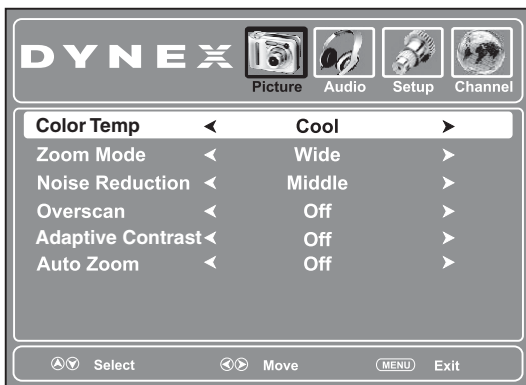

- 3 Press **▲** or **▼** to highlight an option, then press **◀** or **▶** to adjust the option. You can select:

- **Color Temp**—Selects the color temperature. You can select **Warm** (to enhance the reds), **Cool** (to enhance the blues), or **Normal**.
- **Zoom Mode**—Selects the aspect ratio of the picture. You can select **Auto** (selects the correct aspect ratio automatically. Available only when **Auto Zoom** is turned **ON**), **Normal** (selects the correct aspect ratio to match the source image), **Wide** (shows a full-screen picture), **Zoom** (enlarges the picture but may crop the top and bottom), or **Cinema** (stretches the picture at the edges, but maintains a good aspect ratio at the center of the screen).
- **Noise Reduction**—Selects the noise reduction mode to reduce picture noise (snow). You can select **Weak**, **Middle**, **Strong**, or **Off**.
- **Overscan**—Turn this **On** to adjust the picture's reproduction rate when receiving DVI signals in VIDEO format.

- **Adaptive Contrast**—Turn this **On** to optimize the picture display for a more vivid image.
 - **Auto Zoom**—In TV mode, setting Auto Zoom to **On** lets you set the Zoom Mode to **Auto**.
- 4 Press **MENU** to return to the previous menu, or press **EXIT** to close the menu.

Adjusting the computer image

To adjust the computer image:

- 1 Make sure that your TV is in VGA mode. For more information, see "Selecting the video input source" on page 14.
- 2 Press **MENU**. The on-screen menu opens.

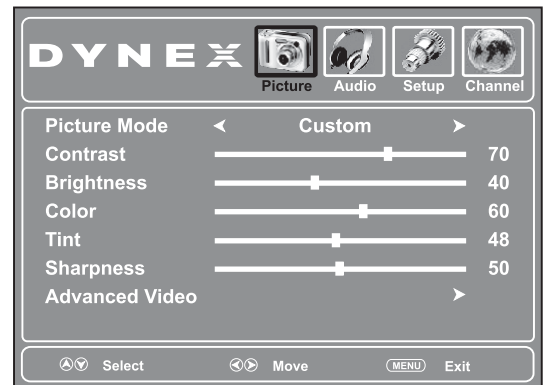

- 3 Press **◀** or **▶** to highlight **Setup**, then press **▼**. The *Setup* menu opens.

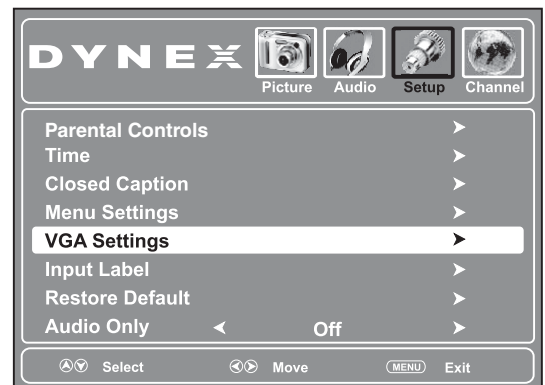

- 4 Press **▲** or **▼** to highlight **VGA Settings**, then press **▼**. The VGA settings menu opens.

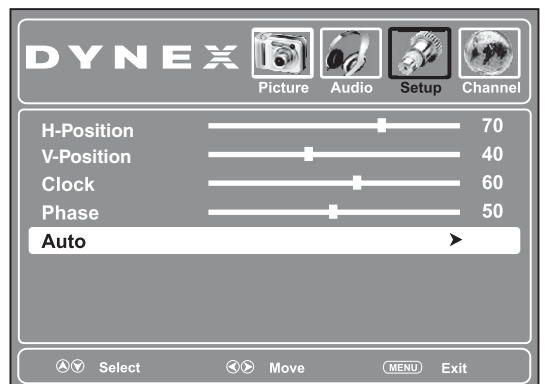

- Press **▲** or **▼** to highlight an option, then press **◀** or **▶** to adjust the option. You can adjust:
 - **H-Position**—Moves the image right or left
 - **V-Position**—Moves the image up or down
 - **Clock**—Adjusts the sample frequency
 - **Phase**—Adjusts the focus of stable images
 - **Auto**—Automatically adjusts the image settings such as position and phase
- Press **MENU** to return to the previous menu, or press **EXIT** to close the menu.

Adjusting the sound

Adjusting the sound

To adjust the sound:

- Press **MENU**. The on-screen menu opens.

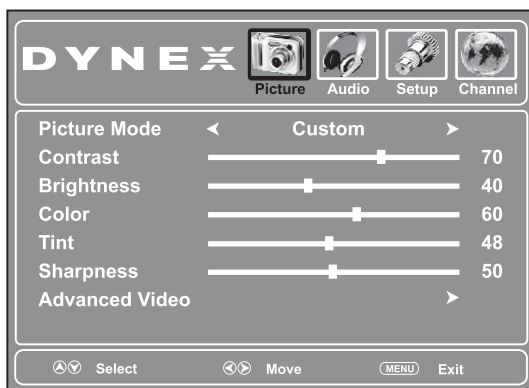

- Press **◀** or **▶** to highlight **Audio**, then press **▼**. The *Audio* menu opens.

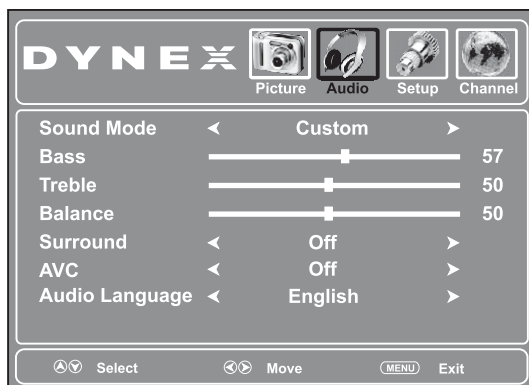

- Press **▲** or **▼** to highlight an option, then press **◀** or **▶** to adjust the option. You can select:
 - **Sound Mode**—Selects the sound mode. You can select **Standard** (for normal programs), **News** (for news programs), **Music** (for musical programs), **Movie** (for movies), or **Custom** (for a customized sound mode). You can also press **AUDIO** one or more times to select the sound mode.
 - **Bass**—Adjusts the low sounds.
 - **Treble**—Adjusts the high sounds.
 - **Balance**—Adjusts the balance between the left and right audio channels.

- **Surround**—Turns the surround sound effect on or off.
 - **AVC**—(Auto volume control) Equalizes the overall volume levels for all channels.
 - **Audio Language**—(DTV channels only) Selects an alternate audio language, if available.
- Press **MENU** to return to the previous menu, or press **EXIT** to close the menu.

Selecting the audio mode

You can select the audio mode for analog channels.

To select the audio mode for analog channels:

- Press **MTS/SAP** on the remote one or more times. You can select:
 - **MONO**—Select this option if there is noise or static on weak stereo broadcasts.
 - **STEREO**—Select this option for programs broadcast in stereo.
 - **SAP**—Select this option to listen to a secondary audio program, if available.

Note: Mono is automatically selected if the program is broadcast in mono.

To select an audio track for a digital channel:

- Press **MTS/SAP**. If an audio track is available, it plays.

Playing TV audio only

You can turn off the picture on your TV and listen to only the program audio.

To play only the TV audio:

- Press **MENU**. The on-screen menu opens.

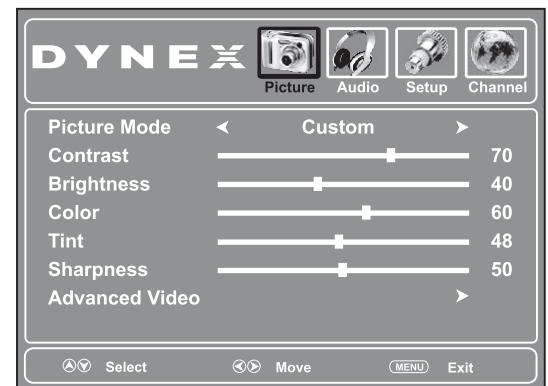

- Press **◀** or **▶** to highlight **Setup**, then press **▼**. The *Setup* menu opens.

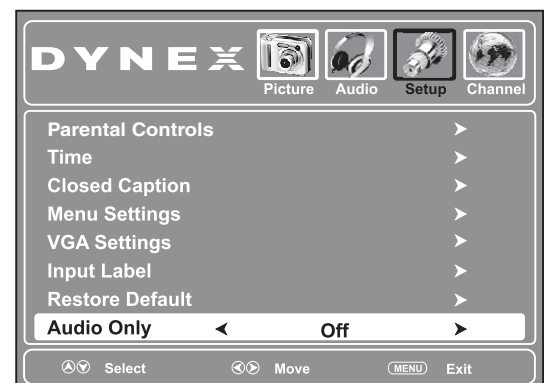

Hiding channels

You can delete channels from the channel list so that your TV skips the channels when you press CH \wedge /CH \vee . You can still tune to the hidden channel by using the number buttons.

To hide a channel:

- 1 Press **MENU**. The on-screen menu opens.

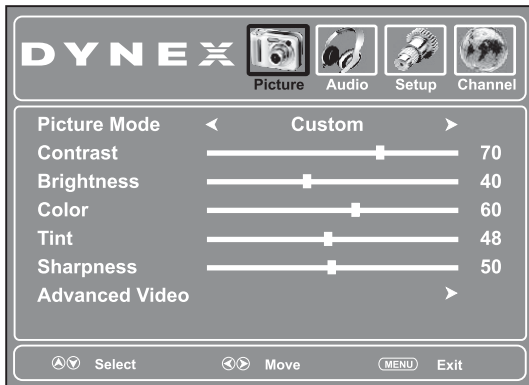

- 2 Press \leftarrow or \rightarrow to highlight **Channel**, then press ∇ . The *Channel* menu opens.

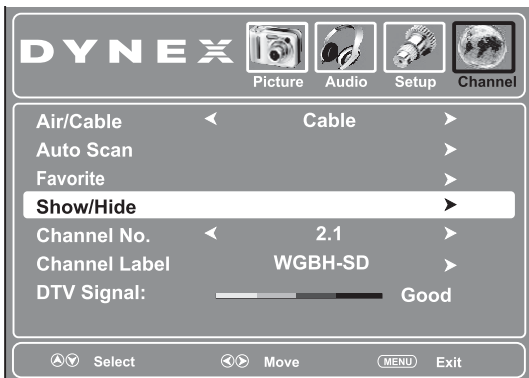

- 3 Press \blacktriangle or \blacktriangledown to highlight **Show/Hide**, then press **ENTER**. The channel list opens.

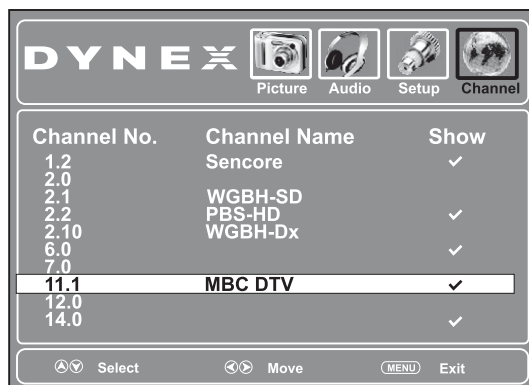

- 4 Press \blacktriangle or \blacktriangledown to highlight the channel you want to hide (the default is to show the channel), then press **ENTER** to remove the check mark from the channel.

Note: If the list has more than one page, press \leftarrow or \rightarrow to scroll through the pages.

- 5 Press **EXIT** to close the menu.

Setting up a favorite channel list

You can create a favorite channel list so you can quickly browse through your favorite channels by pressing **FAVORITE**, then selecting a channel from the favorite channel list.

To set up the favorite channel list:

- 1 Press **MENU**. The on-screen menu opens.

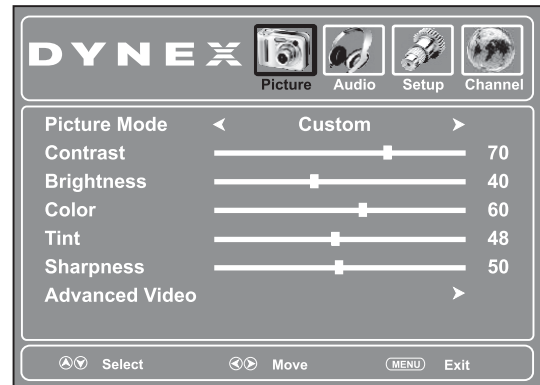

- 2 Press \leftarrow or \rightarrow to highlight **Channel**, then press ∇ . The *Channel* menu opens.

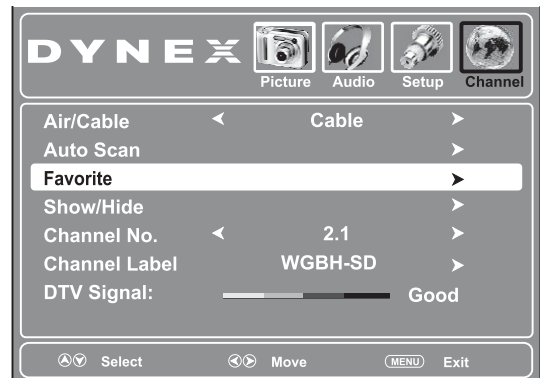

- 3 Select the signal source of the channel you want to set up on the favorites list.

- 4 Press \blacktriangle or \blacktriangledown to highlight **Favorite**, then press **ENTER**. The favorite channel list opens.

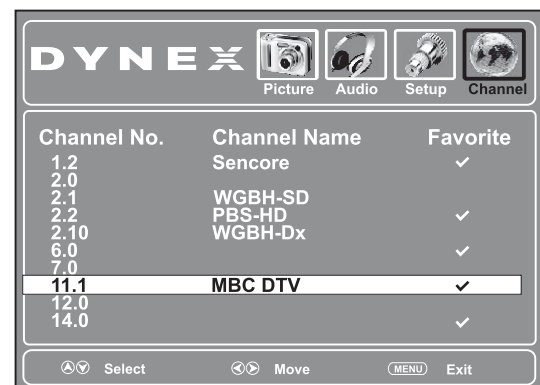

- 5 Press \blacktriangle or \blacktriangledown to highlight the channel you want to add to the favorite list, then press **ENTER** to mark the channel. A check mark appears if the channel is added to the list. The check mark disappears if you delete the channel from the list.

Note: If the list has more than one page, press \leftarrow or \rightarrow to scroll through the pages.

- 6 Press **EXIT** to close the menu.
- 7 To select a channel in the favorite channel list, press **FAVORITE**, press **▲** or **▼** to highlight the channel, then press **ENTER**.

- 7 Press **▲** or **▼** to select a character, then press **◀** or **▶** to move to the next position. Repeat this step to add more characters.
- 8 Press **MENU** to exit to the previous menu.

Adding or changing a channel label

Checking the DTV signal strength

If a channel is not already labeled, you can label the channel to make it easier to identify. You can also relabel a channel that is already labeled.

You can check the DTV signal strength to determine if you need to adjust your antenna or digital cable input. The higher the signal strength, the less likely you are to experience picture degradation.

To label a channel:

To check the DTV signal strength:

- 1 Press **MENU**. The on-screen menu opens.

- 1 Press **MENU**. The on-screen menu opens.

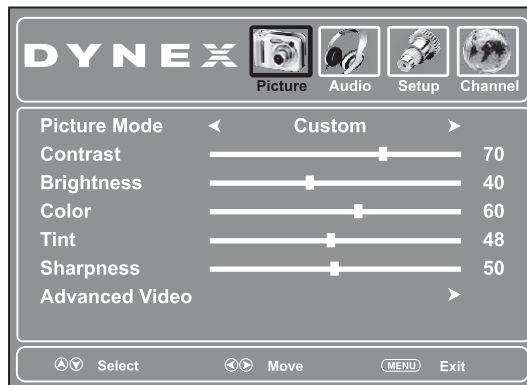
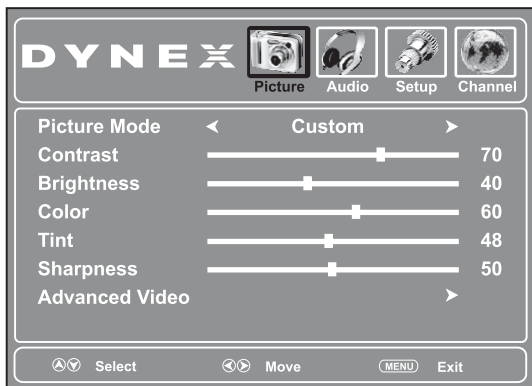

- 2 Press **◀** or **▶** to highlight **Channel**, then press **▼**. The *Channel* menu opens.

- 2 Press **◀** or **▶** to highlight **Channel**, then press **▼**. The *Channel* menu opens. The DTV signal strength is shown at the bottom of the menu.

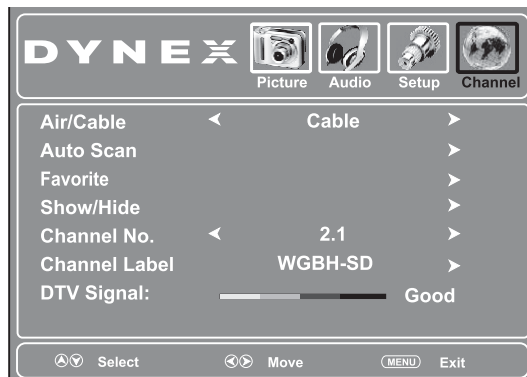
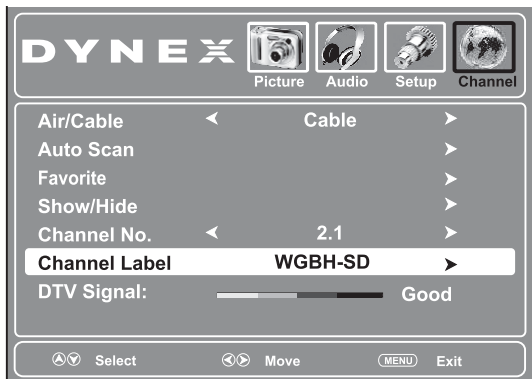

- 3 Select the signal source of the channel you want to label.
- 4 Highlight **Channel No.**, then press **◀** or **▶** to select the channel you want to label.
- 5 Press **▲** or **▼** to highlight **Channel Label**.
- 6 Press **ENTER** to open channel label screen. The *Channel Label* screen opens.

- 3 Press **EXIT** to close the menu.

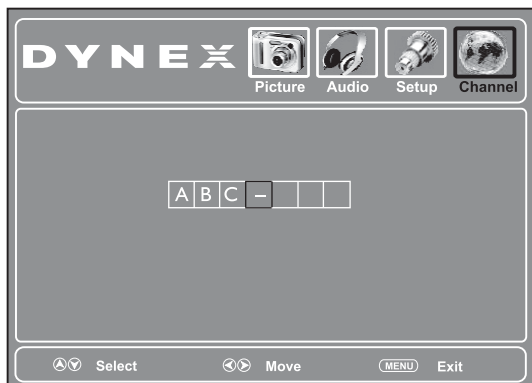

Setting parental controls

Parental controls let you prevent your children from watching inappropriate material on TV. When set, parental controls read the rating of the program (with some exceptions, such as news and sports) and deny access to programs that exceed the ratings level you select. To watch programs that exceed the selected rating, you must enter a password.

Turning parental controls on or off

To turn parental controls on or off:

- 1 Press **MENU**. The on-screen menu opens.

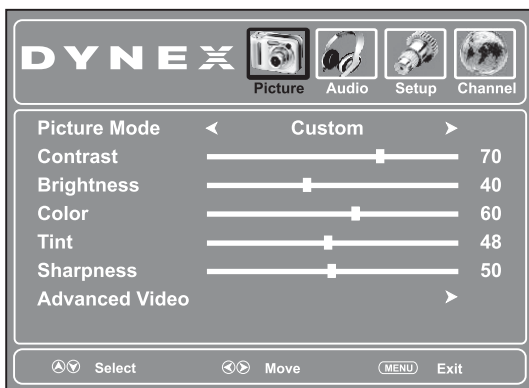

- 2 Press **◀** or **▶** to highlight **Setup**, then press **▼**. The *Setup* menu opens with **Parental Controls** selected.

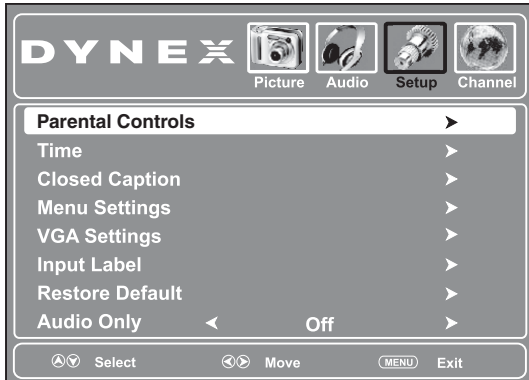

- 3 Press **ENTER**. The *Enter Password* screen opens.

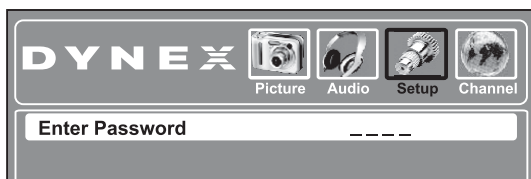

- 4 Press the number buttons to enter the four-digit password. The default password is **0000**. The Parental Controls sub menu opens.

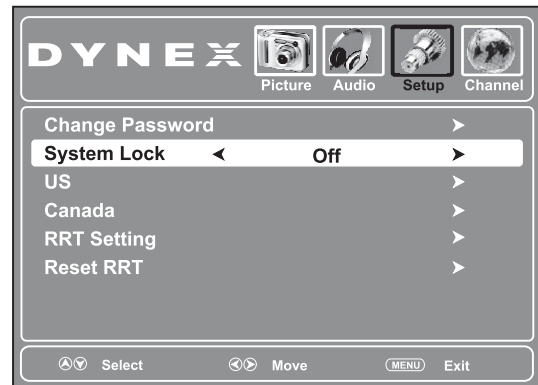

- 5 Press **▲** or **▼** to highlight **System Lock**, then press **◀** or **▶** to select **On** (to enable the blocking scheme you set up and to set up the blocking scheme (otherwise the rating setting can not be accessed) or **Off** (to disable the blocking scheme you set up).
- 6 Press **EXIT** to close the menu.

Setting or changing the password

To set the parental password:

- 1 Press **MENU**. The on-screen menu opens.

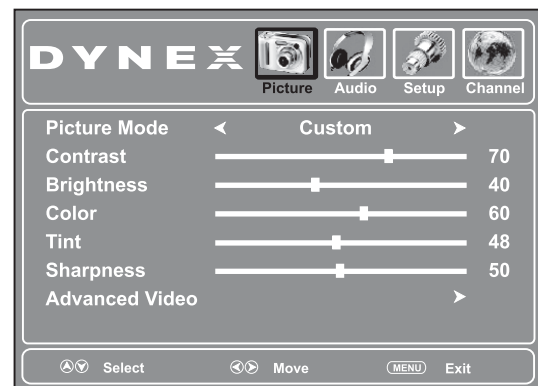

- 2 Press **◀** or **▶** to highlight **Setup**, then press **▼**. The *Setup* menu opens with **Parental Controls** selected.

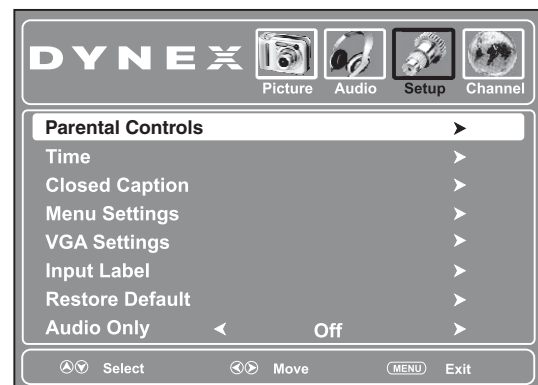

- 3 Press **ENTER**. The *Enter Password* screen opens.

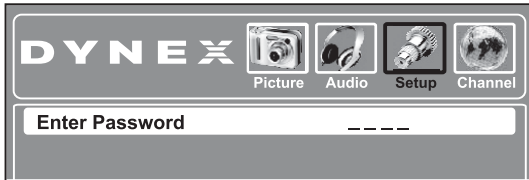

- 4 Press the number buttons to enter the four-digit password. The default password is **0000**. You should change the password to a number you can remember. The Parental Controls sub-menu opens.

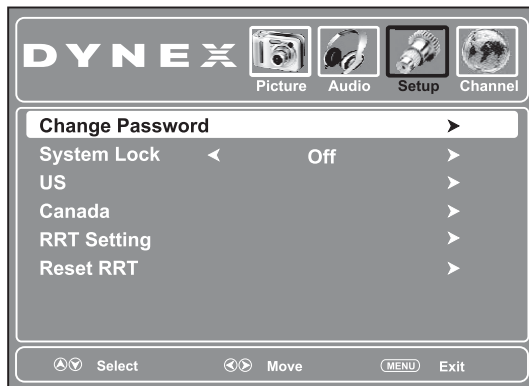

- 5 Press **▲** or **▼** to highlight **Change Password**, then press **ENTER**. The password entry screen opens.



- 6 Press the number buttons to input old password, then input a new password, and then confirm the new password again. The Parental Controls sub menu reopens.

Note: If you forget your password, enter **9999**.

- 7 Press **EXIT** to close the menu.

Setting parental control levels

You can set parental controls for the U.S. and Canada. The following procedure shows how to set controls for U.S. TV ratings. You use similar steps for controlling U.S. movie and Canadian TV ratings.

To set parental controls:

- 1 Press **MENU**. The on-screen menu opens.

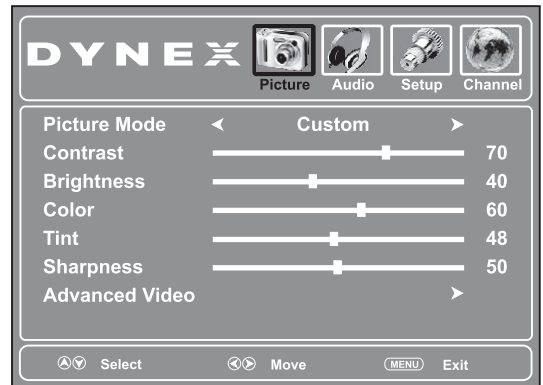

- 2 Press **◀** or **▶** to highlight **Setup**, then press **▼**. The *Setup* menu opens with **Parental Controls** selected.

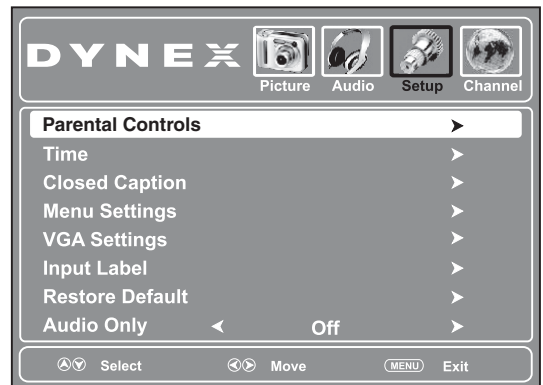

- 3 Press **ENTER**. The *Enter Password* screen opens.

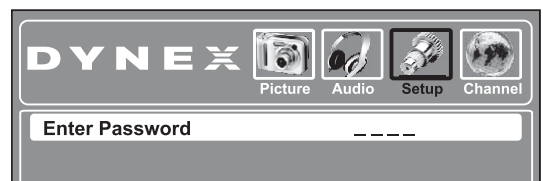

- 4 Press the number buttons to enter the four-digit password. The Parental Controls sub menu opens.

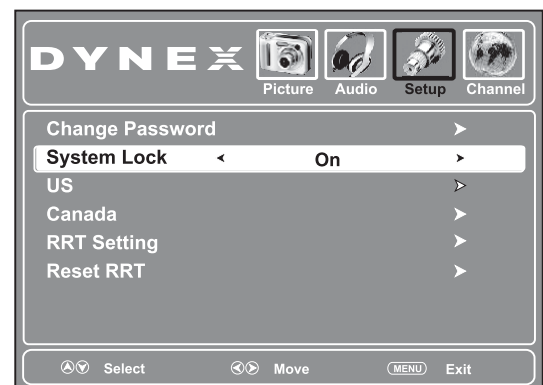

- 5 Press **▲** or **▼** to highlight **System Lock**, then press **◀** or **▶** to select **On**.

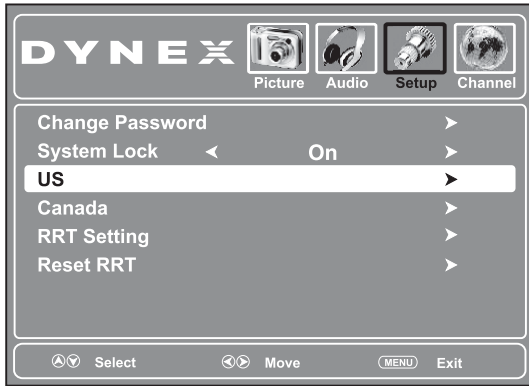

- 6 Press **▲** or **▼** to highlight **US**, then press **ENTER**. The **US settings** sub-menu opens.

Note: Select **Canada** to set Canadian TV controls.



- 7 Press **▲** or **▼** to highlight **TV**, then press **ENTER**. The **U.S. TV RATING** screen opens.

Note: Select **MPAA** to set controls for U.S. movie ratings.

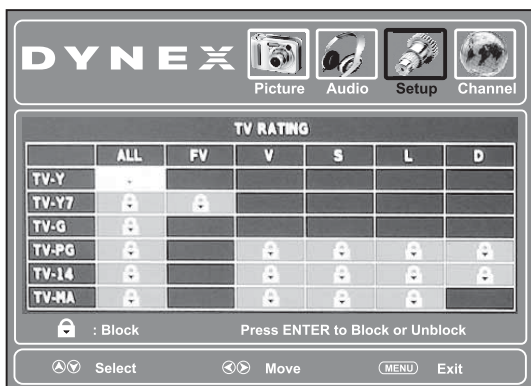

- 8 Press **▲** **▼** **◀** or **▶** to highlight the rating you want to block, then press **ENTER**. A lock symbol appears when a rating is blocked.

Note: On the MPAA Rating screen, press **▲** or **▼** to select the rating. That rating and all other higher ratings are blocked.

- 9 Press **EXIT** to close the menu.

U.S. TV ratings (age-based)

TV-Y	All children.
TV-Y7	Suitable for children 7 and older.
TV-G	General audiences.
TV-PG	Parental guidance suggested.
TV-14	Parental guidance strongly suggested.
TV-MA	Mature audiences only.

U. S. TV ratings (content-based)

FV	Fantasy violence.
V	Violence.
S	Sexual situations.
L	Strong language.
D	Suggestive dialog.

U.S. movie (MPAA) ratings

G	General audiences.
PG	Parental guidance suggested.
PG-13	Suitable for children 13 and older.
R	Parental guidance suggested for children under 17.
NC-17	Not suitable for children under 17.
X	Adults only.
N/A	Movie is not rated.

Canadian English ratings

EXEMPT	Exempt programming.
C	Suitable for all children.
C8+	Suitable for children 8 and older.
G	General audiences.
PG	Parental guidance suggested.
14+	Suitable for children 14 and older.
18+	Adults only.

Canadian French ratings

EXEMPT	Exempt programming.
G	General audiences.
8 ans+	Suitable for children 8 and older.
13 ans+	Suitable for children 13 and older.
16 ans+	Suitable for children 16 and older.
18 ans+	Adults only.

Downloading rating information

You can download rating information to use when setting parental controls.

To download rating information:

- 1 Press **MENU**. The on-screen menu opens.

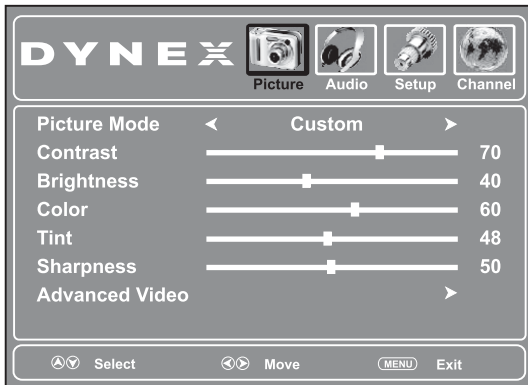

- 2 Press **◀** or **▶** to highlight **Setup**, then press **▼**. The *Setup* menu opens with **Parental Controls** selected.

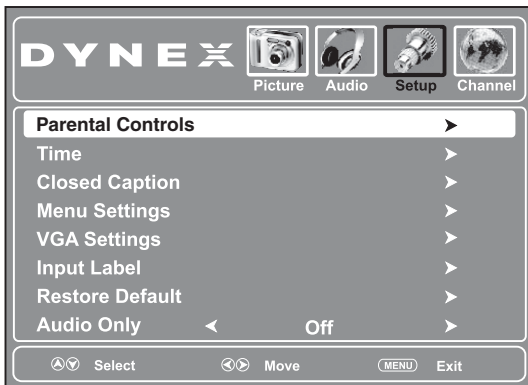

- 3 Press **ENTER**. The *Enter Password* screen opens.

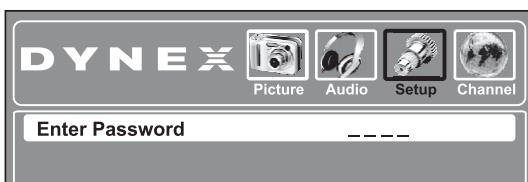

- 4 Press the number buttons to enter the four-digit password. The Parental Controls sub menu opens.

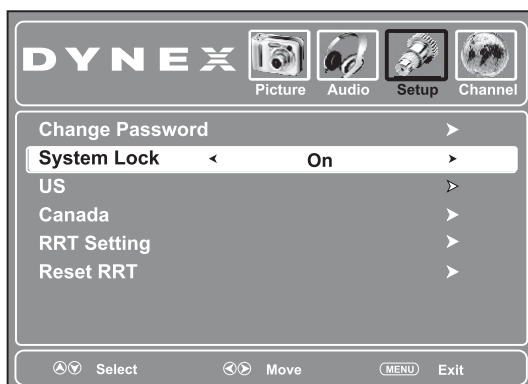

- 5 Press **▲** or **▼** to highlight **System Lock**, then press **◀** or **▶** to select **On**.

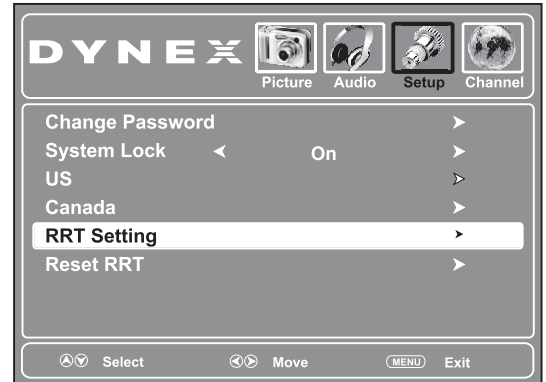

- 6 Press **▲** or **▼** to highlight **RRT Setting**, then press **ENTER**.

If the program is broadcast with RRT5 rating information, the information is downloaded automatically and can be used for parental controls.

Note: If you want to clear the downloaded rating information, select **Reset RRT**. The rating information is cleared. If rating information is broadcast by another program, your TV downloads the new rating information.

Using closed captioning

Turning closed captioning on or off

To turn closed captioning on or off:

- 1 Press **MENU**. The on-screen menu opens.

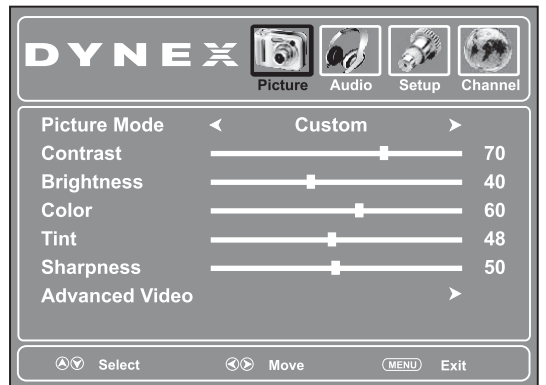

- 2 Press **◀** or **▶** to highlight **Setup**, then press **▼**. The *Setup* menu opens.



- 3 Press **▲** or **▼** to highlight **Closed Caption**, then press **▶** or **ENTER**. The closed caption menu opens.

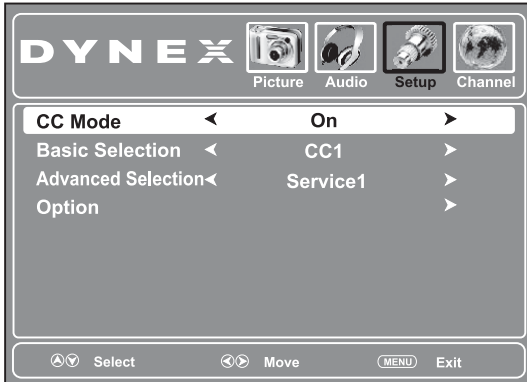

- 4 Press **▲** or **▼** to highlight **CC Mode**, then press **◀** or **▶** to select the CC mode. You can select **On** (turns on closed captioning), **CC on Mute** (turns on closed captioning when the sound is muted), or **Off** (turns off closed captioning).
- 5 Press **EXIT** to close the menu.

*Tip: You can also press **CCD** to turn closed captioning on or off.*

Selecting the closed captioning mode

To select the closed captioning mode:

- 1 Press **MENU**. The on-screen menu opens.

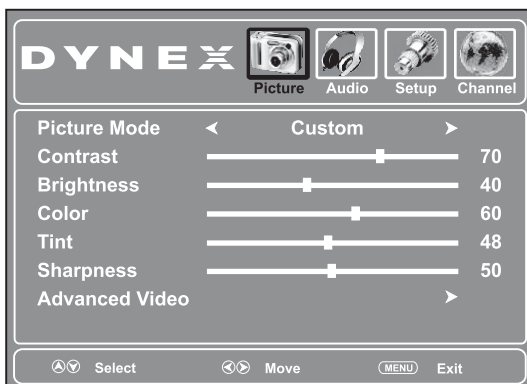

- 2 Press **◀** or **▶** to highlight **Setup**, then press **▼**. The *Setup* menu opens.



- 3 Press **▲** or **▼** to highlight **Closed Caption**, then press **▶** or **ENTER**. The closed caption menu opens.

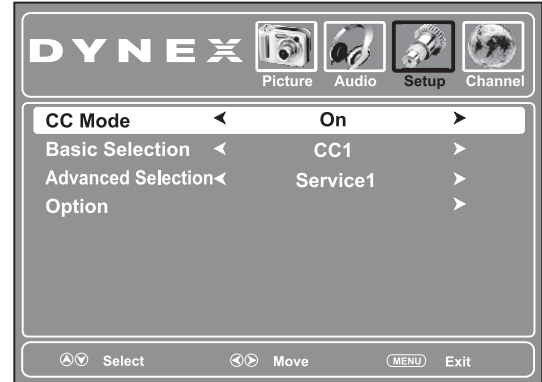

- 4 Press **▲** or **▼** to highlight **CC Mode**, then press **◀** or **▶** to select **On**.
- 5 Press **▲** or **▼** to highlight **Basic Selection**.

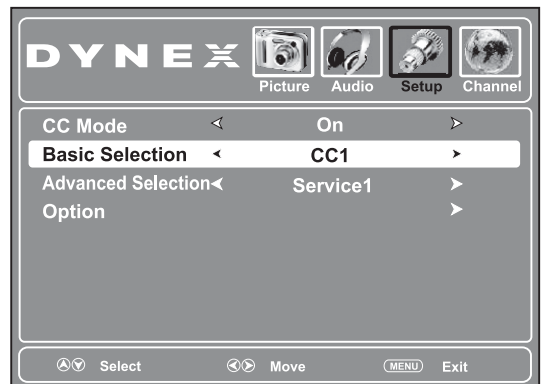

- 6 Press **◀** or **▶** to select a closed captioning mode. You can select:
- **CC1** through **CC4**—Closed captioning appears in a small banner across the bottom of the screen. **CC1** is usually the “printed” version of the audio. **CC2** through **CC4** display content provided by the broadcaster.
 - **Text1** through **Text4**—Closed captioning that covers half or all of the screen. **Text1** through **Text4** display content provided by the broadcaster.
- 7 Press **EXIT** to close the menu.

Customizing DTV closed captioning styles

You can customize the way DTV closed captioning is displayed.

To customize DTV closed captioning:

- 1 Press **MENU**. The on-screen menu opens.

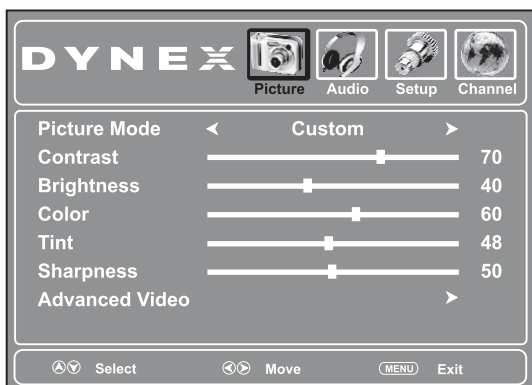

- 2 Press **◀** or **▶** to highlight **Setup**, then press **▼**. The *Setup* menu opens.

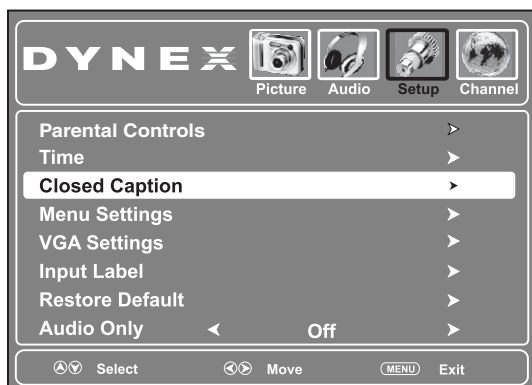

- 3 Press **▲** or **▼** to highlight **Closed Caption**, then press **▶** or **ENTER**. The closed caption menu opens.

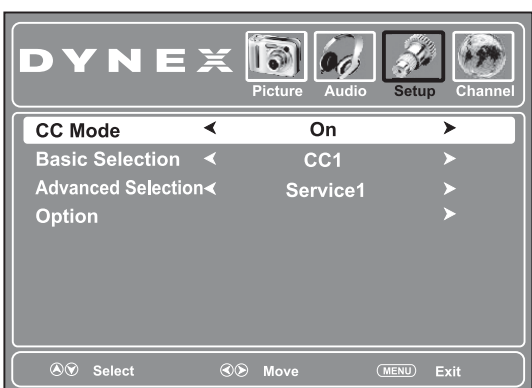

- 4 Press **▲** or **▼** to highlight **CC Mode**, then press **◀** or **▶** to select **On**.

- 5 Press **▲** or **▼** to highlight **Advanced Selection** (only available for digital stations).

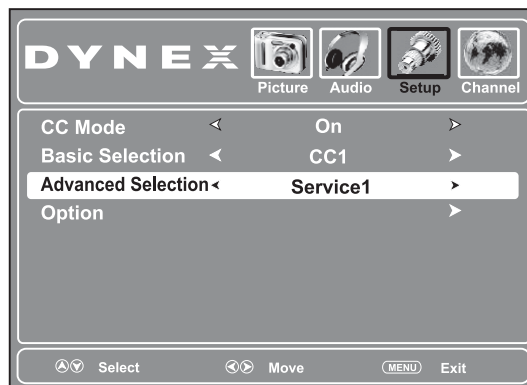

- 6 Press **◀** or **▶** to select an advanced digital closed captioning option. You can select **Service1** – **Service6** (displays content provided by the broadcaster).
- 7 Press **▲** or **▼** to highlight **Option**, then press **ENTER**. The DTV closed captioning styles menu opens.

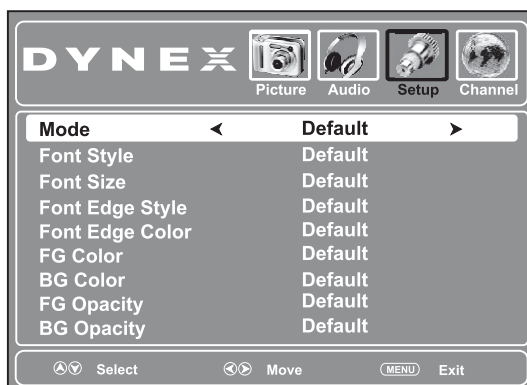

- 8 Press **▲** or **▼** to highlight **Mode**, then press **◀** or **▶** to select **Custom**.

Note: To reset the closed captioning styles to their defaults, set **Mode** to **Default**.

- 9 Press **▲** or **▼** to highlight a style, then press **◀** or **▶** to adjust the style. You can select:
 - **Font Style**—Selects the font style
 - **Font Size**—Selects the font size
 - **Font Edge Style**—Selects the edge style
 - **Font Edge Color**—Selects the edge color
 - **FG Color**—Selects the color for the words
 - **BG Color**—Selects the color for the background
 - **FG Opacity**—Selects the opacity level for the words
 - **BG Opacity**—Selects the opacity level for the background
- 10 Press **MENU** to return to the previous menu, or press **EXIT** to close the menu.

Adjusting time settings

Setting the clock

To set the clock:

- 1 Press **MENU**. The on-screen menu opens.

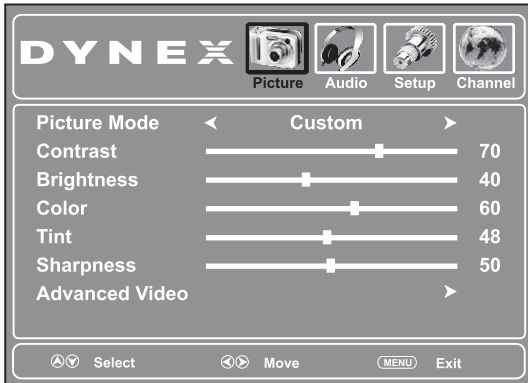

- 2 Press **◀** or **▶** to highlight **Setup**, then press **▼**. The *Setup* menu opens.

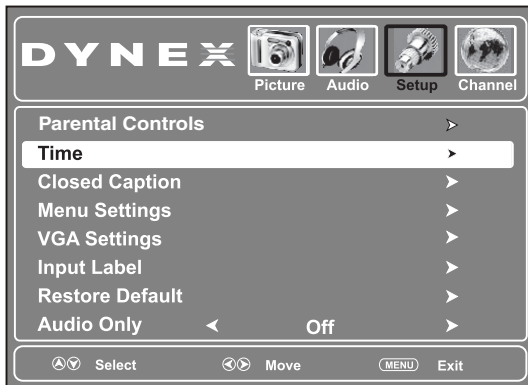

- 3 Press **▲** or **▼** to highlight **Time**, then press **ENTER**. The time setting menu opens.

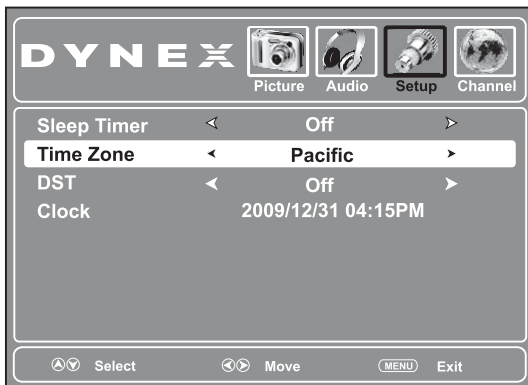

- 4 Press **▲** or **▼** to highlight **Time Zone**, then press **◀** or **▶** to select your time zone. You can select **Pacific**, **Alaska**, **Hawaii**, **Atlantic**, **Eastern**, **Central**, or **Mountain**.
- 5 If your viewing area observes Daylight Savings time, press **▲** or **▼** to highlight **DST**, then press **◀** or **▶** to select **On**.
The Clock row shows the current time, based on the time zone you select. This information is based on a digital channel and does not need to be set manually.
- 6 Press **EXIT** to close the menu.

Setting the sleep timer

You can specify the amount of time you want your TV to wait before it automatically turns off.

To set the sleep timer:

- 1 Press **MENU**. The on-screen menu opens.

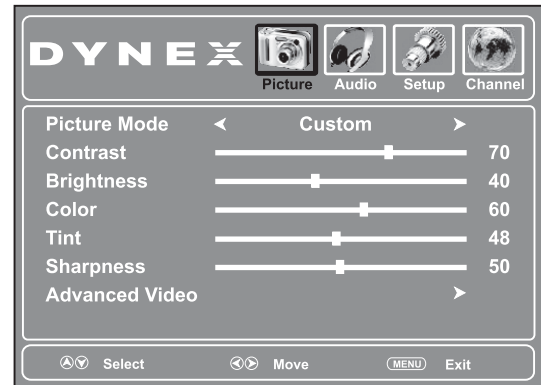

- 2 Press **◀** or **▶** to highlight **Setup**, then press **▼**. The *Setup* menu opens.



- 3 Press **▲** or **▼** to highlight **Time**, then press **ENTER**. The time setting menu opens.

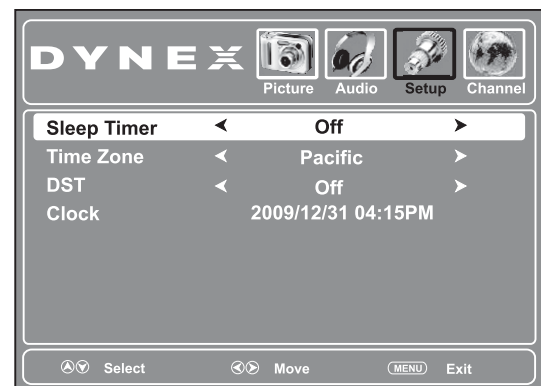

- 4 Press **▲** or **▼** to highlight **Sleep Timer**, then press **◀** or **▶** to select the amount of time you want your TV to wait before it automatically turns off.
Note: To turn off the sleep timer, select **Off**.
- 5 Press **EXIT** to close the menu.
Note: You can also press **SLEEP** on the remote control to set the sleep timer.

Adjusting menu settings

Selecting the menu language and transparency

To select the on-screen menu language and menu transparency:

- 1 Press **MENU**. The on-screen menu opens.

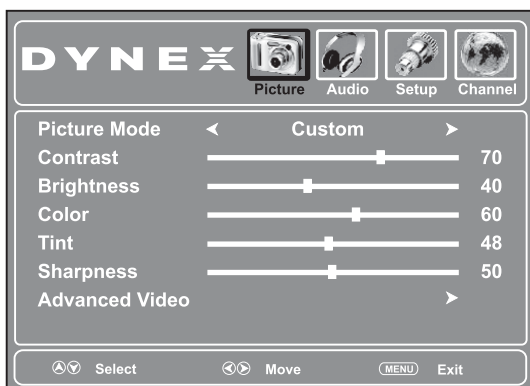

- 2 Press **◀** or **▶** to highlight **Setup**, then press **▼**. The *Setup* menu opens.

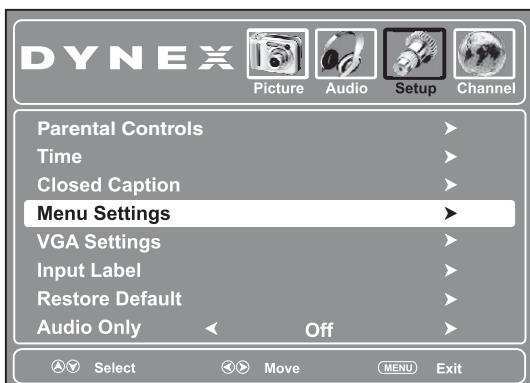

- 3 Press **▲** or **▼** to highlight **Menu Settings**, then press **ENTER**. The Menu Settings menu opens.

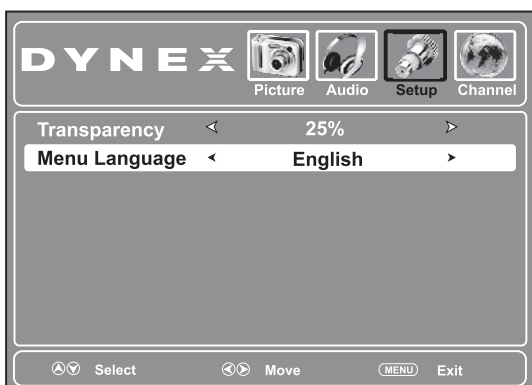

- 4 Press **▲** or **▼** to highlight **Menu Language**, then press **◀** or **▶** to select the menu language you want. Options include **English**, **French**, and **Spanish**.
- 5 Press **▲** or **▼** to select **Transparency**, then press **◀** or **▶** to select the menu transparency you want. Options include **0%**, **25%**, **50%**, **75%**, and **100%**
- 6 Press **EXIT** to close the menu.

Labeling an input source

You can add a label to an input source to make it easier to identify.

To label an input source:

- 1 Press **MENU**. The on-screen menu opens.

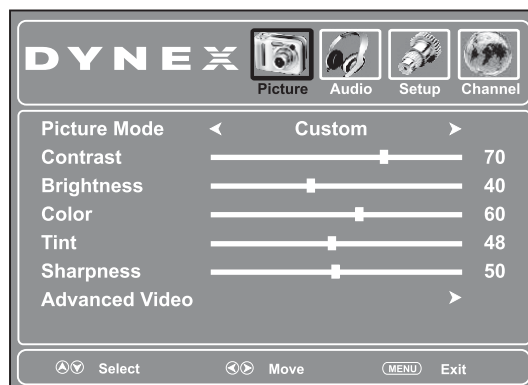

- 2 Press **◀** or **▶** to highlight **Setup**, then press **▼**. The *Setup* menu opens.

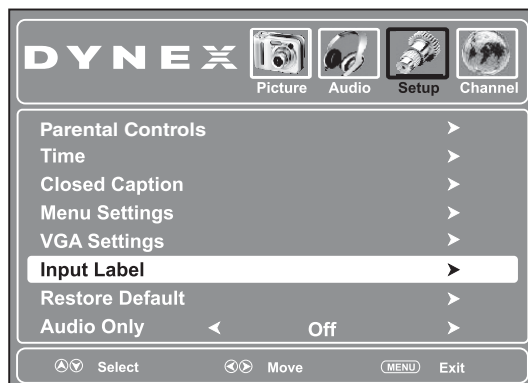

- 3 Press **▲** or **▼** to highlight **Input Label**, then press **ENTER**. The Input Label screen opens.

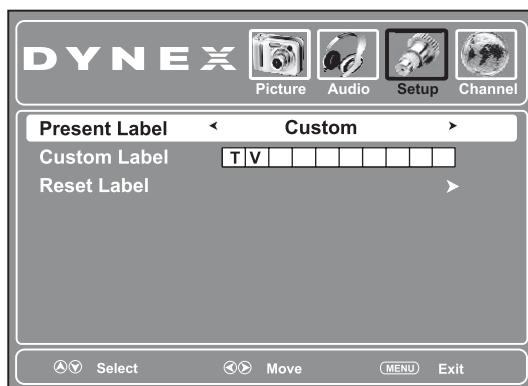

- 4 Press **◀** or **▶** to highlight a preset label from several options or select **Custom** to enter your own label.
- 5 If you select **Custom**, press **▲** or **▼** to highlight **Custom Label**, then press **▶**.
- 6 Press **▲** or **▼** to select a character, then press **◀** or **▶** to move to the next position. Repeat this step to add more characters.
- 7 To reset the label to the factory default, press **▲** or **▼** to highlight **Reset Label** and press **ENTER**, then follow the on-screen instructions.
- 8 Press **MENU** to exit.

Restoring default settings

Caution: When you restore default settings, all the settings (except the password and parental rating) you have customized are reset.

To restore default settings:

- 1 Press **MENU**. The on-screen menu opens.

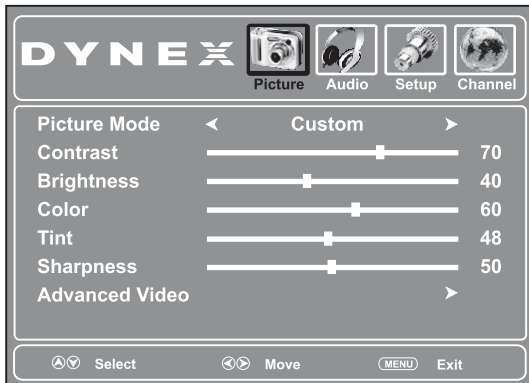

- 2 Press **◀** or **▶** to highlight **Setup**, then press **▼**. The *Setup* menu opens.

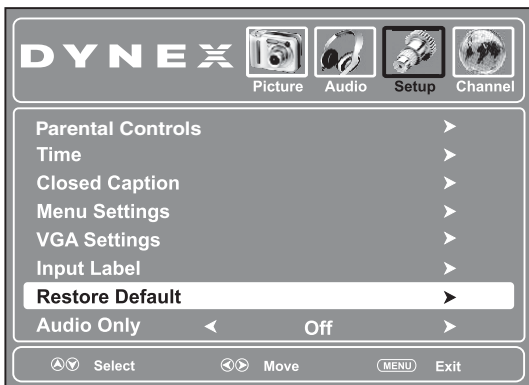

- 3 Press **▲** or **▼** to highlight **Restore Default**, then press **ENTER**. A confirmation box opens.
- 4 Press **◀** or **▶** to select **Yes**, then press **ENTER**.
- 5 Press **EXIT** to close the menu.

Troubleshooting

Before calling for service, check the following information for possible solutions to problems you may experience. If none of these solutions work, turn off the TV, then turn it on again.

Caution: Do not try to repair the TV yourself. Refer all servicing to qualified repair personnel.

Video and audio

Problem	Solution
No picture (screen is not lit) and no sound.	<ul style="list-style-type: none"> • Make sure that the power cord is plugged in. • Press POWER  on the TV or the remote control. • Make sure that the correct video input source is selected. For more information, see "Selecting the video input source" on page 14. • Try another channel. The station may be experiencing problems.
Dark, poor, or no picture (screen is lit), but sound is good.	<ul style="list-style-type: none"> • Adjust the brightness. For more information, see "Adjusting the TV picture" on page 16. • Make sure that the correct picture mode is selected. • Make sure that the antenna or cable TV is connected correctly and securely. For more information, see "Connecting an antenna, cable TV, or satellite TV box" on page 11.
No color, dark picture, or color is not correct.	<ul style="list-style-type: none"> • Adjust the color saturation. For more information, see "Adjusting the TV picture" on page 16.
Only snow (noise) appears on the screen.	<ul style="list-style-type: none"> • Try another channel. The station may be experiencing problems. • Make sure that the antenna or cable TV is connected correctly and securely. For more information, see "Connecting an antenna, cable TV, or satellite TV box" on page 11.
Dotted lines or stripes appear on the screen.	<ul style="list-style-type: none"> • Adjust the antenna. • Move the TV away from noise sources such as cars, neon signs, or hair dryers.
Double images.	<ul style="list-style-type: none"> • Use a highly directional outdoor antenna or cable TV.
Good picture, but no sound.	<ul style="list-style-type: none"> • Make sure that the sound is not muted. • Make sure that the sound mode is set to Stereo or Mono. For more information, see "Selecting the audio mode" on page 18.
Audio noise.	<ul style="list-style-type: none"> • Make sure that there is no interference with infrared equipment such as a cordless telephone or headphones. Move the infrared equipment away from the TV to eliminate the noise.

Remote control

Problem	Solution
Remote control does not work.	<ul style="list-style-type: none"> • Make sure that the power cord is plugged in. • Make sure that there are no obstructions between the remote control and the remote control sensor on the front of the TV. • Make sure that the batteries are installed correctly. For more information, see "Installing remote control batteries" on page 9. • Replace the batteries. For more information, see "Installing remote control batteries" on page 9.

General

Problem	Solution
One or more channels do not display.	<ul style="list-style-type: none"> • Make sure that the channels are not blocked. For more information, see "Setting parental control levels" on page 23. • Make sure that the channels are not hidden. For more information, see "Hiding channels" on page 20.
Password has been forgotten.	<ul style="list-style-type: none"> • Enter 9999 to access parental controls, then set a new password.
Some settings cannot be accessed.	<ul style="list-style-type: none"> • If a setting is grayed, the setting is not available in the current video input mode.
TV cabinet creaks.	<ul style="list-style-type: none"> • When the TV is in use, the temperature rises naturally and may cause the cabinet to expand or contract which can cause a creaking noise. This is not a malfunction.
Control buttons on the TV do not work.	<ul style="list-style-type: none"> • Disconnect the power cord, wait a few seconds, then reconnect the power cord and turn on the TV.

Maintenance

Cleaning

- Clean your TV with a soft, dry cloth. If surfaces are extremely dirty, use a soft cloth dampened with a weak detergent solution.
- Use an eyeglass cleaner to clean the screen. Never use alcohol, paint thinner, or benzine.
- Before using a chemically treated cloth, read the instructions that came with the cloth.

Specifications

Specifications subject to change without notice.
Weight and dimensions shown are approximate.

Type	LCD TV
Panel	26-inch TFT LCD
TV system	NTSC-M, ATSC
Receiving channels	VHF: 2 - 13 UHF: 14 - 69 CATV: 1 - 125 CADTV: 1 - 135 DTV: 2 - 69
Audio multiples	BTSC system
Audio out	5 W (2)
Power requirement	AC 120 V, 60 Hz
Power consumption	85 W
Dimensions (W × H × D with stand)	25.43 × 18.07 × 10.04 inches (64.6 × 45.9 × 25.5 cm)
Weight	20.94 lbs. (9.5 kg)
Input ports	Composite video/L and R audio (2) S-Video (1) Component video/L and R audio (1) HDMI (2) VGA/audio (1) Antenna (1)
Output ports	Audio L and R (1) Headphone (1)
Control ports	Service port (1) RS-232 (1)

Legal notices

FCC Part 15

This device complies with Part 15 of the FCC Rules. Operation of this product is subject to the following two conditions: (1) this device may not cause harmful interference, and (2) this device must accept any interference received, including interference that may cause undesired operation.

This equipment has been tested and found to comply within the limits for a class B digital device, pursuant to Part 15 of the FCC Rules. These limits are designed to provide reasonable protection against harmful interference in a residential installation. This equipment generates, uses, and can radiate radio frequency energy and, if not installed and used in accordance with the instructions, may cause harmful interference to radio communications. However, there is no guarantee that interference will not occur in a particular installation. If this equipment does cause harmful interference to radio or television reception, which can be determined by turning the equipment off and on, the user is encouraged to try to correct the interference by one or more of the following measures:

- Reorient or relocate the receiving antenna.
- Increase the separation between the equipment and receiver.
- Connect the equipment into an outlet on a circuit different from that to which the receiver is connected.
- Consult the dealer or an experienced technician for help.

FCC warning

Changes or modifications not expressly approved by the party responsible for compliance with the FCC Rules could void the user's authority to operate this equipment.

Canada ICES-003 statement

This Class B digital apparatus complies with Canadian ICES-003.

ICES/BETS-7 Statements

Standard Television Receiving Apparatus — Appareil de réception télévision ordinaire, Canada BETS-7 / NTMR-7

Notices

Specifications and features are subject to change without notice or obligation.

For service and support call (800) 305-2204.

One-year limited warranty

Dynex Products ("Dynex") warrants to you, the original purchaser of this new **DX-L26-10A** ("Product"), that the Product shall be free of defects in the original manufacture of the material or workmanship for a period of one (1) year from the date of your purchase of the Product ("Warranty Period"). This Product must be purchased from an authorized dealer of Dynex brand Products and packaged with this warranty statement. This warranty does not cover refurbished product. If you notify Dynex during the Warranty Period of a defect covered by this warranty that requires service, terms of this warranty apply.

How long does the coverage last?

The Warranty Period lasts for one year (365 days) from the date you purchased the Product. The purchase date is printed on the receipt you received with the Product.

What does this warranty cover?

During the Warranty Period, if the original manufacture of the material or workmanship of the Product is determined to be defective by an authorized Dynex repair center or store personnel, Dynex will (at its sole option): (1) repair the Product with new or rebuilt parts; or (2) replace the Product at no charge with new or rebuilt comparable products or parts. Products and parts replaced under this warranty become the property of Dynex and are not returned to you. If service of products and parts are required after the Warranty Period expires, you must pay all labor and parts charges. This warranty lasts as long as you own your Dynex Product during the Warranty Period. Warranty coverage terminates if you sell or otherwise transfer the Product.

How to obtain warranty service?

If you purchased the Product at a retail store location, take your original receipt and the Product to the store you purchased it from. Make sure that you place the Product in its original packaging or packaging that provides the same amount of protection as the original packaging. If you purchased the Product from an online web site, mail your original receipt and the Product to the address listed on the web site. Make sure that you put the Product in its original packaging or packaging that provides the same amount of protection as the original packaging.

To obtain in-home warranty service for a television with a screen 30 inches or larger, call 1-888-BESTBUY. Call agents will diagnose and correct the issue over the phone or will have an Dynex-approved repair person dispatched to your home.

Where is the warranty valid?

This warranty is valid only to the original purchaser of the Product in the United States, Canada, and Mexico.

What does the warranty not cover?

This warranty does not cover:

- Customer instruction
- Installation
- Set up adjustments
- Cosmetic damage
- Damage due to acts of God, such as lightning strikes
- Accident
- Misuse
- Abuse
- Negligence
- Commercial use
- Modification of any part of the Product
- Plasma display panel damaged by static (non-moving) images applied for lengthy periods (burn-in).

This warranty also does not cover:

- Damage due to incorrect operation or maintenance
- Connection to an incorrect voltage supply
- Attempted repair by anyone other than a facility authorized by Dynex to service the Product
- Products sold as is or with all faults
- Consumables, such as fuses or batteries
- Products where the factory applied serial number has been altered or removed

REPAIR REPLACEMENT AS PROVIDED UNDER THIS WARRANTY IS YOUR EXCLUSIVE REMEDY. DYNEX SHALL NOT BE LIABLE FOR ANY INCIDENTAL OR CONSEQUENTIAL DAMAGES FOR THE BREACH OF ANY EXPRESS OR IMPLIED WARRANTY ON THIS PRODUCT, INCLUDING, BUT NOT LIMITED TO, LOST DATA, LOSS OF USE OF YOUR PRODUCT, LOST BUSINESS OR LOST PROFITS. DYNEX PRODUCTS MAKES NO OTHER EXPRESS WARRANTIES WITH RESPECT TO THE PRODUCT, ALL EXPRESS AND IMPLIED WARRANTIES FOR THE PRODUCT, INCLUDING, BUT NOT LIMITED TO, ANY IMPLIED WARRANTIES OF AND CONDITIONS OF MERCHANTABILITY AND FITNESS FOR A PARTICULAR PURPOSE, ARE LIMITED IN DURATION TO THE WARRANTY PERIOD SET FORTH ABOVE AND NO WARRANTIES, WHETHER EXPRESS OR IMPLIED, WILL APPLY AFTER THE WARRANTY PERIOD. SOME STATES, PROVINCES AND JURISDICTIONS DO NOT ALLOW LIMITATIONS ON HOW LONG AN IMPLIED WARRANTY LASTS, SO THE ABOVE LIMITATION MAY NOT APPLY TO YOU. THIS WARRANTY GIVES YOU SPECIFIC LEGAL RIGHTS, AND YOU MAY ALSO HAVE OTHER RIGHTS, WHICH VARY FROM STATE TO STATE OR PROVINCE TO PROVINCE.

Contact Dynex:

For customer service please call 1-800-305-2204

www.dynexproducts.com

Distributed by Best Buy Purchasing, LLC

7601 Penn Avenue South, Richfield, Minnesota, U.S.A. 55423-3645

© 2009 Best Buy Enterprise Services, Inc.

All rights reserved. DYNEX is a trademark of Best Buy Enterprise Services, Inc. Registered in some countries. All other products and brand names are trademarks of their respective owners.

DYNEX™

www.dynexproducts.com (800) 305-2204

Distributed by Best Buy Purchasing, LLC
7601 Penn Ave. South, Richfield, MN 55423 U.S.A.

© 2009 Best Buy Enterprise Services, Inc. All rights reserved.

DYNEX is a trademark of Best Buy Enterprise Services, Inc. Registered in some countries. All other products and brand names are trademarks of their respective owners.

08-1835
ENGLISH