

dyson ball

DC
24

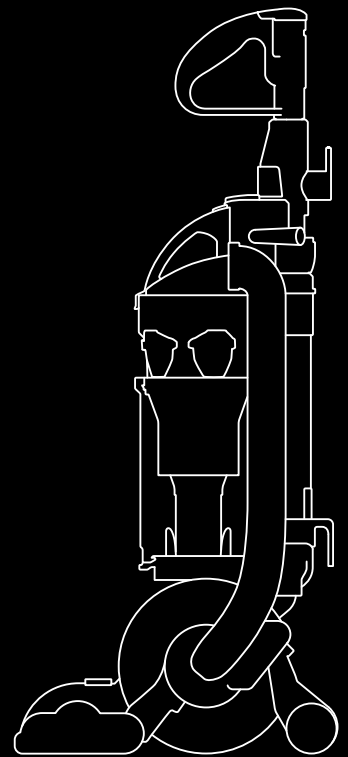

5 year guarantee

Parts and labour guaranteed by Dyson for 5 years.

Ensure you register for your 5 year guarantee today.



ONLINE

Just visit

www.dyson.com/register



PHONE

7 days a week

UK 0800 279 5127
IRL 01 475 7109



MAIL

Complete and return the free post registration form

After registering for your 5 year guarantee, your Dyson vacuum cleaner will be covered for parts and labour for 5 years from the date of purchase, subject to the terms of the guarantee.

If you have any query about your Dyson, call the Dyson Customer Helpline with your serial number and details of where/when you bought the cleaner. Your serial number can be found on your rating plate which is behind the clear bin™.

Most queries can be solved over the phone by one of our trained Helpline staff. If your machine needs attention, we'll aim to send one of our Dyson engineers to fix it within 3 working days. We won't keep you waiting around either; our engineers can visit a home or work address – wherever is most convenient for you.



Note your serial number for future reference

⚠ GENERAL SAFETY PRECAUTIONS ⚠

READ ALL INSTRUCTIONS BEFORE USING THIS VACUUM CLEANER

When using an electrical appliance, basic precautions should always be followed, including the following:

- 1 This machine is for domestic use only. **Do not** use outdoors or on wet surfaces.
- 2 **Do not** handle plug or appliance with wet hands.
- 3 **Do not** use with damaged cable or plug. If the supply cable is damaged, it must be replaced by Dyson Ltd, our service agent or similarly qualified persons in order to avoid a hazard.
- 4 If the vacuum cleaner is not functioning properly, has been dropped, damaged, left outdoors, or immersed in liquid, **do not** use. Contact the Dyson Helpline.
- 5 **Do not** use the cleaner if any parts appear to be faulty, missing or damaged.
- 6 Ensure all parts including clear bin™ are securely attached before use or carrying the machine.
- 7 This appliance is not intended for use by persons (including children) with reduced physical, sensory or mental capabilities, or lack of experience and knowledge, unless they have been given supervision or instruction concerning use of the appliance by a person responsible for their safety. Children should be supervised to ensure that they do not play with the appliance.
- 8 **Do not** leave appliance when plugged in. Unplug from outlet when not in use, and before performing user maintenance, connecting or disconnecting the hose or changing accessories.
- 9 If the machine overheats it will cut-out. If that happens, it must be switched off, unplugged and allowed to cool down before attempting to check filters or for blockages.
- 10 Store the machine indoors. Put the vacuum cleaner away after use with the cable coiled safely, to prevent tripping hazards.
- 11 Turn off all controls before unplugging.
- 12 **Do not** unplug by pulling on cable. To unplug, grasp the plug, not the cable.
- 13 **Do not** pull or carry by cable, use cable as a handle, close a door on cable, or pull cable around sharp edges or corners. **Do not** run appliance over cable. Keep cable away from heated surfaces.
- 14 The use of an extension cable is not recommended.
- 15 Keep hair, loose clothing, fingers, and all parts of body away from openings and moving parts, such as the brushbar.
- 16 **Do not** put any object into openings. **Do not** use with any opening blocked.
- 17 Take extra care when vacuuming on stairs; **do not** work with the vacuum cleaner above you on the stairs.
- 18 Keep the vacuum cleaner on the floor. **Do not** put the vacuum cleaner on chairs, tables etc.
- 19 **Do not** shake the machine or press cyclone release button while carrying the machine.
- 20 **Do not** use to pick up flammable or combustible liquids, such as petrol, or use in areas where they may be present.
- 21 **Do not** pick up anything that is burning or smoking, such as cigarettes, matches, or hot ashes.
- 22 Check to ensure your electricity supply corresponds to that shown on the rating plate. The vacuum cleaner must only be used as rated.
- 23 Use only as described in this manual. Use only Dyson recommended attachments.
- 24 **Do not** use without clear bin™ and filters in place.
- 25 **Do not** lubricate any parts, or carry out any maintenance or repair work other than that shown in this manual, or as advised by the Dyson Helpline.



Do not pull on the cable.



Do not store near heat sources.



Do not use near naked flame.



Do not run over the cable.



Do not pick up water or liquids.



Do not pick up burning objects.



Do not use above you on the stairs.



Do not put hands near the brushbar when the cleaner is in use.

Using your Dyson

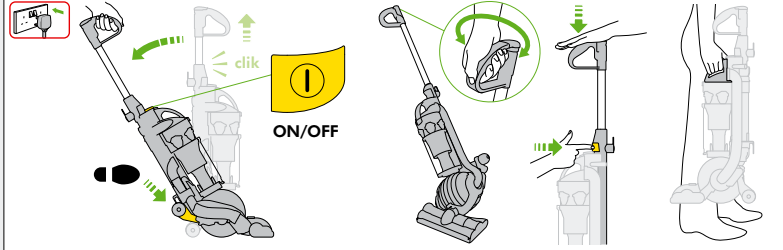

Hard floors or carpets

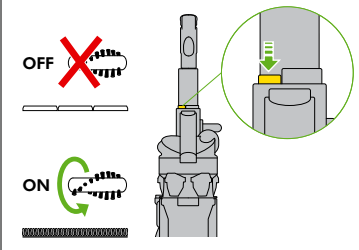

High-reach cleaning

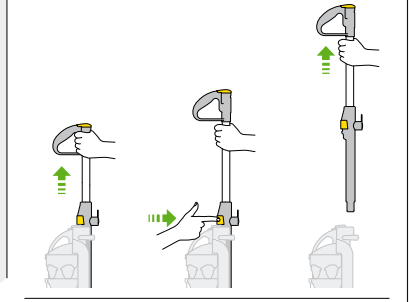

Clear bin™ emptying

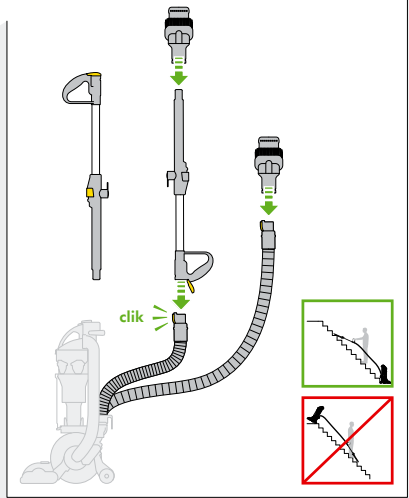
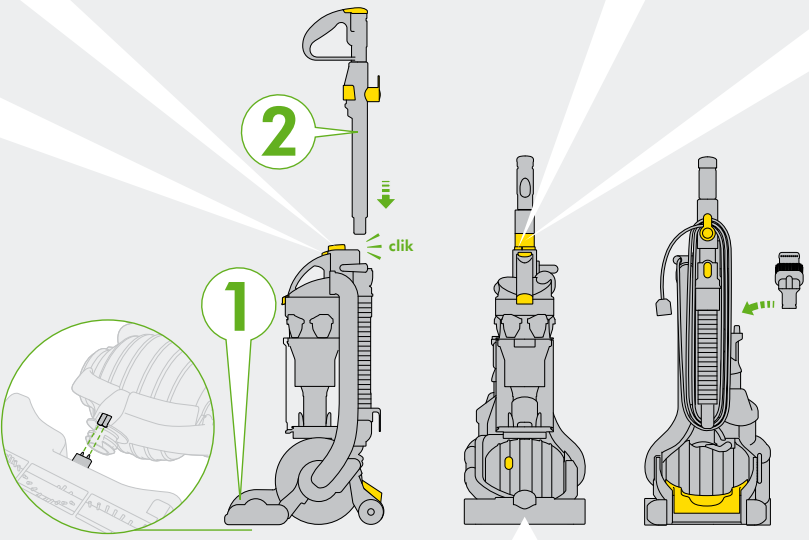
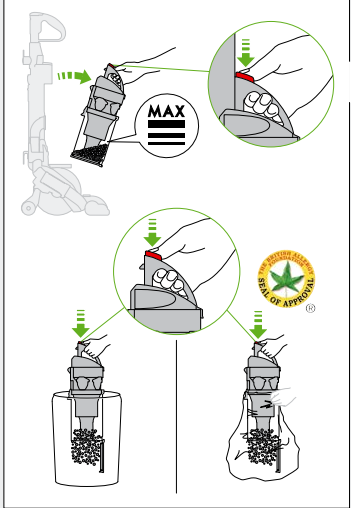

Looking for blockages

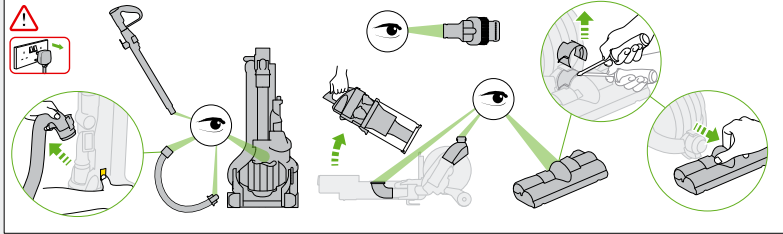

Clearing brushbar obstructions

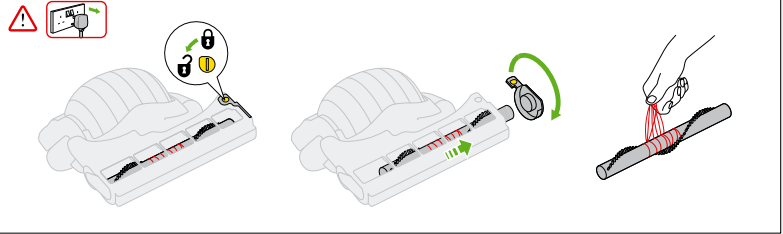

IMPORTANT! WASH FILTERS



Wash filters with cold water at least every month.

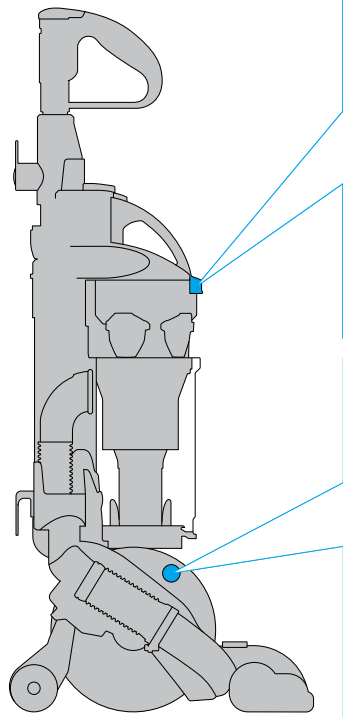

Filter A

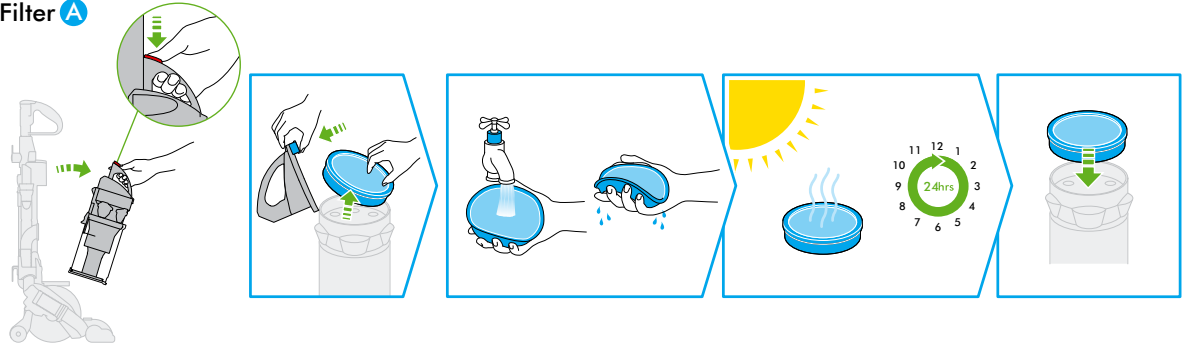

Filter B

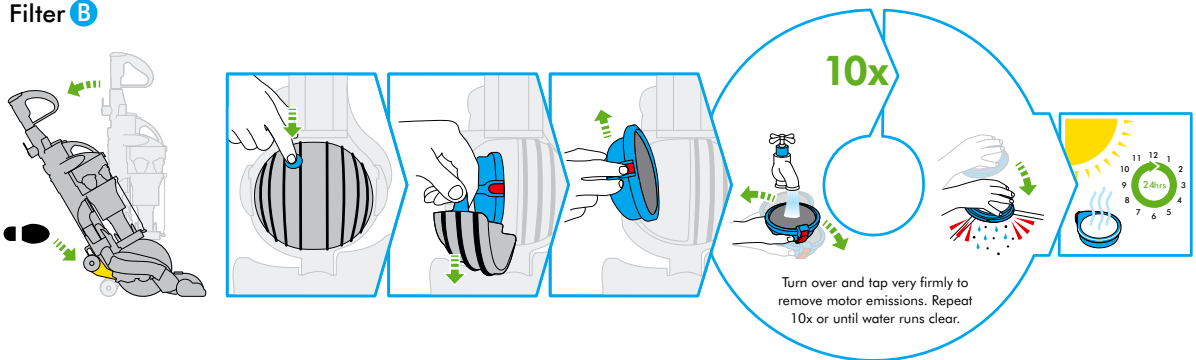

Turn over and tap very firmly to remove motor emissions. Repeat 10x or until water runs clear.



Assembly

Lie machine flat and push on cleaner head until it clicks. Stand vacuum up straight, insert wand into hose and push into place until it clicks. Attach tool to the side of the machine.

Using your Dyson

Press foot pedal and recline handle to use. The stabiliser stand will automatically lift up. To switch 'ON', depress power button in front of handle. When finished cleaning, push machine into an upright position and stabiliser wheels will automatically drop. Use the carrying handle to carry the machine.

Caution:



- (i) When returning to the upright position, ensure that the stabiliser wheels are fully engaged before releasing the cleaner.
- (ii) **Do not** press the cyclone release button while carrying the machine or it could fall and cause injury.

Please note:

- (i) Fine dust such as plaster or flour should only be vacuumed in very small amounts.
- (ii) Consult your flooring manufacturer's recommended instructions before vacuuming and caring for your flooring, rugs and carpets. Some carpets will fuzz if a rotating brushbar is used when vacuuming. If this is the case, we recommend vacuuming in hard floors mode and consulting with your flooring manufacturer. (See 'Hard floors or carpets' section.)
- (iii) If used in a garage for car cleaning, care should be taken to wipe the soleplate and wheels with a dry cloth after vacuuming to clean off any sand, dirt, or pebbles which could damage delicate floors.

Hard floors or carpets

The brushbar will always default to 'ON' (spinning) each time you switch on the machine and recline it for cleaning. The brushbar will automatically stop if it becomes obstructed. If the brushbar stops during use, please refer to the 'Clearing brushbar obstructions' section.

To switch the brushbar off (e.g. for hard floors), recline the machine and turn it 'ON', then press the brushbar 'ON/OFF' button – the brushbar will stop spinning.

High-reach cleaning

Caution:



- (i) Powerful suction can cause the hose to 'pull back' – please take care.
- (ii) To avoid personal injury and to prevent the machine from falling when cleaning stairs, **do not** work with the vacuum above you on the stairs.

To release the wand, press button and lift up. Rotate the wand, open the wand cap and clip handle into hose. Tools can be attached to either the hose or wand.

Emptying the Clear bin™

Caution:



- (i) Switch 'OFF' machine before emptying the bin.

Empty as soon as the dirt reaches the level of the MAX mark – do not overfill. To remove the clear bin™ from the machine press the button at rear of carrying handle. To release the dirt, press the button again to open the bin. The British Allergy Foundation is a UK national charity with the aim of improving awareness, prevention and treatment of allergies. The British Allergy Foundation Seal of Approval is a UK-registered trademark.

Please note:

- (i) **Do not** use the machine without the clear bin™ in place.

Cleaning the Clear bin™

Caution:



- (i) **Do not** immerse the whole cyclone in water or pour water into the cyclones.
- (ii) Ensure bin is completely dry before replacing.

Please note:

- (i) **Do not** use detergents, polishes or air fresheners to clean the bin.
- (ii) **Do not** put bin in a dishwasher.
- (iii) When vacuuming, certain carpets may generate small static charges in the clear bin™. These are entirely harmless and are not associated with the mains supply. To minimise any effect from this, **do not** put your hand or insert any object into the clear bin™ unless you have first emptied it and rinsed it out with cold water.

Washing your filters

Caution:



- (i) Switch 'OFF' before removing the filters.
- (ii) Ensure filters are completely dry before refitting to machine.

This machine has two filters, located as shown. It is important to check your filters regularly and wash at least **every month** according to instructions, to maintain performance. The filter in the ball should be rinsed and tapped out until the water runs clean, then tapped out again to ensure all excess water is removed. This will normally require up to 10 rinse cycles. Please leave to dry completely for 24 hours.

Please note:

- (i) It is normal for the filter in the ball to turn grey in colour. The filters may require more frequent washing if vacuuming fine dust.
- (ii) **Do not** use detergents to clean the filters.
- (iii) **Do not** put the filters in the dishwasher, washing machine, tumble dryer, oven, microwave or near an open flame.

Looking for blockages

Caution:



- (i) Switch 'OFF' and unplug machine before checking for blockages.
- (ii) Please ensure machine is upright before removing hose or airway inspection parts.
- (iii) Beware of sharp objects when clearing blockages.
- (iv) Refit all parts of the machine securely before using.

Please note:

- (i) Clearing blockages is not covered by your machine's limited warranty. If any part of your machine becomes blocked, it may overheat and then automatically shut off. Unplug machine and leave to cool down. Clear blockage before restarting.

Clearing brushbar obstructions

Caution:



- (i) Switch 'OFF' and unplug machine before clearing brushbar obstructions. If your brushbar is obstructed, it may shut off. If this happens you will need to remove brushbar as shown and clear any obstructing debris.

Conformity information: A sample of this product has been tested and found to conform with the following European Directives: 2006/95/EC Low voltage Directive, 2004/108/EC EMC Directive, 93/68/EEC CE Marking Directive.

Product information: Net weight 5.2kg, 230-240V, 50Hz, maximum power 650W.
This product is protected by the following intellectual property rights:

Patent/Patent Application numbers: JP 2004-537336; EP 1361812; AU 744408; EP1119282; JP 2002-527132; US 6,519,807; AU 744362; EP 1121043; JP 2002-527131; US 6,572,078; GB 0326102.1; AU 2002-226556; EP 1370172; JP 2004-528876; US 6,991,666; AU 2002-225207; EP 1361814; JP 2004-520137; US 7,018,439; AU 2001-240894; EP 1268076; JP 2003-528704; US 6,835,222; AU 2002-225232; EP 1361815; JP 3940082; US 6,974,488; AU 2003-283157; EP 1526796; JP 2006-503607; US 2005-0235454; AU 2003-283159; EP 1526797; JP 2005-534442; AU 2003-283161; EP 1526798; JP 2006-503608; AU 2004-294771; EP 1680232; JP 2007-508934; US 2007-0079579; AU 2005-263889; EP 1768536

Equivalent patents, registered designs and applications exist in other countries.

Please note: Small details may vary from those shown.

IMPORTANT!

WASH FILTERS



Wash filters with cold water at least every month.



GB Dyson Customer care
service@dyson.co.uk
0800 279 5127
Dyson Ltd, Tetbury Hill, Malmesbury, Wiltshire SN16 0RP

IRL Dyson Customer care
irelandservice@dyson.com
01 475 7109
The Connect Agency Ltd, Unit 2, Baldonnell Business Park,
Naas Road, Co. Dublin.

Dyson Customer care

If you have a question about your Dyson vacuum cleaner, call the Dyson Helpline with your serial number and details of where and when you bought the cleaner, or contact us via the Dyson website. The serial number can be found on the main body of the machine behind the clear bin.[™]