

bēm[®]
WIRELESS

USER GUIDE

Contents

english 3

Product Overview

Thanks for purchasing the bēm wireless EXO-400! This speaker is Bluetooth ready, easy to use, and able to hit the trail - rain or shine - making it ideal for listening to music on a hike, at home, or anywhere in-between. But to make sure you get the best possible results from your new EXO-400 Bluetooth speaker, please thoroughly read and carefully follow all instructions in this User Guide. This short guide explains everything you need to know to start using your speaker.

Please keep this User Guide in a convenient location for future reference and visit bemwireless.com for additional information.

Product Overview (cont)

The bēm wireless EXO-400 combines great sound with Bluetooth connectivity. With a rugged design and a built-in climbing hook, hands-free use on the go is easy! Simply pair your EXO-400 with your Bluetooth enabled device and enjoy wireless performance wherever you are.

Package Contents

Your EXO-400 should include:

EXO-400 Water Resistant Speaker x 1

Auxiliary (AUX) Cable x 1

Micro USB Charging Cable x 1

USB AC Adaptor x 1

USB Car Adaptor x 1

Carabineer x 1

User Guide x 1

If any items are missing or damaged, please call bēm wireless customer support at 1-855-839-8616 or email admin@bemwireless.com to arrange for replacements.



Durability

V1

Trail-ready, life-ready, you ready. The EXO-400 is the perfect combination of good looks and durability. With an IP7 rating for dust resistance and water immersion for up to one minute, it can handle almost anything you throw at. Just clip it to your pack with the built in climbing clip and live life without worrying about your music.

V2



Trail-ready, life-ready, you ready. The EXO-400 is the perfect combination of good looks and durability. Just clip it to your pack and live life without worrying about your music.



-IP7 rated

-Dust resistant and waterproof (immersion up to one minute)

-Built in climbing clip

Compatibility

All devices enabled with Bluetooth technology, including iPhones, iPads, iPods, smartphones, laptops, tablets and more.

Meet Your New EXO-400

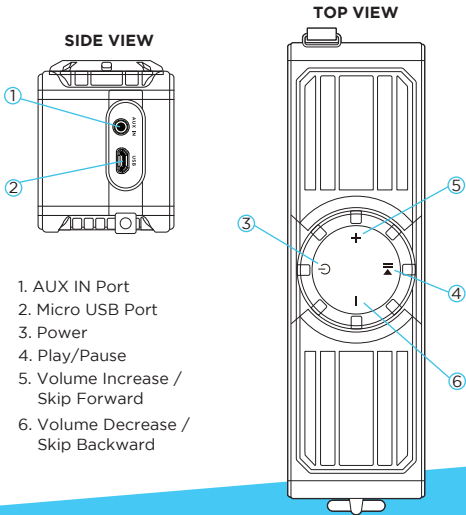

6



Getting Started

We know you're excited to start using your new EXO-400. And you should be. Luckily, these three easy steps will get you up and running quickly.

Step 1: Charge It

Connect your EXO-400 to a wall outlet using the USB AC adaptor or to a PC/laptop using the micro USB charging cable. The red LED directly below the bem logo will turn on during charging and will turn off when fully charged. Please allow approximately 2 hours to fully charge. You can use your EXO-400 while it's charging.



Step 2: Connect it

When your EXO-400 is fully charged or plugged into a wall outlet or PC, pair it with your smartphone or other Bluetooth enabled device.



1. Press the POWER button to turn on the speaker. A tone will sound to indicate that the speaker has powered on. The blue Bluetooth indicator LED directly below the bem logo will flash rapidly.



2. Activate Bluetooth on your smartphone or other Bluetooth enabled device (refer to your device user guide for details). Your smartphone/device will now begin searching for Bluetooth devices.

3. When your smartphone/device finishes searching, select “EXO-400” from the device list. When connected, another tone will sound and the blue LED will flash slowly.

After initial pairing, “EXO-400” will appear in your device list and a connection will automatically be established when the speaker is turned on and Bluetooth is activated on your device. A tone will sound when the device is powered on and a tone indicating a successful Bluetooth connection will follow.



NOTE: When you end the Bluetooth connection from your device, a two-tone chime will sound from the speaker to indicate that the connection was lost.

Step 3: Play it

Use your device to find the music you love. Hit play on your device (you can play/pause on the EXO-400 after initially playing from your device). Enjoy your music.

Operation Details

The below instructions will help you get the most use out of your EXO-400.

Power On/Off

Press the POWER button to turn on your EXO-400. A tone will sound to indicate that the speaker has powered on and the blue Bluetooth indicator LED directly below the bēm logo will flash rapidly.

Press the POWER button to turn off your EXO-400. No chime will sound when the unit is turned off, but the Bluetooth light will stop flashing.

Music Control

1. On your EXO-400:

- Press the PLAY/PAUSE button to play/pause your music.
- Press the SKIP FORWARD button to move forward one track.
- Press the SKIP BACKWARD button to move backward one track.

2. On your device: Play, pause, skip and otherwise control your music as you normally would.

Volume Control

1. On your EXO-400: Repeatedly press the VOLUME UP (+) button to increase the volume incrementally or hold the VOLUME UP (+) button to steadily increase the volume. Repeatedly press the VOLUME DOWN (-) button to decrease the volume incrementally or hold the VOLUME DOWN (-) button to steadily decrease the volume.

2. On your device: Adjust the volume of your music as you normally would.

NOTE:

When maximum volume is reached, the VOLUME UP (+) button will no longer increase the volume. If the VOLUME DOWN (-) button is pressed often enough or held long enough, the speaker will stop producing sound until the volume is increased again, but the speaker will remain on.

Maintenance

To keep your EXO-400 working well and looking sharp, simply wipe with a dry cloth as needed. Do not use cleaning agents as they may damage the finish.

Technical Specifications

Note: All specifications are subject to change without notice.

Product Name	EXO-400
Model Number	EXO400
Music Time	8 Hours
Bluetooth	V4.0 with auto pairing
Power Supply	DC IN and MICRO USB
Dimensions	6.8" x 2.5" x 2.0" (approximate)
Battery	Rechargeable 3.7V, 2000mAH
Bluetooth Range	40 Feet



Troubleshooting

Your EXO-400 is designed to operate easily and reliably. However, problems can arise from time to time. If you need a little help, check out these common issues and solutions.

Will Not Turn On

- Your EXO-400 may not be charged. Please charge for 2 hours.
- Make sure to firmly press and hold the POWER button.

Bluetooth Won't Connect

- Make sure your EXO-400 speaker is attempting to pair with your Bluetooth device (blue Bluetooth indicator LED flashing rapidly).
- Make sure the Bluetooth function on your smartphone or other Bluetooth enabled device is activated.
- Make sure you are within Bluetooth connectivity range (40 feet).

Poor Sound Quality/Volume

- Make sure your EXO-400 speaker is sitting on a level surface.
- Make sure your EXO-400 speaker is facing outward and is unobstructed

If issues persist, you can find additional suggestions and technical support at bemwireless.com/support.

FCC Statement

1. This device complies with Part 15 of the FCC Rules. Operation is subject to the following two conditions:

- (1) This device may not cause harmful interference.
- (2) This device must accept any interference received, including interference that may cause undesired operation.

C **€2200**

2. Changes or modifications not expressly approved by the party responsible for compliance could void the user's authority to operate the equipment.

NOTE: This equipment has been tested and found to comply with the limits for a Class B digital device, pursuant to Part 15 of the FCC Rules. These limits are designed to provide reasonable protection against harmful interference in a residential installation.

This equipment generates uses and can radiate radio frequency energy and, if not installed and used in accordance with the instructions, may cause harmful interference to radio communications.

FCC Statement (cont)

However, there is no guarantee that interference will not occur in a particular installation. If this equipment does cause harmful interference to radio or television reception, which can be determined by turning the equipment off and on, the user is encouraged to try to correct the interference by one or more of the following measures:

- Reorient or relocate the receiving antenna.
- Increase the separation between the equipment and receiver.
- Connect the equipment into an outlet on a circuit different from that to which the receiver is connected.
- Consult the dealer or an experienced radio/TV technician for help.

FCC Radiation Exposure Statement

This equipment complies with FCC radiation exposure limits set forth for an uncontrolled environment. This equipment should be installed and operated with minimum distance 20cm between the radiator & your body.

IC Caution.

- English:

This device complies with Industry Canada licence-exempt RSS standard(s). Operation is subject to the following two conditions: (1) This device may not cause interference, and (2) This device must accept any interference, including interference that may cause undesired operation of the device.

This equipment should be installed and operated with a minimum distance of 20 cm between the radiator and your body.

- French:

Le présent appareil est conforme aux CNR d'Industrie Canada applicables aux appareils radio exempts de licence. L'exploitation est autorisée aux deux conditions suivantes:

- (1) l'appareil ne doit pas produire de brouillage, et
- (2) l'utilisateur de l'appareil doit accepter tout brouillage radioélectrique subi, même si le brouillage est susceptible d'en compromettre le fonctionnement.

Cet équipement doit être installé et utilisé à une distance minimale de 20 cm entre le radiateur et votre corps.

Safety Instructions

This product is specially designed based on full attention to safety; in order to encourage accident-free operation, please follow the guidelines listed below:

- Do not drop, unpack, open, hit, bend, puncture, burn or otherwise attempt to damage/modify the set
- Avoid using the set in the rain or near basins or sinks where parts may come in contact with water
- Protect the set from all heat-producing devices, including radiators, forced air vents, cooking surfaces, and other heat-producing devices
- Set the volume properly to prevent damage to the unit and personal injury

Correct Disposal of this Product



This marking indicates that this product should not be disposed of with other household wastes throughout the EU. To prevent possible harm to the environment or human health from uncontrolled waste disposal, recycle it responsibly to promote the sustainable reuse of material resources. To return your used device, please use the return and collection systems or contact the retailer where the product was purchased. Retailers can take this product for environmentally safe recycling.

Safety Instructions (cont)

Warning

- The battery (battery or batteries or battery pack) shall not be exposed to excessive heat such as sunshine, fire or the like.
- CAUTION: Danger of explosion if battery is incorrectly replaced. Replace only with the same or equivalent type.

90-Day Limited Warranty

bēm wireless warrants this product against defects in materials and/or workmanship under normal use for a period of NINETY (90) DAYS from the date of purchase by the original purchaser (“Warranty Period”). If a defect arises and a valid claim is received within the Warranty Period, at its option bēm wireless will either 1) Repair the defect at no charge, using new or refurbished replacement parts or 2) Replace the product with a new product that is at least functionally equivalent to the original product. A replacement product or part, including a user-installable part installed in accordance with instructions provided by bēm wireless, assumes the remaining warranty of the original product. When a product or part is exchanged, any replacement item becomes your property and the replaced item becomes bēm wireless’s property.



Obtaining Service: To obtain warranty service, call bēm wireless at 1-815-337-0541 or e-mail customerservice@bemwireless.com. Please be prepared to describe the product that needs service and the nature of the problem. A purchase receipt will be required. All repairs and replacements must be authorized in advance. Service options, parts availability and response times will vary. You are responsible for delivery including the cost of delivery of the product or any parts to the authorized service center for replacements, per our instructions.



Limits and Exclusions: Coverage under this Limited Warranty is limited to the United States of America, including the District of Columbia and the U.S. Territories of Guam, Puerto Rico and U.S. Virgin Islands. This Limited Warranty applies only to products manufactured by or for bēm wireless that can be identified by the bēm wireless trademark, trade name, or logo affixed to them or its packaging. The Limited Warranty does not apply to any non-bēm wireless products.



bēm wireless
1725 Kilkenny Court
Woodstock, IL 60098 USA
www.bemwireless.com
©2015 bēm wireless All Rights Reserved.
Made in China

18

Stay in Touch!

For questions, comments, or to purchase additional bēm wireless products, go to: bemwireless.com.

You can also follow us at:



[facebook.com/bemwireless](https://www.facebook.com/bemwireless)



twitter.com/bemwirelessco



[youtube.com/bemwireless](https://www.youtube.com/bemwireless)



bemwireless.com

bēm wireless | 1725 Kilkenny Court | Woodstock IL 60098

© 2015 bēm wireless