

# Speaker Duo User's Manual

## Product overview

Thank you for purchasing the bem wireless Speaker Duo. Our speaker will bring you a new found freedom from wires while delivering an incredible sound. The Speaker Duo is compatible with all devices enabled with Bluetooth® technology... which is currently a lot of devices!

Make sure to read through the following directions, fully charge your device and perform the initial Bluetooth® syncing process and you should be up and running in no time. If you have any problems stop only [bemwireless.com](http://bemwireless.com) for the answers to all your questions.

### Package contents

- Matrix Case x 1
- Satellite Speaker x 2
- Power adapter x 1
- Aux cable x 1
- User's Manual x 1

If any of these were missing or damaged, please visit [bemwireless.com](http://bemwireless.com) to obtain replacement.

### Compatibility

- All devices enabled with Bluetooth technology, including iPhones, iPads, iPods, smartphones, laptops, tablets and more;
- Also compatible with any device that has a standard 3.5mm earphone jack such as MP3 players, PSP, mobile phones, etc.

## Meet the Speaker Duo

Before learning your Speaker Duo, take a moment to look it over and familiarize yourself with its features.

The Matrix Case

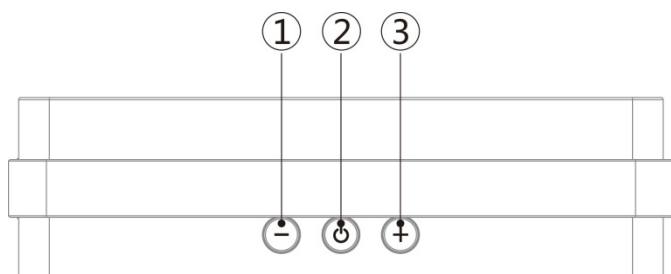

- (1) Volume –
- (2) Power / Pair
- (3) Volume +
- (4) Bluetooth® Indicator
- (5) Aux In
- (6) DC In
- (7) Charging Indicator
- (8) Connection Indicator
- (9) Handle

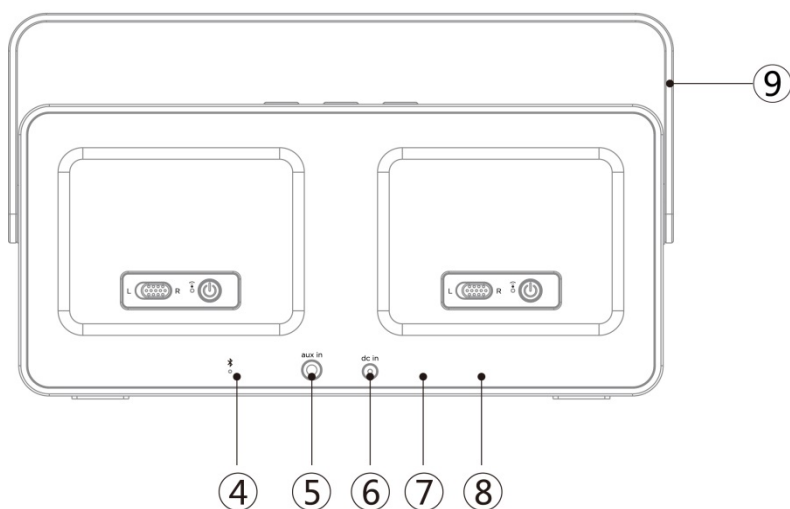

## The Satellite Speaker

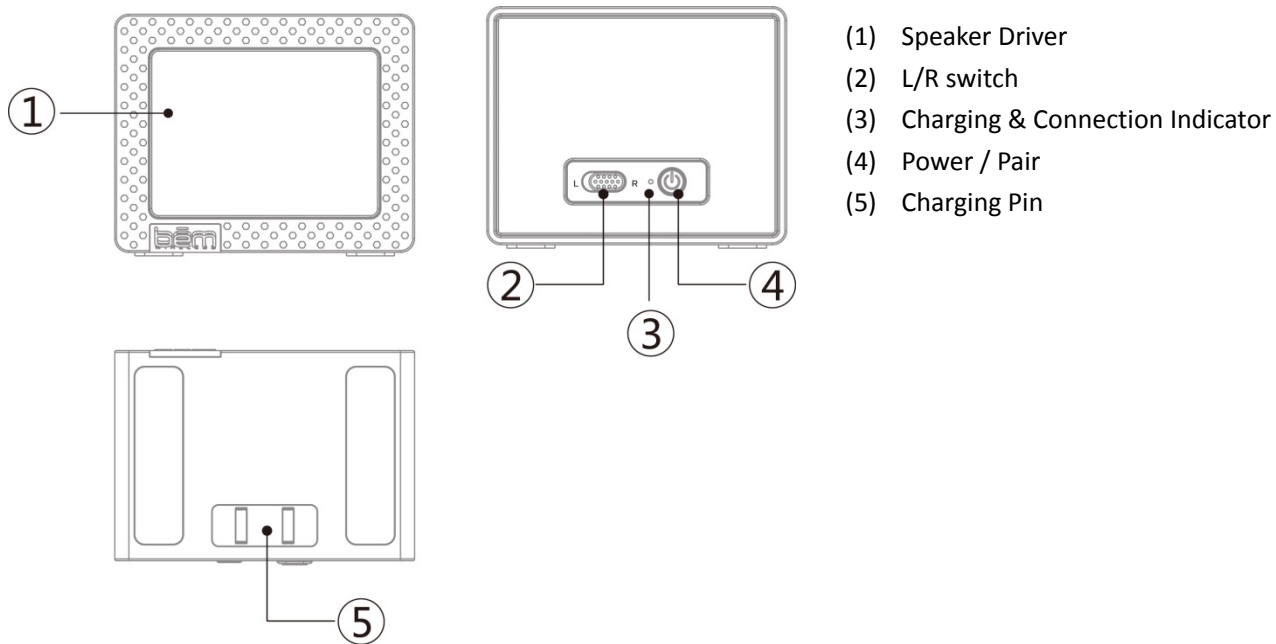

## Getting Started

We know you are excited to experience your new Speaker Duo. These two easy steps will get you up and running quickly.

### Step 1: Charge It

Connect your Speaker Duomatrix case to an outlet using the included power adapter. It will start charging the matrix case. Slide the satellitespeakers intothe case for charging. The red backlight will slowly flash during charging and goes out when it hasreached a complete charge (Approx. 3.5 hours).

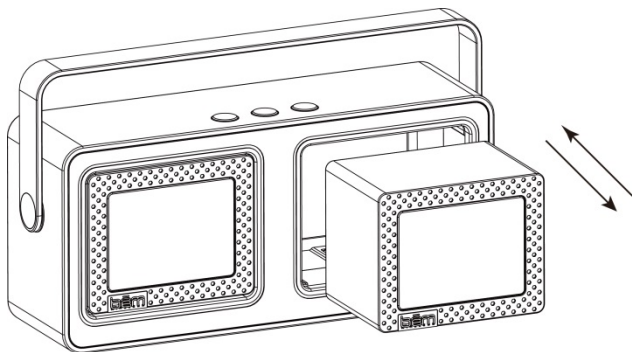

### Step 2: Connect it

There are two options for connecting to your Speaker Duo - wirelessly by Bluetooth® or wired using the included aux cable.

#### ● Connect Wirelessly

Turn on the power of the matrix case followed by powering on each of the 2satellitespeakers. Once the base is powered on the Bluetooth® indicator will lightand a tone confirming that the unit is currently in paring mode will sound.

Go to the Bluetooth® settings on your mobile phone, tablet or computerto find the device named "Speaker Duo". A tone will sound to confirm thedevice has paired successfully. Next time the Speaker Duo and connecteddevice will pair automatically. After completing this step you are ready tostart playing audio from your connected device.

Hold the Play/Pause button for 5 seconds will disconnect the connected device and enter pairing mode for pairing a new device.

#### ● Direct Connection

The Speaker Duo can also be connected to any device that has aheadphone jack or line out using the included aux cable. Please note the play/pause button only operates when connected via Bluetooth®.

## Operation Details

### Power on / Power off

Matrix Case: Press the power button to turn on the Matrix Case of Speaker Duo. The Bluetooth® indicator will light up to signify the unit is on and ready to be paired. Press the power button again to turn off the base and the Bluetooth indicator light will go out.

Satellite Speakers: Press the power button to turn the speaker on. The Indicator on the speaker will light up to signify the unit is on. Press the power button again to turn off the speaker and the Indicator will also go out.

*Please note, always make sure to first turn on the base unit before turning on the speakers*

### Play modes

Bluetooth mode: play an audio signal from the connected Bluetooth® device.

AUX mode: play an audio signal from the connected "wired" device.

Please note, if an Aux cable is connected to the speaker it will not play music from Bluetooth® connected devices.

### Select the L/R Channel

Use the L/R switch at the back of the Satellite Speaker to select the sound channel.

Switch to L to play left channel and R for right channel.

### Audio Use

Follow the above connection steps to pair a Bluetooth® device with the Speaker Duo. At this point you can send any kind of audio signal to your speaker (music, video, gaming, etc.). Just use your device as normal and the audio will play through your Speaker Duo.

### Controls

Press the Power/Pair button to play or pause the music when using a music player through your Bluetooth® connected device.

Pressing the + and - buttons will increase or decrease the volume on the Speaker Duo. Please note that this will not affect the volume levels on the connected device.

### Connection

Laptop / notebook / PC

As the Bluetooth® versions for these types of devices varies greatly, the connection methods will differ as well. If you can not connect with the Speaker Duo using the previous method instructed you may need to install a new version of the Bluetooth® driver.

Please reference the instructions of device for details.

### Speaker Placement

The Satellite matrix case has battery built-in, with the metal handle, it can be taken easily on the go.

The 2 individual speakers can be removed from the matrix case to be set anywhere you like. Approximate range is 50ft away from the case (open area). The Speaker Duo uses 5.8GHz signal so you're free to put the speakers where you like!

### Charging

Connect your matrix case to an outlet using the included power adapter. Place the speakers into the charging area of the case. The red backlight will slowly flash during charging and goes out when it has reached a complete charge (Approx. 3.5 hours).

Note: if the unit has not been used in the past 7 days please charge for 10 minutes before using the Speaker Duo.

## Troubleshooting

Issue: Pairing is unsuccessful after multiple attempts

Solution:

- Check if the Bluetooth® indicator light is on. If the indicator light is off, please press the power button to turn the unit on. If the Bluetooth® indicator light still doesn't come on after pressing the power button, please charge the unit.
- Check for other Bluetooth® devices around the surroundings that may interfere with searching and turn devices off.

- Power off and then power on the unit to restart the Bluetooth® function of the unit or your Bluetooth device
- Unplug any cables plugged into the AUX IN, restart all devices and then attempt pairing again.

Issue: Interference or static during playback

Solution:

- Avoid using the device between concrete or other building structures that may interfere with the signal.
- Please check if the battery level of the unit and the Bluetooth® device and charge if necessary.

For more troubleshooting help go to <http://bemwireless.com>

## Maintenance

Please follow the instructions below for cleaning your Speaker Duo

- Power off the unit and unplug the power adapter from wall outlet
- Use a soft, dry, lint-free cloth and wipe gently
- Do not use alcohol, benzene, thinners or other chemical detergents as these can cause the casing to be
- warped or discolored

For questions, comments or to purchase more bem wireless products go to [bemwireless.com](http://bemwireless.com)

## Storage

- Power off the Speaker Duo If the unit will not be used for an extended period of time.
- Do not set the unit in a damp environment, high temperatures or in direct sunlight.

## Technical Specifications

Note: All specifications are subject to change without notice

- Product Name : Speaker Duo
- Model Number :HL2506
- Power Supply: USB 5V,2A
- Output power: 2.5W X 2
- Battery capacity: 3.7V 2000mAhfor the case ,3.7V 1000mAh for the speaker
- Bluetooth V4.0+EDR, profile Supported: A2DP, AVRCP
- Working range: Approximately 25ft, 8m
- Working atmosphere: 0°C-40°C / 20%-90%RH

## FCC Statement

1. This device complies with Part 15 of the FCC Rules. Operation is subject to the following two conditions:

- (1) This device may not cause harmful interference.
- (2) This device must accept any interference received, including interference that may cause undesired operation.

2. Changes or modifications not expressly approved by the party responsible for compliance could void the user's authority to operate the equipment.

NOTE: This equipment has been tested and found to comply with the limits for a Class B digital device, pursuant to Part 15 of the FCC Rules. These limits are designed to provide reasonable protection against harmful interference in a residential installation.

This equipment generates uses and can radiate radio frequency energy and, if not installed and used in accordance with the instructions, may cause harmful interference to radio communications. However, there is no guarantee that interference will not occur in a particular installation. If this equipment does cause harmful interference to radio or television reception, which can be determined by turning the equipment off and on, the user is encouraged to try to

correct the interference by one or more of the following measures:

- Reorient or relocate the receiving antenna.
- Increase the separation between the equipment and receiver.
- Connect the equipment into an outlet on a circuit different from that to which the receiver is connected.
- Consult the dealer or an experienced radio/TV technician for help

## Safety Instructions

This product is specially designed based on the full attention to safety; in order to make sure the accident-free operation, please abide the guidelines listed below:

- Always position the unit on a stable and level surface. Unstable surface can cause the unit to topple and fall, resulting in possible damage or injury
- Do not drop, unpack, open, beat, curve, prick and burn the unit
- Avoid using the unit nearby basins or sinks where it may come in contact with water
- Do not place any ware with full water on the top of the unit, such as vase, glass, pot, and please avoid placing candle on the speaker surface as well
- Protect the using of the unit from any overheating devices (such as radiator, heating installation, cooking stove or other heating devices)
- Regardless of what reasons cause the unit damage, please ask for the maintenance personnel to repair
- If you want to do the cleaning, please turn off the unit and unplug the power cable from the outlet first
- Set the volume properly to prevent injury to the unit and your personal health

Correct Disposal of this product. This marking indicates that this product should not be disposed with other household wastes throughout the EU. To prevent possible harm to the environment or human health from uncontrolled waste disposal, recycle it responsibly to promote the sustainable reuse of material resources. To return your used device, please use the return and collection systems or contact the retailer where the product was purchased. They can take this product for environmental safe recycling.

The device has been evaluated to meet general RF exposure requirement. The device can be used in portable exposure condition without restriction.