

DWG. NO. **025-4315-500** REV **1**

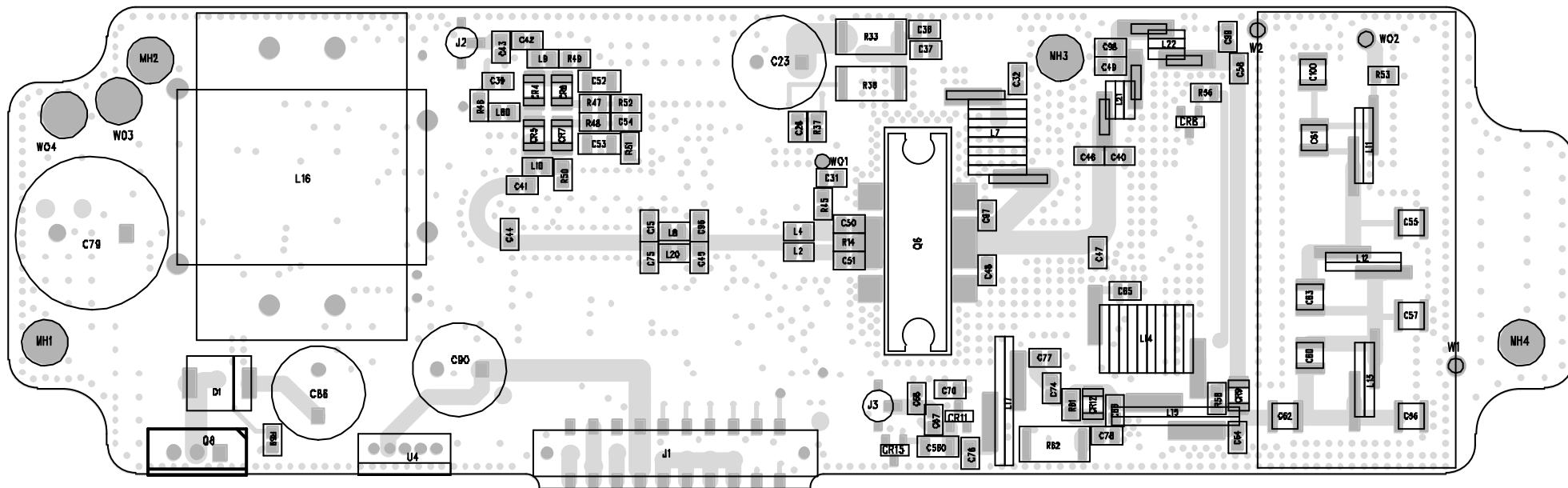

035-4315-540 (TOP)

VHF 15W PA BOARD LAYOUT TOP VIEW

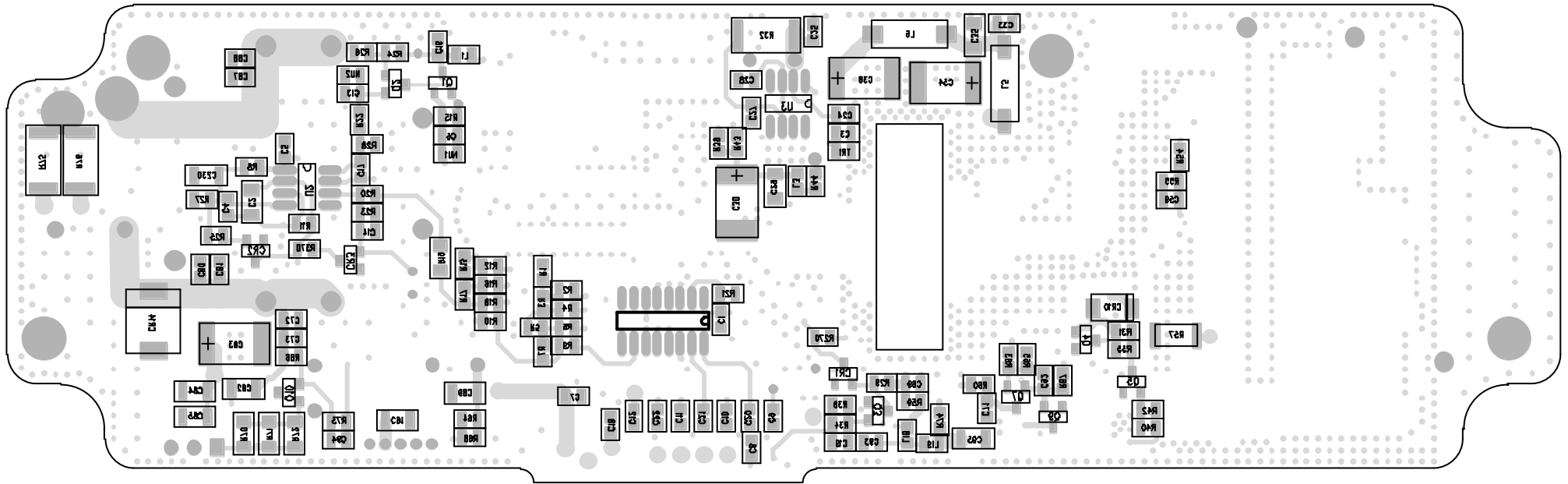

035-4315-540 (BOTTOM)

VHF 15W PA BOARD LAYOUT BOTTOM VIEW

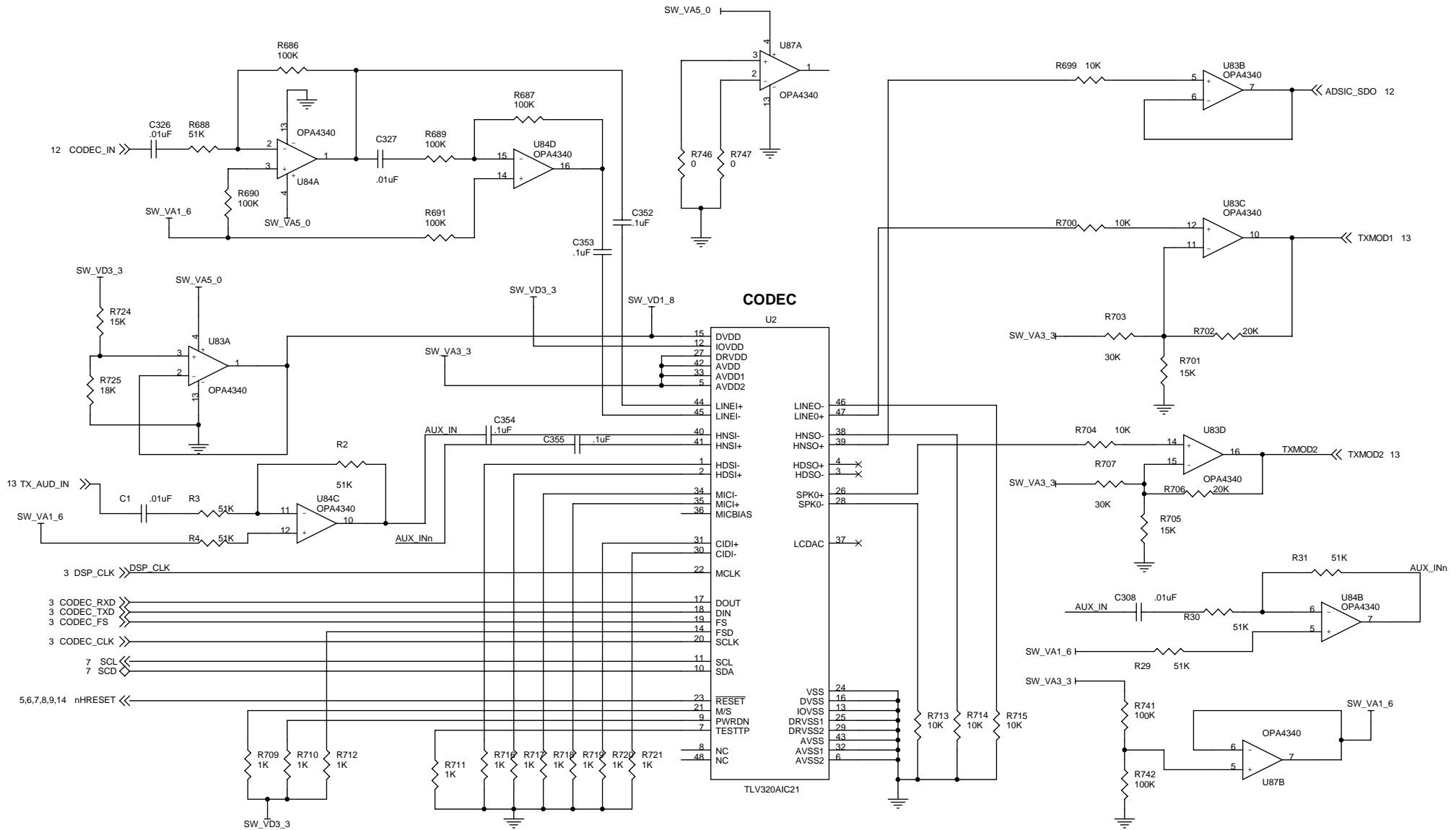

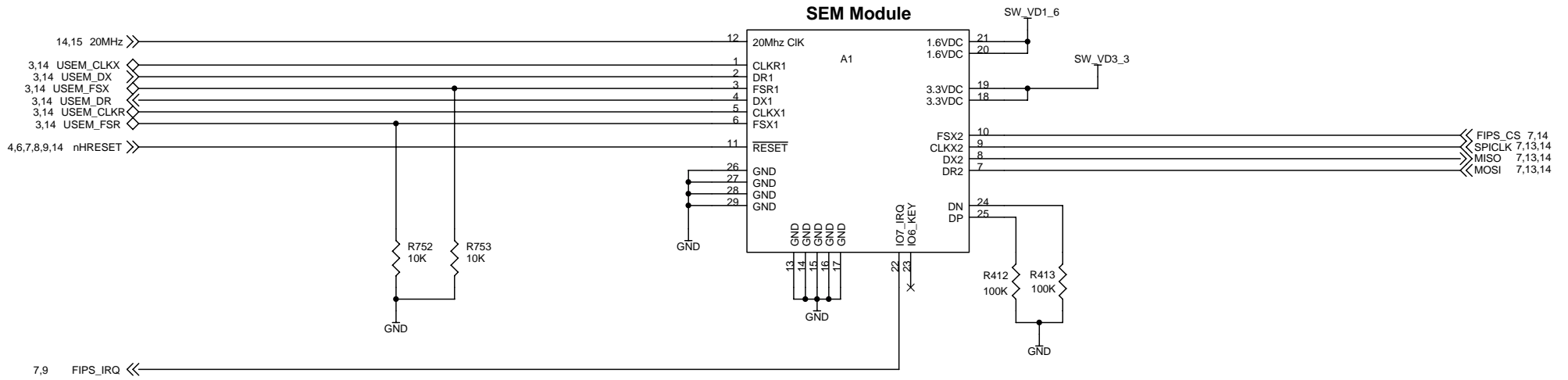

For Factory Use Only

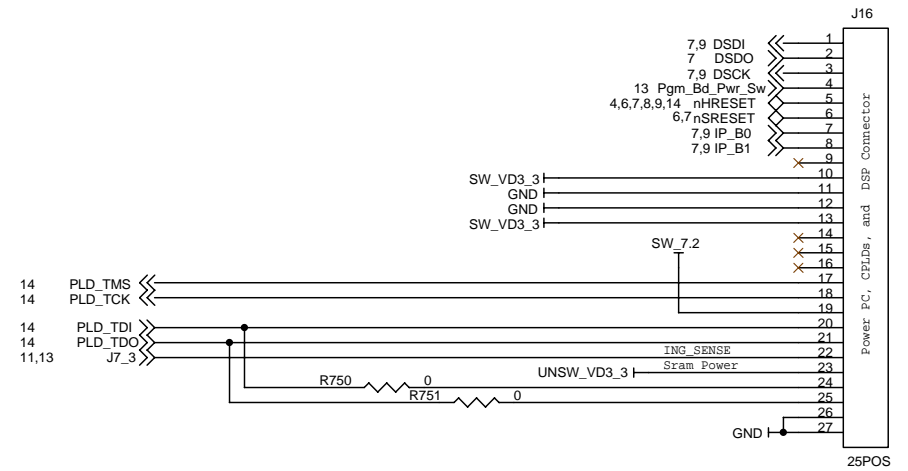

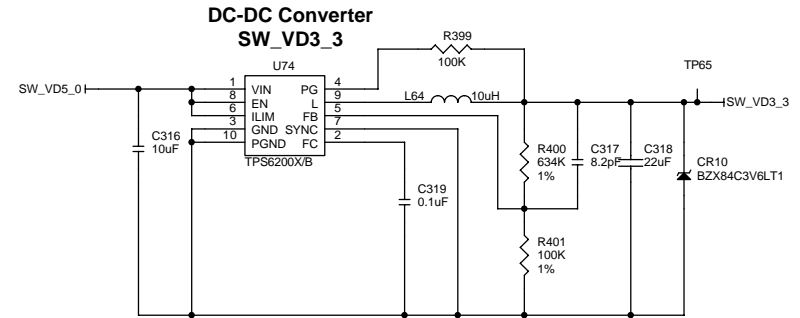
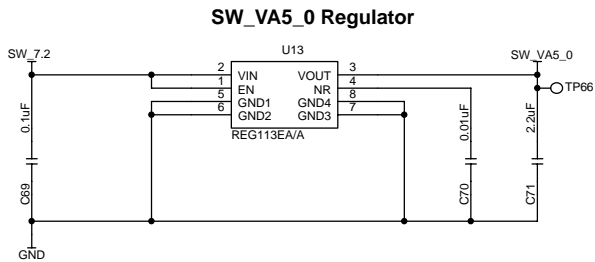
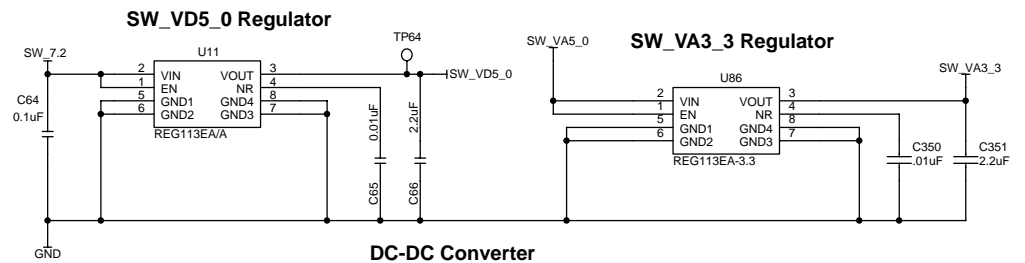
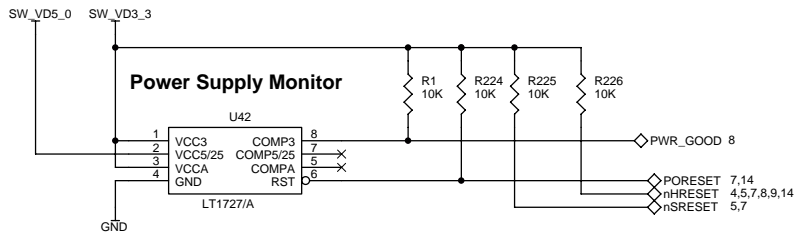

5V Regulator

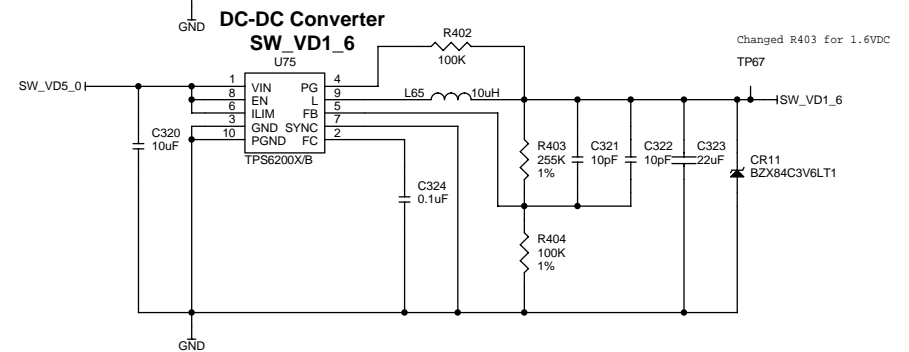
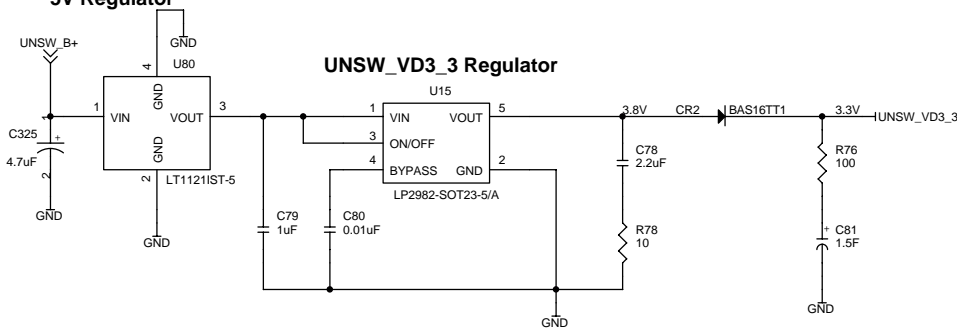

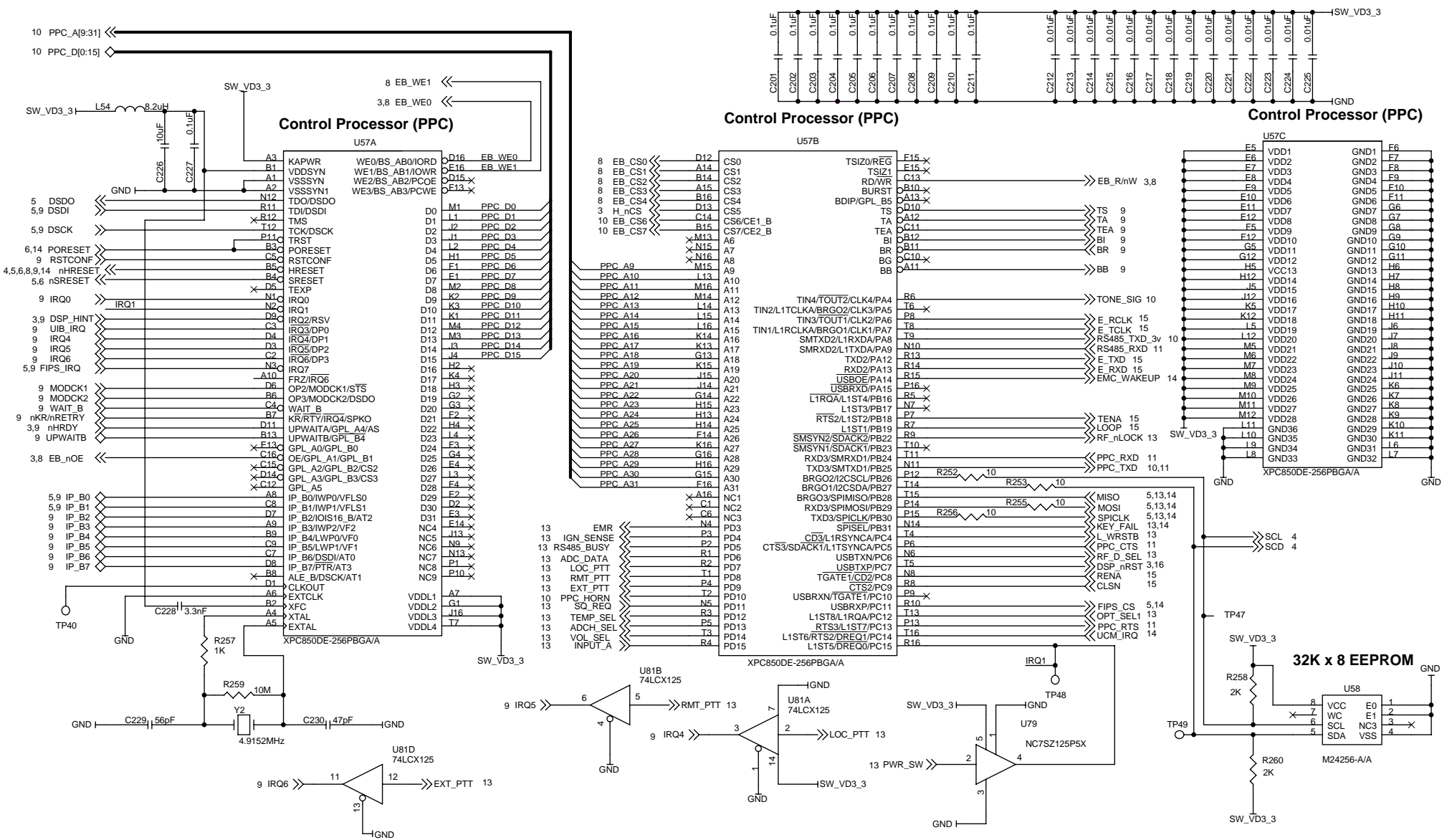

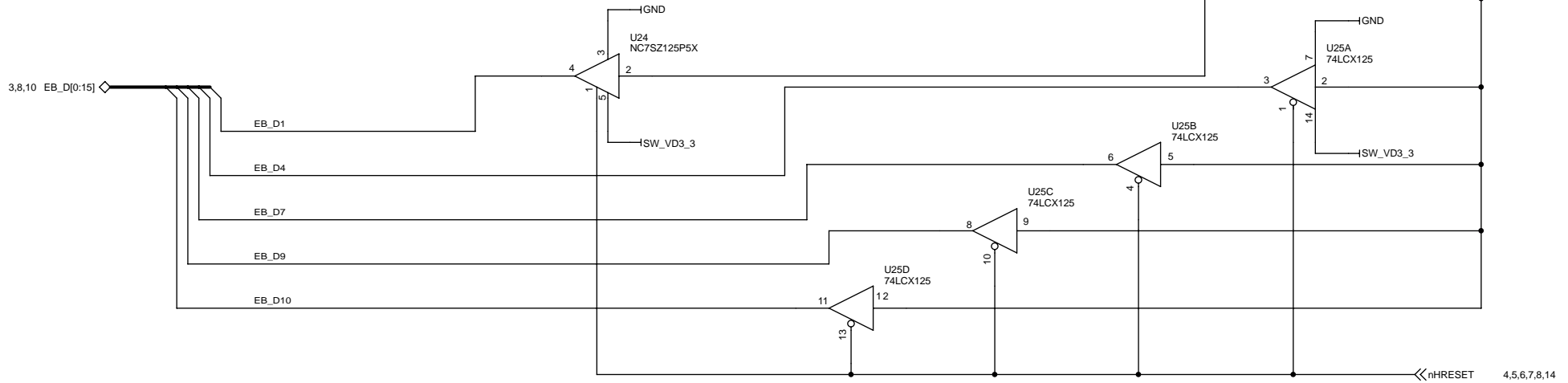
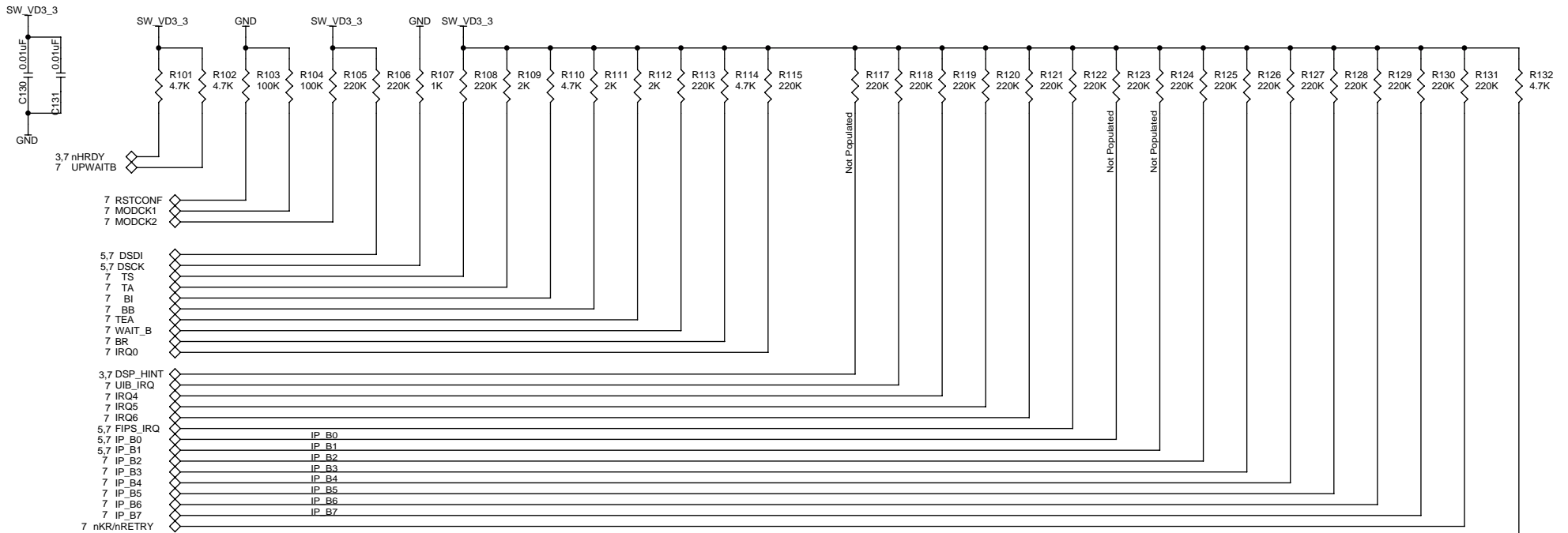

Pull Ups - Pull Downs

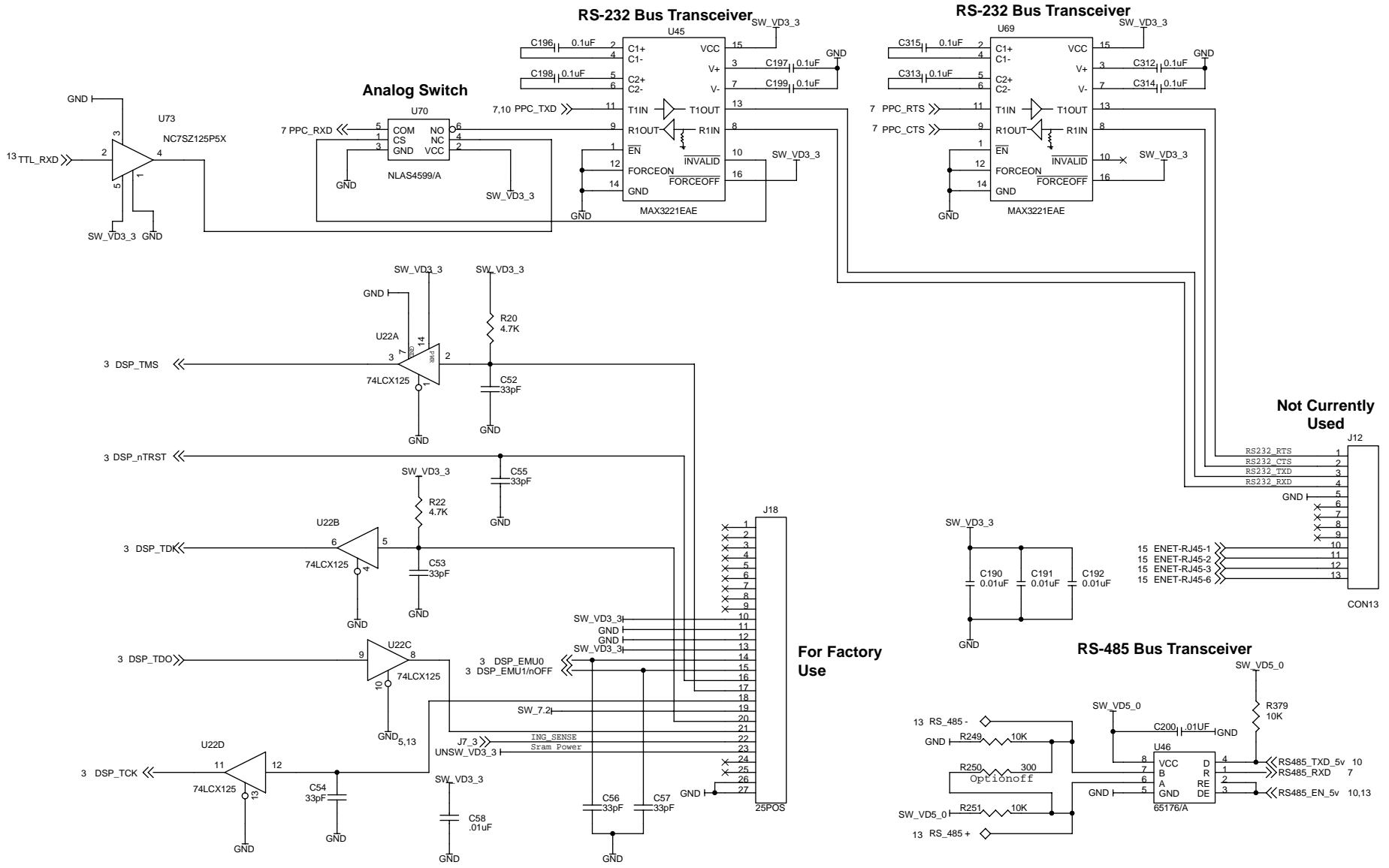

Not Currently Used

For Factory Use

