

## **APPENDIX F: USER MANUAL**

Please refer to the following pages; new speaker/microphone added.



**EFJohnson®**

**PRELIMINARY**

# **Service Manual**

## **5100 SERIES PORTABLE DIGITAL/ANALOG VHF/UHF/800 MHz**

7.2 VDC

5 & 1 W (VHF), 4 & 1 W (UHF), 3 W (800 MHz)

Part No. 242-51xx-xxx



First Printing  
September 2001



# **51xx SERIES PORTABLE**

## **VHF/UHF/800 MHz**

### **PROJECT 25 (DIGITAL) AND ANALOG**

**7.5 VDC**  
**5 & 1 W (VHF), 4 & 1 W (UHF), 3 W (800 MHz)**  
**Part No. 242-51xx-xxx**

Copyright© 2001 by the E.F. Johnson Company

The E.F. Johnson Company, which was founded in 1923, provides wireless communication systems solutions for public safety, government, and commercial customers. The company designs, manufactures, and markets conventional and trunked radio systems, mobile and portable subscriber radios, repeaters, and Project 25 digital radio products. E.F. Johnson is a wholly owned subsidiary of Transcrypt International, Inc.

Viking Head/EFJohnson logo, Call Guard<sup>®</sup>, PCTrunk<sup>™</sup>, and PCTune<sup>™</sup> are registered trademarks of the E.F. Johnson Company. SMARTNET<sup>™</sup>, SmartZone<sup>®</sup>, SecureNet<sup>™</sup>, Call Alert<sup>™</sup>, Enhanced Private Conversation<sup>™</sup>, and Private Conversation II<sup>™</sup> are trademarks of Motorola, Inc. All other company and/or product names used in this manual are trademarks and/or registered trademarks of their respective manufacturer. The IMBE<sup>™</sup> voice coding technology embodied in this product is protected by intellectual property rights including patent rights of Digital Voice Systems, Inc.

Information in this manual is subject to change without notice.

TABLE OF CONTENTS

<b>1</b>	<b>GENERAL INFORMATION</b>	
<b>1.1</b>	<b>SCOPE OF MANUAL</b>	1-1
<b>1.2</b>	<b>TRANSCEIVER DESCRIPTION</b>	1-1
	General	1-1
	Analog/Digital Operation	1-1
	Operating Protocols	1-1
	18-Key/6-Key Models	1-1
	Systems, Channels, and Zones	1-1
	Secure Communication	1-2
	Programming	1-2
	Alignment	1-2
<b>1.3</b>	<b>PRODUCT WARRANTY</b>	1-2
<b>1.4</b>	<b>PART NUMBER BREAKDOWN</b>	1-3
<b>1.5</b>	<b>TRANSCEIVER IDENTIFICATION</b>	1-3
<b>1.6</b>	<b>ACCESSORIES</b>	1-3
<b>1.7</b>	<b>FACTORY CUSTOMER SERVICE</b>	1-4
<b>1.8</b>	<b>FACTORY RETURNS</b>	1-5
<b>1.9</b>	<b>REPLACEMENT PARTS</b>	1-5
<b>1.10</b>	<b>INTERNET HOME PAGE</b>	1-5
<b>2</b>	<b>OPERATION</b>	
<b>2.1</b>	<b>FEATURES</b>	2-1
	General Features	2-1
	Conventional Features	2-1
	SMARTNET/SmartZone Features	2-1
<b>2.2</b>	<b>OPTION SWITCH FUNCTIONS</b>	2-1
<b>2.3</b>	<b>CONTROLS AND DISPLAY</b>	2-2
	Front Panel Controls	2-2
	Top Panel Controls	2-3
	Side Controls	2-4
	Display	2-4
<b>2.4</b>	<b>GENERAL OPERATION</b>	2-5
	Introduction	2-5
	Turning Power On and Setting Volume	2-5
	Power-Up Password	2-5
	Backlight	2-5
	Option Switches	2-6
	Keypad Lock	2-6
	Low Battery Indication	2-6
	Channel and Zone Selection	2-6
	Home Zone	2-7
	Time-Out Timer	2-7
	Tone Enable/Disable	2-7
	Transceiver Operating Modes	2-7
	Secure Communication	2-8
<b>2.5</b>	<b>SCANNING</b>	2-8
	Introduction	2-8
	Standard Scanning	2-8
	Radio Wide Scanning	2-8
	Scan Resume Delay	2-9
	Standard Mode Scan List	2-9
	Radio Wide Mode Scan List	2-9
	Determining Which Channels are in Scan List	2-9
	Nuisance Channel Delete	2-9
	Programming a Scan List	2-9
<b>2.6</b>	<b>CONVENTIONAL FEATURES</b>	2-10
	Introduction	2-10
	Display Mode Selection	2-10
	Monitoring Before Transmitting	2-10
	Monitor Mode	2-11
	Busy Channel Lockout	2-11
	Call Guard Squelch	2-11
	Penalty Timer	2-12
	Conversation Timer	2-12
	Repeater Talk-Around	2-12
	Power Output Select	2-13
	Emergency Mode (Conventional)	2-13
	Conventional Mode Scanning	2-13
	Priority Channel Sampling	2-14
	Placing and Receiving Standard Conventional Calls	2-14
	DTMF/ANI Signaling	2-15
	Project 25 Mode Features	2-15
	Conventional Secure Communication	2-16
<b>2.7</b>	<b>SMARTNET/SMARTZONE FEATURES</b>	2-17
	Introduction	2-17
	Viewing Unit ID	2-17
	Standard Group Calls	2-17
	Enhanced Private Conversation Calls	2-18
	Private Conversation II Calls	2-20
	Telephone Calls	2-21
	Call Alert	2-22
	Messaging	2-23
	Sending Status Conditions	2-23
	Emergency Alarm and Emergency Call	2-23
	Failsoft Operation	2-24
	SMARTNET/SmartZone Scanning	2-24
	Dynamic Regrouping	2-24
	SmartZone Features	2-24
	SMARTNET/SmartZone Secure Communication	2-25
<b>2.8</b>	<b>SUPERVISORY TONES</b>	2-25
<b>2.9</b>	<b>KEYPAD PROGRAMMING</b>	2-26
	Introduction	2-26
	Menu Structure	2-26
	Cloning	2-27
	Timer Programming	2-27
	Channel Programming	2-27

TABLE OF CONTENTS (CONT'D)

<b>3</b>	<b>TRANSCEIVER PROGRAMMING</b>	
<b>3.1</b>	<b>GENERAL</b> . . . . .	3-1
	Programming Setup . . . . .	3-1
	Computer Description . . . . .	3-1
	PCTrunk Software Installation . . . . .	3-1
	Connecting Computer To Transceiver . . . . .	3-2
	Starting and Exiting . . . . .	3-2
	Programming File Types . . . . .	3-2
	Help Files . . . . .	3-2
	Screen Groups . . . . .	3-2
	Displaying Screens . . . . .	3-2
	File Size Indicator . . . . .	3-3
	Creating and Displaying Systems . . . . .	3-3
<b>3.2</b>	<b>PROGRAMMING PROCEDURE</b> . . . . .	3-4
	Preliminary . . . . .	3-4
	Programming Radio Wide Parameters . . . . .	3-4
	Programming Conventional Systems . . . . .	3-4
	Programming SMARTNET and SmartZone Systems . . . . .	3-4
	Programming Radio (Downloading File) . . . . .	3-4
<b>3.3</b>	<b>MENU COMMANDS</b> . . . . .	3-5
	File Menu . . . . .	3-5
	Radio Series Menu . . . . .	3-5
	Download Menu . . . . .	3-5
	Upload Menu . . . . .	3-6
	Systems Menu . . . . .	3-6
	Tools Menu . . . . .	3-6
	Window Menu . . . . .	3-6
	Help Menu . . . . .	3-6
<b>3.4</b>	<b>RADIO-WIDE PARAMETER SCREENS</b> . . . . .	3-6
	Introduction . . . . .	3-6
	Radio-Wide General screen . . . . .	3-6
	Radio-Wide Conventional Screen . . . . .	3-10
	Radio-Wide SMARTNET/SmartZone Screen . . . . .	3-11
	Radio-Wide Portable Options Screen . . . . .	3-12
<b>3.5</b>	<b>PROGRAMMING CONVENTIONAL SYSTEMS AND CHANNELS</b> . . . . .	3-12
	Introduction . . . . .	3-12
	Conventional System General Screen . . . . .	3-12
	Conventional System Individual Call List Screen . . . . .	3-14
	Conventional System Talk Group Screen . . . . .	3-15
	Setting Up Conventional Channels . . . . .	3-15
	Conventional Analog Channel Screen Parameters . . . . .	3-16
	Conventional Project 25 (Digital) Channel Screen Parameters . . . . .	3-18
<b>3.6</b>	<b>PROGRAMMING SMARTNET/SMARTZONE SYSTEMS AND CHANNELS</b> . . . . .	3-19
	Introduction . . . . .	3-19
	SMARTNET/SmartZone System General Screen . . . . .	3-19
	SMARTNET/SmartZone System Other ID's Screen . . . . .	3-20
	SMARTNET/SmartZone System Phone Interconnect Screen . . . . .	3-20
	SMARTNET/SmartZone System Talk Groups Screen . . . . .	3-21
	SMARTNET/SmartZone System Emergency Settings Screen . . . . .	3-22
	SMARTNET/SmartZone System Lists Screens . . . . .	3-23
	Setting Up SMARTNET/SmartZone Channels . . . . .	3-26
	SMARTNET/SmartZone Channel Screen Parameters . . . . .	3-27
<b>3.7</b>	<b>PASSWORD OPERATION</b> . . . . .	3-28
	General . . . . .	3-28
	Power-Up Password . . . . .	3-28
	Programming Password . . . . .	3-29
<b>4</b>	<b>CIRCUIT DESCRIPTION</b>	
<b>4.1</b>	<b>GENERAL OVERVIEW</b> . . . . .	4-1
	Introduction . . . . .	4-1
	Analog Mode . . . . .	4-1
	Project 25 Digital Mode . . . . .	4-2
	RF Board . . . . .	4-2
	Digital Board . . . . .	4-3
	Keypad/Display Board . . . . .	4-3
<b>4.2</b>	<b>POWER SUPPLY</b> . . . . .	4-4
	General . . . . .	4-4
	Power On Operation . . . . .	4-4
	Power Off Operation . . . . .	4-4
	Low Voltage Detect . . . . .	4-4
<b>4.3</b>	<b>RF BOARD CIRCUIT DESCRIPTION</b> . . . . .	4-5
	Frequency Generation Unit . . . . .	4-5
	Antenna Switch . . . . .	4-6
	Receiver Front End . . . . .	4-6
	Receiver Back End . . . . .	4-6
	Transmitter . . . . .	4-6
<b>4.4</b>	<b>DIGITAL BOARD</b> . . . . .	4-7
	Introduction . . . . .	4-7
	Digital Signal Processing Overview . . . . .	4-7
	Receive Signal Path . . . . .	4-7
	Transmit Signal Path . . . . .	4-8
	DSP Chip (U12) . . . . .	4-9
	UART . . . . .	4-11
	ADSIIC . . . . .	4-11
<b>4.5</b>	<b>KEYPAD BOARD</b> . . . . .	4-11
	Introduction . . . . .	4-11
	Functional Description . . . . .	4-11
	Microcontroller . . . . .	4-12
	Low Voltage Detect . . . . .	4-12
	LCD Displays and Display Drivers . . . . .	4-12
	Audio Circuits . . . . .	4-12
	Voltage Regulation . . . . .	4-13

**TABLE OF CONTENTS (CONT'D)**

**4.6 TRANSMIT FREQUENCY DETERMINATION** .....4-13

**4.7 HARMONIC FILTER** .....4-13

**5 ALIGNMENT PROCEDURE**

**5.1 GENERAL** .....5-1

Introduction ..... 5-1

Tune Software ..... 5-1

Preliminary ..... 5-2

**5.2 TRANSMIT FREQUENCY TUNING** .....5-2

**5.3 TRANSMIT MODULATION TUNING** .....5-2

**5.4 TRANSMIT POWER ADJUSTMENT** .....5-3

**5.5 RECEIVE SENSITIVITY TUNING** .....5-3

**5.6 SQUELCH ADJUSTMENT** .....5-3

**5.7 RSSI ADJUSTMENT** .....5-4

**6 PARTS LIST**

RF Board (A450) ..... 6-1

Digital Board ..... 6-1

Keypad Board ..... 6-4

Exploded Views ..... 6-9

**8 SCHEMATIC DIAGRAMS AND COMPONENT LAYOUTS**

VHF RF Board Schematic ..... 8-1

VHF RF Board Layout ..... 8-2

UHF RF Board Schematic ..... 8-3

UHF RF Board Layout ..... 8-4

800 MHz RF Board Schematic ..... 8-5

800 MHz RF Board Layout ..... 8-6

Logic Board (Rev. 3) Schematic ..... 8-7

Revised Keypad Board Schematic ..... 8-8

**LIST OF FIGURES**

2-1 Front Panel Controls ..... 2-3

2-2 Top Panel Controls ..... 2-3

2-3 Keypad Programming Flowchart ..... 2-26

3-1 Programming Setup ..... 3-1

3-2 Main Screen (Later PCTrunk Versions) ..... 3-3

3-3 Conventional Analog Channel Screen ..... 3-16

3-4 Conventional Project 25 Digital Ch. Screen... 3-18

3-5 SMARTNET/SmartZone Channel Screen ... 3-27

4-1 Power Supply Diagram ..... 4-3

4-2 RF Board Block Diagram ..... 4-5

4-3 Memory Utilization ..... 4-10

5-1 Alignment Setup ..... 5-1

5-2 Tuning Software Screen (800 MHz Models) ... 5-3

**LIST OF TABLES**

1-1 5300 Mobile Accessories .....1-5

2-1 Control Unit DIP Switch and Jumper Settings . 2-7

3-1 Programmable Option Switch Functions ..... 3-5

4-1 Call Guard (CTCSS/DCS) Codes and Tones ... 4-20

5-1 LO and First IF Frequencies .....5-3

## SECTION 1 GENERAL INFORMATION

### 1.1 SCOPE OF MANUAL

This service manual contains alignment and service information for the E.F. Johnson 5100-Series portable digital transceivers.

### 1.2 TRANSCEIVER DESCRIPTION

#### 1.2.1 GENERAL

The 5100-series portable digital transceivers have multiple system select capability to allow operation in various types of radio systems (see next sections). Models are available for operation in the following frequency range: 806-870 MHz.

Repeater talk-around, which allows transmitting on the receive frequency, is also available with all bands. Power output is user switchable for low and high levels as follows:

800 MHz - 3 watts only

#### 1.2.2 ANALOG/DIGITAL OPERATION

The 5100-series transceivers use a digital signal processor (DSP) to provide the signal modulation required to operate on the following types of channels. This provides backwards compatibility with existing equipment and also the ability to operate on various types of radio systems.

Wideband Analog - FM modulation is used with a maximum deviation of 5 kHz. This mode is usually used in systems where the channel spacing is 25 kHz or 30 kHz.

Project 25 Digital - Operates on Project 25 compatible systems. The voice is digitized, error corrected,

optionally encrypted, and then transmitted using C4FM modulation according to the Project 25 standard. This mode uses a channel spacing of 12.5 kHz.

#### 1.2.3 OPERATING PROTOCOLS

The 5100-series transceivers can be programmed for all the following operating protocols. Refer to Section 2 for more operation information.

- Conventional analog
- Conventional Project 25 (digital)
- Trunked Project 25 (digital)
- SMARTNET<sup>®</sup> /SmartZone<sup>®</sup> analog or Proj 25 (digital)
- Multi-Net<sup>®</sup> trunked (analog)

#### 1.2.4 18-KEY/6-KEY MODELS

Both 18-key and 6-key models are available. The 18-key version includes number keys 0-9 for making telephone calls, entering unit or group ID numbers, and keypad programming. The other keys (\*, #, and F1-F4) have dual functions. They can be assigned a function using the programming software and are also used to navigate through menus. The 6-key models have keys below the display which are programmable function keys, and also keys that are used for menu navigation.

#### 1.2.5 SYSTEMS, CHANNELS, AND ZONES

A zone and channel are selected to place and receive calls. The following describes the relationship between systems, channels, and zones.

##### Systems

A system as used with this transceiver is a collection of channels (talk groups) belonging to the same repeater site. A system defines all the parameters and protocol definitions required to access a site. Up to 1 conventional system and 15 SMARTNET/SmartZone systems can be programmed (16 total).

## Channels

A channel selects a radio channel or talk group in a system as follows:

**Conventional Analog Mode** - A channel selects a specific radio channel, Call Guard (CTCSS/DCS) squelch coding, and other parameters unique to that channel.

**Conventional Project 25 Mode** - A channel selects a specific radio channel, NAC squelch coding, and other parameters unique to that channel.

**SMARTNET/SmartZone Operation** - A channel selects a specific talk group, announcement group, emergency group, and other parameters unique to that channel.

A maximum of up to 256 channels can be programmed with the preceding modes. The conventional system can be programmed with up to 256 channels, and each of the SMARTNET/SmartZone systems can be programmed with up to 256 talk groups (channels).

Therefore it is theoretically possible to program any combination of these systems that produces up to 256 total channels. However, the maximum number may be limited by the available memory. For example, since more memory is required to program a SMARTNET system than a conventional system, the total number of channels decreases as the number of SMARTNET systems increases. The programming software displays a bar graph which shows the amount of available memory space that is used by the current data. Refer to Section 3.1.10 for more information.

## Zones

A zone is a collection of up to 16 channels of any type (conventional or SMARTNET/SmartZone). For example, a zone could include 12 conventional channels and 4 SMARTNET channels. Zones are similar to banks used in other E.F. Johnson transceivers. One use of zones may be to program the channels used for operation in a specific geographical area. Up to 16 zones can be programmed.

## 1.2.6 SECURE COMMUNICATION

Secure communication is available with all the preceding protocols. The following types of encryption are available:

### Conventional Analog and SMARTNET/SmartZone Operation

- 460 Scrambling (Transcrypt)

### Conventional Project 25 Operation

- DES-OFB

## 1.2.7 PROGRAMMING

Transceiver programming is performed using a PC-compatible computer and an E.F. Johnson 5100 series programming cable and PCTrunk™ programming software (see Table 1-1). Programming is described in Section 3.

## 1.2.8 ALIGNMENT

Transceiver alignment is performed using the same computer and cable used for programming (see preceding section). In addition, special PCTune™ software, the Radio Interface Box (RIB), and a computer cable are required. All adjustments are made using the software (no manual adjustments are required). Refer to Section 5 for alignment information.

## 1.3 PRODUCT WARRANTY

The warranty statement for this transceiver is available from your product supplier or from the Warranty Department, E.F. Johnson Company, 299 Johnson Avenue, P.O. Box 1249, Waseca, MN 56093-0514. This information may also be requested from the Warranty Department by phone as described in Section 1.7. The Warranty Department may also be contacted for Warranty Service Reports, claim forms, or any other questions concerning warranties or warranty service.



### 1.4 PART NUMBER BREAKDOWN

The following is a breakdown of the part number used to identify this transceiver. Some combinations are not available.

**242-51FT-SEC-OADE**

#### F (Frequency Band)

- 1 - VHF (136-174 MHz)
- 3 - UHF (403-470 MHz)
- 4 - UHF (450-512 MHz)
- 8 - 800 MHz

#### T (Type)

- 0 - Standard
- 1 - Intrinsically Safe

#### S (Signaling, Primary)

- 0 - Analog
- 1 - Digital/Analog
- 3 - Digital/Analog, SMARTNET II
- 5 - Digital/Analog, SmartZone
- 7 - Project 25 Trunking

#### E (Encryption, Hardware)

- 0 - No encryption
- 5 - Project 25 DES

#### C (Configuration)

- 2 - 6-Key, w/accessories
- 3 - DTMF, w/accessories
- 7 - 6-Key, w/o accessories
- 8 - DTMF, w/o accessories

#### O (Options, Installed Conventional)

- A - No installed options, conventional

#### A (Analog or Additional Signaling)

- A - No additional signaling
- C - SMARTNET II (analog or digital/analog)
- D -
- E - SmartZone (analog or digital/analog)

#### D (Data Options)

- A - No data
- B - Circuit Data
- C - Packet Data
- D - Circuit and Packet Data

#### E (Encryption and Security Software)

- A - No encryption
- B - SC20-460
- C - SC20-DES/460

### 1.5 TRANSCEIVER IDENTIFICATION

The transceiver identification number is printed on a label that is attached to the chassis. The following information is contained in the identification number:

Model From P.N.	Revision Letter	Manufacture Date	Warranty Plant	Warranty Number
51xx x	A	23 1	A	12345
0 = Analog 1 = Digital		Week No. of Year	A = Waseca Last Digit of Year	

### 1.6 ACCESSORIES

The accessories available for this transceiver are listed in Table 1-1. A brief description of some of these accessories follows:

**Battery, NiMH** - The 3500 mAH nickel-metal hydride battery provides up to 16 hours of operation at a 5-5-90 duty cycle.

**Battery, NiCd** - The 1500 mAH nickel-cadmium battery provides up to 8 hours of operation at a 5-5-90 duty cycle.

**Charger, Single-Unit Rapid** - Charges one battery at a time. Typical charge time for the NiMH battery packs is 1-3 hours. Do not attempt to charge the alkaline battery pack.

**Charger, Six-Unit Multi** - Charges up to six NiMH batteries at a time. The optional wall mounting kit allows this charger to be mounted on a wall. Typical charge time for the NiMH battery packs is 1-2 hours. Do not attempt to charge the alkaline battery pack.

**Speaker/Microphones** - These microphones include a replaceable coil cord, swivel clip, and quick disconnect latch. A screwdriver is not required to attach or remove the latch (although it can be secured with a screw if necessary).

**Table 1-1 Accessories**

Accessory	Part No.
<b>Batteries</b>	
High capacity (2200 mAh) NiCd (std.)	587-5100-220
Extra high capacity (3500 mAh) NiMH	587-5100-360
<b>Battery Chargers</b>	
Single-Unit rapid, 117 VAC enhanced	585-5000-230
Six-Unit rapid multi-charger, 117 VAC	585-5000-240
Wall mount kit for multi-charger	585-5000-250
<b>Antennas</b>	
806-870 MHz half-wave (white)	501-0105-013
Belt Clip, black 2.5"	585-5100-128
<b>Speaker/Microphones</b>	
Speaker/microphone, standard	589-0015-057
Speaker/microphone, with antenna	589-0015-058
<b>Programming Accessories</b>	
PCTrunk Portable Programming Kit (-453 software, -011 cable, manual)	250-5000-003
PCTrunk programming software, CD	023-9998-453
Replacement prog cable (cmptr-radio)	023-5000-011
Cloning cable (radio-to-radio)	023-5000-013
<b>Test Cables and Accessories</b>	
PCTune radio tuning software	023-5000-093
Radio Interface Box (RIB)	023-5000-095
Radio interface cable (RIB to radio)	023-5000-097
DB9 M-DB9 F cable, 6 ft. (RIB to cmptr)	597-5900-002
SMA F to BNC F adapter	515-3102-050
<b>Encryption Keyloader and Accessories</b>	
Key loader (T3011DX)	585-5000-930
Key loader to radio cable	585-5000-932
Key loader charger (NLN8858)	585-5000-934
Key loader spare battery (NLN9998)	585-5000-936

**Antennas** - The VHF and UHF antennas tuned for a specific frequency band have a color coded tip as indicated in Table 1-1.

**Encryption Options** - Transcrypt 460 scrambling is standard. This type of scrambling can be enabled and

programmed using the PCTrunk software as described Section 3. For more encryption information, refer to Section 2.4.13.

**Programming Cable** - This cable connects the transceiver to the computer when performing programming.

**Cloning Cable** - This cable connects two transceivers together when using one transceiver to program another. The function is selected from keypad programming as described in Section 2.9.3.

**Radio Interface Box (RIB)** - Provides a centralized control point for performing radio tests and evaluating radio performance. The Radio Interface Cable is required to connect this box to the transceiver. If the computer is connected to this box to allow simultaneous programming or tuning of the radio, a DB9M to DB9F adapter cable is required between the computer and RIB.

## 1.7 FACTORY CUSTOMER SERVICE

The Customer Service Department of the E.F. Johnson Company provides customer assistance on technical problems and the availability of local and factory repair facilities. Regular Customer Service hours are 7:30 AM. - 5:30 PM. Central Time, Monday - Friday. The Customer Service Department can be reached using one of the following telephone numbers:

**Toll-Free: (800) 328-3911**

(From within continental United States only)

**International: (507) 835-6911**

**FAX: (507) 835-6969**

**E-Mail: First Initial/Last Name@efjohnson.com**

(You need to know the name of the person you want to reach. Example: jsmith@efjohnson.com)

*NOTE: Emergency 24-hour technical support is also available at the 800 and preceding numbers during off hours, holidays, and weekends.*

When your call is answered at E.F. Johnson, you will hear a brief message informing you of numbers that can be entered to reach various departments. This number may be entered during or after the message

using a tone-type telephone. If you have a pulse-type telephone, wait until the message is finished and an operator will come on the line to assist you. When you enter some numbers, another number is requested to further categorize the type of information you need.

You may also contact the Customer Service Department by mail. Please include all information that may be helpful in solving your problem. The mailing address is as follows:

E.F. Johnson Company  
Customer Service Department  
299 Johnson Avenue  
P.O. Box 1249  
Waseca, MN 56093-0514

### 1.8 FACTORY RETURNS

Repair service is normally available through local authorized E.F. Johnson Land Mobile Radio Service Centers. If local service is not available, the equipment can be returned to the factory for repair. However, it is recommended that you contact the Customer Service Department before returning equipment because a service representative may be able to suggest a solution to the problem so that return of the equipment would not be necessary.

Be sure to fill out a Factory Repair Request Form #271 for each unit to be repaired, whether it is in or out of warranty. These forms are available free of charge by calling Customer Service (see Section 1.7) or by requesting them when you send a unit in for repair. Clearly describe the difficulty experienced in the space provided and also note any prior physical damage to the equipment. Then include a form in the shipping container with each unit. Your telephone number and contact name are important because there are times when the technicians have specific questions that need to be answered in order to completely identify and repair a problem.

When returning equipment for repair, it is also a good idea to use a PO number or some other reference

number on your paperwork in case you need to call the repair lab about your unit. These numbers are referenced on the repair order and it makes it easier and faster to locate your unit in the lab.

Return Authorization (RA) numbers are not necessary unless you have been given one by the Field Service Department. RA numbers are required for exchange units or if the Field Service Department wants to be aware of a specific problem. If you have been given an RA number, reference this number on the Factory Repair Request Form sent with the unit. The repair lab will then contact the Field Service Department when the unit arrives.

### 1.9 REPLACEMENT PARTS

Replacement parts can be ordered directly from the Service Parts Department. To order parts by phone, dial the toll-free number as described in Section 1.7. When ordering, please supply the part number and quantity of each part ordered. E.F. Johnson dealers also need to give their account number. If there is uncertainty about the part number, include the designator (C512, for example) and the model number of the equipment the part is from.

You may also send your order by mail or FAX. The mailing address is as follows and the FAX number is shown in Section 1.7.

E.F. Johnson Company  
Service Parts Department  
299 Johnson Avenue  
P.O. Box 1249  
Waseca, MN 56093-0514

### 1.10 INTERNET HOME PAGE

E.F. Johnson has a site on the World Wide Web that can be accessed for information on the company and such things as products, systems, and regulations. The address is <http://www.efjohnson.com>.

## 5100 SERIES PORTABLE SPECIFICATIONS

The following are general specifications intended for use in testing and servicing this transceiver. For current advertised specifications, refer to the specification sheet available from your sales representative. Values are typical and are subject to change without notice.

### GENERAL

Frequency Range	800 MHz 806-870 MHz
Operating Modes	Project 25 conv. and trunked, SMARTNET, SmartZone, Conventional analog, Multi-Net
Zones/Channels	16 zones with 16 channels per zone
Transmit/Receive Separation	Any frequency within the range
Channel Spacing	800 MHz: 12.5 and 25 kHz
Maximum Deviation	25 kHz analog - 5 kHz 12.5 kHz analog NPSPAC - 4.0 kHz
Frequency Stability	1.5 PPM -22° to +140° F (-30° to +60° C)
Dimensions (w/o antenna)	6.7" H x 2.52" W x 1.9" D (17.0 cm x 6.4 cm x 4.8 cm)
Weight (w/std battery)	24 oz. (675 g)
Supply Voltage	7.5 volts DC nominal
Battery Life	13 hours typical w/std 3300 mAH NiMH battery
Current Drain (maximum)	Standby - 110 mA Receive (rated audio out) - 350 mA Low Tx Power - 1.2 A High Tx Power - 2.6 A (800 MHz)

### RECEIVER

Sensitivity	0.35 $\mu$ V (analog mode 12 dB SINAD), 0.35 $\mu$ V (digital mode 5% BER)
Selectivity	60 dB
Spurious and Image Rejection	65 dB
Intermodulation	70 dB
Hum and Noise	40 dB at 25 kHz, 34 dB at 12.5 kHz
Maximum Frequency Spread	Any spread within the range
Audio Power Output	500 mW
Audio Distortion	Less than 5% at 1 kHz

### TRANSMITTER

RF Power Output	800W: 3W
Spurious and Harmonic Emissions	60 dB
FM Hum and Noise	40 dB at 25 kHz bandwidth
Audio Modulation	14K0F3E, 16K0F3E, 8K10F1E
Audio Distortion	Less than 3% at 1 kHz
Maximum Frequency Spread	Any spread within the band

## SECTION 2 OPERATION

### 2.1 FEATURES

#### 2.1.1 GENERAL FEATURES

- Programmable for the following modes of operation:
  - Conventional analog
  - Conventional Project 25 (digital)
  - SMARTNET™/SmartZone® trunked (analog or digital)
- Up to 16 zones with up to 16 channels each programmable (256 channels total)
- Liquid crystal display (LCD) with backlight
- Ten programmable option switches (full keypad model)
- Standard and radio-wide scan modes
- Time-out timer
- Power-up password access available to prevent unauthorized usage

#### 2.1.2 CONVENTIONAL FEATURES

- Up to 256 channels or talk groups programmable
- Repeater talk-around
- Monitor mode selected by option switch
- Carrier or Call Guard® controlled squelch on analog channels
- Penalty and conversation timers
- Priority channel sampling when scanning
- Busy channel lockout (transmit disable on busy)
- 460 secure communication available on analog channels, DES-OFB on Project 25 channels
- Individual ID calls on Project 25 channels
- User selectable high and low power output
- Emergency switch
- Keypad programming

#### 2.1.3 SMARTNET/SMARTZONE FEATURES

- Up to 256 talk groups programmable
- Group, Enhanced Private Conversation™, Private Conversation II™, and Telephone Calls

- Emergency alarms to alert dispatcher of emergency conditions
- Emergency calls for high priority system access
- Failsoft operation on a predefined conventional channel if trunked system fails
- Priority group calls detected while listening to other group calls
- Call Alert™ (send and receive pages)
- Predefined messages (up to 16) can be sent to a dispatcher
- Predefined status conditions (up to 8) can be sent to a dispatcher
- Dynamic regrouping (dispatcher can automatically gather users on a channel to receive a message)
- Roaming (SmartZone only)
- SecureNet™ or 460 secure communication available

*NOTE: The availability of many of the preceding features is controlled by system operator programming of your transceiver, installed options, and the capabilities of the radio system being accessed.*

### 2.2 OPTION SWITCH FUNCTIONS

The programmable option switches are as follows:

- The F1, F2, F3, and F4 keys on the front panel
- The three push-button switches on the side
- The 3-position toggle switch on the top panel
- The # key on the front panel (full keypad models only)

These switches can control one function when a conventional channel is selected and another when a SMARTNET/SmartZone channel is selected. The available functions for each operating mode and the page on which each function is described are listed in the following tables. Refer to Section 2.4.5 for more option switch information.

Table 2-1: Programmable Option Switch Functions

CONVENTIONAL MODE		SMARTNET/SmartZone Mode	
Function	See Section:	Function	See Section:
Backlight	2.4.4	Backlight	2.4.4
Clear/Secure	2.4.13	Call Alert	2.7.7
Displayed Information	2.6.2	Call Response	2.7.4, 2.7.5
High/Low Power	2.6.10	Clear/Secure	2.4.13
Home Zone	2.4.9	Home Zone	2.4.9
Individual ID Call	2.6.16	Keypad Lock	2.4.6
Keypad Lock	2.4.6	Message	2.7.8
Keypad Programming	2.9	Phone	2.7.6
Monitor	2.6.4	Private Call	2.7.4, 2.7.5
Normal/Selective	2.6.6	Radio Wide Scan	2.5.3
Priority	2.6.13	Reverse Top Display	2.3.4
Radio Wide Scan	2.5.3	Scan	2.5.2
Repeater Talk-Around	2.6.9	Scan Edit	2.5.9
Reverse Top Display	2.3.4	Site Lock (SmartZone only)	2.7.14
Scan	2.5.2	Site Search (SmartZone only)	2.7.14
Scan Edit	2.5.9	Status	2.7.9
Talk Group Select	2.6.16	Tones On-Off	2.4.11
Tones On-Off	2.4.11	Zone Select	2.4.8
Zone Select	2.4.8		

## 2.3 CONTROLS AND DISPLAY

### 2.3.1 FRONT PANEL CONTROLS

**Speaker** - The transceiver speaker is located behind this grill. When a speaker/microphone is used, this speaker is automatically disabled.

**Microphone** - The microphone is located in this area. For best results, hold the transceiver 2-3 inches from your mouth and speak at a normal conversational level.

**Front Display** - This is an 8-character, 14-segment LCD (Liquid Crystal Display). This display backlight can be programmed to turn on when any key is pressed or when the Backlight option switch is pressed (see Section 2.4.4). This display also contains nine status indicators which are described in Section 2.3.4.

**DTMF Keypad** - The full keypad, 18-key models include the keys required to dial telephone, unit ID, and group ID numbers and also to enter numbers for keypad programming.

**F1 - F4** - These keys are available with both full and limited keypad models, and they can be system operator programmed to control a specific function. The key functions can be different for each operating mode (see Section 2.2). In addition, there are keys used for scrolling up or down in menus ( ▼ ▲ ) and entering (**ENT**) and clearing (**CLR**) information. Other programmable option switches are located on the top and side panels (see preceding information).



**Figure 2-1 Front Panel Controls**

### 2.3.2 TOP PANEL CONTROLS

**Two-Color Indicator** - Indicates the following conditions:

Steady Red - Transmitter keyed, normal power.

Flashing Red - Transmitter keyed, low battery (the low power mode is automatically selected).

Steady Green - Carrier detected in receive mode.

Flashing Green - Low battery in receive mode. In addition, when scanning, it flashes when the priority channel is scanned while receiving a message on a non-priority channel.

**Option Switch** - This is a three-position toggle switch that can be system operator programmed to control some function (see Section 2.2).

**On-Off/Volume** - Turning the knob clockwise turns power on and sets the volume level. Turning it counterclockwise to the detent turns power off.

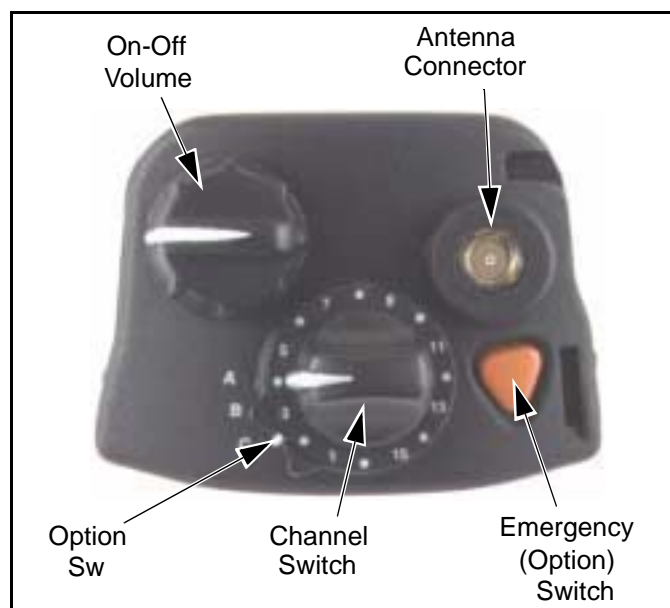

**Figure 2-2 Top Panel Controls**

**Channel Switch** - This 16-position switch allows up to 16 channels to be selected. This switch operates in conjunction with up to 16 programmable zones to allow up to 256 channels to be selected.

**Antenna Connector** - Connection point for the antenna. Make sure that the antenna is tight before using the radio.

**Emergency Switch** - If the radio is programmed for emergency transmissions, pressing this switch alerts a dispatcher, for example, of an emergency condition. Refer to descriptions in Sections 2.6.11 and 2.7.10 for more information.

### 2.3.3 SIDE CONTROLS

**Option Switches 1, 2, and 3** - These switches can be system operator programmed to control a specific function (see Section 2.2).

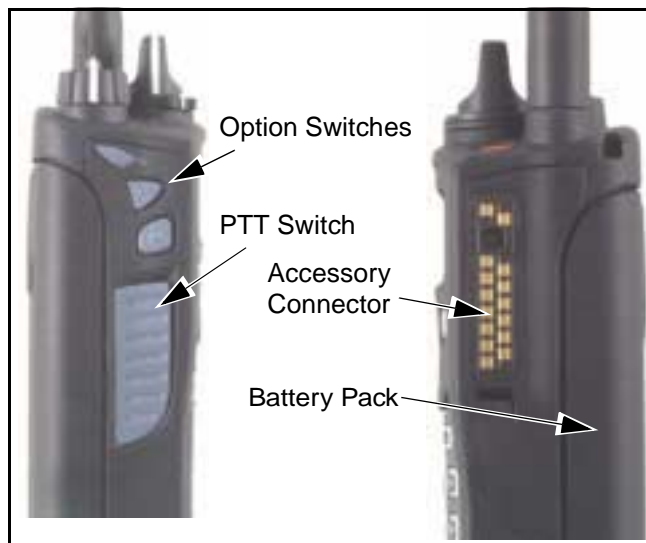

**PTT Switch** - This switch is pressed to turn the transmitter on. The indicator on the top panel lights red when the transmitter is keyed.

**Battery** - To remove the battery, press the release on the bottom toward the front of the transceiver and slide the battery outward.

**Accessory Connector** - Connection point for optional accessories such as a speaker/microphone.

### 2.3.4 DISPLAY

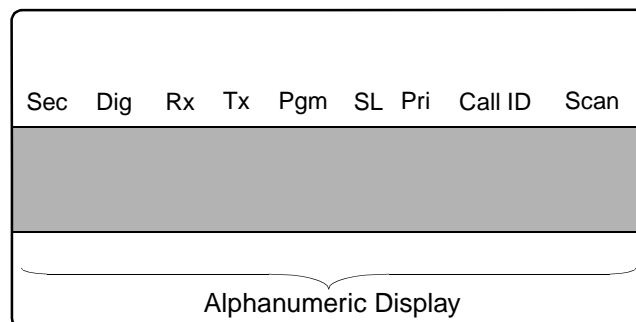

The front panel display is shown above. In the conventional mode, if the Display Information option switch is programmed, either the channel number, channel name, or frequency can be selected (see Section 2.6.2).

The following information is indicated in the display:

**Alphanumeric Characters** - These eight characters indicate the selected channel, error conditions, and other information.

**Sec** - Indicates that transmissions are encrypted (see Section 2.4.13).

**Dig** - Indicates that a digital (Project 25) conventional channel is selected.

**Rx** - Indicates that a carrier is being detected on the selected or scanned channel. This indication is displayed in conjunction with a green LED on the top panel (see Section 2.3.2).

**Tx** - Indicates the transmitter is keyed. This indication is displayed in conjunction with a red LED on the top panel.

**Pgm** - Indicates that the keypad programming mode is selected (see Section 2.9).

**SL** - Indicates that the displayed channel is in the scan list (see Section 2.5.7).

**Pri** - Indicates that the displayed channel is programmed as the current group's priority channel (see Section 2.6.13).



**Call ID** - Indicates that the display is showing the ID of the calling party (see Section 2.7.4).

**Scan** - Indicates that system scan is activated (see Section 2.5).

## 2.4 GENERAL OPERATION

### 2.4.1 INTRODUCTION

The following section describes features available with both trunked and conventional operation. Features unique to conventional channels are described in Section 2.6, and features unique to SMARTNET/SmartZone channels are described in Section 2.7.

### 2.4.2 TURNING POWER ON AND SETTING VOLUME

Power is turned on and off by the On-Off/Volume switch on the top panel. When power is initially turned on, an alert tone sounds and the indicator on the top panel flashes green. If a SMARTNET/SmartZone channel is selected, the zone alias is then displayed followed by the unit ID (see Section 2.7.2). The selected channel is then indicated.

To turn power off, turn the On-Off/Volume knob counterclockwise until a click occurs. The display may remain on for a few seconds after power is turned off. It is recommended that power not be turned back on again until the display is blank.

The relative volume level can be determined by noting the position of the index on the On-Off/Volume knob. To enable a reference tone for setting the volume, proceed as follows:

- If key press tones are enabled (see Section 2.4.11), a short tone sounds when front panel keys are pressed.
- If a conventional channel is selected and the Monitor option switch is programmed (see Section 2.6.4), pressing that switch un-squelches/squelches the receiver and either voice or background noise is heard. If a SMARTNET/SmartZone channel is selected, the receiver cannot be manually un-squelched.

### 2.4.3 POWER-UP PASSWORD

#### General

The power-up password feature prevents unauthorized use of the transceiver. When it is enabled by system operator programming, an eight-digit password must be entered to make the transceiver operational each time power is turned on. Passwords can be entered even if the keypad is locked (see Section 2.4.6). The default password is eight zeros (00000000). Refer to Section 3.7 for more information on passwords.

If this feature is enabled, proceed as follows to unlock the radio:

1. Turn radio power on and when “LOCKED” is displayed, enter the eight-digit numeric password using the keypad. As each digit is entered, a dash is displayed. If an incorrect digit is entered, press the **CLR** key and re-enter the entire password.
2. When all eight digits have been entered, press the **ENT** key. If the password is correct, the display indicates normal zone and then channel information. If an incorrect password is entered, “LOCKED” is again displayed.

#### Changing Password

The current password can be changed as follows:

1. The locked mode must be selected to change the password, so cycle power if necessary to display “LOCKED”.
2. Enter the old eight-digit password and press the **#** key (not **ENT**). If the correct password is entered, “NEW PSWD” is displayed.
3. Enter the new password and press **ENT**. The password is changed.

### 2.4.4 BACKLIGHT

The backlight for the display and keypad can be manually turned on by pressing the Backlight option switch if it is available. The backlight can also be system operator programmed to automatically turn on

when any key is pressed. It then automatically turns off after a programmed delay so that battery drain is minimized.

#### 2.4.5 OPTION SWITCHES

The programmable option switches are as follows:

- **F1, F2, F3, and F4** on front panel. In addition, with full keypad (18-key) models, the **#** key is programmable (see Figure 2-1).
- The two push-button switches on the side panel (see illustration in Section 2.3.3).
- The 3-position toggle switch on the top panel (see Figure 2-2).

If your radio is programmed with both conventional and SMARTNET/SmartZone channels (see Section 2.4.12), these option switches can be system operator programmed to control a different set of functions for each channel type. For example, the **F1** switch could select Hi/Lo Power when a conventional channel is selected and Private Calls when a SMARTNET/SmartZone channel is selected. The available functions in each mode are indicated in the tables in Section 2.2. If no option switch has been programmed to control a particular function, that function may not be available or may be in a fixed mode.

#### 2.4.6 KEYPAD LOCK

If the Keypad Lock option switch has been programmed, the keypad can be locked (disabled) to prevent keys from being accidentally pressed. To lock the keypad, simply press this switch. Then to unlock it again, press and hold it until a tone sounds. The keypad can also be disabled by system operator programming. It is then permanently disabled and cannot be re-enabled by the user.

#### 2.4.7 LOW BATTERY INDICATION

When the battery voltage falls below a preset level, the radio can be programmed so that any or all of the following indications occur:

- The indicator on the top panel flashes red in the transmit mode and green in the receive mode.
- A chirp sounds every 5 seconds in the receive mode.
- A chirp sounds every 5 seconds in the transmit mode.

The battery should be recharged as soon as practical after a low battery indication appears.

#### 2.4.8 CHANNEL AND ZONE SELECTION

##### Channel Select

To change the current channel, rotate the 16-position channel selector knob on the top panel to the desired position. With SMARTNET/SmartZone channels, the selected channel is always indicated by an alias (name). The alias is also displayed with conventional channels if the Display Mode option switch is not programmed. If this switch is programmed, the channel number or frequency may also be displayed (see Section 2.6.2).

##### Zone Select

A zone is a group of up to any 16 conventional and SMARTNET/SmartZone channels defined by system operator programming. Up to 16 zones can be programmed for a total of 16 x 16 channels per zone or 256 channels. One use of zones may be to select groups of channels programmed for operation in different geographical areas or radio systems. If selectable zones have been programmed in your radio, consult your system operator for more information on how they are used. Zones are selected as follows:

1. Press the Zone option switch and the alias (name) of the current zone is flashed in the display.
2. Use the number keys to enter the desired zone number or scroll through the available zones using the ▼ and ▲ keys.
3. When the desired zone is displayed or entered, select it by pressing the **ENT** key or waiting 4 seconds.

### 2.4.9 HOME ZONE

The radio can be programmed with a home zone. Then when power is turned on, the radio can be programmed so that either the home or last selected zone is automatically selected.

If the Home Zone option switch is programmed, it can be used to quickly select or change the home zone. To select the home zone, simply press this switch. To change the home zone to the currently selected zone, press and hold this switch until a tone sounds (approximately 1 second).

### 2.4.10 TIME-OUT TIMER

The time-out timer disables the transmitter if it is keyed for longer than the programmed time. It can be programmed on each channel for times of 15 - 225 seconds or it can be disabled (not used). If the transmitter is keyed continuously for longer than the programmed time, the transmitter is disabled and an invalid condition tone sounds. Five seconds before time-out occurs, an alert tone sounds to indicate that time-out is approaching. The timer and tone are reset by releasing the PTT switch.

One use of this feature is to prevent a channel from being kept busy for an extended period by an accidentally keyed transmitter. It can also prevent possible transmitter damage caused by transmitting for an excessively long period. Conventional channels can also be programmed with the Penalty and Conversation timers that are described in Sections 2.6.7 and 2.6.8.

### 2.4.11 TONE ENABLE/DISABLE

The supervisory tones (see Section 2.8) can be enabled and disabled by the Tones On-Off option switch if it is programmed. When tones are enabled by this switch, "TONE ON" is momentarily displayed and a tone sounds. Conversely, when tones are disabled, "TONE OFF" is displayed and no tone sounds. If the Tones On-Off option switch is not programmed, tones are fixed in the on or off mode by programming.

### 2.4.12 TRANSCEIVER OPERATING MODES

#### Introduction

Each selectable channel can be programmed for either the conventional or SMARTNET/SmartZone operating mode. For example, Zone 1/Channel 1 could be a conventional channel, Zone 1/Channel 2 a SMARTNET channel, and so on. More information on these modes follows.

#### Conventional Mode

This is a non-trunked operating mode which accesses independent radio channels (there is no automatic access to several channels). Monitoring before transmitting may not be automatic in this mode, so you may need to manually monitor the channel before transmitting to make sure that it is not in use. Either analog or digital (Project 25) signaling may be used. When a digital channel is selected, "DIG" is indicated in the upper part of the display. Channel monitoring and other operating features unique to conventional channels are described starting with Section 2.6.1.

#### SMARTNET™/SmartZone® Mode

This is a trunked operating mode that uses ID codes to select what mobiles are being called and what calls are received. Monitoring is performed automatically and special messages and tones indicate busy and out-of-range conditions. Enhanced features include roaming (SmartZone only), telephone, private, and emergency calls, Call Alert™, and messaging. Either analog or digital signaling may be used. When a digital channel is selected, "Dig" is indicated in the upper part of the display. Operating features unique to SMARTNET/SmartZone channels are described starting with Section 2.7.1.

When a SMARTNET or SmartZone channel is selected or the radio is powered up on one of those channels, it searches for a control channel and attempts to register on the radio system. Once a control channel is found, the alias (name) of the selected channel is displayed. If a control channel could not be found (because of an out of range condition or the system ID is not correct, for example), "NO SYS" is displayed and the radio continues to search for a control channel.

The control channel transmits and receives system information to and from all radios registered on the system. Therefore, once a control channel is found, it is continuously monitored for incoming call information and is used to make call requests. The radio automatically changes to a traffic channel to place and receive calls and then returns to the control channel when the call is complete.

### 2.4.13 SECURE COMMUNICATION

This transceiver may be optionally equipped to provide secure communication on some or all channels. This feature encrypts your voice so that it can be understood only by someone using a transceiver equipped with a similar encryption device and encryption codes.

When a secure call is received or transmitted, “**Sec**” is indicated in the upper part of the display. Secure communication can be programmed on a per channel basis to operate in various ways. If equipped with the Clear/Secure option switch and the current channel is programmed to allow switch selection, secure communication can be manually enabled and disabled by that switch. Secure communication can be programmed on a per channel basis to operate in various ways. Refer to Sections 2.6.17 and 2.7.15 for more information.

## 2.5 SCANNING

### 2.5.1 INTRODUCTION

Scanning cycles through a list of channels called a “scan list”, checking each for messages. When a message is detected that your transceiver is programmed to receive, scanning stops and the message is received. Shortly after the message is complete, scanning resumes (unless it has been disabled).

There are two basic scan modes: Standard and Radio Wide. The Standard mode is unique to the type of channel selected (conventional or SMARTNET/SmartZone), and the Radio Wide mode is the same regardless of the channel type selected. Only one of these scan modes can be enabled at a time. Therefore, if standard scanning is enabled while radio wide scanning is occurring, radio wide scanning is automatically

disabled and vice versa. More information on these modes follows.

### 2.5.2 STANDARD SCANNING

Standard scanning monitors only channels that are the same type as that currently selected. Therefore, if a conventional channel is selected, only conventional channels are scanned, and if a SMARTNET channel is selected, only SMARTNET channels are scanned. Standard scanning is turned on and off by the Scan option switch as follows. If this switch is not programmed, standard scanning is not available.

- To turn standard scanning on, press the Scan option switch. Scanning is enabled when the “**Scan**” icon is indicated in the upper right corner of the front panel display and “SCAN ON” is briefly displayed.
- To turn scanning off, press the Scan option switch again. The “**Scan**” icon is then no longer indicated and “SCAN OFF” is briefly displayed.
- If the zone or channel is changed while scanning is selected, scanning continues on the same or a different scan list (see scan list information which follows).

### 2.5.3 RADIO WIDE SCANNING

Radio wide scanning monitors the channels in the preprogrammed radio wide scan list (see Section 2.5.5). This list may contain up to 16 channels of any type (conventional or SMARTNET/SmartZone) assigned to any zone. Radio wide scanning is turned on and off by the Radio Wide Scan option switch as follows. If this switch is not programmed, radio wide scanning is not available.

- To turn radio wide scanning on, press the Radio Wide Scan option switch. Scanning is enabled when “**Scan**” is indicated in the upper right corner of the front panel display and “SCAN ON” is briefly displayed.
- To turn radio wide scanning off, press the Radio Wide Scan option switch again. The “**Scan**” icon is then no longer indicated and “SCAN OFF” is briefly displayed.

- If the zone or channel is changed while radio wide scanning, scanning continues normally.

#### 2.5.4 SCAN RESUME DELAY

When a message is received or transmitted while scanning, there is a system operator programmable delay before scanning resumes. The delay after receiving a call prevents another message from being received before you can make a response, and the delay after transmitting a call ensures that you hear a response to your call instead of another message occurring on some other channel.

#### 2.5.5 STANDARD MODE SCAN LIST

*NOTE: The selected channel is always scanned.*

With conventional operation, up to three scan lists can be programmed. The list that is scanned is selected by the Scan option switch as described in Section 2.6.12. Selecting another conventional channel does not change the current scan list. The scan lists are user programmable if the Scan Edit option switch is programmed (see Section 2.5.9).

With SMARTNET/SmartZone operation, each channel can be programmed so that one of up to three different scan lists is automatically selected or scanning is disabled. The scan list assigned to the current channel is not user selectable, but it is user programmable if the Scan Edit option switch is programmed (see Section 2.5.9).

#### 2.5.6 RADIO WIDE MODE SCAN LIST

With radio wide scanning, there is only one preprogrammed scan list available regardless of the type of channel selected, and it is not user programmable.

#### 2.5.7 DETERMINING WHICH CHANNELS ARE IN SCAN LIST

Channels in the standard SMARTNET/SmartZone and radio wide lists are not indicated. With conventional channels, the selected channel is in the current scan list if “**SL**” (Scan List) is indicated in the upper part of the display.

#### 2.5.8 NUISANCE CHANNEL DELETE

With standard scanning, channels can be temporarily deleted from the scan list, for example, if messages on a channel become annoying. This feature is not available with radio wide scanning. Proceed as follows:

*NOTE: The selected channel and conventional priority channels cannot be deleted from the scan list.*

1. While receiving a message on the channel to be deleted, press and hold the Scan option switch until the alert tone sounds (about 1 second).
2. The channel is then deleted and scanning of the remaining channels in the scan list resumes.
3. Deleted channels are added back into the scan list if any of the following events occur:
  - Scanning is turned off and then on again using the Scan switch.
  - Transceiver power is turned off and then on again.
  - The scan list is reselected by pressing the number key corresponding to the list number (conventional) or by selecting another channel (SMARTNET/SmartZone).
  - Another channel is selected by the top panel channel switch.

#### 2.5.9 PROGRAMMING A SCAN LIST

When full keypad (18-key) models, conventional and SMARTNET/SmartZone standard scan lists are user programmable if the Scan Edit option switch is programmed and user programming of the list is allowed. Scan list programming is not available with limited keypad (6-key) models. Proceed as follows to program a scan list:

##### Preliminary

1. With conventional channels, select the list to be edited (1-3) by pressing the key corresponding to the desired list number with scanning enabled (see Section 2.6.12). If a list is not selected, the last active scan list is automatically edited. With SMARTNET/SmartZone channels, the scan list for

the selected channel is fixed and cannot be changed. Scanning may also be disabled on some channels.

2. If scanning is enabled, turn it off by pressing the Scan option switch.
3. Press the Scan Edit option switch. The alias of the first channel in the scan list is displayed. If scan list programming or scanning is disabled on the selected list or channel, "NO LIST" is momentarily displayed and scan list programming is not available. Proceed as follows to delete or add a channel:

#### To Delete a Channel:

4. Select the channel you want to delete by pressing the ▼ and ▲ keys.
5. With conventional channels, to delete the displayed channel and exit this mode, press the **CLR (F3)** key. With SMARTNET/SmartZone channels, press the "2" key and then **ENT (F4)**.

*NOTE: The priority channel cannot be deleted (see Section 2.6.13).*

#### To Add a Channel:

1. Press the Scan Edit option switch. The alias of the first channel in the scan list is displayed.
2. Enter the two-digit zone and channel number of the channel you want to add. For example, to add Zone 1/Channel 5, enter "0105". Refer to Section 2.4.8 for more information on zones and channels.
3. With conventional channels, to add the channel to the scan list and exit this mode, press the **ENT (F4)**. With SMARTNET/SmartZone channels, press the "1" key and then **ENT (F4)**.

## 2.6 CONVENTIONAL FEATURES

### 2.6.1 INTRODUCTION

The following information describes features unique to the conventional operating mode (see brief description in Section 2.4.12). Refer to Section 2.4 for information on features common to all operating

modes, and to Section 2.7 for information on features unique to the SMARTNET/SmartZone mode.

### 2.6.2 DISPLAY MODE SELECTION

If the Displayed Information option switch is programmed, it is usually the three-position toggle switch on the top panel. This switch selects the following conventional channel display modes. If this switch is not programmed or a SMARTNET/SmartZone channel is selected, the Alias mode is always used.

**Alias** - The preprogrammed alphanumeric tag for the channel is displayed.

**Number** - The channel number from 1-16 is displayed as "CHAN xx".

**Frequency** - The frequency of the selected channel is displayed in megahertz. The transmit frequency is displayed in the transmit mode and the receive frequency is displayed in the receive mode.

*NOTE: The channel number can also be determined by noting the number (1-16) indicated by the index on the channel selector knob.*

### 2.6.3 MONITORING BEFORE TRANSMITTING

With conventional operation, you may need to manually monitor the channel before transmitting to make sure that it is not being used by someone else. If you were to transmit while someone else was using the channel, you would probably disrupt their conversation. Channels are monitored automatically or manually as follows:

#### Automatic Channel Monitoring

If the selected channel is programmed for Busy Channel Lockout feature (consult your system operator), monitoring is performed automatically. Refer to the description of this feature in Section 2.6.5 for more information.

#### Manual Channel Monitoring

The automatic monitoring just described may not be programmed or it may occasionally disable the

transmitter even if the channel is not in use. In this case, the channel must be monitored manually as follows:

**Rx Indicator** - With scanning disabled, note if the indicator on the top panel is steady green. If it is not, the channel is not being used and you can transmit your call. If it is green, the channel may be busy and you should not place your call (see next paragraph).

**Monitor Mode** - There may be times when the busy indication is displayed even though no one is using the channel. Monitoring should then be performed by disabling Call Guard squelch using the Normal/Selective option switch as described in Section 2.6.6 or the monitor mode described next.

## 2.6.4 MONITOR MODE

The monitor mode temporarily disables squelch control features (such as Call Guard<sup>®</sup> squelch) so that all messages are heard on the selected channel. It also overrides the Busy Channel Lockout feature (see next section) and temporarily halts scanning.

To monitor the selected channel, select the monitor mode by briefly pressing or pressing and holding the Monitor option switch (if available). The receiver unsquelches and a rushing noise or voice is heard when the monitor mode is enabled. To disable the monitor mode and return to normal operation, release the Monitor switch or press it a second time.

If scanning is enabled, pressing and holding the Monitor option switch monitors the current scanned channel instead of the selected channel if applicable.

## 2.6.5 BUSY CHANNEL LOCKOUT

The Busy Channel Lockout feature (also called Transmit Disable On Busy) automatically disables the transmitter if the channel is busy when the PTT switch is pressed. When a busy condition is detected by this feature, the transmitter is disabled, "BUSY" is indicated in the display, and a tone similar to a standard telephone busy tone sounds until the PTT switch is released. The transceiver can be programmed to operate in one of the following modes on each channel:

**Off** - Busy channel lockout is disabled and the transmitter keys even if the channel is busy.

**Noise** - The transmitter is disabled if a carrier is detected on the channel.

**Tone** - The transmitter is disabled if an incorrect Call Guard (CTCSS/DCS) or NAC code is detected (see Section 2.6.6). An incorrect code is any code other than the one programmed for the current channel.

If busy override is permitted by programming, it is possible to transmit even when the transmitter is disabled by this feature. Simply release the PTT switch and then quickly press it again.

## 2.6.6 CALL GUARD SQUELCH

### Introduction

Tone or digital Call Guard squelch (also called CTCSS/DCS signaling) can be programmed on each conventional analog transmit and receive channel in any order desired. The reverse burst and turn-off code are always transmitted and also detected on channels programmed with Call Guard squelch.

The Call Guard squelch feature eliminates distracting messages intended for others using the channel. This is done by using a subaudible tone or digital code to control the squelch. This tone or code is unique to a user or a group on that channel. This tone or code is transmitted with the voice signal but is not heard because it is in the subaudible range and is attenuated by a filter. Call Guard squelch must be used in both the transmitting and receiving transceiver to be functional.

### Call Guard Squelch Enable/Disable

To disable Call Guard (Selective) squelch so that all messages on the selected or scanned channels are heard, press the Normal/Selective option switch (if available) so that "NORMAL" is flashed in the display. Then to re-enable Call Guard squelch, press the Normal/Selective switch again so that "SELECTIV" is flashed. The mode selected by this switch does not change when other channels are selected or power is cycled. Call Guard squelch can also be disabled by the monitor mode described in Section 2.6.4.

### Tone Call Guard Squelch

Tone-type Call Guard squelch utilizes subaudible CTCSS tones from 67-254.1 Hz. Although there are 42 tones assigned, those above 33 (210.7 Hz) are normally not used because of their close proximity to the voice band which starts at 300 Hz. In addition, tones 11 (97.4 Hz), 39 (69.3 Hz), 40 (206.5 Hz), 41 (229.1 Hz), and 42 (254.1 Hz) are normally not used because they may cause interference with adjacent tones.

A reverse burst is transmitted when the push-to-talk switch is released and also detected when calls are received. It is a 180-degree phase reversal for a period of time determined by the tone frequency, and it eliminates the squelch tail (noise burst) in the receiving transceiver. Both the transmitting and receiving transceiver must be equipped with this feature for it to be utilized.

### Digital Call Guard Squelch

Digital Call Guard squelch (CDCSS) uses digital data instead of subaudible tones to control the squelch. This data consists of continuous repetitions of 23-bit words. No bit or word synchronization information is used. When the push-to-talk switch is released, a turn-off code is transmitted which eliminates the squelch tail similar to the reverse burst.

Although there are thousands of possible code combinations with 23 bits, only 83 are unique with the data scheme used. The number specified when the code is programmed is actually a seed for a special algorithm used to generate the 23-bit data word. The data is transmitted at a rate of 134.4 bits per second. Therefore, approximately six words are transmitted each second. When the data is decoded, 23-bit samples are taken and then the bits are rotated to determine if a valid code was received.

### Keypad Selectable Call Guard Code (CTCSS/DCS)

If you have the full keypad (18-key) model and the ability to change Call Guard codes has been enabled by programming, the transmit and receive codes from one channel can be temporarily or permanently reassigned to all channels of the current zone. Proceed as follows:

1. Using the number keys, enter the number of the channel that is programmed with the code you want to reassign to all channels (only channels 1-9 can be selected). See Section 2.6.2 for information on displaying channel numbers.
2. The display then briefly indicates "CODE x", where "x" is the key you pressed. The codes assigned to that channel are then reassigned to all the other channels in the current zone. The reassignments remain in effect even after power is cycled.
3. To restore all Call Guard codes in the current zone to the original settings, press the "0" key.

*NOTE: Keypad programming described in Section 2.9 can be used to change the Call Guard code of individual channels.*

### 2.6.7 PENALTY TIMER

A penalty timer may be programmed on conventional channels to prevent transmissions for 15 - 225 seconds after the time-out timer described in Section 2.4.10 disables the transmitter. The penalty timer starts when the PTT switch is released after the transmitter has been disabled. If the PTT switch is pressed during the penalty time, the time-out indication occurs again. A beep sounds when the penalty timer expires and the transmitter can then be keyed.

### 2.6.8 CONVERSATION TIMER

A conversation timer can be programmed on conventional channels to limit the total length of a conversation rather than just the length of each transmission as with the time-out timer. This timer can be programmed for 0.5 - 7.5 minutes, and it is reset when the time between transmissions exceeds the penalty time just described. A warning tone sounds 5 seconds before the conversation timer expires. When it expires, the transmitter is disabled and a warning tone sounds. The transmitter remains disabled for the length of the penalty time, and a beep sounds when it can be keyed again.

### 2.6.9 REPEATER TALK-AROUND

Normally, all your transmissions go through a repeater which usually increases range. However, if



you are out of range of the repeater, you cannot talk to anyone else on that channel even though the mobile you are calling may be only a short distance away. To allow communication when this situation occurs, repeater talk-around can be used to allow direct communication with a mobile without going through a repeater.

Repeater talk-around can be selected if the Repeater Talk-Around option switch (if available). When talk-around is enabled by this switch, "RTA ON" is flashed in the display. Then when it is disabled by pressing the switch again, "RTA OFF" is flashed. Changing channels or turning power off does not change the selected talk-around mode.

### 2.6.10 POWER OUTPUT SELECT

If the High/Low Power option switch is programmed and power selection is permitted on the current channel, either high or low transmitter power can be selected. Generally, the high power setting allows you to transmit longer distances but uses more battery power, and the opposite occurs with the low power setting.

Pressing the High/Low Power switch toggles the power setting. The new level is flashed in the display when this switch is pressed as "HI POWER" or "LO POWER". If power selection is not permitted on the channel, the fixed power level is flashed and no power change occurs. Turning power off or changing channels does not change the power setting selected for a channel. Selectable power is not available with 800 MHz models.

### 2.6.11 EMERGENCY MODE (CONVENTIONAL)

On conventional channels, an emergency mode may be programmed to be selectable by the Emergency switch located next to the antenna (see illustration in Section 2.3.2). Scanning is automatically disabled in the emergency mode, so transmissions occur on the selected channel.

If an analog channel is selected and scrambling is programmed, pressing the Emergency switch sends an emergency signal on the selected channel 20 times or until an acknowledgment is received. Keying the radio also cancels the emergency condition.

If a Project 25 (digital) channel is selected, pressing this switch selects the emergency mode and if the PTT switch is pressed, an emergency status is sent. Radio power must be turned off to cancel the emergency mode on a Project 25 channel.

### 2.6.12 CONVENTIONAL MODE SCANNING

#### General

The following information describes scanning features unique to conventional operation. Scan operation common to all modes is described in Section 2.5, and scan operation unique to SMARTNET/SmartZone operation is described in Section 2.7.12.

#### Selecting a Scan List

With full keypad (18-key) models, one of up to three scan lists can be selected when scanning with a conventional channel selected. These lists can be system operator or user programmed as described in the information which follows. With limited keypad (6-key) models, only one scan list is available and it cannot be user programmed. However, nuisance channels can still be temporarily deleted as described on Section 2.5.8.

Proceed as follows to select a scan list with full keypad models:

1. If required, enable scanning by pressing the Scan option switch.
2. To select a list, press the number key corresponding to the number of the desired list (1-3). The selected list is then briefly displayed as "Scan x" where "x" is the list number. The selected scan list is stored in memory and does not change until this procedure is repeated.

#### Transmitting in Scan Mode

Each conventional scan list can be programmed for one of the following modes. These modes determine if priority sampling occurs and also the channel on which transmissions occur while scanning. Refer to the next section for more information.

**No Priority** - No priority channel sampling occurs when the list is selected. The radio transmits on the selected channel.

**Priority/Tx Priority** - Priority sampling occurs and the priority channel is the one programmed in the selected scan list. The radio transmits on the priority channel.

**Priority/Tx Selected** - Priority sampling occurs and the priority channel is the one programmed in the selected scan list. The radio transmits on the selected channel.

**Priority on Selected** - The priority channel is always the selected channel. The radio transmits on the selected channel.

**Talkback** - No priority sampling occurs. The radio transmits on the channel of a call while scanning is halted. Then once scanning resumes, it transmits on the selected channel.

## 2.6.13 PRIORITY CHANNEL SAMPLING

### General

The priority channel sampling feature ensures that when standard scanning is occurring, messages on the priority channel are not missed while listening to a message on some other channel. Your transceiver can be programmed so that the priority channel is a fixed channel associated with the current scan list, the currently selected channel, or not used. When the selected channel is a priority channel, “**Pri**” is indicated in the upper part of the display.

Priority channel sampling occurs only with Standard conventional scanning. It does not occur with Radio Wide scanning, when listening to any type of SMARTNET/SmartZone call, or when transmitting. A series of “ticks” may be heard and the indicator on the top panel flashes green when the priority channel is sampled while listening to a message on some other channel.

The priority sampling times are programmed by the following parameters:

**Lookback Time A** - This time determines how often the priority channel is checked for activity. Times of

0.25-4.00 seconds in 0.25-second steps can be programmed.

**Lookback Time B** - This time determines how often the priority channel is checked once an incorrect Call Guard (CTCSS/DCS) or NAC code is detected. Since it takes much longer to detect an incorrect Call Guard signal than a carrier, this time should be relatively long to prevent the interruptions from making a message difficult to understand. Times of 0.5-8.0 seconds can be programmed in 0.5-second steps.

### Changing The Priority Channel

If a specific priority channel is associated with the current scan list, it can be changed if the Priority option switch is programmed. Proceed as follows:

1. Select the scan list number to be edited as described in Section 2.6.12. If a list is not selected, the last active scan list is automatically edited.
1. Make sure that both radio-wide and standard scanning are off (“**Scan**” is not indicated in display).
2. Select the channel that you want to be the priority channel using the channel selector switch on the top panel. If the channel is in a different zone, also select the appropriate zone.
3. Press the Priority option switch and the “**Pri**” is displayed to indicate that the selected channel is now the priority channel.

## 2.6.14 PLACING AND RECEIVING STANDARD CONVENTIONAL CALLS

Standard conventional calls are calls to or from other mobile units on the selected channel. The proper coded Call Guard signaling (see Section 2.6.6) may need to be transmitted for them to receive your call and also for you to receive their calls. Proceed as follows to place and receive these calls:

### Placing a Standard Conventional Call

1. Turn power on and set the volume as described in Section 2.4.2. Select the channel programmed for the mobile you want to call (see Section 2.4.8).

2. Monitor the channel automatically or manually as described in Section 2.6.3.
3. Press the PTT switch and the call proceeds as follows:
  - If the Busy Channel Lockout feature is programmed on the channel, the transmitter is automatically disabled if the channel is busy (see Section 2.6.5).
  - Otherwise, busy and out-of-range conditions are not indicated and speaking can begin after monitoring the channel as described in Section 2.6.3.
4. Press (and hold) the PTT switch to talk and release it to listen.

#### Receiving a Standard Conventional Call

1. Select or scan the channel programmed for the call you want to receive (refer to Sections 2.5 and 2.6.12 for more scanning information).
2. When the call is received, press the PTT switch to talk and release it to listen. If scanning, you may have to respond before scanning resumes to ensure that the response occurs on the channel of the call.

#### 2.6.15 DTMF/ANI SIGNALING

DTMF (Dual Tone Multi-Frequency) tones can be generated manually or automatically for ANI (Automatic Number Identification) and other purposes. The following options may be enabled by system operator programming for each conventional channel:

**DTMF Keypad** - Pressing 0-9, \*, or # on the keypad while holding the PTT switch transmits the corresponding tone until the key is released.

**Pre-Tx ANI** - A preprogrammed ANI sequence is automatically sent when you press the PTT switch.

**Post-TX ANI** - A preprogrammed ANI sequence is automatically sent each time you release the PTT switch.

**Disabled** - All DTMF signaling is disabled.

#### 2.6.16 PROJECT 25 MODE FEATURES

##### Individual, Group, and NAC Codes

**Individual ID** - Each transceiver that operates on Project 25 (digital) channels is programmed with an 8-digit individual ID. This ID is unique for each transceiver and can be any number from 1-16777216. When power is turned on with a Project 25 channel selected, this ID is briefly displayed.

**Group ID** - Each Project 25 channel is programmed with a group ID that determines which group of mobiles will receive the call. A call is received if any Project 25 channel is programmed with that group and the correct NAC is detected (see following description). Group IDs can be any number from 0-4095.

**NAC** - Project 25 conventional channels use a NAC (Network Access Code) instead of Call Guard squelch coding (see Section 2.6.6) to control which calls are received on a channel. The NAC can be 0-4095, and each transmit and receive channel can be programmed for a different code. Other operation, such as monitoring before transmitting, is similar to that of standard analog channels.

To receive a Project 25 group call, the talk group programmed with the group ID being transmitted must be selected or scanned. In addition, the receive NAC programmed for that channel must be detected.

##### Viewing Individual ID

Each transceiver which operates on Project 25 (digital) channels is assigned an eight-digit individual ID. When power is turned on with a Project 25 channel selected, the individual ID of your radio is briefly displayed.

##### Changing Talk Group Assigned To A Channel

If the Talk Group Select option switch is programmed and user talk group programming is permitted on the channel, the talk group assigned to a channel can be changed. This change is permanent

(cycling power does not reselect the old talk group). Proceed as follows:

1. Select the channel to be changed and then press the Talk Group Select option switch.
2. Display the talk group to be assigned to that channel by pressing the ▼ and ▲ keys. Talk groups are indicated by an alias (unique alphanumeric identification).
3. To select that talk group and return to normal operation, press the Talk Group select switch again. If talk group selection has been disabled on the channel by programming, the talk group does not change and an error tone sounds.

### Individual Calls

If the Individual Call option switch is programmed and the radio is a full keypad (18-key) mode, individual calls can be placed to a specific mobile radio on Project 25 channels. This call differs from standard group calls in that only one mobile instead of entire groups of mobiles may receive the call. To respond to an individual call, simply press the PTT switch and begin talking before a call timer expires. Proceed as follows to place this call:

1. Press the Individual Call option switch and the identification of the last individual call placed is displayed as IDxxxxxx.
2. If required, enter the ID of the mobile being called using the keypad.
3. Press the PTT switch and begin talking.

When individual calls are received, the transceiver may be programmed to display the selected talk group, the talk group of the call, or the ID of the calling radio.

## 2.6.17 CONVENTIONAL SECURE COMMUNICATION

### Introduction

There are two different protocols that can be used to provide secure communication on conventional

analog channels: SecureNet™ and 460 scrambling. More information on these protocols follows.

### SecureNet

SecureNet is a proprietary Motorola protocol that digitizes the voice and then encrypts it using the DES algorithm. It provides the highest level of security. There are two DES protocols:

- DES (CFB) uses cipher feedback DES encryption. A disadvantage of this type is reduced communication range when compared to clear voice.
- DES-XL uses counter addressing feedback DES. It provides better range but at lower voice quality.

The transmission mode (DES or DES-XL) is selected by the programming software for each SecureNet analog channel. If a channel is programmed for DES-XL, it will also receive DES, but transmissions always occur in DES-XL.

Each SecureNet capable channel is assigned an encryption number from 0-15. The key corresponding to this number is loaded into the radio using the Motorola key loader. There is a maximum of 16 keys that can be loaded into the radio at one time.

Transmissions on an analog channel are in the clear mode if the channel has been strapped to the clear mode by programming, and in the SecureNet mode if it has been strapped to SecureNet. If the channel has been strapped to “switched”, the mode is selected by the Clear/Secure option switch. When a message is received or transmitted in the secure mode, “**Sec**” is indicated in the upper part of the display.

If an attempt is made to transmit a secure message without loading the corresponding key, “KEYFAIL” is displayed. The message must then be transmitted in the clear mode (this is possible only if the channel is strapped to “switchable”) or the key must be loaded.

### 460 Scrambling

The 460 Scrambling protocol is a proprietary Transcrypt protocol that is compatible with the stand-alone scrambling option from Transcrypt. If equipped

with the 460 Scrambler, a Clear/Secure option switch may be programmed. Pressing this switch changes the transmission mode for the selected channel and momentarily displays either “CLEAR” or “SECURE”.

In the coded mode, transmissions are in scrambled voice on any 460-enabled channel and the mobile receiving the call automatically responds in the scrambled mode because the receiver automatically switches between the clear and coded modes.

Although 16 generic codes are loaded, only one is active and all 460-enabled channels use this code. The 460 scrambling option also provides several other signaling enhancements including Digital ID, Automatic Status and Location Update, Individual and Group ID calling, and Emergency.

### Transmit Mode Options

Either the SecureNet or 460 protocol can be selected, and then the following transmit options are available for each:

**Clear** - All calls are in the clear mode unless responding to a secure call. If the response is then made within the delay time (see Section 2.5.4), it occurs in the secure mode.

**Coded** - All calls are made in the selected secure mode.

**Switched** - The mode is selected by the Clear/Secure switch. With 460 scrambling, if responding to a secure call, the secure mode is automatically selected if the response occurs within the delay time. When the clear mode is selected by this switch, “CLEAR” is flashed, and when the secure mode is selected, “SECURE” is flashed.

### Receive Mode Options

With 460 scrambling, clear and scrambled signals are always autodetected. In addition, the user can switch between the clear and secure mode at any time using the Clear/Secure option switch. SecureNet signals are unintelligible when 460 scrambling is used and vice versa.

With the SecureNet protocol, the following receive options can be programmed:

**No Autodetect** - Only signals coded like the transmit signals are received.

**Secure Autodetect** - Both clear and SecureNet signals are automatically detected. This mode is automatically selected if the transmit mode is switch selectable.

**Proper Key Autodetect** - An incoming SecureNet call is compared against all of the available keys programmed into the radio. If a match is found, the call is decrypted using matched key.

### Project 25 (Digital) Channels

Project 25 digital channels use the DES-OFB protocol. Using this protocol on digital channels does not result in the degraded range that occurs with analog channels. The same transmit mode options are available as with the preceding analog operation. In the receive mode, clear and secure messages are always automatically detected.

## 2.7 SMARTNET/SMARTZONE FEATURES

### 2.7.1 INTRODUCTION

The following information describes features unique to the SMARTNET and SmartZone operating mode (see brief description in Section ). Refer to Section 2.4 for information on features common to all operating modes, and to Section 2.4.12 for information on conventional mode features.

### 2.7.2 VIEWING UNIT ID

Each radio in a SMARTNET system is identified with a six-digit system ID and Unit ID. To display these IDs, make sure that a SMARTNET channel is selected and then turn power off and then on again. The system ID is briefly displayed as SYxxxxxx followed by the Unit ID as EDxxxxxx.

### 2.7.3 STANDARD GROUP CALLS

Standard group calls are between you and another mobile, group of mobiles, or a control station (a radio

at a fixed location). Most calls you make will probably be this type.

### Placing a Standard Group Call

1. Turn power on and set the volume as described in Section 2.4.2. Select the channel programmed for the talk group you want to call (see Section 2.4.8). A regular or announcement talk group can be selected.
2. If encryption is used, it may be automatically selected. If not, select the secure mode if desired by pressing the Clear/Secure option switch. Refer to Section 2.4.13 for more information.
3. Press the PTT switch and when the alert tone sounds, begin talking. Other indications that may occur are as follows:
  - If in the secure mode and your transceiver does not have the proper encryption key, “KEYFAIL” is displayed and the call must be made in the clear mode (selected by the Clear/Secure option switch if enabled on the channel).
  - If the busy tone sounds and “BUSY” is displayed, the system is busy. Release the PTT switch and wait for the call back tone to sound. Then press the PTT switch within 3 seconds and begin talking.
  - If a continuous tone sounds while pressing the PTT switch and “NO SYS” is displayed, you may be out-of-range. Drive closer or away from shielding objects and try again.
  - If your unit ID is invalid, the call is being made to an invalid group ID, or group calls are not allowed, “REJECT” is displayed and an alert tone sounds.
  - If an attempt is made to select the secure mode and there is no available secure channel, “NO SEC” is flashed and the call continues in the clear mode.
  - If an attempt is made to change from the secure to the clear mode and this is not permitted, “SEC ONLY” is displayed and the call continues in the secure mode.

### Receiving a Standard Call

When a SMARTNET/SmartZone group call is received, the transceiver can be programmed to display the Individual ID of the calling mobile and/or the received talk group alias. The Individual ID is briefly displayed when the call is received and the talk group and channel alias are then alternately displayed (if applicable).

## 2.7.4 ENHANCED PRIVATE CONVERSATION CALLS

### General

Private calls allow you to place a call to a specific mobile unit. Either the Enhanced Private Conversation™ or Private Conversation II™ modes may be programmed depending on the capabilities of the radio system. The Enhanced Private Conversation mode is described in the following information, and the Private Conversation II mode is described in Section 2.7.5.

The Private Call option switch is required to place these calls, and either that switch or the Call Response option switch is required to receive them. Proceed as follows.

### Placing an Enhanced Private Conversation Call

This call can be initiated by selecting the unit ID from a call list (list entry) or by directly entering it using the keypad (direct entry). Direct entry is available with full keypad (18-key) models only. Proceed as follows:

### List Entry Method

1. With a SMARTNET/SmartZone channel selected, momentarily press the Private Call option switch. The tag (alias) of the last ID called is displayed if it matches an ID in your call list. Otherwise, the last ID called is displayed.
2. Enter the two-digit index of the desired ID if you know it or scroll through the list using the ▲ and ▼ keys until you find the desired ID. Press the CLR key to cancel the call.

3. Press the PTT switch to initiate the call. The display then indicates the alias of the destination radio. If the entered digits do not correspond to a valid list entry, "INVALID" is displayed and an error tone sounds. Proceed to the bulleted list following the next method for other conditions that may occur next.

#### Direct Entry Method (Full Keypad Models Only)

1. With a SMARTNET/SmartZone channel selected, press and hold the Private Call option switch until a tone sounds (approximately 1 second). The last ID called is displayed.
2. Using the 0-9 keys, enter the ID (all six digits) of the mobile unit you are calling. To erase the last digit, press the ▼ key, and to cancel the call, press the **CLR** key.
3. Press the PTT switch to initiate the call. If the entered ID did not contain six digits, "INVALID" is momentarily displayed, an error tone sounds, and the call is not initiated. If the entered ID is valid, the display indicates the alias of the ID if it matches an ID in your call list. Otherwise, the ID you entered continues to be displayed. Any of the following conditions may then occur:
  - If the radio you are calling is on the air, "WAIT" is displayed and telephone type "ringing" is heard for 20 seconds or until the called party answers.
  - If the called party answers and the call is successful, the person's voice is heard and the call is carried on the same as a group call. To end the call at any time, press the **CLR** key.
  - If the called party does not answer within 20 seconds, "NO ANS" is displayed and a continuous tone sounds. End the call by pressing the **CLR** key.
  - If the called radio is not in service, no ringing is heard, "NO ACK" is displayed, and a continuous tone sounds. End the call by pressing the **CLR** key.
  - If neither your radio nor the radio being called is authorized to make unit-to-unit calls, "REJECT" is displayed and a continuous tone sounds. End the call by pressing the **CLR** key.

- If the called party answers but the radio system is busy, four low tones sound and "BUSY" is displayed. When the system is no longer busy, the call back tone sounds.
- If in the secure mode and your transceiver does not have the proper encryption key, "KEYFAIL" is displayed and the call must be made in the clear mode (selected by the Clear/Secure option switch if enabled on the channel).
- If an out-of-range condition exists or the radio system is not in service, "LOST CALL" is displayed and a continuous tone sounds. End the call by pressing the **CLR** key.

#### Receiving an Enhanced Private Conversation Call

These calls are automatically received if a SMARTNET/SmartZone channel is selected. Proceed as follows:

1. When a call is received, a recurring unit call tone (three beeps) sounds for up to 20 seconds and "CALL" is displayed.
2. To answer the call, press the Private Call option switch and then the PTT switch and begin talking. The alias of the incoming call is displayed if the ID is in your call list. Otherwise, the unit ID is displayed. *NOTE: If the Private Call option switch is not pressed before the PTT switch, a group call is transmitted on the selected group.*
  - To end the call when the conversation is complete or at any other time, press the **CLR** key.
  - If unit-to-unit (private) calls are not permitted (Private Call switch not programmed), press the Call Response option switch, if available, to answer the call.
  - If the call is not answered within 20 seconds, it is automatically terminated.
  - If the radio system is busy, four low tones sound and "BUSY" is displayed. When the system is no longer busy, the call back tone (four beeps) is heard and your radio automatically starts transmitting. Press the PTT switch to continue the call.

## 2.7.5 PRIVATE CONVERSATION II CALLS

### General

Private calls allow you to place a call to a specific mobile unit. Either the Enhanced Private Conversation™ or Private Conversation II™ modes may be programmed depending on the capabilities of the radio system. Operation in the Enhanced Private Conversation mode was described in Section 2.7.4, and operation in the Private Conversation II mode is described in the following information.

The Private Call option switch is required to place these calls, and either that switch or the Call Response option switch is required to receive them. Proceed as follows.

### Placing a Private Conversation II Call

This call can be initiated by selecting the unit ID from a call list (list entry) or by directly entering it using the keypad (direct entry). Direct entry is available with full keypad (18-key) models only. Proceed as follows:

#### List Entry Method

1. With a SMARTNET/SmartZone channel selected, momentarily press the Private Call option switch. The tag (alias) of the last ID called is displayed if it matches an ID in your call list. Otherwise, the last ID called is displayed.
2. Enter the two-digit index of the desired ID if you know it or scroll through the list using the ▲ and ▼ keys until you find the desired ID. Press the **CLR** key to cancel the call.
3. Press the PTT switch to initiate the call. The display then indicates the alias of the destination radio. Wait approximately 1 second and then begin talking. Proceed to the bulleted list which follows the next method for conditions that may then occur.

#### Direct Entry Method (Full Keypad Models Only)

1. With a SMARTNET/SmartZone channel selected, press and hold the Private Call option switch until a tone sounds (approximately 1 second). The last ID called is displayed.

2. Using the 0-9 keys, enter the ID (all six digits) of the mobile unit you are calling. To erase the last digit, press the ▼ key, and to cancel the call, press the **CLR** key.
3. Press the PTT switch to initiate the call. If the entered ID did not contain six digits, “INVALID” is momentarily displayed, an error tone sounds, and the call is not initiated. If the entered ID is valid, the display indicates the alias of the ID if it matches an ID in your call list. Otherwise, the ID you entered continues to be displayed. Any of the following conditions may then occur.
  - If in the secure mode and your transceiver does not have the proper encryption key, “KEYFAIL” is displayed and the call must be made in the clear mode (selected by the Clear/Secure option switch if enabled on the channel).
  - If the called party answers and the call is successful, the person’s voice is heard and the call is carried on the same as a group call. To end the call at any time, press the **CLR** key.
  - If the radio system is busy, four low tones sound and the “BUSY” is displayed. When the system is no longer busy, the call back tone (four beeps) is heard and a channel is automatically acquired. Press the PTT switch to continue the call.

### Receiving a Private Conversation II Call

Unit-to-unit calls are automatically received if a SMARTNET/SmartZone channel is selected. Proceed as follows:

1. When a call is received, an alert tone sounds and the caller’s voice is heard. While voice is heard, “CALL” is displayed.
2. To answer the call, press the Private Call option switch and then the PTT switch and begin talking. The alias of the incoming call is displayed if the ID is in your call list. Otherwise, the unit ID is displayed. *NOTE: If the Private Call option switch is not pressed before the PTT switch, a group call is transmitted on the selected group.*



- To end the call when the conversation is complete or at any other time, press the **CLR** key. If the call is not answered within 20 seconds, it is automatically terminated.
- If private calls are not permitted (Private Call switch not programmed), press the Call Response option switch, if available, to answer the call.

## 2.7.6 TELEPHONE CALLS

### General

Telephone calls allow you to place and receive calls over the public telephone system using your transceiver. If your transceiver is programmed for telephone calls (Phone option switch programmed), they are placed and received as follows:

### Placing a Telephone Call

Telephone calls can be placed by selecting the number from a preprogrammed phone number list (list entry) or by directly entering it using the keypad (direct entry). Direct entry is available with full keypad (18-key) models only. Proceed as follows:

### List Entry Method

1. With a SMARTNET/SmartZone channel selected, momentarily press the Phone option switch. The display indicates the alias of the last called telephone number if it is in your phone number list. Otherwise, the last eight digits of the last called telephone number are displayed.
2. Enter the index of the desired telephone number if you know it or scroll through the list using the ▲ and ▼ keys until you find the desired number. Press the **CLR** key to cancel the call.
3. Press the PTT switch to initiate the call. The display indicates “WAIT” while the connection to the phone system is occurring. Once connected, the normal dial tone is heard and the alias of the number being called is displayed. The radio then automatically dials the telephone number and the normal ringing or busy tone is heard. Proceed to the bulleted list which follows the next method for conditions that may then occur.

### Direct Entry Method (Full Keypad Models Only)

1. With a SMARTNET/SmartZone channel selected, press and hold the Phone option switch until a tone sounds (approximately 1 second). The display indicates the alias of the last called telephone number if it is in your phone number list. Otherwise, the last eight digits of the last called telephone number are displayed.
2. Enter the number using the **0-9**, **\***, and **#** keys. To enter a pause (indicated by “P”), press **\*** and then **#**. To erase the last digit, press the ▼ key. The number scrolls to the left in the display so that the eight right-most digits are always displayed. Numbers up to 16 digits (including pauses) can be entered. Press the **CLR** key to cancel the call.
3. Press the PTT switch or the **ENT** key to initiate the call. The display indicates “WAIT” while the connection to the phone system is occurring. Once connected, the normal dial tone is heard and the alias of the number being called is displayed. The radio then automatically dials the telephone number and the normal ringing or busy tone is heard. Any of the following conditions may then occur.
  - After the called party answers, press the PTT switch to talk and release it to listen. You cannot talk and listen at the same time because the radio cannot transmit and receive at the same time. Each time the PTT switch is released, a tone is heard by the other party that indicates when a response can be made. To end the call when the conversation is complete or at any other time, press the **CLR** key.
  - If the selected number is not valid, “INVALID” is momentarily displayed, an error tone sounds, and the call is not initiated. Select a valid number.
  - If enabled by system operator programming, a number can be dialed during a call by simply holding down the PTT switch and dialing the number.
  - If an out-of-range condition exists or the radio system is not in service, “NO PHONE” is displayed and a continuous tone sounds. End the call by pressing the **CLR** key.

- If you are not authorized to make telephone calls, “REJECT” is displayed and a continuous tone sounds. End the call by pressing the **CLR** key.
- If the radio system is busy, “BUSY” is displayed and a busy tone sounds. The call automatically proceeds when the radio system becomes available. If the call is ended before it proceeds, your position in queue is lost.
- If in the secure mode and your transceiver does not have the proper encryption key, “KEYFAIL” is displayed and the call must be made in the clear mode (selected by the Clear/Secure option switch if enabled on the channel).

### Answering a Telephone Call

Telephone calls are automatically received if a SMARTNET/SmartZone channel is selected. Proceed as follows:

1. When a telephone call is received, “ringing” similar to a standard telephone is heard and the display indicates “PHONE”.
2. To answer the call, press the Phone option switch and then press the PTT switch to talk and release it to listen.
3. To end the call when the conversation is complete or at any other time, press the **CLR** key. Also press the **CLR** key to ignore an incoming call and end it without answering.

### 2.7.7 CALL ALERT

The Call Alert™ feature allows pages to be sent and received. Proceed as follows:

#### Sending a Page

Pages can be placed by selecting the unit ID from a preprogrammed list (list entry) or by directly entering it using the keypad (direct entry). Direct entry is available with full keypad (18-key) models only.

#### List Entry Method

1. With a SMARTNET/SmartZone channel selected, momentarily press the Call Alert option switch. The tag (alias) of the last ID called is displayed if it matches an ID in your call list. Otherwise, the last ID called is displayed.
2. Enter the index of the desired ID if you know it or scroll through the list using the ▲ and ▼ keys until you find the desired ID. Press the **CLR** key to cancel the call.
3. Press the PTT switch to send the page. The display then indicates the alias of the radio being paged. Proceed to the bulleted list which follows the next method for conditions that may then occur.

#### Direct Entry Method (Full Keypad Models Only)

1. With a SMARTNET/SmartZone channel selected, press and hold the Call Alert option switch until a tone sounds (approximately 1 second). The last ID called or paged is displayed.
2. Using the **0-9** keys, enter the 6-digit ID of the unit you are calling. To erase the last digit, press the ▼ key or press the **CLR** key to cancel the page.
3. Press the PTT switch to send the page. If the entered ID is invalid, “INVALID” is momentarily displayed and the page is not sent. If the entered ID is valid, the display indicates the alias of the ID if it matches an ID in your call list. Otherwise, the ID you entered continues to be displayed. The page is then sent and any of the following conditions may then occur.
  - If the radio you are paging is on the air and received your page, a signaling success tone (six beeps) sounds. The alias of the selected channel is then displayed continuously.

- If the radio you are paging is not in service, a tone sounds and “NO ACK” is displayed after trying for 6 seconds. Press the **CLR** key to cancel the page or try again.

### Answering a Page

1. When a page is received, the display indicates "PAGE" and a recurring received page tone sounds (five beeps) sounds.
2. To clear and ignore the page, press the **CLR** key.  
*NOTE: If the CLR key is programmed for the Private Call function, it will not clear the page.*
3. Answering a page is the same as placing a private call. Therefore, press the Private Call option switch and follow the instructions for placing a private call in Sections 2.7.4 or 2.7.5, whichever is applicable.

### 2.7.8 MESSAGING

The messaging feature allows preprogrammed messages to be sent to your dispatcher. Up to 16 messages can be preprogrammed, and they are identified by a tag (alias). If a Message option switch is programmed, messages are sent as follows:

1. Momentarily press the Message option switch. The alias of the last message sent is displayed.
2. Enter the index of the desired message if you know it or scroll through the list using the ▲ and ▼ keys until you find the desired message. Press the **CLR** key to cancel the message.
3. Press the PTT switch to send the message. When the message is received and acknowledged by the dispatcher, a signaling success tone (six beeps) sounds and the display returns to the normal channel indication. If there is no acknowledgment after 6 seconds, a tone sounds and "NO ACK" is displayed. Press the **CLR** key to return to normal operation.

### 2.7.9 SENDING STATUS CONDITIONS

The status feature allows you to send your current status to your dispatcher. Up to eight status conditions can be preprogrammed, and they are identified by an alias (name). If the Status option switch is programmed, status conditions are sent as follows:

1. Momentarily press the Status option switch. The alias of the last status sent is displayed.

2. To change the displayed status, enter the index of the desired status if you know it or scroll through the list using the ▲ and ▼ keys until you find the desired status. Press the **CLR** key to cancel this function.
3. Press the PTT switch to send the status. When the message is received and acknowledged by the dispatcher, a signaling success tone (six beeps) sounds and the display returns to the normal channel indication. If there is no acknowledgment after 6 seconds, a tone sounds and "NO ACK" is displayed. Press the **CLR** key to return to normal operation.

### 2.7.10 EMERGENCY ALARM AND EMERGENCY CALL

Emergency alarms and emergency calls are separate functions that can be individually programmed on SMARTNET/SmartZone channels. The Emergency switch is pressed to initiate these features. This switch is the orange button located next to the antenna connector.

An emergency alarm is a special data transmission to alert your dispatcher of an emergency situation, and an emergency call is an urgent request for access to a voice channel. The emergency alarm and call are transmitted on the emergency talk group or announcement group that has been preprogrammed by your system operator on the currently selected channel. Proceed as follows:

1. To transmit an emergency alarm, select a SMARTNET/SmartZone channel that has that feature enabled and then press the Emergency option switch.
2. The emergency alarm is then transmitted and "EMERGENCY" is indicated in the display for a short time. Transmitting continues until an acknowledgment is received (indicated by two beeps) or the programmed number of attempts have occurred. Silent operation may also be programmed in which case no audio or visual indication of the alarm condition occurs.
3. To transmit an emergency call, press the Emergency option switch with a SMARTNET/SmartZone channel selected that has that feature enabled. Then manually press the PTT switch and begin speaking as

with a standard call. All calls that follow are then emergency calls and they occur on the emergency talk group.

4. To exit the emergency mode, power must be turned off and then on again.

### 2.7.11 FAILSOFT OPERATION

If a failure occurs in the SMARTNET/Smart-Zone system so that it cannot be used, the transceiver automatically enters the failsoft mode. When this mode is selected, the display alternately indicates “FAILSOFT” and the alias of the selected channel.

When in the failsoft mode, operation is in the conventional mode on a preprogrammed failsoft channel. If a transmission is attempted before a failsoft channel is located, a continuous tone sounds until the PTT switch is released. When the radio system returns to normal operation, this condition is automatically detected and normal operation resumes.

### 2.7.12 SMARTNET/SMARTZONE SCANNING

Scanning on a SMARTNET/Smartzone channel is similar to the standard and radio wide scanning described in Section 2.5. Each channel can be programmed with a different scan list that includes up to 16 channels, one of which can be a priority channel. These scan lists are user programmable if the Scan Edit option switch is programmed, and nuisance channels can be temporarily deleted (see Section 2.5.8).

Scanning is enabled/disabled by the Scan option switch. In addition, channels can be programmed so that scanning automatically starts whenever the channel is selected. Scanning is temporarily disabled and “**Scan**” turns off if a channel is selected that has scanning disabled. Then when a channel is selected again that permits scanning, it is automatically re-enabled.

In addition to calls on channels in the scan list, pages, private calls, and telephone calls are received while scanning. Messages on the priority channel are received while listening to lower priority messages. However, private and telephone calls are not interrupted by calls on the priority channel.

When responding to messages in the scan mode, programming determines if the response always occurs on the talk group of the call or the selected talk group (if they are different). Transmissions occurring at other times always occur on the selected talk group.

### 2.7.13 DYNAMIC REGROUPING

The dynamic regrouping feature allows a dispatcher to switch users to a dynamically defined channel to receive an important message. Dynamic regrouping operates as follows:

1. When this command is received, the alternating dynamic regrouping tone sounds, the transceiver automatically changes to the regrouping channel, and the display alternately indicates “REGROUP” and the alias of the selected channel. All transmitting and receiving then occurs on this channel.
2. To reset all talk and announcement groups to normal so that only the designated regrouping channel is on the dynamic group, manually select the designated regrouping channel if you know it. If this channel is not selected or there is no designated regrouping channel, all transmissions occur on the dynamically assigned group regardless of which channel is selected, and the regrouping tone sounds each time the PTT switch is pressed.
3. When regrouping is canceled by the dispatcher, transceiver operation returns to normal.

### 2.7.14 SMARTZONE FEATURES

#### Introduction

As described in Section , the SmartZone<sup>®</sup> mode provides wide area coverage by allowing roaming between SMARTNET and conventional sites. Smart-Zone operation is the same as SMARTNET with the following additional features.

#### Determining Current Site

To determine the current radio site, momentarily press the Site Search option switch (if programmed). If currently registered on a site, “SITE x” is displayed, where “x” is the site number. The display then indicates the RSSI (Receive Signal Strength Indicator)

value of the current site as “RSSI x” and then returns to displaying the channel alias.

#### Searching For a New Site

To search for a new site, press the Site Search option switch (if programmed) to toggle through the available sites. “RSSI x” is displayed as just described and the channel alias is then displayed.

#### Locking/Unlocking a Site

It is sometimes desirable to stay on the current site regardless of signal level. To lock the radio on the current site so that it does not search for another, press the Site Lock option switch (if programmed). The display then momentarily indicates “LOCK x” to indicate that the current site is locked (“x” is the current site number). To unlock the site, press the Lock switch again and “UNLOCK” is momentarily displayed.

When locked on a site, it is still possible to search for a different site using the site search function described in the preceding section. When a new site is found, the radio is then locked on that site.

### 2.7.15 SMARTNET/SMARTZONE SECURE COMMUNICATION

On analog SMARTNET/SmartZone channels, either the SecureNet or 460 protocols can be selected. Operation is similar to conventional channel secure communication described in Section 2.6.17.

On digital SMARTNET/SmartZone channels, only the DES-OFB protocol is available. Talk groups can be strapped to Clear, Coded, or Switch selectable, and clear and secure messages are always autodetected.

The following calls require their own encryption key selection: emergency, failsoft, patch, telephone, private, and system-wide.

## 2.8 SUPERVISORY TONES

#### Single Beep (Alert Tone)

- Power was turned on and a successful power-up sequence occurred (see Section 2.4.2).

- The time-out timer is about to expire or the penalty timer has expired (Sections 2.4.10 and 2.6.7).
- The conversation timer is about to expire (Section 2.6.8).
- The system received your page but the paged mobile is not on the air (Section 2.7.7).
- Telephone interconnect is not operational (Section 2.7.6).

#### Continuous Tone (Invalid or No Acknowledge Condition)

- A transmission is being attempted on an unprogrammed channel or a conventional channel programmed as receive-only.
- The transmitter is disabled by the busy channel lockout feature (Section 2.6.5).
- The transmitter has been disabled by the time-out timer feature (Section 2.4.10).
- The transmitter has been disabled by the conversation timer (Section 2.6.8).
- An out-of-range condition exists (SMARTNET/SmartZone only).
- A transmission is being attempted before the penalty timer has expired (Section 2.6.7).
- Dynamic regrouping has been exited but the dynamic regrouping channel is still selected (Section 2.7.13).
- The paged mobile did not acknowledge the page (Section 2.7.7).
- The message that was sent has not been acknowledged (Section 2.7.8).
- The status condition that was sent has not been acknowledged (Section 2.7.9).

#### Single Short Medium-Pitch Tone

- A valid key has been pressed.

#### Single Short Low-Pitch Tone

- An invalid key has been pressed.

#### Six Beeps (Recurring)

- The page was received (Section 2.7.7).

#### Three Beeps (Recurring)

- A unit-to-unit call was received (Section 2.7.4).

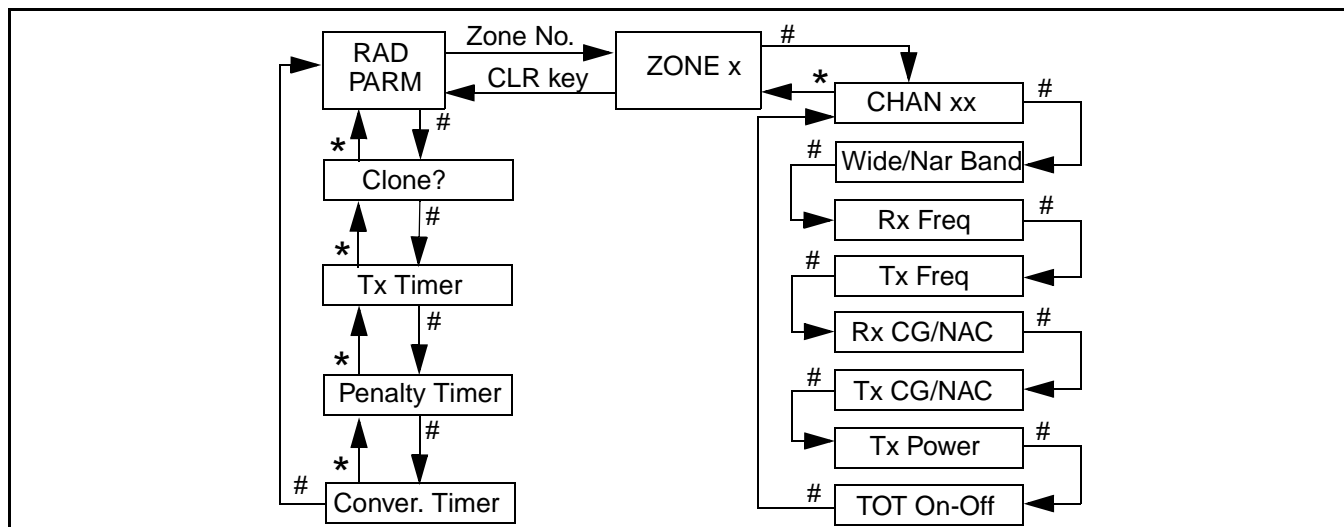

Figure 2-3 Keypad Programming Flowchart

### Six Beeps

- The paged radio received the page and acknowledged it (Section 2.7.7).
- The message that was sent has been received and acknowledged (Section 2.7.8).
- The status condition that was sent has been received and acknowledged (Section 2.7.9).

### Two Beeps

- The emergency alarm condition was acknowledged (Section 2.7.10).

### Gurgle-Like Tone

- Dynamic regrouping has occurred (Section 2.7.13).
- Dynamic regrouping has occurred but the regrouping channel is not selected (Section 2.7.13).

### Four Low Tones (Busy Signal)

- The radio system is busy or a busy condition exists when making a telephone call.

### Four Alternating High and Low Tones

- A channel is available after a busy condition occurred (SMARTNET/SmartZone only).

## 2.9 KEYPAD PROGRAMMING

### 2.9.1 INTRODUCTION

Keypad programming is available with full keypad (18-key) models if the Keypad Programming option switch is programmed. It is then selected by pressing this switch and entering the programming password. This password is a series of eight digits selected preprogrammed using PCTrunk, and it prevents unauthorized changing of radio programming. The default password is eight zeros, and the **ENT (F4)** key must be pressed after the digits are entered. This password is not user reprogrammable.

Keypad programming allows conventional channel parameters such as the transmit and receive frequency and Call Guard squelch code to be changed. In addition, several conventional mode timers can be programmed. It cannot be used to reprogram disabled or SMARTNET/SmartZone channels.

### 2.9.2 MENU STRUCTURE

When the Keypad Programming mode is selected by pressing the option switch and entering the password, “**Pgm**” is displayed along with the first menu parameter “**RAD PARM**”. The flowchart in Figure 2-3

shows the keypad programming mode menu structure for this radio.

The information which follows describes how the various parameters are programmed. When programming is complete, exit the keypad programming mode by turning power off. Do not turn power on again for a short time so that the radio has time to copy the settings to memory.

### 2.9.3 CLONING

The cloning mode is used to program one transceiver with another with identical information. A special cloning cable is required to connect the transceivers together. To enter this mode, on the master (sending) radio, press the # (pound) key with “RAD PARM” displayed. The clone mode is then indicated by “CLONE?”. To return to “RAD PARM” without cloning, press the \* key. To clone a radio, connect the cloning cable, power up the slave (receiving) radio, and press the **ENT** key on the master (sending) radio. When cloning is successfully completed, “RAD PARM” is again displayed. Encryption keys are not transferred.

### 2.9.4 TIMER PROGRAMMING

The menus to program the following timers are accessed by repeatedly pressing the # key with “RAD PARM” displayed. To return to the previous adjustment, press the \* key.

**TX TMR** - Programs the transmit time-out timer (see page 7). Press the ▼ and ▲ keys to decrement/increment the timer in 15-second steps (“0” disables it). When the desired value is displayed, store it by pressing the **ENT (F4)** key.

**PEN TMR** - Programs the penalty timer (see page 12). Press the ▼ and ▲ keys to decrement/increment the timer in 15-second steps (“0” disables it). When the desired value is displayed, store it by pressing the **ENT (F4)** key.

**CONV TMR** - Programs the conversation timer (see page 12). Press the ▼ and ▲ keys to decrement/increment the timer in 30-second steps (“0” disables it). When the desired value is displayed, store it by pressing the **ENT (F4)** key.

## 2.9.5 CHANNEL PROGRAMMING

### Zone Selection

The zone containing the channel to be programmed must be selected if applicable. To do this, with “RAD PARM” displayed press the key corresponding to the zone containing the channel. Alternatively, press the ▲ and ▼ keys to scroll through the programmed zones and the “RAD PARM” selection. The zone selection mode is indicated by “ZONE x”. To return to “RAD PARM”, press the **CLR** key. To proceed to channel parameter programming described in the next section, press the # key.

### Channel Selection

The channel to be programmed must be selected. To do this, press the # key with “ZONE x” displayed as described in the preceding section. The display then indicates “CHAN xx”. Then to select the desired channel, press the ▲ and ▼ keys to scroll through the programmed channels or enter the channel number directly using the number keys. Disabled or SMARTNET/SmartZone channels cannot be selected.

To exit back to the “ZONE x” display, press the \* key with “CHAN xx” displayed. To save the selection and proceed with the channel parameter programming described in the next section, press the **ENT** or # key.

### Channel Parameter Programming

After selecting the channel to be programmed as described in the preceding section, the following channel parameters can be programmed. To scroll through these parameters, press the **ENT** or # key with “CHAN xx” displayed. To go back to the previous field, press the \* key. The squelch control parameters are unique to the type of conventional channel selected (analog or Project 25).

**Channel Spacing** - Selects either “WIDE” or “NARROW” band channel spacing on analog channels only. Press the ▲ and ▼ keys to toggle between “WIDE” and “NARROW”, and when the desired setting is displayed, save it and proceed to the next parameter by pressing the **ENT** or # key.

**Receive Frequency** - When the **Rx** icon is indicated to the left of **Pgm** and a frequency or eight zeros is displayed, the receive channel frequency can be programmed. Press the **CLR** key to clear the current frequency and then type in the new frequency. When the desired frequency is displayed, save it and proceed to the next parameter by pressing the **ENT** or **#** key.

**Transmit Frequency** - When the **Tx** icon is indicated to the left of **Pgm** and a frequency or eight zeros is displayed, the transmit frequency is programmed the same as the Receive Frequency above.

### Squelch Control (Analog Channels)

**Receive CTCSS/DCS** - When “TN xxxx” or “DIG xxx” is displayed with the **Rx** icon indicated to the left of **Pgm**, the receive Call Guard (CTCSS/DCS) code can be programmed. Press the **CLR** key to clear the current code and toggle between the CTCSS (tone) and DCS (digital) modes. Press the **▲** and **▼** keys to scroll through the available codes. When the desired code is displayed, save it and proceed to the next parameter by pressing the **ENT** or **#** key.

**Transmit CTCSS/DCS** - When “TN xxxx” or “DIG xxx” is displayed with the **Tx** icon indicated to the left of **Pgm**, the transmit Call Guard (CTCSS/DCS) code can be programmed the same as the Receive CTCSS/DCS above.

### Squelch Control (Project 25 Channels)

**Receive NAC** - When “NAC xxx” is displayed with the **Rx** icon indicated to the left of **Pgm**, the receive Network Access Code (NAC) can be programmed. This can be any number from 0-4095. Press the **CLR** key to clear the current code and then enter the desired code using the number keys. When the desired code is displayed, save it and proceed to the next parameter by pressing the **ENT** or **#** key.

**Transmit NAC** - When “NAC xxx” is displayed with the **Tx** icon indicated to the left of **Pgm**, the receive NAC can be programmed the same as the Receive NAC described above.

**Transmit Power Level** - When any of the following indications are displayed, the power output level for the channel can be programmed. Press the **▲** and **▼** keys to scroll through the choices. When the desired setting is displayed, save it and proceed to the next parameter by pressing the **ENT** or **#** key.

- POWER HI - High transmit power
- POWER LO - Low transmit power
- POWER SW - Switchable power selectable by the High/Low power switch. This choice is not available if that switch is not programmed.

**Time-Out Timer** - When “TOT ON” or “TOT OFF” is displayed, the time-out timer can be enabled or disabled on the current channel. Press the **▲** and **▼** keys to toggle between the on and off mode. To return to the “CHAN xx” display, press the **ENT** or **#** key.

### Programming Additional Channels and Exiting Programming Mode

- To program another channel in the current zone, press the **ENT** or **#** key to redisplay “CHAN xx” and then repeat starting with “Channel Selection”.
- To program channels in another zone, press the **\*** key with “CHAN xx” displayed to display “ZONE x” and repeat this procedure starting with “Zone Selection”.
- If programming is complete, exit the keypad programming mode by turning power off. Do not turn power on again for a short time to allow the radio time to copy the settings into memory.



## SECTION 3 TRANSCEIVER PROGRAMMING

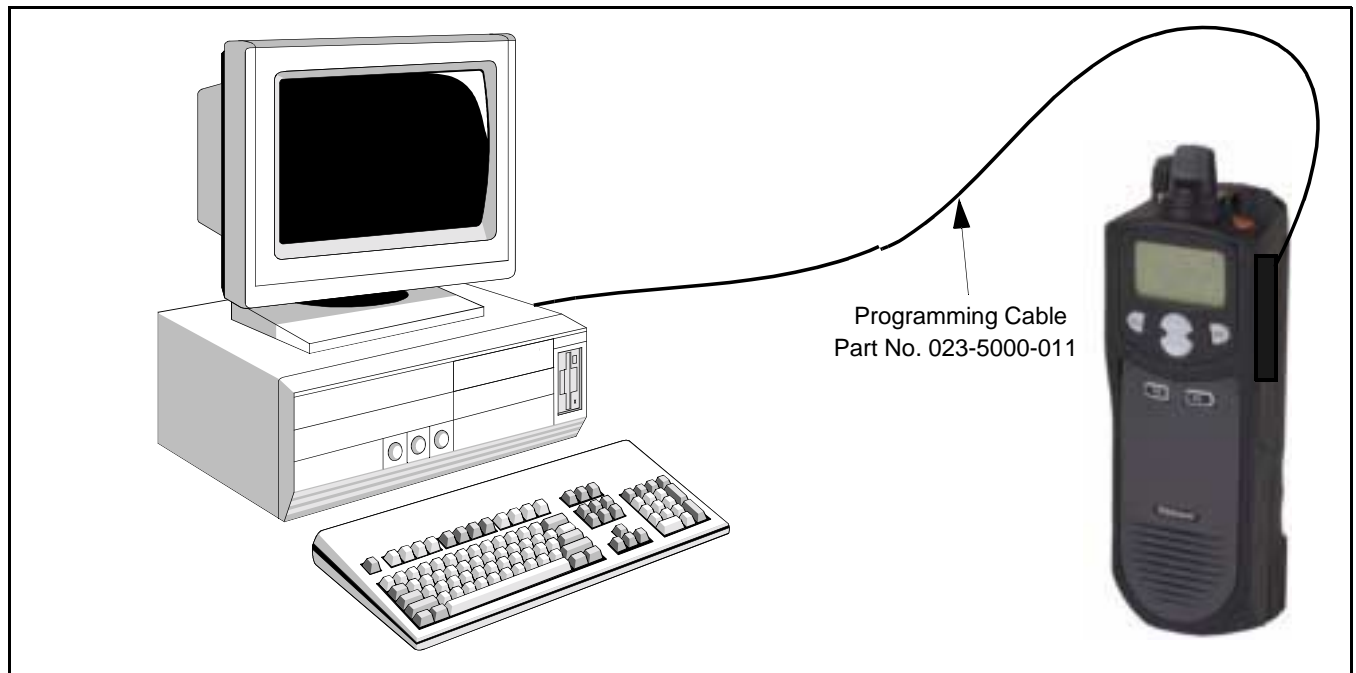

Figure 3-1 Programming Setup

## 3.1 GENERAL

## 3.1.1 PROGRAMMING SETUP

The following items are required to program the transceiver. The part numbers of this equipment are shown in Table 1-1 in Section 1. The programming set-up is shown above.

- IBM® PC or compatible personal computer
- Programming Cable, Part No. 023-5000-011
- PCTrunk programming software, Part No. 023-9998-453

*NOTE: The -011 cable, -453 software, and a PCTrunk manual are included in the 5005 Series Programming Kit, Part No. 250-5000-003.*

## 3.1.2 COMPUTER DESCRIPTION

The computer used to run this program should meet the following minimum requirements:

- Windows® 3.1 or 95/98 (Windows NT/2000 is supported only by PCTrunk Version 5.10.0 or later).

- Intel® 486 processor or equivalent
- At least 4 MB of RAM
- A hard disk drive with at least 5 MB of free space
- A CD-ROM drive
- An available serial port

*NOTE: With the descriptions which follow, it is assumed that you have a basic understanding of how to use your Windows-based operating system. If you are not familiar with some of the Windows functions described, refer to your Help Screens and manuals included with your Windows software.*

## 3.1.3 PCTRUNK SOFTWARE INSTALLATION

The PCTrunk software is supplied on a CD-ROM. Install this software as follows:

1. Make sure that there are no other Windows applications open during this installation procedure. Also, make sure that the computer meets the minimum requirements listed in the preceding section.
2. Insert the PCTrunk CD-ROM in the CD drive of your computer.

3. **Windows 3.1** - In the Program Manager, double click the SETUP.EXE file on the CD-ROM or click this file name and select File > Run.

**Windows 95/98/NT/2000** - Select Start > Settings > Control Panel and double click "Add/Remove Programs". Then click Install and Next. When SETUP.EXE is automatically located on the CD-ROM, click Next, select the location for the start-up icon, and enter the name you want to call the program.

4. Follow the instructions displayed by the setup program. The default directory for the program is \Program Files\PCTrunk. If you wish to use some other directory, click Browse and select it or type the name.

### 3.1.4 CONNECTING COMPUTER TO TRANSCEIVER

Connect Programming Cable, Part No. 023-5000-011, from the computer serial port to the accessory jack on the side of the transceiver. Since, this cable contains interface circuitry, an RPI is not required, and it has a female DB9 connector for connecting to the computer. This cable is available as part of the programming kit or separately (see Section 3.1.1).

### 3.1.5 STARTING AND EXITING

#### To Start PCTrunk From Windows 3.1

In the Program Manager, open the PCTrunk group window. Then double-click the PCTrunk icon.

#### To Start PCTrunk From Windows 95/98/NT

Click the Start button, select the PCTrunk group, and then click PCTrunk 5.xx.x.

#### To Exit PCTrunk:

Select File > Exit or press ALT + F4.

### 3.1.6 PROGRAMMING FILE TYPES

Programming data is stored in two disk files that can be saved, read, copied, and deleted (see Section

3.3.1). The two types that are stored for each programming session have the same name but different extensions as follows:

**Programming File (.DAT)** - Contains all programming information except what is in the following .460 file.

**Scrambling File (.460)** - Contains all information relating to the Transcript 460 scrambler. This file is saved only if this scrambling is used.

### 3.1.7 HELP FILES

To display help information on the current screen, click Help in the menu bar or press F1.

### 3.1.8 SCREEN GROUPS

#### General

The following screen groups are displayed:

**Radio-Wide** - These screens program parameters that are the same for all systems and channels. Separate screens are displayed for General, Conventional, SMARTNET/SmartZone, and Portable Options parameters. Refer to Section 3.4 for more information on these screens.

**System** - These screens program the parameters that are unique to the displayed Conventional, SMARTNET, or SmartZone system. The system to be edited is selected as described in Section 3.1.11.

**Channel** - This screen programs unique channel parameters and assigns channels to each zone. The specific parameters indicated in this screen are determined by the type of system selected in the "Type" box (Conventional Analog, Conventional Project 25, SMARTNET).

### 3.1.9 DISPLAYING SCREENS

The latest release of PCTrunk uses a different method of displaying screens. Proceed as follows to select which screens are displayed with the early and revised versions:

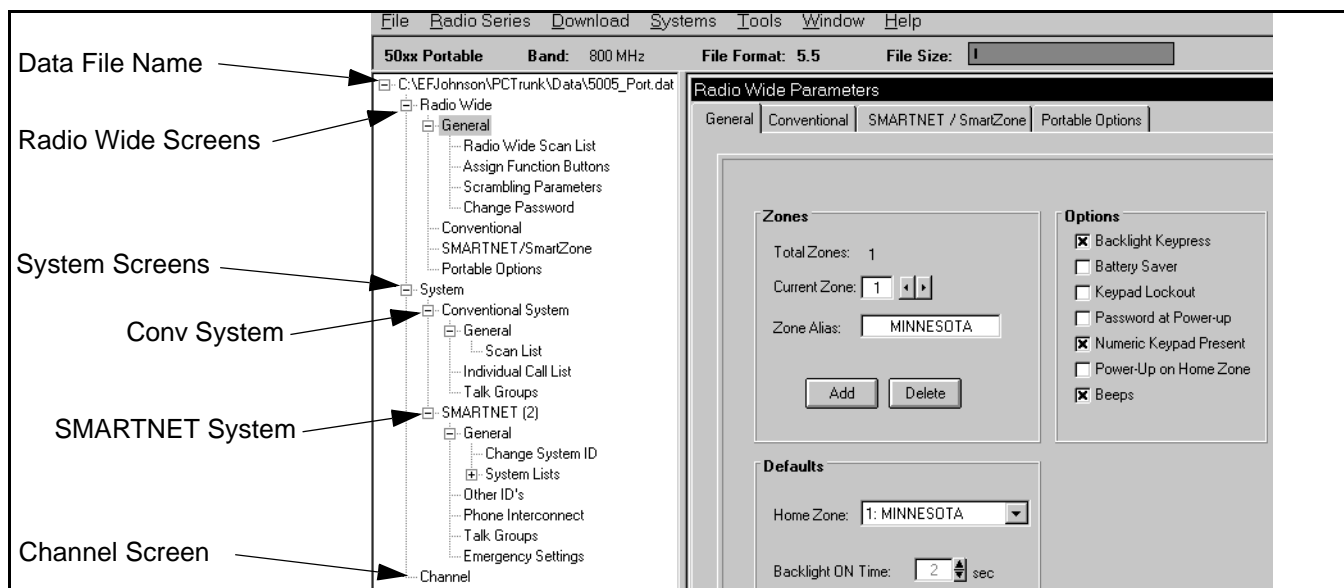

Figure 3-2 Main Screen (Later PCTrunk Versions)

Revised PC Trunk (Version 5.10.0 or Later)

Revised versions of PCTrunk use a pane on the left side of the screen (see Figure 3-2) to display the screen structure similar to the directory structure of a hard drive. Click the “+” to expand the branch and “-” to collapse it. Then to display a screen, simply click its name. The current screen may have to be closed in order to select another one.

Early PCTrunk (Versions Prior to 5.10.0)

With early versions of PCTrunk, the screens are displayed in cascade style or they can be minimized like any Windows screen. To cascade the active screens, select Window > Cascade from the menu bar.

To pop a screen to the front, click the applicable button shown below. For example, if the Channel screen is displayed and you want to quickly pop the Radio-Wide screen to the front, click the Radio-Wide button. These buttons can be displayed or hidden by clicking Window > Toolbar. A window can also be displayed by selecting it in the Window Menu.



Screen Pop-Up Buttons (Early PC Trunk Versions)

3.1.10 FILE SIZE INDICATOR

The maximum number of channels that can be programmed may be limited by the available memory space in the radio (see Section 1.2.5). A running indication of the amount of memory used by the current data if it was downloaded to the radio is displayed by a bar graph as shown in Figure 3-2 and the preceding illustration. When the bar reaches the right end, available memory is full and some channels may need to be deleted to program more information.

3.1.11 CREATING AND DISPLAYING SYSTEMS

To create a new SMARTNET or SmartZone system, select Systems > Add Systems and then the desired system type from the menu bar (see Section 3.3.7). This menu is also used to delete a system.

*NOTE: Only one conventional system can be set up, and it is automatically created when a new file is created as described in Section 3.2.1. Therefore, there is no option to add a conventional system.*

Only one system can be displayed at a time, so select the system to be edited as described in the preceding section. Systems are indicated by number and type. Channels or talk groups for all programmed systems are set up in the Channels screen. Therefore, any system can be selected when programming channel information.

### 3.2 PROGRAMMING PROCEDURE

The following is a general procedure you can use to program a transceiver.

#### 3.2.1 PRELIMINARY

1. Select a programming file as follows:

**Create a New File** - To start with a new file containing default parameters, select File > New and then the frequency band of the radio (VHF/ UHF/ 800 MHz).

**Open An Existing File** - To open an existing file stored on disk, select File > Open and then the file to be opened.

**Upload a File From a Radio** - To transfer a file from a radio to the computer to edit or use as a basis to program another radio, connect the radio to the computer as described in Section 3.1.4. Then turn the radio on and select Upload from the menu bar. Only the .DAT programming file is uploaded. The .460 scrambling file cannot be uploaded for security reasons.

2. Before or after creating the programming file, be sure the correct type (portable or mobile) is selected by the Radio Type menu (see Section 3.3.2).
3. A conventional system is automatically set up when a new programming file is created. If SMARTNET or SmartZone systems are also to be programmed, set them up as described in Section 3.1.11.

#### 3.2.2 PROGRAMMING RADIO WIDE PARAMETERS

1. To display a Radio Wide screen, click the screen name under Radio Wide in the left pane or click the Radio Wide button or select Window > Radio Wide (see Section 3.1.9).
2. Program the applicable information in these screens as described in Section 3.4.

#### 3.2.3 PROGRAMMING CONVENTIONAL SYSTEMS

*NOTE: If no conventional channels are to be programmed, skip this section.*

1. Make sure the conventional system is displayed by clicking it in the left pane or selecting Window > Conventional in the menu bar.
2. If required, display the Conventional System screen by clicking the System button or selecting Window > Conv System (see Section 3.1.9).
3. Program the conventional systems and channels as described in Section 3.5.

#### 3.2.4 PROGRAMMING SMARTNET AND SMARTZONE SYSTEMS

*NOTE: If no SMARTNET or SmartZone systems are to be programmed, skip this section.*

1. Make sure the desired SMARTNET or SmartZone system is displayed by clicking it in the left pane or selecting Window > SMARTNET or SmartZone in the menu bar.
2. If required, display the screens for that system by clicking the System button or selecting Window > Desired System (see Section 3.1.9).
3. Program the SMARTNET/SmartZone system and talk groups as described in Section 3.6.
4. To program additional SMARTNET/SmartZone systems, add a new system as described in Section 3.1.11 and repeat Section 3.6.

#### 3.2.5 PROGRAMMING RADIO (DOWNLOADING FILE)

When all the required programming information has been entered in the various programming screens, the information can be programmed (downloaded) into the radio. When downloading a file, be sure that all connections between the computer and radio are secure, the radio is turned on, and the proper serial port is selected (see Section 3.3.1). Then proceed as follows:

1. Select Download from the menu bar and then the file type to be transferred (programming or scrambling).
  - If the power-up password is enabled, the programming password must be entered to download or upload a file (see Section 3.7).
  - If a file is already loaded, the current file is transferred to the radio.
  - If no file is currently loaded, a dialog box appears to select the desired file.
2. Repeat for the other file type (if required).

*NOTE: The information which follows (Sections 3.3-3.6) provides detailed descriptions of the parameters that are displayed in the various PCTrunk screens.*

### 3.3 MENU COMMANDS

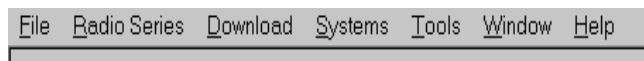

**Menu Bar**

#### 3.3.1 FILE MENU

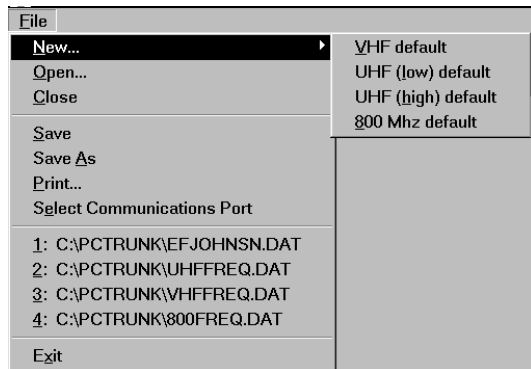

**New** - Creates a programming file with default parameters for the selected frequency range.

**Open** - Opens a programming file that was previously saved to disk. If a modified file is currently open, you are asked if that file should be saved before the new file is opened.

**Close** - Closes the current file. If the file has been modified and the changes have not been saved, you are asked if the changes should be saved before closing.

**Save** - Saves the current file to disk using the current file name.

**Save As** - Same as “Save” except you are prompted to enter a new file name if desired.

**Print** - Prints the information in the current file.

**Select Communications Port** - Displays the Communications Port dialog box which is used to select the serial port that is used to connect the transceiver to the computer (see Section 3.1.4).

**Exit** - Closes the PCTrunk program. If the current file has been modified and the changes have not been saved, you are asked if the changes should be saved before closing.

#### 3.3.2 RADIO SERIES MENU



The Radio Series menu shown above selects the radio being programmed. Select “50xx Portable”.

#### 3.3.3 DOWNLOAD MENU

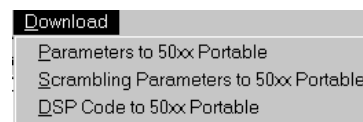

*NOTE: If the power-up password is enabled as described in Section 3.4.2, the programming password must be entered to download a file. Refer to Section 3.7 for more information on passwords.*

**Parameters to 50xx Series Portable** - Transfers the current programming file to the radio connected to the computer.

**Scrambling Parameters to 50xx Series Portable** - Transfers the selected scrambling parameters file to the radio connected to the computer.

**DSP Code to 50xx Series Portable** - Used along with the proper data file to update the radio operating software.

### 3.3.4 UPLOAD MENU

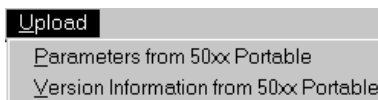

The Upload Menu is displayed only in the opening screen before a programming file is created. The following options are displayed:

**Parameters from 50xx Portable** - Transfers the programming data from a radio to the PCTrunk program. This data can then be viewed, edited, or saved to a disk file as desired. Scrambling parameters cannot be transferred out of a radio for security purposes.

**Version Information from 50xx Portable** - Displays the software version number and serial number of the connected radio.

### 3.3.5 SYSTEMS MENU



The Systems Menu is used to create new SMARTNET and SmartZone systems. It is also used to delete current systems. Conventional systems cannot be added because only one can be used and it is automatically created (see Section 3.1.11).

### 3.3.6 TOOLS MENU

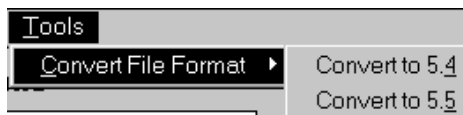

The Tools menu is used to convert files in Format 5.4 to Format 5.5 when applicable. For example, if a file is in Format 5.4 and new radios are purchased which use Format 5.5, it can be converted to the new format using this function.

### 3.3.7 WINDOW MENU

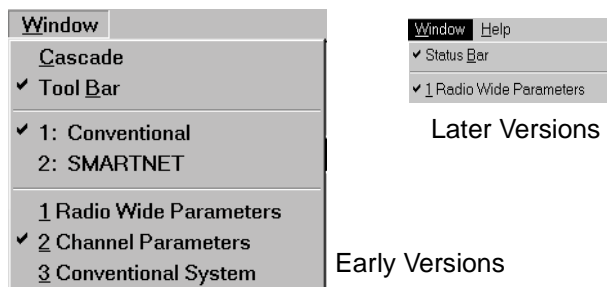

With early versions of PCTrunk, the Window Menu can be used to select the system to be edited and also to pop one of the screens to the front. With later versions, it is used only to turn the status bar on and off (see Section 3.1.9).

### 3.3.8 HELP MENU

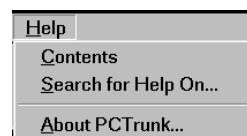

**Contents** - Displays the help system table of contents.

**Search For Help On** - Displays the search dialog box that allows searching for a help topic by keyword.

**About PCTrunk** - Displays the software version number of PCTrunk and the address of the E.F. Johnson Company.

## 3.4 RADIO-WIDE PARAMETER SCREENS

### 3.4.1 INTRODUCTION

The radio-wide screens program the parameters that are the same for all systems, channels, and zones. Separate screens are used for General, Conventional, SMARTNET/SmartZone, and Portable Options parameters. Refer to the information which follows.

### 3.4.2 RADIO-WIDE GENERAL SCREEN

#### Band

Displays the operating band selected by the File > New menu (see Section 3.3.1). The selected operating band must match that of the radio being programmed.

This parameter is displayed in the status bar with later PCTrunk versions (see Figure 3-2).

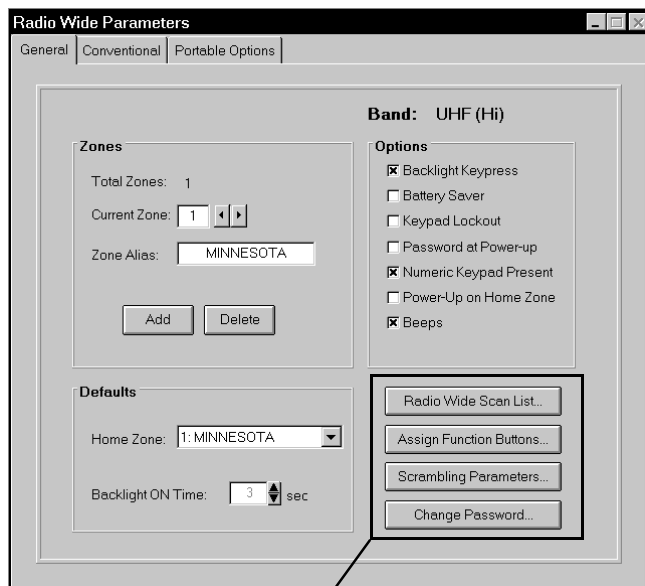

These screens selected in left pane w/version 5.10.0 or later.

### Radio-Wide General Screen

#### Zones

**Total Zones** - The total number of zones currently set up. The maximum number allowed is 16. Zones are added by clicking the Add button (see following).

**Current Zone** - Indicates the currently selected zone. To select another zone, click the up/down arrows.

**Zone Alias** - Edits the unique alpha identification for the displayed zone. Up to 10 characters can be entered. The zone alias is briefly displayed whenever a new zone is selected. Refer to Section 1.2.5 for more information on zones.

**Add (Zones) Button** - Adds another zone.

**Delete (Zones) Button** - Deletes the last zone added.

#### Defaults

**Home Zone** - Selects the zone that is selected by the Home Zone option switch if programmed.

**Backlight On Time** - Programs the length of time in

seconds that the backlight stays on after it is enabled by pressing a key (see following) or by the Backlight option switch.

#### Options

**Backlight Keypress** - If checked, the backlight turns on for the Backlight On Time whenever a key is pressed.

**Battery Saver** - If checked, the radio goes into a low current operating mode during periods of low activity to conserve battery power.

**Keypad Lockout** - If checked, the keypad is totally disabled and cannot be re-enabled by the user. All functions must then be assigned to keys on the side.

**Password at Power-Up** - If checked, the Password On Power-Up feature is enabled. Then each time power is turned on, the power-up password must be entered to operate the radio (see Section 3.7).

**Numeric Keypad Present** - This is checked if the transceiver is a 16-key (DTMF) model.

**Power Up On Home Zone** - If checked, the home zone is always selected at power-up.

**Beeps** - If checked, enables all tones. Otherwise, no tones sound (see Section 2.4.11).

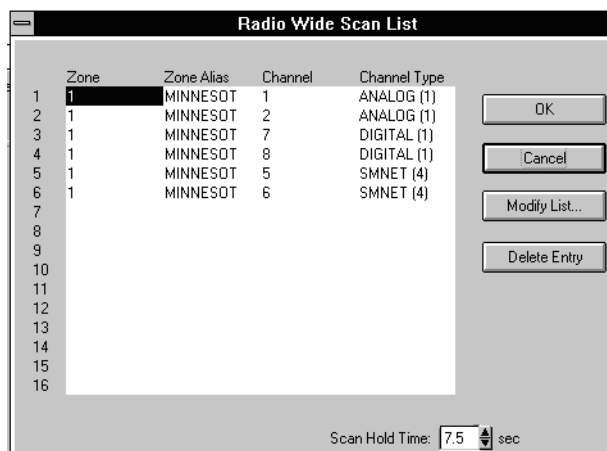

### Radio-Wide Scan List Screen

*NOTE: With PCTrunk, Version 5.10.0 or later, the following screens are selected by clicking their name in the left pane, not by clicking the button in the General screen.*

**Radio Wide Scan List Screen**

*NOTE: The radio-wide scan list cannot be programmed until all channels to be included have been set up as described in the Conventional and SMARTNET/SmartZone sections (3.5 and 3.6, respectively).*

Clicking the Radio Wide Scan List name in the left pane or that button in the General screen displays the preceding screen which programs the radio-wide scan list described in Section 2.5.6. The buttons and other parameters in this screen are as follows:

**Modify List... Button** - Displays the following screen that selects the channels in each Zone and System that are in this scan list. Select each Zone and then the channels to be included from that zone.

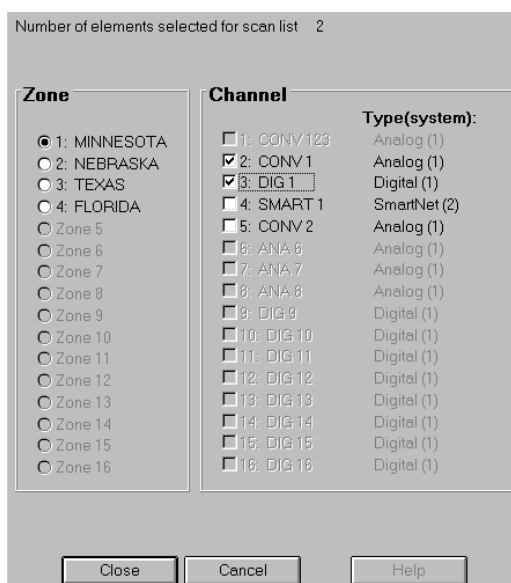

**Delete Entry** - Deletes the selected channel from the scan list.

**Scan Hold Time** - This programs the delay that occurs before radio-wide scanning resumes after a

message is no longer being received. Times of 0 - 7.5 seconds can be programmed (see Section 2.5.4).

**Assign Function Buttons Screen**

Clicking Assign Functions Buttons in left pane or that button in the General screen displays the option switches. The option switches can be programmed with a different set of functions for each operating mode (conventional, SMARTNET/SmartZone). For example, selecting a conventional channel enables the conventional functions and selecting a SMARTNET channel selects the SMARTNET functions. The functions that can be programmed for each mode are listed in Section 2.2.

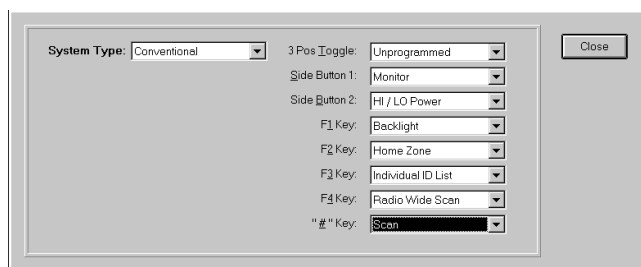

**Assign Function Buttons Screen**

Program the option switches as follows:

1. In the System Type pull-down menu, select the mode to be programmed (either conventional or SMARTNET/SmartZone).
2. To program a switch, click the arrow to display the pull-down menu and then select the desired function from that menu.
3. Repeat for all switches and modes to be programmed and then exit this screen by clicking the Close button.

**Scrambling Parameters Screen**

If 460 Scrambling is used (see Section 2.6.17), click the Scrambling Parameters button in the General screen to display the following screen. This screen programs scrambling and other signaling options, and the Codes screen modifies the list of scrambling codes which are stored in the radio. The buttons and other parameters in these screens operate as follows:



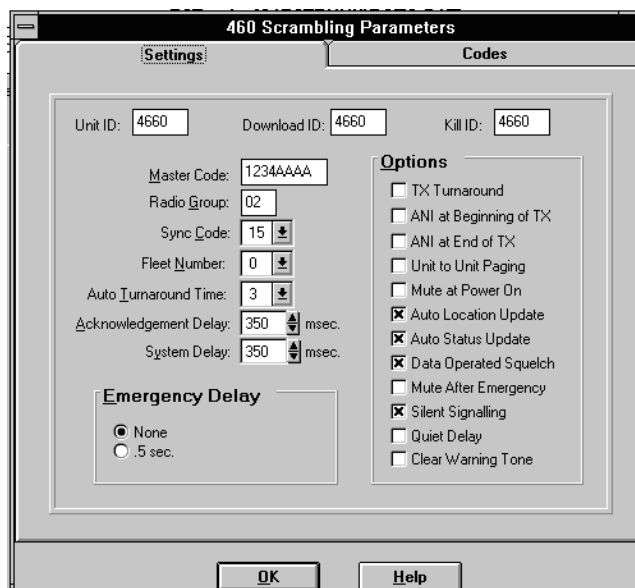

**460 Scrambler Settings Screen**

Settings Screen

Unit ID - Uniquely identifies the radio for Flashcall signaling.

Download ID - This ID must be received by the radio for it to accept a download of its scrambling parameters.

Kill ID - This ID must be received by the radio for the kill operation to occur.

Master Code - Displays the master code used by the scrambler. Two scramblers must be programmed with the same master code to communicate. The field is an 8-digit hexadecimal number (0-9, A-F).

Radio Group - Sets the group number of the scrambler from 00-99.

Sync Code - Scrambling sync code from 0-15. Two scramblers must have the same sync code to communicate.

Fleet Number - Number from 0-15 used when multiple fleets of scramblers are used.

Auto Turnaround Time - Time from 0-7 seconds after receiving a coded message that the scrambler ignores the clear code switch setting and forces the coded mode.

Acknowledgment Delay - Delay time from 50-1550 ms before the scrambler responds to information received from a controller.

System Delay - Delay time from 50-1550 ms between when the PTT switch is pressed and the scrambler transmits data over the air.

Emergency Delay - The amount of time the scrambler waits to send the emergency signal after the emergency switch is pressed. No delay or a 0.5 sec delay can be selected.

Tx Turnaround - If selected, inserts a delay between when scrambled information is received and then transmitted. This delay allows scramblers in the system to prepare for the new data.

ANI at Beginning of Tx - If selected, sends a Flashcall ANI at the beginning of every clear mode transmission.

ANI at End of Tx - If selected, sends a Flashcall ANI at the end of every clear mode transmission.

Unit-to-Unit Paging - If selected, enables a single unit page.

Mute at Power On - If selected, mutes the audio when powered up until the radio transmits, receives a Flashcall selective call, or OTAR reprogramming of scrambling parameters.

Auto Location Update - If selected, causes the scrambler to automatically send the user location every time it changes.

Auto Status Update - If selected, causes the scrambler to automatically send the user status each time it changes.

Data Operated Squelch - If selected, causes the scrambler to mute audio when incoming Flashcall data is received.

Mute After Emergency - If selected, causes the scrambler to mute the audio after sending an emergency signal until the unit transmits.

**Silent Signaling** - If selected, causes the scrambler to send a tone ahead of data packets that forces the receiving unit to mute its audio before the data burst is heard.

**Quiet Delay** - If selected, adds an extra 100 ms lead-in delay at the beginning of the silent signaling tone (if enabled).

**Clear Warning Tone** - If selected, sends a tone burst at 5-second intervals during clear mode transmissions. This alerts the listener that the conversation is not secure.

Codes Screen

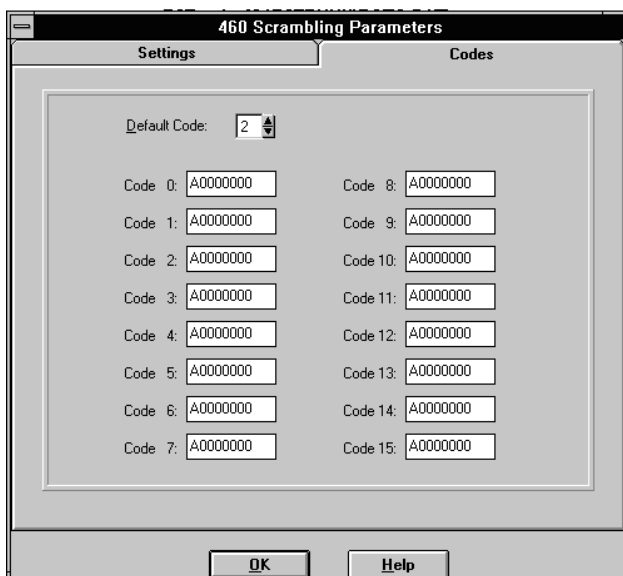

**460 Scrambler Codes Screen**

**Default Code** - Code space to use in the radio.

**Codes 0 - 15** - Edit the box to enter a code. All codes must begin with A0. The last six digits can be programmed for any value using hex digits 0-9, A-F.

**Change Password...** **Change Password Screen**

Displays the following screen which is used to change the Power-Up and Programming passwords. The default passwords are eight zeros (00000000). Refer to Section 3.7 for more password information. The power-up password function is utilized if “Password at Power Up” is checked on the Radio Wide General screen (see Section 3.4.2).



**Change Password Screen**

**3.4.3 RADIO-WIDE CONVENTIONAL SCREEN**

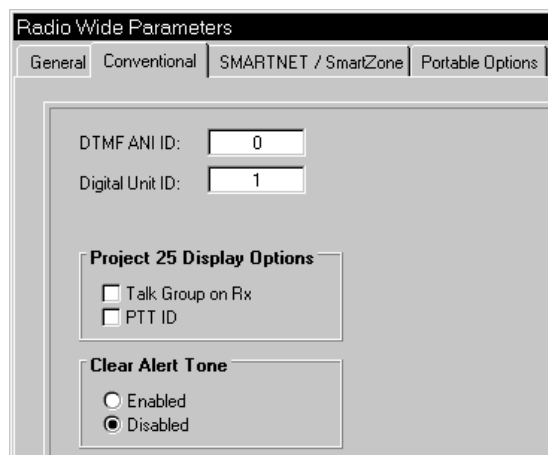

The radio-wide conventional screen is shown above, and it programs the following parameters:

**DTMF PTT ID** - The PTT ID is used on a channel programmed for pre- or post-transmit ANI. This ID consists of eight digits from 0-9.

**Digital Unit ID** - When operating on a Project 25 (digital) channel, this number identifies the radio. Each radio must have a different ID, and it must be between 1 and 16777216.

**Project 25 Display Options**

These functions select what is displayed when individual calls are received. If neither function is selected, the selected talk group alias or channel number is displayed (see “Individual Calls” in Section 2.6.16). With group calls, the talk group or channel number is always displayed.

Talk Group on Rx - The alias of the talk group on which the call is being received is displayed.

PTT ID - The ID of the mobile placing the call is displayed.

**Clear Alert Tone** - If it is enabled, a short beep sounds to indicate the clear (non encrypted) mode is selected. This tone sounds with SecureNet and digital OFB encryption only (not with 460 encryption).

### 3.4.4 RADIO-WIDE SMARTNET/SMARTZONE SCREEN

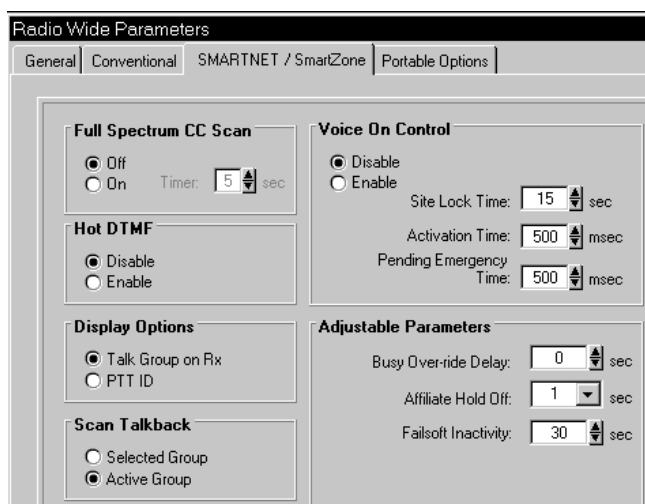

The radio-wide SMARTNET/SmartZone screen is shown above, and it is used to program these parameters:

#### Full Spectrum CC Scan

In a SmartZone system, if all potential control channel frequencies have been searched, the radio enters a channel-by-channel search across the full spectrum that the radio covers. The timer sets the time it performs this scan before it checks the expected frequencies again. After it checks these frequencies, it returns to full spectrum scanning. This cycle repeats until a control channel is found.

On-Off - Enables or disables full spectrum scan.

Timer - Sets the time that full spectrum scanning occurs as just described.

#### Hot DTMF

Enable/Disable - When enabled, allows the user to send DTMF tones while transmitting. When disabled, pressing numeric keys (0-9, \*, #) while transmitting has no affect. This option is not functional with SecureNet operation.

#### Display Options

See description in Section 3.4.3.

#### Scan Talkback

When a message is received when scanning, this determines if the response always occurs on the selected talk group or the talk group of the call (when not the same).

#### Voice On Control

With SmartZone operation, some remote sites are designated Voice On Control sites. In these sites, if all available traffic channels are occupied, control channels become traffic channels when additional traffic channels are requested. The Voice On Control parameters determine how the radio reacts to various situations that may occur. For example, when a conversation is complete, the radio may look for a control channel that has become a traffic channel.

Enable/Disable - Determines if the voice on control parameters are active.

Site Lock Time - This is the amount of time a radio remains on the Voice On Control site before looking for another site.

Activation Time - This is the amount of time the radio waits when the control channel comes back from Voice On Control before it transmits any pending ISWs. This prevents all radios on a Voice On Control site from submitting ISWs at the same time.

Pending Emergency Time - This is the amount of time the radio waits to submit an Emergency ISW after the control channel returns from the Voice On Control mode.

### Adjustable Parameters

Busy Override Delay - With SmartZone operation, this is the amount of time a user must press the PTT switch to override a SmartZone busy that occurs because some member of the talk group is present at a site where there are no traffic channels available.

Affiliate Hold Off - With SmartZone operation, this is the delay time that occurs after acquiring the control channel before it sends an affiliation ISW. This prevents all radios on the system from sending affiliation ISWs at the same time.

Failsoft Inactivity - Programs failsoft operation (see Section 2.7.11). If the radio remains inactive (no receive or transmit activity on channel) while operating in the failsoft mode for the programmed time, the radio momentarily leaves the failsoft mode and attempts to find a control channel. If “0” is programmed, the radio does not leave the failsoft mode.

#### 3.4.5 RADIO-WIDE PORTABLE OPTIONS SCREEN

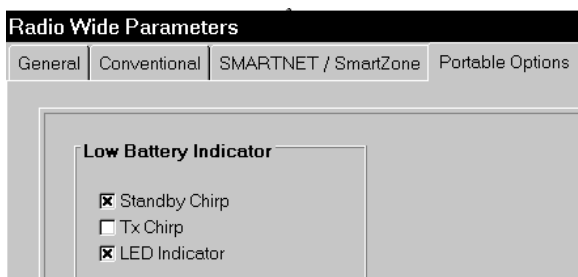

The radio-wide Portable Options screen is shown above, and it is used to program these parameters:

Standby Chirp - If this box is checked, a chirp sounds periodically in the standby mode while a low battery condition is being detected.

Tx Chirp - If this box is checked, a chirp sounds each time the PTT switch is pressed while a low battery condition is being detected.

LED Indicator - If this box is checked, the LED on the top panel indicates a low battery condition (green in standby, flashing red in transmit).

### 3.5 PROGRAMMING CONVENTIONAL SYSTEMS AND CHANNELS

#### 3.5.1 INTRODUCTION

The following information describes how to program conventional channels (both analog and Project 25). Only one conventional system can be programmed, and it is automatically set up when the programming file is selected as described in Section 3.1.6. Up to 256 conventional channels can be programmed (if no SMARTNET/SmartZone systems are programmed). Refer to Section 1.2.5 for more information on systems and channels.

The following is the recommended procedure for programming conventional channels:

1. Program the radio-wide information as described in Section 3.4.
2. If other types of systems have been programmed, make sure the conventional system is selected in the left pane or by selecting Window > Conventional in the menu bar (see Section 3.1.11).
3. Program the conventional system information and then the channel information as follows (both analog and Project 25 digital channels).

#### 3.5.2 CONVENTIONAL SYSTEM GENERAL SCREEN

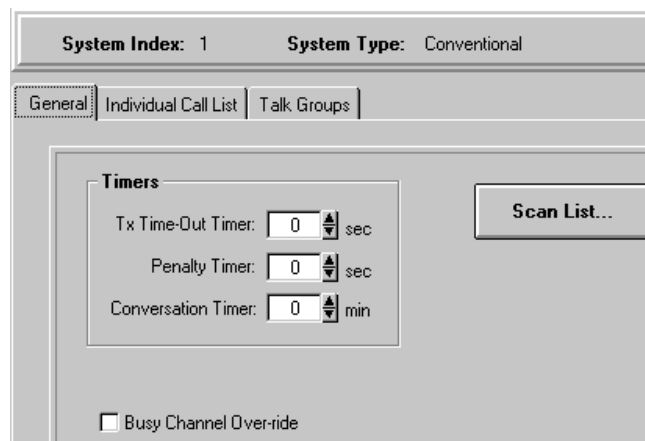

The conventional system General screen is shown above, and it programs the following parameters: