

Acclarix LX3 Series

Diagnostic Ultrasound System
Version 1.2

User Manual

Basic Volume

CE₀₁₂₃



About This Manual

P/N:01.54.458509

MPN: 01.54.458509012

Release Date: August, 2020

© Copyright EDAN INSTRUMENTS, INC. 2020

This User Manual applies to 1.0X releases for Acclarix LX3 series Diagnostic Ultrasound Systems including Acclarix LX3, Acclarix LX3 Exp, Acclarix LX3 Super, Acclarix LX25 and Acclarix LX28 models. See Appendix A.10 for the difference between these models.

This User Manual Basic Volume together with the User Manual Advanced Volume (P/N:01.54.458510) contain necessary and sufficient information to use the Acclarix LX3 series Diagnostic Ultrasound Systems safely for the intended purposes and approved clinical applications.

Please read and make sure you understand all of the instructions in this manual prior to using the system. Disregarding instructions, particularly warnings and cautions, is considered abnormal use.

Not all measurements and features are available for all system models and configurations. This manual is based on the complete set of transducers and features available. Therefore, some of the contents may not apply to your product. If you have any questions, please contact your local EDAN representative. The pictures and interfaces in this manual are for reference only.

Conventions

In this manual, the following conventions are used to describe the system for better understanding:

- ***Bold***: bold texts indicate keys or items on main screen or touch screen.
- ***<Bold>***: bold texts in angular brackets indicate buttons, knobs and other controls on the console or on the keyboard.
- ***->***: Arrow indicates operations following the path.

Contact Information

For sales or service information, please contact your local distributor or the EDAN Service Department at: support@edan.com

Contents

1	Introduction	1
1.1	Intended Use/ Indications for Use	1
1.2	Contra-indications	1
1.3	Device Description	1
2	Safety	2
2.1	Warnings	2
2.2	Cautions	4
2.3	Labeling Symbols	7
3	Getting Started	11
3.1	System Configuration	11
3.2	System Overview	14
3.2.1.	Main Unit	14
3.2.2.	Control Panel	19
3.2.3.	Screen Layout	23
3.2.4.	Touch Screen	26
3.2.5.	Trackball	27
3.3	System Preparation	28
3.3.1.	Battery Use	28
3.3.2.	AC Power Use	30
3.3.3.	Transducer Connection	30
3.3.4.	Powering on/ off	31
3.4	Monitor Position Adjustment	32
3.5	Control Panel Height Adjustment	33
4	Exam Operation	34
4.1	How to Start an Exam	34
4.2	How to End an Exam	35
4.3	How to Restart an Exam	35
4.4	The Patient Information Page	35
4.5	Modality Worklist	38
5	Imaging	39
5.1	B-mode	39
5.1.1.	Using B-mode	39
5.1.2.	B-mode Image Optimization	39
5.2	Color Mode	42
5.2.1.	Color Mode Variants	42
5.2.2.	Using Color Mode	42
5.2.3.	Color Image Optimization	42
5.3	PW Mode	45
5.3.1.	Using PW Mode	45

5.3.2. PW Image Optimization.....	45
5.3.3. HPRF	47
5.4 CW Mode	48
5.4.1. Using CW Mode	48
5.4.2. CW Image Optimization.....	48
5.5 M-mode	50
5.5.1. Using M-mode	50
5.5.2. M-mode Image Optimization	50
5.6 Anatomic M Mode.....	52
5.6.1. Using Anatomic M Mode.....	52
5.6.2. Optimizing Anatomic M Image.....	52
5.7 TDI Mode.....	53
5.7.1. Using TDI mode	53
5.7.2. TDI Image Optimization.....	53
5.8 3D/4D Mode	54
5.8.1. Pre-3D/Pre-4D.....	54
5.8.2. 3D Volume Sweeping	55
5.8.3. 3D Image Review	55
5.8.4. 4D Volume Acquisition.....	60
5.8.5. 4D Live Volume	60
5.8.6. 4D Cine	61
5.8.7. Knobs and Buttons on Control Panel	62
6 Transducers and Biopsy	63
6.1 Transducers.....	63
6.2 Using Transducers	65
6.3 Transducer Cleaning and Disinfecting	68
6.3.1. Cleaning	68
6.3.2. Disinfecting.....	68
6.3.3. Sterilization.....	71
6.3.4. Storage.....	71
6.4 Needle Biopsy Guide	72
6.4.1. Installing Needle Guide Bracket	72
6.4.2. Activating Needle Guide Function	77
6.4.3. Calibrating the Needle Guide Line.....	78
6.5 Needle Visualization.....	79
6.6 Center Line.....	80
6.7 Needle Guide Bracket Cleaning and Sterilization	80
6.7.1. Cleaning	80
6.7.2. Sterilization.....	81
6.7.3. Storage.....	81
7 Features.....	82

7.1 Comment.....	82
7.2 Body Mark	84
7.3 Split Display.....	85
7.3.1. Dual Imaging	85
7.3.2. Quad Imaging.....	85
7.4 Zoom	86
7.5 Cine Review	86
8 Measurements and Reports.....	88
8.1 Generic Measurements.....	91
8.1.1. B-mode Generic Measurements.....	91
8.1.2. M-mode Generic Measurements	94
8.1.3. Strip Doppler Generic Measurements	95
8.2 Application Measurements	100
8.2.1. Abdomen Measurements.....	101
8.2.2. Gynecology Measurements.....	102
8.2.3. Obstetrics Measurements.....	103
8.2.4. Cardiac Measurements	106
8.2.5. Small Parts Measurements	110
8.2.6. Urology Measurements	111
8.2.7. Vascular Measurements.....	112
8.2.8. Pediatric Measurements.....	115
8.3 Worksheet and Report	117
8.3.1. Worksheet	117
8.3.2. OB Worksheet.....	118
8.3.3. Growth Curve	119
8.3.4. Findings.....	122
8.3.5. Report	123
8.4 Measurement Accuracy	124
9 Exam Data Management.....	125
9.1 Storing Images	125
9.2 Reviewing Images.....	126
9.3 Exam Database.....	127
9.4 Archiving Studies.....	129
10 Presets.....	130
10.1 Preset Organization	130
10.2 Selecting a Preset.....	131
10.3 Storing and Editing a Preset	131
10.3.1. Exam Preset.....	132
10.3.2. Image Preset.....	133
10.3.3. Comment Preset	134
10.3.4. Body Mark Preset.....	136

10.3.5. Measure Preset	137
11 Utilities	139
11.1 System Set-up	139
11.1.1. General Set-up	139
11.1.2. Patient Set-up	141
11.1.3. Store/Print Set-up	142
11.1.4. Report Set-up	143
11.1.5. Image Set-up	144
11.1.6. Power Set-up	145
11.1.7. User Set-up	146
11.2 Connectivity	147
11.2.1. TCP/IP	148
11.2.2. DICOM	149
11.3 Maintenance	151
11.3.1. License	151
11.3.2. Version	152
11.3.3. Demo	152
11.3.4. Self-Check	154
11.3.5. Tool	154
11.4 Screen Adjust	155
12 In Between Exams	156
12.1 Unpacking	156
12.2 Transport	156
12.3 Storage	156
13 Troubleshooting and Maintenance	157
13.1 Daily Checklist	157
13.2 Troubleshooting	157
13.3 System Cleaning and Disinfection	158
13.4 Maintenance	160
Appendix A Specifications	161
A.1 Electrical Safety Classifications	161
A.2 Power Supply	161
A.3 Battery	161
A.4 Machine Specifications	161
A.5 Display Specifications	162
A.6 General Specifications	162
A.7 Wi-Fi Specifications	163
A.8 Operating, Storage and Transportation Environment	164
A.8.1 Operating Environment	164
A.8.2 Storage and Transportation Environment	164
A.9 Transducer Specifications	164

A.10 Configuration Difference	164
Appendix B Ultrasound Intensity and Safety	165
B.1 Ultrasound in Medicine	165
B.2 Ultrasound Safety and the ALARA Principle.....	165
B.3 Explanation of MI/TI.....	166
B.3.1 MI (Mechanical Index)	166
B.3.2 TI (Thermal Index)	166
B.3.3 Display of MI/TI.....	167
B.4 Acoustic Output	167
B.4.1 Factors that Contribute to Uncertainty in the Output Display	167
B.4.2 Differences between Actual and Displayed MI/TI.....	167
B.4.3 Measurement Uncertainty.....	167
B.4.4 Acoustic Power Default Settings.....	168
B.4.5 Acoustic Output Limits	168
B.5 Operator Control Features.....	168
B.6 Prudent Use Statement	168
B.7 References for Acoustic Output and Safety.....	169
B.8 Transducer Acoustic Output Data.....	169
Appendix C Order List.....	170
Appendix D EMC Information	172
Appendix E Ultrasound Gel Warmer	177

1 Introduction

1.1 Intended Use/ Indications for Use

The Acclarix LX3 series Diagnostic Ultrasound System is intended for use by a qualified physician or allied health professional for ultrasound evaluations in hospitals and clinics. General clinical applications include: Abdominal, Gynecology, Obstetric, Cardiac, Small parts, Urology, Musculoskeletal, Peripheral vascular, Intra-operative, Pediatric, Neonatal, Adult Cephalic.

The modes of operation for Acclarix LX3 series include B mode, M mode, Doppler mode, Harmonic Imaging, and their combination modes.

1.2 Contra-indications

The Acclarix LX3 series Diagnostic Ultrasound System is not intended for ophthalmic use or any use causing the acoustic beam to pass through the eye.

1.3 Device Description

The Acclarix LX3 series Diagnostic Ultrasound System consists of a main system and associated ultrasound transducers.

The system circuitry generates an electronic voltage pulse, which is transmitted to the transducer. In the transducer, a piezoelectric array converts the electronic pulse into an ultrasonic pressure wave. When coupled to the body, the pressure wave transmits through body tissues. The waves are then reflected within the body and detected by the transducer, which then converts the waves back to an electrical signal. The system then analyzes the returned signals and generates an ultrasound image or spectral Doppler display.

The Diagnostic Ultrasound System provides the operator the ability to measure anatomical structures, and offers analysis packages that provide information used by competent health care professionals to make a diagnosis.

The system's user interface provides both hard keys for functions frequently used throughout an exam and touch screen controls for mode-specific functions.

2 Safety

Throughout this document the following terms are used:

- **Warning:** Advises against certain actions or situations that could result in personal injury or death.
- **Caution:** Advises against actions or situations that could damage equipment, produce inaccurate data, or invalidate a procedure.
- **Note:** Provides useful information regarding a function or a procedure.

Please read all warnings and cautions prior to using the system. For your convenience, all warnings and cautions are provided in this section, but may be duplicated elsewhere in this document in the context of the instructions for use.

2.1 Warnings

- Only use Edan supplied power cord.
- Only use Edan supplied battery. Read and understand the battery installation instructions prior to changing the battery.
- Only use Edan supplied transducer. Use of other transducers may result in electric shock or system malfunction.
- Only use a hospital grade, grounded, power outlet and plug. Do not use with an ungrounded outlet.
- The system is ordinary equipment (sealed equipment without liquid proof). The transducers (not including transducer connector) is IPX7 certified. The footswitch is IP68 certified. Do not immerse or expose any of the parts to extended moisture. Splash resistance does not extend to transducer connectors. Please keep connectors dry.
- Do not use in a wet environment or when the relative humidity exceeds 95%.
- Do not reverse the positive and negative poles when installing the battery.
- Do not use the battery near heat sources or when the ambient temperature is over 40°C. Do not heat or dispose of in fire.
- Do not destroy the battery; do not pierce or cause a strong impact to the battery.
- Do not touch the connector pins on the transducer port.
- Parts and accessories used must meet the requirements of the applicable IEC/EN60601 series safety standards, and/or the system configuration must meet the requirements of the IEC/EN60601-1.
- Use protective barriers (gloves and transducer sheaths) whenever possible. Follow sterile procedures when appropriate. Thoroughly clean transducers and reusable accessories after each patient examination and disinfect or sterilize as needed. Refer to transducer use and care instructions. Follow all infection control policies established by your office, department or institution as they apply to personnel and equipment.
- Not intended for Ophthalmic use or any use causing the acoustic beam to pass through the eye.
- If a sterile transducer cover becomes compromised during an intra-operative application involving a patient with transmissible spongiform encephalopathy, such as Creutzfeldt-Jakob disease, follow the guidelines of the U.S. Disease Control Center and this document from the World Health Organization: WHO/CDS/APH/2000/3, WHO Infection Control Guidelines for Transmissible Spongiform Encephalopathies. The transducers for your system cannot be decontaminated using a heat process.

- Contact with natural rubber latex may lead to a severe anaphylactic reaction in persons sensitive to the natural latex protein. Sensitive users and patients must avoid contact with these items. EDAN strongly recommends that health-care professionals identify their latex-sensitive patients, and refer to the March 29, 1991 Medical Alert on Latex products. Be prepared to treat allergic reactions immediately.
- Improper operation may cause the internal lithium battery (hereinafter called battery) to become hot, ignited or possibly explode, and it may lead to decreased battery capacity. It is necessary to read the user manual instructions and warning messages carefully.
- Do not touch accessible contacts of electrical equipment and the patient simultaneously.
- This device is not suitable for intra-cardiac use or direct cardiac contact.
- The system shall not be serviced or maintained while in use with a patient.
- Install the system according the EMC guidance provided in Appendix D.
- Do not stack the system on other electronic equipment.
- The use of transducer and connecting cable not supplied by the manufacturer may result in increased emissions or decreased immunity of the equipment.
- Refer to Appendix D for recommended separation distances from other equipment, including portable and RF communication devices.
- The mains plug is used to isolate the system from main power. Position the system so that it is easy to disconnect it from the power supply.
- No modification of this equipment is allowed.
- The system should be maintained regularly, at least annually, by a qualified technician who has adequate training, knowledge and experience. That person should be familiar with the Service Manual, available from your Edan representative.
- Keep non-medical equipment out of the vicinity of the patient. (1.5m/6ft.)
- Use of an extension cord or multi-socket outlet setup to provide power to the ultrasound system or to the system's peripheral devices, may compromise the system grounding and cause the system to exceed current leakage limits.
- It is not suggested to use a multiple socket-outlet with the device. If one is required, make sure that the multi-socket complies with the requirement specified in Chapter 16 of IEC 60601-1, or the multi-socket is with an isolation transformer. And the multi-socket shall not be placed on the floor.
- SHOCK HAZARD - Don't connect electrical equipment, which has not been supplied as a part of the system, to the multiple portable socket-outlet supplying the system.
- SHOCK HAZARD - Don't connect non-electrical equipment, which has been supplied as a part of the system, directly to the wall outlet when the non-medical equipment is intended to be supplied by a multiple portable socket-outlet with an isolation transformer.
- SHOCK HAZARD – Do not connect non-isolated electrical equipment to the same circuit being used to power the system.
- Edan recommends the use of isolated connectors on any electrical equipment attached to the system, and/or using isolation transformers that comply with IEC60601-1 to power that electrical equipment.
- Always use sterile technique during a biopsy procedure. Sterilize the needle guide assembly between uses.
- Use a sterile needle with each use.
- The system may be interfered with by other equipment, even if that other equipment complies with CISPR EMISSION requirements.
- The system cannot be used together with high-frequency surgical equipment.

- Remove the battery from the device when the device is not used for a long time.

Transducer Warnings

- To avoid infection, always use protective gloves when cleaning or disinfecting.
- Read and follow all manufacturer instructions for disinfection agents.
- To avoid infection, ensure that expiration date of the disinfecting solution has not passed.
- Disinfect the transducer after each intra-cavity or intra-operative procedure. Use a new sterile sheath for each such procedure.
- Use a pyrogen-free transducer sheath for intra-operative procedures.
- The system is not intended to come into contact with the central nervous system and central cardiovascular system.
- Unplug the transducer from the system prior to cleaning or disinfecting.
- Do not immerse the transducer beyond the point indicated in Figure 6-3.
- Do not allow the transducer connector to get wet.
- "Intra-operation" exam preset must be used when doing intra-operative examination using transducer L17-7SQ.

2.2 Cautions

- Excessive dust and dirt could clog internal airflow and cause overheating. Do not use in a dusty environment.
- Do not use a battery that leaks, emits an odor, appears deformed, or discolored. Immediately replace it with a new Edan-supplied battery and dispose of the old battery according to local regulations. Replace a battery that has reached the end of its service life.
- Use care when storing or disposing of batteries. Do not allow the leakage from one battery to come in contact with other batteries. Batteries (including button cell on the main board) are hazardous waste. Do not dispose of them together with household garbage. At the end of their life hand the batteries over to the applicable collection points for the recycling of waste batteries. Inappropriate disposal of waste may contaminate the environment.
- Inspect the system regularly, at least weekly. Before use, ensure there is no visible evidence of damage to the equipment, cables, and transducers. If a component is damaged, replace it before use.
- Do not use in locations subject to vibration.
- Do not exert excessive vibrations onto the system. Otherwise, it may damage the mechanical components (such as wheels). If the system is required to move on an uneven surface frequently, consult EDAN or authorized representatives for service.
- Read and understand the section *Appendix B.2 Ultrasound Safety and the ALARA Principle* before using the system. Do not expose a patient to ultrasound energy longer than clinically reasonable.
- Practice ALARA principle when operating ultrasound system. Minimize the acoustic power without compromising the image quality.
- Do not use in the presence of a flammable anesthetic.
- The system generates radio frequency energy, which may cause interference with other devices in the vicinity. If interference is suspected, try re-orienting or relocating the equipment.
- The use of electrosurgical units or other devices that generate radio frequency interference may cause image distortion or other malfunctions.
- The system should only be used by a qualified physician or allied health professional for ultrasound evaluations.

- Use only Edan supplied or recommended parts and accessories.
- Verify measurement results prior to entering them into a report.
- Contact your local distributor or Edan Service if there is excessive noise from the system speaker or fans.
- Please read and understand cleaning instructions prior to use.
- Please read and understand maintenance instructions prior to use.
- Please read and understand instructions for system operation prior to use.
- Studies stored on the system hard drive should be archived regularly. The system is not intended for long term storage of patient information. Confirm successful archiving before deleting a study from the hard drive.
- Ensure that the system vents are clear and unobstructed.
- Confirm patient identification information prior to storing or printing any exam information.
- If you have any questions about maintenance, technical specifications, or system functionality, please contact your local distributor or Edan Service at: support@edan.com.
- Ultrasound images occasionally have artifacts, and should only be used as one part of an overall clinical assessment.
- To avoid electrical shock, turn off and disconnect the device from the AC power source before cleaning and disinfecting.
- No user serviceable parts are inside the system. All repairs on the system must be performed by EDAN certified service personnel.
- The device and accessories are to be disposed of according to local regulations after their useful lives. Alternatively, they can be returned to the dealer or the manufacturer for recycling or proper disposal.
- The packaging is to be disposed of according to local or hospital's regulations; otherwise, it may cause environmental contamination. Place the packaging at a location that is inaccessible to children.
- Properly dispose of used cleaning agents or disinfectants according to your hospital's regulations.
- The system does not need calibration as part of routine maintenance.
- The format of U disk should be FAT32.
- Do NOT place the device on slopes. It may suddenly slide, resulting in injury and/or equipment damage.
- Do NOT stand/sit on or bend over the device. It may move and make you lose your balance and tumble.
- To ensure safety, two persons are required to move the device across slopes.
- Any serious incident that has occurred in relation to the device should be reported to the manufacturer and the competent authority of the Member State in which the user and/or patient is established.

Transducer Cautions

- Do not use disinfection agents beyond their expiration date.
- Do not use sterile sheaths beyond their expiration date.
- Inspect the transducer connector, cable, and head periodically. Do not use if there is evidence of excessive wear or damage.
- Do not operate the transducer to temperatures in excess of 40°C or store the transducer in temperatures in excess of 55°C.

- Do not kink or pull on the transducer cable.
- Broken or bent connector pins can cause image artifacts. Do not use a transducer with broken or bent pins.

Network Security Cautions

- Keep your ultrasound system safe to protect the patient information and data from being modified, damaged or disclosed caused by unauthorized disassembly.
- Always ensure the privacy of patient information and data displayed/stored in the ultrasound system or exported to external storage devices.
- The software upgrade can only be performed by EDAN-qualified service professionals with upgrade files of known provenance. Confirm that the system boots to imaging after an upgrade.
- Make sure the ultrasound system is used under secure network environment, and all the approved devices connecting with the ultrasound system are physically secure.
- Anti-virus measures such as USB device virus scanning should be carried out prior to using the USB flash drive.
- Do not connect an USB device with unknown provenance to the ultrasound system.
- When the ultrasound system is returned for maintenance, disposed of, or removed from the medical institution for other reasons, ensure all patient data are removed from the ultrasound system.
- Always hide your password when entering it on the system, protecting it from being disclosed.

Federal Communications Commission (FCC) Statement:

This device complies with Part 15 of the FCC Rules. Operation is subject to the following two conditions:

- This device may not cause harmful interference, and
- This device must accept any interference received, including interference that may cause undesired operation.

This equipment has been tested and found to comply with the limits for a Class B digital device, pursuant to part 15 of the FCC Rules. These limits are designed to provide reasonable protection against harmful interference in a residential installation. This equipment generates uses and can radiate radio frequency energy and, if not installed and used in accordance with the instructions, may cause harmful interference to radio communications. However, there is no guarantee that interference will not occur in a particular installation. If this equipment does cause harmful interference to radio or television reception, which can be determined by turning the equipment off and on, the user is encouraged to try to correct the interference by one or more of the following measures:












- Reorient or relocate the receiving antenna.
- Increase the separation between the equipment and receiver.
- Connect the equipment into an outlet on a circuit different from that to which the receiver is connected.
- Consult the dealer or an experienced radio/TV technician for help.














This equipment complies with FCC radiation exposure limits set forth for an uncontrolled environment. This equipment should be installed and operated with minimum distance 20cm between the radiator & your body.

Any changes or modifications not expressly approved by the party responsible for compliance could void the user's authority to operate the equipment.

2.3 Labeling Symbols








The following labels are used on the system:

No.	Symbol	Definition
1		Serial Number
2	<i>P/N</i>	Part Number
3		Date of Manufacture
4		Manufacturer
5		Operating instructions
6		Warning (Background: Yellow; Symbol & outline: Black)
7		Refer to instruction manual/ booklet (Background: Blue; Symbol: White)
8		Caution
9		CE Marking
10		Authorized Representative in the European Community
11		Disposal method. Indicates that the equipment should be sent to special agencies according to local regulations for separate collection after its useful life.
12	<i>Rx only</i>	Caution: Federal (U.S.) law restricts this device to sale by or on the order of a physician.
13	IPX7	Protected against the effects of temporary immersion in water.
14		Type BF Applied Part

15		Probe for sector-shaped sound field
16		Locking, general
17		Unlocking
18		Equipotentiality
19		Computer network
20	EDAN	Trademark
21		Video output
22		USB 2.0 port
23		USB 3.0 port
24	HDMI	HDMI port
25		Alternating Current
26		Battery check
27		Non-ionizing electromagnetic radiation
28		Non-sterile. Indicates a medical that has not been subjected to a sterilization process.
29	IP68	Dust-tight (No ingress of dust); Protected against the effects of continuous immersion in water.
30		Pushing prohibited.

31	<i>FCC ID:SMQLX3EDAN</i>	Federal Communications Commission: FCC ID:SMQLX3EDAN
----	---------------------------------	---

The following labels are used on the packaging:

No.	Symbol	Definition
1		This way up
2		Fragile, handle with care
3		Keep dry
4		Stacking limit by number
5		Do Not Roll.
6		General Symbol for Recovery / Recyclable
7		Tilt Watch Indicator.

NOTE:

The user manual is printed in black and white.

3 Getting Started

3.1 System Configuration

Standard Configuration:

The system is shipped with the following components:

- ◆ 1 main unit
- ◆ 1 power cord
- ◆ 1 potential equalization conductor
- ◆ 1 bottle of coupling gel
- ◆ 1 basic user manual and 1 advanced user manual
- ◆ 1 packing list

Options:

The following options are also available:

- ◆ Transducers:
L17-7HQ, E8-4Q, C5-2Q, L12-5Q, L17-7SQ, MC8-4Q, P5-1Q, P7-3Q, MC9-3TQ, C7-2XQ, E10-3BQ, E10-3HQ, C6-2MQ, C5-1Q.
- ◆ Needle Guide Bracket Kit

<i>Model</i>	<i>Type</i>	<i>Angle/Depth</i>	<i>Description</i>
BGK-C5-2	In-plane	20° , 28° , 40°	For use with the C7-2XQ, Supports: 14G-23G
BGK-CR10UA	In-plane	2°	For use with the E8-4Q, Supports: 16G, 18G
BGK-002	In-plane	38° , 46° , 58°	For use with the L12-5Q/L17-7HQ, Supports: 14G-23G
BGK-003	Out-of-plane	1.0cm, 1.5cm, 2.0cm	For use with the L12-5Q/L17-7HQ, Supports: 21G
BGK-004	In-plane	12° , 20°	For use with the MC9-3TQ, Supports: 14G-23G
BGK-005	In-plane	0°	For use with the E10-3BQ, Supports: 16G, 18G
BGK-006	In-plane	1°	For use with the E10-3HQ, Supports: 16G, 18G
BGK-007	In-plane	18° , 25° , 35°	For use with the C5-2Q, Supports: 14G-23G

BGK-008	In-plane	12° , 22°	For use with the P5-1Q Supports: 14G-23G
BGK-009	In-plane	14° , 20° , 32°	For use with the C5-1Q Supports: 14G-23G
BGK-012	In-plane	11° , 20° , 37°	For use with the MC8-4Q Supports: 14G-23G

Table 3-1 Needle Guide Bracket Kits

- ◆ Footswitch
- ◆ USB disk
- ◆ Batteries
- ◆ Ultrasound gel warmer

Supported Peripheral Accesories:

- ◆ The recommended local printers are listed as follows:

<i>Printer Type</i>	<i>Printer Model</i>	<i>Interface</i>
Color Video Printer	SONY UP-25MD	S-Video
	SONY UP-D25MD	USB
B/W Video Printer	SONY UP-X898MD	USB
	Mitsubishi P95	USB
Report Printer	HP LaserJet CP1525n Color	USB
	HP Deskjet Ink Advantage 2010	USB
	HP Deskjet 1010	USB
	HP Deskjet 1510	USB
	HP DeskJet Ink Advantage Ultra 2029	USB
	HP DeskJet 1112	USB
	Canon iP2780	USB
	HP LaserJet Pro MFP M126nw	USB
	EPSON L310	USB
	HP DeskJet 1050	USB
	HP DeskJet 2050	USB
	HP LaserJet M252n	USB
	EPSON L130	USB

Table 3-2 Printer List

WARNING

Only the recommended printers listed above are verified by EDAN. Therefore, it is suggested to only

use these printers. Use of other printers should comply with IEC 60950 or IEC 60601-1. Edan is not responsible for the accuracy of other printers.

- ◆ Recommended DVD drives: LITEON eBAU108.

3.2 System Overview

3.2.1. Main Unit

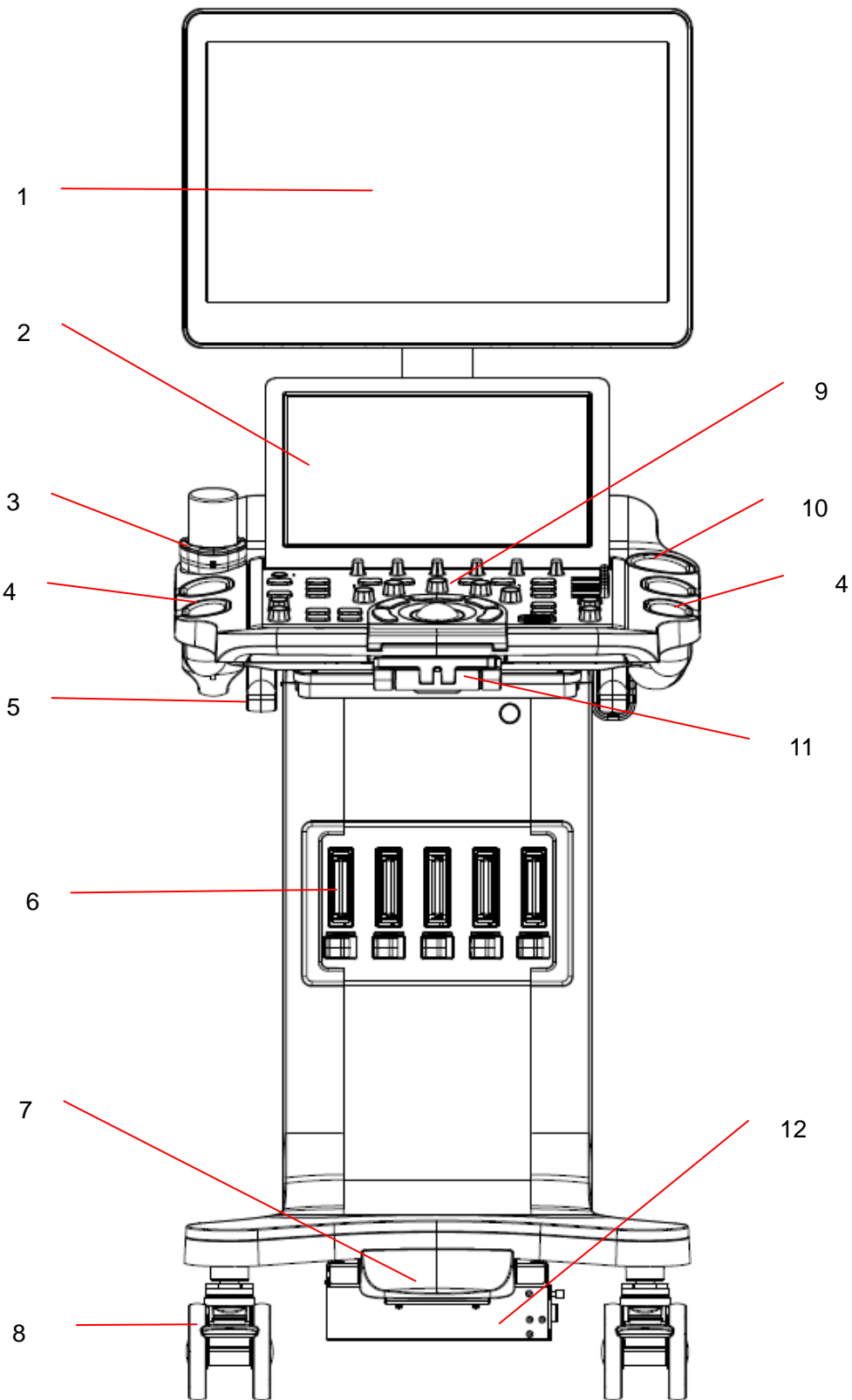


Figure 3-1 Front View

No.	Description	No.	Description
1	21.5" LCD Monitor	7	Pedal for control panel height adjustment
2	14" Touch Screen	8	Wheels(four)
3	Coupling Gel Holder/ Gel Warmer(optional)	9	Control Panel
4	Transducer Holders	10	Endo-cavity Transducer Holder
5	Cable Holder	11	Physical Keyboard
6	Transducer Sockets(five)	12	Power Unit/Battery Compartment

Table 3-3 Front View Description

Overturn the physical keyboard on figure 3-1 to open the keyboard for editing.



Figure 3-2 System Keyboard

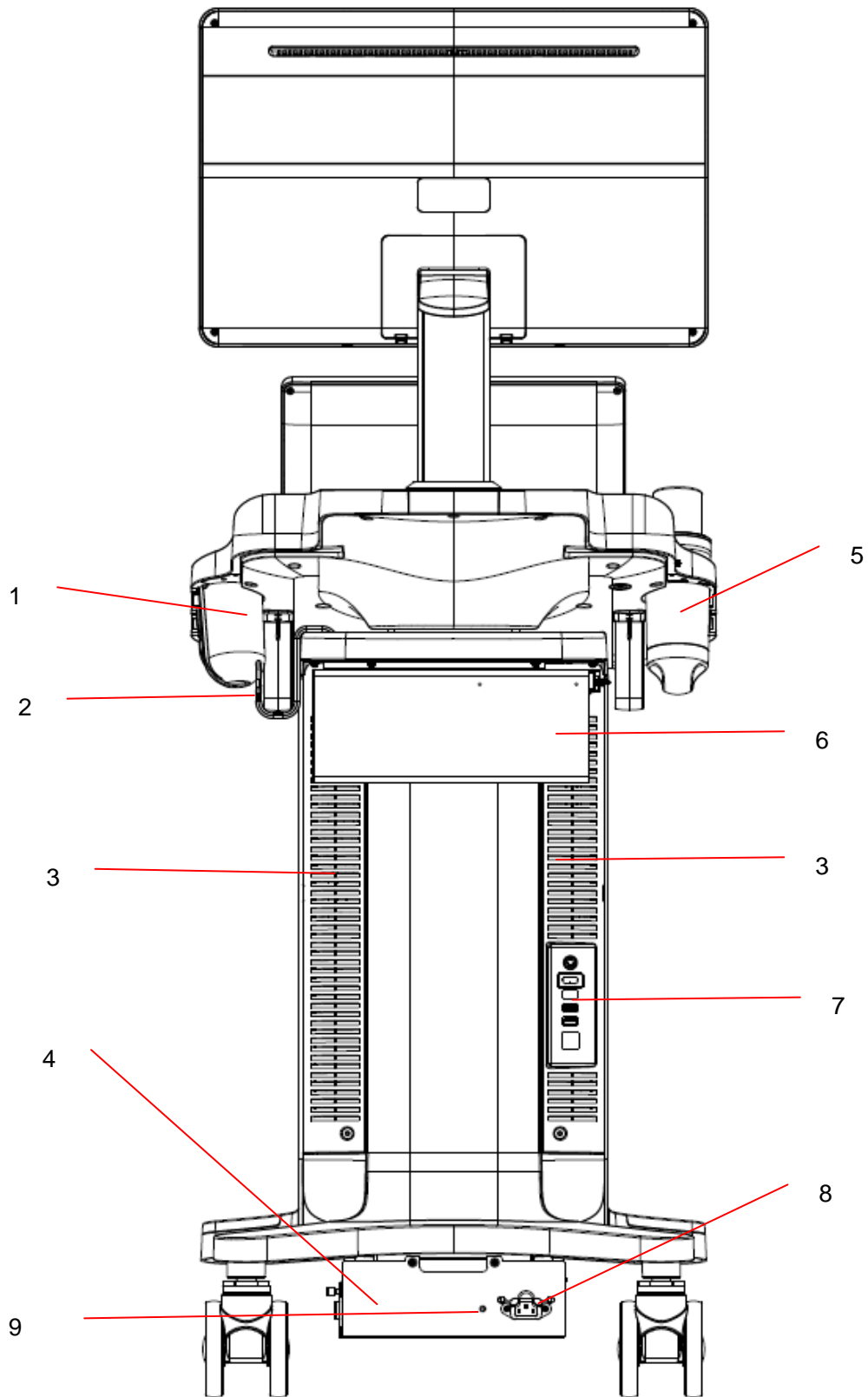


Figure 3-3 Rear View

No.	Description	No.	Description
1	Endo-cavity Transducer Holder	2	Cable Holder
3	System Vents	4	Power Unit/Battery Compartment
5	Coupling Gel Holder/ Gel Warmer(optional)	6	Video Printer/DVD Drive Holder(Optional)
7	I/O Ports	8	AC Power Socket
9	Equipotential Terminal		

Table 3-4 Rear View Description

CAUTION

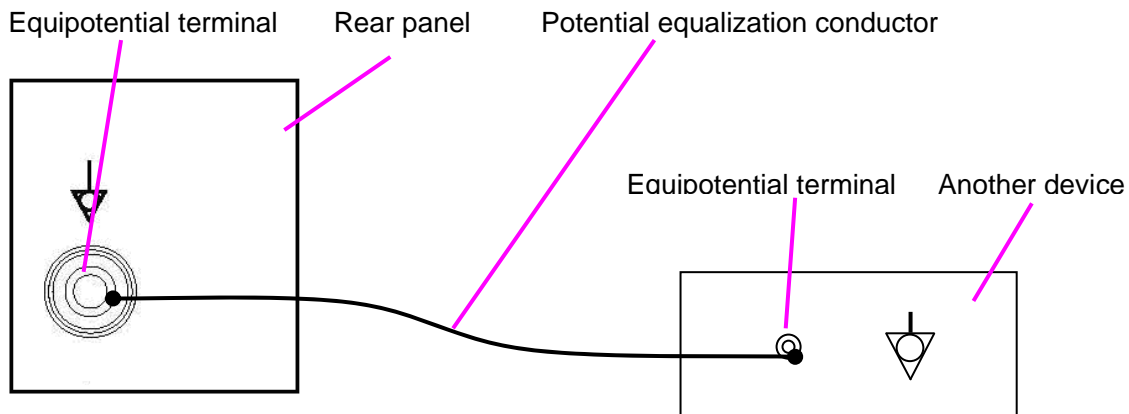
1. To facilitate the disconnection from power supply, please do not cover the AC power socket with any object.
2. Ensure system vents are clear and unobstructed.

Note:

Video printer(SONY UP-X898MD) and DVD Drive (LITEON eBAU108) can be mounted to the ultrasound system by attaching to the back handle (as shown in figure 3-3) with the use of an optional component for holding the video printer and DVD drive.

Equipotential Connection

The equipotential terminal is used for balancing the protective earth potentials between the ultrasound system and other electrical devices. Perform the equipotential connection as the following illustration.



WARNING

1. When you connect another device to the ultrasound system, a potential equalization conductor should be used to connect each of the equipotential terminals. Otherwise, electric shock may result.
2. Any device connected to the ultrasound system must meet the requirements of the applicable IEC/EN60601 series safety standards, and/or the system configuration must meet the requirements of the IEC/EN60601-1.

I/O Ports on the Rear Panel:

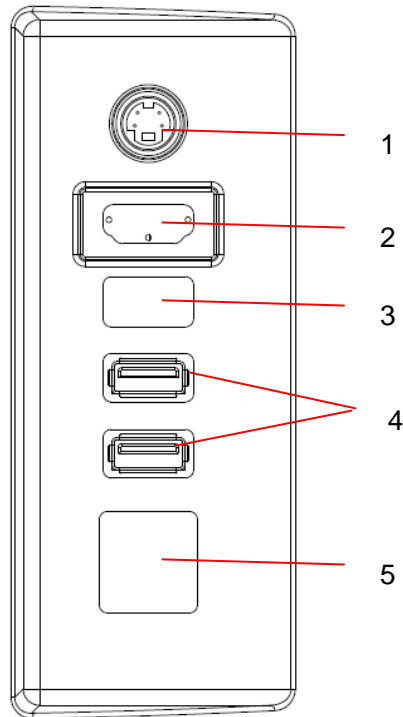


Figure 3-4 I/O ports

No.	Description	No.	Description
1	S-Video output port	2	HDMI port
3	USB 3.0 port	4	USB 2.0 port
5	Network Port		

Table 3-5 I/O Ports

3.2.2. Control Panel

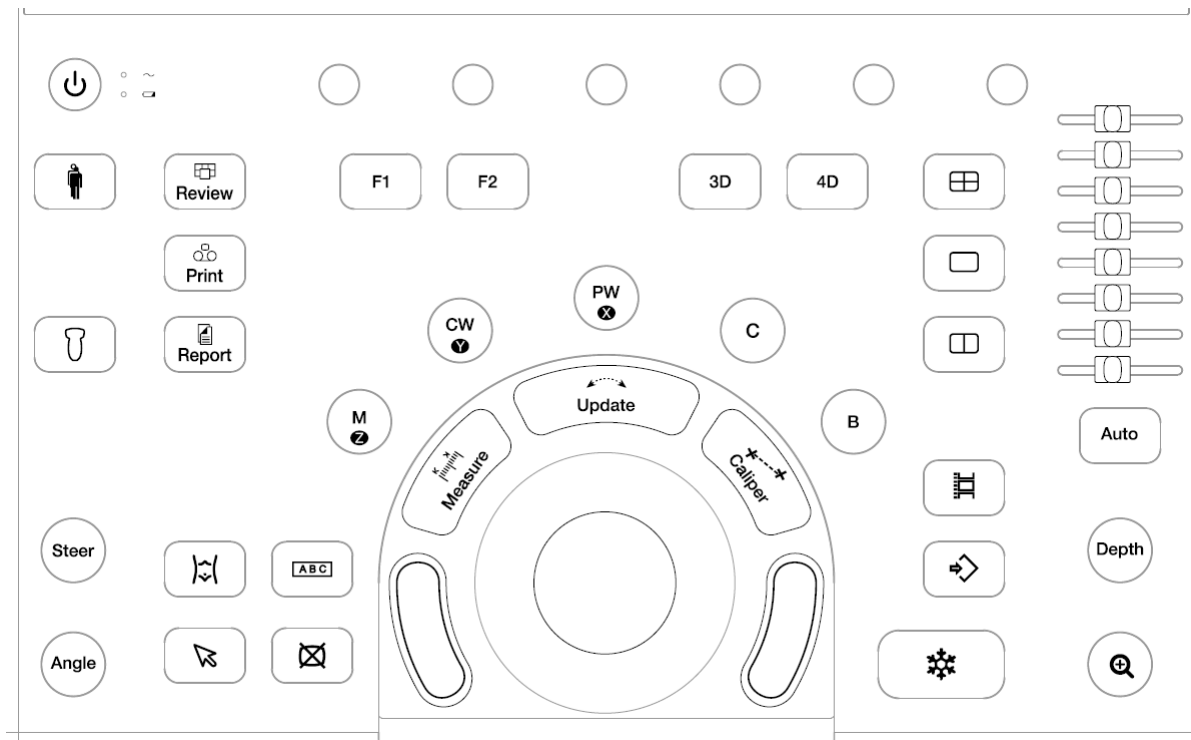










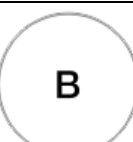
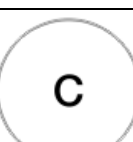





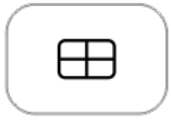
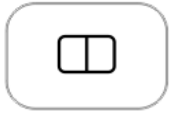



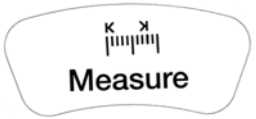
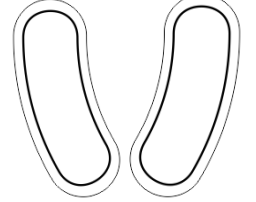




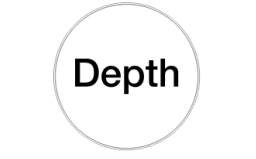

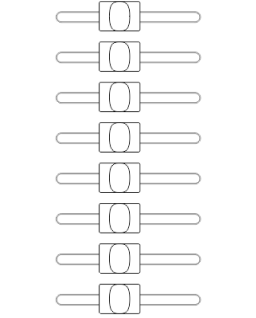


Figure 3-5 Control Panel

No.	Key	Name	Description
1.		Power Switch	Press to power on/off the system.
2.		AC power supply indicator	It illuminates in green when the system is connected to AC power supply. It is off when the system is disconnected from the AC power supply.
3.		Battery indicator	It illuminates in green when the batteries are charging. It is off when the batteries are not installed, the batteries are fully charged or the system is powered on by the batteries.
4.		Patient	Invokes the Patient Information Screen typically used to start/end exams or to modify patient information during an exam.
5.		Transducer	Press to switch transducer or exam presets.
6.		Review	Press to enter exam database or image review mode. See section 9.2 for details.

7.		Print	Press to print images via the connected video printer.
8.		Report	Press to display the report page.
9.		F1	User-defined button. See section 11.1.1 for configuring the user-defined button.
10.		F2	
11.		Steer	The Steer knob control is only available for linear transducers. It can steer B-mode image, Color ROI, PW sample line, etc. Specific operations thereof are described throughout the user manual.
12.		Angle	Adjusts the angle of comment, body marks, etc. Specific operations thereof are described throughout the user manual.
13.		Body Mark	Enters or exits the Body Mark function.
14.		Comment	Enters or exits the Comment function.
15.		Cursor	Press to hide or display the mouse cursor.
16.		Clear	Press to clear all the measurements, calculations, comments, and body marks displayed on the current image.
17.		B	Press to return to B-mode imaging from any other imaging mode and rotate to adjust the gain in B Mode.
18.		Color	Press to enter or exit Color Mode and rotate to adjust the gain in Color Mode.

19.		PW	<p>Press to get the sample line. Use the trackball to adjust the position of the sample line. Press <Update> key to display the Doppler strip. Rotate this knob to adjust the gain in PW Mode.</p> <p>In 3D/4D mode, rotating it can rotate the image by the X-axis of the activated window.</p>
20.		CW	<p>Press to get the sample line. Use the trackball to adjust the position of the sample line. Press <Update> key to display the Doppler strip.</p> <p>This knob is only available when the current active transducer is a phased transducer .</p> <p>In 3D/4D mode, rotating it can rotate the image by the Y-axis of the activated window.</p>
21.		M	<p>Press to enter or exit M Mode and rotate to adjust the gain in M Mode. Use the trackball to adjust the M sample line.</p> <p>In 3D/4D mode, rotating it can rotate the image by the Z-axis of the activated window.</p>
22.		3D	<p>Press to enter or exit 3D Mode. It is only available when the current active transducer is a wobble transducer.</p>
23.		4D	<p>Press to enter or exit 4D Mode. It is only available when the current active transducer is a wobble transducer.</p>
24.		Quad	<p>Enters quad split screen. Each single press on it toggles between four image windows.</p>
25.		Dual	<p>Enters dual split screen. Each single press on it toggles between two image windows.</p>
26.		Single	<p>Press to display the currently active side of Dual image as a single image.</p>
27.		Update	<p>In measurement, pressing <Update> switches the active side of calipers. See section 8 for details.</p> <p>In Pre-Doppler mode, pressing <Update> invokes Spectral Doppler mode. When Spectral Doppler strip is displayed, pressing <Update> allows switching between live acquisition of the Doppler strip or the reference image.</p>

28.		Caliper	Invokes generic measurements. See section 8.1 for details.
29.		Measure	Invokes application measurements. See section 8.2 for details.
30.		Trackball Keys	Two trackball keys provide a wide variety of functions depending on the system state (e.g., selects a start or end point of a measurement, selects menu items on the screen, etc). For the convenience of introduction, we call them <Set> throughout this user manual.
31.		Trackball	Move the trackball to change the cursor position, adjust M mark position in M mode, adjust sample line position in PW mode, etc.
32.		Store Clip	Press to store clips.
33.		Store Image	Press to store static images.
34.		Freeze	Press to switch between the frozen and real-time states.
35.		Depth	Rotate to adjust the depth of the image displayed. Rotate counterclockwise to decrease the depth and rotate clockwise to increase.
36.		Zoom	Rotate to use Pan Zoom function, and press to use Spot Zoom function. See section 7.4 for details.
37.		TGC	<p>The Time Gain Compensation control (TGC) adjusts the gain of the image at different depths. Each slider can be adjusted separately.</p> <p>Glide the slide controls to adjust the TGC. Glide the upper segments to adjust the near field gain, and the lower segments to adjust the far field gain; glide rightward to increase TGC, and glide leftward to decrease.</p>



38.		Auto	<p>In B mode, the Auto push button automatically updates the Overall Gain and TGC.</p> <p>In PW mode, the Auto push button automatically updates the PW gain, DR, baseline and scale.</p> <p>Each single press of the button renews the automatic optimization. Whether Gain, DR or Scale/Baseline is optimized when pressing Auto button in PW mode can be configured in Set-up. See <i>section 11.1.7</i> for detail.</p>
39.		Touch screen paddle Knob(Six)	Each of these six knobs adjusts the setting value of one corresponding paddle control above it on the touch screen.

Table 3-6 Buttons on Control Panel

3.2.3. Screen Layout



Figure 3-6 Main Screen Display

① Information Field

The top line of this field contains your hospital/institution name. Please see Section 11.1.1 *General Set-up* for information on customization.

The second line of this field contains the patient name, gender, age and ID, as entered through the Patient Information screen.

This field also contains data fields for:

- The currently active transducer
- The currently active preset
- System date and time.

② **Image Field**

The ultrasound image appears in the Image field, under the Information field. The Image field also contains information typically associated with the image, such as depth, TGC, maps, image parameters, MI and TI.






③ **Measurements Display Field**

The left side of the screen displays available generic and application measurement items for current exam preset.

④ **Thumbnail Field**


The right side of the screen displays thumbnail images of all statics and clips captured for currently active exam or when in Review. In frozen or review status, moving the cursor onto a thumbnail image can quickly preview it in the image area.

This field also contains several shortcut keys for selecting, viewing, deleting, exporting images. See the below for details:

No.	Shortcut Keys		Description
1		Select All	Selects all the displayed static images and clips.
2		Delete	Deletes the selected static images and clips.
3		Export	Exports the selected static images and clips to removable storage devices.
4		Next/Previous Images	Shows next/previous images when more than one page of images are displayed.
			



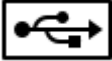




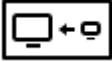


⑤ **User Feedback Field**

The user feedback field is displayed below image field and above status bar. This field displays:

- Virtual trackball and trackball keys.
- Cine bar when the system is frozen.
- An "Exit" icon . Only displayed in review mode. Clicking on this icon will exit the review mode.
- The active function of user-defined key F1 and F2.

⑥ **Status Bar**

The bottom of the screen is used to display icons that provide system status. These include:

No.	Icons		Description
1	Utility icon		Provides access to system setup, screen adjust, connectivity, maintenance, etc.
2	Image Store icon		Displays the number of static images and clips stored in the current exam.
3	USB icon		USB disk available.
4	Printer icon		Printer available. Symbol is in green when printing in progress.
5	Wi-Fi icon		Wi-Fi function is enabled, but no WI-FI network is connected. No WI-FI icon will be displayed when Wi-Fi function is disabled in Connectivity setup.
			Wi-Fi network is connected. Clicking on this icon shows a list of available Wi-Fi networks. Selecting an available network displays a dialog box for entering password. Clicking on the "WiFi: Turn off" button above the list will disconnect the currently connected WI-FI network.
			Wi-Fi network is disconnected. Clicking on this icon shows a "WiFi: Turn on" button. Clicking on this button shows a list of available Wi-Fi networks. Selecting an available network displays a dialog box for entering password.
6	Network Transfer Status icon		The network transfer status icon shows the transfer statuses of the DICOM network. <ul style="list-style-type: none"> • Outline in grey color: At least one DICOM network is configured for file transfer. • Outline in green color: Data exchange with a DICOM Server. • Outline in red color: No DICOM network is configured for file transfer or file transfer failed. Clicking on this icon displays a queue of exam or image transfers and as well as the transfer status of each exam or image including refused, pending, active, succeeded, failed, etc. All the transfer tasks are allowed to re-transfer manually.
7	Hard Drive icon		Hard drive available.
			Hard drive data exchange, symbol in green.

			Hard drive 95% full, symbol in red.
			Hard drive 95% full with data exchange, symbol in red.
8	Battery icon		Battery fully charged, symbol in green.
			Battery more than 80% charged.
			Battery 60%-80% charged.
			Battery 40%-60% charged.
			Battery low, symbol in red.
			Battery removed.
			Battery charging.
9	DVD icon		Symbol in grey: DVD device is connected. Symbol in green: DVD device is connected, disc is inserted and data transmission is available.

3.2.4. Touch Screen

The Touch Screen contains controls that vary depending on the active imaging mode or function. There are several types of controls used by the touch screen, as illustrated below:



Figure 3-7 Touch screen of the System

- A. **Tabs:** Each imaging mode that is active has a tab at the top of the touch screen. Usually, the imaging mode that was most recently activated is the top tab and has priority. Pressing on any other tab will bring it to the top and provide access to the controls available for that imaging mode.
- B. **Paddle:** Pressing on the top or bottom of a paddle changes the control setting by one value. Pressing anywhere on the control and swiping across it will continuously change the value. Each touch screen page displays at most six paddles. Below each paddle there is a knob on the console used to change its setting.
- C. **Push button:** This can either be an on/off control (like “Colorize”) or a one-shot control that immediately performs an action (like “-60/0/60” in PW mode).
- D. **Radio Buttons:** A collection of buttons where only one is active at any time. Activating one will de-activate all others.
- E. **Pages:** When a tab has multiple pages of controls, each page is represented by a dot at the top of the page. The current page is indicated by a filled-in dot. You can move between pages by dragging your finger horizontally across the dots. These dots do not appear when there is only one page in the current tab.
- F. **Function Shortcut Key:** The left side of the touch screen displays five shortcut keys for accessing different imaging modes or functions. The function of shortcut key 1 to 6 can be configured on System Setup page. See section 11.1.1 for details.

3.2.5. Trackball

The trackball operation is easy and convenient. It can achieve the following functions:

- ◆ Move the measurement cursor during measurement.
- ◆ Move the comment cursor in the comment status.
- ◆ Move the M Mark in the B+M mode.
- ◆ Move the scan area of Color mode, increase or decrease the size of scan area of Color mode.
- ◆ Move the sample line and adjust the size of sample gate in the PW/CW mode.
- ◆ Playback the cine in frozen status.
- ◆ Move the zoomed window in the zoom status.

NOTE:

1. Please be gentle when running the trackball.
2. Please keep the surface of trackball clean.

3.3 System Preparation

3.3.1. Battery Use

The system may come with two lithium-ion batteries depending on your order. The fully charged batteries together can run the system for approximately 1.5 hours, depending on use. The batteries are automatically charged when the system is plugged in.

CAUTION

1. If the system will remain unused for more than one week, charge the battery to at least 75% capacity, take the battery out and store the system and battery separately.
2. During long term storage, the battery should be charged at least once every 6 months to ensure battery capacity is more than 75%.
3. Only use Edan supplied battery.
4. Two batteries should be used together to power the system on.

To install the battery:

1. Turn off and unplug the system.
2. Find the battery compartment, located at the lower right side of the system(see figure 3-1) .
3. Unscrew the two screws on the battery door, and open the battery compartment.



4. Move the battery holder (see the figure below) up or down, and put two batteries inside respectively. The side with labeling should face down when putting the battery in.





5. To fix the battery, move the battery holder to the middle position (see the figure below).



6. Close the battery door and secure it.

WARNING

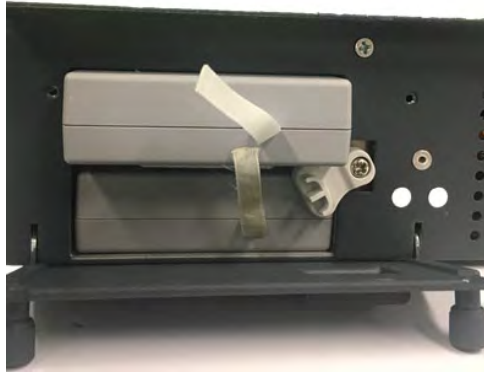
1. When the battery capacity is $\leq 20\%$, the battery status icon turns red.
2. When the battery capacity is $\leq 10\%$, the system displays a prompt "Low Battery. The system will shutdown in 3 mins. Please plug in the power supply immediately."

To remove the battery:

1. Turn off and unplug the system.
2. Find the battery compartment, located at the lower right side of the system(see figure 3-1) .
3. Unscrew the two screws on the battery door, and open the battery compartment.



4. Move the battery holder (see the figure below) up or down, and remove two batteries respectively.



5. Close the battery door and secure it.

3.3.2. AC Power Use

When using AC power, position the system so that it is easy to disconnect it from AC power supply.

To connect AC power:

1. Connect the AC power cord to the power socket on the system(see figure 3-3).
2. Connect the AC power cord to a hospital-grade power outlet.
3. Press the Power button on the control panel to start the system.

WARNING

1. Make sure the AC power supply complies with the following specifications: 100V-240V~, 50Hz/60Hz.
 2. Only use a hospital grade, grounded, power outlet and plug. Do not use with an ungrounded outlet.
 3. Only use Edan supplied power cord.
-

3.3.3. Transducer Connection

To connect a transducer:

1. Align the connector with the transducer port and carefully push into place.
2. Toggle the locking handle to the right position.
3. Do not allow the transducer head to hang free. Impact to the transducer head could result in irreparable damage.

To disconnect a transducer:

1. Toggle the locking handle to the left position to unlock the transducer connector.
2. Firmly grasp the transducer connector and carefully remove it from the system port.
3. Store transducer in its protective carrying case prior to transport.

CAUTION

1. Do not touch the pin of transducer connector.
 2. Broken or bent pin will affect the image quality. Please do not the transducer with broken or bent pin.
 3. Only disconnect a transducer when the system is shutdown or is frozen.
-

3.3.4. Powering on/ off

Please review and follow the steps described in the Section *13.1.Daily Checklist* prior to powering on the system.

To power on

1. Connect the system to a hospital grade power supply, or use the battery as the power supply.
2. Press the Power on/off key on the top left of the control panel.

To Login

If Password Protection is enabled (see section 11.1.7), the system displays a Login dialog when booting up the system. Type in or select user name from the User Name drop-down list, then enter password and click **Login**. At the first system powering on after you received the system, a dialog will display for you to set the login password of the pre-defined administrator user.

For emergency use, click on **Emergency** to log on directly without entering user name and password.

NOTE:

1. It is not suggested to use Emergency login under non-Emergency situation. Please login the system with your account or switch to your account through the Switch User function (See "To Switch Users" below) prior to imaging scanning.
2. Ensure the privacy of patient information and data created through Emergency login. It is suggested to remove the patient exam data from the ultrasound system after Emergency scanning for protecting patient data from being accessed by unauthorized users.

To Switch Users

If Password Protection is enabled, switching users is allowed without restarting the system.

1. Press Power on/off key, and the system will display a confirmation dialog box.
2. Select **User** from the confirmation dialog box. A login information dialog box will be displayed providing access to change user.
3. Select another user from the User Name drop-down list and then enter password to login.

To power off:

1. Press the Power on/off key on the top left of control panel and the system displays a confirmation dialog box.
2. Select "Shut Down" from the confirmation dialog box.

If the system is unresponsive, a long press of the Power on/off key will shut down the system directly.

NOTE:

1. Turn off and unplug the device after use.
2. Please unplug the AC plug from the power socket and disconnect the battery prior to storage.

Sleep mode

The system will enter a sleep mode that maintains exam information while using minimal power. There are three events that can invoke sleep mode:

- No user input for a configurable amount of time. Please see System Set-up to configure this time.

- Pressing the **Sleep** button on the confirmation dialog box when powering off.

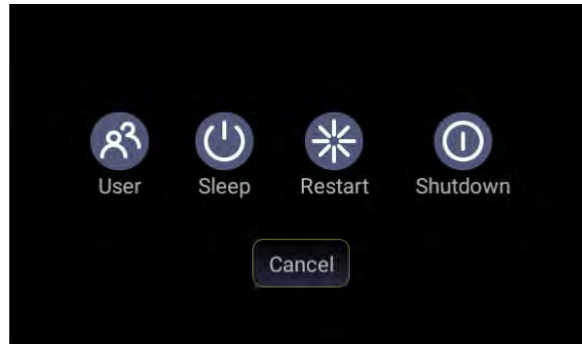


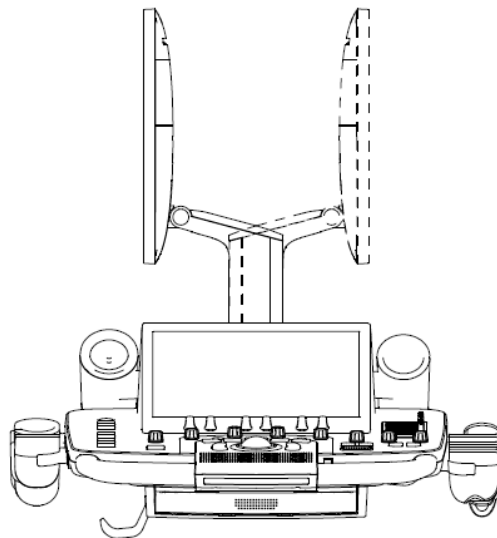
Figure 3-8 Confirmation Dialog Box When Power off

Pressing any key on the control panel or moving the trackball will exit the sleep mode.

3.4 Monitor Position Adjustment

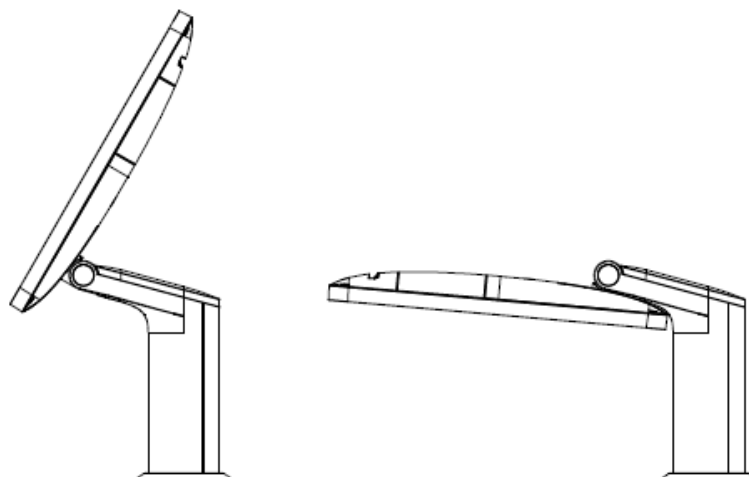
◆ *Rotating the monitor*

The monitor can be rotated leftwards or rightwards along with the support arm, as the figure shown below.



◆ *Tilting the monitor*

The monitor can be tilted backwards or forwards from the vertical position, as the figure shown below.



CAUTION

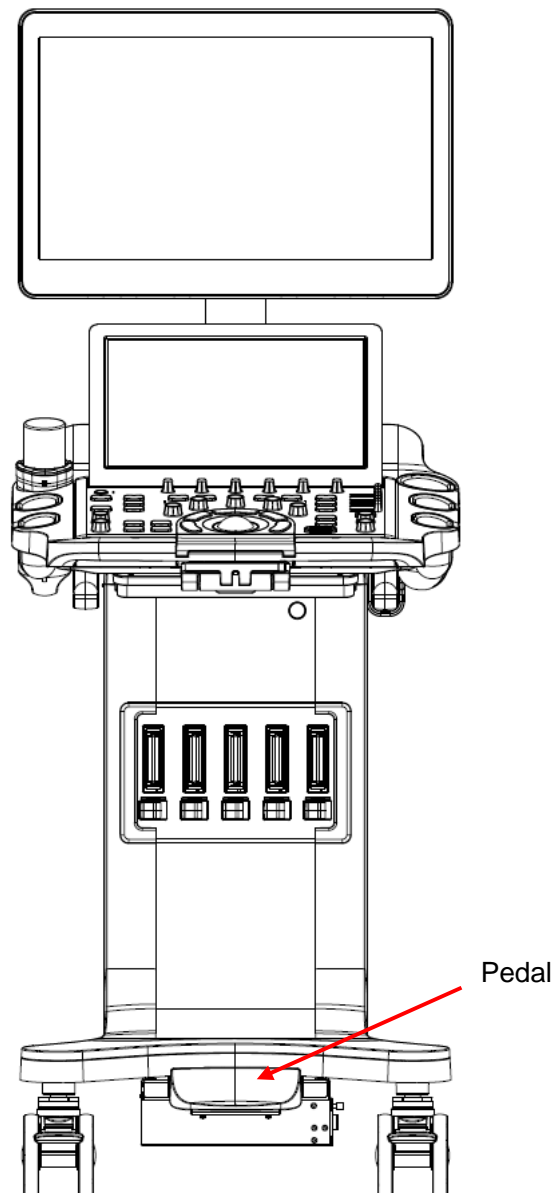
1. Ensure enough spaces are available before rotating the monitor.
2. Please mind your hands when adjusting the position of the monitor.

3.5 Control Panel Height Adjustment

To move the control panel up, hold the handle of the trolley and lift it with slight force while you are stepping on the pedal.

To move the control panel down, hold the handle of the trolley and push it down with slight force while you are stepping on the pedal.

When the trolley reaches the desired height, stop stepping on the pedal.



4 Exam Operation

4.1 How to Start an Exam

1. Press the **<Patient>** key and enter patient information, or select a scheduled patient from the modality worklist.

If there is no previous exam, pressing the **<Patient>** key will bring you directly to the Patient Information Page (see figure 4-3 below).

If a previous exam is still active you will see the following dialog:

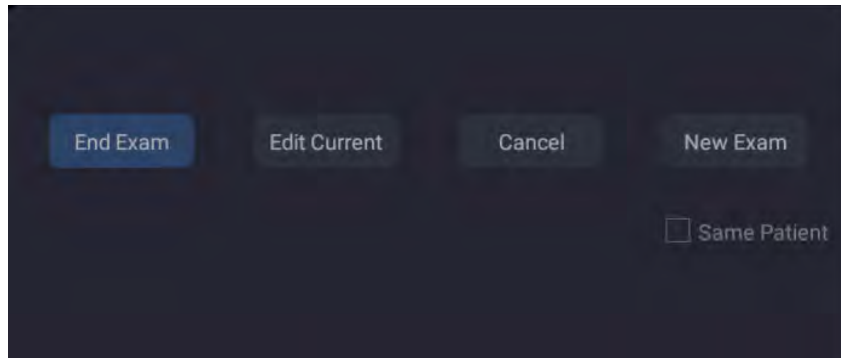


Figure 4-1 Exam Confirmation Dialog

The following options are available:

- **End Exam:** select this to end the current exam and return to live imaging to start a new exam.
 - **Edit Current.** This lets you edit the Patient Information for the current exam. It does not start a new exam.
 - **New Exam:** Select this to start a new exam.
If **Same Patient** is checked, selecting **New Exam** will end the previous exam and create a new exam for the same patient. The main screen will display the Patient Information Page with the previously entered patient information except for the exam accession number.
If **Same Patient** is unchecked, selecting **New Exam**, a blank Patient Information Page will be displayed for entering patient information for a new patient.
Tick the check box of **Same Patient** when operating multiple exams for same patient.
 - **Cancel:** Exits the dialog without starting or ending an exam.
2. Press **OK** on the touch screen or press the **<Patient>** key again to start scanning.
 3. To change transducer or exam preset, press the **<Transducer>** key, and then the **Transducer** touch screen provides you choices of available transducers and exam presets, as the figure below.

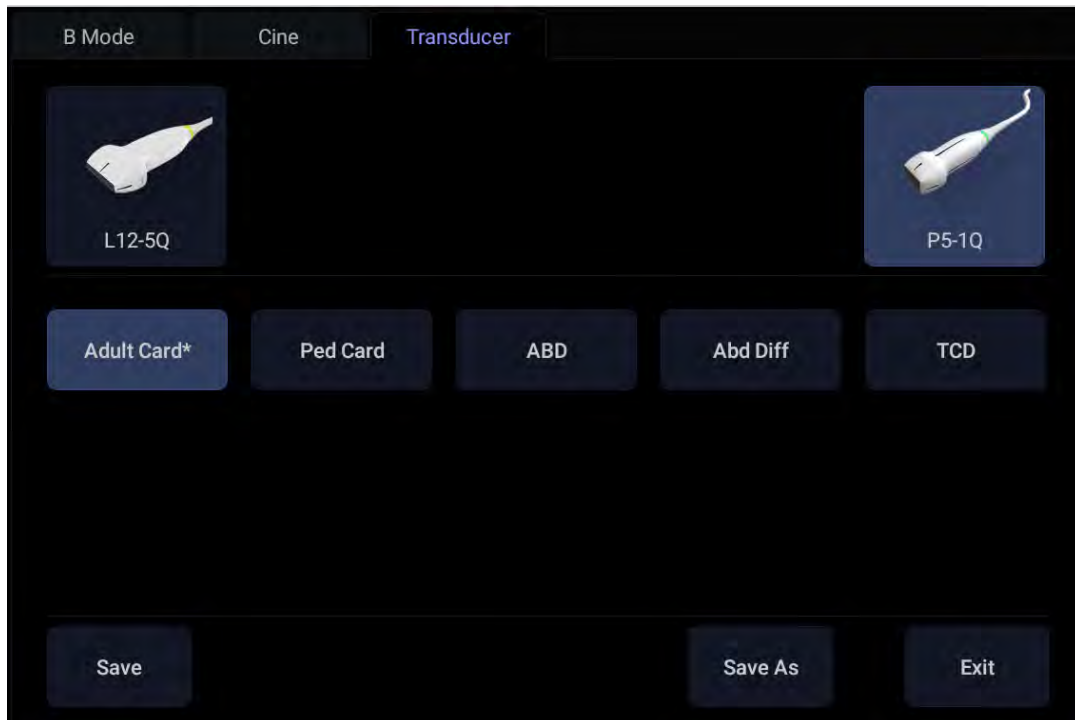


Figure 4-2 Example of Transducer Touch Screen

4.2 How to End an Exam

There are two ways to end an exam:

- Pressing the **<Patient>** key, as described above, and then selecting **New Exam**. This both ends the exam and displays the Patient Information Page for the next exam.
- Pressing the **<Patient>** key, as described above, and then selecting **End Exam**. This brings up a dialog to confirm you want to end the exam, but does not invoke the Patient Information Page for the next exam.

4.3 How to Restart an Exam

1. Select an exam from the Exam Database within the time limit selected in **Patient** Set-up menu. For the setting of time limit, refer to section *11.1.2 Patient Set-up*.
2. Press **Restart** on the touch screen to continue/edit the exam that was performed on the selected patient. You can also modify the patient information by pressing **<Patient>-->Edit Current**.

4.4 The Patient Information Page

The Patient Information Page is used to enter or modify patient demographic data. The following figure is an example:

Figure 4-3 Patient Information Page(OB Exam)

The top three lines are for entering the patient last name, first name, ID, exam accession number, and DOB (Date-of-Birth) or age. If date of birth is entered, the age is automatically calculated.

Note:

By default, the patient name has two fields: family name and given name. It can be configured to be one field in the Patient Setup screen (See section 11.1.2 for detail).

The next line displays tabs of multiple exam presets, and the associated patient information fields are displayed below this line. The patient information needed to fill in changes with different exam presets.

All the possible patient information fields you may need to fill in are listed below:

- Gender: Select the patient's gender: "M" (Male), "F" (Female), "O" (Other), or "<blank>".
- LMP: Last Menstrual Period (yyyy/mm/dd or mm/dd/yyyy), If LMP is entered then GA and EDD are calculated. An LMP more than 300 days ago is considered invalid.
- BBT: Enter the ovulation day when the BBT(Basal Body Temperature) reaches the peak. If BBT is entered then GA and EDD are calculated. A BBT more than 300 days ago is considered invalid.

Note: LMP and BBT can be switched to enter the value according to your needs.

- GA: Gestational Age (xxWyD), it is autocalculated when LMP is entered (only in OB Exam). A GA of more than 42W6D is considered invalid and not displayed.
- EDD: Estimated Date of Delivery (yyyy/mm/dd or mm/dd/yyyy).EDD is autocalculated when LMP is entered.
- Fetus: Enter 1 up to 4 for multiple gestations.

- G/P/A: G stands for Gravida, P stands for Para and A stands for Aborta. Enter values for each in the fields separated by slashes.
- Study Description: enter the study description.
- Height: Enter the patient's height. The units can be set in the Patient section of Setup.
- Weight: Enter the patient's weight. The units can be set in the Patient section of Setup.
- BSA: Body Surface Area, it is auto-calculated and displayed when Height/Weight is entered.
- HR: Enter the Heart Rate.
- BP: Enter the Blood Pressure.
- PSA: Prostate Specific Antigen.
- PPSA Coefficient: Predicted Prostate Specific Antigen.
- Ref. Physician: Enter the name of the Ref.Physician.
- Dx. Physician: Enter the name of the Dx.Physician.
- Operator: Enter the name of the person performing the exam..
- CPT code: Current Procedural Terminology code.
- Comment: Enter any additional comments.

While the Patient Information Page is displayed the following buttons are displayed on the touch screen and Patient Information Page:

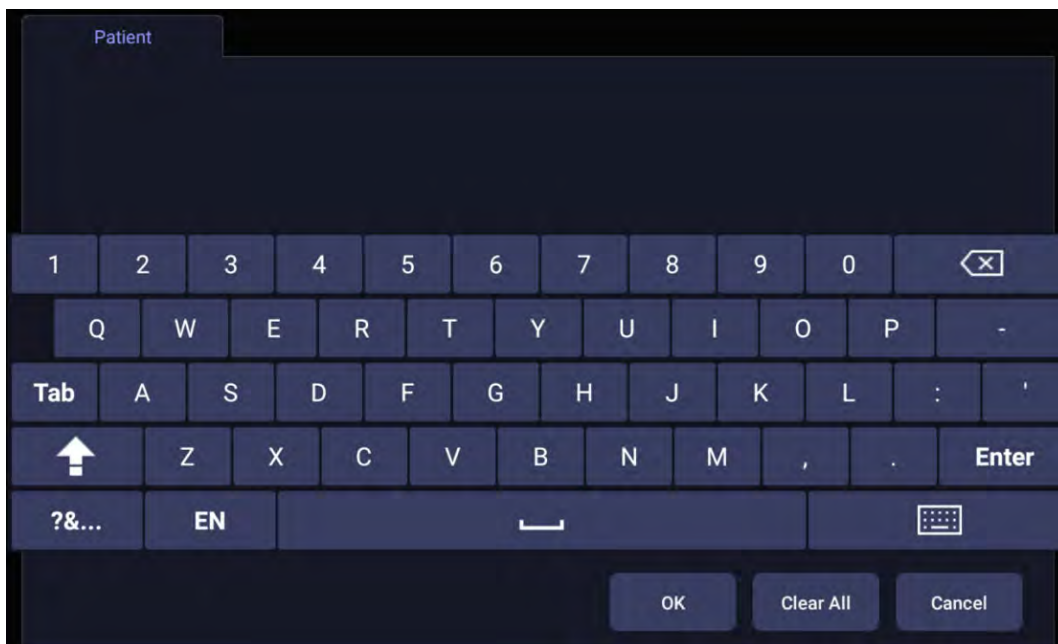


Figure 4-4 Patient Information Touch Screen

Press **OK** to exit the Patient information Page and save the patient information.

Press **Cancel** to exit the Patient Information Page without storing any of the entered data.

Press **Clear All** to clear all of the demographic fields except for name and ID.

4.5 Modality Worklist

Modality worklist provides a list of scheduled patients derived from a DICOM server. It is available only when a DICOM server is configured and worklist is enabled.

The worklist is shown to the left of the Patient Information Page, as shown below.

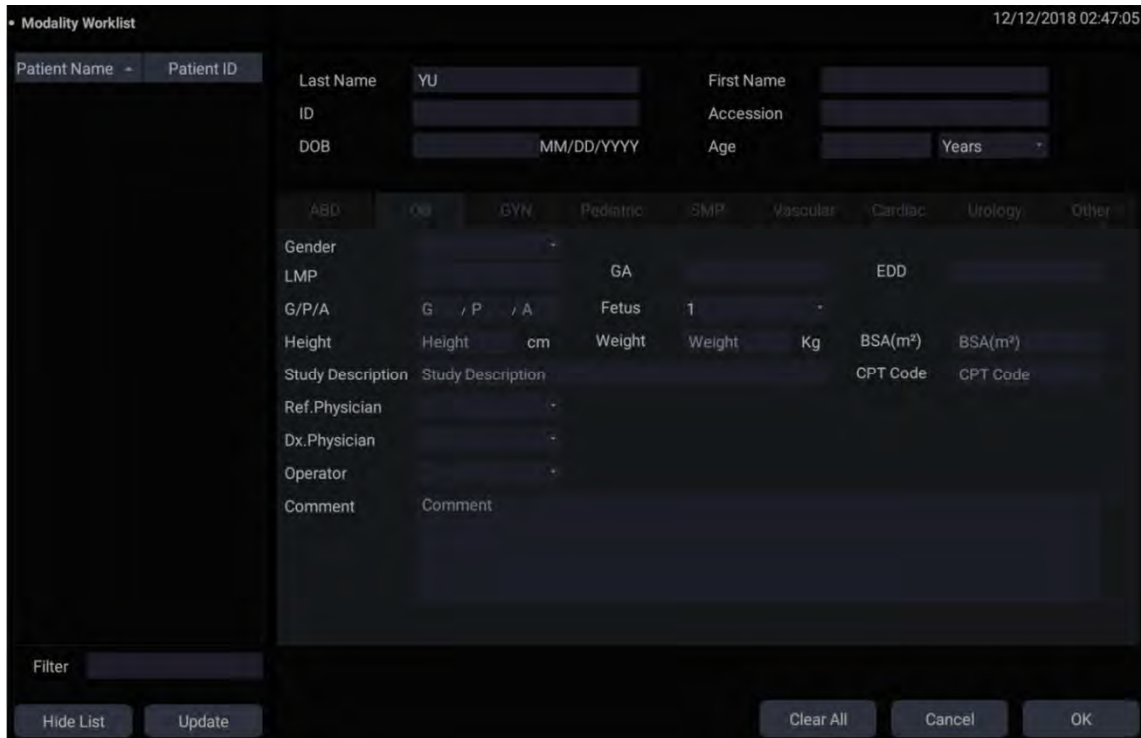


Figure 4-5 Modality Worklist Display

The worklist is displayed on the left side of the Patient Information Page in two columns labeled patient name and patient ID. Clicking on the header of each column will sort the list for the corresponding column.

The worklist shows all scheduled ultrasound exams within the date-range specified in the DICOM connectivity setup screen (See 11.2.2). Typing any text in the **Filter** field will filter the list to exams that contain the entered text.

Update: Press to query the patient data and update the list manually.

Hide List: Press to hide the list with only a **Show List** button displayed. Press the **Show List** button to display the list and other buttons.

Select one patient from the list and the detailed patient information is entered into the associated fields on the patient information page, with the option to edit or complete. Then press **OK** on the touch screen to start an exam.

5 Imaging

5.1 B-mode

5.1.1. Using B-mode

1. Press on the console to enter B mode.
2. Perform the image scanning.
3. Adjust Image parameters to optimize the image.

5.1.2. B-mode Image Optimization

The following touch controls can be used to optimize the B-mode image.

Name	Control	Description
Dynamic Range		The Dynamic Range, or log compression, adjusts how echo intensities are converted to brightness. A high dynamic range will display more shades of gray, while a low dynamic range will display fewer shades of gray and a more contrasty image.
eSRI		eSRI is Speckle Reduction Imaging. There are 4 levels: Off, Low, Med. and High. High level provides more aggressive speckle reduction.
Persistence		Persistence averages frames together to reduce random noise. There are 4 options: Off, Low, Med., and High. The persistence level corresponds to the number of frames averaged. The frame rate is unchanged.
Frequency		Frequency allows selection of the fundamental or harmonic frequencies used for imaging. The Harmonic option must be invoked to access the harmonic frequencies. Frequency selection is available during live imaging.
Harmonic		The Harmonic control invokes and exits harmonic imaging. While in harmonic imaging the control is highlighted and an 'H' is displayed in the B-mode frequency field. Depending on the transducer, there may be multiple harmonic frequencies.
Spatial Compounding		Spatial Compounding combines images derived from multiple angles to reduce speckle, reduce shadow artifacts, and enhance contrast resolution. Spatial compounding is an on/off control.

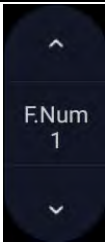
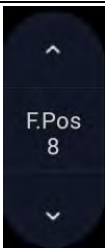
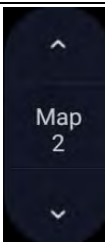
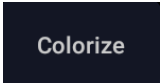
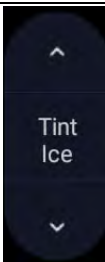

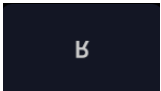
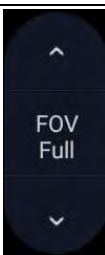

Focus Number		Focus Number adjusts the number of foci is displayed. As the number of foci increases, image uniformity across depth will increase, but the frame rate will decrease.
Focus Position		Focus Position adjusts the depth of the focus or foci. Upward presses move the focus shallower, regardless of the U/D invert status of the image.
Gray Map		Gray Map adjusts the postprocessing map used on the B-mode image. In general, higher map numbers correspond to more contrast in the image.
Colorize		The Colorize control adds a color tint to the B-mode image.
Tint		The Tint control changes the color tint being used. If Colorize had been off, changing the Color map control will automatically activate it.
Left/Right		The Left/Right invert control is indicated by a backward R and is used to toggle the left/right orientation of the image. The Edan E orientation marker at the top of the image switches with the left/right invert to match the orientation marker on the transducer.
Up/Down		The Up/Down invert control is indicated by an upside-down R and is used to toggle the up/down orientation of the image. The TGC curve is also re-oriented with Invert On, so that the top of the TGC curve corresponds to the top of the image on the screen.
FOV		The Field of View control adjusts the image width. Full, Large, Med. and Small settings are available. As the image becomes narrower, the frame rate increases.
Trapezoid		The Trapezoid control activates the trapezoidal imaging on linear transducers. It is a part of the B-mode function and available in live imaging.

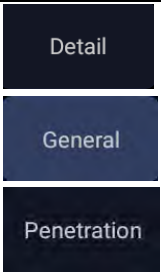
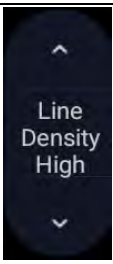
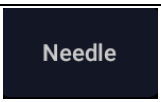
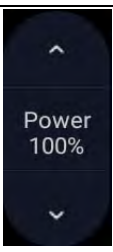
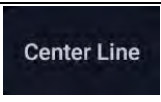

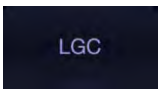

Image Type		B-mode supports presets for Detail, General, and Penetration. See section 10.3.2 for more information.
Line Density		Adjusts the line density to optimize the lateral resolution for the best possible image. The higher the line density, the higher the lateral resolution, but the lower the frame rate.
Needle		Press to invoke the touch screen for Needle Biopsy Guide function. See section 6.4 for more information.
Acoustic power		Adjusts the acoustic output power of the activate transducer and is only available in live imaging. Higher acoustic power numbers correspond to increased sensitivity in the image with improved penetration, but the ALARA principle should be followed in actual clinical situations.
Center Line		Press to activate the Center Line function. Refer to section 6.6 for details.
eLearn		Press to access the instruction guide for basic scanning and for nerve block.
LGC		Lateral Gain Control (LGC) adjusts the gain along the scan line to improve the lateral resolution of the image. Press LGC touch screen key to display 8 gain control sliders. Move the slider downwards to decrease the gain, while move the slider upwards to increase the gain. Each slider can be adjusted separately, or you can drag your finger horizontally to adjust all sliders to a new setting.
3D 4D		Press to activate 3D/4D imaging mode. Refer to section 5.8 <i>3D/4D mode</i> for details.

Table 5-1 B-mode Touch Screen Controls

5.2 Color Mode

5.2.1. Color Mode Variants

The system supports 3 types of Color Doppler imaging:

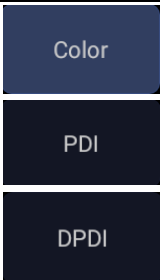
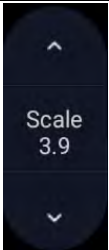
- **Color (Color Doppler):** This is velocity Color Doppler that shows direction and velocity of flow. Different colors represent different velocities and positive flow has different colors than negative flow.
- **PDI (Power Doppler Imaging):** PDI shows the power, or intensity, of the Doppler signal. PDI is typically more sensitive to low levels of flow, but cannot distinguish the velocity or direction of the flow.
- **DPDI (Directional Power Doppler Imaging):** This is similar to PDI in that it shows the power of the Doppler signal instead of the velocity. However, it does map positive flow to different colors than negative flow.

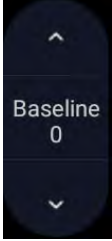
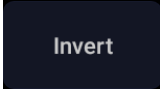
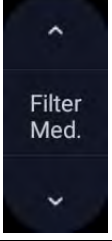
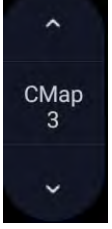
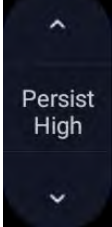
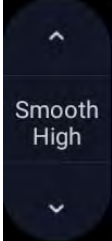
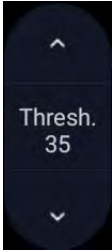
5.2.2. Using Color Mode

1. Perform the image scanning to get a good image in B mode;
2. Press **<C>** to enter B+Color mode and display ROI box;
3. Adjust the size and position of ROI box.
Presses on **<Set>** switch between the status of adjusting the size and position of ROI box. Use trackball to adjust.
4. Press **PDI**, **DPDI** or **Color** mode key on the touch screen to switch Color Doppler modes when necessary;
5. Adjust image parameters to optimize the Color image.

5.2.3. Color Image Optimization

The following touch controls can be used to optimize the Color image.

Name	Control	Description
Color Mode Variation		A set of radio-buttons display the color modes that are available on the current transducer, and let you switch between them. See section 5.2.1 for details.
Scale		Scale adjusts the range of velocities that are displayed. Upward presses increase scale and downward presses decrease it. It is available in Velocity, PDI, and DPDI. It is not available in Freeze/Cine.

<p>Baseline</p>		<p>The Baseline control adjusts the Color baseline. Upward presses move the baseline up on the scale and downward presses move the baseline down. Baseline is not available in PDI mode.</p>
<p>Invert</p>		<p>Normally, signals above the baseline are positive velocities (moving toward the transducer). However, when Invert is pressed then negative velocities are above the baseline. Invert does not affect the baseline position. Invert is not available in PDI mode.</p>
<p>Wall Filter</p>		<p>The Filter control removes excessive noise from movement of vessel walls. Options of Low, Med. and High are available. Higher wall filter level will suppress more strong single of the vessel walls, but low flow signal will be missing.</p>
<p>Map</p>		<p>Adjusts the current map for the active color variation.</p>
<p>Persist</p>		<p>Persistence determines the number of frames that are averaged together for display. Levels of Off, Low, Med. and High are available.</p>
<p>Smooth Filter</p>		<p>The smoothness filter determines the spatial filtering that is applied to the Color image. Higher filter levels create a smoother image. Upward presses increase the filter. Downward presses decrease the filter.</p>
<p>Threshold</p>		<p>When the system receives both B-mode and color signals from a region within the Color ROI box, the Threshold determines whether to display overlapping signals as grayscale or color. In Color mode, higher Threshold values display more color, and lower Threshold values display more grayscale. Upward presses increase threshold. Downward presses decrease threshold.</p>

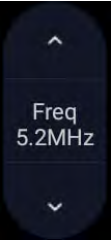
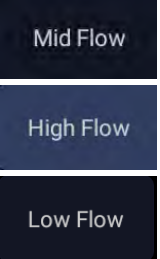
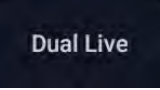
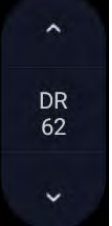
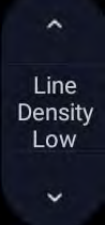
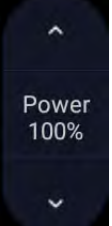
<p>Frequency</p>		<p>Frequency determines the transmit frequency used by color Doppler. Upward presses increase the frequency. Downward presses decrease the frequency.</p>
<p>Image Type</p>		<p>Color Doppler supports image presets for Low Flow, Medium Flow, and High Flow.</p>
<p>Dual Live</p>		<p>To activate split screen with simultaneous live B/Color and live B. The live B image without color and the same live B image with color are simultaneously displayed on each side of the image field. Freezing the image will freeze both sides simultaneously. Cine review will review both sides simultaneously.</p>
<p>Dynamic Range</p>		<p>The Dynamic Range, or log compression, adjusts how echo intensities are converted to brightness. A high dynamic range presents a flatter, less contrasty color display, while a low dynamic range presents a more contrasty color display. Only available in PDI/DPDI mode.</p>
<p>Line Density</p>		<p>Adjusts the line density to optimize the lateral resolution for the best possible image. The higher the line density, the higher the lateral resolution, but the lower the frame rate.</p>
<p>Acoustic power</p>		<p>Adjusts the acoustic output power of the activated transducer. It is only available in live imaging. Higher acoustic power numbers correspond to increased color sensitivity and penetration, but the ALARA principle should be followed in actual clinical situations.</p>

Table 5-2 Color Mode Touch Screen Controls

5.3 PW Mode

5.3.1. Using PW Mode

1. Perform the image scanning to get a good image in B mode or B+Color(DPI/DPDI) mode;
2. Press <PW> on the console to display sample line;
3. Use the trackball, <Angle> knob and other controls to adjust the position of the sample line and the size and angle of the sample gate;

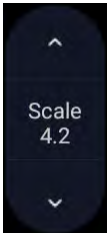
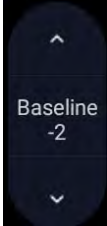
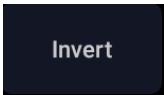

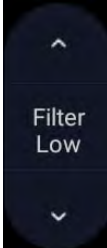
Note:

Pressing <Set> key can switch between the status of adjusting the position of the sample line and adjusting the size of the sample gate.

4. Press <Update> on the console to enter B+PW or B+Color(PDI/DPDI)+PW mode and display Doppler strip.
5. Adjust image parameters to optimize the Doppler strip.
6. When spectrum is displayed, pressing <Update> toggles between acquiring the Doppler strip and acquiring the reference image.

5.3.2. PW Image Optimization

The following touch controls can be used to optimize the PW image.

Name	Control	Description
Scale		Scale adjusts the range of velocities that are displayed. Upward presses increase scale and downward presses decrease scale. Increasing scale when the PW cursor is relatively deep may result in invoking HPRF, if it is configured. See section 5.3.3 for details.
Baseline		The Baseline control adjusts the Doppler baseline. Upward presses move the baseline up on the screen and downward presses move the baseline down.
Invert		Normally, signals above the baseline are positive velocities (moving toward the transducers). However, when Invert is pressed, the negative velocities are displayed above the baseline. Invert does not affect the baseline position.
Quick-Angle		Adjusts the angle correct quickly to one of 60/0/-60.
Filter		The Filter control removes excessive noise from movement of vessel walls. Options of Low, Med. and High are available. Higher wall filter level will suppress more strong single of the vessel walls, but low flow signal will be missing.

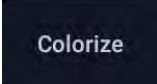
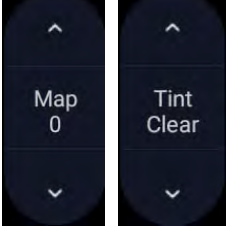
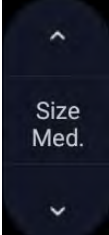
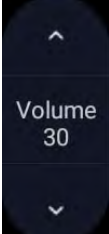
Colorize		Switches between grayscale and colorized (pseudo-color) postprocessing maps.
Gray Map Tint		Adjusts the current postprocessing, either grayscale or tinted.
Dynamic Range		The Dynamic Range, or log compression, adjusts how signal intensities are converted to brightness. A high dynamic range will display more shades of gray, while a low dynamic range will display fewer shades of gray and a more contrasty Doppler display.
Gate Size		Gate adjusts the size of the sample volume gate. Upward presses increase the gate size. Downward presses decrease the gate size.
Sweep Speed		Sweep adjusts the sweep speed of the Doppler strip. Options of Slow, Low, Med., High and Fast are available. Upward presses increase sweep speed. Downward presses decrease sweep speed.
Strip Size		Changes the relative size of the Doppler strip compared to the reference image. Full, Large, Med. and Small are available.
Volume		Volume adjusts the audio volume of the Doppler strip. This can be adjusted in pre-Doppler to set the initial volume upon invoking Doppler acquisition.
Duplex Triplex		This determines if the strip mode and reference image are imaging simultaneously or not. In Duplex mode, either the Doppler strip or the reference image is updated continuously. In Triplex mode, both the Doppler strip and reference image are updated simultaneously.

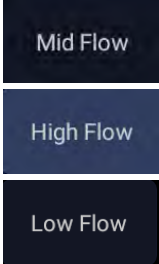
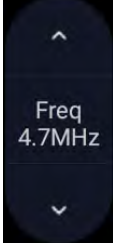
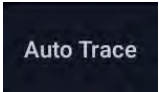
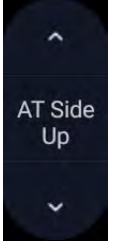
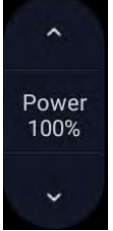
Image Type		Spectral Doppler supports image presets for Low Flow, Medium Flow and High Flow.
Frequency		This determines the Doppler transmit frequency used for imaging.
Auto Trace		Press to activate the Auto Trace function on a real-time or frozen PW Doppler strip. The Auto Trace function automatically traces the spectral Doppler waveform and records several measurements on selected waveforms.
Trace Side		Press one of the three options to specify which side of the Doppler baseline to take measurements from: Up : traces positive portion of waveform (above baseline). Down : traces negative portion of waveform (below baseline). Both : traces waveform on both sides of baseline.
Acoustic Power		Adjusts the acoustic output power of the activated transducer. It is only available in live imaging. Higher acoustic power numbers correspond to increased sensitivity in the Doppler display and improved penetration, but the ALARA principle should be followed in actual clinical situations.

Table 5-3 PW Mode Touch Screen Controls

5.3.3. HPRF

Conventional PW Doppler scales are limited by the Nyquist limit. High Pulse Repetition Frequency (HPRF) allows the system to exceed the Nyquist limit by having multiple Doppler pulses in the body at the same time. In HPRF imaging, multiple Doppler gates are displayed since the multiple Doppler pulses could be giving information from different depths. HPRF is automatically invoked when needed to maintain the requested depth and scale. For example, if the system is at a high scale and you move the cursor deeper, the system may automatically invoke HPRF. This can also happen if the cursor is deep and you increase scale.

If HPRF is active, you will see multiple Doppler gates on the reference image. If you do not want to be in HPRF, decrease the scale or move the primary PW gate to a shallower location until only one gate is displayed.

5.4 CW Mode

5.4.1. Using CW Mode

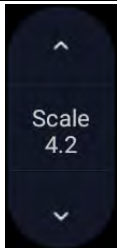
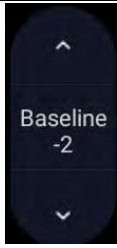
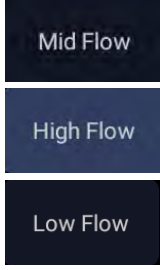
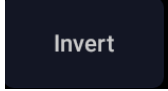

CW mode is only available on phased array transducer.

1. Perform the image scanning to get a good image in B mode or B+Color(DPI/DPDI) mode;
2. Press <CW> on the console to display sample line;
3. Use the trackball, <Angle> knob and other controls to adjust the position of the sample line and the size and angle of the sample gate;
4. Press <Update> on the console to enter B+CW or B+Color(PDI/DPDI)+CW mode and display Doppler strip.
5. Adjust image parameters to optimize the Doppler strip.
6. When spectrum is displayed, pressing <Update> toggles between acquiring the Doppler strip and acquiring the reference image.

In CW mode, pressing on <PW> on the console will switch PW mode directly.

5.4.2. CW Image Optimization

The following touch controls can be used to optimize the CW image.

Name	Control	Description
Scale		Scale adjusts the range of velocities that are displayed. Upward presses increase scale and downward presses decrease it.
Baseline		The Baseline control adjusts the Doppler baseline. Upward presses move the baseline up on the screen and downward presses move the baseline down.
Image Type		Strip Doppler supports image presets for Low Flow, Medium Flow, and High Flow.
Invert		Normally, signals above the baseline are positive velocities (moving toward the transducer). However, when Invert is pressed then negative velocities are above the baseline. Invert does not affect the baseline position.
Quick-Angle		Adjusts the angle correct quickly to one of 60/0/-60.

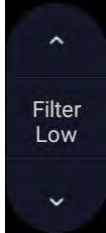
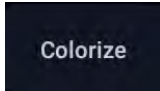
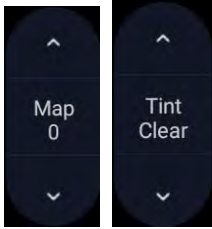
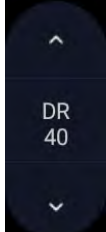
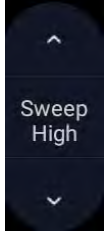
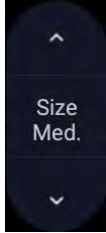
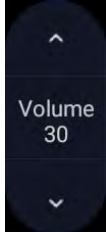
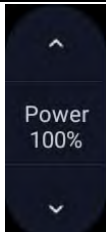
Filter		<p>The Filter control removes excessive noise from movement of vessel walls. Options of Low, Med. and High are available. Higher wall filter level will suppress more strong single of the vessel walls, but low flow signal will be missing.</p>
Colorize		<p>Switches between grayscale and tinted (pseudo-color) postprocessing maps.</p>
Gray Map Tint		<p>Adjusts the current post processing, either grayscale or tinted.</p>
Dynamic Range		<p>The Dynamic Range, or log compression, adjusts how signal intensities are converted to brightness. A high dynamic range will display more shades of gray, while a low dynamic range will display fewer shades of gray and a more contrasty Doppler display.</p>
Sweep Speed		<p>Sweep adjusts the sweep speed of the Doppler strip. Options of Slow, Low, Med., High and Fast are available. Upward presses increase sweep speed. Downward presses decrease sweep speed.</p>
Strip Size		<p>Changes the relative size of the Doppler strip compared to the reference image. Full, Large, Med. and Small are available.</p>
Volume		<p>Volume adjusts the audio volume of the Doppler strip. This can be adjusted in pre-Doppler to set the initial volume upon invoking Doppler acquisition.</p>
Acoustic Power		<p>Adjusts the acoustic output power of the activated transducer. It is only available in live imaging. Higher acoustic power numbers correspond to increased sensitivity in the Doppler display and improved penetration, but the ALARA principle should be followed in actual clinical situations.</p>

Table 5-4 CW Mode Touch Screen Controls

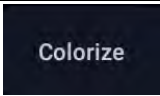
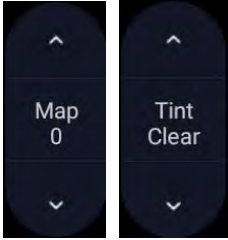
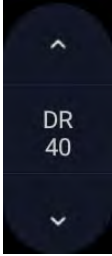
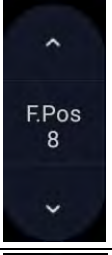
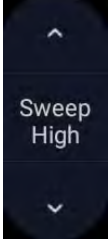
5.5 M-mode

5.5.1. Using M-mode

1. Perform image scanning to get a good image in B mode;
2. Press **<M>** to display M strip and sample line;
3. Move the trackball to adjust the sample line;
4. Adjust image parameters to optimize M strip.

5.5.2. M-mode Image Optimization

The following touch controls can be used to optimize the M-mode image.

Name	Control	Description
Colorize		Switches between grayscale and colorized (pseudo-color) postprocessing maps.
Gray Map Tint		Adjusts the current postprocessing, either grayscale or tinted.
Dynamic Range		The Dynamic Range, or log compression, adjusts how echo intensities are converted to brightness. A high dynamic range will display more shades of gray, while a low dynamic range will display fewer shades of gray and a more contrasty M-mode display.
Focus Pos		The focus position set in B-mode applies to M-mode as well. Upward presses move the focus shallower, regardless of the U/D invert status of the M-mode. Downward presses move the focus deeper.
Sweep Speed		Sweep adjusts the sweep speed of the M-mode strip. Options of Slow, Low, Med High and Fast are available. Upward presses increase sweep speed. Downward presses decrease sweep speed.

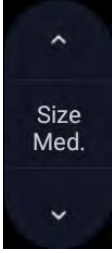
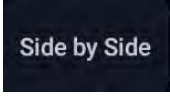
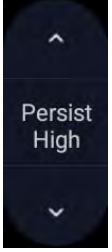
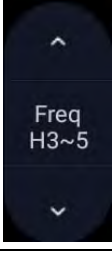
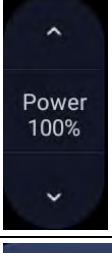
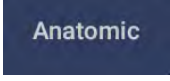
Strip Size		Changes the relative size of the M-mode strip compared to the reference image. Full, large, Med. and small are available.
Side-by-side		This is an on/off control. When On, the M-Mode strip is displayed side-by-side with the B-mode image. When Off, the M-Mode strip is displayed below the B-mode image
Line Persistence		The line Persistence determines how many M-mode lines are averaged together for the display (similar to persistence in B-Mode). Off, Low, Med. and High settings are available.
Frequency		Frequency determines the transmit frequency used by M-Mode. Upward presses increase the frequency. Downward presses decrease the frequency.
Acoustic power		Adjusts the acoustic output power of the activated transducer. It is only available in live imaging. Higher acoustic power numbers correspond to increased sensitivity and penetration in the image, but the ALARA principle should be followed in actual clinical situations.
Anatomic M		Invokes Linear Anatomic M mode. See section 5.6 for details.

Table 5-5 M-Mode Touch Screen Controls

5.6 Anatomic M Mode

Anatomic M mode allows you to manipulate the position and angle of M sample line and displays real-time M strip image. Only phased array transducer supports Anatomic M mode.

5.6.1. Using Anatomic M Mode

1. Press **Anatomic** button on the M-mode touch screen to invoke Anatomic M mode.
2. Press **Show one**, **Show two** or **Show three** button on the touch screen to display single or multiple M sample lines.
3. Use trackball to adjust the position of M sample line.
4. Rotate **<Angle>** knob on the console to adjust the angle of M sample line.
If multiple M sample lines are displayed pressing **<Set>** key can switch between the M sample lines.
5. Adjust image parameters to optimize M strip.

5.6.2. Optimizing Anatomic M Image

For touch screen controls consistent with those in M mode, please refer to section 5.5.2 M-mode Image Optimization. This section only introduces special touch screen controls in Anatomic M mode.

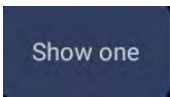
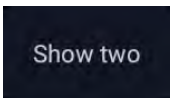
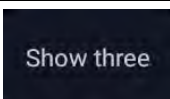
Name	Control	Description
M sample lines		Displays only one M sample line.
		Displays two M sample lines.
		Displays three M sample lines.

Table 5-6 Anatomic M Mode Touch Screen Controls

5.7 TDI Mode

Tissue Doppler Imaging (TDI) mode shows information about low-velocity and high-amplitude tissue motion, usually used to evaluate cardiac tissue motion. Only Phased transducer supports TDI mode.

There are two types of TDI modes available on this system:

- TVI(Tissue Velocity Imaging) mode: shows the speed and direction of tissue motion on real-time Color image.
- TVD(Tissue Velocity Doppler) mode: shows the speed of tissue motion on Strip Doppler image.

5.7.1. Using TDI mode

1. Press **TDI** key on the left side of the touch screen to invoke TVI mode.
2. Use the trackball to adjust the position of ROI box.
3. Press **<PW>** key on the console and use the trackball to move the sample volume gate to desired position.
4. Press **<Update>** key on the console to invoke TVD mode.

5.7.2. TDI Image Optimization

Touch screen controls for optimizing TVI image are the same as those in Color mode, see section 5.2.3 Color Image Optimization for details. Touch screen controls for optimizing TVD image are the same as those in PW mode, see section 5.3.2 PW Image Optimization for details.

5.8 3D/4D Mode

3D/4D mode is only available on a Wobble transducer. There are two ways to activate pre-3D or Pre-4D mode:

1. Press the <3D> or <4D> on the console.
2. Press the 3D or 4D button on the touch screen in B-mode.

5.8.1. Pre-3D/Pre-4D

The Pre-3D and Pre-4D mode supports defining the 3D and 4D acquisition location and settings. Figure 5-1 shows an example of the pre-3D image.

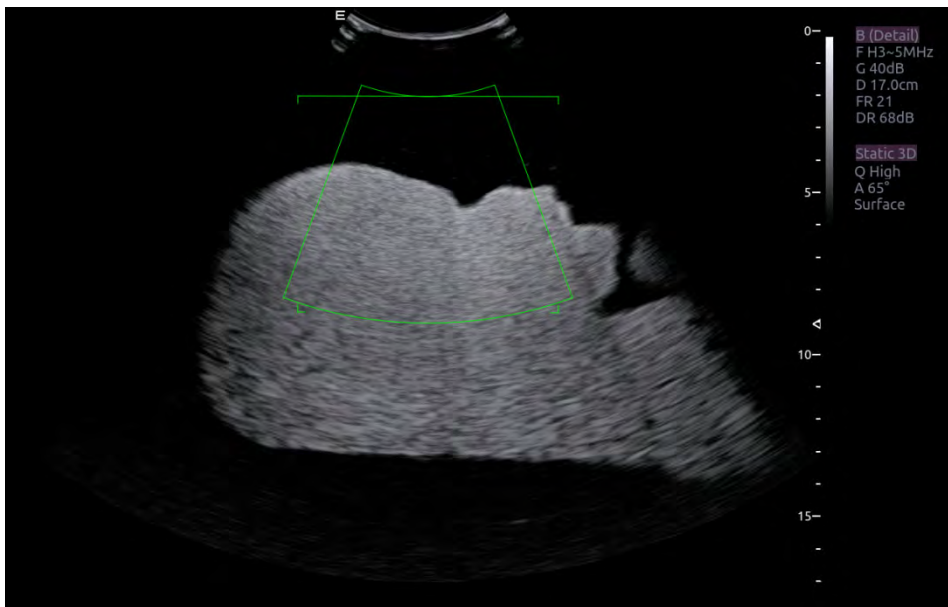
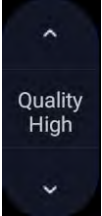
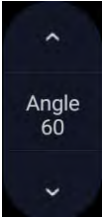


Figure 5-1 Pre-3D Image

The VOI (Volume of Interest) indicates the portion of the image that will be used for 3D. The top horizontal line is the clip plane. The initial volume rendering will show everything below this line. It can be adjusted to a curved line upwards and downwards and its top point can be adjusted to left or right by using the trackball. Also the position/size of the VOI can be adjusted using the trackball. Press <Set> key to toggle among VOI position, VOI size and horizontal line adjusting.

The touch screen controls in Pre-3D and Pre-4D:

Name	Control	Description
Image Quality		Adjusts the trade-off between speed and image quality of the acquisition. Settings include High (quality), Middle, and Fast.
Angle		Adjusts the angle of the volume acquisition. Upward presses increment the angle. Downward presses decrement the angle.

Surface/ Skeleton	<div style="background-color: #333; color: white; padding: 5px; text-align: center; margin-bottom: 5px;">Skeleton</div> <div style="background-color: #444; color: white; padding: 5px; text-align: center;">Surface</div>	These two radio buttons determine if the acquisition is optimized for looking at Skeleton or Surface.
3D	<div style="background-color: #444; color: white; padding: 5px; text-align: center;">3D</div>	Press to switch to Pre-3D.
4D	<div style="background-color: #333; color: white; padding: 5px; text-align: center;">4D</div>	Press to switch to Pre-4D.
Start	<div style="background-color: #333; color: white; padding: 5px; text-align: center;">Start</div>	Start an acquisition.

Table 5-7 Pre-3D Touch Screen

5.8.2. 3D Volume Sweeping

Select **Skeleton** or **Surface** on the Pre-3D touch screen and press **Start** button or **<Update>** key to start image acquisition.

During the process of 3D volume sweeping, the images swept in VOI box are displayed in the image area.

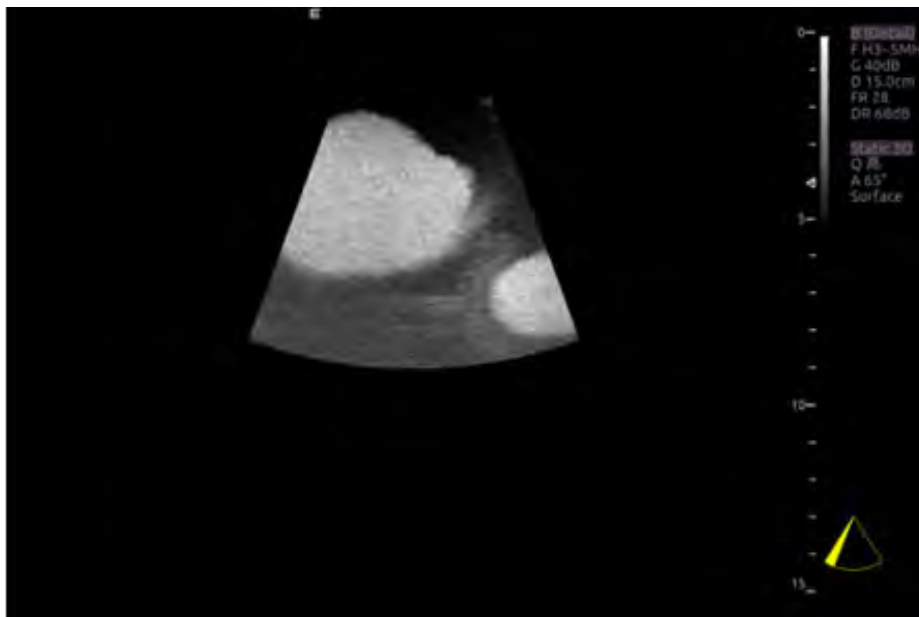



Figure 5-2 3D Image Scanning

While scanning, the sector  in the right bottom is filled gradually, and no buttons on the control panel and touch screen can be activated.

5.8.3. 3D Image Review

The system will enter to the 3D review status after finishing one sweep.

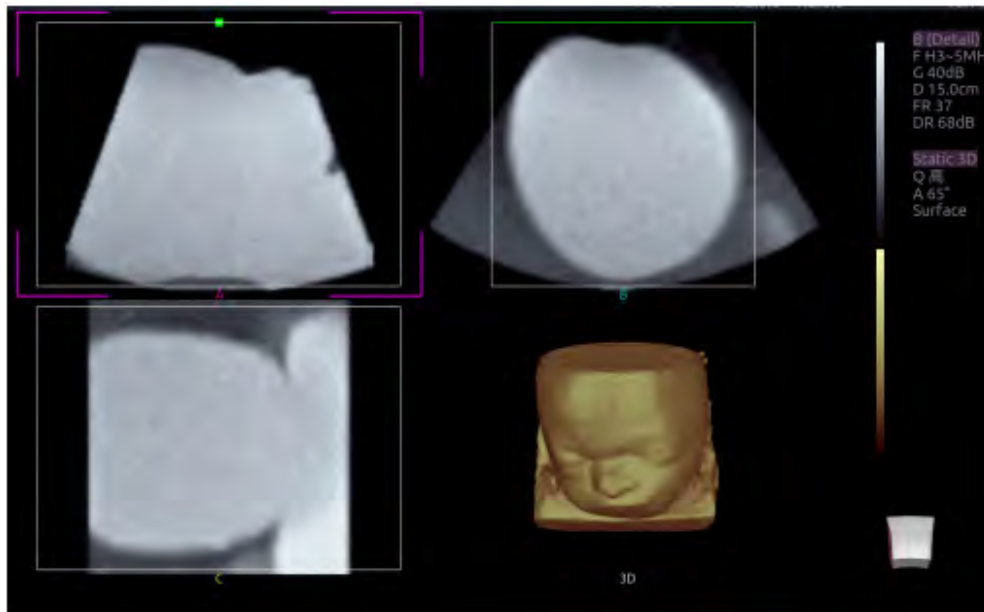


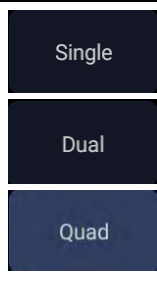




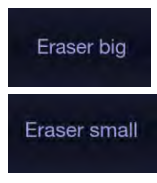
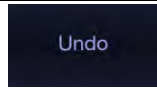
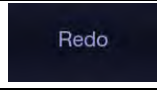
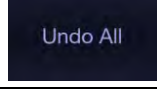
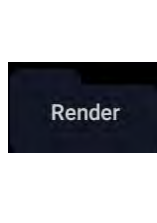
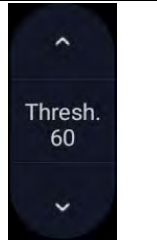
Figure 5-3 3D Image Review

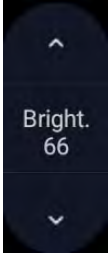
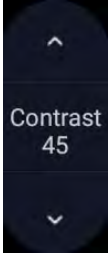

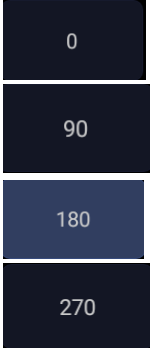
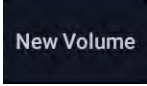
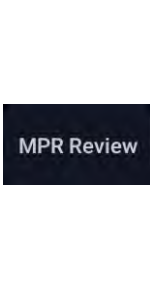
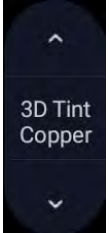
There are two image modes: Volume imaging mode and multi-slice imaging mode. Figure 5-3 shows Volume Imaging Mode in quad screen with a Baby Face volume rendering.

- Quadrant A shows a slice through the data that mimics the original ultrasound image.
- Quadrant B is orthogonal to A, as if the transducer had been rotated 90 degrees.
- Quadrant C is orthogonal to A and B, showing a slice that is parallel to the transducer face.

The following table shows the touch screen controls that are available in Volume Imaging Mode

Name	Control	Description
Volume/ Multi-slice	<input type="radio"/> Volume <input type="radio"/> Multi-Slice	These two radio buttons toggle between the Volume display and the Multi-Slice display.
A/B/C/3D	<input type="radio"/> A <input type="radio"/> B <input type="radio"/> C <input type="radio"/> 3D	These four radio buttons select which quadrant is the focus of the navigation/panning controls. A/B/C are three orthogonal slices through the volume, while '3D' is the rendered image.
Reset	<input type="radio"/> Reset	Reset the operation of pan, rotate and zoom to the initial condition.

<p>Single, Dual, Quad</p>		<p>These three radio buttons switch the display to show 1, 2, or 4 images at once. Single shows the 3D image, dual shows the A slice and 3D image, Quad shows three MPR slices and 3D image.</p>
<p>VOI</p>		<p>Press to activate the function of adjusting VOI or clip plane. Use the trackball to adjust and press <Set> to switch between VOI and clip plane.</p>
<p>Cut</p>		<p>This is a folder of cut functions with various cut tools inside. See below for details.</p>
<p>Cut tools</p>		<p>These are two radio buttons. The region inside or outside the trace will be cut. To draw the trace, move the trackball and press <Set> to locate the start point, use trackball to draw trace and second press <Set> to locate the end point.</p>
		<p>These are two radio buttons. The region inside or outside the box will be cut. To draw the box, move the trackball and press <Set> to locate the top left point, move the trackball and a box is displayed. Press <Set> to locate the lower right point of the box.</p>
		<p>These two radio buttons switch the size of the eraser. To use eraser to cut, move the trackball and press <Set> to locate the first point, move the trackball and the path that the eraser moves is cut, and then press <Set> to complete the cut.</p>
<p>Undo</p>		<p>Undo the previous cut operation</p>
<p>Redo</p>		<p>Redo the previous undo operation</p>
<p>Undo All</p>		<p>Return to the condition before cutting</p>
<p>Render</p>		<p>This is a folder containing various render modes inside. Render modes of Surface and Max. are available. Surface: helpful for surface imaging, for example, fetus face, hand or foot. Max: displays the maximum intensity of gray values in the VOI. This is helpful for viewing bony structures.</p>
<p>Threshold</p>		<p>Adjust the threshold of 3D image.</p>

<p>Brightness</p>		<p>Adjust the brightness of 3D image</p>
<p>Contrast</p>		<p>Adjust the contrast of 3D image.</p>
<p>3D Smooth MPR Smooth</p>		<p>Adjust smoothness of A\B\C slices and 3D images. Higher filter levels create a smoother image. Upward presses increase the filter. Downward presses decrease the filter.</p>
<p>Quick Rotation</p>		<p>Four radio buttons used to quickly rotate the image. Available angles are: 0°/90°/180° /270° .</p>
<p>New Volume</p>		<p>End the 3D volume sweeping and return to the pre-3D interface</p>
<p>MPR Review</p>		<p>MPR (multi-planar reconstruction) review function. After this button is activated, the 3D volume is hidden and two perpendicular lines appear on the selected quadrant. These two lines are color matched with the other 2 MPR quadrants and show where the three planes intersect. Move trackball left/right or up/down to change location of lines and intersection on the MPR's. Moving one line will move the other perpendicular line.</p>
<p>3D Tint</p>		<p>Select 3D tint.</p>

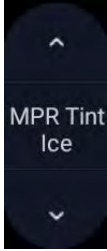

MPR Tint		Select MPR tint.
eFace		Press to show the baby face automatically. Only available in Surface render mode.

Table 5-8 Volume imaging Mode Touch Screen

Image area and touch screen controls in multi-slice imaging mode:

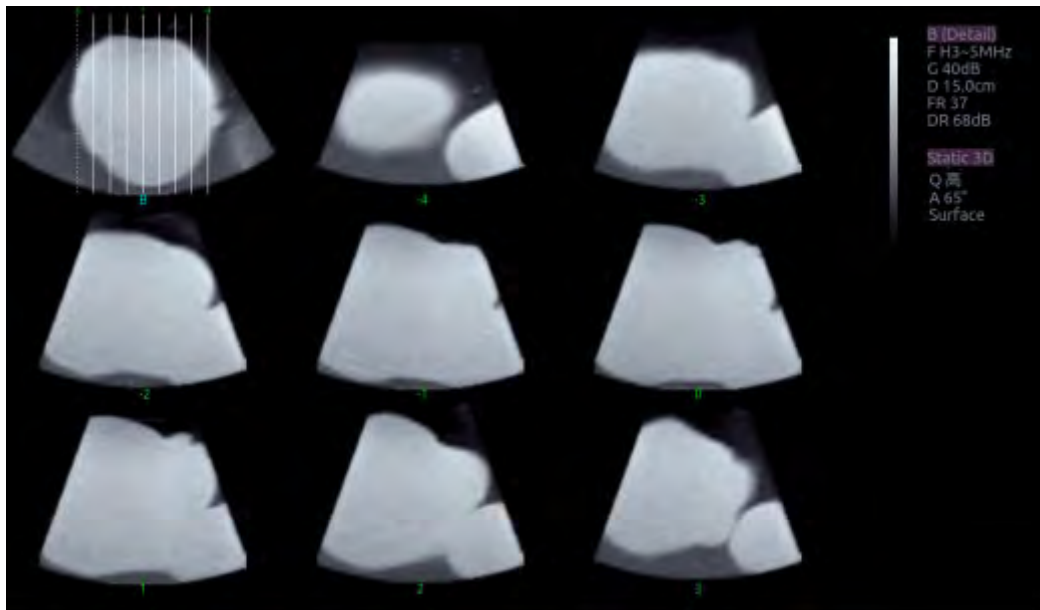
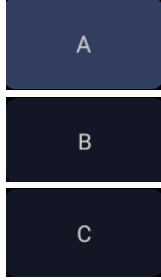
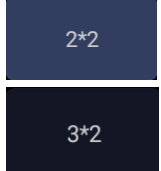


Figure 5-4 Multi-slice Imaging Mode

In figure 5-4, the first image shows the basis slice, other images are orthogonal to the basis slice and parallel to each other. Lines on the basis slice indicate the locations of the parallel slices. If there are more slices than images then the un-displayed slices are shown with a dotted line. A number below each parallel slice shows the slice location in the basis slice, with 0 being the middle slice.

Control	Name	Description
A/B/C		These three radio buttons determine which slice is the required parallel slice. These three choices are the same as on the Volume display in quad mode.
3*3, 2*2, 3*2		These three radio buttons determine the layout of the display.

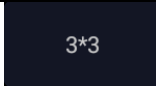
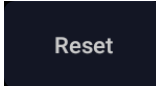
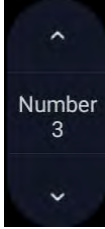
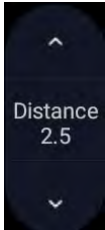
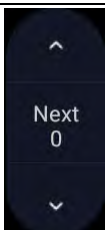
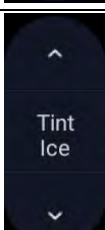
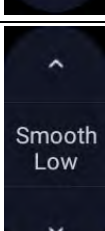
		
Reset		Reset the operation of pan, rotate and zoom to the initial condition.
Number		Select how many slices to use
Distance		Adjust the distance between slices.
Next		When there are more slices than can be displayed at once this control cycles through the subset of slices displayed.
Tint		Select multi-slice tint.
Smooth		Adjust smoothness of A\B\C slices. Higher filter levels create a smoother image. Upward presses increase the filter. Downward presses decrease the filter.

Table 5-9 Multi-slice Mode Touch Screen

5.8.4. 4D Volume Acquisition

In Pre-4D mode, select **Skeleton** or **Surface** first, adjust the VOI box and then press **Start** button on the touch screen or the <Update> key to begin sweep.

5.8.5. 4D Live Volume

4D Live volume continuously sweeps and displays successive 3D volumes. As shown in figure below, image in the left is A slice and image in the right is the live 3D volume rendering.

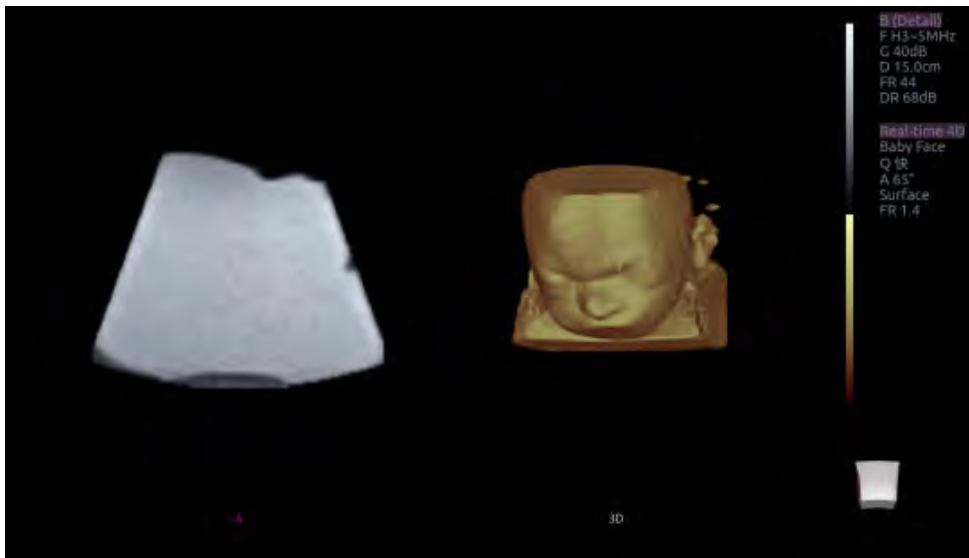


Figure 5-5 4D Volume Sweeping Image

5.8.6. 4D Cine

During the process of 4D live volume imaging, press the **<Freeze>** button on the control panel to enter the 4D cine mode. A cine replay scroll bar appears below the images. Use the trackball to replay the images. For the selected frame, user can execute all operations that are available in 3D review status. Press **<Freeze>** again to return to the live image.

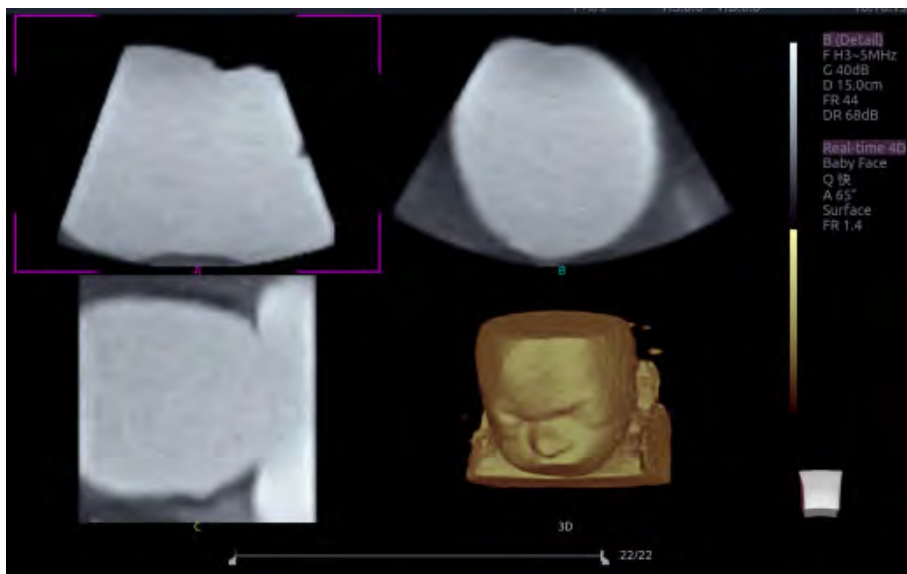


Figure 5-6 4D Cine

5.8.7. Knobs and Buttons on Control Panel

Knobs and buttons on control panel can also be used to make operation more convenient in 3D/4D mode.




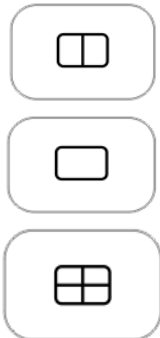
Name	Control	Description
Rotation X		Rotate this knob to rotate the image by the X-axis of the activated window.
Rotation Y		Rotate this knob to rotate the image by the Y-axis of the activated window.
Rotation Z		Rotate this knob to rotate the image by the Z-axis of the activated window.
Single, Dual, Quad		These three hard keys switch the display to show 1, 2 or 4 images at once. Single shows the 3D image, dual shows the A slice and 3D image, and quad shows A/B/C slice and 3D image.

Table 5-10 3D/4D Mode Control Panel

6 Transducers and Biopsy

6.1 Transducers

No.	Model	Type	Application	Applied Region
1	L17-7HQ	Linear	Small Parts(Thyroid, Testes, Breast) Peripheral Vascular Musculoskeletal	Body Surface
2	P5-1Q	Phased array	Adult Cardiac Abdominal Pediatric Cardiac Adult Cephalic	Body Surface
3	E8-4Q	Micro Convex	Fetal / Obstetrics Trans-vaginal Trans-rectal Urology Gynecology	Intra-cavity
4	C5-2Q	Convex	Abdominal Fetal / Obstetrics Urology Gynecology Musculoskeletal	Body Surface
5	L12-5Q	Linear	Abdominal Small parts(Thyroid, Testes, Breast) Peripheral Vascular, Musculoskeletal	Body Surface
6	L17-7SQ	Linear	Intra-operative Musculoskeletal Peripheral Vascular	Body Surface/ Intra-operative
7	MC8-4Q	Micro Convex	Pediatric Abdominal Neonatal Cephalic Musculoskeletal Peripheral Vascular	Body Surface
8	MC9-3TQ	Micro Convex	Pediatric Abdominal Neonatal Cephalic Peripheral Vascular Musculoskeletal	Body Surface

9	P7-3Q	Phased Array	Adult Cardiac Pediatric Abdominal Pediatric Cardiac Neonatal Cephalic	Body Surface
10	C7-2XQ	Convex	Abdominal Fetal / Obstetrics Urology Gynecology Musculoskeletal	Body Surface
11	E10-3BQ	Micro Convex	Fetal / Obstetrics Trans-vaginal Trans-rectal Urology Gynecology	Intra-cavity
12	E10-3HQ	Micro Convex	Fetal / Obstetrics Trans-vaginal Trans-rectal Urology Gynecology	Intra-cavity
13	C6-2MQ	Convex	Fetal / Obstetrics Abdominal Gynecology	Body Surface
14	C5-1Q	Convex	Abdominal Fetal / Obstetrics Urology Gynecology Musculoskeletal	Body Surface

Table 6-1 Transducer Model & Application

6.2 Using Transducers

Understanding a Transducer:

Figure 6-1 takes L12-5Q transducer to show an example of a transducer.

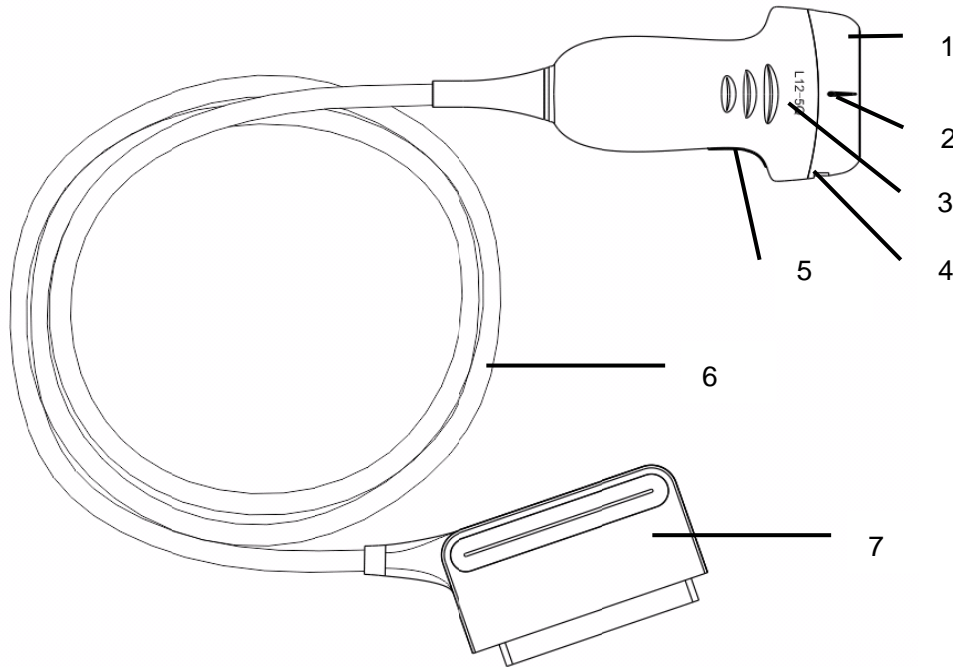


Figure 6-1 Typical transducer

No.	Name	Function
1	Transducer head	Converts electrical signals to sound waves, and then converts received echoes back to electrical signals. The tip of the transducer is the acoustic lens.
2.	Center line mark	Indicates the center line position of the transducer, which are usually used for out-of-plane needle guide.
3.	Transducer model	Displays the transducer model.
4	Needle-guided bracket fixing tabs and groves	Provides mounting support for the needle-guided bracket.
5.	Transducer orientation mark	The side of orientation mark on the transducer corresponds to the side of orientation mark on the display screen
6	Transducer cable	Transmits electrical signals between the transducer head and the transducer connector.
7	Transducer connector	Connects the transducer to the ultrasound imaging system.

Image Orientation Mark

The image orientation mark on the display screen and on the transducer are shown as below. The side of orientation mark on the transducer corresponds to the side of orientation mark on the display screen. Ensure orientation marks on the display screen and transducer are on the same side prior to scanning.

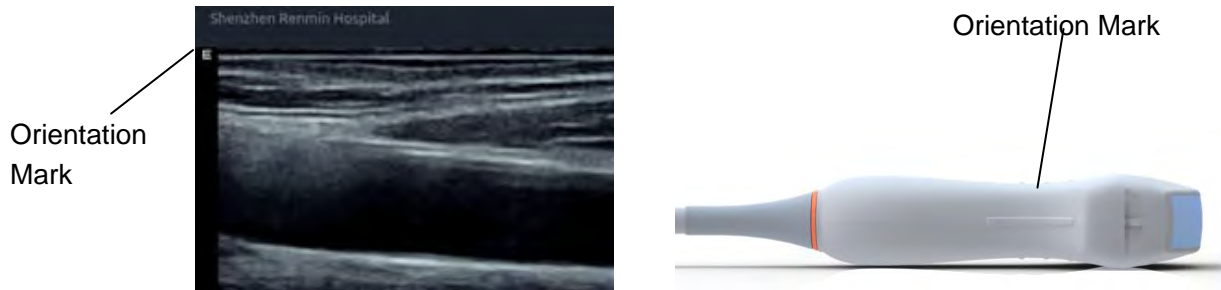


Figure 6-2 Image Orientation Mark

Proper Use of Transducers

To extend the service life and maintain optimum transducer performance, please operate as follows:

- Inspect transducer cable, socket and acoustical window of the transducer periodically.
- Shut down the machine before connecting or disconnecting the transducer.
- Do not drop the transducer onto the floor or collide with hard objects. Otherwise it will be damaged easily.
- Do not heat the transducer.
- Do not pull or bend the transducer cable.
- Coupling gel can only be used on the head of the transducer, and it should be wiped off after use.
- Clean and disinfect the transducer after every use.
- The acoustical window and the shell of the transducer should be examined frequently.

CAUTION

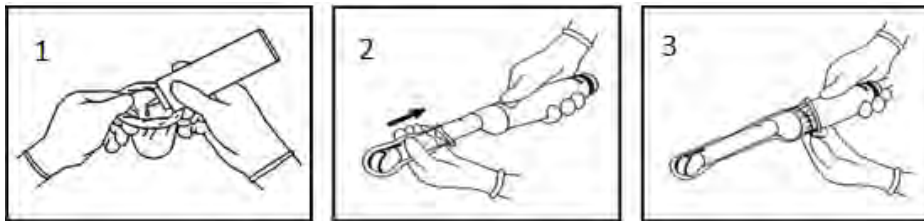
1. Do not disinfect or clean transducers under high temperature. The temperature should be below 45°C.
 2. To avoid damaging the device, the disinfection method is limited to regular maintenance of devices in hospitals. Disinfecting instruments should be cleaned first.
 3. The coupling gel adapted to the transducer is a medical ultrasound coupling gel. Use only ultrasound coupling gel that complies with local regulations.
-

Use of Transducer sheath

CAUTION

1. Always wear gloves to perform the following steps.
2. To minimize disease transmission, legally marketed, sterile transducer sheath is required to use for intra-cavitary and intra-operative procedures.
3. Use a pyrogen-free transducer sheath for intra-operative procedures.
4. DO NOT use an expired transducer sheath. Check whether the term of validity has expired prior to using transducer sheaths.
5. The single-use sheath should comply with the local regulations.
6. Before cleaning or disinfecting the transducer, remove the sheath gently and discard it. Put on a new single-use sheath before using the transducer.
7. Use of protective sheath with natural rubber latex may lead to a severe anaphylactic reaction in persons sensitive to the natural latex protein.
8. Transducer sheath should be used with all clinical situations where infection is a concern.

To install transducer sheath:



1. Place an adequate amount of sterile coupling gel in the protective sheath and/or on the acoustic window of the transducer;
2. Insert the transducer into the sheath;
3. Pull the sheath over the transducer and cable until the sheath is fully extended. Check and eliminate bubbles between the surface of the transducer and the sheath. Be careful not to pierce the sheath.
4. Secure the sheath using the bands or clips supplied with the sheath;
5. Inspect the sheath to ensure that there are no damages (i.e. holes or tears).

6.3 Transducer Cleaning and Disinfecting

Transducers should be cleaned and/or disinfected as necessary or between use with a recommended cleanser or disinfectant. Disconnect the transducer from the system prior to cleaning and disinfecting.

6.3.1. Cleaning

The validated cleaning agents for cleaning the transducers are:

- Ethanol (75%)
- Isopropanol (70%)

Cleaning agents should be applied and removed using a clean, soft, sterile, non-abrasive cloth or paper towel.

To clean the transducers:

1. Disconnect the transducer from the system.
2. Wear sterile protective gloves to prevent infection.
3. Remove all residual foreign matters from the transducer using sterile cloth or paper towel immediately after examination. For the situation where a protective sheath is used, the protective sheath should be removed first and discarded.
4. Wipe the surface of transducer and cable with a sterile cloth dampened with the cleaning solution until no visible contaminants remain.
5. After cleaning, wipe off the cleaning solution with a new sterile cloth or towel dampened with tap water until no visible cleaning agent remains.
6. Wipe off with a dry sterile cloth to remove residual moisture.
7. Leave the transducer to air dry.
8. If the transducer is not visually clean at the end of the cleaning steps, please repeat the cleaning steps through step 4 to step 7.
9. Inspect the transducer to ensure that there is no damage. The transducer should be disposed of properly when any damage is found.

WARNING

1. Unplug the transducer from the system prior to cleaning or disinfecting.
2. To avoid infection, always use protective gloves when performing cleaning and disinfecting procedures.
3. Prohibit infiltration of any type of liquid into the device or the transducer.

6.3.2. Disinfecting

Selecting a proper way to disinfect your transducers based on your transducer applied region:

<i>Transducer Applied Region</i>	<i>Transducer Type</i>	<i>Disinfecting Intensity</i>	<i>Disinfecting Method</i>
Contact intact body surface	Body surface	LLD	Spraying or wiping
Contact mucous membrane	Intra-cavity	HLD	Immersion
Contact normally sterile tissue	Intra-operative	Sterilization	Immersion

Note: LLD=Low-level Disinfection; HLD=High-level disinfection

The validated disinfectants for transducer are:

<i>Disinfectants</i>	<i>Disinfecting Intensity</i>	<i>Disinfecting Method</i>
Ethanol (75%)	LLD	Spraying or wiping
Isopropanol (70%)	LLD	Spraying or wiping
Cidex OPA (0.55%)	HLD	Immersion
Cidex Glutaraldehyde(2.4%)	HLD, Sterilization	Immersion

WARNING

1. Unplug the transducer from the system prior to cleaning or disinfecting.
2. To avoid infection, always use protective gloves when performing cleaning and disinfecting procedures.
3. To avoid infection, ensure that expiration date of the disinfecting solution has not passed.
4. Please cleaning the transducer prior to disinfection.

Disinfecting by spraying or wiping:

1. Disconnect the transducer from the system.
2. Wear protective gloves to prevent infection.
3. Clean and dry the transducer according to the methods in section *6.3.1 Cleaning*.
4. Prepare the disinfectant solution (75% ethanol or 70% isopropanol).
5. Spray the solution to the transducer interface or wipe it with a sterile cloth dampened with the disinfectant solution. Follow the disinfectant manufacturer's recommended contact time and mode.
6. Rinse the transducer according to the disinfectant instructions. Wipe the transducer with a dry sterile cloth or leave the transducer to air dry.
7. Inspect the transducer to ensure that there is no damage.

Note:

If Ethanol or Isopropanol is used for both cleaning and disinfecting, then a new sterile cloth is required for the disinfection step.

Disinfecting by Immersion:

1. Disconnect the transducer from the system.
2. Wear protective gloves to prevent infection.
3. Clean and dry the transducer according to the methods in section *6.3.1 Cleaning*.
4. Prepare the disinfectant solution (Cidex OPA 0.55% or Cidex Glutaraldehyde 2.4%). Refer to the instructions provided by the disinfectant manufacturer for the concentration of the disinfection solution, method of dilution, method of disinfection, temperature and cautions during use.
5. Place the cleaned and dried transducer in contact with the disinfectant (refers to figure 6-3 for the contacting area) for the time specified by the disinfectant manufacturer. For example, the contact time recommended by the manufacturer for soaking in Cidex Glutaraldehyde(2.4%) is at least 45 min.

6. Rinse the transducer thoroughly with sterile water to remove all chemical residues. For example, it is required to flush the transducer after soaking in Cidex Glutaraldehyde(2.4%) with plenty of sterile water (about 2 gallons) at least one time. Or, follow the complete rinsing instructions provided by the disinfectant manufacturer to rinse the transducer.
7. Wipe off the water on the transducer with a dry sterile cloth. Leave the transducer to air dry.
8. Inspect the transducer to ensure that there is no damage.

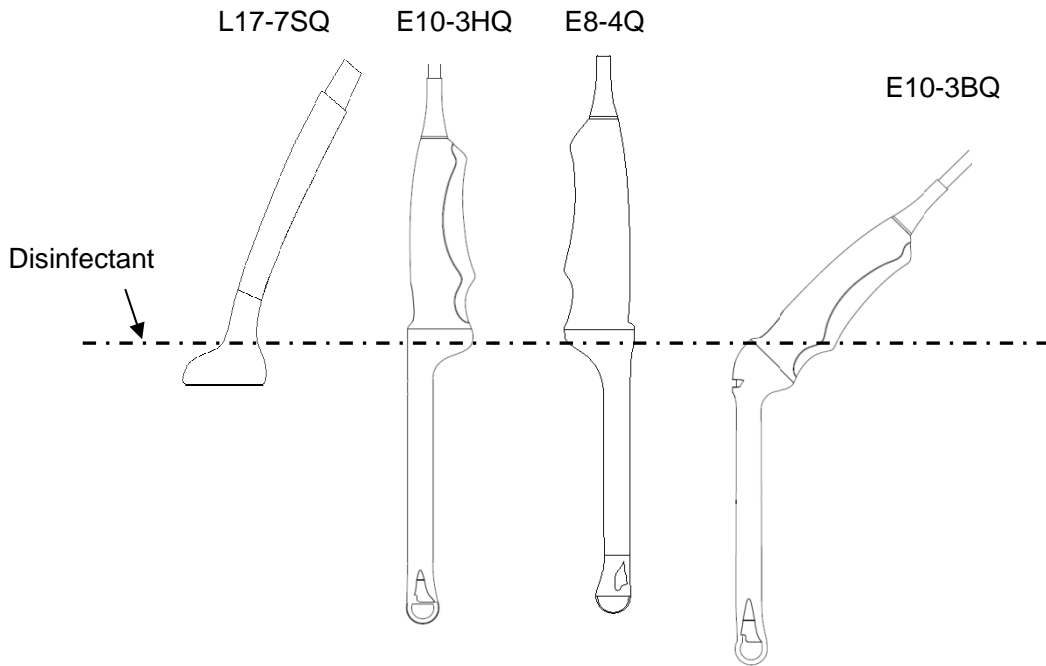


Figure 6-3 Depth of the Transducer Immersed into Disinfectant

WARNING

1. Do not immerse the transducer connector. If the cable connector is immersed, do not plug the connector into the system. Rinse the connector under running water and dry it thoroughly. If necessary, contact EDAN for service.
2. Prohibit infiltration of any type of liquid into the device or the transducer.
3. Do not immerse the cable and connector of the transducer into solutions. Transducers can be submerged to, but not including, the strain relief of the transducer array. Do not immerse or soak any part of a transducer in any cleaning material not listed in the recommended list of disinfectant.
4. Use the immersion method to disinfect the intra-cavitary and intra-operative transducers.
5. Only non-immersion method can be used with solution of ethanol or isopropanol.
6. The immersion time should not exceed the time that is specified by the disinfectant manufacturer.
7. Patient contact area should be immersed into the solution while using the immersion method, but should not exceed the depth shown in figure 6-3.

6.3.3. Sterilization

Intra-operative transducers must be sterilized after each exam.

Sterilizing the transducers:

1. Disconnect the transducer from the system.
2. Wear protective gloves to prevent infection.
3. Clean and dry the transducer according to the methods in section *6.3.1 Cleaning*.
4. Prepare the disinfectant solution (Cidex Glutaraldehyde 2.4%). Refer to the instructions provided by the disinfectant manufacturer for the concentration of the disinfection solution, method of dilution, method of disinfection, temperature and cautions during use.
5. Place the cleaned and dried transducer in contact with the disinfectant (refers to figure 6-3 for the contacting area) for 10 hours. Or, follow the time specified by the disinfectant manufacturer to soak the transducer.
6. Flush the transducer with plenty of sterile water (about 2 gallons) at least one time. Or, follow the complete rinsing instructions provided by the disinfectant manufacturer to rinse the transducer.
7. Wipe off the water on the transducer with a dry sterile cloth. Leave the transducer to air dry.
8. Inspect the transducer to ensure that there is no damage.

WARNING

1. Do not sterilize the transducer using techniques such as autoclave, ultraviolet, gamma radiation, gas, steam, or heat. Severe damage may result.
2. If L17-7SQ transducer is applied to normally sterile tissue without using a sterile sheath, it must be sterilized. If L17-7SQ transducer is applied to normally sterile tissue using a sterile sheath, it should be sterilized, or disinfected(High-level disinfection).

6.3.4. Storage

WARNING

1. Dry the transducer after high-level disinfection or sterilization and store it in sterile environment.
 2. Do not use the carrying case for storing the transducer, because the carrying case may become a source of infection.
-
1. Ensure the transducer is cleaned, disinfected, sterilized and completely dried before storage.
 2. Store the transducer in a sterile environment or in a disposable sterile package.
 3. Store the transducer under the following conditions:
 - a) Atmospheric Temp.: -20°C ~ +55°C
 - b) Relative Humidity: 15%~95% (Non-condensing)
 - c) Atmospheric Pressure: 70kPa ~ 106kPa.

6.4 Needle Biopsy Guide

NOTE:

Use proper sterile technique at all times when performing a biopsy.

Always follow these basic precautions:

WARNING

1. The needle guide bracket kits are not disinfected or sterilized before delivery. Sterilize the needle guide kit before the first use and after each use.
 2. Calibrate the needle guide kit (see section 6.4.3) under any of the following conditions:
 - a) The first time that each bracket/transducer combination is used.
 - b) If the bracket or transducer head is dropped or struck, or has evidence of wear.
 - c) If previous use has shown some drift of the needle from the center of the guidelines.
 3. The displayed needle guide pathway on the EDAN video monitor is intended for reference during biopsy procedures. A variety of factors outside EDAN's control, such as changing tissue density, bending of the needle, off-axis pressure by the person holding the transducer, etc., may cause deflection of a needle outside of the displayed video pathway even when the transducer, needle guide, and the system software are all performing as intended and within manufacturing specification. The specialist performing a biopsy procedure must be aware of potential external factors when performing an invasive procedure.
 4. Do not freeze the system when performing a biopsy.
 5. EDAN needle guides are designed and manufactured to attach firmly to designated transducers and should not require excessive force to assemble or disassemble. Do not use a needle guide that requires excessive force or manipulation to assemble or disassemble.
 6. A single-use sheath should be used on transducer when performing a biopsy.
-
-

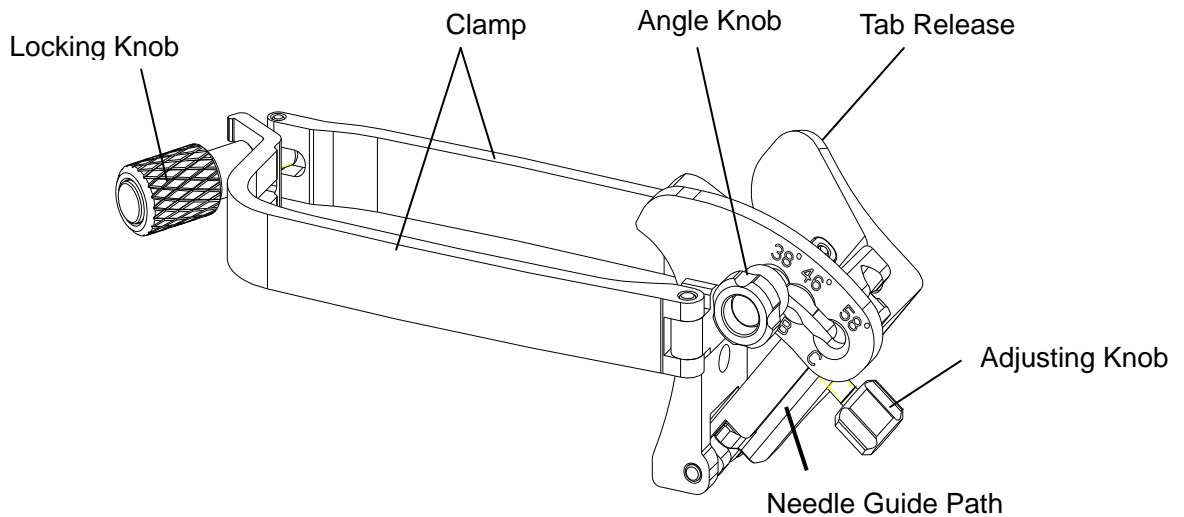
6.4.1. Installing Needle Guide Bracket

WARNING

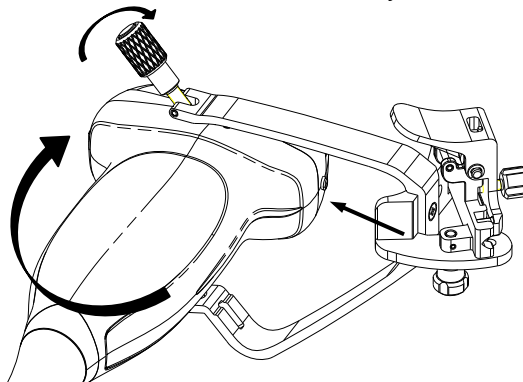
1. For illustration purpose only, transducer and bracket may be shown without a protective sheath. Always place a protective sheath on transducer and bracket to protect cross infection.
-
-

■ **BGK-C5-2/ BGK-002/BGK/BGK-007/BGK-008/BGK-009/BGK-012**

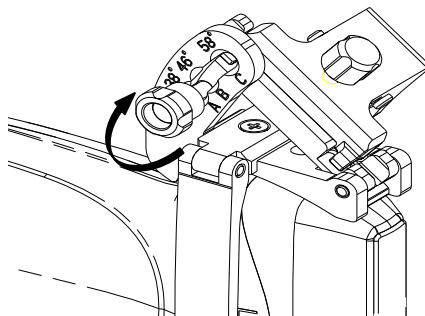
The installation steps for these brackets are the same. Here we take one bracket for illustration.

Structures:**Installation and Use Steps:**

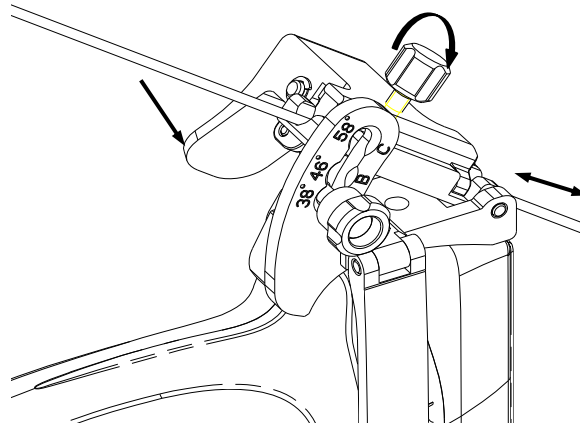
1. Place an appropriate amount of gel on transducer surface, and insert transducer into the sheath.
2. Loosen the locking knob to open the clamp of bracket. Attach the bracket to the transducer by aligning the locating markers on the bracket and the transducer. Properly secure the clamp of bracket with the locking knob. Ensure the bracket is firmly attached.



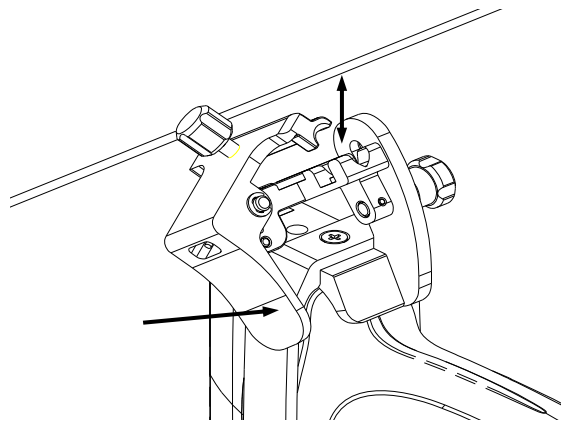
3. Loosen the angle knob to select a needle guide angle, and secure the angle knob.



4. Press the tab release and place the biopsy needle into the needle guide path. Use the adjusting knob to properly secure the needle.



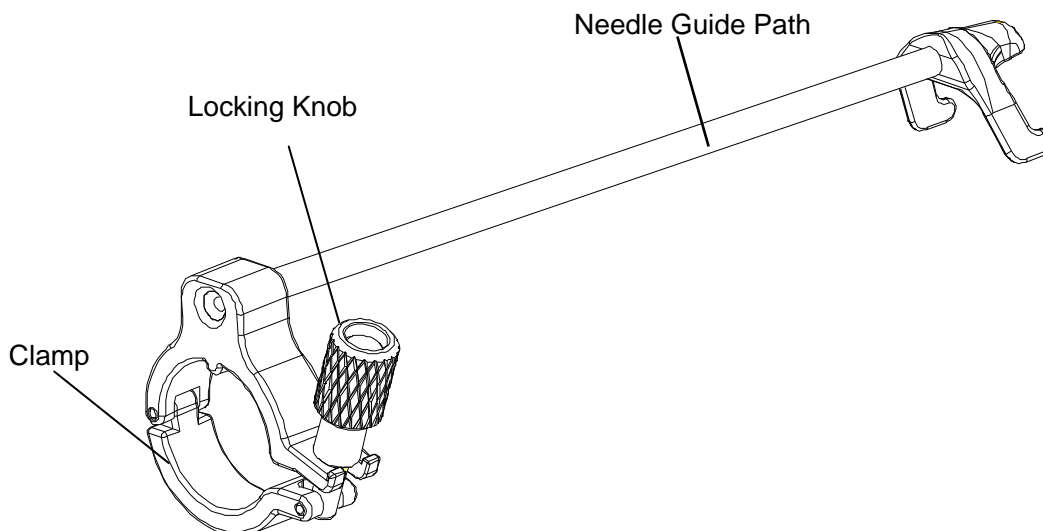
5. After biopsy, press the tab release to remove the needle, and loosen the locking knob to remove the bracket from the transducer.



■ **BGK-CR10UA/BGK-006**

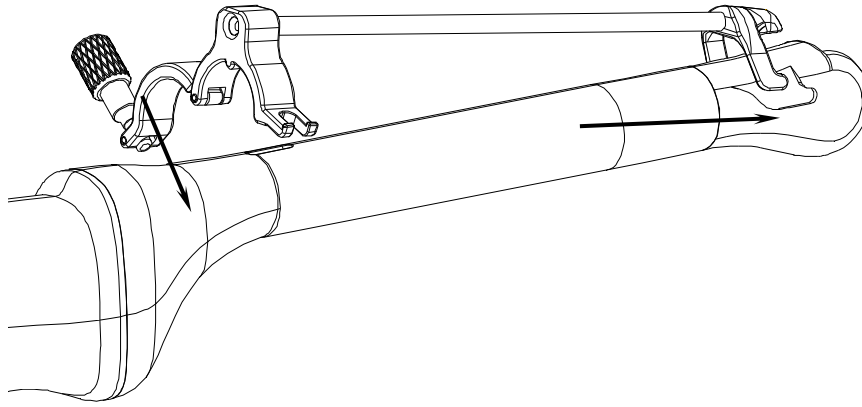
The installation steps for these brackets are the same. Here we take one bracket for illustration.

Structures:

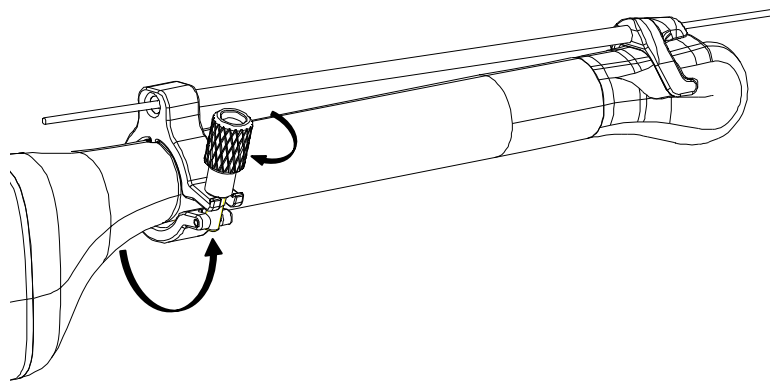


Installation and Use Steps:

1. Place an appropriate amount of gel on transducer surface, and insert transducer into the sheath.
2. Loosen the locking knob to open the clamp of bracket. Attach the bracket to the transducer by aligning the locating markers on the bracket and the transducer.

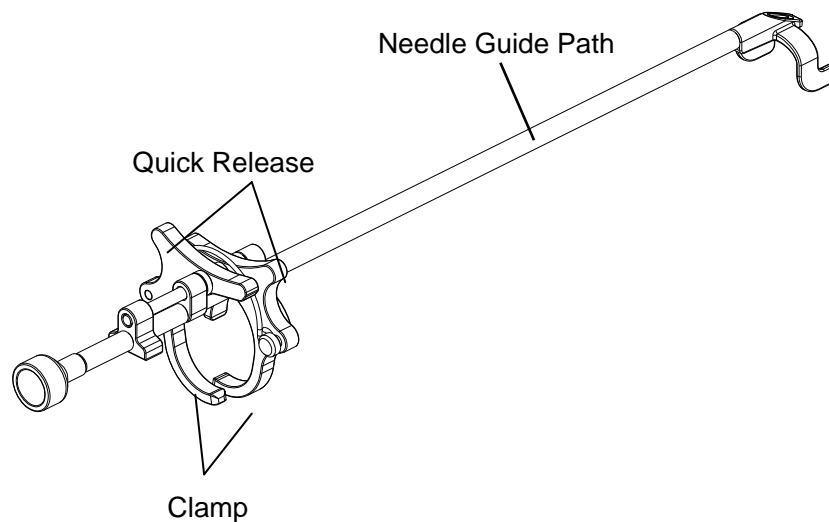


3. Properly secure the clamp of bracket with the locking knob. Ensure the bracket is firmly attached, and then place the biopsy needle into the needle guide path.



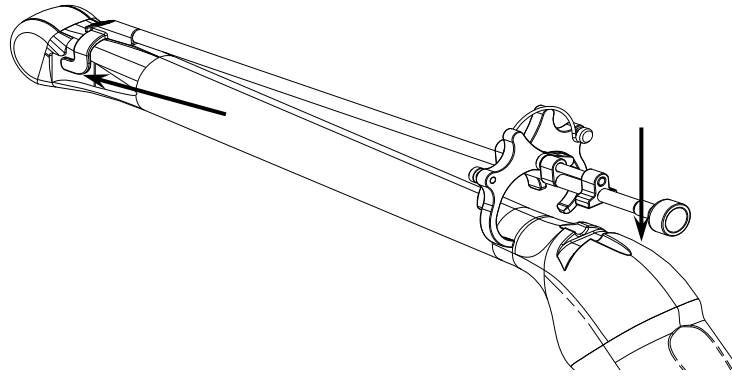
■ BGK-005

Structures:



Installation and Use Steps:

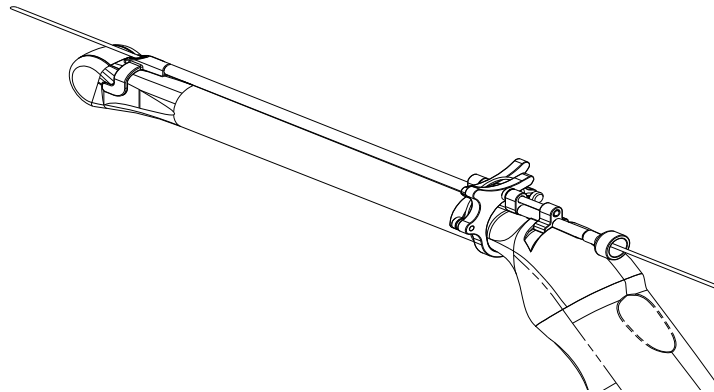
1. Place an appropriate amount of gel on transducer surface, and insert transducer into the sheath.
2. Use the quick release to open the clamp of bracket. Align the locating markers on the bracket and the transducer and push the bracket to click into place.



3. Press the left and right side of the clamp as the figure below to attach the bracket to the transducer firmly.



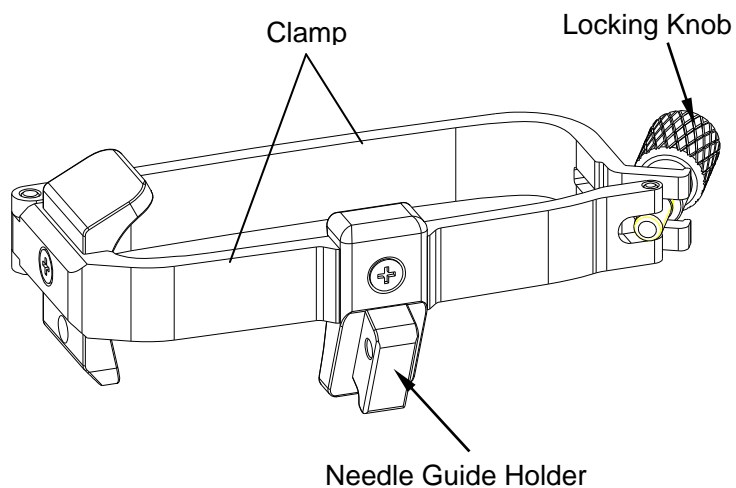
4. Ensure the bracket is firmly attached, and then place the biopsy needle into the needle guide path.



■ **BGK-003**

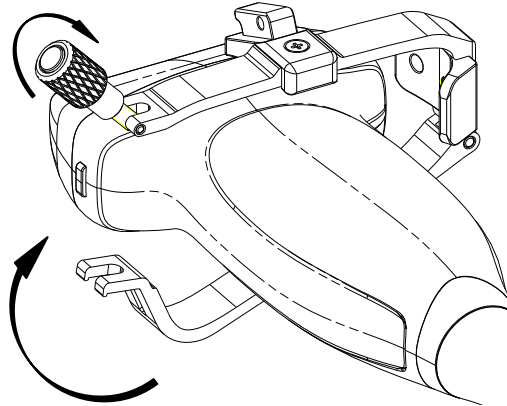
The installation steps for these brackets are the same. Here we take one bracket for illustration.

Structures:



Installation and Use Steps:

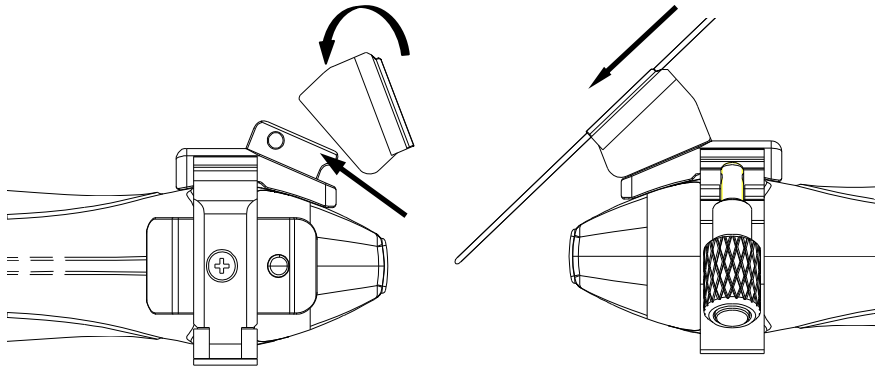
1. Place an appropriate amount of gel on transducer surface, and insert transducer into the sheath.
2. Loosen the locking knob to open the clamp bracket. Attach the bracket to the transducer by aligning the locating markers on the bracket and the transducer. Properly secure the clamp of bracket with the locking knob.



3. Install the disposable Needle Guide.
 - a. Select appropriate disposable needle guide to achieve target depth from skin line:

Specification	Depth
21G (1.0cm)	0.8 - 1.2 cm
21G (1.5cm)	1.3 - 1.7 cm
21G (2.0cm)	1.8 - 2.2 cm

- b. Install the needle guide to the needle guide holder, and then put in the biopsy needle:

**6.4.2. Activating Needle Guide Function**

To enable the needle guide function:

1. In the B mode imaging, press **Needle** button on touch screen. A needle touch screen UI is displayed. Press **Enable** button to activate the Needle Guide function.
2. Press **Double Line** button to switch double line and single line as the Needle guide Line graphics.
3. Some needle guide brackets support multiple angles. If the current transducer supports such a guide then the **Line** paddle key appears. Pressing it selects guide lines of different angles. Each line represents a corresponding angle marked on the needle guide bracket.



Figure 6-4 Needle Guide Touch Screen

WARNING

1. To avoid patient injury when using a multi-angle bracket, make sure that the same angle(A, B, C or D) is selected on both the bracket and the ultrasound system.

6.4.3. Calibrating the Needle Guide Line**WARNING**

2. Calibrate the needle guide under any of the following conditions:
 - a) The first time a needle guide is used with a given transducer.
 - b) Any time the needle guide or transducer has been dropped or struck against a hard surface.
 - c) After repeated use.
3. Do not use the needle guide bracket if the needle does not track with the guide during calibration.

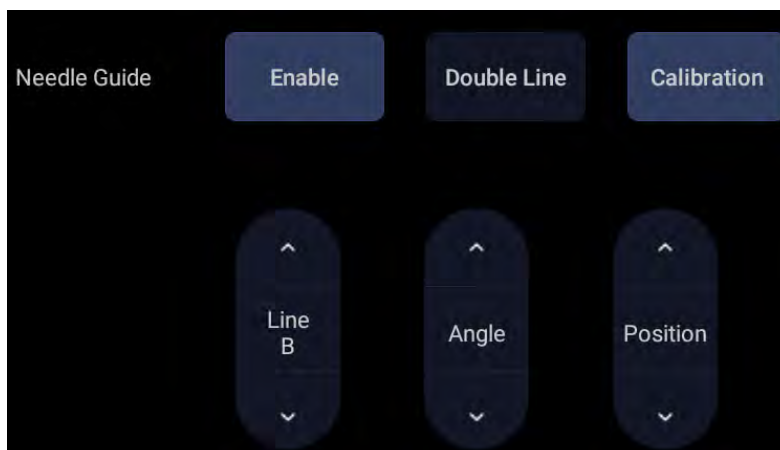


Figure 6-5 Needle Guide Calibration Touch Screen

To calibrate the guide line

1. Assemble the needle guide bracket on the transducer, and use the transducer to image a water bath or needle guide phantom.
2. From the Needle function on the B-mode touch screen, press the **Line** paddle key to select a guide line.

3. Press the **Calibration** button on the touch screen to display the **Angle** and **Position** paddle button.
 - Use the **Position** paddle to adjust the line horizontally until the origin aligns with the actual needle.
 - Use the **Angle** paddle to adjust the angle of the line until the entire line aligns with the actual needle.
4. Any changes will be saved as the default value automatically.

6.5 Needle Visualization

Needle Visualization is an image processing technology that enhances needle visibility. It is available in B-mode for all linear transducers.



Figure 6-6 Needle Enhancement Visualization

Needle Visualization is invoked by pressing the **Needle** button on B-mode touch screen, and then the **Enable** button in the Needle Visualization section of the Needle touch screen. The following parameters can be adjusted when it is active.

- **Enable:** Enables or disables Needle Visualization.
- **L/R:** press to display the angle line on left side or right side of the image field.
- **Shallow/Medium/Steep:** press to enhance the needle visibility for different needle inserted angles. For best results use the angle line that is closest to perpendicular to the needle path.

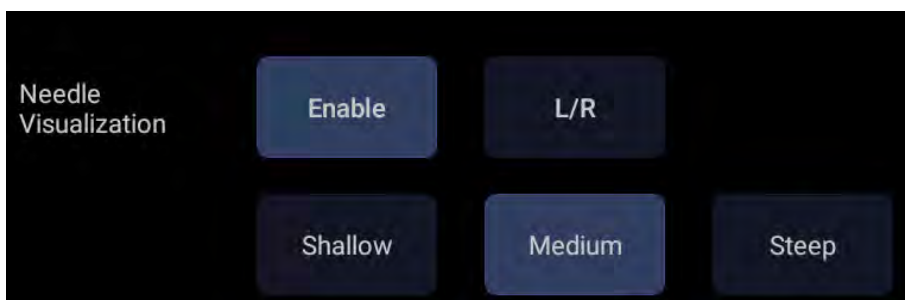


Figure 6-7 Touch Screen for Needle Enhancement Visualization

6.6 Center Line

The Center Line is a vertical dotted line displayed at the middle of the image field, representing the middle of ultrasound beam. The Center Line helps to locate the position and depth of a target disease focus for out-of-plane biopsy, lithotripsy and etc..

To use Center Line:

1. Press **Center-Line** on B-mode touch screen to activate Center Line.
2. A dotted center line with a depth marker is displayed vertically at the middle of the image field. The position and direction of the center line cannot be changed.
3. Move the transducer to locate the target.
4. Move the marker to the target and its depth will be displayed below the image.

Note:

Center Line is not available on Intra-cavity transducer E8-4Q.

6.7 Needle Guide Bracket Cleaning and Sterilization

NOTE:

1. Use proper sterilization technique at all times when performing a biopsy.
2. Ensure that protective gloves are worn.

WARNING

1. The needle guide bracket kits are not disinfected or sterilized before delivery. The operators must clean and sterilize the needle guide bracket kits before the first use and after each use.
 2. Inspect the bracket for damage such as cracks or breakage. If damage is evident, discontinue use of bracket and contact your Edan representative for disposal guidance.
 3. Sterilize the bracket before disposal or sending back to manufacturer for repair.
-

6.7.1. Cleaning

1. Wear sterile protective gloves to prevent infection.
2. Disconnect the needle guide bracket from the transducer after each use, and remove all visible residues from the needle guide bracket using a small and soft-bristled brush or other similar devices. Do the cleaning quickly before the needle guide bracket dries out.
3. Soak the needle guide bracket in the cleaning solution (Ethanol 75% or Isopropanol 70%) for at least five minutes. Use a soft-bristled brush to clean the needle guide bracket during the soaking.
4. Take out the needle guide bracket from the cleanser and wipe all residues with a sterile cloth.
5. Let the bracket air dry, or dry the bracket with a sterile cloth.
6. If the bracket is not visually clean at the end of the cleaning steps, please repeat the cleaning steps through step 3 to step 5.
7. Inspect the bracket to ensure that there is no damage. The bracket should be disposed of properly when any damage is found.

6.7.2. Sterilization

1. Wear sterile protective gloves to prevent infection.
2. Disconnect the bracket from the transducer, and remove all visible residues from the bracket using sterile cloth.
3. Clean and dry the bracket according to the methods in *section 6.7.1 Cleaning*.
4. Sterilize the bracket assembly by dynamic air removal steam sterilizer for at least four minutes at 132° C. Dry the bracket for at least 30 min after sterilization.
5. Inspect the bracket to ensure that there is no damage.

6.7.3. Storage

WARNING

1. Dry the bracket after sterilization and store it in sterile environment.
 2. Do not use the carrying case for storing the bracket, because the carrying case may become a source of infection.
-
1. Ensure the bracket is cleaned, sterilized and completely dried before storage.
 2. Store the bracket in a sterile environment or in a disposable sterile package.
 3. Store the bracket under the following conditions:
 - a) Atmospheric Temp.: -20°C ~ +55°C
 - b) Relative Humidity: 15%~95% (Non-condensing)
 - c) Atmospheric Pressure: 70kPa ~ 106kPa.

7 Features

7.1 Comment

The Comment function allows you add annotation to an image. The Comment function is invoked by pressing the <Comment> hard key on the console. Figure 7-1 shows an example touchscreen for the Comment function. The top portion of the screen shows comments that are pre-defined in pre-sets. See section 10 for details on how to configure these. The bottom portion of the screen shows controls available while the Comment function is active. Table 7-1 gives an overview of these controls.

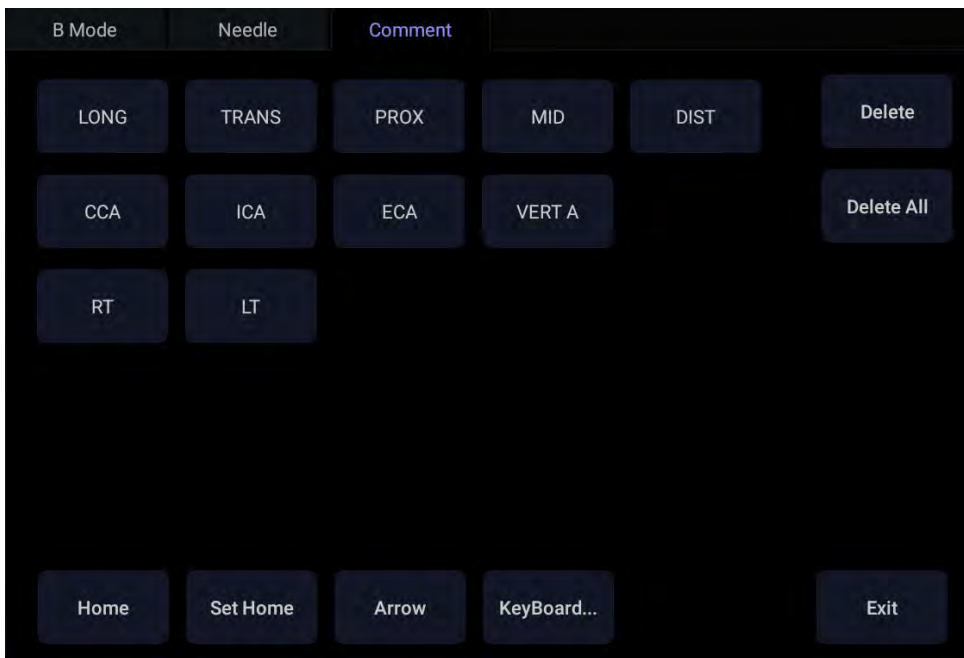


Figure 7-1 Comment Touch Screen

Button	Description
Home	Set the cursor in a pre-defined location.
Set Home	Set the current cursor location as the new Home location
Delete	Delete a whole text or text group or an arrow
Delete All	Clear all comments on the image area
Arrow	Create a new arrow for annotating
Keyboard	Show or hide a touch screen keyboard.
Exit	Press to exit the comments function.

Table 7-1 Comment Touch Screen Description

Adding comments

You can add either pre-defined comments or use a keyboard.

➤ **Adding comments using the keyboard**

1. Invoke the Comment function.
2. Use the keyboard of the system or press the "**Keyboard**" touch screen key to display a keyboard on the touch screen.
3. Move the cursor to the desired location and type the desired text.

➤ **Adding comments using pre-defined comments**

1. Invoke the Comment function
2. Move the cursor to the desired location and press the desired pre-defined comment.

Some of the pre-defined comments may be grouped together with a border surrounding them (such as 'Rt' and 'Lt' in figure 7-1). These are special keys that let you quickly replace one term with another, regardless of where the cursor is within a block of text. For example, if you had entered "Rt. Kidney" as a block of text, pressing the "Lt." button would change that block to "Lt. Kidney" even if the cursor is not at the specific location.

➤ **Adding arrows**

1. Invoke the Comment function.
2. Press **Arrow** button on the touch screen to display an arrow at the current cursor location.
3. Move the arrow to the desired location. Note that while the arrow is being moved the orientation of the arrow is fixed.
4. Rotate the **<Angle>** knob on the console to adjust the orientation of the arrow.
5. Press **<Set>** key to confirm the arrow and you can now enter text at the end of the arrow.

If the "**Continuous Arrow**" is checked on General Comment Settings Screen, pressing **<Set>** key will confirm the arrow and display a second arrow. Repetition of this will add multiple arrows.

Modifying comments

1. Move the cursor to a desired comment, notice that an insert cursor appears in the text as the cursor moves over an existing block of text.
2. Enter text using either the keyboard or pre-defined comments. The new comments will be added to the old text.

Deleting comments

There are several ways to delete comments:

- ◆ Move the cursor to the desired block of comments and press the **Delete** button on the touch screen to delete that block of comments.
- ◆ Press the **Delete All** button on the touch screen to remove all comments.
- ◆ Press the **<Clear>** hard key on the console to remove all comments, body marks, and measurements.

7.2 Body Mark

Body Mark allows you add a body mark graphic to an image and indicate the location of the transducer using a transducer icon on that graphic. The Body Mark function is invoked by pressing the **<Body Mark>** hard key on the console. Figure 7-2 shows an example touch screen for Body Mark. The main portion of the screen shows a grid of body marks that are pre-defined in pre-sets. See section 10 for details on how to configure these. The bottom portion of the screen shows controls available while the Body Mark function is active. Table 7-2 gives an overview of these controls.

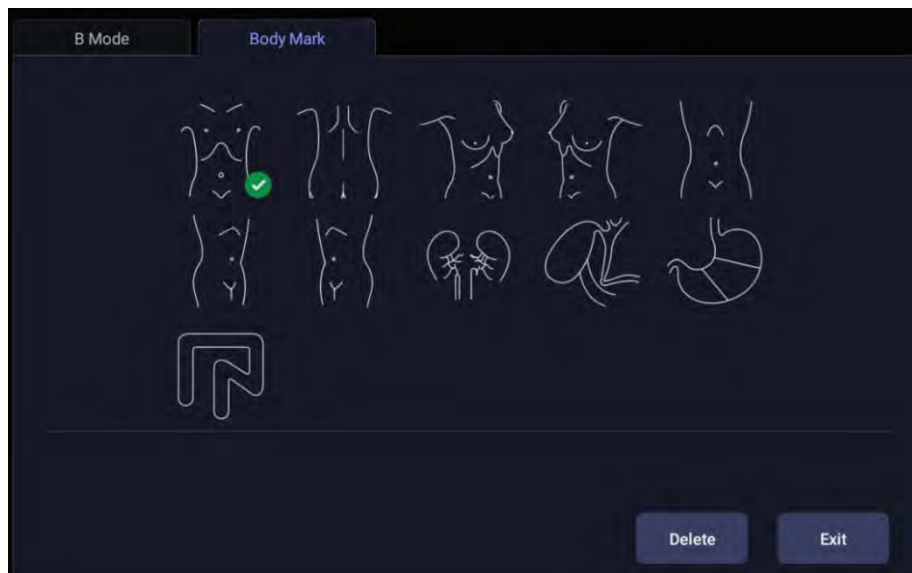


Figure 7-2 Body Mark Touch Screen

Button	Description
Delete	Delete the graphics on the image area
Exit	Press to exit the body mark function.

Table 7-2 Body Mark Touch Screen Description

Adding a body mark:

1. Invoke the **Body Mark** function.

The default body mark graphic appears on the main screen with the transducer icon shown in the default position.

2. Select a desired body mark graphic on the touch screen, that graphic replaces the default.
3. Move the position of transducer icon as needed. The orientation of the transducer icon can be changed with the **<Angle>** knob on the console.
4. Press **<Update>** key and roll the trackball to move the position of body mark graphic. The **<Update>** key can be used to toggle between moving the transducer icon and moving the body mark graphic.
5. Press **<Set>** to complete the adding of a body mark.

NOTE: In dual image or quad imaging mode, body mark can be added separately on each image.

Deleting a body mark:


There are two ways of deleting a body mark graphic:


- ◆ Press **Delete** on the touch screen to delete the graphics on the image area.
- ◆ Press the **<Clear>** hard key to delete all body marks, comments, and measurements.


7.3 Split Display

7.3.1. Dual Imaging

Dual Imaging displays images side by side on the screen. During real-time imaging when Dual imaging is enabled, the active image is displayed in real-time and the other image is frozen.

Dual image display is invoked by pressing the Dual hard key  on the console. Each single press of Dual key during real-time imaging activates the image on one side and the image on other

side becomes frozen. With both images frozen, each single press of Dual hard key  toggles between two images, but does not change the frozen status of the system.

In Dual mode, press the Single hard key  on the console to return to single image real-time scanning.

Dual Exit


Exit Dual using any of the following:

- Pressing the B, M, PW, CW hard key.
- Transducer change, preset recall, or new exam.
- Pressing the Single or Quad hard key.
- Pressing the 3D, 4D hard key

Dual image display is available in B and Color Doppler mode.

7.3.2. Quad Imaging

Quad Imaging displays images in four quadrants on the screen. During real-time imaging when Quad imaging is enabled, the active image is displayed in real-time and other images are frozen.

Quad imaging is invoked by pressing Quad hard key  on the console. Quad function button is a one-shot button. Each single press on it during real-time imaging activates one of the four images in the following order: from top left image to top right image, then to bottom left image and bottom right image. Each single press on it during frozen status switches among the four images in an order described above. but does not change the frozen status of the system.

Quad Exit


Quad is exited by any of the following:

- Pressing the B, M, PW, CW hard key.
- Pressing the Dual or Single hard key.
- Pressing the 3D, 4D hard key.
- Transducer change, preset recall, or new exam.

Color Doppler is available during Quad imaging.

7.4 Zoom

Zoom is available on the live or frozen image in B mode and Color mode. Rotate the physical **<Zoom>**

knob  on console to zoom an image.

- Zoom Knob
 - Turn the Zoom knob rightwards to make the image bigger.
 - Turn the Zoom knob leftwards to make the image smaller.

When in Zoom mode, use the trackball to pan the position of zoomed image. The B image remains zoomed after entering other imaging modes.

Full Screen Zoom:

The Full Screen Zoom function can zoom in the image to full screen display. To use Full Screen Zoom:

1. Configure the function of user-defined key **<F1>** or **<F2>** as full screen zoom(See section 11.1.1 for details).
2. Press the user-defined key **<F1>** or **<F2>** to zoom in the image area and image parameter area.
3. Press the user-defined key **<F1>** or **<F2>** again to zoom in the image area only.
4. Press the user-defined key **<F1>** or **<F2>** again to exit the full screen zoom.

7.5 Cine Review

Press **<Freeze>** key on the console to freeze the image or select a stored cine clip, and the cine bar is displayed on the bottom of the screen, as shown below.

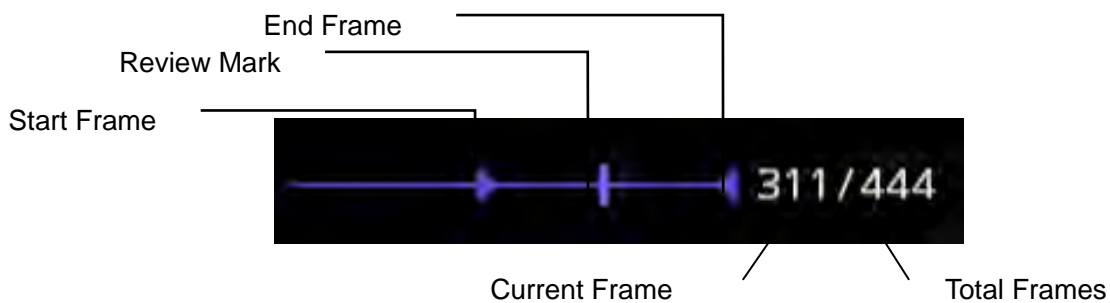


Figure 7-3 Typical Cine Bar in B/Color Mode

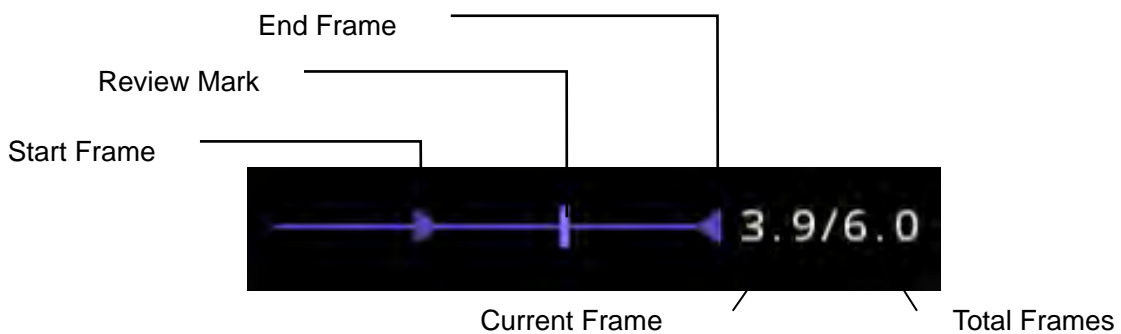


Figure 7-4 Typical Cine Bar in PW/CW/M Mode

The cine can be reviewed manually or automatically.

Manual Review:

Move the trackball to review the cine frame by frame. As the trackball moves, the current cine number is displayed on the right of the cine bar.

Auto Review:

1. Set the start frame: in manual review status move the trackball to review frame by frame until the frame that you want to set as the start point, press **Set Start** button on the touch screen to select a frame as the start frame.
2. Set the end frame: in manual review status, move the trackball to review frame by frame until the frame that you want to set as the end point, press **Set End** button on the touch screen to select a frame as the end frame.
3. Adjust the review speed by the **Speed** paddle key.
4. Press **Play** button on the touch screen to review the cine within the set region automatically.

Or,

After freezing the system, rolling the trackball rightwards quickly could play the cine automatically. When the cine is playing, moving the trackball will stop the playing.

In dual/quad imaging, freeze the image, and press quad/quad to toggle between each window. The cine bar corresponds to the currently active image, and you can perform manual/auto review for the currently active image.

8 Measurements and Reports

The Measurement function lets you perform measurements on a live or frozen image. The Generic Measurement function is invoked by pressing the <Caliper> hard key on the console, and the Application Measurement function is invoked by pressing the <Measure> hard key on the console.

Generic Measurements: These are simple tools like Distance or Area. There is no specific anatomy associated with these measurements and they do not appear in a report.

Application Measurements: These are measurements for specific anatomy or clinical conditions. The results can be entered into a report that can be printed later.

Understanding Measurement Main Screen Display

The following figure is an example of the measurements displayed on the left side of main screen. The measurements displayed on main screen varies with different imaging modes and exam presets. Here we take the measurements main screen display of B-mode Carotid preset for illustration:

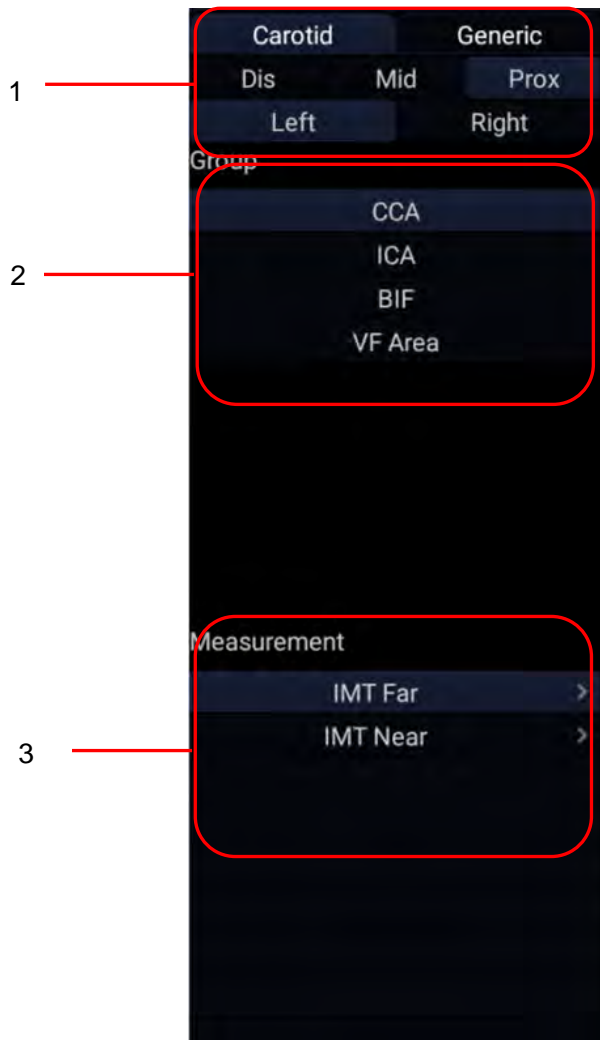


Figure 8-1 Measurement Main Screen Display

Measurement main screen display is divided into three fields:

Field 1: Displays measurement labels and attributes:

- The first line displays labels of Application Measurements and Generic Measurements. Clicking on each of them displays its associated measurement items.
- The second and third line display the attributes of Application measurement: Left, Right, Proximal, Mid, Distal, Fetus A, Fetus B, Fetus C, Fetus D, etc. For example, in Carotid exams, IMT measurements can be done for right or left carotid; in Abdomen exams, measurements can be done for right or left kidney; in Vascular exams several measurements can be done in a Proximal, Mid, or Distal location; in a twin OB exam the OB measurements can be done on either fetus.

Field 2: Displays measurement groups.

All the measurement items supported by this ultrasound system are categorized into different groups based on clinic applications, which facilitates locating the desired measurement item on the main screen and touch screen. The measurement groups vary with the current active application measurement package or generic measurements. Selecting one measurement group will show its associated measurement items below in Field 3.

Field 3: Displays measurement items.

This field displays all currently available measurement items of the selected measurement group. Select one measurement item, and then measuring operations are allowed on the ultrasound image.

Understanding Measurement Touch Screen Display

The following figure is an example of the measurement touch screen display. Here we take the application measurement touch screen display of B-mode Carotid preset for illustration. All the measurements displayed on the touch screen and main screen are consistent.

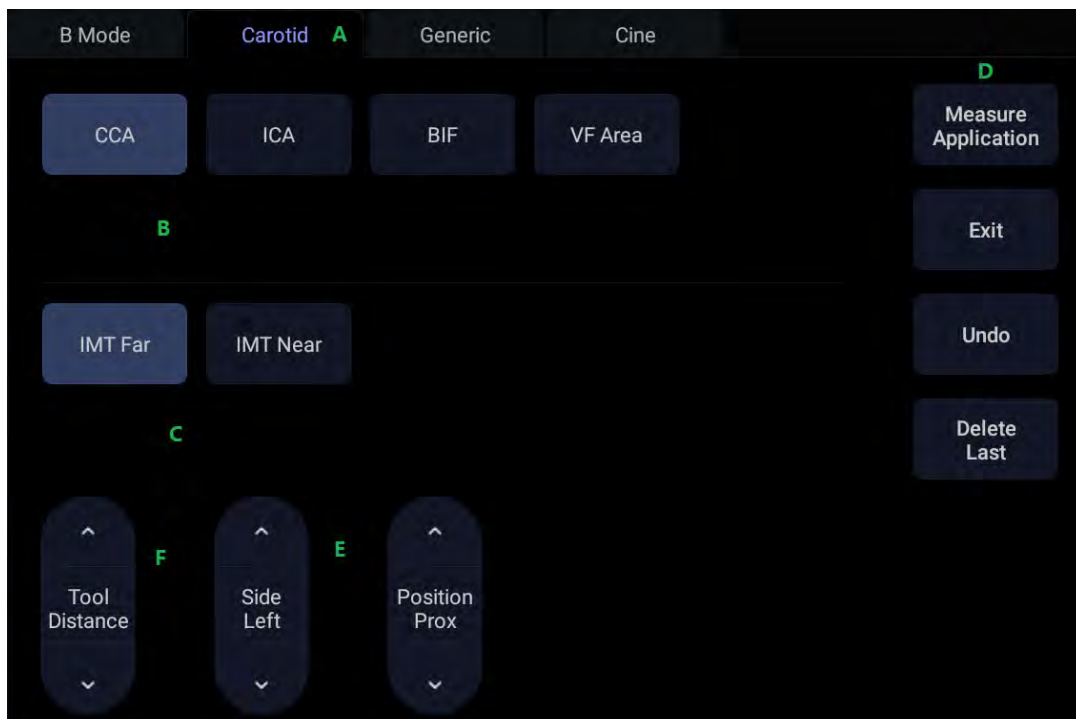


Figure 8-2 Application Measurement Touch Screen Display

No.	Name	Description	
A	Measurement label	Displays application and generic measurement labels. Pressing on any label will display its associated measurements on the touch screen.	
B	Measurement groups	Displays available measurement groups. Selecting one measurement group will show its associated measurement items below.	
C	Measurement items	Displays all available measurement items of the selected measurement group. Select one measurement item, and then measuring operations are allowed on the ultrasound image.	
D	Controls	Application Measurement	When you want to perform one measurement which is not included in current application measurement package, pressing this button will bring you all the application measurements supported on this system, and then select the desired measurement.
		Exit	Exit measurement function.
		Undo	Undo the last operation.
		Delete Last	Delete the last measurement result.
E	Measurement attributes	Displays the attributes of some application measurements, such as Left, Right, Proximal, Mid, Distal, Fetus A, Fetus B, Fetus C, Fetus D, etc. Switch these attributes by the paddle keys. These attributes are only displayed when they are applicable.	
F	Tool Options	When one measurement supports different tools, one Tool Option paddle key will display for switching tools.	

8.1 Generic Measurements

Generic measurements is invoked by pressing <**Caliper**> key on the control panel. Each imaging mode supports different types of generic measurements. This chapter describes all the generic measurements supported in each imaging mode.

8.1.1. B-mode Generic Measurements

The generic measurements supported in B-mode are listed in the table below.

No.	Measurement Group	Measurement Item	Remark
1.	Distance	Dist. 2 Point	
		Length Trace	
2.	Circ/Area	Area Ellipse	
		Area Trace	
		Area Spline	
		Stenosis% Trace	
		Stenosis% Ellipse	
		Stenosis% Spline	
3.	Angle	Angle 3 Point	
4.	Volume	Volume 3 Dist.	
		Ellipse 1 Dist.	
5.	Vessel	Vessel Diam.	2-point distance method
		Vessel Area	Ellipse method
		Stenosis% Diam.	
		Stenosis% Area	
		IMT	2-point distance method
		VF Area	2-point distance method

8.1.1.1. Distance

The distance measurement measures the distance between two points.

2-Point Method:

1. Invoke the generic measurement function.
2. Select **Distance-> Dist. 2 Point**.
3. Move the caliper to the start point.
4. Press the <**Set**> key to fix the start point.
5. Move the caliper to the end point.

Presses of the <**Update**> key will toggle between active calipers, allowing you to adjust the position of start point and end point.

6. Press the <**Set**> key to fix the end point and complete the measurement.

8.1.1.2. Circumference/Area

Circumference/Area measurement can measure the circumference and area of a closed region. There are Ellipse, Trace and Spline methods.

Ellipse Method:

1. Invoke the generic measurement function.
2. Select **Circ/Area-> Area Ellipse**.
3. Move the caliper to the start point.
4. Press the **<Set>** key to fix the start point.
5. Move the caliper and press the **<Set>** key to fix the end point. An ellipse appears and can be adjusted with the trackball.
Presses of the **<Update>** key will toggle between active calipers, allowing you to adjust the ellipse diameter.
6. Press the **<Set>** key to complete the measurement.

Trace Method:

1. Invoke the generic measurement function.
2. Select **Circ/Area-> Area Trace**.
3. Move the caliper to the start point.
4. Press the **<Set>** key to fix the start point and start drawing the trace.
5. Moving the caliper to mark the trace outline.
6. Press the **<Set>** key to complete the trace.

Spline Method:

1. Invoke the generic measurement function.
2. Select **Circ/Area-> Area Spline**.
3. Move the caliper to the desired location.
4. Press the **<Set>** key to place the first point.
5. Repeat step 3~4 to place other points. A closed trace will be created after three points are placed.
6. If a point is not placed satisfactorily, press **Undo** button to remove it. Each press of **Undo** button removes one point.
7. Double press the **<Set>** key to complete the trace.

8.1.1.3. Angle

The Angle measurement can be done by 3-point method.

3-point Method:

1. Invoke the generic measurement function.
2. Select **Angle-> Angle 3 Point**.
3. Move the caliper to the vertex of the angle you are measuring, and press the **<Set>** key to fix the first point.
4. Move the caliper to one end of the angle, and press the **<Set>** key to fix the second point.
5. Move the caliper to the other end of the angle.
Presses of the **<Update>** key will toggle between active calipers, allowing you to adjust the position of the three points that make up the angle.

6. Press the **<Set>** key to fix the third point and complete the angle measurement.

8.1.1.4. Volume

Volume can be measured with 3 Distances or 1 Ellipse+1 distance method.

3-Distance Method:

1. Invoke the generic measurement function.
2. Select **Volume-> Volume 3 Dist.**
3. Move the caliper to the start point.
4. Press the **<Set>** key to fix the start point.
5. Move the caliper to the end point.
Presses of the **<Update>** key will toggle between active calipers, allowing you to adjust the position of start point and end point.
6. Press the **<Set>** key to fix the end point and complete the measurement of the first distance.
7. Repeat step 3~6 to complete the measurements of the second and third distance. Then the Volume measurement result displays.

Ellipse+ 1 Distance Method:

1. Invoke the generic measurement function.
2. Select **Volume-> Ellipse 1 Dist.**
3. Perform one Ellipse measurement following the Ellipse method in section *8.1.1.2 Circumference/Area* measurement.
4. Perform one Distance measurement following the 2-point method in section *8.1.1.1 Distance* measurement.
5. Then the Volume measurement result displays.

8.1.1.5. Stenosis

Stenosis can be measured with Distance, Ellipse, Trace or Spline method.

Distance Method:

1. Invoke the generic measurement function.
2. Select **Distance-> Stenosis% Dist.**
3. Perform two Distance measurements following the 2-point method in section *8.1.1.1 Distance* measurement.
4. Then the Stenosis measurement result displays.

Ellipse Method:

1. Invoke the generic measurement function.
2. Select **Circ/Area-> Stenosis% Ellipse.**
3. Perform two Ellipse measurements following the Ellipse method in section *8.1.1.2 Circumference/Area* measurement.
4. Then the Stenosis measurement result displays.

Trace Method:

1. Invoke the generic measurement function.
2. Select **Circ/Area-> Stenosis% Trace.**
3. Perform two trace measurements following the Trace method in section *8.1.1.2 Circumference/Area* measurement.

4. Then the Stenosis measurement result displays.

Spline Method:

1. Invoke the generic measurement function.
2. Select **Circ/Area-> Stenosis% Spline**
3. Perform two spline measurements following the Spline method in section 8.1.1.2 *Circumference/Area* measurement.
4. Then the Stenosis measurement result displays.

8.1.2. M-mode Generic Measurements

The generic measurements supported in M-mode are listed in the table below.

No.	Measurement Group	Measurement Item	Remark
1.	Generic	Distance	2-point method
		Slope	
		Time	
		HR	

8.1.2.1. Distance

The distance measurement measures the distance between two points at the vertical direction. To measure the distance:

1. Invoke the generic measurement function.
2. Select **Dist. 2 Point**.
3. Move the caliper to the start point.
4. Press the **<Set>** key to fix the start point.
5. Move the caliper to the end point.
Presses of the **<Update>** key will toggle between active calipers, allowing you to adjust the position of start point and end point.
6. Press the **<Set>** key to fix the end point and complete the measurement.

8.1.2.2. Slope

The Slope measurement measures the distance and time between two points, and calculates the slope. To measure Slope:

1. Invoke the generic measurement function.
2. Select **Slope**.
3. Move the caliper to the start point.
4. Press the **<Set>** key to fix the start point.
5. Move the caliper to the end point.
Presses of the **<Update>** key will toggle between active calipers, allowing you to adjust the position of start point and end point.
6. Press the **<Set>** key to fix the end point and complete the measurement.

8.1.2.3. Time

The Time measurement measure the time interval between two points. To measure Time:

1. Invoke the generic measurement function.
2. Select **Time**.
3. Move the caliper to the start point.
4. Press the **<Set>** key to fix the start point.
5. Move the caliper to the end point.

Presses of the **<Update>** key will toggle between active calipers, allowing you to adjust the position of start point and end point.

6. Press the **<Set>** key to fix the end point and complete the measurement.

8.1.2.4. HR

The HR measurement measures the time interval between two points, and calculates the heart rate. To measure HR:

1. Invoke the generic measurement function.
2. Select **HR**.
3. Move the caliper to the first heartbeat.
4. Press the **<Set>** key to fix the start point.
5. Move the caliper to the next beat.

Presses of the **<Update>** key will toggle between active calipers, allowing you to adjust the position of start point and end point.

6. Press the **<Set>** key to fix the end point and complete the measurement.

8.1.3. Strip Doppler Generic Measurements

The generic measurements supported in strip Doppler mode are listed in the table below.

No.	Measurement Group	Measurement Item	Remark
1.	Generic	PS	
		ED	
		RI	
		PI	
		PS,ED,RI,S/D	
		Time	
		HR	
		Manual Trace	
		Auto Trace	
		Spline Trace	

No.	Measurement Group	Measurement Item	Remark
2.	Generic	Velocity	Only available for Cardiac exam
		Manual Trace	
		Spline Trace	
		HR	
		Time	
		PGMax	
		PGMean	
3.	Vessel	Vol. Flow	Distance + Auto Trace
4.	Tei index	COT	Only available for Cardiac exam
		ET	
5.	dp/dt	dp/dt	

8.1.3.1. Velocity

Multiple types of velocity measurements are supported on Doppler Strip, for example velocity at any point, at PS or ED.

Velocity: measures the velocity at any point on the strip, and calculates PG.

1. Invoke the generic measurement function.
2. Select **Generic-> Velocity**.
3. Move the caliper to the desired point on the strip.
4. Press the **<Set>** key to fix the point, and then Velocity and PG results display.

PS/ED: measures the velocity at PS and ED points.

1. Invoke the generic measurement function.
2. Select **Generic-> PS or ED**.
3. Move the caliper to the PS or ED point on the strip.
4. Press the **<Set>** key to fix the point, and then PS or ED result displays.

RI: measures the velocity at PS and ED points, and calculates RI result.

1. Invoke the generic measurement function.
2. Select **Generic-> RI**.
3. Move the caliper to the PS point.
4. Press the **<Set>** key to fix the PS point.
5. Move the caliper to the ED point.
Presses of the **<Update>** key will toggle between active calipers, allowing you to re-position the PS point or ED point.
6. Press the **<Set>** key to fix the ED point and complete the measurement.

S/D: measures the velocity at PS and ED points, and calculates S/D result.

1. Invoke the generic measurement function.
2. Select **Generic-> PS, ED, RI, S/D**.
3. Move the caliper to the PS point.
4. Press the **<Set>** key to fix the PS point.
5. Move the caliper to the ED point.
Presses of the **<Update>** key will toggle between active calipers, allowing you to re-position the PS point or ED point.
6. Press the **<Set>** key to fix the ED point and complete the measurement.

8.1.3.2. Trace

The Trace measurement can provide a wide range of results, as shown below. The actual results displayed will depend on Measure Setup(See section 10.4 for details).

- PS
- ED
- MD
- TAMax
- PGmax
- PGmean
- PI
- RI
- S/D
- VTI
- Time
- AT
- DT
- HR

Trace measurement is only available on a frozen strip. There are Manual Trace, Spline Trace and Auto Trace methods.

Manual Trace Method:

1. Freeze the strip and invoke the generic measurement function.
2. Select **Generic-> Manual Trace**.
3. Move the caliper to the start point.
4. Press the **<Set>** key to fix the start point and start drawing the trace.
5. Moving the caliper to mark the trace outline.
Presses of the **<Update>** key will toggle between active calipers, allowing you to adjust the positions of the PS or ED points in the trace.
6. Press the **<Set>** key to complete the trace.

Spline Trace Method:

1. Freeze the strip and invoke the generic measurement function.
2. Select **Generic-> Spline Trace**.

3. Move the caliper to the desired location.
4. Press the **<Set>** key to place the first point.
5. Repeat step 3~4 to place other points. A trace will be created after three points are placed.
6. If a point is not placed satisfactorily, press **Undo** button to remove it. Each press of **Undo** button removes one point.
7. Double press the **<Set>** key to complete the trace.

Auto Trace Method:

1. Freeze the strip and invoke the generic measurement function.
2. Select **Generic-> Auto Trace**.
3. The trace waveform(s) automatically appear, and measurement result displays.

NOTE:

1. Auto trace measurement can only be activated on a frozen Doppler strip.
2. Live Auto Trace is available as a separate feature on the Doppler touch screen. To activate Auto Trace in real time mode, press **Auto Trace** button on PW touch screen.

8.1.3.3. Time

The steps of time measurement are the same as those of time measurement in M mode. Please refer to *section 8.1.2.3* for details.

8.1.3.4. HR

The steps of HR measurement are the same as those of HR measurement in M mode. Please refer to *section 8.1.2.4* for details.

8.1.3.5. PI(Pulse Index)

PI measurement can be measured with manual trace method. To measure PI:

1. Freeze the strip and invoke the generic measurement function .
2. Select **Generic-> PI**.
3. Move the caliper to the start point.
4. Press the **<Set>** key to fix the start point and start drawing the trace.
5. Moving the caliper to mark the trace outline.

Presses of the **<Update>** key will toggle between active calipers, allowing you to adjust the positions of the PS or ED points in the trace.

6. Press the **<Set>** key to complete the trace.

8.1.3.6. Volume Flow

Volume Flow can be measured in Strip Doppler mode by the following method:

1. Freeze the strip and invoke the generic measurement function.
2. Select **Vessel-> Vol Flow**.
3. The system will first activate the measurement function on B image. Measure the vessel diameter by a 2-point distance method, and then the system traces the Doppler strip automatically. Press **<Set>** key to complete the measurement.
4. All the measured results are displayed in the measurement result window.

8.1.3.7. PG(Pressure Gradient)

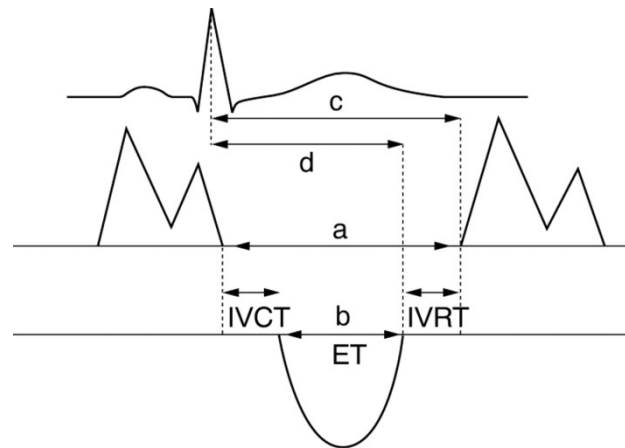
PGmax and PGmean can be measured in Cardiac exams. The measurement method is manual trace. Please refer to the steps of manual trace method in *section 8.1.3.2 trace* measurement for details.

8.1.3.8. Tei Index

The Tei index measurement is useful for the assessment of ventricular systolic and diastolic function. Higher Tei index indicates decreased ventricular function.

To use the TEI measurement:

1. In Cardiac exams, invoke the generic measurement function on a Doppler strip.
2. Select **Tei Index**.
3. Measure **COT** (Mitral Valve Close-Open Duration) by caliper pairs.
4. Measure **ET** (Ventricular Ejection Time) by caliper pairs.
5. The system calculates the Tei index automatically. The illustration is shown below:



$$\text{Index} = \frac{a - b}{b} = \frac{(\text{IVCT} + \text{IVRT})}{\text{ET}}$$

8.1.3.9. dp/dt

The left ventricular dp/dt measurement is a useful index for evaluating myocardial contractility.

To use the dp/dt measurement:

1. In Cardiac exams, invoke the generic measurement function on a Doppler strip.
2. Select **dp/dt**.
3. Move the caliper to the position at the 100 cm/s scale on one of the cardiac cycles and press the **<Set>** key.
4. Move the caliper to the position at 300 cm/s scale on the same cardiac cycle and press the **<Set>** key. The time difference "dt" between the two positions come out.
5. The system calculates dp/dt based on the "dt" value. *Formula:*

$$\text{dp/dt} = 32/\text{dt} \text{ (mmHg/s)}$$

8.2 Application Measurements

Application Measurements have a pre-defined meaning and can be entered into a report. The system supports the following application packages, each with its own set of measurements, calculations and report:

- OB (including multiple fetuses)
- Abd
- Vascular
- Cardiac
- Gynecology
- Small Parts
- Urology
- Pediatric(including Neonatal)

When you select an application measurement from the touch screen it will automatically invoke the type of measurement it needs. For example, if you select “BPD” from the OB application it will automatically invoke a distance measurement. These measurements generally behave as described above for generic measurements. The results are entered into the report when the measurement is done.

Some application measurements can have multiple variations. For example, in a twin OB exam the OB measurements can be done on either fetus. As another example, in Vascular exams several measurements can be done in a Proximal, Mid, or Distal location. When a measurement has multiple variations you will see paddle keys on the touch screen that let you pick which variation you are measuring.

Please refer to the Advanced User Manual for the calculation formulas and references.

8.2.1. Abdomen Measurements

No.	Measurement Group	Measurement Item	Description	Method
Section 1: B-mode Measurements				
1.1	Liver	Liver L	Liver Length	2-point distance in B-mode generic measurements
		Liver W	Liver Width	
		Liver H	Liver Height	
		Portal Vein	Portal Vein Diameter	
		CHD	Common Hepatic Duct	
1.2	Gall Bladder	GB L	Gallbladder Length	
		GB H	Gallbladder Height	
		GB wall th	Gallbladder wall thickness	
		CBD	Common Bile Duct	
1.3	Pancreas	Panc duct	Pancreatic duct	
		Panc head	Pancreatic head	
		Panc body	Pancreatic body	
		Panc tail	Pancreatic tail	
1.4	Spleen	Spleen L	Spleen Length	
		Spleen H	Spleen Height	
1.5	Renal	Renal L	Renal Length	
		Renal W	Renal Width	
		Renal H	Renal Height	
		Cortex	Renal Cortex thickness	
1.6	Aorta Diam		Aorta Diameter	
1.7	Bladder	Pre-BL L	Pre-void Bladder Length	
		Pre-BL W	Pre-void Bladder Width	
		Pre-BL H	Pre-void Bladder Height	
		Post-BL L	Post-void Bladder Length	
		Post-BL W	Post-void Bladder Width	
		Post-BL H	Post-void Bladder Height	
Section 2: Doppler Measurements				
2.1	AA	PS ED RI PI PS,ED,RI,S/D Time HR Auto Trace Manual Trace	Abdominal Aorta	Doppler generic measurements
2.2	SMA		Superior Mesenteric Artery	
2.3	IMA		Inferior Mesenteric Artery	
2.4	HA		Hepatic Artery	
2.5	Splenic A		Splenic Artery	
2.6	Renal A		Renal Artery	

No.	Measurement Group	Measurement Item	Description	Method
		Spline Trace		
2.7	Portal V		Portal Vein	Velocity in Doppler generic measurements
2.8	IVC		Inferior Vena Cava	
2.9	M Portal V		Main Portal Vein	
2.10	Hepatic V		Hepatic Vein	
2.11	M Hepatic V		Middle Hepatic Vein	
2.12	Splenic V		Splenic Vein	
2.13	SMV		Superior Mesenteric Vein	
2.14	IMV		Inferior Mesenteric Vein	

8.2.2. Gynecology Measurements

No.	Measurement Group	Measurement Item	Description	Method
Section 1: B-mode Measurements				
1.1	Uterus	Uterus L	Uterus Length	2-point distance in B-mode generic measurements
		Uterus W	Uterus Width	
		Uterus H	Uterus Height	
		Endo	Endometrium Thickness	
		UT-Cavity	Uterine Cavity Depth	
1.2	Cervix	Cervix L	Cervix Length	
		Cervix W	Cervix Width	
		Cervix H	Cervix Height	
1.3	Ovary	Ovary L	Ovary Length	
		Ovary W	Ovary Width	
		Ovary H	Ovary Height	
1.4	Cyst	Cyst D1	Cyst Distance 1	
		Cyst D2	Cyst Distance 2	
		Cyst D3	Cyst Distance 3	
1.5	Follicle	Fol. D1	Follicle Distance 1	
		Fol. D2	Follicle Distance 2	
		Fol. D3	Follicle Distance 3	
1.6	Fluid POD		Fluid Pouch of Douglas	

No.	Measurement Group	Measurement Item	Description	Method
Section 2: Doppler Measurements				
2.1	Ovary A	PS, ED RI PI PS,ED,RI,S/D Time HR	Ovary Artery	Doppler generic measurements
2.2	Ut. A	Auto Trace Manual Trace Spline Trace	Uterine Artery	

8.2.3. Obstetrics Measurements

Obstetric measurements are used to calculate the GA (Gestation Age), EDD (Estimated Delivery Date) and EFW (Estimated Fetus Weight).

Multiple fetuses

The Obstetric package supports measurements and reports on up to four fetuses. If you know the number of fetuses at the start of the exam then you can enter this in the Patient page (see section 4.4). When the number of fetuses is known the system adjusts the user interface to optimize for that number. If no information is entered about the number of fetuses the system will assume there is one.

No.	Measurement Group	Measurement Item	Description	Method
Section 1: B-mode Measurements				
1.1	Fetal Biometry	BPD	Biparietal Diameter	2-point distance in B-mode generic measurements
		HC	Head Circumference	Cir/Area in B-mode generic measurements
		AC	Abdominal Circumference	
		FL	Femur Length	2-point distance in B-mode generic measurements
		HUM	Humerus Length	
		OFD	Occipital Frontal Diameter	
		CER	Cerebellum Diameter	
		NF	Nuchal Fold	
		TAD	Transverse Abdominal Diameter	
		APAD	Anteroposterior Abdominal Diameter	
		THD	Thoracic Diameter	
		APTD	Anteroposterior Trunk Diameter	

No.	Measurement Group	Measurement Item	Description	Method
		TTD	Transverse Trunk Diameter	
		FTA	Fetal Trunk Area	Cir/Area in B-mode generic measurements
1.2	Early Gest	CRL	Crown Rump Length	2-point distance in B-mode generic measurements
		BPD	Biparietal Diameter	
		FL	Femur Length	
		HUM	Humerus Length	
		NT	Nuchal Translucency	
		GS*	Gestational Sac	
		YS	Yolk Sac	
		AF	Deepest Pocket	
1.3	Lone Bones	HUM	Humerus Length	
		ULNA	Ulna Length	
		RAD	Radius Length	
		TIB	Tibia Length	
		FIB	Fibula Length	
		Foot	Foot Length	
1.4	Fetal Cranium	NT	Nuchal Translucency	
		CER	Cerebellum Diameter	
		NF	Nuchal Fold	
1.5	AFI	Q1	Amniotic Fluid Index	
		Q2		
		Q3		
		Q4		
1.6	Chamber	LV Diam	Left Ventricular Diameter	
		LA Diam	Left Atrium Diameter	
		RV Diam	Right Ventricular Diameter	
		RA Diam	Right Atrium Diameter	
1.7	LVOT/AO	LVOT Diam	Left Ventricular Outflow Tract Diameter	
		Ao Asc	Ascending Aorta Diameter	
		Ao Arch	Aorta Arch Diameter	
		Ao Isthmus	Aorta Isthmus Diameter	

No.	Measurement Group	Measurement Item	Description	Method
		Desc Ao	Descending Aorta Diameter	
1.8	RVOT/PA	RVOT Diam	Right Ventricular Outflow Tract Diameter	
		MPA Diam	Main Pulmonary Artery	
		Ductus A	Duct Arteriosus Diameter	
1.9	CTAR	Area 1	Cardio/Thorax area ratio	Trace in B-mode generic measurements
		Area 2		Ellipse in B-mode generic measurements
Section 2: Doppler Measurements				
2.1	MCA	PS ED RI PI PS,ED,RI,S/D Time HR Auto Trace Manual Trace Spline Trace	Middle Cerebral Artery	Doppler generic measurements
2.2	Umb. A		Umbilical Artery	
2.3	Placenta A		Placenta Artery	
2.4	Ovary A		Ovary Artery	
2.5	Ut. A		Uterine Artery	
2.6	Fetal Ao		Fetal Aorta	
2.7	Desc Aorta		Descending Aorta	
2.8	Ductus V		Ductus Venosus	Velocity in Doppler generic measurements
2.9	FHR		Fetal Heart Rate	
2.10	MV		Mitral Valve	
2.11	TV		Tricuspid Valve	
2.12	MPV		Main Pulmonary Vein	
2.13	Ductus A		Fetal Aorta	
Section 3: M-mode Measurements				
3.1	FHR		Fetal Heart Rate	HR in M generic measurements

8.2.4. Cardiac Measurements

No.	Measurement Group	Measurement Item	Description	Method
Section 1: B-mode Measurements				
1.1	LV Simpson	A4C Dias.	Left Ventricular apical four-chamber views at End-diastole	Simpson (See section 8.2.4.1)
		A4C Sys.	Left Ventricular apical four-chamber views at End-systole	
		A2C Dias.	Left Ventricular apical two-chamber views at End-diastole	
		A2C Sys.	Left Ventricular apical two-chamber views at End-systole	
1.2	LV Study	IVSTd	Interventricular Septal Thickness at End-diastole	2-point distance in B-mode generic measurements
		LVIDd	Left Ventricular Internal Diameter at End-diastole	
		LVPWd	Left Ventricular Posterior Wall Thickness at End-diastole	
		IVSTs	Interventricular Septal Thickness at End-systole	
		LVIDs	Left Ventricular Internal Diameter at End-systole	
		LVPWs	Left Ventricular Posterior Wall Thickness at End-systole	
1.3	LV/RV	RVAWd	Right Ventricular Anterior Wall Thickness at End-diastole	2-point distance in B-mode generic measurements
		RVIDd	Right Ventricular Internal Diameter at end-diastole	
		LVIDd	Left Ventricular Internal Diameter at End-diastole	
		LVIDs	Left Ventricular Internal Diameter at End-systole	
1.4	AO	AoD	Aortic Root Diameter	
		Ao Asc	Ascending Aorta Diameter	
1.5	RVOT	RVOT Diam	Right Ventricular Outflow Tract	
1.6	LVOT	LVOT Diam	Left Ventricular Outflow Tract	

No.	Measurement Group	Measurement Item	Description	Method	
1.7	PV	PV Diam	Pulmonary Valve Diameter		
1.8	RVDs		Right Ventricular Diameter at end-systole		
1.9	LA/RA	RA Length	Right Atrium Length Diameter		
		RA Width	Right Atrium Width Diameter		
		LA Length	Left Atrium Length Diameter		
		LA Width	Left Atrium Width Diameter		
Section 2: Doppler Measurements					
2.1	Mitral Valve	E/A	E-wave Velocity/ A-wave Velocity		Doppler generic measurements
		MV PHT	Mitral Valve Pressure Half Time		
		MV Trace	Mitral Valve Trace		
		IVRT	Isovelocity Relaxation Time		
		MV A Dur	Mitral Valve A-wave Duration		
		MV DecT	Mitral Valve Deceleration Time		
2.2	Tricuspid Valve	TV Trace	Tricuspid Valve Trace		
		TV Vmax	Tricuspid Valve Maximum Velocity		
2.3	AoV(Aortic Valve)	LVOT Trace	Left ventricular outflow tract Trace		
		LVOT Vmax	Left ventricular outflow tract maximum Velocity		
		AoV Trace	Aortic Valve Trace		
		AoV Vmax	Aortic Valve maximum Velocity		
2.4	PV (Pulmonic Valve)	PV Trace	Pulmonic Valve Trace		
		PV Vmax	Pulmonic Valve maximum Velocity		
2.5	P Vein (Pulmonic Vein)	PVein S Vel	Pulmonic Veins Systole Velocity		
		PVein D Vel	Pulmonic Veins Diastole Velocity		
		PV A Vel	A Point Reverse Velocity		
2.6	HR		Heart rate	HR in Doppler generic measurements	

No.	Measurement Group	Measurement Item	Description	Method
Section 3: M-mode Measurements				
3.1	LV Study	IVSTd	Interventricular Septal Thickness at End-diastole	M-mode generic measurements
		LVIDd	Left Ventricular Internal Diameter at End-diastole	
		LVPWd	Left Ventricular Posterior Wall Thickness at End-diastole	
		IVSTs	Interventricular Septal Thickness at End-systole	
		LVIDs	Left Ventricular Internal Diameter at End-systole	
		LVPWs	Left Ventricular Posterior Wall Thickness at End-systole	
3.2	LV/RV	RVAWd	Right Ventricular Anterior Wall Thickness at End-diastole	M-mode generic measurements
		RVIDd	Right Ventricular Internal Diameter at end-diastole	
		LVIDd	Left Ventricular Internal Diameter at End-diastole	
		LVIDs	Left Ventricular Internal Diameter at End-systole	
3.3	Time	LVET	Left Ventricular Ejection Time	
		LV PEP	Left Ventricular Pre-ejection Period	
		RV PEP	Right Ventricular Pre-ejection Period	
3.4	MV(Mitral Valve)	E-F Slope	Mitral Valve E-F slope	
		EPSS	E point septal separation	
		MV D-E Exc	Mitral Valve DE Wave Amplitude	
		MV D-E Slope	Mitral Valve D-E Slope	
		MV E-E SEP	Mitral Valve E-E Separation	
		MV A-C Interval	Mitral Valve A-C Interval time	
3.5	LA/Ao	LA	Left atrial diameter	
		AoD	Aortic root diameter	
		RVOT Diam	Right Ventricular outflow tract	
3.6	HR		Heart rate	
3.7	LVM(Cube)	IVSTd	Interventricular Septal Thickness at	

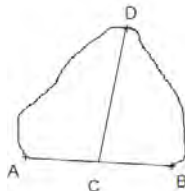
No.	Measurement Group	Measurement Item	Description	Method
	(Left Ventricular Mass)		End-diastole	
		LVIDd	Left Ventricular Internal Diameter at End-diastole	
		LVPWd	Left Ventricular Posterior Wall Thickness at End-diastole	

8.2.4.1. Simpson's Method of Disks (MOD)

Simpson's MOD is a method used to calculate LV diastolic and systolic volumes and ejection fraction. Simpson's MOD is available in the Cardiac presets.

To use the Simpson's MOD measurement:

1. Invoke the B-mode Measure function.
2. Select a measurement which could be done by Simpson's method of disks. A single caliper will be displayed on the image field.
3. Move the caliper and press <Set> key to position the start point A at one end of left ventricular long axis.
4. Draw the trace along the endocardium of the left ventricle.
5. Press <Set> key to fix the end point B and complete the trace. A new caliper positions automatically at the apex (Point D) of the trace, connecting the Point C (Midpoint of point A and B). This distance between point C and D is the longest detected by the system, as shown below:



6. Pivot the Point D caliper to a new desired position if necessary.
7. Press <Set> key to complete the measurement.

8.2.5. Small Parts Measurements

No.	Measurement Group	Measurement Item	Description	Method
Section 1: B-mode Measurements				
1.1	Thyroid	THY L	Thyroid Length	2-point distance in B-mode generic measurements
		THY W	Thyroid Width	
		THY H	Thyroid Height	
		Isthmus	Thyroid Isthmus	
1.2	Breast	Lesion 1	Breast Lesion 1	
		Lesion 2	Breast Lesion 2	
		Lesion 3	Breast Lesion 3	
		Lesion 4	Breast Lesion 4	
		Lesion 5	Breast Lesion 5	
1.3	Testis	Testis L	Testis Length	
		Testis W	Testis Width	
		Testis H	Testis Height	
Section 2: Doppler Measurements				
2.1	STA	PS ED RI PI PS,ED,RI,S/D Time HR	Superior Thyroid Artery	Doppler generic measurements
2.2	ITA	Auto Trace Manual Trace Spline Trace	Inferior Thyroid Artery	

8.2.6. Urology Measurements

No.	Measurement Group	Measurement Item	Description	Method
Section 1: B-mode Measurements				
1.1	Renal	Renal L	Renal Length	2-point distance in B-mode generic measurements
		Renal W	Renal Width	
		Renal H	Renal Height	
		Cortex	Renal Cortex thickness	
1.2	Bladder	Pre-BL L	Pre-void Bladder Length	
		Pre-BL W	Pre-void Bladder Width	
		Pre-BL H	Pre-void Bladder Height	
		Post-BL L	Post-void Bladder Length	
		Post-BL W	Post-void Bladder Width	
		Post-BL H	Post-void Bladder Height	
1.3	Prostate	Prostate L	Prostate Length	
		Prostate W	Prostate Width	
		Prostate H	Prostate Height	
1.4	Seminal	Seminal L	Seminal Length	
		Seminal W	Seminal Width	
		Seminal H	Seminal Height	
1.5	Testis	Testis L	Testis Length	
		Testis W	Testis Width	
		Testis H	Testis Height	
Section 2: Doppler Measurements				
2.1	Renal A	PS ED RI PI PS,ED,RI,S/D Time HR Auto Trace Manual Trace Spline Trace	Renal Artery	Doppler generic measurements
2.2	Arcuate A		Arcuate Artery	
2.3	Seg. A		Segmental Artery	
2.4	Int. A		Interlobar Artery	

8.2.7. Vascular Measurements

No.	Measurement Group	Measurement Item	Description	Method
Section 1: B-mode Measurements				
1.1	CCA	IMT Far	Common Carotid Artery Intima-Media Thickness (Far vessel wall)	2-point distance in B-mode generic measurements; Auto(See section 8.2.7.1).
		IMT Near	Common Carotid Artery Intima-Media Thickness (Near vessel wall)	
1.2	ICA	IMT Far	Internal Carotid Artery Intima-Media Thickness (Far vessel wall)	
		IMT Near	Internal Carotid Artery Intima-Media Thickness (Near vessel wall)	
1.3	BIF	IMT Far	Carotid Artery Bifurcation Intima-Media Thickness (Far vessel wall)	
		IMT Near	Carotid Artery Bifurcation Intima-Media Thickness (Near vessel wall)	
1.4	VF Area		Volume Flow Area	2-point distance in B-mode generic measurements
Section 2: Doppler Measurements				
2.1	CCA	PS ED RI PI PS,ED,RI,S/D Time HR Auto Trace Manual Trace Spline Trace	Common Carotid Artery	Doppler generic measurements
2.2	ECA		External Carotid Artery	
2.3	ICA		Internal Carotid Artery	
2.4	Vert A		Vert Artery	
2.5	SUBC A		Subclavian Artery	
2.6	Axill A		Axillary Artery	
2.7	Brach A		Brachial Artery	
2.8	Ulnar A		Ulnar Artery	
2.9	Radial A		Radial Artery	
2.10	CFA		Common Femoral Artery	
2.11	DFA		Deep Femoral Artery	
2.12	SFA		Superficial Femoral Artery	
2.13	CIA		Common Iliac Artery	

No.	Measurement Group	Measurement Item	Description	Method
2.14	EIA		External Iliac Artery	
2.15	IIA		Internal Iliac Artery	
2.16	Pop A		Popliteal Artery	
2.17	Peron A		Peroneal Artery	
2.18	PTA		Posterior Tibial Artery	
2.19	ATA		Anterior Tibial Artery	
2.20	DPA		Dorsalis Pedis Artery	
2.21	SUBC V		Subclavian Vein	Velocity in Doppler generic measurements
2.22	Axill V		Axillary Vein	
2.23	Brach V		Brachial Vein	
2.24	Cepha V		Cephalic Vein	
2.25	Basilic V		Basilic Vein	
2.26	Ulnar V		Ulnar Vein	
2.27	Radial V		Radial Vein	
2.28	M Cubital V		Median Cubital Vein	
2.29	CFV		Common Femoral Vein	
2.30	DFV		Deep Femoral Vein	
2.31	SFV		Superficial Femoral Vein	
2.32	CIV		Common Iliac Vein	
2.33	EIV		External Iliac Vein	
2.34	IIV		Internal Iliac Vein	
2.35	Saph V		Great Saphenous Vein	
2.36	Pop V		Popliteal Vein	
2.37	Peron V		Peroneal Vein	
2.38	PTV		Posterior Tibial Vein	
2.39	ATV		Anterior Tibial Vein	
2.40	SSV		Small Saphenous Vein	
2.41	HR		Heart Rate	HR in Doppler generic measurements
2.42	Vol Flow		Volume Flow	2-point distance+ Auto Trace

No.	Measurement Group	Measurement Item	Description	Method
2.43	ACA	PS ED RI PI PS,ED,RI,S/D Time HR Auto Trace Manual Trace Spline Trace	Anterior Cerebral Artery	Auto Trace
2.44	MCA		Middle Cerebral Artery	
2.45	PCA		Posterior Cerebral Artery	
2.46	ACoA		Anterior Communicating Artery	
2.47	PCoA		Posterior Communicating Artery	
2.48	BA		Basilar Artery	
2.49	VA		Vertebral Artery	
2.50	ICA		Internal Carotid Artery	

8.2.7.1. Auto IMT

Intima-media thickness (IMT) is a measurement of the thickness of tunica intima and tunica media. The system provides an automatic measurement of the Carotid IMT.

To measure IMT:

1. Invoke the B-mode application measurement in Carotid Preset.
2. Select an IMT measurement on the touch screen. A ROI box will be displayed on the image field.
3. Press the **Position** and **Left/Right** paddle key to select a different position of carotid artery.
4. Press <Update> key and Use the trackball to adjust the size of ROI box.
5. Press <Update> key again to confirm the size of ROI box.
6. Use the trackball to move the ROI box to desired measurement location, and then the system automatically displays the IMT measurement results.
7. Press <Set> key to complete measurement and save the results in the worksheet.
8. If you are not satisfied with the measurement result, press **Tool Options** to switch to **Distance** tool and do the IMT measurement manually.
9. The IMT measurement can display the following result:
 - Max (the maximum value of the IMT results)
 - Min (the minimum value of the IMT results)
 - Avg (the average value of the IMT results)
 - Width (the width of the ROI box)
 - SD (the Standard Deviation of the IMT results)
 - Points (the number of valid points in the IMT results)

WARNING

1. Auto IMT measurement can only be activated on a frozen image.
2. Select the Right or Left, Near or Far vessel wall, and vessel segment before generating IMT measurement, otherwise the measurement results may not be accurate.
3. Always confirm the IMT is correctly traced prior to entering the IMT result into the report.

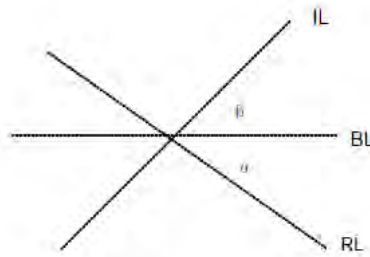
8.2.8. Pediatric Measurements

No.	Measurement Group	Measurement Item	Description	Method
Section 1: B-mode Measurements				
1.1	LLV		Left lateral ventricle	2-point distance in B-mode generic measurements
1.2	RLV		Right lateral ventricle	
1.3	LT Tri		Left trigone	
1.4	RT Tri		Right trigone	
1.5	HIP	HIP Angle	Hip joint angle	Hip Joint(See section 8.2.8.1)
		HIP d/D	Hip joint d/D ratio	

8.2.8.1. Hip Joint Measurement

Hip Joint Angle Measurement:

Hip Joint Angle Measurement is intended to evaluate the development of acetabular roof and the subluxation of femoral head for pediatrics. This measurement is performed by adding three straight lines on the anatomic image, thereby calculating two angles. See the illustration below.



- Line BL (Baseline) connects the osseous acetabular convexity to the point where the joint capsule and the perichondrium unite with the iliac bone;
- Line IL(Inclination Line) connects the osseous acetabular convexity to the labrum acetabulare;
- Line RL(Roof Line) connects the lower edge of the iliac bone to the osseous acetabular convexity.
- α is the angle between baseline and roof line.
- β is the angle between baseline and inclination line.

To use Hip Joint Angle measurement:

1. Invoke the B-mode application measurement function.
2. Select **HIP-> HIP Angle** on the touch screen and then select **Left** or **Right** on the touch screen.
3. Press the **Tool** paddle key to select the **3 Distances** or **Semi-auto** Method.

3 Distances method:

Add the baseline, roof line, and inclination line by the method of measuring distance with two points, and the system displays the results of α and β angle.

Semi-auto method:

- a. Move this horizontal straight line to place the baseline. Rotate the Angle knob on the console to adjust the angle of baseline if necessary.
- b. Press **<Set>** key and the default angle α and roof line comes out.
- c. Use the trackball to place the roof line and rotate the Angle knob to adjust the angle α .

- d. Press **<Set>** key and the default angle β and inclination line comes out.
 - e. Use the trackball to place the inclination line and rotate the Angle knob to adjust the angle β .
4. Press **<Set>** key to complete the measurement.
 5. If the age of the patient is entered, dislocation type will also be displayed in the result window. Evaluate the type of hip joint according to the Graf method, as shown in the table below.

Dislocation type		Criteria		
		α	β	Patient Age
I		$\geq 60^\circ$	$< 77^\circ$	All
II	IIa	$50^\circ - 59^\circ$	$< 77^\circ$	≤ 3 months
	IIb	$50^\circ - 59^\circ$	$< 77^\circ$	> 3 months
	IIc	$43^\circ - 49^\circ$	$\leq 77^\circ$	All
	IId	$43^\circ - 49^\circ$	$> 77^\circ$	All
III		$< 43^\circ$	$> 77^\circ$	All
IV*		The angle cannot be performed.		All
????		Others		All

Hip Joint d/D Ratio Measurement:

Hip Joint d/D Ratio measurement is intended to measure the percentage of the femoral head coverage under the iliac bone roof.

To use Hip Joint d/D Ratio measurement:

1. Invoke the B-mode Measure function.
2. Select **HIP->HIP d/D** on the touch screen and then select **Left** or **Right** on the touch screen. A single caliper will be displayed on the image field.
3. Add the baseline along the iliac bone by the method of measuring distance with two points.
4. Press **<Set>** key, and a second line displays below the baseline. Move the second line to make it be tangent to the femoral head, and the "d" distance comes out.
5. Press **<Set>** key, and a third line displays above the baseline. Move the third line to make it be tangent to the femoral head, and the "D" distance and "d/D" ratio come out.

8.3 Worksheet and Report

Worksheet is available at any time during an exam, and is displayed as default on the main screen. Report contains the information from a worksheet but it is formatted in a slightly different manner.

8.3.1. Worksheet

To view a worksheet:

Press **<Report>** key on the console to open worksheet screen. A worksheet includes: Patient Information, Measure/Calculation data and Comments.

2D Measurements		Value	V1	V2	V3	V4	Method
Liver							
Length	45.04mm	45.04					Avg. -
Width	58.11mm	58.11					Avg. -
Height	53.13mm	53.13					Avg. -
Portal V.Diam.	50.15mm	50.15					Avg. -
CHD	70.86mm	70.86					Avg. -
Gall Bladder							
Length	56.75mm	56.75					Avg. -
Height	42.00mm	42.00					Avg. -
GB wall thick	55.85mm	55.85					Avg. -
CBD	35.00mm	35.00					Avg. -
Pancreas							
Duct							-
Head							-
Body							-
Tail							-
Spleen							
Length							-

Figure 8-3 2D Worksheet Main Screen Display

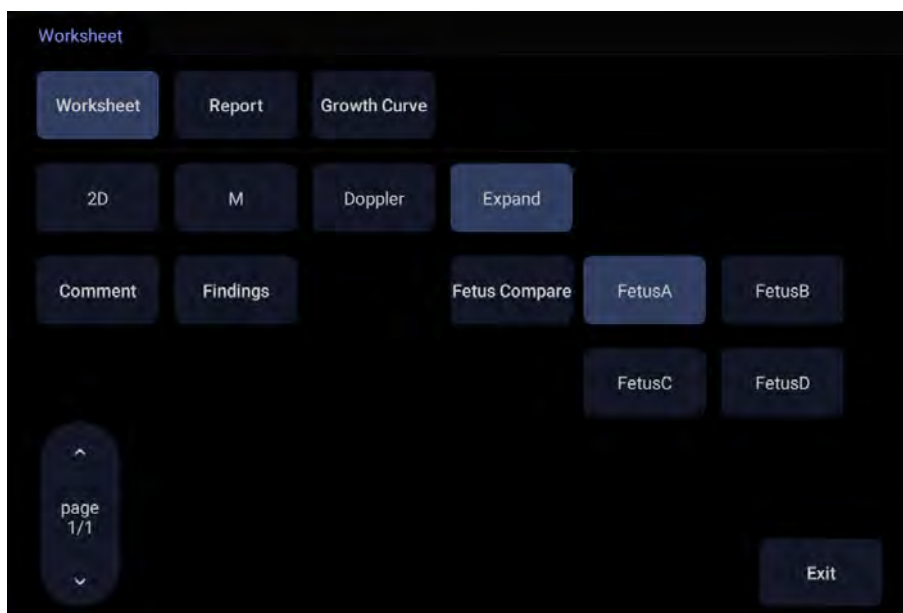


Figure 8-4 Worksheet Touch Screen Display(OB as Example)

There is a group of radio button that includes: **Report**, **Worksheet** and **Growth Curve**.

Note: Radio Buttons are buttons where only one is active at any time. Activating one will de-activate all others.

- ◆ Press **Report** button on the touch screen to get the report page.
- ◆ Press **Worksheet** button on the touch screen to switch back to the worksheet page.
- ◆ Press **Growth Curve** button on the touch screen to access the fetal growth curves. It is only available in OB worksheet, and is not displayed for any other preset. See section *8.3.3 Growth Curve* for details.
- **2D, M, Doppler**: Press these buttons to display or hide separate measurement data by image modes. The three buttons are on status as default, and user can switch it to off associated section. Each of these sections will start to display on a new page in worksheet.
- **Expand**: Press to expand and list all the measured items in B, M and Doppler modes.
- **Comment**: Press to display or hide comment section. This is an editable field for user to type any diagnosis or treatment comments.
- **Findings**: Press to display or hide the findings section. This is an editable field for user to type any ultrasound findings. See *section 8.3.4 Findings* for details.
- **Fetus Compare**: Click it to get the pages to compare multiple fetus data in one page. It only shows summary data for each fetus. It is available only in multiple fetus situations.
- **Fetus A, Fetus B, Fetus C, Fetus D**: There is a group of radio button to switch fetus, and worksheet main screen page shows data of selected fetus. It is only available in multiple fetus situations, and the number of enabled button equals current fetus number which is determined in patient information page.
- **Page**: Press to switch worksheet page in multiple pages. This is disabled when there is only one page.

To edit a worksheet:

Move the cursor over an editable field such as a measurement result, and press the **<Set>** key. A touch QWERTY is automatically invoked. Type in your changes and press the **Enter** key to save the changes. After editing a result, an "underline" will be displayed below the value to indicate this is a manually edited value.

The **Clear All** key on the worksheet page can be used to clear all the measurement results in the worksheet.

8.3.2. OB Worksheet

Please see previous section for an overview of reports and worksheets. This section describes worksheet capabilities that are unique to OB. Figure 8-7 shows an example of the OB worksheet.

Exam Date: 06/10/2000 Fetus:A/4 page:1/1

LMP A	03/10/2000	Clinical GA	13w1d	Clinical EDD C	12/15/2000
		GA(AUA) B	13w4d	EDD(AUA)	12/12/2000
FetusPos		PlacentalPos			

2D Measurements

	E AUA	Value	V1	V2	V3	V4	Method	D Reference	GA
BPD	<input checked="" type="checkbox"/>	21.81mm	22.48	21.81			Last	Hadlock	13w4d
HC	<input checked="" type="checkbox"/>	87.40mm	87.40				Last	Hadlock	13w6d
AC	<input checked="" type="checkbox"/>	68.06mm	68.06				Last	Hadlock	13w3d
FL	<input checked="" type="checkbox"/>	12.21mm	12.21				Last	Hadlock	13w4d

EFW **F** 78±11g Hadlock4(AC,BPD,FL,HC)

Figure 8-5 OB Worksheet With **Expand** on.

- A: LMP: The LMP is displayed on the first page of the report. If the LMP was entered on the Patient page that date is transferred to here.
- B: GA: Two different versions of the GA are displayed:
- Clinical GA: Calculated from the LMP.
 - GA(CUA) or GA(AUA): Displays Composite Ultrasound Age(CUA) or Average Ultrasound Age(AUA), depending the Default GA display configured in Measure Preset(see section 10.3.5 for details).
- C: EDD: Two different versions of the EDD are displayed based on the two GA values.
- D: Reference: Change the equation used to calculate the GA.
- E: CUA/AUA: These checkboxes let you decide which results are included in the CUA or AUA calculation. CUA is calculated from the selected BPD, HC, AC and/or FL measurement result; AUA is the averaged value of the selected GAs calculated from single parameter including BPD, HC, AC, FL etc. Whether CUA or AUA is displayed depends on the Default GA display configured in Measure Preset(see section 10.3.5 for details).
- F: EFW reference: Change the equation used to calculate the estimated fetal weight.

8.3.3. Growth Curve

OB Growth Curve indicates predicted fetal growth patterns according to the selected reference for a measurement or calculation. A growth curve graph can display information acquired in the current exam. Multiple fetus data can be display in the same graphic to compare their growth trending details. For each growth curve graph, there is a drop-down list for selecting specific measurement or calculation, and a drop-down list for selecting specific reference of selected measurement or calculation. Selecting one of them, the growth curve graph will change accordingly.



Figure 8-6 Growth Curve Graph

To view a growth curve graph:

Press the **<Report>** hard key to enter the Worksheet, and then press the **Growth Curve** button on the touch screen to display the Growth Curve Graph.



Figure 8-7 Growth Curve Touch Screen

Following controls are invoked by **Growth Curve** button.

- **Single/Quad:** press to select the number of the growth curve graph for display.

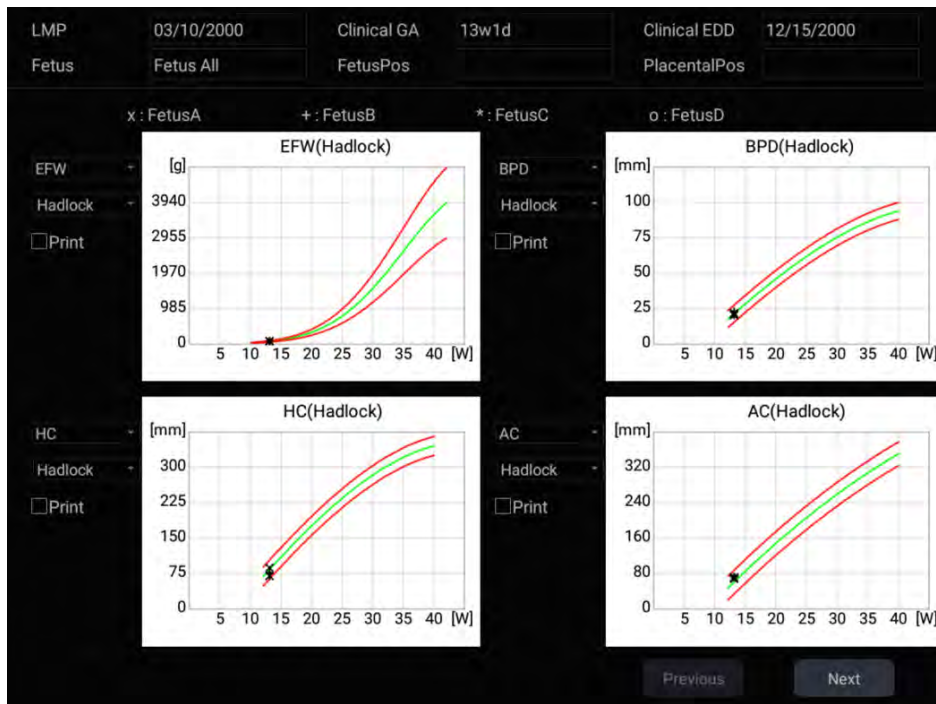


Figure 8-8 Quad Growth Curve Graph

- **Fetus Compare:** Press to display multiple fetus data in the same graphic for comparing their data directly. It appears only in multiple fetus situations, and the fetus number is determined by which is entered in patient information.



Figure 8-9 Comparing fetus in a growth curve graph

- **Fetus A, Fetus B, Fetus C, Fetus D:** There is a group of radio button to switch fetus, and the growth curve graph shows data of selected fetus. It is only available in multiple fetus situations, and the number of enabled button equals current fetus number which is determined in patient information page. It is disabled when **Fetus Compare** is on.

- **Print:** At the left side of each growth curve graphic a Print checkbox is displayed for you to determine whether to print the growth curve graphic in the report.

8.3.4. Findings

The findings user interface allows you to quickly create a paragraph of findings for the current exam. It consists of three interactions:

- Findings preset. It determines the pre-defined findings displayed. The default findings preset is auto linked to current measure preset. Click the Preset drop list and select one preset, for example ABD, then the pre-defined findings field shows all the pre-defined findings associated with ABD preset.
- Pre-defined findings. This interaction shows a list of pre-defined findings. Checking the checkbox before each findings will insert it into the editable field. This list is divided into sections, and each section can be expanded/contracted using the arrow button next to the section header.
- An editable field that displays the findings for this exam. Text can be entered directly into this field by setting the cursor in the field and using the touchscreen keyboard, or by using the library of pre-defined findings.

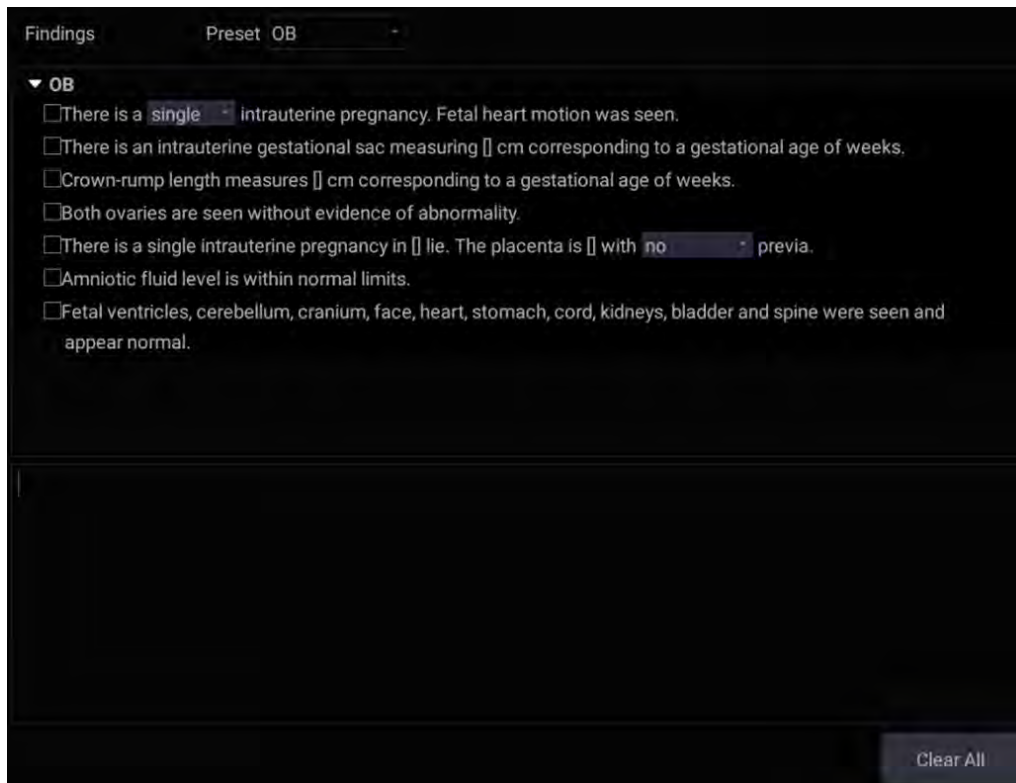


Figure 8-10 The Findings page

To customize the pre-defined findings:

1. Export the findings to a USB stick as described in section.11.3.3. The findings will be saved to the folder following the path UltraA3 Settings→ Findings.
2. Open the findings file on a PC using a text-editing program.
3. Edit the pre-defined findings. Be careful to follow the established format regarding the headers of each section and the section contents.
4. Save the file back to the USB stick. Make sure the file extension remains .xml.
5. Import the findings back into the system using the same interface described in section 11.3.3.

8.3.5. Report

Press the **<Report>** hard key to enter the Worksheet, and then press the **Report** button on the touch screen to display the Report screen. A report includes: Header, Patient Information, Images, Measurement/Calculation data, Comments and Sonographer signature .



Figure 8-11 Report Main Screen

The middle part of the main screen is the general layout of a report.

On the left side of the main screen, you can set the layout of the report:

- **Auto Adjust:** Automatically adjusts the layout of the report.
- **Image Column:** Selects the column number and the images will be displayed accordingly.

On the right side of the main screen, you can select images to add into the report.

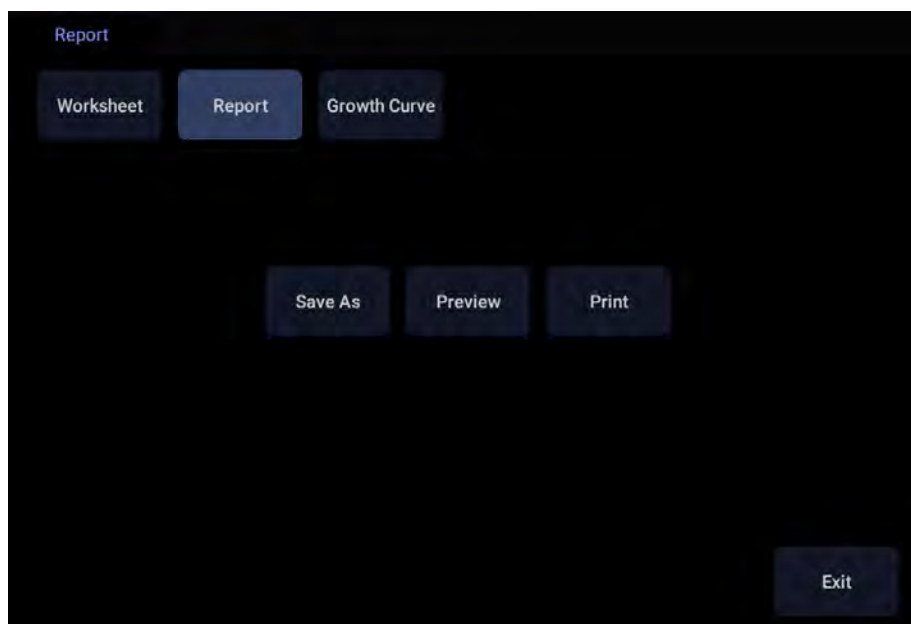


Figure 8-12 Report Touch Screen

Save As: Press it to store the report as PDF file to external storage.

Preview: Press it to invoke print preview before print. Then switching report pages and zooming in report are supported.

Print: Press it to print the report via the connected report printer.

8.4 Measurement Accuracy

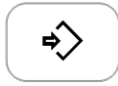
<i>Parameter</i>	<i>Range</i>	<i>Accuracy</i>
1.B Mode Measurement		
Distance	Full Screen	< ±5%
Circumference (Ellipse)	Full Screen	< ±5%
Circumference (Trace)	Full Screen	< ±5%
Area (Ellipse)	Full Screen	< ±10%
Area (Trace)	Full Screen	< ±10%
Angle	Full Screen	< ±3%
2. M Mode Measurement		
Distance	Full Screen	< ± 5%
Time	Timeline display	< ±5%
HR	Timeline display	< ±5%
3.Doppler Mode Measurement		
Velocity(PW mode)	10-200cm/s	When angle ≤60° , < ±10%
Velocity(CW mode)	10-200cm/s	When angle ≤60° , < ±10%
Time	Timeline display	< ±5%
HR	Timeline display	< ±5%

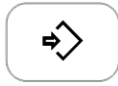
9 Exam Data Management

9.1 Storing Images

The system supports storing static images and cine clips. What is displayed in Information area, Image area and Image parameter area on the main screen will be stored.


Storing static images:



Pressing the  hard key on the console will always capture what is on the image area of the screen. This includes live, frozen, or Cine images. It also includes reports or other GUI screens and review.

Storing a clip:




Pressing the  hard key on the console will capture the moving images in scanning or cine review status.


➤ Live Store

Live store is to capture the moving images in image scanning status. The system continues scanning while storing.



The store starts with the press of the  hard key and continues for the configured length of the clip or until the clip store is interrupted. The length of the clip can be configured by setting the **Duration for prospective** on the **Store/Print** page (See section 11.1.3 for details).


The following events can cause the clip store to stop:

- A second press of  key
- Display of a GUI screen or dialog
- Mode change
- Image parameters change
- Unfreeze the image

➤ Frozen Store

Frozen store is to store the cine clip between the start frame and end frame when in cine review status.



Freeze the image and press the  hard key to start storing. The default length of the cine clip between start frame and end frame can be configured by setting the **Duration for retrospective** on the **Store/Print** page (See section 11.1.3 for details). Or, you can manually change the start frame or end frame to determine the clip length.

9.2 Reviewing Images

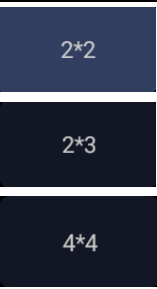
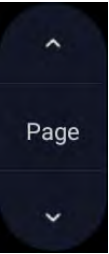
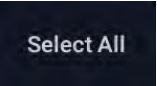
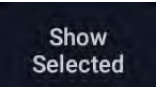
To enter image review:

If Static or Clip images have been stored for the current exam, then they can be reviewed by pressing the <Review> hard key on the console. The review touch screen is shown as the figure below.

NOTE: If nothing has been stored in the current exam, then the <Review> hard key will invoke the Exam Database function (see the next section).



Figure 9-1 Review Touch Screen

Button	Description
	Change the displayed layout: 4*4, 2*2, 2*3
	Turn pages to move forward or backward through the available images, one page at a time.
	Select all the images in the current exam.
	Toggle between showing all images and only showing the selected images.


Delete	Delete the selected image.
Export	<p>Export selected images to a removable media currently available. Plug in a USB disk, select an image, press this button and the following confirmation dialog pop-up:</p> <div style="text-align: center;">  </div> <p>Select the export path from destination drop list menu, select the export format and click OK to export.</p> <p>If there is no USB plugged in, the Export button is unavailable.</p>
Raw Data	<p>Load the raw data of the selected image or clip for post-processing. Use controls on the console or on the touch screen to do post-processing operations, such as imaging optimization, measurement, annotation, etc.</p>

Table 9-1 Review Touch Screen Controls

9.3 Exam Database

The Exam Database provides a list of recently performed studies. It can be accessed by pressing the **<Review>** hard key on the console when there is no active exam.

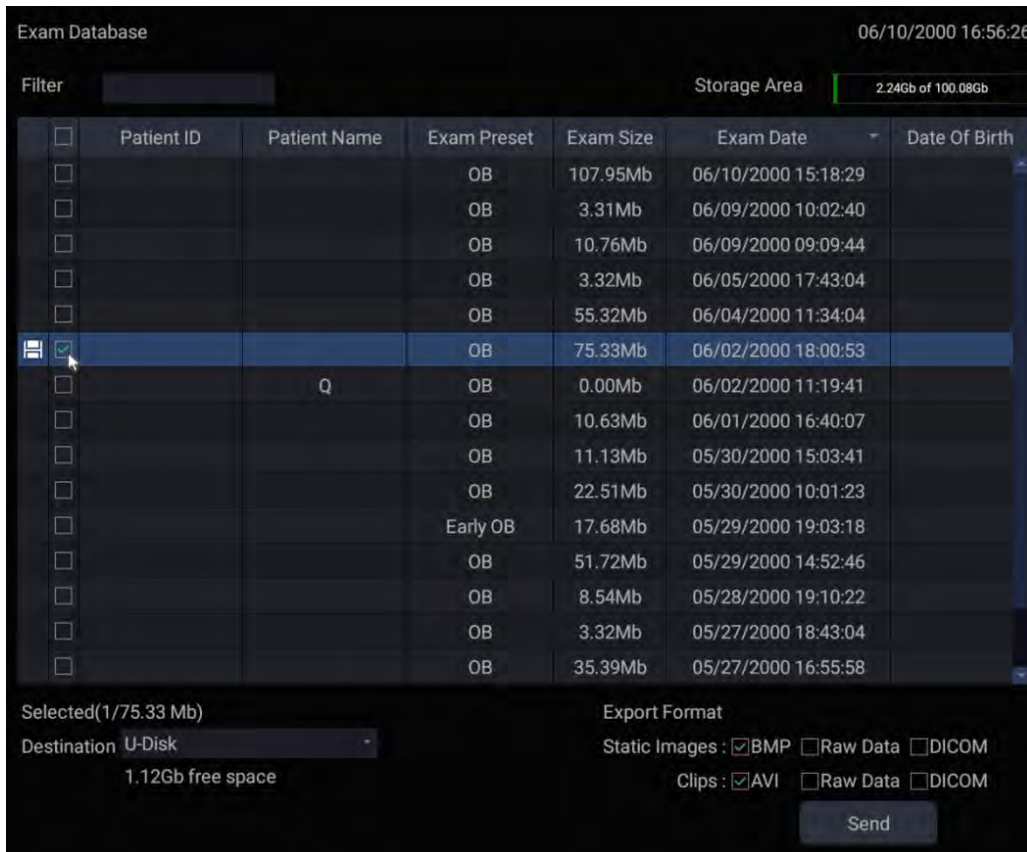


Figure 9-2 Exam Database Main Screen

The main part of the display shows a list of studies. Clicking on the header of a field will sort the list by that field. Fields can be displayed or hidden.

Filter:

The database filter field at the top-left of the screen provides a powerful tool to find the study of interest. It filters the list based on the text that is typed in this field. The filter applies to all fields. By default the filter is set to blank, so the default list shows all exams.

Storage Size:

There is a box displaying current disk usage. It contains text with the current usage and is filled with a solid color to the extent that the current capacity is used. The text shows "<current usage> of <total capacity>". The units are "Mb" for values less than 1 Gb, and "Gb" for anything larger. The solid color fill is green when usage is less than 75% of capacity, yellow for usage between 75% and 95%, and red when disk usage is above 95%.

Destination:

The location where the highlighted exam(s) shall be exported, including all configured network locations and any writable USB disk currently available. This includes:

- Available DICOM server location(s). (See 11.2.2)
- Any inserted USB disk.
- Any inserted DVD drive.

Export Format:

This location displays export format for static images and clips. BMP, Raw Data and DICOM formats are available for static images. AVI, Raw Data and DICOM formats are available for clips.

Send/Burn:

Pressing this button will send/burn the selected exam(s) to the destination. This button is available when one or more exams are selected.

Working with one study:

A study is selected by clicking on it. When a study is selected thumbnail images from that study are shown on the right side of the screen. Operations such as reviewing and restarting of the selected study can be accessed on the touch screen.

A study can also be send to a DICOM server, saved to a USB device or DVD drive, or deleted. If the study has been copied to either a server or to a USB device or DVD drive a small disk icon appears next to it, indicating that it has been saved.

CAUTION:

- Studies stored on the system hard drive should be archived regularly. The system is not intended for long term storage of patient information. Confirm successful archiving before deleting a study from the hard drive.

Working with multiple studies:

Multiple studies can be selected by clicking the small box at the left of each listed study. Multiple studies can be stored to a DICOM server, saved to a USB device or DVD drive, or deleted. Only one study can be reviewed at a time.

9.4 Archiving Studies

All Clips and Static images stored on the system are stored internally in Raw Data format. They can be archived to other storage device for long-term storage in .bmp, .avi, .dcm and Raw Data formats as described below.

- The study can be sent to a DICOM server. In this case the images are in DICOM (.dcm) format.
- The study can be saved to an USB or DVD drive. In this case the images can be stored as either DICOM, Raw Data or .bmp/.avi format.

Note:

If a clip length exceeds 3s, when selecting to export in DICOM format to DICOM server, USB stick or DVD drive, only the last 3s will be exported for this release.

Sending a study to DICOM server:

1. Configure a DICOM server. See Section 11.2.2 for details.
2. From the exam database screen, select a study or multi-studies.
3. Select a configured DICOM server from the **Destination** drop-down list.
4. Press **Send**.

Saving a study to USB or DVD

1. Plug the USB device or DVD drive into a USB port.
2. From the exam database screen, select a study or multi-studies.
3. Select the USB device or DVD drive from the **Destination** drop-down list.
4. Select the Export Formats and press **Send/Burn**.

10 Presets

10.1 Preset Organization

The Presets are divided into two levels: the Exam Presets and Application Presets.

Exam Preset. Each transducer has its own set of Exam Presets. Each Exam Preset contains:

- The image parameters that optimize its transducer for an intended use.
- Pointers to Application Presets for Comments, Measurements, Body Marks and Patient demographic data.

Application Preset. The Application Presets are independent from the transducer. Application Presets are used to select Comments, Body Marks, Measurements and Patient demographic data. Since they are independent from the transducer, several Exam Presets can use the same Application Preset.

Figure 10-1 shows an example of how Transducers, Exam Presets, and Application Presets are related. For simplicity, this shows just a few of the items that are on the real system. In this example the C5-2Q and the E8-4Q both have an OB Exam Preset. The C5-2Q OB Exam Preset optimizes the C5-2Q imaging for OB while the E8-4Q OB Exam Preset optimizes the E8-4Q for the same use. The parameters used for each transducer can be different, and changing one Exam preset does not change the other.

However, both OB Exam Presets point to the same OB Measurement Preset as the Application Preset. This means you can, for example, just configure OB measurements once, and both the C5-2Q and E8-4Q will have updated OB measurements.

This example just shows a single kind of Application Preset. The system actually has separate Application presets for Comments, Body Marks and Measurements. The same principle applies to each of these: application presets can be shared across exam presets and transducers.

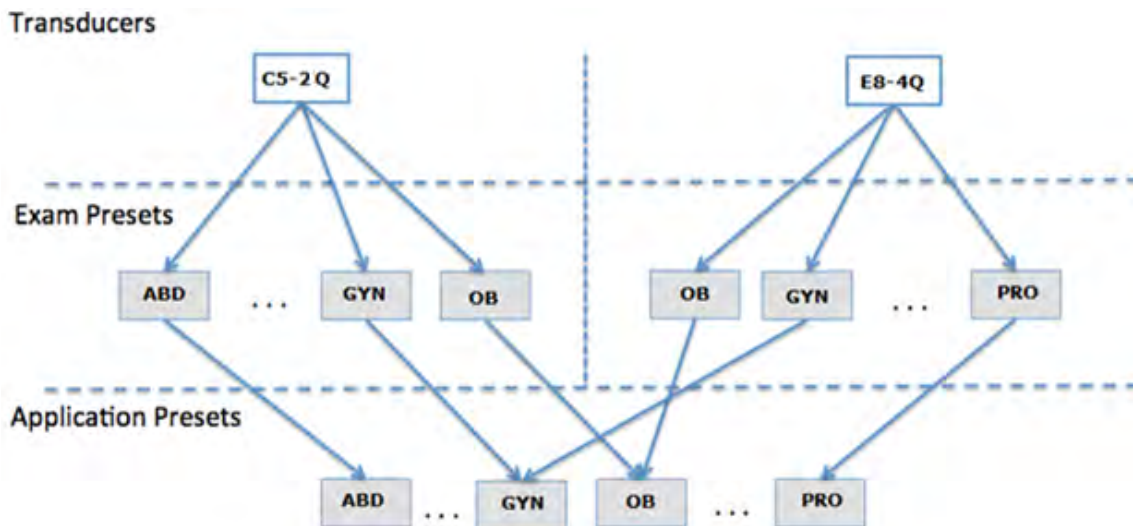


Figure 10-1 Preset Organization

10.2 Selecting a Preset

Pressing the **<Transducer>** key on the console will open the **Transducer** touch screen. See figure 10-2 for an example Transducer touch screen. The currently active transducer is shown at the top of the touch screen. Below it are all the presets associated with that transducer. Pressing any preset button selects that preset, recalling its parameters for system use.

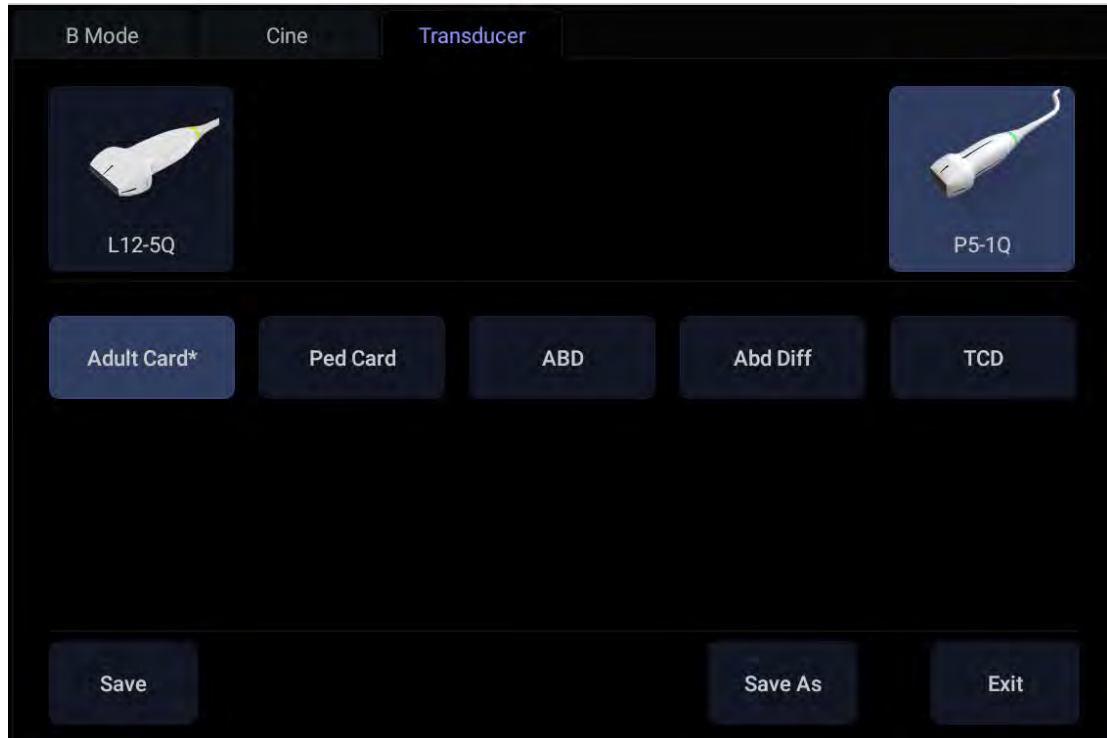


Figure 10-2 Example Preset Screen

10.3 Storing and Editing a Preset


There are two ways to store or modify an exam preset: Snapshot and Editing.

Snapshot:

- Select the exam preset you want to modify or use as the basis for a new preset.
- Make any changes you want to system settings using the standard imaging UI.
- Press the **<Transducer>** key on the console.
- Press the **Save** button on the touchscreen to update the current exam preset with the new setting.
- Press the **Save As** button to create a new preset and rename the preset.

Editing:

You can directly view and change the settings for any preset using the Set-up function.

- Click the Utility icon  on the status bar.
- Press **Presets** to display the preset touch screen, as shown below, which provides access to configuring Exam, Image, Comment, Body Mark and Measure presets. See the following sections for details.

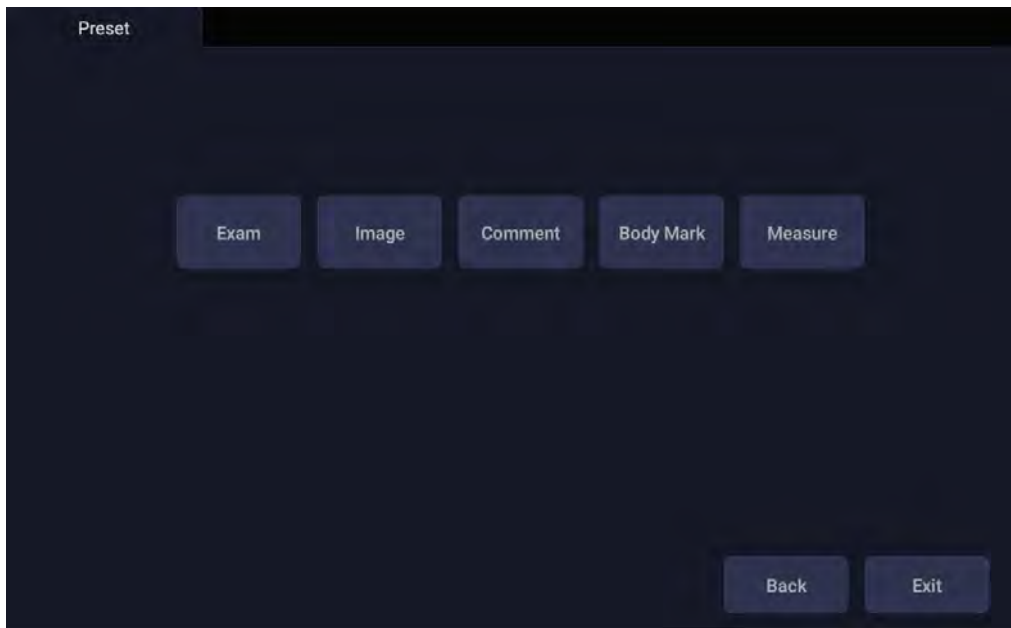


Figure 10-3 Preset Main Screen

10.3.1. Exam Preset

Figure 10-4 shows an example of the exam preset page where you can configure which Comment, Measure, Body Mark or Patient info presets are associated with each exam preset, or adjust the display order of exam presets of each transducer.

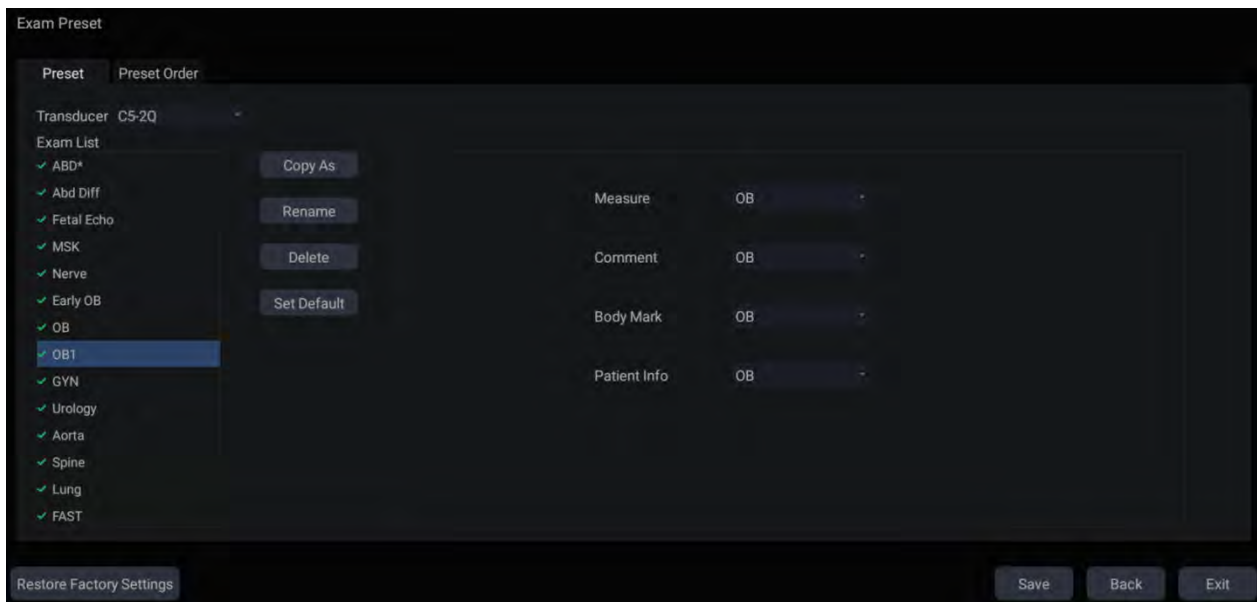


Figure 10-4 Exam Preset Page

Configure the exam presets:

- **Transducer.** Select one transducer from the list to configure its exam presets.
- **Exam List.** Select one exam preset to configure its associated Comment, Measure, Body Mark or Patient info settings.
- **Measure:** Select one of the pre-defined application measurement packages to be the default measure preset for the selected exam preset.
- **Comment.** Select one of the pre-defined comment presets to be the default comment preset for the selected exam preset.

- **Body Mark:** Select one of the pre-defined body mark presets to be the default body mark preset for the selected exam preset.
- **Patient Info:** Select one of the pre-defined patient information categories for the selected exam preset, which determines the patient information items displayed on the patient information page by default.
- **Set Default:** Set the selected exam preset as the default exam preset of the transducer. The default exam preset will be marked with "*".
- **Copy As** and **Rename:** Copy the selected exam preset as a new preset and then rename it.
- **Delete:** Delete the copied exam preset.

Adjust the display order of exam presets:

The display order of exam presets of each transducer can be adjusted on the Preset Order page, as shown below. The left part shows the transducer selection and the list of supported exam presets of the selected transducer; the right part shows the display order of exam presets, which is consistent with the display order on the **Transducer** touch screen.

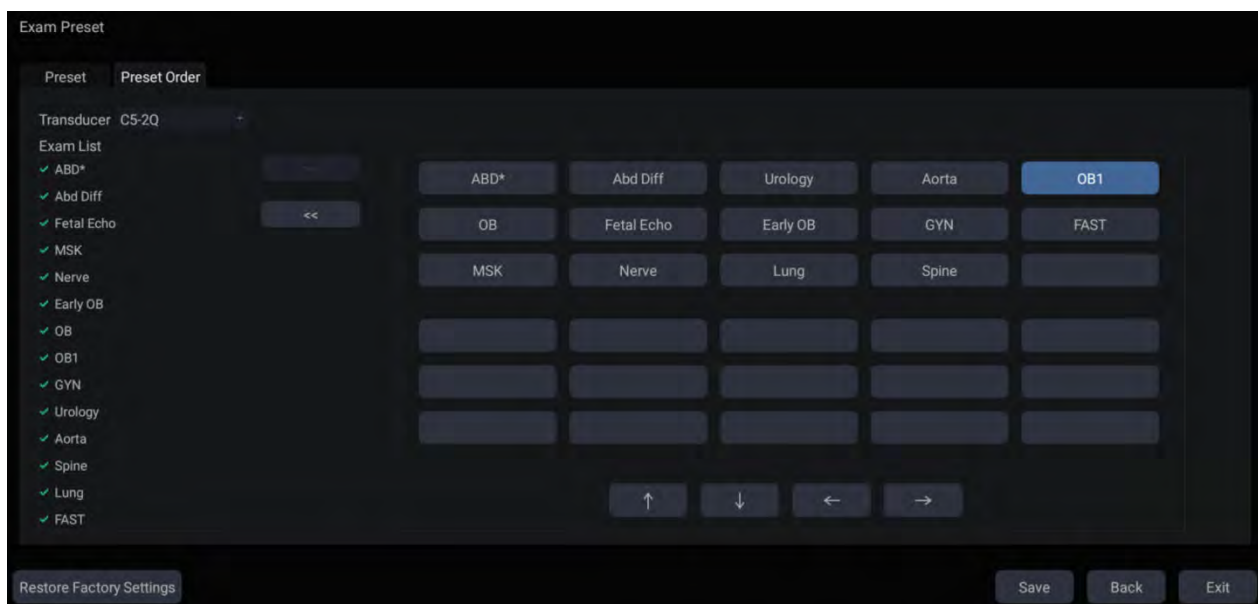


Figure 10-5 Preset Order Page

On the Preset Order page, you can do the following operations;

- Select a transducer from the Transducer drop-down list for adjusting the display order of its exam presets.
- Use the ">>" and "<<" arrows to determine which exam presets will be displayed.
- Select one exam preset, and use "↑", "↓", "←" and "→" arrows to adjust its display order.

10.3.2. Image Preset

Figure 10-6 shows an example set-up screen for Image Preset, where you can configure the imaging parameters for an exam preset. This example shows the screen for editing the B-mode settings for the C5-2Q OB exam preset.



Figure 10-6 Example Set-up Screen for Image Preset

Transducer and **Exam**: There are drop-downs at the top of the screen for selecting the Transducer and Exam Preset you want to edit. Each transducer has its own set of exam presets, and these two drop-downs let you select which exam preset, on which transducer, you want to edit.

TI: Select the TIB, TIS or TIC to display on main screen.

Power: Set the default acoustic output power of the current exam preset.

Image Modes: The next row of controls show tabs for each imaging mode. These let you select which imaging mode you want to edit for the current exam preset. The example shows the B-mode tab selected.

The image mode is divided into two sections. Parameters that have one value for each preset are shown on the left. Parameters that are associated with Image Types are shown on the right.

Image Type: Each imaging mode has a set of image types. For example in B-mode the types are Detail, General, and Penetration. While imaging, the image type lets you quickly change the aesthetic look of the image without changing settings like depth or invert status. The right side of the preset set-up screen shows a tab for each image look. The parameters shown below those tabs let you customize that image type for the current preset.

Restore Factory Settings: Restore the image preset of the current exam preset of the selected transducer to the factory default settings.

Restore All Factory Settings: Restore the image presets of all exam presets of all transducers to the factory default settings.

10.3.3. Comment Preset

Figure 10-7 shows an example set-up screen for Comment Preset, where you can add or edit the comment texts of each Comment preset.

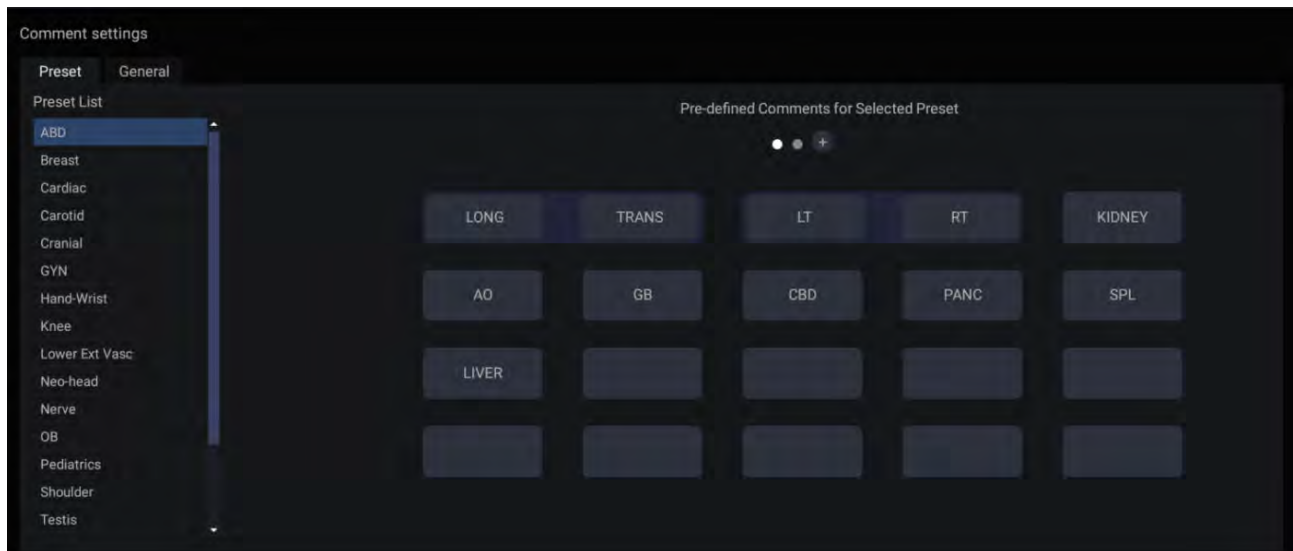


Figure 10-7 Comment Preset Screen

Editing Comment Preset:

Select a comment preset from the preset list on the left side of the screen, and then you can do the followings to edit the comment texts for the selected preset.

➤ **Adding a new Comment:**

1. Move the cursor to a blank block and press **<Set>**.
2. Enter a new comment through keyboard.

➤ **Editing an Exist Comment in Comment Preset:**

1. Move the cursor to a comment and press **<Set>**.
2. Edit the selected comment through keyboard.

➤ **Deleting an Exist Comment in Comment Preset:**

1. Move the cursor to a comment and press **<Set>**.
2. Press **Delete** key on the keyboard to delete the selected comment.

General Settings:

- **Auto-erase comments when the image is unfrozen:** If this option is enabled, the comments will be erased when the image is unfrozen, otherwise the comments will only be erased on demand or at the start of a new exam.
- **Continuous Arrow:** If this option is enabled, you can add multiple arrows continuously by pressing **<Set>** key after **Arrow** touch button is enabled in Comment function. If this option is disabled, only one arrow can be added after **Arrow** touch button is enabled. A second arrow is added by pressing **Arrow** touch button again.
- **English Comments Library:** If this option is enabled, the system will use the comments library in English when the system language is not English.

10.3.4. Body Mark Preset

Figure 10-8 shows an example set-up screen for Body Mark Preset, where you can configure which body mark graphics appear with each Body Mark preset.

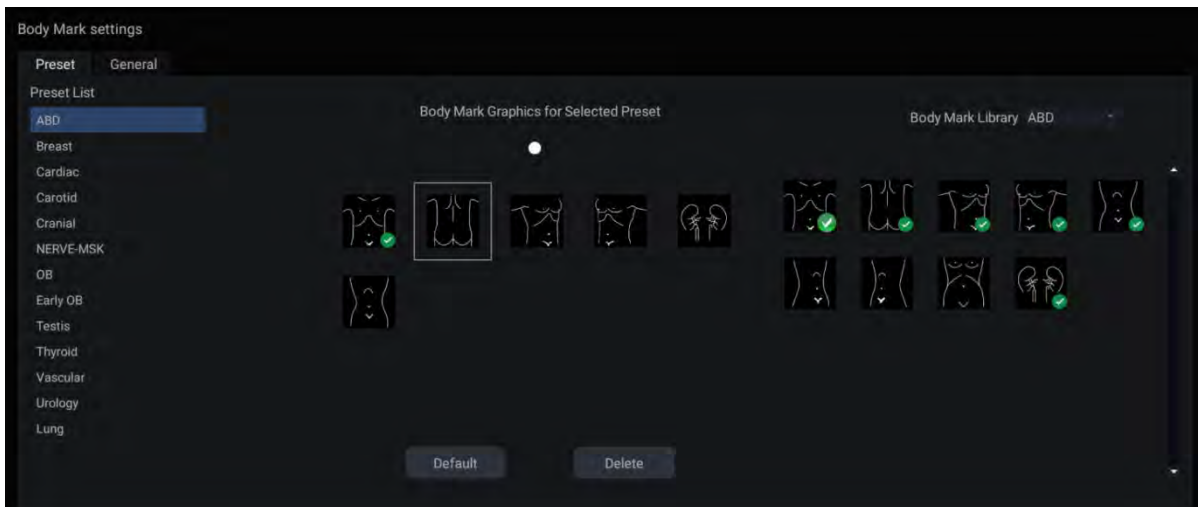


Figure 10-8 Body Mark Preset Screen

Editing Body Mark Preset:

Select an Body Mark preset from the preset list on the left side of the screen, and then you can do the followings to edit the body mark preset for the selected preset.

➤ **Adding a Body Mark to a Preset:**

The right of the screen provides Body Mark Library. Select one domain of Body Mark from the drop-down list, for example ABD, and its body mark graphics are displayed in the box beneath.

Move the cursor to a Body Mark in the Body Mark Library box on the right side of the screen and press **<Set>**. When a Body Mark graphic is added to the box on the middle of the screen which displays the pre-defined body mark graphics for the select preset, it is marked with a green check mark in the Body Mark Library box. When more than one page of Body Mark graphics are added to the middle box, the system will create another new page, indicating by dots at the top of the box. Clicking the dots switches the page.

➤ **Deleting a Body Mark from a Preset:**

Move the cursor to a Body Mark graphic in the middle box and press **<Set>**. Press the **Delete** button below the box to delete it.

Or, move the cursor to a Body Mark graphic with green check mark on it and press **<Set>** to delete it from the selected preset.

➤ **Setting a Default Body Mark for a Preset:**

Select a Body Mark from the box of Body Mark Graphics for Selected Preset and Press **Default**. The Body Mark graphic is set as the default Body Mark to the selected preset.

The default Body Mark can not be deleted from a preset until another Body Mark is selected as a default one.

General Settings:

- **Auto-erase body mark when the image is unfrozen:** If this option is enabled, the body mark will be erased when the image is unfrozen, otherwise the body mark will only be erased on demand or at the start of a new exam.

10.3.5. Measure Preset

10.3.5.1. General Set-up

Figure 10-9 shows an example set-up screen for Measure Preset, where you can configure general measurement settings.

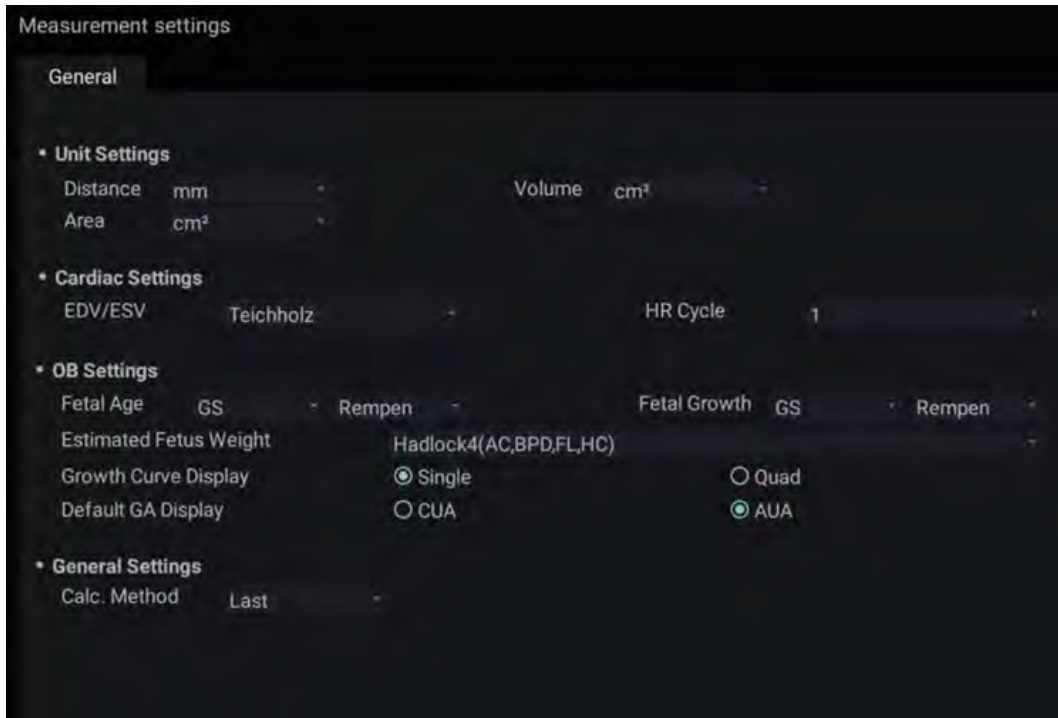


Figure 10-9 Measure Preset Screen

- **Unit Settings**

The system supports following unit settings:

- **Distance:** Set the default unit of distance measurement. "mm" and "cm" are available.
- **Area:** Set the default unit of area measurement. "mm²" and "cm²" are available.
- **Volume:** Set the default unit of volume measurement. "mm³" and "cm³" are available.

- **Cardiac Settings**

The system supports following Cardiac measurement settings:

- **EDV/ESV:** set the author of the formula that is used in EDV/ESV calculation. There are three options: Teichholz, Gibson and Cube.
- **HR Cycle:** set the number of heartbeats that are assumed in the HR or FHR measurement calculation. Range: 1-8.

- **OB Settings**

The system supports the following OB measurement settings:

- **Fetal Age:** set equation for measurements which are used for calculating fetal age.
- **Fetal Growth:** set equation for measurements which are used for calculating fetal growth.
- **Estimated Fetus Weight:** select an equation for the Estimated Fetus Weight calculation.
- **Growth Curves Display:** set single or quad curves as the default display format for the Growth Curves.
- **Default GA display:** set the CUA (Composite Ultrasound Age) or AUA (Average Ultrasound Age) as a default result displayed in the worksheet.

- **General Settings:**

- **Calc. Method:** set the calculation method for the finally displayed result in the report when multiple times of measurement operation were done for one measurement item. Available methods include Last, Average, Max. and Min..

10.3.5.2. Application Parameters

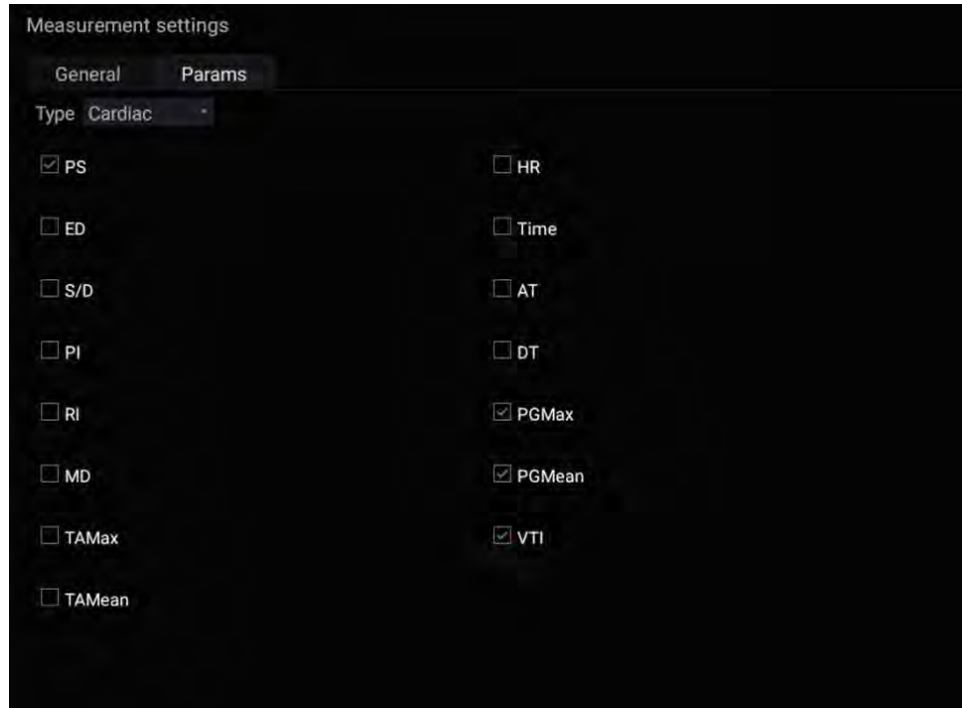


Figure 10-10 Application Parameter Set-up Screen

On the **Application Parameter** page, you can configure the default measurement results of Doppler trace measurement for each exam application. Select one clinic application in the **Application** drop-down list, for example ABD, and then tick the measurement result items in the list below. When you perform Doppler trace measurement, the system will display all the ticked result items by default

11 Utilities

To open the **Utility** screen:

1. Press **<Cursor>** key to display the cursor;



2. Move the cursor to the Utility icon displayed at the lower left corner of the screen;
3. Press **<Set>** key.

The **Utility** screen provides access to System setup, Presets, Connectivity, Maintenance and Screen adjust. Each of these is described in separate sections.

11.1 System Set-up

System setup is used to configure parameters that are unrelated to presets. Generally, there is one value of each system setup parameter that is shared across all presets.

Entering System Set-up:

Open **Utility** screen. Press **Set up** touch screen button, and then the **System** touch screen button to access system setup.

Reloading Factory Default Settings:

1. Press "Restore Factory Settings" on the System Settings screen, you are prompted "Restore System Setting to factory default? This will erase all system data."
2. Press **Yes** to restore to factory default, and press **No** to cancel.

11.1.1. General Set-up

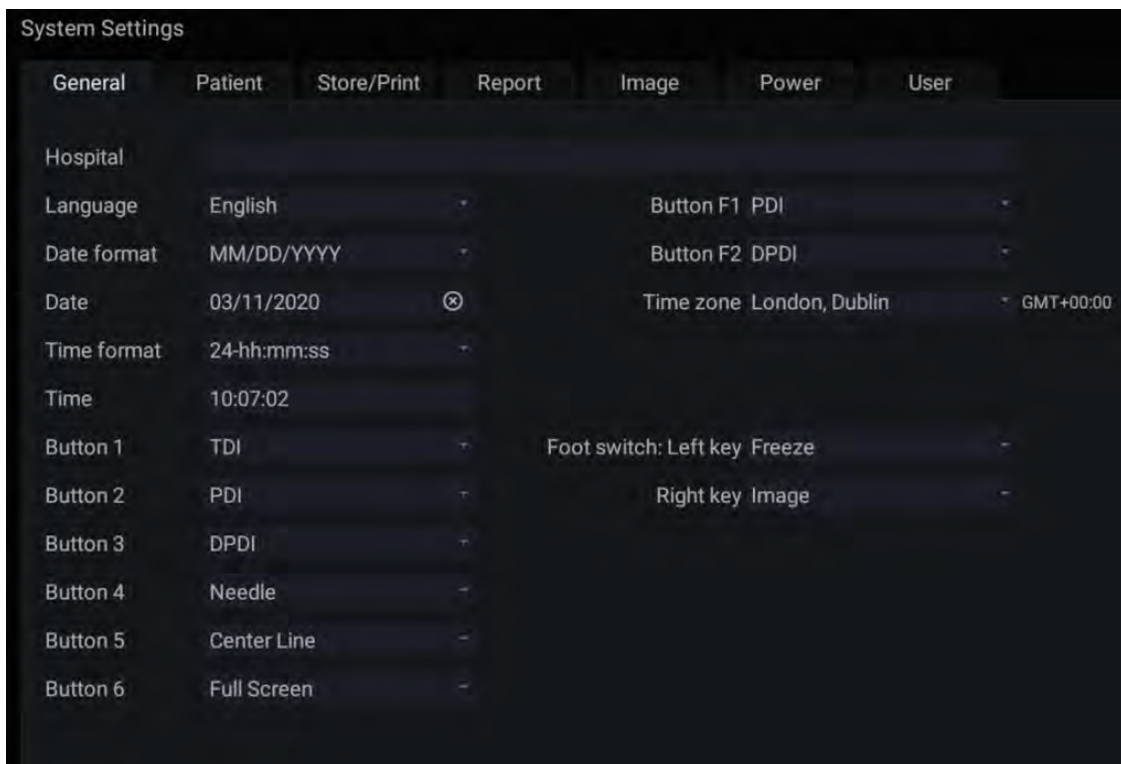


Figure 11-1 General Set-up Screen

Item	Options	Description
Hospital	Input freely	Set hospital name displayed on the top left of the screen and diagnosis report.
Language	Chinese, English, etc	Set the system language(new language is effective after reboot the system).
Date Format	YYYY/MM/DD/ MM/DD/YYYY DD/MM/YYYY	Set the date format.
Date	/	Set the system date Note: If the license is invalidated because of changing the system date, please contact EDAN serviceman.
Time Format	12-AM/PM, 24-hh:mm:ss	Set the time format.
Time	/	Set the system time, format: H/M/S.
Button 1 Button 2 Button 3 Button 4 Button 5 Button 6	PDI, DPDI, TDI, Needle, Center Line, Full Screen, eLearn.	Set a function for the five shortcut keys on the left of the touch screen. The options that are available will depend on what functions are enabled on the system.
Button F1/F2		Define the F1/F2 keys, select one of the pull-down options. The options that are available will depend on what functions are enabled on the system.
Time Zone	/	Select the time zone from the drop down list.
Video Mode	PAL/NTSC	Set the output video mode. The selected video mode should be the same as that of the s-video printer, otherwise the printer can not work.
FootSwitch	Freeze, Image, Clip, Print	Set a function for the left key or right key of Footswitch. If the physical footswitch only has one button then the Left button selection applies.

Table 11-1 General Set-up Description

11.1.2. Patient Set-up

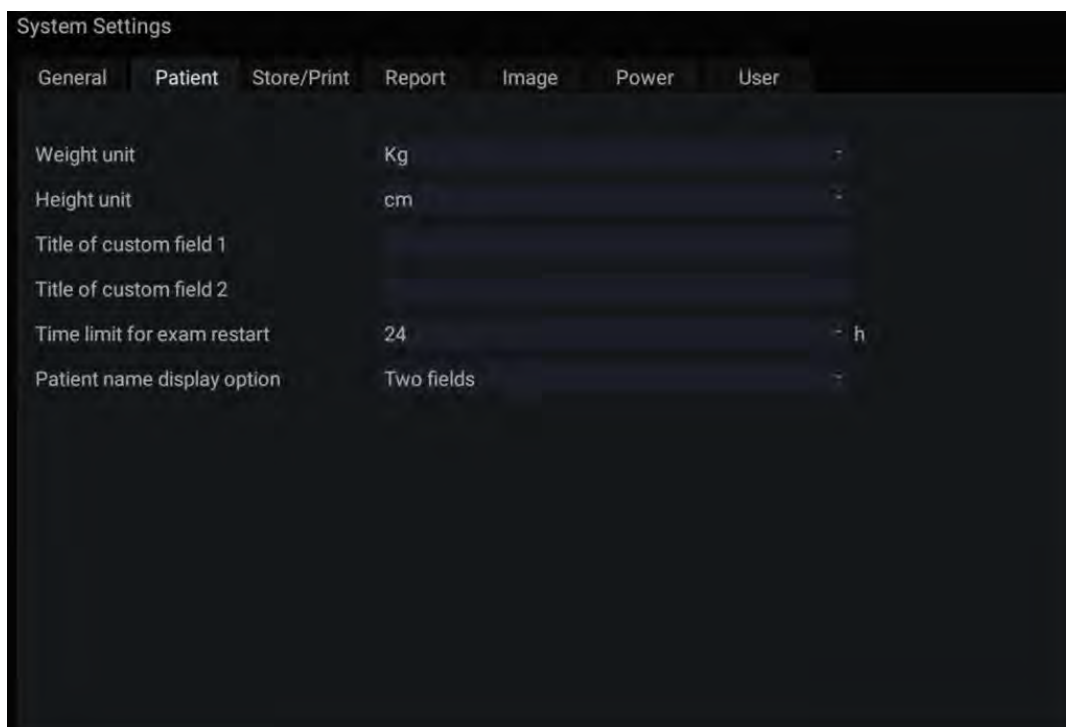


Figure 11-2 Patient Set-up Screen

Item	Options	Description
Weight Unit	kg, lbs	Set the weight unit of patients
Height Unit	cm, ft/in	Set the height unit of patients
Title of custom field 1/2	/	You can define two additional fields for data entry on the Patient Information screen. The Patient Information screen only displays the data entry when you define the title of the custom field.
Time limit for exam restart	0/12h/24h/48h/72h/Unlimited	You can define the time limit for restarting exam. Only exams within the time limit can be restart. If 0 is selected, no exam can be restart.
Patient name display option	One field/Two fields	You can define the patient name display format. The patient information page displays “Patient Name” for one field and displays “Last Name” and “First Name” for two fields.
Clinical EDD	40 Weeks, 41Weeks	Select one item to calculate the clinical EDD.
Clinical GA	LMP, BTT	Select one item to calculate the clinical GA.

Table 11-2 Patient Set-up Description

11.1.3. Store/Print Set-up

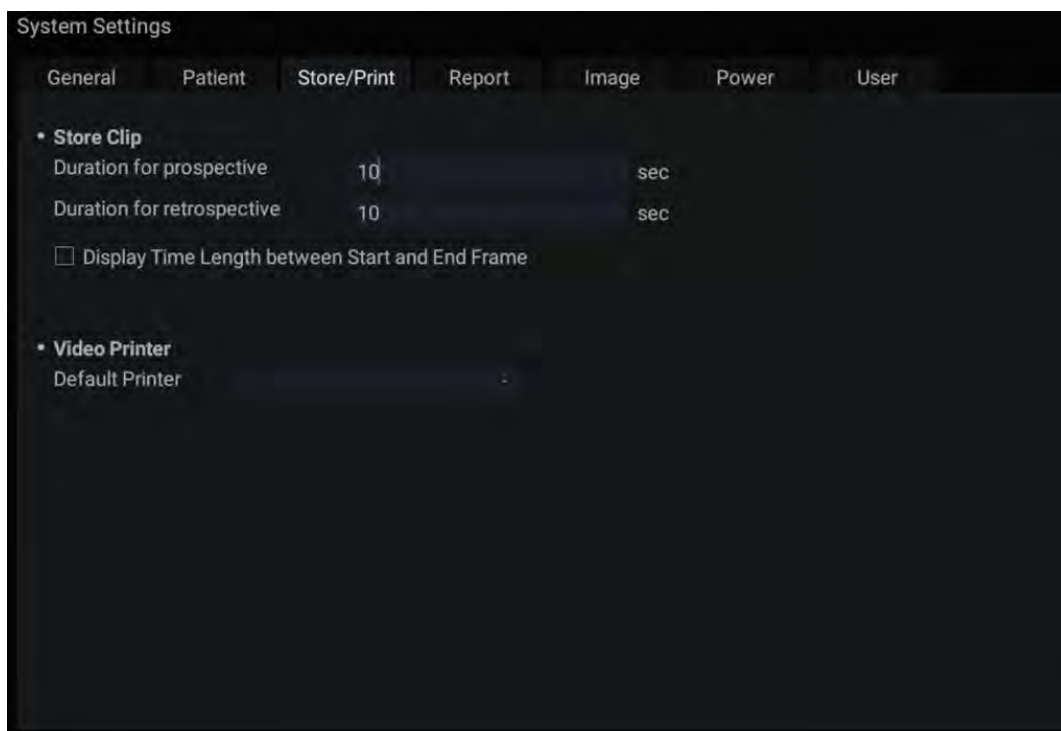


Figure 11-3 Store/Print Set-up Screen

<i>Item</i>		<i>Description</i>
Store Clip	Duration for prospective	Set the cine length for prospective cine storing in live scanning status.
	Duration for retrospective	Set the default cine length for retrospective cine storing in the frozen status.
	Display Time Length between Start and End Frame	Set whether to display the time length between the start frame and end frame on the cine bar. The time length display is helpful for knowing the cine length when storing a clip in the frozen status.
Video Printer	SONY-UP-D25MD, SONY-UP_X898MD MITSUBISHI_P95D	Select one video printer as the default printer from the list when more than one video printer are connected with the system via USB cable.

Table 11-3 Store/Print Set-up Description

11.1.4. Report Set-up

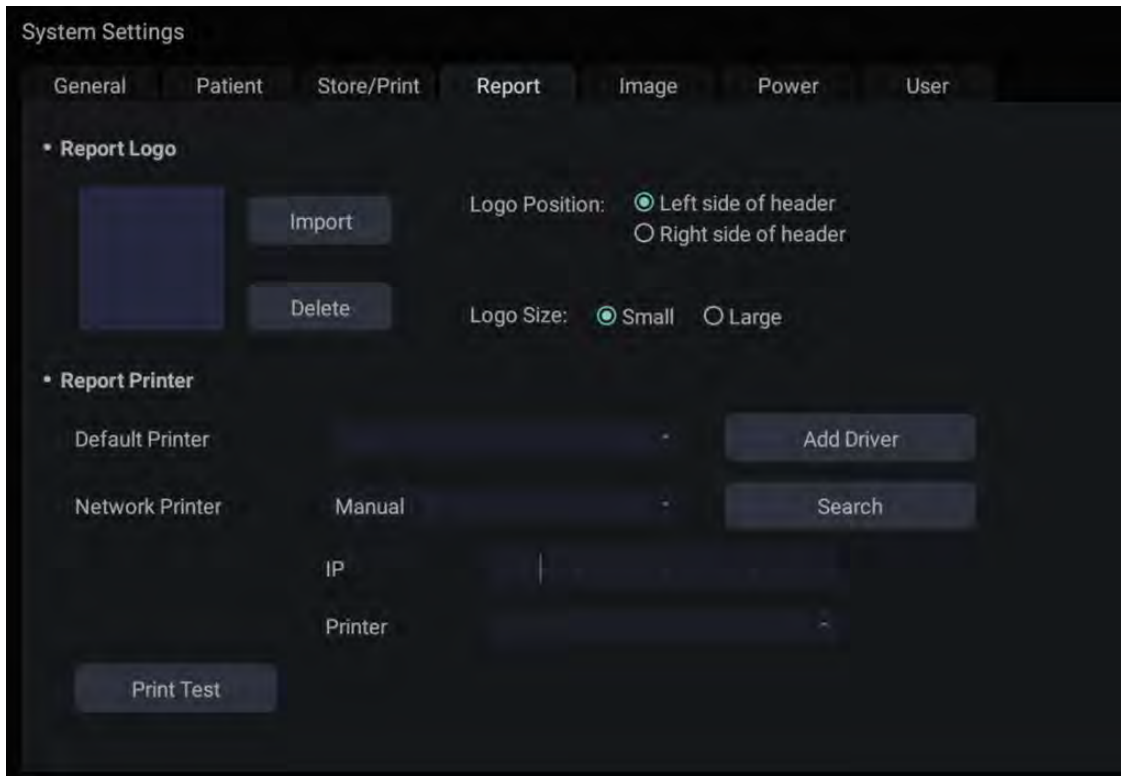


Figure 11-4 Report Set-up Screen

<i>Item</i>		<i>Description</i>
Report Logo	Import	Import a bmp format logo from USB disk.
	Logo Position	Set the logo position to locating at the left or right side of report header.
	Logo Size	Set the logo size to Small or Large.
	Delete	Delete the imported logo.
Report Printer	Default Printer	Select one report printer as the default printer from the list when more than one report printer are connected with the system.
	Add Driver	Multiple printer drivers were included in this system. If the driver of your printer is not included, the driver files provided by the manufacturer can be imported from the USB stick to this system via the Add Driver button.
	Network Printer	Network printers can be connected with Auto and Manual method. Note: TCP/IP network settings should be configured for this system prior to connecting network printers. Auto: press the Search button to search the available network printers in the same network, and select the printers from the list to connect. Manual: enter the IP address of the network printer, select the printer model name from the Printer

		drop-down list, and then press the Search button to search the network printer. Select the printer from the search result to connect.
	Print Test	Print the test page to check whether the printer is connected successfully.

Table 11-4 Report Set-up Description

11.1.5. Image Set-up

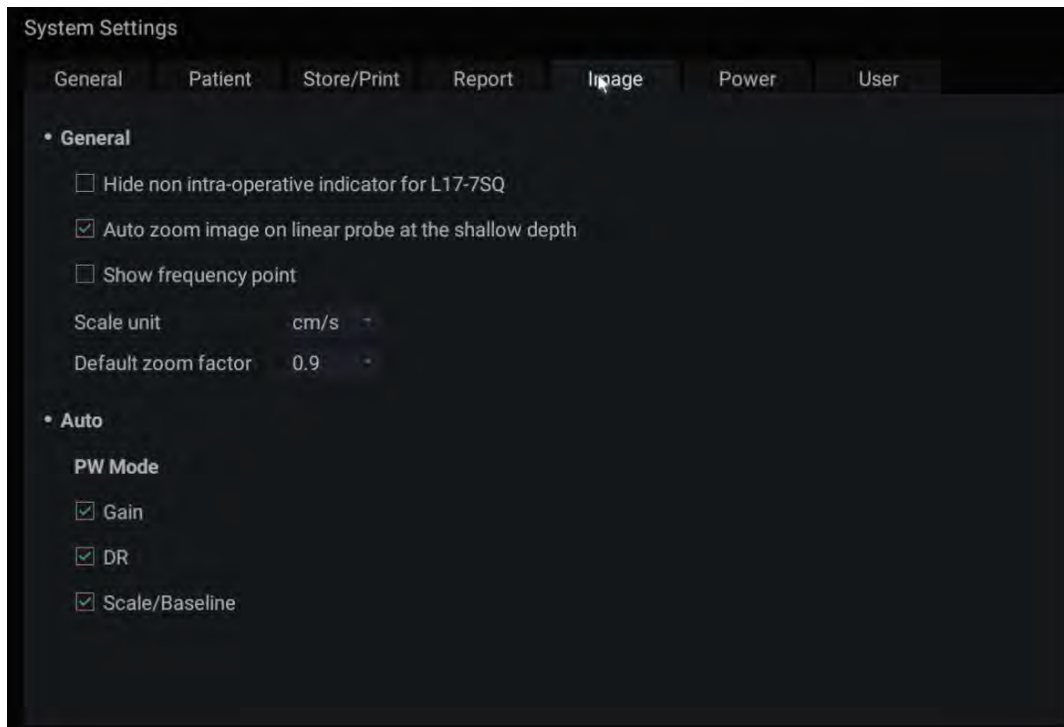


Figure 11-5 Image Set-up Screen

Item	Options	Description
Hide non intra-operative indicator for L17-7SQ	√/x	Set whether to hide the hint of “non intra-operative” while using transducer L17-7SQ.
Auto zoom image on linear probe at the shallow depth	√/x	Set whether to auto zoom image at the shallow depth when using linear transducers.
Show frequency point	√/x	Set whether the frequency of transducers is displayed in the format of frequency point.
Scale unit	cm/s, kHz	Set the velocity units of spectrum scale.
Default zoom factor	0.8-2.0	Set the default zoom factor of the image area.

PW Mode	Gain	√/x	Optimize Gain or not when press Auto button on the control panel in PW mode.
	DR	√/x	Optimize Dynamic Range or not when press Auto button on the control panel in PW mode.
	Scale /Baseline	√/x	Optimize Scale/Baseline or not when press Auto button on the control panel in PW mode.

Table 11-5 Image Set-up Description

11.1.6. Power Set-up

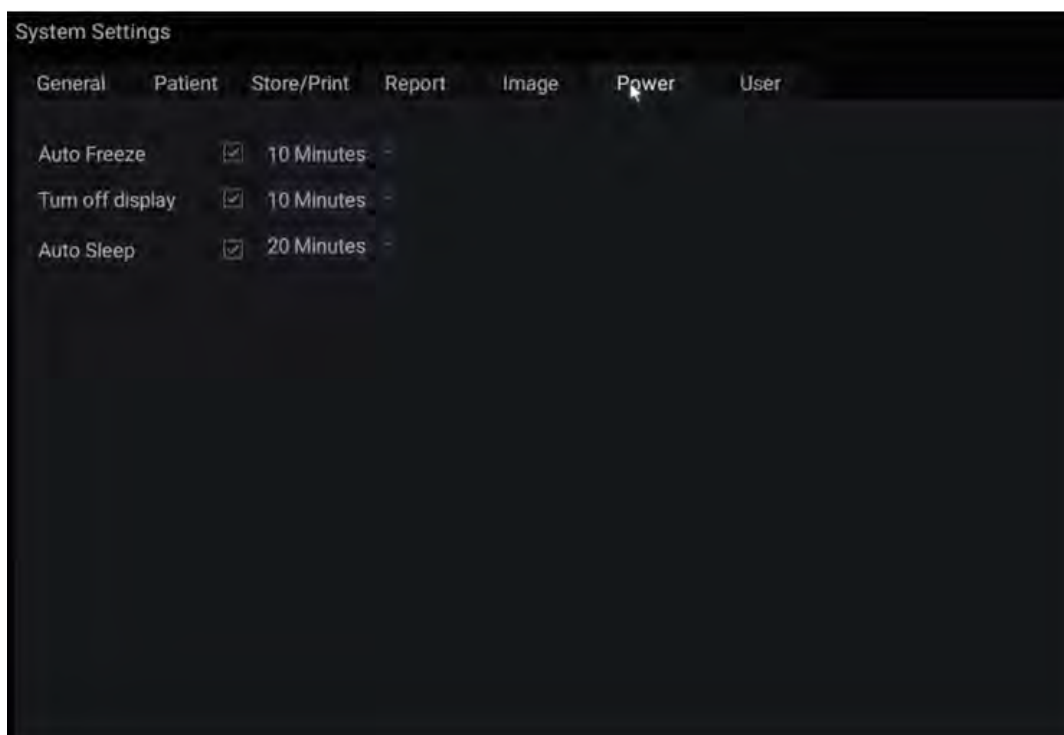


Figure 11-6 Power Set-up Screen

<i>Item</i>	<i>Options</i>	<i>Description</i>
Auto-Freeze & Waiting Time	√/x 1/5/10/15/20/25/30/60min	Set whether to turn on auto-freeze function by default or not; and set the waiting time to perform auto-freeze.
Turn off display & Waiting Time	√/x 1/5/10/15/20/25/30/60min	Set whether to turn on the function of turning off the display by default or not; and set the waiting time to turn off the display.
Sleep & Waiting time	√/x 1/5/10/15/20/25/30/60min	Set whether to turn on system sleep function by default or not; and set the system waiting time to enter sleep mode.

Table 11-6 Power Set-up Description

11.1.7. User Set-up

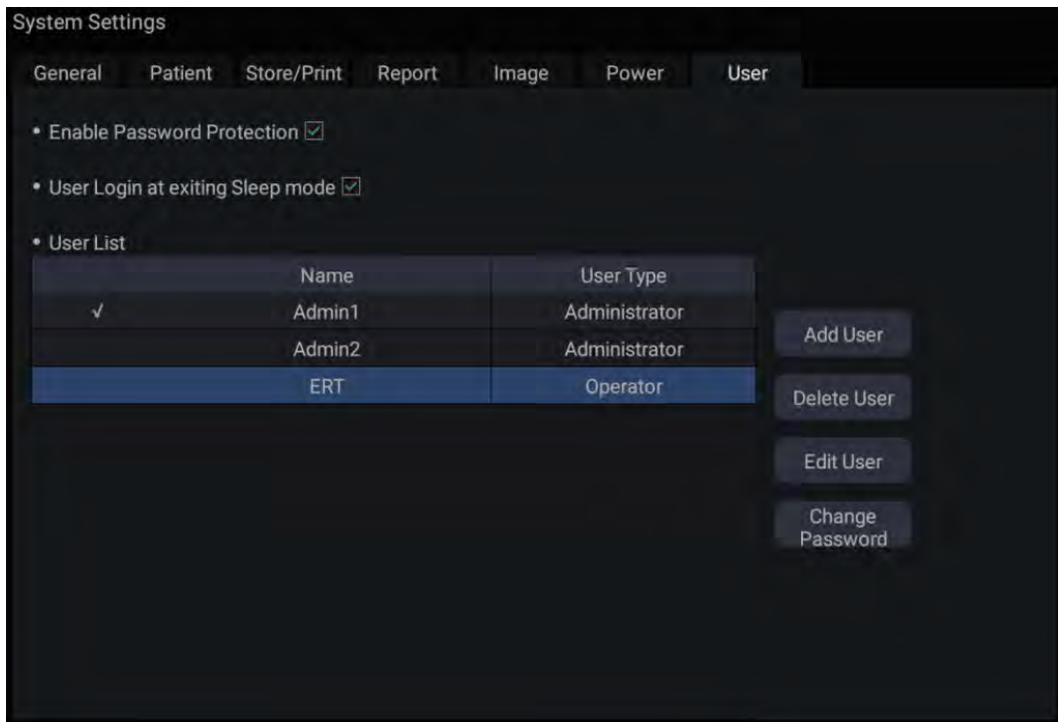


Figure 11-7 User Set-up Screen

<i>Item</i>	<i>Options</i>	<i>Description</i>
Enable Password Protection	√/×	Show or hide the login dialog when booting up the system. Password is required to enable password protection function.
User Login at exiting Sleep mode	√/×	Set whether to display the User Login dialog for user login when exiting the sleep mode.
User List	√/×	Show all users displaying user name and user type. Click the dialog before the user to select this user for edit operation

Table 11-7 User Set-up Information

User type includes Administrator and Operator.

- Administrator users have authority to enable/disable password protection, add/delete/edit users and can view all exams in the patient database. There is one pre-defined administrator user called Admin.
- Operator users can only edit their own user information, change their own password, and view exams that they created.
- There's one pre-defined operator user called Emergency for Emergency login without entering password. The exams created by Administrator and Operator can not be viewed through Emergency login.

There's a couple of buttons for different user edit operation. It includes Add User, Delete User, Edit User, and Change Password.

- **Add User:** Click it to add user in the user list.
- **Change Password:** Click it to change the password of the users.
- **Delete User:** Click it to delete the highlighted user in user list.
- **Edit User:** Click it to modify the user information.

Caution

1. For security consideration, a password with high secure intensity is suggested for each user account, and the password should be changed periodically.
 2. Please keep your user name and password safe.
 3. Set a password with high security for the pre-defined administrator user "Admin" immediately at the first system powering on when you receive the ultrasound system.
 4. Always enable the function of user login with password protection.
 5. When the password of the pre-defined administrator user "Admin" is forgotten, please contact the serviceman for the system password reset.
-
-

11.2 Connectivity

Entering Connectivity Screen:

Open **Utility** page. Press **Set up** touchscreen button, and then the **Connectivity** touchscreen button to access Connectivity screens.

The Connectivity screens support configuration of network access and services. It is divided into 2 tabs:

- **TCP/IP:** Configures access to the network from the system.
- **DICOM:** Configures network DICOM services.

WARNING

1. Please build a secure network environment for your ultrasound system to protect the patient data being attacked during network transmissions.
 2. Patient data transmitted by the system is encrypted with AES algorithm.
 3. Please ensure the physical security of the network by trying the following measures:
 - a) Install IDS(Intrusion Defense System) and IPS(Intrusion Protection System) software in the network environment where your ultrasound systems are used.
 - b) Use a network that is isolated from the external environment by a firewall.
 - c) Use the WPA2 protocol for authentication and encryption of wireless network, and a password with high secure intensity is required.
 - d) Do not connect the ultrasound system and non-medical devices to a same network.
 4. Anti-virus software is not installed on this device. Please take anti-virus measures in the network environment where your ultrasound systems are used.
-
-

11.2.1. TCP/IP

This screen configures access to a network.

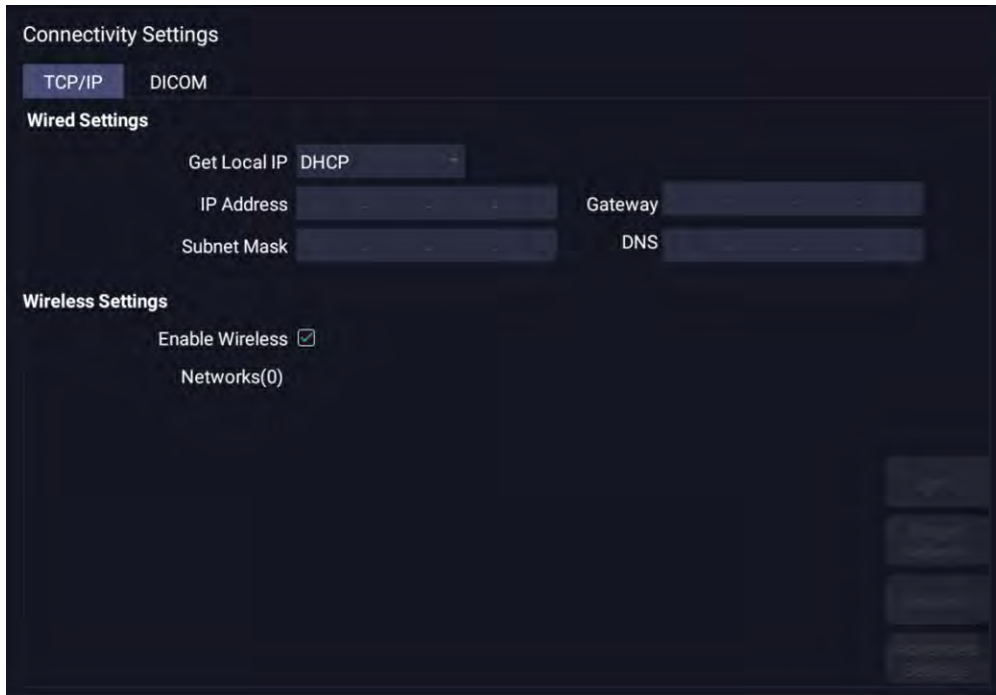


Figure 11-8 TCP/IP settings

Wired Settings:

The following settings apply when connecting a system to a wired network via the network port on the side of the system.

Get Local IP: Either Manually entered (Static) or DHCP. The correct setting will depend on how your DICOM network is administrated. If you are unsure, try DHCP first. Generally a Static IP is only needed if the target PACS system requires it. If it is needed, contact your network IT manager.

IP Address, Subnet Mask, Gateway, DNS: These settings determine how the system communicates with your network. If you chose DHCP then your network router will set these automatically. If you chose Manually Entered IP then contact your network IT manager for the appropriate settings.

Wireless Settings:

Enable Wireless: This will turn the wireless radio on/off. No wireless networks are displayed when this is disabled.

Networks: When wireless is enabled the system will search for wireless networks that are available and display them in this list. Networks that have been previously accessed will show up with an asterisk (“*”). If there is currently an active network it will show up with a checkmark (‘√’). If the network requires a password it shows up with a lock icon. Each displayed network shows the strength of the wireless signal.

Refresh: Clicking on this button updates the list of displayed networks.

Add: Clicking on this button brings you a window for connecting a hidden WiFi network by entering its network name, security protocol, and password.

The following controls require that a wireless network has been selected from the network list. Click on the name of a network to select it.

Join: This joins the selected network. If a password is needed a dialog box will be displayed to enter it.

Forget Network: This forgets any password of the selected network that had been entered, but the network is still shown in the list.

Advanced Settings: This brings up a dialog box with additional settings for the selected wireless network. The dialog box includes the following:

- **Password:** This is useful when the network password has changed.
- **Method:** Either Manually entered (Static) or DHCP. Generally wireless networks use DHCP, and a Static address is only needed if required by the target PACS system.
- **IP Address, Subnet Mask, Gateway, DNS:** If you chose DHCP then your network router will set these automatically. If you chose Manually Entered IP then contact your network IT manager for the appropriate settings.

11.2.2. DICOM

This screen configures DICOM services, including Store and Modality Worklist.

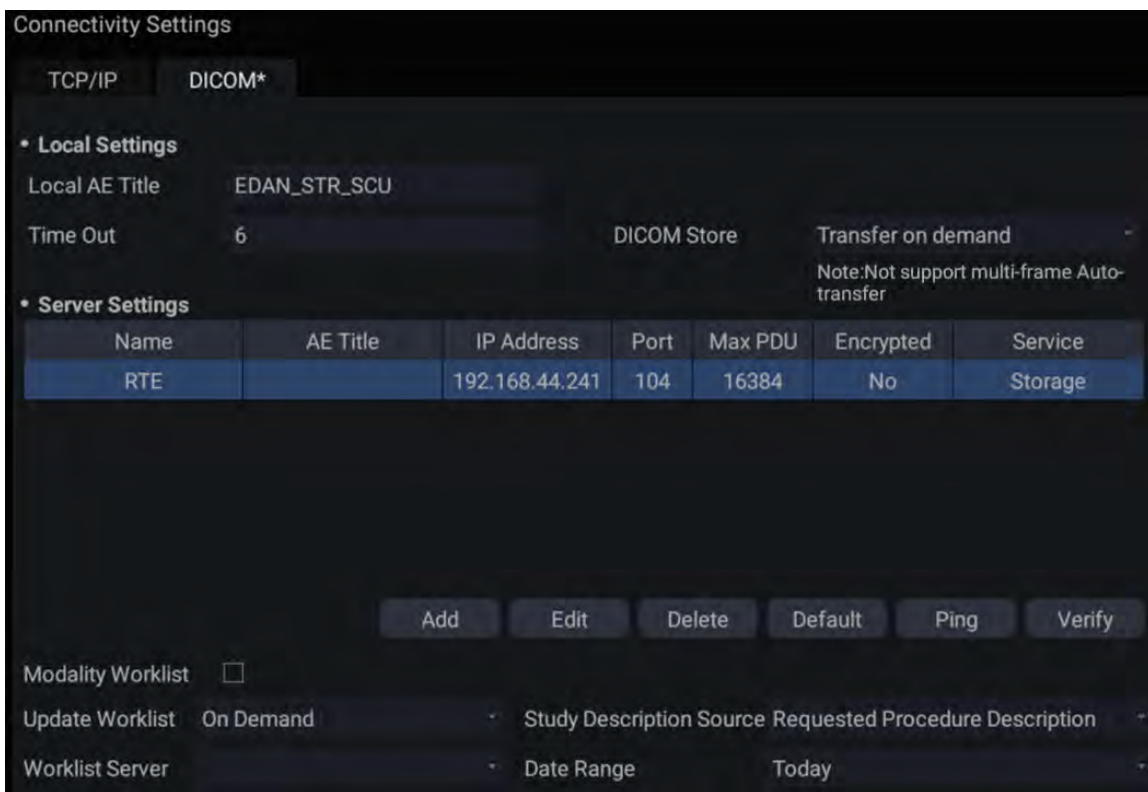


Figure 11-9 DICOM Settings

Local Settings:

These settings determine how the system communicates with other DICOM devices. These are required for both Store and for Modality Worklist.

Local AE Title: Any 16 characters that uniquely identify this system on your DICOM network. The default “EDAN_STR_SCU” will work unless you have multiple Edan systems on your network.

Time Out: This determines the time after which this system will stop trying to establish a connection to the DICOM server.

DICOM Store: This determines when DICOM images and clips are sent to the server. The options are:

- **Transfer on demand:** Images and clips reports are only sent when you manually send them. When there is no exam in progress the Review hard key will show a list of all exams on the hard drive. Select an exam and press the Send button at the bottom of the screen.
- **Auto-Transfer when Store:** Each image is sent automatically when it is captured. This has the advantage that images are immediately available for review at the server while the exam is in progress.
- **Auto Transfer when End Exam:** Images are sent automatically when the exam is ended. This is the most common setting.

Note:

Current release does not support the auto-transfer of clips to a DICOM server.

Server Settings:

Server list: The main interaction in this section is a list of configured servers. It starts off as an empty list, and grows as servers are added. Most sites will only use one server, but if the system is moved between locations then multiple servers may be entered.

- **Name:** The name of the server that appears in the drop-down list of the patient database
- **AE Title, IP Address, Port, Max PDU:** These are the settings of the destination DICOM server; it's how the system finds the DICOM server on your network. The AE title and IP Address are unique to your network; contact your network IT manager for these settings. The most common setting of Remote Port for DICOM servers is 104, although your server may be different.
- **Encrypted:** Shows whether this DICOM server is encrypted for DICOM store process. To encrypt the DICOM store process, check the **Encryption** item in the window when you add or edit a DICOM server. You could use the default TLS encryption protocol or import other encryption protocols generated from your DICOM server.
- **Service:** Shows the service type of this DICOM server, including Storage, Worklist, and Storage&Worklist.

Testing the server: There are two tests to ensure that the server information is entered correctly. Click on any field for a given server to make that server selected, then:

- **Ping:** A successful Ping means that the system can communicate with the server at a low-level; basically that the two computers 'see' each other. As a security measure, some servers on the Internet may be configured to not respond to a Ping even if the connection is successful.
- **Verify:** A successful Verify means that the system can communicate with the server at a DICOM level; basically that the DICOM on both computers understand each other. A successful Verify will typically mean that your DICOM configuration is correct.

Other controls:

- **Add:** Adds another line in the list of servers.
- **Edit:** Edits the information of a selected server.
- **Delete:** Deletes the selected server.

Modality Worklist: Modality Worklist will query the configured server for a list of all ultrasound exams scheduled within the configured date range.

Enable: Turns Modality Worklist on/off.

Update Worklist: Determines when the worklist is updated. Choices are:

- **On Demand:** Updates only when the Update button is pressed from the patient page.
- **On Start of Exam:** Updates when the patient page is displayed at the start of each exam.

Study Description Source: Modality Worklist can fill the ultrasound comments section from the server. Depending on:

- **Requested Procedure Description:** Obtains comments from DICOM tag (0x0010,0x4000);
- **Scheduled Procedure Description:** Obtains comments from DICOM tag (0x0040,0x0007)
- **Comments on The Schedules Procedure Step:** Obtains comments from DICOM tag (0x0040,0x0400)

Worklist Server: Selects the server to query for the worklist. Options include any server configured in **Server Settings** (see previous section).

Date Range: The range of dates for the worklist query. Note, the option of “Yesterday and Tomorrow” includes today’s exams.

11.3 Maintenance

Open **Utility** page and press **Maintenance** touch screen button to access Maintenance screens.

The Maintenance screen provides access to controls that are not typically needed during normal operation of the system.

11.3.1. License

The **License** page displays which features are currently licensed for use on the system. At the top of the screen is displayed the current license key as well as a license QR code. Below that is a list of all licensable features, along with its current status. The system supports temporary trial licenses. Click the **Trail** button can try the function for one time in the valid period of three months. If a feature is so licensed the expiration date is also shown.

- Press **Import** button to import a license file from a USB external storage device. Please contact your distributor or Edan service engineer to obtain a new license key.
- Press **Revert** button to restore the previous license if the imported license is not correct.
- Press **Import Config** button to import config file from a USB external storage device.
- Press **Show Config** button to view the config file showing whether a feature is enabled or not.

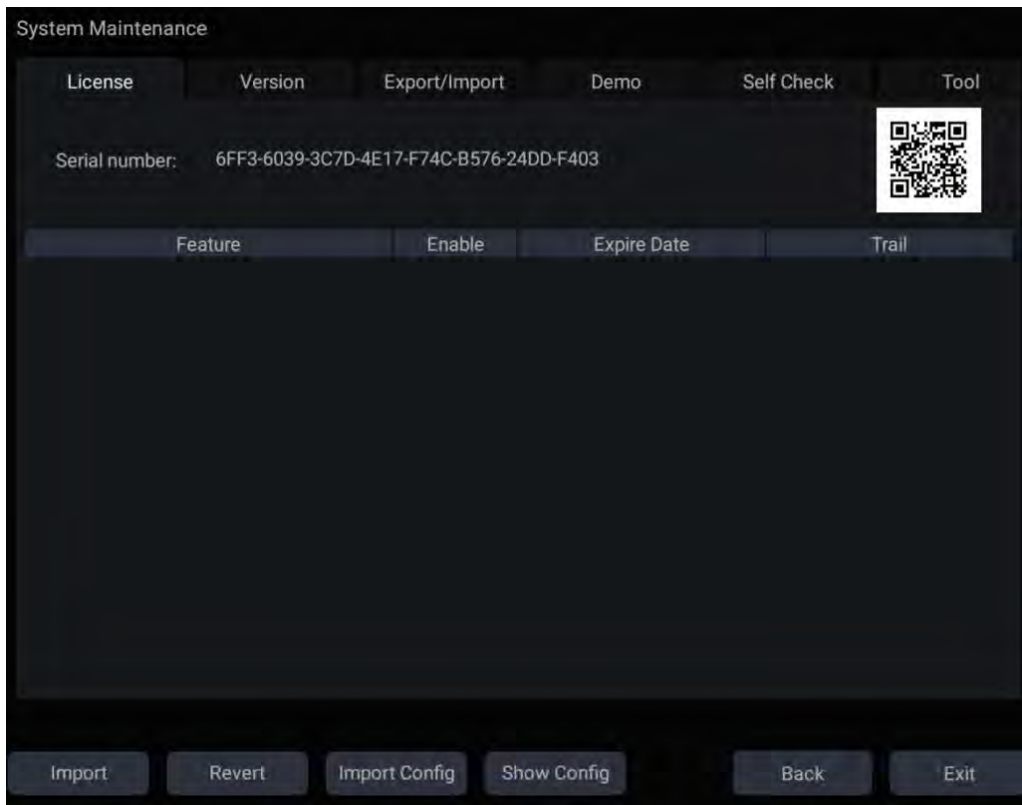


Figure 11-10 System License Screen

11.3.2. Version

The **Version** screen shows the current version of software, firmware, and selected hardware for the system. This information is only needed if requested by an Edan service engineer. This page also includes an **Upgrade** and **Export Logs** button.

Caution

1. Anti-virus measures such as USB device virus scanning should be carried out prior to using USB flash drive.
2. Do not connect an USB device with unknown provenance to the ultrasound system.
3. To avoid loss of patient data, please backup the patient data prior to software upgrade.

11.3.3. Export/Import

The Export/Import screen provides access for you to export/import user-configured presets and settings using an external storage device.

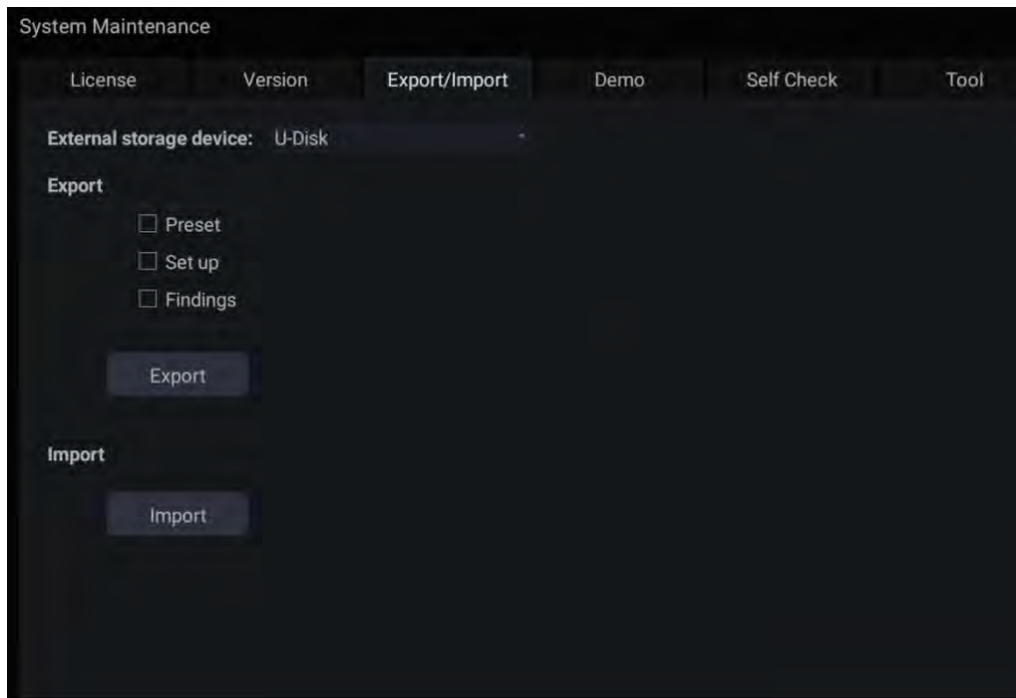


Figure 11-11 Export/Import Screen

To export user data:

1. Select an external USB storage device.
2. Check the items to be exported: Presets, Set Up, Findings.
 - Presets includes the preset data about Exam, imaging parameters, Body Mark, Comments, etc .
 - Set Up includes the setting data about system set-up, connectivity, etc.
3. Press **Export** button to begin the export process.

To import user data:

1. Select an external USB storage device
2. Press **Import** button to bring you a dialog. All the user data on the USB disk will be loaded and displayed. The use data must have been previously exported from a system.
4. Check the items to be imported: Presets, Set Up or Findings.
3. Press **Import** button to begin the import process.

Note:

The Presets and Set-up setting data are only supported to import across ultrasound systems loaded with the same software version.

11.3.4. Demo

The Demo screen provides access for you to show a set of images you collected for demonstration purpose.

Import. Imports a collection of images to the ultrasound system.

1. Before import, you need create any a folder in USB disk and put the images inside.
2. Connect the USB disk to the ultrasound system.
3. Open the **Demo** screen and press **Import** button.
4. Find the path of the folder and press **OK** to import.

SlideShow: Shows an imported collection of images slide by slide.

Export: Exports the imported images to USB storage device.

Delete: Deletes the imported images.

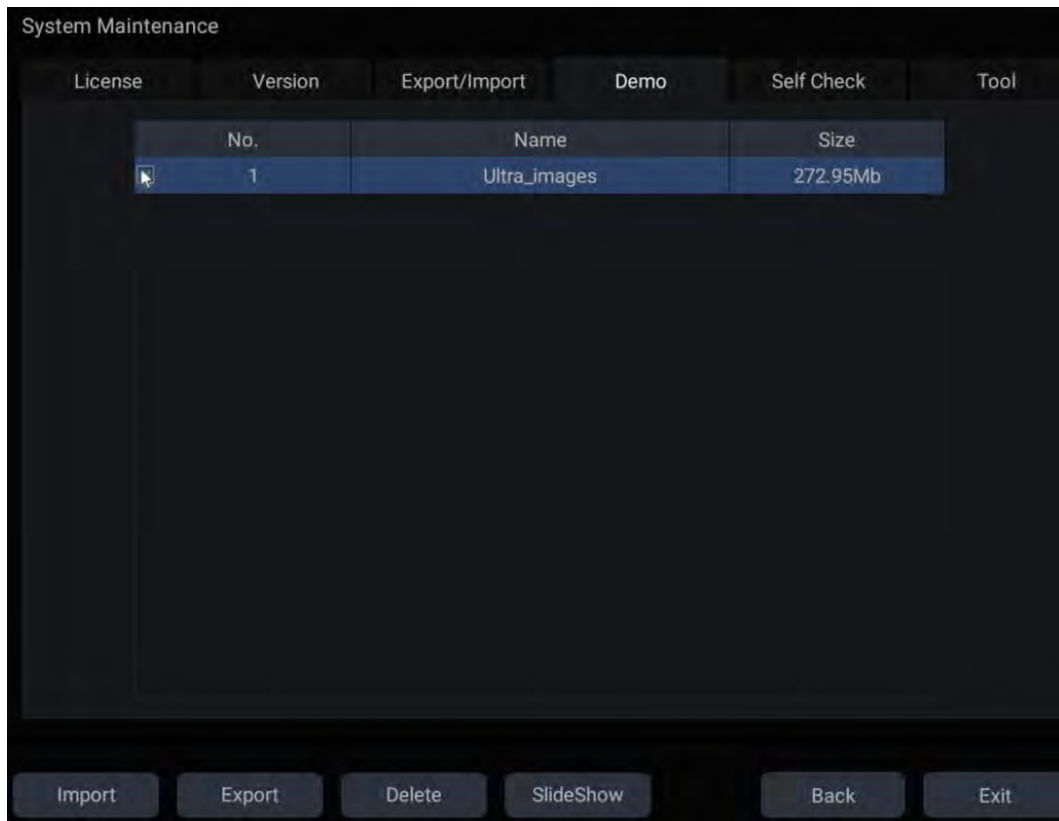


Figure 11-11 Demo Screen

11.3.5. Self-Check

The Self Check screen provides access to checking the fan status and to testing the LCD screen.

11.3.6. Tool

The Tool screen provides access to system maintenance which must be performed by authorized service personnel. Please refer to the Service Manual for the details.

11.3.7. Transducer Element Check

Proper performance of the transducer is the prerequisites for acquiring images or signals that provide the intended information for the users. To ensure the proper performance of a transducer, it is suggested to implement the transducer element check each time a transducer is activated for use or at regular transducer performance check.

To perform transducer element check:

1. Activate a transducer from the **Transducer** touch screen.
2. Open the **Self-Check** screen.
3. Press the **Probe Check** button, and the system will bring you a dialogue.
4. Ensure the residual coupling gel is removed from the transducer, and place the transducer on a flat table without any object around the transducer. Then press **OK** on the dialogue to run the

test.

5. If the transducer element is in malfunction, dark strips will be displayed; if the transducer element functions well, no dark strips will be displayed.

11.4 Screen Adjust

Entering Screen Adjust Screen:

Open **Utility** page. Press **Set up** touch screen button, and then the **Screen Adjust** touch screen button to access Screen Setup touch screen.

The brightness and contrast of the monitor and touch screen in the system can be customized.

- **Main Screen Brightness:** adjusts the brightness value of the monitor.
- **Main Screen Contrast:** adjusts the contrast value of the monitor.
- **Main Screen Color Temp.:** adjusts the color temperature of the monitor.
- **Touch Screen Brightness:** adjusts the brightness value of the touch screen.

Press **Restore all settings** button to restore the factory settings for all the brightness and contrast values.

12 *In Between Exams*

12.1 *Unpacking*

Visually examine the package prior to unpacking. If any signs of mishandling or damage are detected, contact the carrier to claim for damage. After unpacking the device, you should follow the packing list to check the product carefully and to make sure that no damage has occurred during transportation. For installation, please contact your local distributor or the EDAN service department at: support@edan.com.

WARNING

1. Do not use the device if it is found to be damaged or defective.
 2. Do not drop or collide with the transducer. Otherwise you shall give up using it.
-

12.2 *Transport*

Power off the system and secure all accessories before moving it to another location.

CAUTION

- 1 Switch off the ultrasound system. Unplug the AC plug from the power source and secure the power cable.
 - 2 Remove the transducer and place them in a safe place.
 - 3 Disconnect and secure the connecting cable.
 - 4 Connect optional system accessories.
 - 5 Secure the system and complete the system setup, and then perform all the daily checking before using it.
-

To prepare the system for shipment over long distances or rough terrain, repack the system in the factory packing

To prepare the system for transport over distances: load the system into a vehicle using a lift gate.

To prevent lateral movement of the system, secure the system with cargo straps. To prevent sudden jarring of the system during transport, provide anti-shock cushions beneath the system.

It is suitable for transportation by air, railway, highway and ship. Protect the system from inversion, collision, and splashing with rain and snow.

12.3 *Storage*

- ◆ Do not place the device near the ground, walls or the roof.
- ◆ Keep good indoor ventilation. Avoid strong and direct sunlight, and erosive gas.

13 Troubleshooting and Maintenance

In order to ensure proper system operation and function, a maintenance and inspection plan should be established to periodically check the safety of the system. If any system malfunction is experienced, contact EDAN or authorized representatives.

13.1 Daily Checklist

Check before the system is switched on, if any system malfunction is experienced, eliminate the malfunction before use, or contact EDAN or authorized representatives for service if needed.

- ◆ Visually inspect all the transducers. Do not use any damaged transducer.
- ◆ Visually inspect all the transducer assembly cables and associated connectors.
- ◆ Visually inspect all the cords. Do not turn on the power if a cord is frayed or split, or shows signs of wear.
- ◆ Verify that the controls are clean and free from gel or contaminants.

Check after the system is switched on:

- ◆ Visually check the on-screen display and lighting. Verify that the monitor displays the current date and time and there isn't any error message.
- ◆ Verify that the transducer identification and indicated frequency on the screen are correct for the activated transducer.
- ◆ Ensure that there isn't obvious abnormal noise, discontinuous image or dark area.
- ◆ Ensure that it isn't smelly or too hot.
- ◆ Ensure that the ultrasound window isn't too hot, checking with your hand.
- ◆ Verify that the buttons on the keyboard are good to operate.
- ◆ Ensure that there isn't obvious abnormal noise from the loudspeakers.
- ◆ Ensure that there isn't obvious abnormal noise from the air fan.

13.2 Troubleshooting

If any persistent system malfunction is experienced, e.g. an onscreen error message, blank imaging screen, absent menus, please refer to the following table below. If the failure cannot be eliminated, please contact EDAN or authorized representatives.

<i>Item</i>	<i>Problem</i>	<i>Solution</i>
1.	When the power switch is on, there isn't any image displayed.	<ol style="list-style-type: none"> 1. Check power supply. 2. Check wires and plugs.

2.	Strip-shape or snowflake-shape disturbance occurs on the display screen.	<ol style="list-style-type: none"> 1. Inspect the power supply. 2. Check whether it is disturbed by the ignition action of any other device. 3. Check the disturbance of electric or magnetic field in the surrounding environment. 4. Check whether the plug and socket of power supply and transducer are properly connected.
3.	Image is not displayed clearly on the screen.	<ol style="list-style-type: none"> 1. Adjust overall gain (Gain). 2. Adjust eight TGC slide controls. 3. Adjust focus (the number and the position).
4.	Image window is dark.	<ol style="list-style-type: none"> 1. Adjust the brightness and slide the TGC controls on the touch screen. 2. Check whether the transducer is connected well.
5.	The button is unresponsive	<ol style="list-style-type: none"> 1. Check the control panel to see whether the button is blocked and press it several times to release it. 2. Clean the button

13.3 System Cleaning and Disinfection

Use only the EDAN-approved substances and methods listed in this chapter to clean the system. The warranty does not cover damage caused by using unapproved substances or methods.

Edan Instruments has validated the cleaning and disinfection instructions included in this User Manual. It is the responsibility of the healthcare professional to ensure that the instructions are followed so as to ensure adequate cleaning and disinfection.

General Points:

Keep your monitor, cables and accessories free of dust and dirt. To prevent the device from damage, please follow the procedure:

- Use only recommended cleaning substances and disinfectants listed in this manual. Others may cause damage (not covered by warranty), reduce product lifetime or cause safety hazards.
- Always dilute according to the manufacturer's instructions.
- Unless otherwise specified, do not immerse any part of the equipment or any accessories in liquid.
- Do not pour liquid onto the system.
- Do not allow liquid to enter the case.
- Never use abrasive material (such as steel wool or silver polish).
- Inspect the monitor and reusable accessories after they are cleaned and disinfected.

WARNING

The console is not waterproof. Do not immerse or expose to extended moisture. Splash resistance does not extend to transducer connectors. Keep connectors dry.

System Surface Cleaning

The validated cleaning agents for cleaning the system are:

- Ethanol (75%)
- Isopropanol (70%)

To clean the system surface:

1. Switch off the system and unplug it.
2. Wear sterile protective gloves to prevent infection.
3. Remove all residual foreign matters from the system surface using sterile cloth or paper towel immediately after examination.
4. Use a sterile cloth dampened with cleaning agent to gently wipe the entire exterior surface, including the screen, of the equipment thoroughly until no visible contaminants remain.
5. After cleaning, wipe off the cleaning agent with a sterile cloth dampened with tap water until no visible cleaning agent remains.
6. Wipe off with a dry sterile cloth to remove residual moisture.
7. Leave the system to air dry.
8. If the system is not visually clean at the end of the cleaning steps, please repeat the cleaning steps through step 4 to step 7.
9. Inspect the system to ensure that there is no damage.

NOTE:

1. Make sure the system is free of gel and any other visible residue.
2. Use a soft dry cloth without chemicals for cleaning. The monitor surface is easily scratched.

To clean the trackball:

1. Remove the front panel bezel.
2. Remove the trackball as shown in [Figure 13-1](#).
3. Wipe the trackball, X and Y rollers, and the auxiliary idler wheel with a sterile cloth dampened with the cleaning solution until no visible contaminants remain.
4. Wipe off the cleaning solution with a new sterile cloth dampened with tap water after cleaning until no visible cleaning agent remains.
5. Wipe off with a dry sterile cloth to remove residual moisture.
6. Leave the trackball, X and Y rollers, and the auxiliary idler wheel to air dry.
7. Assemble the trackball and front panel bezel after the assembly parts completely dry.

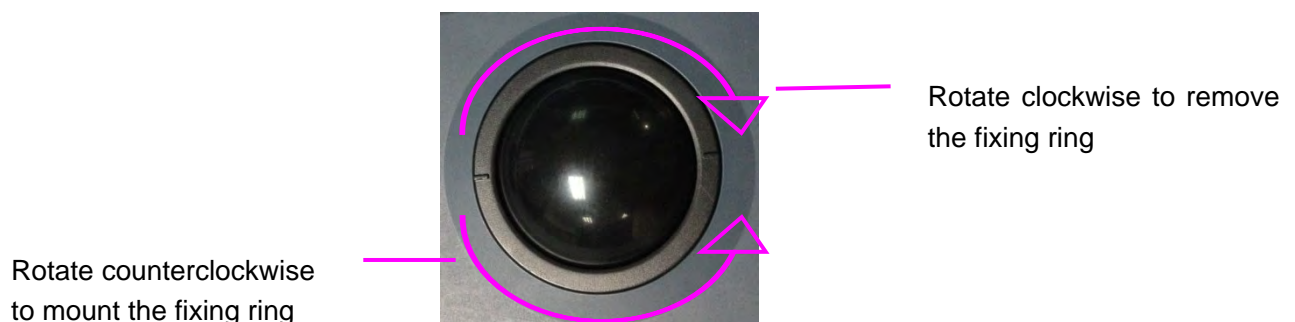


Figure 13-1 Assembling and Disassembling Trackball

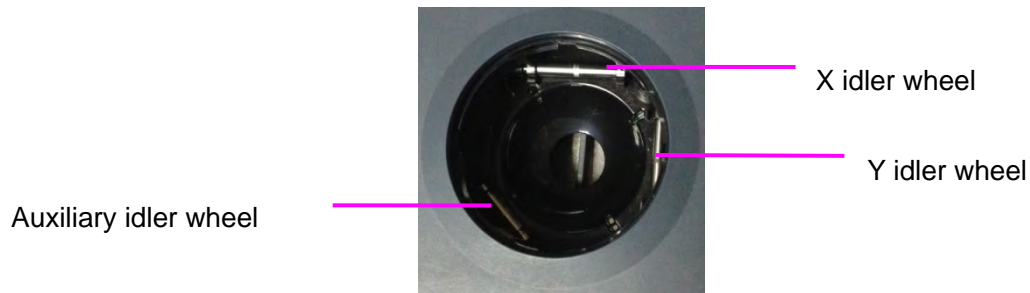


Figure 13-2 X, Y and the Auxiliary Idler Wheels

CAUTION

Do not drop or place foreign objects inside the trackball assembly or it may affect the trackball operation and damage the system.

NOTE:

Be sure to clean the X and Y idler wheels and the auxiliary idler wheel.

System Surface Disinfection

The validated disinfecting agents for disinfecting the system are:

- Ethanol (75%)
- Isopropanol (70%)

To disinfect the system surface:

1. Switch off the system and unplug it.
2. Wear protective gloves to prevent infection.
3. Clean the system prior to disinfection.
4. Prepare the disinfectant solution.
5. Wipe the entire exterior surface of the equipment thoroughly with a soft sterile cloth dampened with the disinfectant solution. Follow the disinfectant manufacturer's recommended contact time and mode.
6. After disinfection, wipe off the disinfecting agent with a new sterile cloth dampened with sterile water.
7. Wipe the system with a dry sterile cloth or leave the system to air dry.
8. Inspect the system to ensure that there is no damage.

13.4 Maintenance

The system should be maintained regularly, at least annually, by a qualified technician who has adequate training, knowledge and experience. That person should be familiar with the Service Manual, available from your Edan representative.

Appendix A Specifications

A.1 Electrical Safety Classifications

According to the type of protection against electric shock	Internally powered equipment, Class I equipment
According to the degree of protection against electric shock	Type BF
According to the degree of protection against harmful ingress of liquid	Whole device: IPX0 Transducer (not including the transducer connector): IPX7; Footswitch: IP68
According to the degree of safety of application in the presence of a flammable gas	Equipment not suitable for use in the presence of a flammable gas
According to the mode of operation	Continuous operation
According to the grade of EMC	CISPR 11 Group 1, Class B
Standards Compliance	EN 60601-1:2006/A1:2013 idt IEC 60601-1: 2005/A1:2012 EN 60601-1-2: 2015 idt IEC 60601-1-2: 2014 EN 60601-2-37:2008/A1:2015 idt IEC 60601-2-37:2007/A1:2015

A.2 Power Supply

Operating Voltage	100 -240 V~
Operating Frequency	50 Hz/60 Hz
AC Input Current	2.5A-1.2A

A.3 Battery

Capacity	6800mAh*2
Voltage	14.4V
Working time	About 1.5 hours(1/2 scanning+1/2 frozen)
Charging time	About 6 hours when the system is powered on. About 3 hours when the system is powered off.

A.4 Machine Specifications

Main unit dimensions	Maximum dimension: 1640±5mm(H)×544±3mm(W)×665±3mm(D)
Weight	55kg (not including transducer and accessories)

A.5 Display Specifications

Display	TFT-LCD
Diagonal Size	21.5 inch
View Angle	Right 178°, Left 178°, Up 178°, Down 178°
Pixel Number	1920x1080
Contrast Ratio	1000 (Typical)

A.6 General Specifications

Display Modes	<p>B Mode: B, 2B</p> <p>Color Mode: B/C(Single, Dual); B+B/C(Dual Live); B/C/PW (triplex mode)</p> <p>PDI/DPDI Mode: B/PDI(DPDI) (Single, Dual); B+B/PDI(DPDI) (Dual Live); B/PDI(DPDI)/PW (triplex mode)</p> <p>PW Mode: B/PW;(Update) B/PW; (duplex, simultaneous) B/C/PW(Update) B/C/PW, B/PDI(DPDI)/PW; (triplex mode)</p> <p>CW Mode: B/CW; B/C/CW, B/PDI(DPDI)/CW;</p> <p>M Mode: B/M (Display layout: Up/down, Left/right)</p> <p>TDI Mode: B+ TVI (Dual Live) B+ TVI+TVD (Update) B+ TVI + TVD ((triplex mode)</p> <p>3D/4D: 3D Rendering, 3 Sectional Planes</p>
Hard Drive storage	512GB or 1TB
Report Packages	Abdomen, Obstetrics, Small Parts, Vascular, Cardiac, Gynecology, Urology, Pediatrics.

A.7 Wi-Fi Specifications

Standard Conformance	802.11b, 802.11g ,802.11n
Frequency Band	2.412-2.484GHz(@2.4GHz band)
Modulation Technique	OFDM DSSS CCK
Typical Transmit Power(± 2 dBm)	2.4G Transmit 1MbpsDSSS :17.3dBm 2MbpsDSSS :17.3dBm 5.5MbpsCCK :17.3dBm 11MbpsCCK :17.3dBm 6MbpsOFDM: 17.1dBm 9MbpsOFDM :17.1dBm 12MbpsOFDM: 17.1dBm 18MbpsOFDM :17.1dBm 24MbpsOFDM :16.2dBm 36MbpsOFDM :15.3dBm 48MbpsOFDM :14.6dBm 54MbpsOFDM: 13.8dBm
Wi-Fi Quality of Service	
Data rate	802.11b: up to 11 Mbps @ 2.4 Ghz 802.11g: up to 54 Mbps @ 2.4 Ghz 802.11n: up to 65 Mbps @ 2.4 Ghz
Data security	WPA2 encryption
Application-layer delay	No requirement. It's not used in real time.
Application-layer reliability	No requirement. Application failure will be notified to the user immediately.
System capacity	No more than one device will be allowed to connect with the ultrasound system.
System anti-interference	Can be coexistent with other Wi-Fi devices.
Network interruption alarm	Network interruption is notified by disconnection icon and failure in transmission is notified in Transfer Status window.
EMC test process	Wi-Fi function is not affected when the system is imposed with radiation interference complied with IEC60601-1-2:2014 standard.

A.8 Operating, Storage and Transportation Environment

A.8.1 Operating Environment

Temperature	0 °C ~ +40 °C(+32 °F~+104 °F)
Relative humidity range	15% RH ~ 95% RH(non-condensing)
Atmospheric pressure range	86kPa ~ 106kPa

A.8.2 Storage and Transportation Environment

Temperature	-20 °C ~ +55 °C(-4 °F~+131 °F)
Relative humidity range	15% RH ~ 95% RH(non-condensing)
Atmospheric pressure range	70kPa ~ 106kPa

A.9 Transducer Specifications

No.	Transducer	Center Frequency	No.	Transducer	Center Frequency
1	L17-7HQ	12.0MHz	2	E8-4Q	6.2MHz
3	C6-2MQ	3.9MHz	4	C5-1Q	3.25MHz
5	C5-2Q	3.5MHz	6	L12-5Q	8.0MHz
7	L17-7SQ	12.0MHz	8	MC8-4Q	6.2MHz
9	P5-1Q	2.7MHz	10	P7-3Q	5.0MHz
11	MC9-3TQ	6.4MHz	12	C7-2XQ	3.3MHz
13	E10-3BQ	6.5MHz	14	E10-3HQ	6.5MHz

A.10 Configuration Difference

Models	Configuration Difference		
	Feature 1	Feature 2	Feature 3
	Seminal Vesicle Meas.	Testis Meas.	Single Button Footswitch
Acclarix LX3	X	√	√
Acclarix LX3 Exp	√	X	√
Acclarix LX3 Super	√	√	√
Acclarix LX25	X	√	X
Acclarix LX28	√	X	X

Appendix B Ultrasound Intensity and Safety

B.1 Ultrasound in Medicine

The use of diagnostic ultrasound has proved to be a valuable tool in medical practice. Given its known benefits for non-invasive investigations and medical diagnosis, including investigation of the human fetus, the question of clinical safety with regards to ultrasound intensity arises.

There is no easy answer to the question of safety surrounding the use of diagnostic ultrasound equipment. Application of the ALARA (As Low As Reasonably Achievable) principle serves as a rule-of-thumb that will help you to get reasonable results with the lowest possible ultrasonic output.

The American Institute of Ultrasound in Medicine (AIUM) states that given its track record of over 25 years of use and no confirmed biological effects on patients or instrument operators, the benefits of the prudent use of diagnostic ultrasound clearly outweigh any risks.

B.2 Ultrasound Safety and the ALARA Principle

Ultrasound waves dissipate energy in the form of heat and can therefore cause tissue warming. Although this effect is extremely low with Transcranial Doppler, it is important to know how to control and limit patient exposure. Major governing bodies in ultrasound have issued statements to the effect that there are no known adverse effects from the use of diagnostic ultrasound, however, exposure levels should always be limited to As Low As Reasonably Achievable (the ALARA principle).

Imaging Functions Affecting Acoustic Output

In addition to the level of voltage transmitted, adjustment of the following imaging functions and /or controls may affect the acoustic output.

Item	Affection
Probe	Acoustic output will be changed with the change of probe.
Imaging mode	There are different parameters applied in B mode, Color mode, M mode, and PW mode, so acoustic output will be changed with the change of among B mode, Color mode, M mode, and PW mode.
Field of view (scan angle or scan width)	Frame rate may be changed with the change of the scan angle or the scan width, and the acoustic output will also be changed.
Image depth	Pulse repeated frequency will be changed with the change of the image depth, and the acoustic output will be changed.
Focus number	Frame rate and focus position will be changed with the change of the focus number, and acoustic output will also be changed.
Focus position	Beam power level and the beam aperture will be changed with the change of the focus position, and acoustic output will also be changed
Freeze	When freezing the system, it will stop transmitting ultrasonic wave.
Transmission power	The output of probe will be changed with the change of the transmission power, and acoustic output will be changed.
Multi-frequency	The character of the wave focus will be changed with the change of the frequency, and acoustic output will be changed.

Line density	The acoustic output will be changed with the change of the number of the scanning line (line density).
PRF	The acoustic power will be changed with the change of PRF.
Sample volume	The pulsed wave and the power will be changed with the change of the sample volume, and acoustic output will be changed.
Presets	Presets contain all the parameters above, so any change of the presetting will change acoustic output.
Restart, or power on/off	System will return to the default setting when restarting, or powering on/off the system, and acoustic output will be changed.

B.3 Explanation of MI/TI

B.3.1 MI (Mechanical Index)

Cavitations will be generated when ultrasound wave passes through and contacts tissues, resulting in instantaneous local overheating. This phenomenon is determined by acoustic pressure, spectrum, focus, transmission mode, and factors such as states and properties of the tissue and boundary. This mechanical bioeffect is a threshold phenomenon that occurs when a certain level of ultrasound output is exceeded. The threshold is related to the type of tissue. Although no confirmed adverse mechanical effects on patients or mammals caused by exposure at intensities typical of present diagnostic ultrasound instruments have ever been reported, the threshold for cavitation is still undetermined. Generally speaking, the higher the acoustic pressure, the greater the potential for mechanical bioeffects; the lower the acoustic frequency, the greater the potential for mechanical bioeffects.

The AIUM and NEMA formulate mechanical index (MI) in order to indicate the potential for mechanical effects. The MI is defined as the ratio of the peak-rarefactional acoustic pressure (should be calculated by tissue acoustic attenuation coefficient 0.3dB/cm/MHz) to the square root of acoustic frequency.

$$MI = \frac{P_{r,a}}{\sqrt{f_{awf}} \times C_{MI}}$$

Where, $C_{MI} = 1 \text{ Mpa} \cdot \text{MHz}^{-1/2}$, $P_{r,a}$ is the Attenuated Peak-rare-factional Acoustic Pressure and f_{awf} is Acoustic Working Frequency.

B.3.2 TI (Thermal Index)

Heating of tissues is caused by absorption of ultrasound when the ultrasound energy is applied. The temperature rise is determined by the acoustic intensity, exposed area and thermophysical properties of the tissue.

In order to indicate the potential for temperature rise caused by thermal effects, the AIUM and NEMA formulate thermal index (TI). It is defined as the ratio of the total acoustic power to the acoustic power required to raise the tissue temperature by 1°C.

According to different thermophysical properties of the tissue, TI is divided into three kinds: TIS, TIB and TIC.

TIS (Soft Tissue Thermal Index): It provides an estimate of potential temperature rise in soft or similar tissues.

TIB (Bone Thermal Index): It provides an estimate of potential temperature rise when the ultrasound beam passes through soft tissue and a focal region is in the immediate vicinity of bone.

TIC (Cranial Bone Thermal Index): It provides an estimate of potential temperature rise in the cranial

bones or superficial bones.

B.3.3 Display of MI/TI

The system provides real-time display of MI/TI values in the upper right part of the screen. The start point of MI/TI value is 0.0.

The operator should monitor these values during examinations and keep the exposure time and output level at the minimum amounts needed for effective diagnosis.

The display precision is 0.1.

MI display error:

When measured $MI \leq 0.5$, the absolute display error ≤ 0.25 ;

When measured $MI > 0.5$, the relative display error $\leq \pm 50\%$.

TI display error:

When measured $TI \leq 2.0$, the absolute display error ≤ 1.0 ;

When measured $TI > 2.0$, the relative display error $\leq \pm 50\%$.

B.4 Acoustic Output

B.4.1 Factors that Contribute to Uncertainty in the Output Display

A number of factors should be considered in display accuracy determination methods, such as:

- Transducer variability
- System variability
- Measurement variability and accuracy
- The number of operating conditions of which the system is capable and the number tested in obtaining display accuracy results
- Whether display accuracy will be determined by specific combinations of system, mode, transducer assembly and transmit patterns, or all allowed combinations of them
- Accuracy of system software MI and TI calculation algorithms.
- Engineering approximations for real-time calculations

B.4.2 Differences between Actual and Displayed MI/TI

Actually, many assumptions adopted in the process of measurement and calculations are relatively conservative. Over-estimation of actual in situ intensity exposure, for the majority of tissue paths, is made to the measurement and calculation process. For example, attenuation coefficient of 0.3 dB/cm·MHz, which is much lower than the actual value for most tissues of the body, is adopted. And conservative values of tissue characteristics are selected for use in TI models. Therefore, the display of MI and TI should be used as relative information to assist operator in prudent use of ultrasound system and implementation of ALARA principle, and the values should not be interpreted as the actual physical values in tissues or organs examined.

B.4.3 Measurement Uncertainty

Measurement uncertainties table

	<i>Intensity</i>	<i>Pressure</i>	<i>Power</i>	<i>Center frequency</i>	<i>MI</i>
Uncertainty(K=2)	$\pm 29.32\%$	$\pm 14.66\%$	$\pm 29.32\%$	$\pm 0.20\%$	$\pm 14.66\%$

B.4.4 Acoustic Power Default Settings

The ultrasound system allows direct control of acoustic power by the Power paddle key on the touch screen. The range can be adjusted is 10% to 100%. The higher the acoustic power number, the greater the acoustic output.

The factory default settings of acoustic power is 100%. The default settings can be reconfigured by



the operator through the Acoustic Power item on **->Preset->Image Preset** page. The ultrasound system switch to default settings upon power up, new patient, new exam or new transducer.

B.4.5 Acoustic Output Limits

In accordance with the FDA Track 3 requirements, the maximum acoustic output level from any transducer in any operating mode is expected to fall below the limits as listed below.

FDA Maximum Acoustic Output Limits for Track 3(Attenuated Values)

Application	$I_{spta.3}(mW/cm^2)$	MI	TIS/TIB/TIC
Regions(except eyes)	≤ 720	≤ 1.9	≤ 6.0

B.5 Operator Control Features

The possibility of producing mechanical/thermal biological effects can be influenced by three kinds of controls: Direct Controls, Indirect Controls, and Receiver Controls. The qualified operator may use the system controls to minimize the ultrasound output while acquiring necessary clinical information.

◆ Direct Controls

The acoustic output of the system can be controlled directly through the level of voltage transmitted. In this case, the maximum acoustic output never exceeds the limits in any mode of operation.

◆ Indirect Controls

The acoustic output of the system can be controlled indirectly through many imaging parameters, including imaging modes, field of view, line density, probe frequency, focus number/position, depth and pulse repetition frequency (PRF).

The imaging mode determines whether the ultrasound beam is scanning or non-scanning. Thermal bioeffect is closely associated with B, M, PW and Color mode.

Acoustic attenuation of tissue is directly connected to probe frequency.

The focus number/position is related to active aperture of probe, beam width and frame rate.

The higher PRF (pulse repetition frequency), the more output pulses occur over a period of time.

◆ Receiver Controls

The receiver controls (such as gain, TGC, dynamic range and image processing), which are used to improve image quality, have no effect on acoustic output. Thus these controls should be optimized before increasing acoustic output.

B.6 Prudent Use Statement

Although no confirmed bioeffects on patients caused by exposure from present diagnostic ultrasound equipment have ever been reported, the potential exists that such bioeffects may be identified in the future. Therefore, the ultrasound should be used prudently. High levels of acoustic output and long exposure time should be avoided while acquiring necessary clinical information.

B.7 References for Acoustic Output and Safety

1. "Bioeffects and Safety of Diagnostic Ultrasound" issued by AIUM in 1993
2. "Medical Ultrasound Safety" issued by AIUM in 1994
3. IEC 62359:2017, Ultrasonics - Field characterization - Test methods for the determination of thermal and mechanical indices related to medical diagnostic ultrasonic fields.
4. Guidance for Industry and FDA Staff: Information for Manufacturers Seeking Marketing Clearance of Diagnostic Ultrasound Systems and Transducers, June 27, 2019 by U.S. Department of Health and Human Services, Food and Drug Administration.
5. IEC60601-2-37, Medical electrical equipment - Part 2-37:2007+AMD1:2015 Particular requirements for the basic safety and essential performance of ultrasonic medical diagnostic and monitoring equipment, International Electro technical Commission.
6. Roy C. Preston, David R. Bacon, and Robert A. Smith, Calibration of Medical Ultrasonic Equipment - Procedures and Accuracy Assessment, IEEE Transactions on Ultrasonics, Ferroelectrics, and Frequency Control, Vol. 35, No. 2, page110, March 1988.

B.8 Transducer Acoustic Output Data

Please refer to the User Manual Advanced Volume(P/N: 01.54.458510) for details acoustic output data of each transducer.

Appendix C Order List

The following accessories are recommended for use on the system.

WARNING

Only accessories supplied or recommended by EDAN can be used, the battery and transducers of EDAN can be only used on EDAN's systems. Otherwise, the performance and electric shock protection cannot be guaranteed. If electrical or mechanical equipment from other companies need to be connected to the device, please contact EDAN or authorized representatives before connection.

The following accessories are recommended for use on the ultrasound system.

<i>Part Name</i>	<i>Model</i>	<i>Part Number</i>
Ultrasonic Transducer	L17-7HQ	02.01.211856
	E8-4Q	02.01.214513
	C5-2Q	02.01.212622
	L12-5Q	02.01.212623
	L17-7SQ	02.01.211857
	MC8-4Q	02.01.212625
	P5-1Q	02.01.213916
	P7-3Q	02.01.214038
	MC9-3TQ	02.01.213995
	C7-2XQ	02.01.214827
	E10-3BQ	02.01.214793
	E10-3HQ	02.01.214791
	C6-2MQ	02.01.214776
C5-1Q	02.01.214783	
Needle Guide Bracket Kit	BGK-C5-2	02.01.211006
	BGK-CR10UA	02.01.102963
	BGK-002	02.01.215192
	BGK-003	02.01.215193

	BGK-004	02.01.215194
	BGK-005	02.01.215372
	BGK-006	02.01.215373
	BGK-007	02.01.215514
	BGK-008	02.01.215468
	BGK-009	02.01.215834
	BGK-012	02.01.216312
Power Cable, European Standard	FG-L23X-003-04	01.13.036638
Power Cable, American Standard	FG-L23X-20150323-001	01.13.037122
Lithium-Ion battery	TWSLB-018	01.21.064404
Ultrasound Gel	M-250B	01.57.078008
	Aquasonic 100	01.57.078001
USB Disk	/	01.18.052245
Footswitch(single button)	FS-81-SP-USB	01.10.000910
Fottswitch(doule button)	FS-81-SP(TWIN)-USB	01.10.027323

NOTE: The part name may vary depending on context, but the part number is constant.

Appendix D EMC Information

Electromagnetic emissions

Guidance and manufacture's declaration – electromagnetic emission		
The system is intended for use in the electromagnetic environment specified below; The customer or the user of the system should assure that it is used in such an environment.		
Emission test	Compliance	Electromagnetic environment – guidance
RF emissions CISPR 11	Group 1	The system is suitable for use in all establishments, other than domestic establishments and those directly connected to the public low-voltage power supply network that supplies buildings used for domestic purposes.
RF emissions CISPR 11	Class B	
Harmonic emissions IEC 61000-3-2	Class A	
Voltage fluctuations/flicker emissions IEC61000-3-3	Complies	

Electromagnetic immunity**Guidance and manufacture's declaration – electromagnetic immunity**


The system is intended for use in the electromagnetic environment specified below. The customer or the user of the system should assure that they are used in such an environment.

Immunity test	IEC/EN 60601 test level	Compliance level	Electromagnetic environment - guidance
Electrostatic discharge (ESD) IEC/EN 61000-4-2	± 8 kV contact ± 15 kV air	± 8 kV contact ± 15 kV air	Floors should be wood, concrete or ceramic tile. If floor are covered with synthetic material, the relative humidity should be at least 30%.
Electrical fast transient/burst IEC/EN 61000-4-4	±2 kV for power supply lines	±2kV for power supply lines	Mains power quality should be that of a typical commercial or hospital environment.
Surge IEC/EN 61000-4-5	±1 kV for line to line ±2 kV for line to ground	±1 kV for line to line ±2 kV for line to ground	Mains power quality should be that of a typical commercial or hospital environment.
Power frequency (50/60Hz) magnetic field IEC/EN 61000-4-8	30 A/m	30 A/m	Power frequency magnetic fields should be at levels characteristic of a typical location in a typical commercial or hospital environment.
Voltage dips, short interruptions and voltage variations on power supply input lines IEC/EN 61000-4-11	0 % U_T ; 0.5 cycle At 0°, 45°, 90°, 135°, 180°, 225°, 270° and 315° 0 % U_T ; 1 cycle and 70 % U_T ; 25/30 cycles) Single phase: at 0° 0 % U_T ; 250/300 cycle	0 % U_T ; 0.5 cycle At 0°, 45°, 90°, 135°, 180°, 225°, 270° and 315° 0 % U_T ; 1 cycle and 70 % U_T ; 25/30 cycles Single phase: at 0° 0 % U_T ; 250/300 cycle	Mains power quality should be that of a typical commercial or hospital environment. If the user of the system requires continued operation during power mains interruptions, it is recommended that the system be powered from an uninterruptible power supply or a battery.
NOTE U_T is the a.c. mains voltage prior to application of the test level.			

Electromagnetic immunity

Guidance and manufacture’s declaration – electromagnetic immunity

The system is intended for use in the electromagnetic environment specified below. The customer or the user of the system should assure that they are used in such an environment.

Immunity test	IEC/EN 60601 test level	Compliance level	Electromagnetic environment - guidance
<p>Conducted RF IEC/EN 61000-4-6 Radiated RF IEC/EN 61000-4-3</p>	<p>3 V_{rms} 150 kHz to 80 MHz 6V_{rms}^c in ISM bands between 0.15 MHz and 80 MHz 3 V/m 80 MHz to 2.7 GHz See table 1</p>	<p>3 V_{rms} 150 kHz to 80 MHz 6V_{rms}^c in ISM bands between 0.15 MHz and 80 MHz 3 V/m 80 MHz to 2.7 GHz Comply with table 1</p>	<p>Portable and mobile RF communications equipment should be used no closer to any part of the system, including cables, than the recommended separation distance calculated from the equation applicable to the frequency of the transmitter.</p> <p>Recommended separation distance</p> <p>$d = 1.2\sqrt{P}$ 150KHz to 80MHz</p> <p>$d = 1.2\sqrt{P}$ 80 MHz to 800 MHz</p> <p>$d = 2.3\sqrt{P}$ 800 MHz to 2.7 GHz</p> <p>$d = 6\sqrt{P/E}$ at RF wireless communications equipment bands (Portable RF communications equipment (including peripherals such as antenna cables and external antennas) should be used no closer than 30 cm (12 inches) to any part of the system, including cables specified by the manufacturer).</p> <p>Where P is the maximum output power rating of the transmitter in watts (W) according to the transmitter manufacturer and d is the recommended separation distance in meters (m).</p> <p>Field strengths from fixed RF transmitters, as determined by an electromagnetic site survey,^a should be less than the compliance level in each frequency range.^b</p> <p>Interference may occur in the vicinity of equipment marked with the following symbol:</p> 

NOTE 1 At 80 MHz and 800 MHz, the higher frequency range applies.

NOTE 2 These guidelines may not apply in all situations. Electromagnetic propagation is affected by absorption and reflection from structures, objects and people.

^a Field strengths from fixed transmitters, such as base stations for radio (cellular/cordless) telephones and land mobile radios, amateur radio, AM and FM radio broadcast and TV broadcast cannot be predicted theoretically with accuracy. To assess the electromagnetic environment due to fixed RF transmitters, an electromagnetic site survey should be considered. If the measured field strength in the location in which the system is used exceeds the applicable RF compliance level above, the system should be observed to verify normal operation. If abnormal performance is observed, additional measures may be necessary, such as reorienting or relocating the system.

^b Over the frequency range 150kHz to 80MHz, field strengths should be less than 3V/m.

^c The ISM (industrial, scientific and medical) bands between 0.15 MHz and 80 MHz are 6.765 MHz to 6.795 MHz; 13.553 MHz to 13.567 MHz; 26.957 MHz to 27.283 MHz; and 40.66 MHz to 40.70 MHz. The amateur radio bands between 0.15 MHz and 80 MHz are 1.8 MHz to 2.0 MHz, 3.5 MHz to 4.0 MHz, 5.3 MHz to 5.4 MHz, 7 MHz to 7.3 MHz, 10.1 MHz to 10.15 MHz, 14 MHz to 14.2 MHz, 18.07 MHz to 18.17 MHz, 21.0 MHz to 21.4 MHz, 24.89 MHz to 24.99 MHz, 28.0 MHz to 29.7 MHz and 50.0 MHz to 54.0 MHz.

Table 1 Test specifications for ENCLOSURE PORT IMMUNITY to RF wireless communications equipment

Test frequency (MHz)	Band ^{a)} (MHz)	Service ^{a)}	Modulation ^{b)}	Maximum power (W)	Distance (m)	Immunity test level (V/m)
385	380-390	TETRA 400	Pulse modulation ^{b)} 18 Hz	1.8	0.3	27
450	430-470	GMRS 460, FRS 460	FM ^{c)} ± 5 kHz deviation 1 kHz sine	2	0.3	28
710	704-787	LTE Band 13, 17	Pulse modulation ^{b)} 217 Hz	0.2	0.3	9
745						
780						
810	800-960	GSM 800/900, TETRA 800, iDEN 820, CDMA 850, LTE Band 5	Pulse modulation ^{b)} 18 Hz	2	0.3	28
870						
930						
1720	1700-1990	GSM 1800; CDMA 1900; GSM 1900; DECT; LTE Band 1, 3, 4, 25; UMTS	Pulse modulation ^{b)} 217 Hz	2	0.3	28
1845						
1970						

2450	2400-2570	Bluetooth, WLAN, 802.11 b/g/n, RFID 2450, LTE Band 7	Pulse modulation ^{b)} 217 Hz	2	0.3	28
5240	5100-5800	WLAN 802.11 a/n	Pulse modulation ^{b)} 217 Hz	0.2	0.3	9
5500						
5785						

NOTE If necessary to achieve the IMMUNITY TEST LEVEL, the distance between the transmitting antenna and the ME EQUIPMENT or ME SYSTEM may be reduced to 1 m. The 1 m test distance is permitted by IEC 61000-4-3.

- a) For some services, only the uplink frequencies are included.
b) The carrier shall be modulated using a 50 % duty cycle square wave signal.
c) As an alternative to FM modulation, 50 % pulse modulation at 18 Hz may be used because while it does not represent actual modulation, it would be worst case.

Recommended Separation Distances

Recommended separation distances between portable and mobile RF communications equipment and the system

The system is intended for use in an electromagnetic environment in which radiated RF disturbances are controlled. The customer or the user of the system can help prevent electromagnetic interference by maintaining a minimum distance between portable and mobile RF communications equipment (transmitters) and the system as recommended below, according to the maximum output power of the communications equipment.

Rated maximum output power of transmitter (W)	Separation distance according to frequency of transmitter(m)		
	150 kHz to 80 MHz $d = 1.2\sqrt{P}$	80 MHz to 800 MHz $d = 1.2\sqrt{P}$	800 MHz to 2.7 GHz $d = 2.3\sqrt{P}$
0.01	0.12	0.12	0.23
0.1	0.38	0.38	0.73
1	1.2	1.2	2.3
10	3.8	3.8	7.3
100	12	12	23

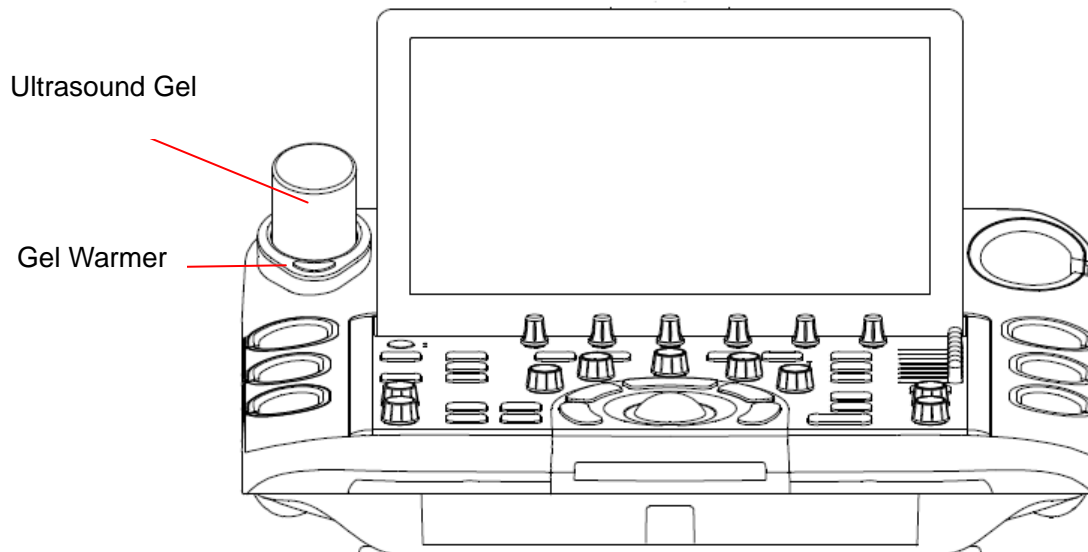
For transmitters rated at a maximum output power not listed above, the recommended separation distance d in meters (m) can be determined using the equation applicable to the frequency of the transmitter, where P is the maximum output power rating of the transmitter in watts (W) according to the transmitter manufacturer.

NOTE 1:At 80 MHz and 800 MHz, the separation distance for the higher frequency range applies.

NOTE 2:These guidelines may not apply in all situations. Electromagnetic propagation is affected by absorption and reflection from structures, objects and people.

Appendix E Ultrasound Gel Warmer

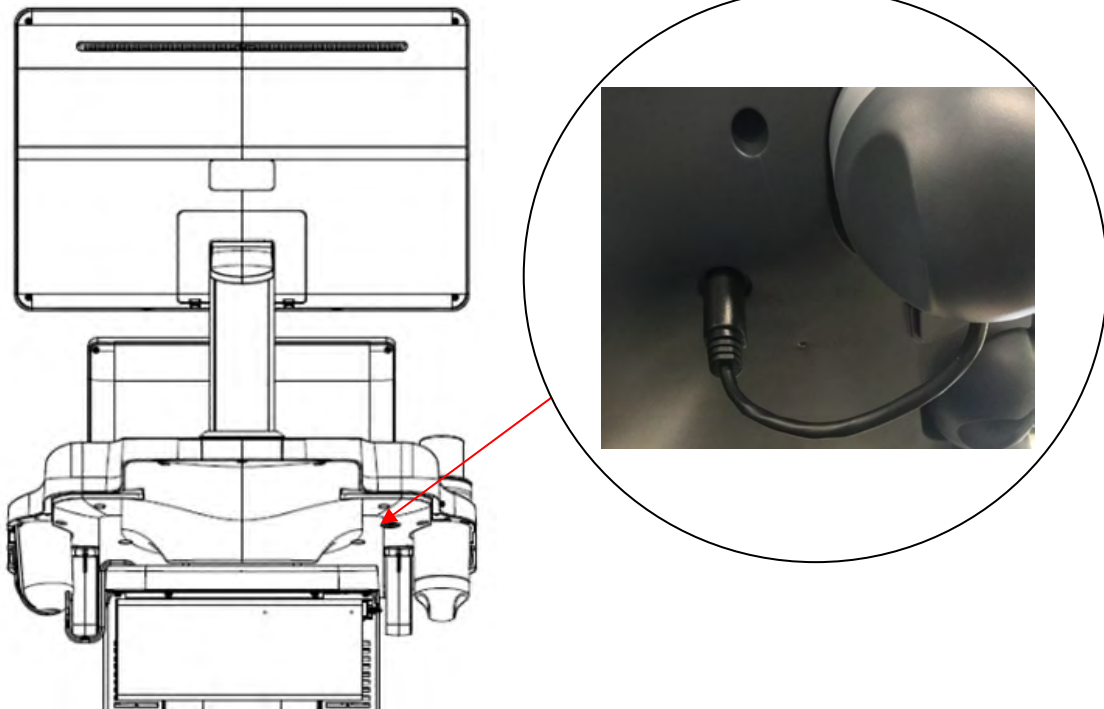
Ultrasound gel warmer is intended for heating the ultrasound gel. It is installed at the left upper corner of the control panel, as shown in the figure below.



To install gel warmer:

Put the gel warmer at the left corner of the control panel and connect the Power connector of gel warmer to the power socket on the below of control panel, as the figure shown below:



**To use gel warmer:**

After installing the gel warmer, put a bottle of ultrasound gel inside the gel warmer, and press the power switch on the gel warmer to start heating.

The gel warmer can heat the gel to about $36\pm 2^{\circ}\text{C}$. It will take about 0.5h to heating a bottle of 250ml ultrasound gel from 18°C to 28°C .

The gel warmer supports over-temperature protection and it can work continuously over 12 hours.

WARNING

1. When the over-temperature system of the gel warmer fails, the ultrasound system will display a prompt message "Gel heater is abnormal, there is overheating risk. Please stop using and contact the supplier for maintenance." In this case, you should switch off the gel warmer immediately and contact the service for maintenance.
2. Do not power on the gel warmer when no ultrasound gel is put inside, otherwise the gel warmer will be abnormal.
3. If you feel the gel is obviously too hot, please stop using it and contact the serviceman.
4. The gel warmer does not support "hot plug" feature. Please install the gel warmer before starting the ultrasound system. Otherwise the gel warmer may be unrecognized or works abnormally.

Note:

Do not spray any liquid on or into the gel warmer in use.

To clean gel warmer

1. Switch off the system and disconnect the gel warmer.
2. Rotate to remove the gel warmer bottom cover.
3. Use a sterile cloth dampened with cleaning agent to gently wipe the entire exterior surface(including the bottom cover) and inner surface of the warmer thoroughly until no visible contaminants remain.
4. After cleaning, wipe off the cleaning agent with a new sterile cloth dampened with tap water until no visible cleaning agent remains.
5. Leave the gel warmer air dry.

The validated cleaning agents for cleaning the gel warmer are:

- Ethanol (75%)
- Isopropanol (70%)

Note:

It is recommended to use the validated cleaning agents to clean the gel warmer. Do not use cloth with chemicals or use sharp-edged material (like steel wool) to clean the gel warmer.

P/N: 01.54.458509

MPN: 01.54.458509012



EDAN INSTRUMENTS, INC.

#15 Jinhui Road, Jinsha Community, Kengzi Sub-District
Pingshan District, 518122 Shenzhen, P.R.China

Email: info@edan.com

TEL: +86-755-2689 8326 FAX: +86-755-2689 8330

Website: www.edan.com

EC REPRESENTATIVE

Shanghai International Holding Corp. GmbH

Eiffestrasse 80, 20537 Hamburg Germany

TEL: +49-40-2513175

E-mail: shholding@hotmail.com