

ALXC28 User manual

User manual	1
1. Introduction.....	2
1.1 overview.....	2
1.2 Hardware Block Diagram	2
1.3 Interface	3
1.4 Package Info	3
1.5 PIN Description.....	4
2. Feature Highlights	4
2.1 Wi-Fi.....	4
2.2 Security.....	5
2.3 Network Connection Indication	5
3. Wi-Fi Specification	6
3.1 Wireless Specification.....	6
3.2 Tx Power	6
3.3 Rx Sensitivity.....	6

1. Introduction

1.1 overview

ALXC28 is a small size, low power consumption, dual band IEEE802.11 a/b/g/n WLAN module. It can provide network connection through SDIO, UART, SPI, PCM and other interfaces. The ALXC28 ,highly integrates MAC, Base band, RF, RF front end.



Figure 1 ALXC28 wifi module

1.2 Hardware Block Diagram

ALXC28 wifi module integrates a Wi-Fi BB/MAC/RF SoC and RF front end.

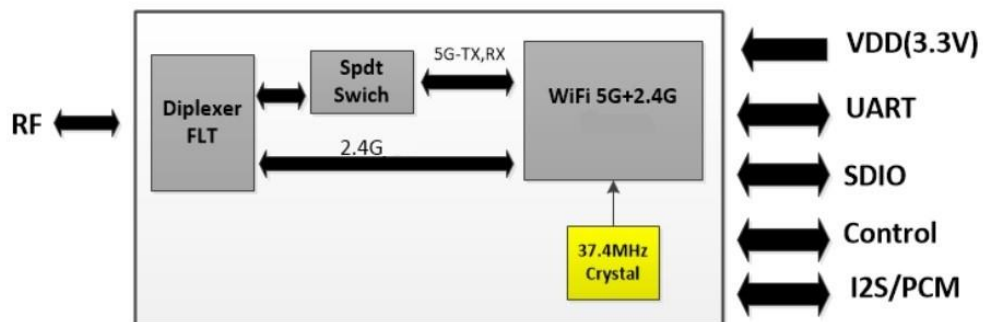

Figure 2 Block Diagram

1.3 Interface

The module includes various different host interfaces to communicate with Host CPU. Below table lists the basic descriptions of the Wi-Fi SoC and the interfaces.

Table 1 MCU and Interfaces

Model	ALXC28	
Wi-Fi Technology	IEEE802.11 a/b/g/n	
Frequency Band	2.4GHz & 5GHz, Dual Band	
Host Interfaces	UART x 1	Max 4Mbps
	SDIO x 1	SDIO 2.0, 25MHz & 50MHz, 1bit & 4bit mode
	I2S/PCM	16bit, 16KHz (256 kbps)

1.4 Package Info

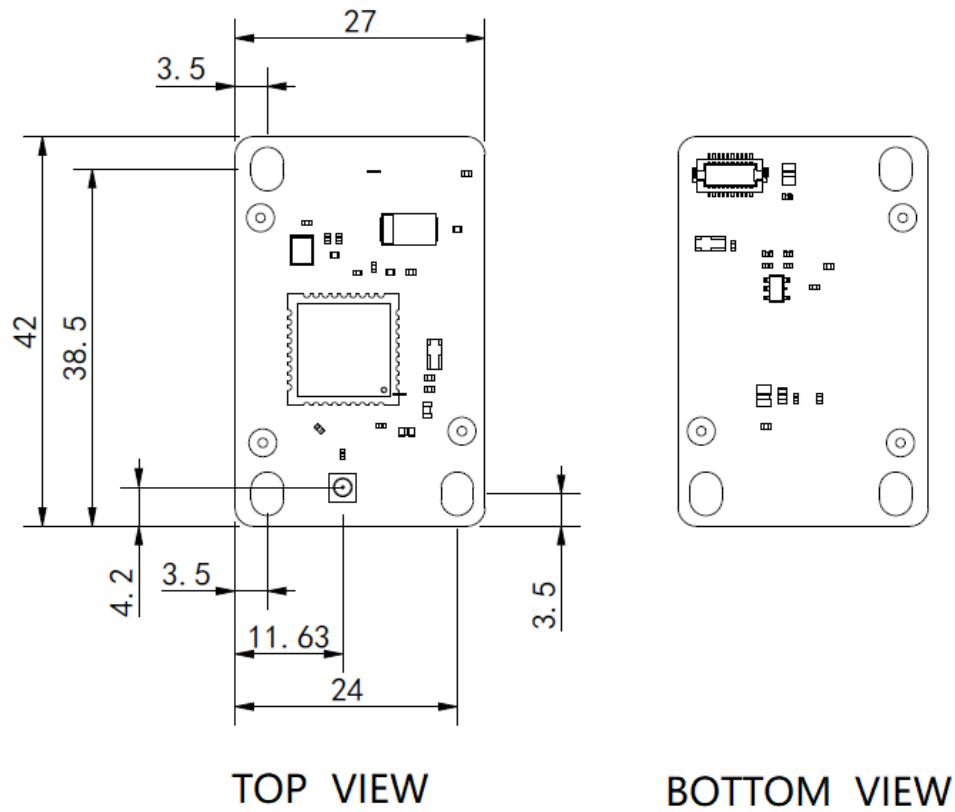

Table 2 Package info

1.5 PIN Description

Table 3 Pin Descriptions

No	Type	Name (main function)	Description	PIN connection (not use)
1	I/O	SDIO_CMD	SDIO command	
2	I	SDIO_CLK	SDIO clock input	
3	I/O	SDIO_DATA0	SDIO data0	
4	I/O	SDIO_DATA1	SDIO data 1	
5	I/O	SDIO_DATA2	SDIO data 2	
6	I/O	SDIO_DATA3	SDIO data 3	
7	I	WL_DEV_WAKE	WLAN device wakeup	Suspended
8	O	WL_HOST_WAKE	WLAN host wakeup	Suspended
9	S	GND	Ground	
10	O	BT_UART_RTS_N	UART request send	Suspended
11	I	BT_UART_CTS_N	UART clear send	Suspended
12	I	BT_UART_RXD	UART serial receiving	Suspended
13	O	BT_UART_TXD	UART serial transmitting	Suspended
14	I	EXT_SLEEP_CLK	External sleep clock (32.768kHz) or Ground	
15	O	BT_HOST_WAKE	Host wakeup	Suspended
16	I	BT_DEV_WAKE	Device wakeup	Suspended
17	S	GND	Ground	
18	I	BT_PCM_IN	PCM data in	Suspended
19	O	BT_PCM_OUT	PCM data out	Suspended
20	I/O	BT_PCM_CLK	PCM clock	Suspended
21	I/O	BT_PCM_SYNC	PCM sync	Suspended
22	I	BT_I2S_DI	I2C data in	Suspended
23	I/O	BT_PCM_WS	I2S WS	Suspended
24	I/O	BT_PCM_SCK	I2S clock	Suspended
25	O	BT_PCM_DO	I2S data out	Suspended
26	S	GND	Ground	
27	S	GND	Ground	
28	S	GND	Ground	
29	I/O	RFOUT	WLAN 5G,2.4GHz and Bluetooth RF input/output	
30	S	GND	Ground	
31	S	GND	Ground	
32	I	BT_REG_ON	BT power on/off	
33	I	WL_REG_ON	WLAN power on/off	
34	I	VBAT	SR VBAT and PAPMU VBAT power input	
35	I	VIO	1.8V-3.3V VDDIO input	
36	S	GND	Ground	
37	S	GND	Ground	
38	S	GND	Ground	
39	S	GND	Ground	
40	S	GND	Ground	

2. Feature Highlights

2.1 Wi-Fi

1. Dual-band 2.4 GHz and 5 GHz IEEE 802.11 a/b/g/n.
2. Single-stream IEEE 802.11n support for 20 MHz and 40 MHz channels provides PHY

layer rates up to 150 Mbps for typical upper-layer throughput in excess of 90 Mbps.

3. Supports the IEEE 802.11n STBC (space-time block coding) RX and LDPC (low-density parity check) TX options for improved range and power efficiency.

4. Supports IEEE 802.15.2 external coexistence interface to optimize bandwidth utilization with other co-located wireless technologies such as GPS, WiMAX, or UWB

5. Alternative host interface supports HSIC v1.0 (short-distance USB device)

2.2 Security

1. WPA™ and WPA2™ (Personal) support for powerful encryption and authentication

2. AES in WLAN hardware for faster data encryption and IEEE 802.11i compatibility

3. Reference WLAN subsystem provides Cisco® Compatible Extensions (CCX, CCX 2.0, CCX 3.0, CCX 4.0, CCX 5.0)

4. Reference WLAN subsystem provides Wi-Fi Protected Setup(WPS)

2.3 Network Connection Indication

Indications include:

- AP connecting
- AP connected
- AP disconnected
- Server connecting
- Server connected
- Server disconnected

3. Wi-Fi Specification

3.1 Wireless Specification

Table 4 2.4GHz Wireless Specification

Features		Specification
WLAN Standards		IEEE802.11 b/g/n
Antenna Port		1T/R
Frequency Band	11b	2412-2462 MHz
	11g/n 20MHz	2412-2462 MHz
	11n 40MHz	2422-2452 MHz
Modulation		DSSS(DBPSK,DQPSK,CCK), OFDM(BPSK,QPSK,16-QAM,64-QAM)
Link Data Rate	11b	1,2,5.5L,5.5S,11L,11S
	11g	6,9,12,18,24,36,48,54
	11n	MCS 0,1,2,3,4,5,6,7

Table 5 5GHz Wireless Specification

Features		Specification
WLAN Standards		IEEE802.11 a/n
Antenna Port		1T/R
Frequency Band	11a/n 20MHz	5180-5825 MHz
	11n 40MHz	5190-5795 MHz
Modulation		DSSS(DBPSK,DQPSK,CCK), OFDM(BPSK,QPSK,16-QAM,64-QAM)
Support data rates	11a	6,9,12,18,24,36,48,54
	11n	MCS 0,1,2,3,4,5,6,7

3.2 Rx Sensitivity

Table 6 2.4GHz Rx Sensitivity

Receiver Characteristics	TYP.	Unit
1 Mbps DSSS	-99	dBm
11 Mbps CCK	-89	dBm
54 Mbps OFDM	-77	dBm
MCS0 (20 MHz)	-92	dBm
MCS7 (20 MHz)	-73	dBm
MCS0 (40 MHz)	-89	dBm
MCS7 (40 MHz)	-69	dBm

Table 9 5GHz Rx Sensitivity

Receiver Characteristics	TYP.	Unit
6 Mbps DSSS	-90.5	dBm
54 Mbps OFDM	-73.5	dBm
MCS0 (20 MHz)	-90.5	dBm
MCS7 (20 MHz)	-70.5	dBm
MCS0 (40 MHz)	-87.5	dBm
MCS7 (40 MHz)	-68.5	dBm

Federal Communications Commission (FCC) Statement

This device complies with part 15 of the FCC Rules. Operation is subject to the following two conditions: (1) This device may not cause harmful interference, and (2) this device must accept any interference received, including interference that may cause undesired operation.

Note: This equipment has been tested and found to comply with the limits for a Class B digital device, pursuant to part 15 of the FCC Rules. These limits are designed to provide reasonable protection against harmful interference in a residential installation. This equipment generates, uses and can radiate radio frequency energy and, if not installed and used in accordance with the instructions, may cause harmful interference to radio communications. However, there is no guarantee that interference will not occur in a particular installation. If this equipment does cause harmful interference to radio or television reception, which can be determined by turning the equipment off and on, the user is encouraged to try to correct the interference by one or more of the following measures:

- Reorient or relocate the receiving antenna.
- Increase the separation between the equipment and receiver.
- Connect the equipment into an outlet on a circuit different from that to which the receiver is connected.
- Consult the dealer or an experienced radio/TV technician for help.

Warning: Changes or modifications made to this device not expressly approved by Edan Instruments, Inc. may void the FCC authorization to operate this device.

Note: The manufacturer is not responsible for any radio or TV interference caused by unauthorized modifications to this equipment. Such modifications could void the user's authority to operate the equipment.

RF exposure statement:

The transmitter must not be co-located or operated in conjunction with any other antenna or transmitter. This equipment complies with the FCC RF radiation exposure limits set forth for an uncontrolled environment. This equipment should be installed and operated with a Minimum distance of 20cm between the radiator and any part of your body.

This transmitter must not be co-located or operating in conjunction with any other antenna or transmitter. Country Code selection feature to be disabled for products marketed to the US/Canada.

This device is intended only for OEM integrators under the following conditions:

1. The antenna must be installed such that 20 cm is maintained between the antenna and users, and
2. The transmitter module may not be co-located with any other transmitter or antenna,
3. For all products market in US, OEM has to limit the operation channels in CH1 to CH11 for 2.4G band by supplied firmware programming tool. OEM shall not supply any tool or info to the end-user regarding to Regulatory Domain change. (if modular only test Channel 1-11)

As long as the three conditions above are met, further transmitter testing will not be required. However, the OEM integrator is still responsible for testing their end-product for any additional compliance requirements required with this module installed.

Important Note:

In the event that these conditions cannot be met (for example certain laptop configurations or co-location with another transmitter), then the FCC authorization is no longer considered valid and the FCC ID cannot be used on the final product. In these circumstances, the OEM integrator will be responsible for re-evaluating the end product (including the transmitter) and obtaining a separate FCC authorization.

End Product Labeling

The final end product must be labeled in a visible area with the following" Contains FCC ID: SMQXC28EDAN"

Manual Information to the End User

The OEM integrator has to be aware not to provide information to the end user regarding how to install or remove this RF module in the user's manual of the end product which integrates this module.

The end user manual shall include all required regulatory information/warning as show in this manual.

Integration instructions for host product manufacturers according to KDB 996369 D03 OEM Manual v01r01

2.2 List of applicable FCC rules

CFR 47 FCC PART 15 SUBPART C has been investigated. It is applicable to the modular transmitter

2.3 Specific operational use conditions

This module is stand-alone modular. If the end product will involve the Multiple simultaneously transmitting condition or different operational conditions for a stand-alone modular transmitter in a host, host manufacturer have to consult with module manufacturer for the installation method in end system.

2.4 Limited module procedures

Not applicable

2.5 Trace antenna designs

Not applicable

2.6 RF exposure considerations

This equipment complies with FCC radiation exposure limits set forth for an uncontrolled environment. This equipment should be installed and operated with minimum distance 20cm between the radiator & your body.

2.7 Antennas

This radio transmitter FCC ID:SMQXC28EDAN has been approved by Federal Communications Commission to operate with the antenna types listed below, with the maximum permissible gain indicated. Antenna types not included in this list that have a gain greater than the maximum gain indicated for any type listed are strictly prohibited for use with this device.

Type	Antenna type	Frequency Range	Antenna Gain
LBS-019C	FPC antenna	2.4GHz – 2.5 GHz	2.85 dBi
		5.15GHz – 5.85 GHz	3.46 dBi

2.8 Label and compliance information

The final end product must be labeled in a visible area with the following "Contains FCC ID:SMQXC28EDAN".

2.9 Information on test modes and additional testing requirements

Host manufacturer is strongly recommended to confirm compliance with FCC requirements for the transmitter when the module is installed in the host.

2.10 Additional testing, Part 15 Subpart B disclaimer

Host manufacturer is responsible for compliance of the host system with module installed with all other applicable requirements for the system such as Part 15 B.

2.11 Note EMI Considerations

Host manufacture is recommended to use D04 Module Integration Guide recommending as "best practice" RF design engineering testing and evaluation in case non-linear interactions generate additional non-compliant limits due to module placement to host components or properties.

2.12 How to make changes

This module is stand-alone modular. If the end product will involve the Multiple simultaneously transmitting condition or different operational conditions for a stand-alone modular transmitter in a host, host manufacturer have to consult with module manufacturer for the installation method in end system. According to the KDB 996369 D02 Q&A Q12, that a host manufacture only needs to do an evaluation (i.e., no C2PC required when no emission exceeds the limit of any individual device (including unintentional radiators) as a composite. The host manufacturer must fix any failure.