

HD16(RF)配 Mk10D（带 SER100）技术说明书

版本 Version	修改日期 Modification Date	修改说明 Description	修改人 Modified By	适用范围 Applicability Scope
V1.0	2016-05-15	初版 First Edition	李文科 Wenke Li (EDMI Shenzhen)	HD16(RF) For SER100 HD16_V1.0_S001
V1.1	2016-05-19	1、The last Credit Tokens 由 5 条增加为 10 条； 2、time/date of the last 10 credit tokens 3、kwh values from the last 10 credit tokens 4、the last 10 engineering tokens 5、time/date of the last 10 engineering tokens	李文科 Wenke Li	HD16(RF) For SER100 HD16_V1.0_S002
V1.2	2016-11-30	1、增加了低电量报警功能：当剩余电量低于 10kWh 的时候 Credit LED 常亮，蜂鸣器报警，长按 Enter 键可取消蜂鸣器报警。 2、增加了 RF 模块生产测试功能：短接 TP3 进入功率测试界面；键盘输入 2580 进入接收灵敏度测试界面。按 Back 键可退出测试界面。	安涛 AnTao	HD16(RF) For SER100 HD16_V1.0_S006
V1.3	2016-12-2	完善描述不清楚的地方：长按 Enter 键 1 秒钟可取消蜂鸣器报警。	安涛 AnTao	HD16(RF) For SER100 HD16_V1.0_S006
V1.4	2017-04-21	将发射功率改为 8dbm。	安涛 AnTao	HD16(RF) For SER100 HD16_V1.0_S008

目录 Table of Contents

1. 简介 Introduction	3
2. 外观、尺寸、液晶和安装图 External Features, Dimensions, Liquid Crystal and Installation Diagram	4
2.1 外观 External Features.....	4
2.2 液晶 Liquid Crystal	4
2.3 外观尺寸 External Appearance & Dimensions.....	5
2.4 安装尺寸及方式 Installation Dimensions & Method.....	5
3. 电气参数 Electrical Parameters	7
3.1 工作电压 Operating Voltage	7
3.2 工作电流 Operating Current	7
3.3 无线通讯参数 RF Communications Parameters	7
3.4 按键规格 Keys Specifications	7
3.5 显示规格 Display Specifications	7
3.6 工作环境 Operating Environment.....	7
3.7 接口 Interface	8
4. 按键定义 Keys Definitions	8
5. LED 指示、背光控制、LCD 显示以及蜂鸣器告警 LED Indicators, Backlight Control ,LCD Icons and Buzzer Alarm	9
6. 开机、关机、自动关机 Powered on and Power off and Auto Power Off	12
6.1 开机步骤 Power On Step 1: 初始化设备 Initialize the Device	12
6.2 开机步骤 Power On Step 2: 建立通讯 Establish the Communications.....	12
6.3 关机	12
7. 默认显示界面 Default Display Interface.....	13
8. HASH 界面 Interface	14
9. TOKEN 界面 Interface	15
10. 合闸功能 Relay Close	17
11. 序列号修改界面 Serial Setting Interface	18
12. 页面跳转 Page Changeover.....	19
13. 通讯流程 Communications Process/Flow	21
13.1 初始化通讯流程图 Initialization Communications Flowchart	21
13.2 HASH 通讯流程图 Communications Flowchart	23
13.3 Token 通讯流程图 Communications Flowchart	24
14. 电池和充电器 battery and charger.....	26
15. RF 模块生产测试功能 RF Module production test function	26
16. 注意事项 Notice.....	27
附录 1: 短码列表 Appendix 1: HASH Command Code List	27

1. 简介 Introduction

CIU(Customer Interface Unit)是配合电能表使用的用户界面单元，用户通过 CIU 查询电表的剩余电量、继电器状态等信息，并可输入 TOKEN 序列号，完成 TOKEN 功能。

CIU (Customer Interface Unit) is for use with electricity meter. Using this device, users may check the meter's energy balance (energy credits remaining), relay status and other information, input TOKEN serial number, and complete TOKEN's functionality.

本手册适用设备为 HD16(RF) ， 并配合电表 Mk10D 安装 SER100 RF modem 使用。

This manual is applicable to HD16(RF) equipment and for use with electricity meter SER100 RF modem

本手册的目标人员是：公司内部技术人员、工程人员、测试人员等，不建议直接提供给客户。

Target audience for this manual are: Technical, engineering, testing personnel, etc. This manual is not recommended to be given to customers (end-users).

本手册为相关人员提供该 CIU 设备的具体参数规格、操作方式，技术原理及流程。

This manual will provide the CIU's parameters, specifications, operation method, technical principle and process to the relevant personnel.

请按照目录顺序阅读本手册。

Please read this manual sequentially according to its Table of Contents.

2. 外观、尺寸、液晶和安装图

External Features, Dimensions, Liquid Crystal and Installation Diagram

2.1 外观 External Features

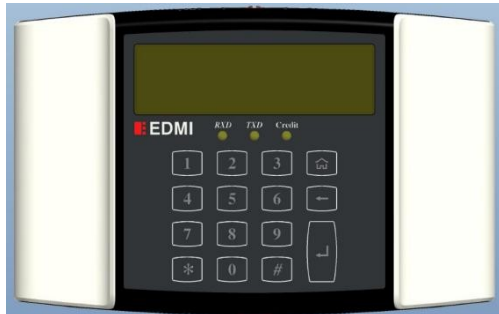

HD16 正面 Front View



HD16 底部 Base



HD16 背面 Back View

2.2 液晶 Liquid Crystal

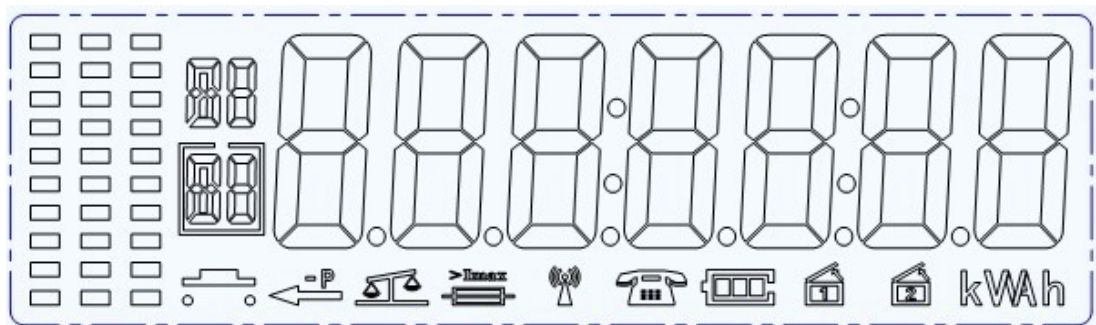

2.3 外观尺寸 External Appearance & Dimensions

HD16 实际尺寸 Actual Dimensions: 长 Length95mm、宽 Width149mm、厚 Depth29mm;

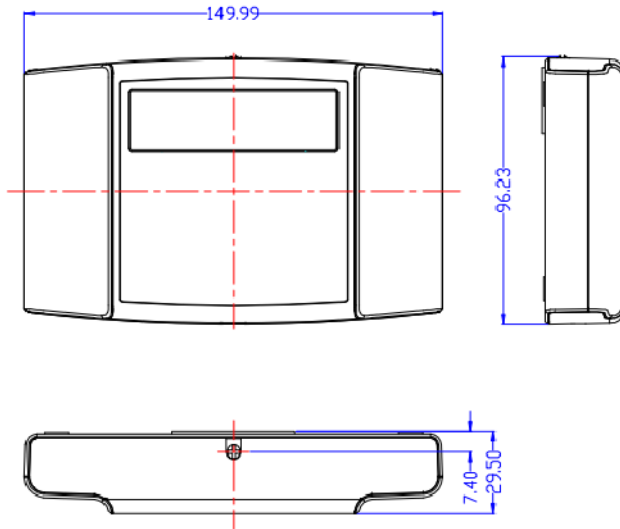

2.4 安装尺寸及方式 Installation Dimensions & Method

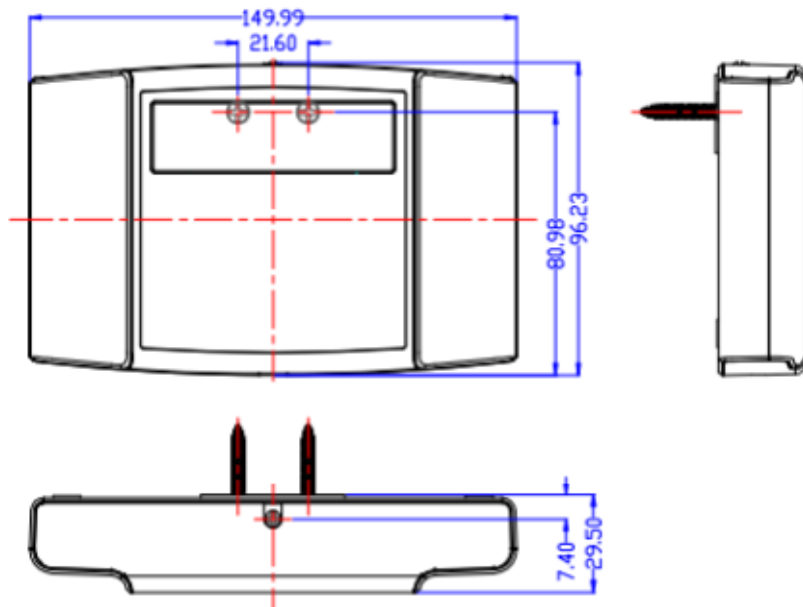

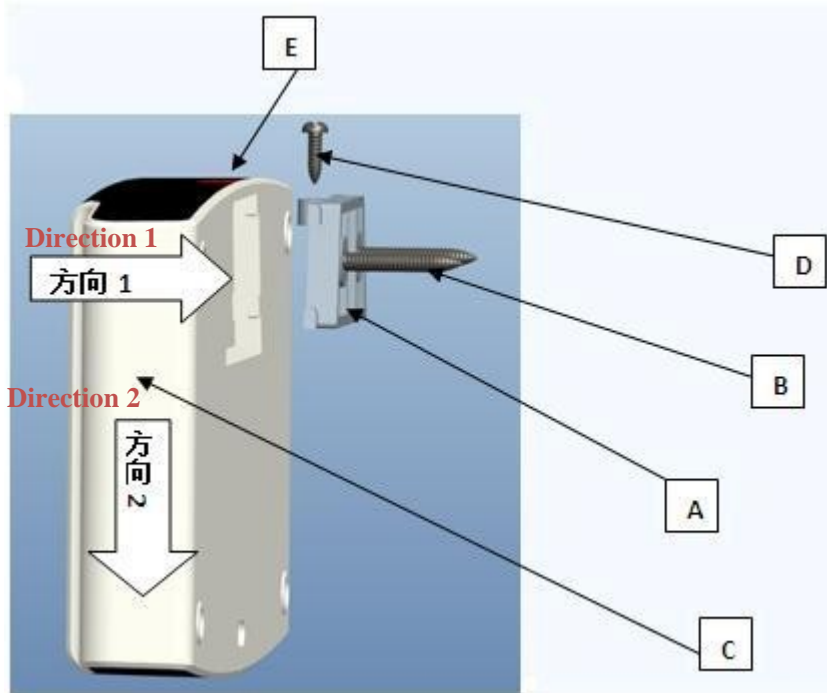

1) 用螺钉“B”，将挂钩“A”固定在墙壁上

Use a first screw (denoted as item B) to mount and secure CIU bracket (denoted as item A) to the wall.

2) 将 HD16 (“C”)，按照 (“方向 1”) 卡在 “A” 上

Next, move HD16 (denoted as item C) in the direction of “Direction 1” to place C’s back groove initially into top portion of CIU bracket (denoted as item A).

3) 将 HD16 (“C”)，按照 (“方向 2”) 卡紧

Next, move HD16 (denoted as item C) downwards in the direction of “Direction 2” to fit C securely on CIU bracket (denoted as item A).

4) 将螺钉“D”从“E”处锁紧“A”和“C”

Use a second screw (denoted as item D) to secure the CIU and CIU bracket (items A and C) at point E of CIU (top of CIU).

3. 电气参数 **Electrical Parameters**

3.1 工作电压 **Operating Voltage**

由锂电池供电，或者由 5V 直流适配器供电 Power by lithium battery or 5V DC

3.2 工作电流 **Operating Current**

1) 无通讯，LED 及背光全灭：<=24mA

When CIU is not communicating and LED and backlight are OFF (switched off): <=24mA

2) 有通讯，亮其中 2 个 LED，亮按键背光，亮 LCD 背光：60mA

When CIU is not communicating, 2 LEDs are ON (lit up), the pressed key's backlight is ON (lit up) and the LCD backlight is ON (lit up): Less than 60mA

3) 待机电流：小于 120uA

current less than 100uA in sleep model

3.3 无线通讯参数 **RF Communications Parameters**

无线频率：见 HD16 RF 规格 RF frequent: Check Manufacturing Codes

调制方式：FSK Modulation: FSK

发射功率：8dBm RF Power 8dBm

RF 频段：ISM 433MHz、915MHz，其它频段需定制； 通信速率：10Kbps、

38.4Kbps Communicate Rate 38.4Kbps 通讯距离：空旷距离 100m 以上

Communicate Distance: More than 100m

3.4 按键规格 **Keys Specifications**

使用电容式触摸按键 Capacitive-touch keys are used.

3.5 显示规格 **Display Specifications**

使用字段式液晶显示屏

黄色 LED 指示灯 1 个，绿色 LED 灯 1 个，红色 LED 灯 1 个

Character-segment LCD screen

Indicator LED light: 1 x yellow LED, 1 x green LED, 2 x red LED,

3.6 工作环境 **Operating Environment**

工作温度范围 Operating Temperature Range: $-10^{\circ}\text{C} \sim +45^{\circ}\text{C}$

存储温度范围 Storage Temperature Range: $-25^{\circ}\text{C} \sim +55^{\circ}\text{C}$

湿度范围 Humidity Range: <95% (无凝露 No condensation)

3.7 接口 **Interface**

使用 Micro USB

4. 按键定义 **Keys Definitions**

0~9: 数字键 **Number Keys**



“Power” 键用于开机关机 **power key: use for Power and Power off**



“back” 键 **key** (用于 **Used for:** 删除 **Deletion**、退出 **exiting program**)



“enter” 键 **key** (用于 **Used for:** 确认数字输入 **Confirming User's inputs**)



“*” 键 **key** (用于 **Used for:** 向下翻页 **page down**)



“#” 键 **key** (用于 **Used for:** 向上翻页 **page up**)

5. LED 指示、背光控制、LCD 显示以及蜂鸣器告警 LED Indicators, Backlight Control ,LCD Icons and Buzzer Alarm

如下图，为 LCD 全显内容，HD16 在开机时 LCD 全显





LCD will display all segment when HD16 starting up







如下表所示，为 LCD 图标及 LED 指示说明

LCD icons and LED indicator description are as shown in the tables below:

LED 与背光指示 LED / Backlight Controls	说明 Description
Credit	此 LED 常亮表示：剩余电量≤10 kWh When this LED is permanently ON (lit up), it indicates Energy Credits Remaining (Current Energy Balance)≤10 kWh
RXD	此 LED 亮 200ms 表示：接收到一帧数据，且解析正确 When this LED is ON (lit up) for 200ms, it indicates CIU is receiving a frame and parsing the frame correctly.
TXD	此 LED 亮 200ms 表示：发送一帧数据时 When this LED is ON (lit up) for 200ms, it indicates CIU is transmitting a frame.
KEY 与 LCD 背光 (KEY backlight and LCD backlight)	有按键触发时点亮，无按键触发 30s 后关闭 When a key is touched, these backlights are ON (lit up) for 30s, then they are OFF (switched off).

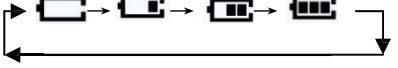
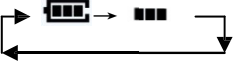
LCD 图标及指示 LCD Display Icon & Indicator	说明 Description	
	此图标显示表示：与电表成功建立通讯 This icon is displayed to indicate CIU has established communications with the Meter successfully.	
	此图标显示表示：正在与电表通讯 This icon is displayed to indicate CIU is communicating with the Meter now.	
	格数 Bars	电池电量 battery level
	0 	0~5%
	1 	5%~25%

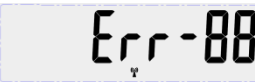
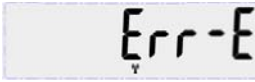
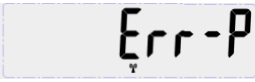
LCD 图标及指示 LCD Display Icon & Indicator	说明 Description	
	2 	25%~75%
	3 	75%~100%
		HD16 由电源适配器充电 HD16 charge by 5V DC
		电池已经充满 The battery of HD16 is full
kVAh	电量，电压，电流，功率单位 This Unit of Measurement (UOM) icon changes according to the electrical quantity (Energy, Voltage, Current or Power) that is being displayed on the LCD as explained below:	
	kWh	电量单位 This icon is displayed to indicate unit of Energy is kilo Watt-hour.
	kW	功率单位 This icon is displayed to indicate unit of Power is kilo Watt. For example, this is the nit for “Instantaneous (Active)Power” 当前有功功率 in Tanzania, Malaysia and Post-pay menus.
	W	功率单位 This icon is displayed to indicate unit of Power is Watt. For example, this is the Unit for “Maximum Power Limit (MPL)/ Load Limit”最大功率限值 in Tanzania menu.
	A	电流单位 This icon is displayed to indicate unit of Current is Ampere.
	V	电压单位 This icon is displayed to indicate unit of Voltage is Volts.
	等待状态 This icon is displayed to indicate CIU fails to communicate with Meter and goes into Waiting mode.	
	表示读取的内容是空的 This icon is displayed to indicate the content read by CIU is empty; or no such data item.	
	表示通讯失败 This icon is displayed to indicate communications has failed.	
	表示写 EEPROM 失败。 This icon indicates that writing to EEPROM has failed.	
	开机时没有检查到按键模块 This icon is displayed to indicate CIU fails to detect its Key-pressing module during CIU’s powering on.	

LCD 图标及指示 LCD Display Icon & Indicator	说明 Description

蜂鸣器告警 Buzzer Alarm	说明 Description
蜂鸣器每 10 秒响一次，每次持续 1 秒 The buzzer alarm 1 second every 10 second	当剩余电量低于剩余电量告警阈值时，蜂鸣器告警，长按“ENTER”键 1 秒钟可取消告警。 The buzzer will alarm if the Energy Credits Remaining falls below the Alarm-off Threshold, Long press “ENTER”key for 1 second to cancel the alarm

6. 开机、关机、自动关机 **Powered on and Power off and Auto Power Off**

长按  键开机或者关机 HD16 will Power On or Power off by Press the key for long
如果电池电压太低可能导致无法开机，需要接上 5v 电源适配器对电池进行充电
If the battery level low, the HD16 would not Power On, and the HD16 need to Power by 5V DC

6.1 开机步骤 **Power OnStep1: 初始化设备 Initialize the Device**

LCD: LCD 全显 All segments are ON (lit up)

LED: LED 轮流亮灭，每个 LED 亮 0.5s

LEDs take turns to be ON (lit up) and OFF (switched off); Each LED is lit for 0.5s.

LCD 背光与 KEY 背光: 亮

LCD backlight and KEY's backlight: Lit (ON)

此过程持续 1.5 秒

This process lasts for 1.5 seconds

如下图所示，为 LCD 上电全显:

LCD's all segments are ON (lit up) when Meter is powered on – as indicated in the diagram below:

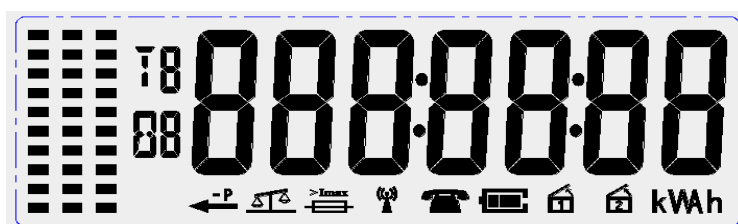

6.2 开机步骤 **Power onStep 2: 建立通讯 Establish the Communications**

此时 LCD 显示 During this period, the LCD displays:

- 1) 主屏显示 Main screen displays “-----”



6.3 关机

长按  可关机，press this key for long can power off HD16

或者在以下条件全部满足的情况下自动关机: HD16 will power off auto in bellow condition

- 1) 1 分钟内无按键操作 no key pressed in 1 minute
- 2) 1 分钟内无通讯动作 (在默认显示界面除外) RF do not work in 1 minute

7. 默认显示界面 Default Display Interface

序号 Item No.	显示屏 Display Screen	显示内容说明 Explanation of Displayed Content
1		第 01 屏 No. 01 Screen 显示剩余电量:-0.01kWh Credits Remaining is -0.01kWh
2		第 02 屏 No. 02 Screen 显示电表序列号 211493090 Meter Serial Number is 211493090
3		第 03 屏 No. 03 Screen 显示继电器状态 rELay-y: 继电器合闸 relay close rELay-n: 继电器拉闸 relay open

此界面按键功能:

In this interface, the key-pressed functions are:

- 1) 数字键: 可输入 HASH 码、token、密码(用于配置 HD16)
Numeric keys: Use these keys for inputting HASH code, token, and password(for configuration HD16).
 - 2) *键: 可翻到下一个按键显示项
* key:Use this key to flip (change) display to the next display item of key-pressed menu.
 - 3) #键 key: 可翻到上一个按键显示项 Use this key to flip (change) display to the previous display item.
- 1) ←Back 键 key: 不可用 Not used
 - 2) ↵Enter 键 key: 确认数字输入 Use this key to confirm the input of numbers.

8. HASH 界面 Interface

输入 1~2 位数字，然后按“确认”键，可进入 HASH 界面

Input 1 or 2 numbers and press “ENTER” Key, get into the HASH interface

此界面 LCD 显示:

In this interface, the LCD displays:

- 1) 主屏: 显示 HASH 项
Main Screen displays the HASH item.
- 2) 左下角数字: 显示 HASH 号
Number displayed at the lower left corner is HASH Number
- 3) **kWh** 单位: 显示对应 **kWh** 单位
kWh unit icon: Displays the Unit of measurement that corresponds to the electrical quantity that is currently displayed.

此界面按键功能:

In this interface, the key-pressed functions are:

- 1) 数字键: 可输入 HASH 码、token、密码
Numeric keys: Use these keys for inputting HASH code, token, and password.
- 2) *键 key: 不可用 Not used
- 3) #键 key: 不可用 Not used
- 4) ←Back 键 key: 返回到“菜单显示界面”
Return to “Menu Display Interface”.
- 5) ↵Enter 键 key: 确认数字输入 Use this key to confirm the input of numbers.

如下图所示，为 HASH 命令 08 时 HD16 的 LCD 显示

Example: Input Hash command “08” and press “ENTER” key on HD16, LCD will display as follow

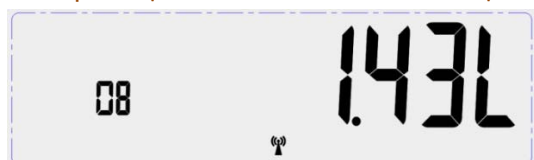

9. TOKEN 界面 Interface

输入 20 位数字，然后按“确认”键，可进入 token 界面

Input 20 numbers and press “ENTER” Key, get into the token interface

此界面 LCD 显示:

In this interface, the LCD displays:



- 1) 主屏: 显示输入数字
Main Screen displays the numbers that are input.
- 2) 左下角数字: 显示输入数字个数
Number displayed at the lower left corner is the length of numeric input (i.e. the number of digits input so far)

此界面按键功能:

In this interface, the key-pressed functions are:

- 1) 数字键: 不可用
Numeric keys: Not used
- 2) *键 key: 不可用 Not used
- 3) #键 key: 不可用 Not used
- 4) ←Back 键 key:
返回到“菜单显示界面”,如果正在进行传输 token 码的通讯,就中断这个通讯,重新输入数字
Return to “Menu Display Interface”. If token transmission process is interrupted, user needs to re-input the token (numbers).
- 5) ↵Enter 键 key: 不可用 Not used

token 结果显示

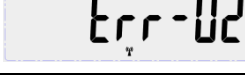
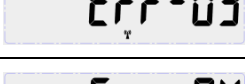
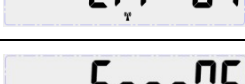
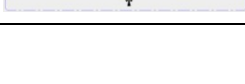
显示 Display Code	说明 Explanation
	充值成功 Energy replenishment/ top-up is successful (Energy units are incremented).
	Authentication failed
	Validation failed
	Token is older than the oldest token in the meter
	Token has already been used in this meter
	Meter key has expired

显示 Display Code	说明 Explanation
Err-07	Overflow in Credit Balance
Err-08	Token had an error except for overflow, 1stKCT, 2ndKCT
1KctEnt	First Key Change Token (1stKCT) has been entered
2KctEnt	Second Key Change Token (2ndKCT) has been entered
Err-88	通讯中断导致充值失败 Communications link failure (timeout) causes energy replenishment/ top-up to fail.

10. 合闸功能 Relay Close

1) 在“菜单显示”界面下，长按“确认”键，HD16 显示“1-CLOSE”

1) In “Menu Display Interface” Press“ENTER” Key for long, HD16 will display “1-CLOSE”



2) 按数字键“1”，HD16 显示“0-ESC10”最后 2 位数字显示倒计时，在倒计时未结束前，按数字键“0”终止倒计时

2) Press number key “1” HD16 display “0-ESC10”, The last 2 numbers count down, Press number key “0” would stop the numbers count down before it count to 0.



3) 倒计时结束后，HD16 显示“CLoSing”，并且对电表写入合闸命令，然后读取继电器状态，如果合闸显示“ya”，如果未合闸显示“no”

3) HD16 display “CLoSing” when the numbers count to 0, HD16 send command to close the relay of meter, then read the relay status of meter.

if relay close HD16 will display “ya”, if relay not close HD16 will display “no”.



11 序列号修改界面 **Serial Setting Interface**

输入密码“755204”后，按“ENTER”键，进入序列号修改界面

Input numbers “755204” and press “ENTER” key, get into the serial setting interface 输入的数字个数受限制，不可超过 9 个，输入数字完成后，按 ENTER 键可以保存序列号，保存序列号成功 LCD 显示 ya，保存失败显示 “Err-E”

The number input numbers is limited not more than 9, Press “ENTER” key will ensure the serial LCD will display “ya” if store the serial success, or display “Err-E”

注意 Notice

1) 如果 HD16 未被设置过序列号，或者设置的序列号为“000000000”，HD16 开机会进入序列号修改界面

1) If HD16 never be setting serial number, or the serial number set to “000000000”, HD16 will get into “Serial Setting Interface when startup”

2) 退出序列号修改界面时，HD16 会重新初始化

2) HD16 will initialize when exit “Serial Setting Interface”

12. 页面跳转 Page Changeover

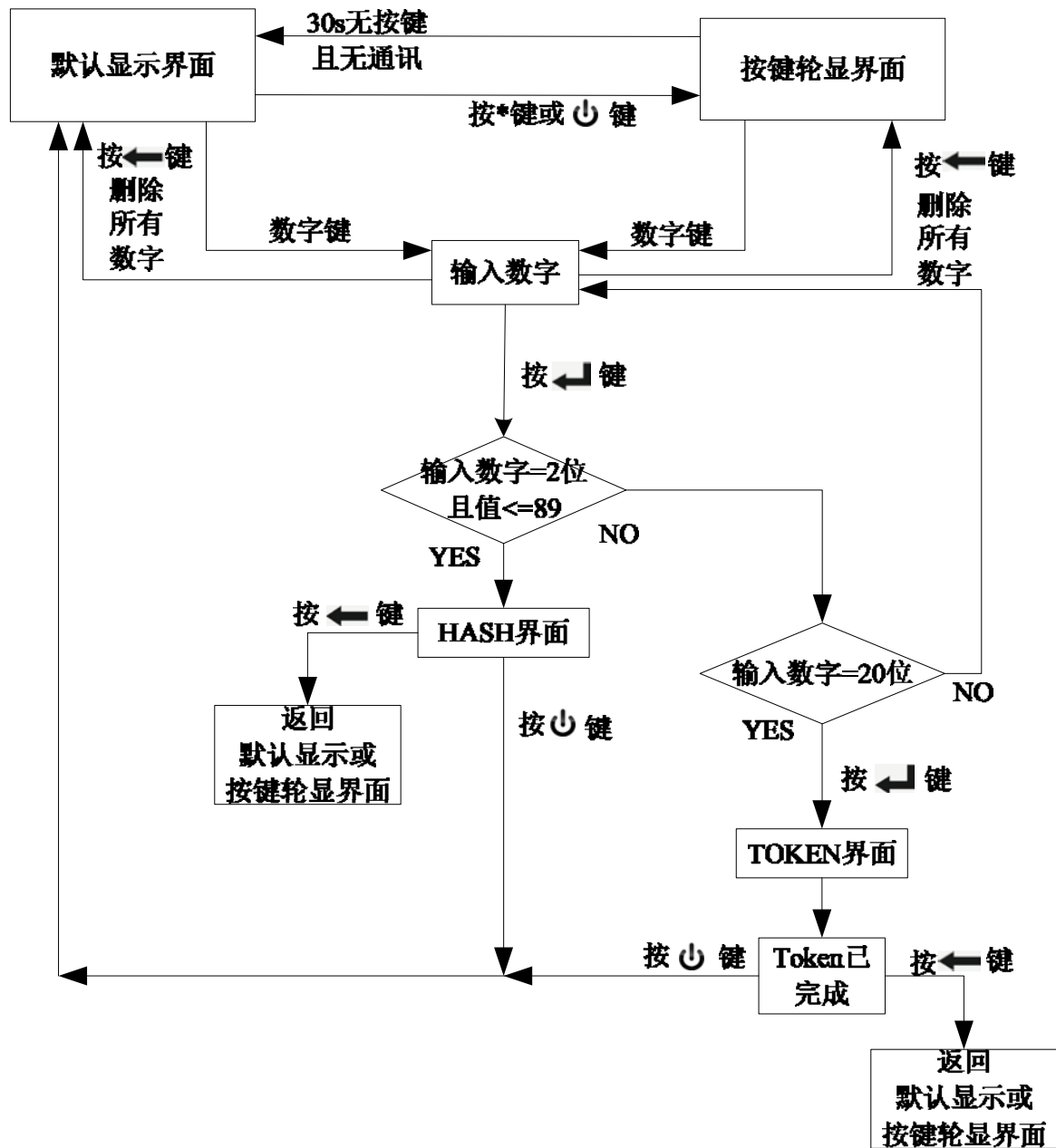

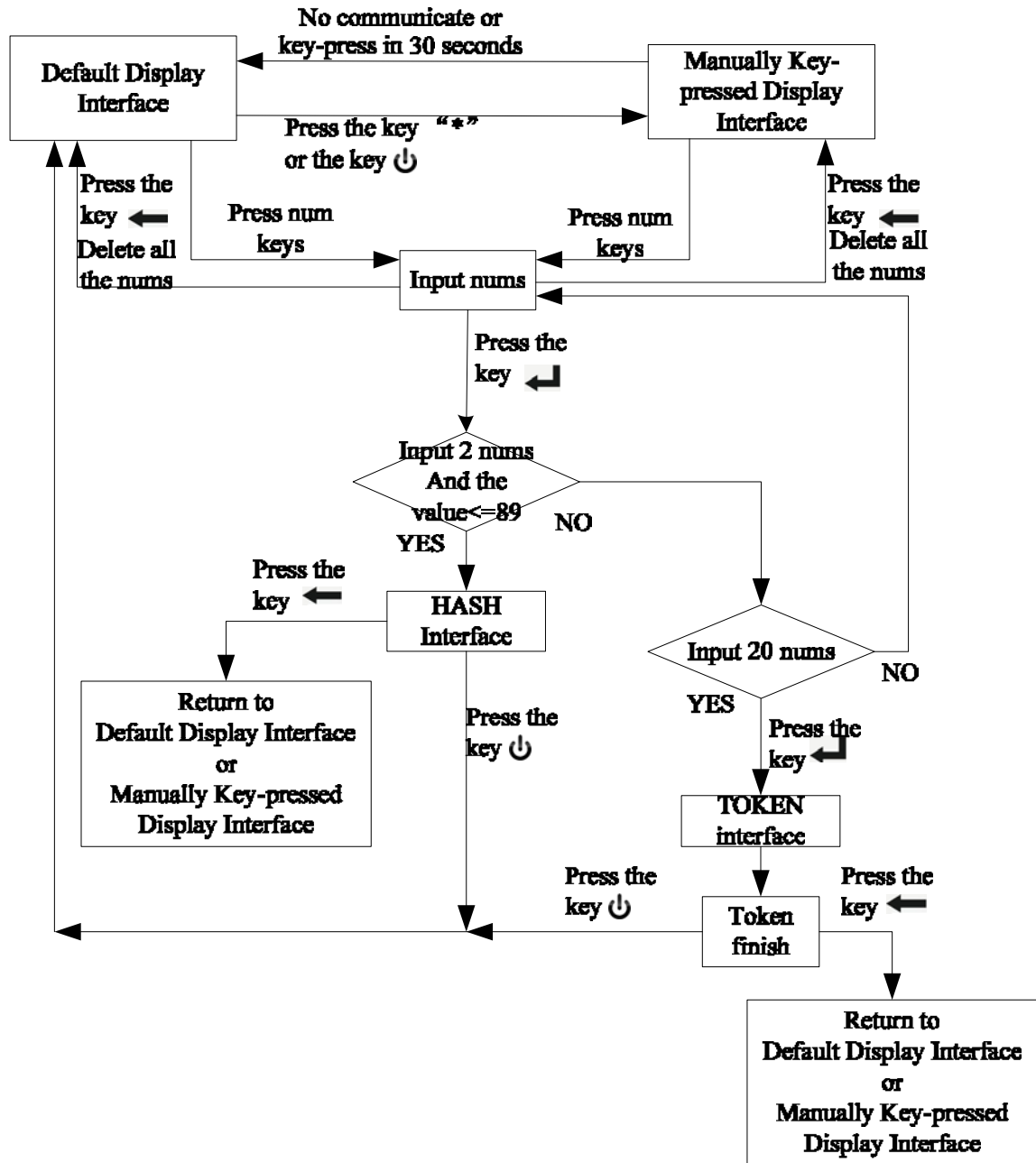

13. 通讯流程 Communications Process/Flow

13.1 初始化通讯流程图 Initialization Communications Flowchart

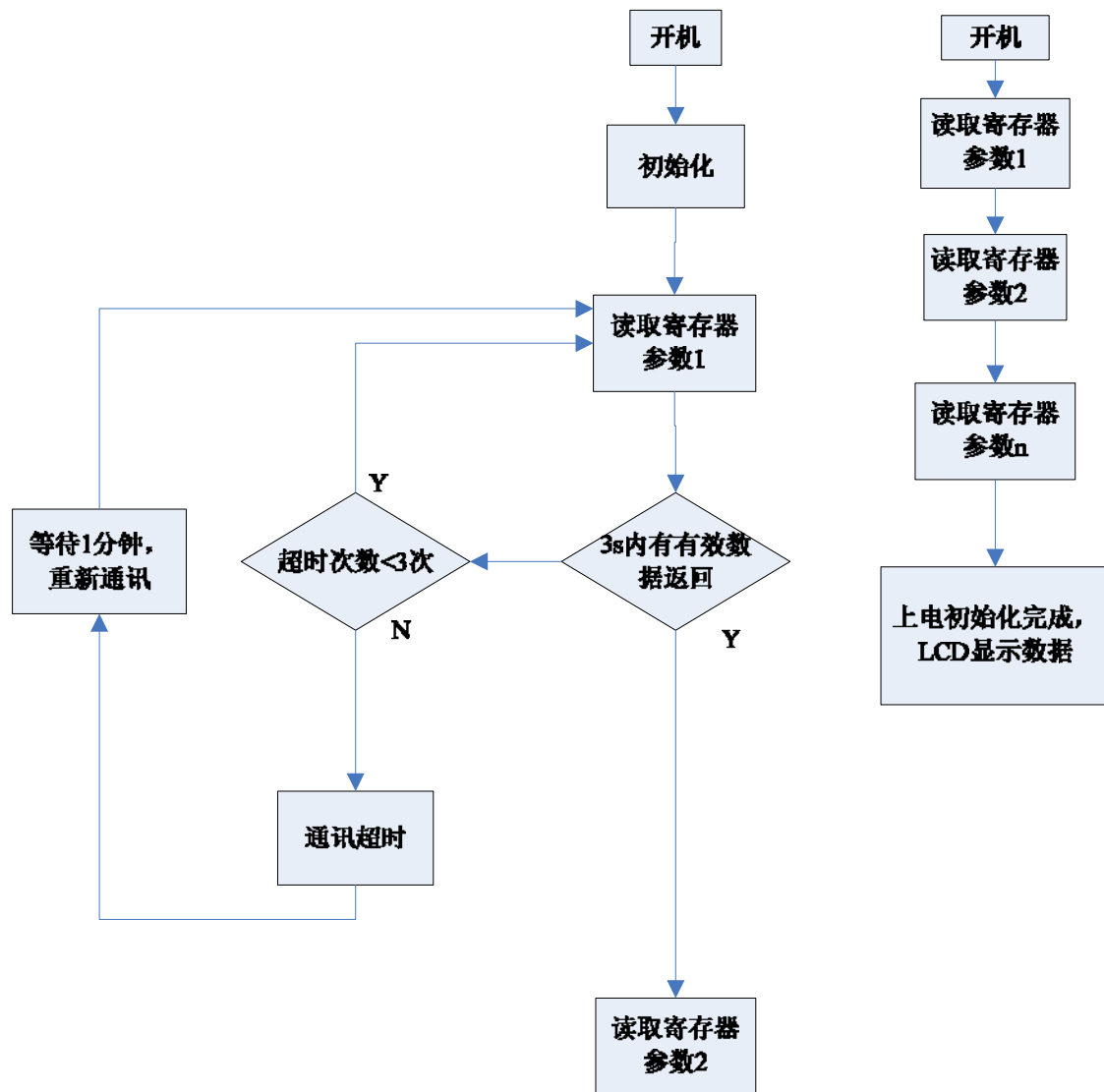

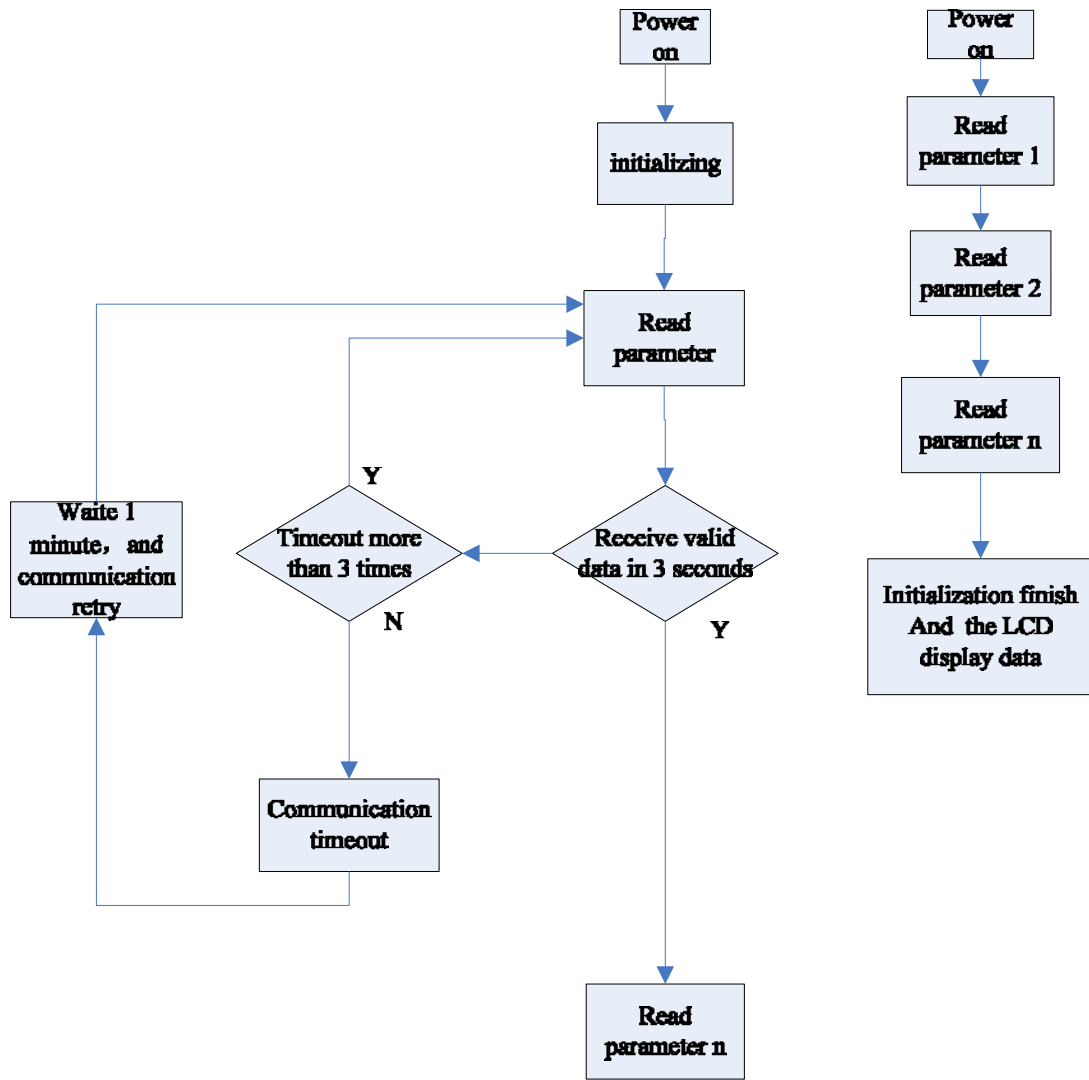

13.2 HASH 通讯流程图 Communications Flowchart

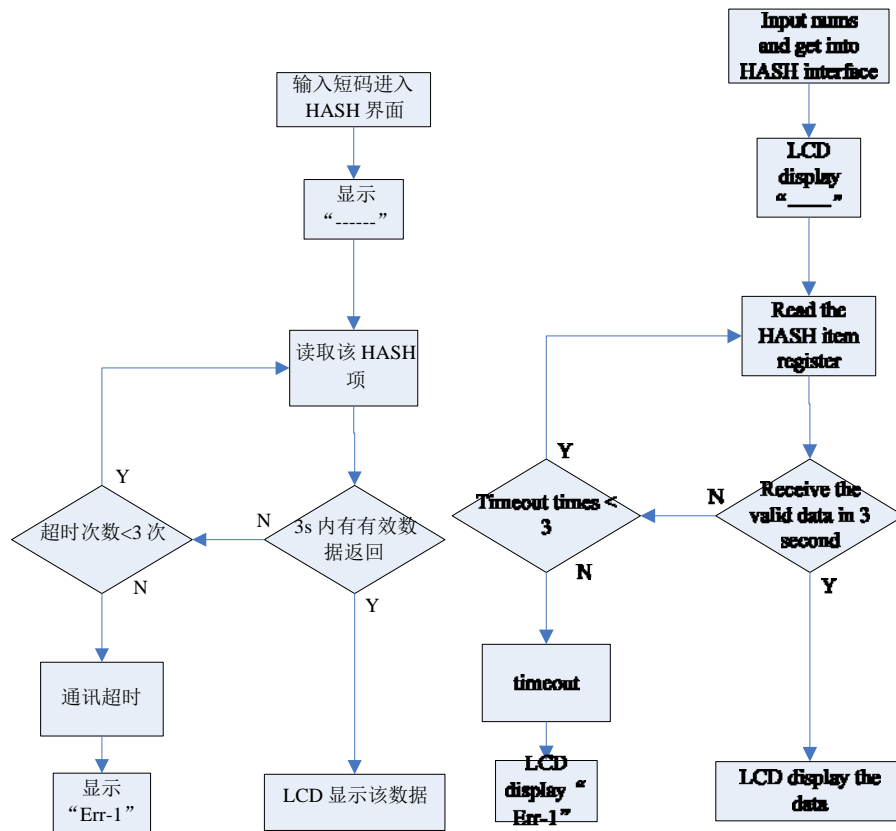

13.3 Token 通讯流程图 Communications Flowchart

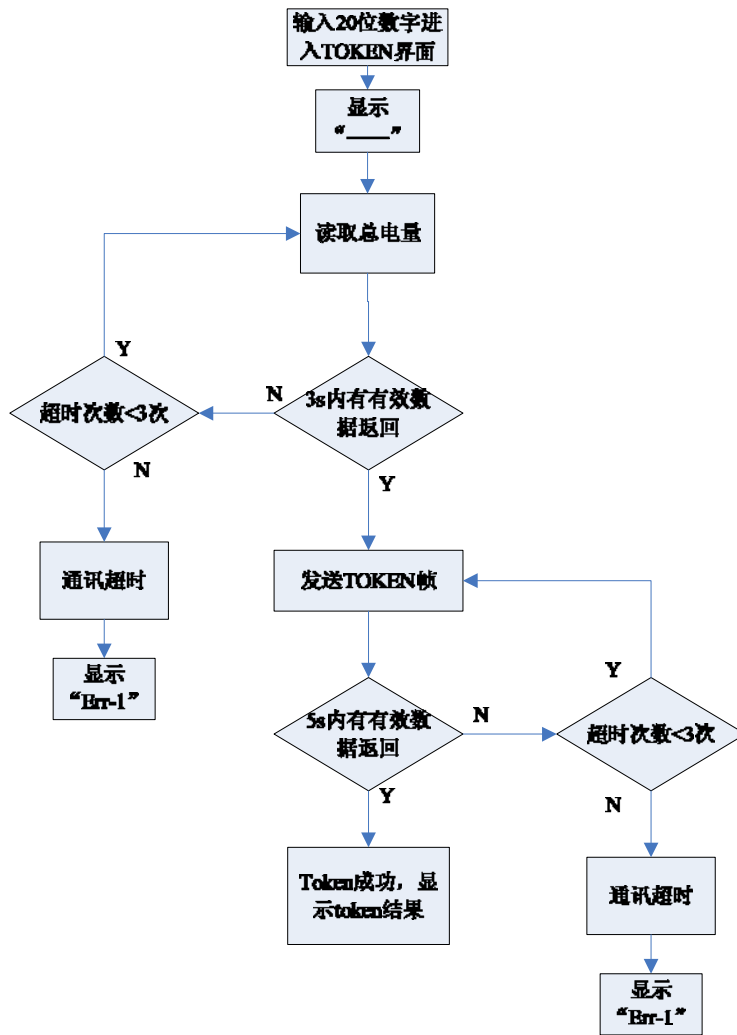

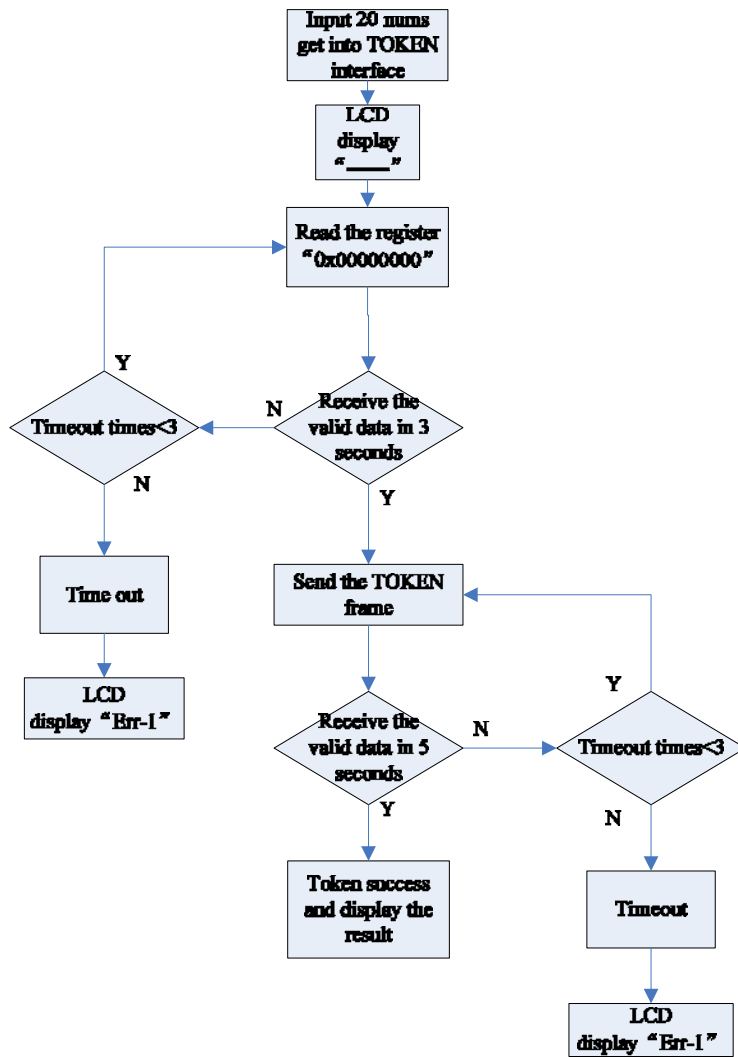

14 电池和充电器 battery and charger

电池：HD16(RF)内置 500mAh 或者 1000mAh 可充电式锂电池，充电次数约为 300 次。

Battery: HD16(RF) have 500mAh or 1000mAh battery inside, the battery can be charged 300 cycles

充电器：需满足以下要求: The charger should content requirements as bellow:

输出电压：DC 5V 输出电流：根据电池容量 300mA 以上或者 500mA 以上

Output voltage: DC 5V; Output current: more than 300mA or 500mA (according to battery volume)

符合当地对充电器的要求 in accordance with local requirements.

以下为某一种充电器的参数： One charger for HD16 as bellow:

输入 Input: AC 100~240V / 50~60HZ /150mA Max

输出 Output: DC 5V / 1.2A

充电器外观如下图: The charger appearance as follow



15.RF 模块生产测试功能 RF Module production test function

当将测试点 TP3 短接到地的时候，HD16 进入功率测试界面，此时可通过频谱仪观察波形判断发送功率，2 分钟后自动退出或按 Back 键退出功率测试界面。

When the test point TP3 short received, HD16 into the power test interface, this time can be measured by spectrum analyzer to determine the transmission power, after 2 minutes or press the Back key to exit the power test interface.

通过键盘输入 2580，HD16 可以进入接收灵敏度测试界面，此时当 RF 模块收到数据，都会通过串口发送出来，2 分钟后自动退出或按 Back 键退出接收灵敏度测试界面。

Through the keyboard input 2580, HD16 can enter the receiver sensitivity test interface, when the RF module receives the data that will be sent out through the serial port, after 2 minutes or press the Back key to exit the receiver sensitivity test interface.

16. 注意事项 Notice

HD16 按键板，如果受到强烈静电干扰，会导致某一按键一直触发，此按键 ic 有自动调整功能，大约 15s 后会自动对此按键进行调整，调整后按键可重新正常工作。

If HD16's keypad encounters strong electrostatic interference, it may cause one key (button) to be triggered continually.

HD16's key (button) IC has automatic adjustment function: After about 15s, the IC will do auto-adjustment to this key (button). After adjustment, this key (button) will function normally again).

如果一直按住某一按键大约 15s，将会触发此 IC 的自动调整功能，会导致 15s 内该按键无法触发的现象，如果出现此现象，请等待约 15s。

If any key (button) is pressed (held down) continually for about 15s, the automatic adjustment function by HD16's key (button) IC will be triggered. User may find that this key (button) cannot be triggered meanwhile (i.e. within this about 15s period).

So if this phenomenon occurs, please wait for 15s.

附录 1: 短码列表 Appendix 1: HASH Command Code List

HASH	Register	Register Number	Data Type	Example Value	Unit
1	Present Average Power in kW	E033	Float	2.57	kW
2	Total User Consumption to Date	1E00 (Assuming TOU ch1)	Float	78.37	kWh
4	Meter Serial Number	F002	Char(11)	"12345678901"	
5	CIU software version	CIU feature		V1.0S002	
6	Total user credit entered to Date	F04B	Float	-0.10	kWh
8	Meter Software version	F003	String	1.43L	
9	Wh per pulse	FF30	Float	0.2	Wh
10	Tariff index no.	F202	Byte	1	
11	Load limit(kW) token value	F233	Long	0.00	kW
12	Power purchase token of last time	F220	String	1892322345 2304456000	
13	Power purchase token of last 2nd time	F221	String	1892322345 2304456000	
14	Power purchase token of last 3rd time	F222	String	1892322345 2304456000	
15	Power purchase token of last 4th time	F223	String	1892322345 2304456000	
16	Power purchase token of last 5th time	F224	String	1892322345 2304456000	

17	Time and date of last valid token loaded	F225	Data	2011-08-27 14:15:27	s
18	Time and date of last 2 nd valid token loaded	F226	Data	2011-08-27 14:15:27	s
19	Time and date of last 3 rd valid token loaded	F227	Data	2011-08-27 14:15:27	s
20	Time and date of last 4 th valid token loaded	F228	Data	2011-08-27 14:15:27	s
21	Time and date of last 5 th valid token loaded	F229	Data	2011-08-27 14:15:27	s
22	Amount purchased last time	F22A	Long	4.50	kWh
23	Amount purchased last 2nd time	F22B	Long	3.70	kWh
24	Amount purchased last 3rd time	F22C	Long	5.20	kWh
25	Amount purchased last 4th time	F22D	Long	20.00	kWh
26	Amount purchased last 5th time	F22E	Long	10.00	kWh
27	Occurrence time of last power off event	FC20	Time/Date	2011-08-27 14:15:27	s
28	Date and time of last tariff index change	F230	Time/Date	2011-08-27 14:15:27	s
29	Date and time of last 2 nd tariff index change	F231	Time/Date	2011-08-27 14:15:27	s
30	Date and time of last 3 rd tariff index change	F232	Time/Date	2011-08-27 14:15:27	s
31	Number of tariff index changes	F22F	Short	200	
32	Supply Group Code (SGC)	“901132”	constant		
33	Key revision number	“1”	constant		
34	Present Power Factor	E026	Float	123.45	
38	Energy measured since last format	1E00 (Assuming TOU ch1)	Float	78.59	kWh
39	Power consumption in current month	0000	Float	78.60	kWh
40	Power consumption of last month	0200	Float	0.00	kWh
41	Power consumption of 2nd month	0400	Float	0.00	kWh
42	Power consumption of 3rd month	0600	Float	0.00	kWh
43	Power consumption of 4th month	0800	Float	0.00	kWh
44	Power consumption of 5th month	0A00	Float	0.00	kWh
45	Power consumption of 6th month	0C00	Float	0.00	kWh
46	Power consumption of 7th month	0E00	Float	0.00	kWh
47	Power consumption of 8th month	1000	Float	0.00	kWh
48	Power consumption of 9th month	1200	Float	123.45	kWh
49	Power consumption of 10th month	1400	Float	123.45	kWh

50	Power consumption of 11th month	1600	Float	123.45	kWh
51	Power consumption of 12th month	1800	Float	123.45	kWh
55	Present Phase A average Power	E030	Float	0	W
56	Present PhB power	E031	Float	0	W
57	Present PhC Power	E032	Float	2577	W
58	Present PhA Current	E010	Float	0.00	A
59	Present PhB Current	E011	Float	0.00	A
60	Present PhC Current	E012	Float	11.38	A
61	Present PhA Voltage	E000	Float	0.00	V
62	Present PhB Voltage	E001	Float	0.00	V
63	Present PhC Voltage	E002	Float	226.32	V
70	Power purchase token of last time	F310	String	1892322345 2304456000	
71	Power purchase token of last 2nd time	F311	String	1892322345 2304456000	
72	Power purchase token of last 3rd time	F312	String	1892322345 2304456000	
73	Power purchase token of last 4th time	F313	String	1892322345 2304456000	
74	Power purchase token of last 5th time	F314	String	1892322345 2304456000	
75	Power purchase token of last 6th time	F315	String	1892322345 2304456000	
76	Power purchase token of last 7th time	F316	String	1892322345 2304456000	
77	Power purchase token of last 8th time	F317	String	1892322345 2304456000	
78	Power purchase token of last 9th time	F318	String	1892322345 2304456000	
79	Power purchase token of last 10th time	F319	String	1892322345 2304456000	
80	Time and date of last valid token loaded	F320	Time/Date	2011-08-27 14:15:27	s
81	Time and date of last 2 nd valid token loaded	F321	Time/Date	2011-08-27 14:15:27	s
82	Time and date of last 3 rd valid token loaded	F322	Time/Date	2011-08-27 14:15:27	s
83	Time and date of last 4 th valid token loaded	F323	Time/Date	2011-08-27 14:15:27	s
84	Time and date of last 5 th valid token loaded	F324	Time/Date	2011-08-27 14:15:27	s
85	Time and date of last 6 th valid token loaded	F325	Time/Date	2011-08-27 14:15:27	s

	loaded			14:15:27	
86	Time and date of last 7 th valid token loaded	F326	Time/Date	2011-08-27 14:15:27	s
87	Time and date of last 8 th valid token loaded	F327	Time/Date	2011-08-27 14:15:27	s
88	Time and date of last 9 th valid token loaded	F328	Time/Date	2011-08-27 14:15:27	s
89	Time and date of last 10 th valid token loaded	F329	Time/Date	2011-08-27 14:15:27	s
90	kwh values from the last credit token	F330	Long	4.50	kWh
91	kwh values from the last 2 nd credit token	F331	Long	3.70	kWh
92	kwh values from the last 3 rd credit token	F332	Long	5.20	kWh
93	kwh values from the last 4 th credit token	F333	Long	20.00	kWh
94	kwh values from the last 5 th credit token	F334	Long	10.00	kWh
95	kwh values from the last 6 th credit token	F335	Long	4.50	kWh
96	kwh values from the last 7 th credit token	F336	Long	3.70	kWh
97	kwh values from the last 8 th credit token	F337	Long	5.20	kWh
98	kwh values from the last 9 th credit token	F338	Long	20.00	kWh
99	kwh values from the last 10 th credit token	F339	Long	10.00	kWh
100	the last engineering token	F340	String	2979440793 8320483066	
101	the last 2 nd engineering token	F341	String	2979440793 8320483066	
102	the last 3 rd engineering token	F342	String	2979440793 8320483066	
103	the last 4 th engineering token	F343	String	2979440793 8320483066	
104	the last 5 th engineering token	F344	String	2979440793 8320483066	
105	the last 6 th engineering token	F345	String	2979440793 8320483066	
106	the last 7 th engineering token	F346	String	2979440793 8320483066	
107	the last 8 th engineering token	F347	String	2979440793	

				8320483066	
108	the last 9 th engineering token	F348	String	2979440793 8320483066	
109	the last 10 th engineering token	F349	String	2979440793 8320483066	
110	time/date of the last engineering token	F350	Time/Date	2011-08-27 14:15:27	
111	time/date of the last 2 nd engineering token	F351	Time/Date	2011-08-27 14:15:27	
112	time/date of the last 3 rd engineering token	F352	Time/Date	2011-08-27 14:15:27	
113	time/date of the last 4 th engineering token	F353	Time/Date	2011-08-27 14:15:27	
114	time/date of the last 5 th engineering token	F354	Time/Date	2011-08-27 14:15:27	
115	time/date of the last 6 th engineering token	F355	Time/Date	2011-08-27 14:15:27	
116	time/date of the last 7 th engineering token	F356	Time/Date	2011-08-27 14:15:27	
117	time/date of the last 8 th engineering token	F357	Time/Date	2011-08-27 14:15:27	
118	time/date of the last 9 th engineering token	F358	Time/Date	2011-08-27 14:15:27	
119	time/date of the last 10 th engineering token	F359	Time/Date	2011-08-27 14:15:27	

§ 15.19 Labelling requirements.

This device complies with part 15 of the FCC Rules. Operation is subject to the following two conditions: (1) This device may not cause harmful interference, and (2) this device must accept any interference received, including interference that may cause undesired operation.

§ 15.21 Information to user.

Any Changes or modifications not expressly approved by the party responsible for compliance could void the user's authority to operate the equipment.

§ 15.105 Information to the user.

This equipment has been tested and found to comply with the limits for a Class B digital device, pursuant to part 15 of the FCC Rules. These limits are designed to provide reasonable protection against harmful interference in a residential installation. This equipment generates uses and can radiate radio frequency energy and, if not installed and used in accordance with the instructions, may cause harmful interference to radio communications. However, there is no guarantee that interference will not occur in a particular installation. If this equipment does cause harmful interference to radio or television reception, which can be determined by turning the equipment off and on, the user is encouraged to try to correct the interference by one or more of the following measures:

- Reorient or relocate the receiving antenna.
- Increase the separation between the equipment and receiver.
- Connect the equipment into an outlet on a circuit different from that to which the receiver is connected.
- Consult the dealer or an experienced radio/TV technician for help.