

FOR AGES 10 AND UP

# INSTRUCTIONS / PRECAUTIONS

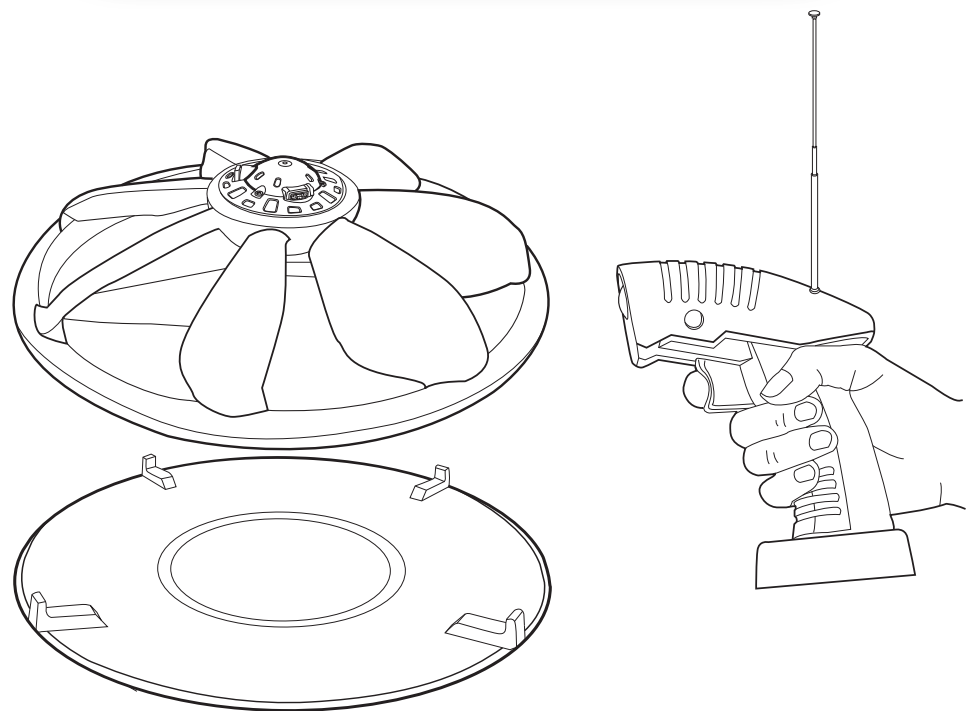

### Battery Safety

- Your Vectron Ultralite is only to be charged under adult supervision.
- Never expose the Vectron Ultralite battery pack to direct sun, hot areas, or fire as it may explode.
- The Ultralite charger and battery may become warm during charging.
- The Ultralite charging cord must be disconnected from the Vectron Ultralite when it is fully charged.
- Never leave your Vectron Ultralite connected to the AC adaptor overnight.
- Never overcharge the Vectron Ultralite as it can damage the rechargeable battery.

### Battery Care

- For maximum performance, always allow your battery of the Vectron Ultralite to drain before recharging.
- Never charge a second time without discharging first. This will affect or damage the battery.

### Battery Disposal

- Do not dispose of the battery in your regular household waste.
- Contact your local waste management officials for information on environmentally sound disposal of rechargeable batteries.
- If a battery leak develops, avoid contact with leaking fluid. Place the damaged battery in a plastic bag for proper disposal.
- If fluid comes in to contact with skin or eyes, wash with cool water for at least 15 mins.

### Battery Removal

- Remove the 3 screws on the top of the Vectron Ultralite with a Phillips screwdriver, disassemble the unit and remove the rechargeable battery.

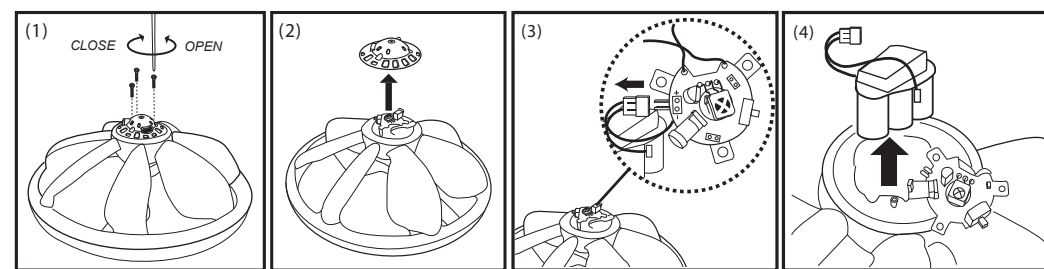

### TIPS:

- For your first flight, ensure there are no strong air currents from fans, air conditioners or open windows.
- Adjust the trigger to find the correct position so your Vectron Ultralite will hover preventing it from flying too high or too low. It will take some practice to get the hang of it.
- Always point the thrust transmitter towards your Vectron Ultralite to ensure a steady controllable flight.
- Do not try to land your Vectron Ultralite on to the launch platform. Try to land on any open floor area.
- Your Vectron Ultralite can also take off from any smooth flat surface. Do not try to take off from deep pile carpet or soft furniture. This may jam the propeller before take off.

### Learning More About Your Vectron Ultralite

#### Technical Specifications

Recommended Age		10 and UP
Vectron Ultralite	Flying Range	50 ft. (15 m)
	Rechargeable Battery Type	6 V 100mA Ni-MH
	Working Voltage	5 V
	Working Current	8 W (Peak)
Ultralite Controller	Batteries	9V (6LR61) alkaline batteries
	Power Consumption	0.3 W (Peak)
	Working Voltage (DC)	6.5 V ~ 9 V
Ultralite Charging Devices	Charge Duration	10 minutes (max.)
	Charge Method	-ΔV detect plus master timeout
	i) AC Adaptor Output AC Adaptor Input	DC 13V 0.6A 120V AC 60Hz 10W

### WARNING!

- CAUTION: Electrically operated product. Not recommended for children under 10 years of age. As with all electric products, precautions should be observed during handling and use to prevent electric shock.
- Keep face, eyes, fingers, hair, body parts etc. away from the propeller and other moving parts.
- Always fly the Vectron Ultralite in an open space.
- Do not expose your Vectron Ultralite to rain or moisture.
- Do not fly in a crowded environment.
- Do not fly in a dusty area.
- Do not fly in complete darkness.
- Ensure people know that you are flying the Vectron Ultralite.
- Use only your Ultralite controller included in this package.
- Always turn your Vectron Ultralite "OFF" when not in use.

### General

- Your Vectron Ultralite must not be used if there is any damage to the AC adaptor, charging cord, charging socket, rechargeable battery, propeller, ring or other parts of the Vectron Ultralite.
- Do not attempt to lift objects with your Vectron Ultralite.
- Vectron Ultralite is a high tech precision instrument and is vulnerable to misuse. Protecting all components is an essential part of flight maintenance.

### AC Adaptor Important Information

- This toy is not intended for children under 3 years old.
- The instruction manual contains important information and must be kept.
- This toy only operates with supplied AC adaptor.
- The use of the AC adaptor should be supervised by an adult and examined regularly.
- This toy must not be used if there is any damage to the power cord, plug and other parts of the transformer.
- The AC adaptor must be disconnected before cleaning.

### I) Thrust Transmitter

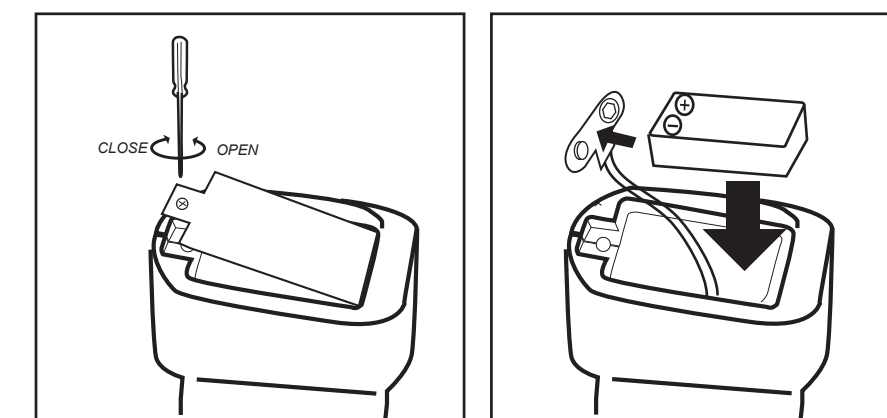
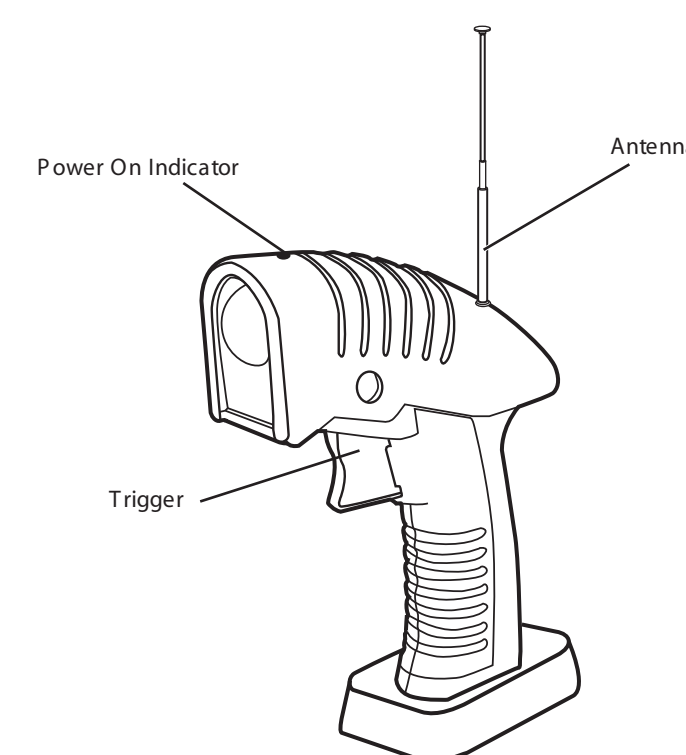

- 1) Open or close the cover with a Phillips screwdriver.
- 2) Insert one size "9V" (6LR61) Alkaline batteries.

### II) Flight Preparation

#### IMPORTANT:

- 1) Ensure the AC Adaptor voltage and plug is suitable for your area.
- 2) Connect the AC Adaptor to the wall outlet.

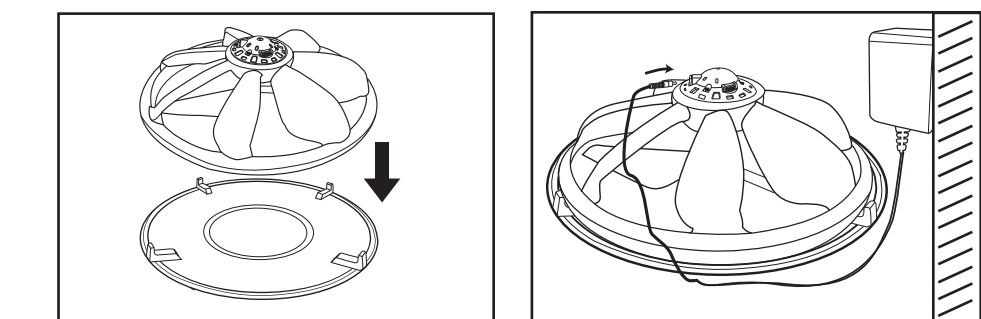

- 1) Place your Vectron Ultralite on to the launch platform.
- 2) Ensure your Vectron Ultralite is switched OFF, then connect the charging cord to your Vectron Ultralite.

#### NOTES:

- The red and green LED will blink alternately. It will take approximately 10 minutes to charge your Vectron Ultralite completely; at this point the green LED will flash continuously.
- When your Vectron Ultralite is new or has not been flown for a long time it will take several charge/discharge cycles for the battery to reach its full flight time.

**WARNING:** Never recharge your Vectron Ultralite a second time without having flown first. Continuous recharging without discharging first, will damage the Ultralite battery.

**CAUTION:** Always recharge your Vectron Ultralite with supplied AC Adaptor! Operate with third-party AC Adaptor may cause damage to this product.

### Troubleshooting

Problem	Possible Cause	Solution
No power to the propeller	Your AC Adaptor is the wrong type or damaged preventing it from charging your Vectron Ultralite.	Contact your support team at <a href="mailto:service@bluetechnic.com">service@bluetechnic.com</a> stating the voltage and plug type required. Do not return your Vectron Ultralite to the retail store.
	Power switch is not turned on.	Slide the power switch to the ON position.
	Your Ultralite battery is not charged.	Charge your battery fully before flying.
The propeller auto-stop feature is activated. This feature is activated when the propeller is obstructed by body parts or objects. If your Vectron Ultralite crashes on to the floor, this may trigger the auto-stop feature as well. The red and green LED will blink alternately.		Reset your Vectron Ultralite by switching it off and turning it back on again to resume flight.
	The battery power is low.	Recharge the battery fully.
	Your Vectron Ultralite is not placed properly onto the launch platform.	Place your Vectron Ultralite properly sitting in the middle of the launch platform.
Your Vectron Ultralite does not take off.	Your Vectron Ultralite is out of range. The green LED does not come on which means there is no signal transmission.	Move closer to your Vectron Ultralite.
	The trigger is not depressed far enough on the thrust transmitter.	Depress the trigger at least half way.
	The room may have drafts from windows, fans, air conditioner and ventilation systems.	Minimize the drafts before take off.
	Operator error.	Wait for the red LED to flash before trying to take off.
Your Vectron Ultralite does not respond to the thrust transmitter.	The thrust transmitter battery is low. The red LED does not flash after depressing the trigger.	Replace the 9V (6LR61) Alkaline battery with new one.
	The thrust transmitter battery is inserted improperly.	Check and reinsert the battery with the proper polarity as per the markings in the holder.
	Your Vectron Ultralite is out of range. You are outdoors or flying in a large room with high ceiling.	Move closer to your Vectron Ultralite. Fly indoors with the appropriate ceiling height.

NOTE: The transparent labels underneath the ring are for protection against the propeller. A damaged ring can be repaired with transparent tape. Some glues may damage the polyfoam ring.

### Battery Safety Guidelines

- To prevent battery leakage: Be sure to insert batteries correctly.
- Batteries should be replaced by adult.
- Never dispose of batteries in fire as this may cause them to explode.
- Do not mix old and new batteries (replace all batteries at the same time).
- Do not mix Alkaline, standard (Carbon-Zinc) or rechargeable (Nickel-Cadmium) batteries (or equivalent). Only batteries of the same or equivalent type as recommended are to be used.
- Non-rechargeable batteries are not to be recharged.
- Always remove exhausted or dead batteries from product. Remove batteries from product which is not going to be used for a long time. Otherwise the batteries may leak and cause damage.
- The supply terminals are not to be short-circuited.
- Make sure battery compartment is secure.
- Do not immerse battery operated toys. Wipe clean only.

### Attention to maximize the life of your Vectron Ultralite

- Avoid continuously running at full power against a low ceiling, as this will shorten the saucers motor life.
- Instead hover and swoop below ceiling height or fly outdoors if wind condition permits.
- This will insure many hour of flying fun with your Vectron ultralite.

### III) Flying, Hovering and Landing Your Vectron Ultralite

**IMPORTANT:** Ensure your Vectron Ultralite is fully charged for first time use and that you have a least 10 ft. (3 m) of clear area.

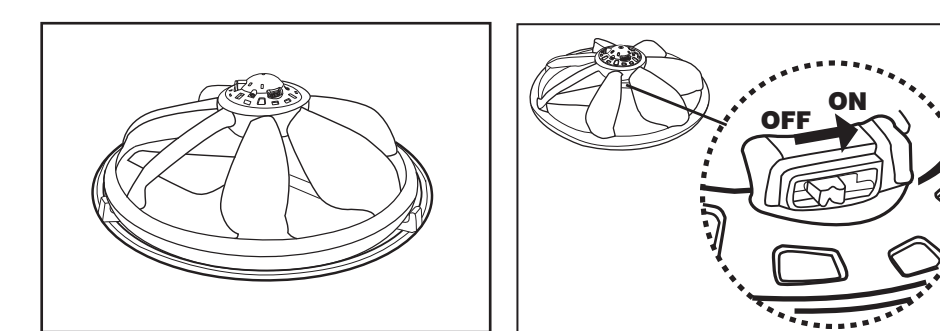

- 1) With your Vectron Ultralite on the launch platform, unplug the charging cord.
- 2) Switch on your Vectron Ultralite.

**NOTE:** After the red and green LED blink alternately, the red LED will start to flash slowly. At this time your Vectron Ultralite is ready for take off.

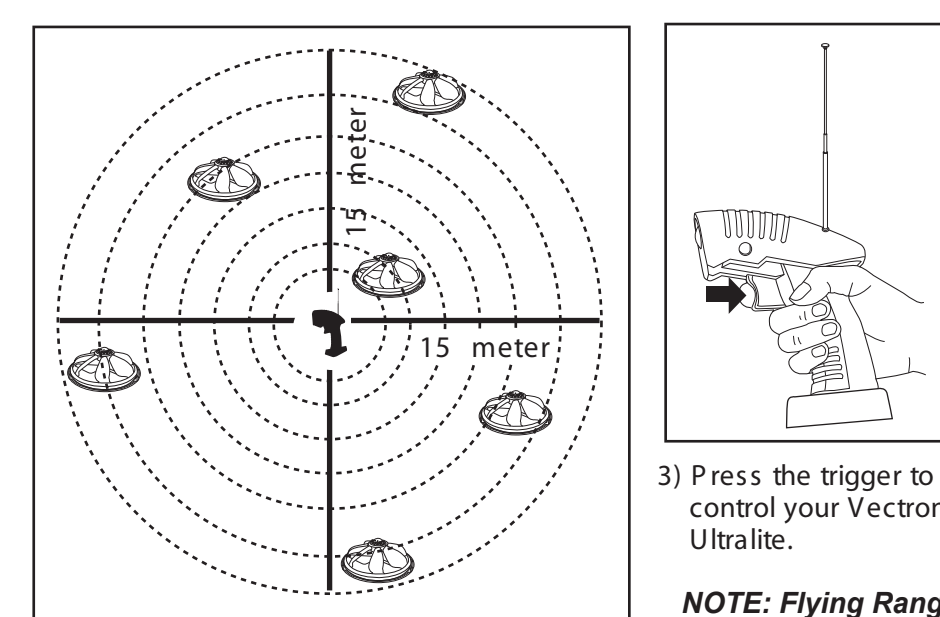

**NOTE:** Flying Range is around 50 ft.(15 m)

### Contents

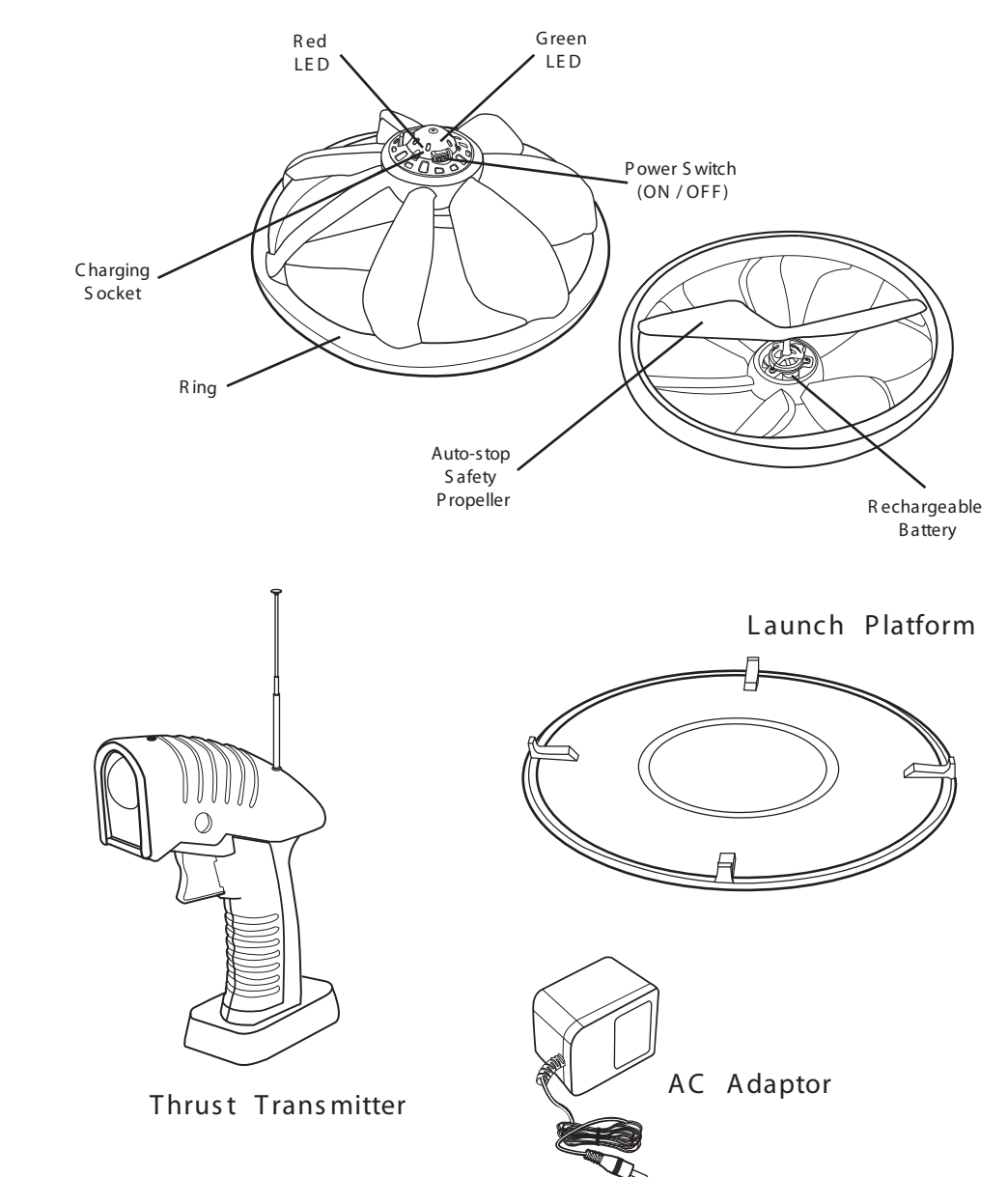

Thrust Transmitter

AC Adaptor

**NOTE:**

**THE MANUFACTURER IS NOT RESPONSIBLE FOR ANY RADIO OR TV INTERFERENCE CAUSED BY UNAUTHORIZED MODIFICATIONS TO THIS EQUIPMENT. SUCH MODIFICATIONS COULD VOID THE USER AUTHORITY TO OPERATE THE EQUIPMENT.**