

Android Tablet

Model:WA1012T

10.1" , 13.3" ,15.6"

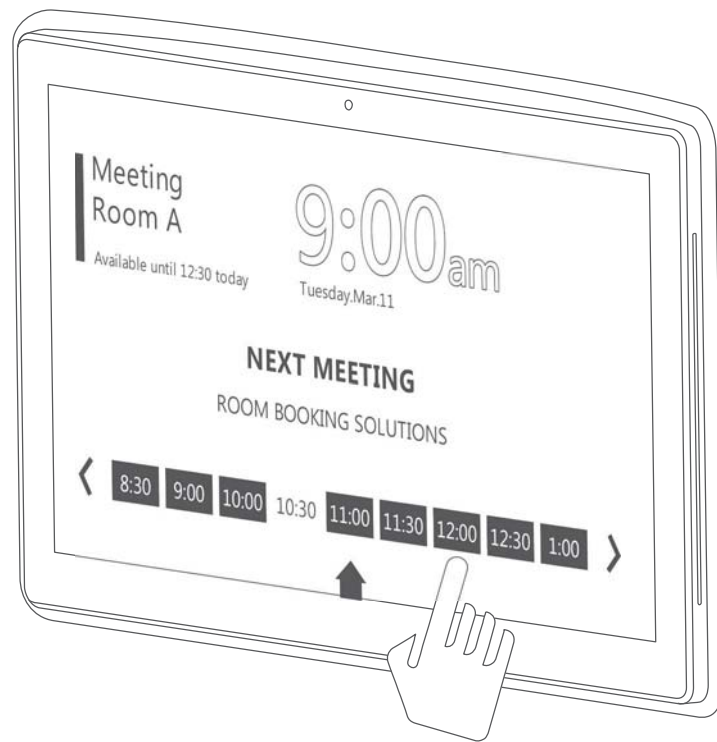

User Manual

Contents

| | |
|---|---|
| Important Notices..... | 2 |
| Package Contents..... | 3 |
| Introducing the meeting room interactive digital signage 10.1" , 13.3" , 15.6"..... | 4 |
| 10.1" Exterior Components..... | 5 |
| 13.3" Exterior Components..... | 6 |
| 15.6" Exterior Components..... | 7 |
| Installation instructions..... | 8 |

Important Notices

Copyright Information

All intellectual property rights in this publication are owned by and protected by applicable copyright laws and international treaty provisions. retains all rights not expressly granted. No part of this publication may be reproduced in any form whatsoever or used to make any derivative work without prior written approval by . Reserves the right to revise this publication, and/or make improvements or changes in the product(s) and/or the program(s) described in this documentation at any time without prior notice. The information in this document is provided in good faith, but without any representation or warranty whatsoever, whether it is accurate, or complete or otherwise, and on express understanding that shall have no liability whatsoever to other parties in any way arising from or relating to the information or its use.

All other trademarks are the property of their respective owners. Other company and brand products and service names are trademarks or registered trademarks of their respective holders.

This device complies with CE and FCC regulations.

1) Do not push objects into holes and ventilation slots.

Do not expose this product to moisture or place any objects filled with liquids on or near the product.

Do not place a naked flame source, such as lighted candles, on or near this product.

Do not store or operate the device in environments where the temperature is above 50 degrees celsius or below -10 degrees celsius.

Do not intentionally hit the device or place heavy or sharp objects on the device.

Only use accessories specified by the manufacturer.

Keep the device away from benzene, diluents, and other chemicals.

Do not attempt to repair this product yourself. Always use a qualified service agent to perform adjustments or repairs.



Package Contents

Please make sure all of the following are present when you unpack your meeting room interactive digital signage.

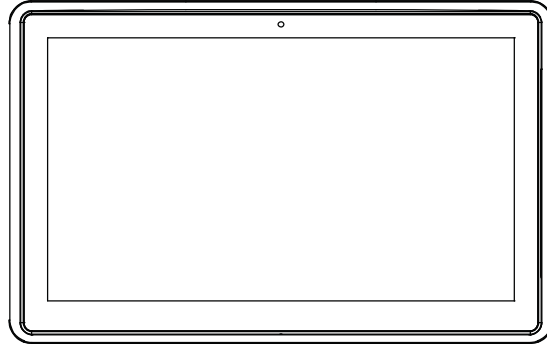

Meeting room interactive digital signage

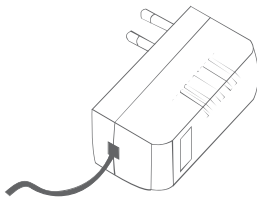

Power adapter

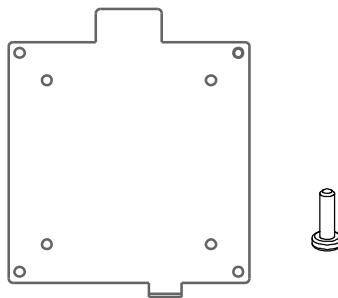

Bracket/ Screw



User manual

Introducing the Meeting room interactive digital signage 10.1" , 13.3" , 15.6"

- RK3288,Quad-core cortex A17,1.8G
- Resolution:800*1280 ,10.1" / Resolution:1920*1080 13.3" , 15.6" LCD IPS panel
- Android 5.1+
- 10-Point capacitive touch
- RAM 2GB/Internal memory 8GB
- 2.0M/P/Front camera /Microphone
- Ethernet with PoE
- Wi-Fi 802.11b/g/n
- Bluetooth 4.0
- 2*2W Speaker
- USB Host*1/Micro USB OTG/SD Card
- Serial port (USB)
- VESA 75*75mm

*If required, please ask for detailed specifications.

10.1" Exterior Components

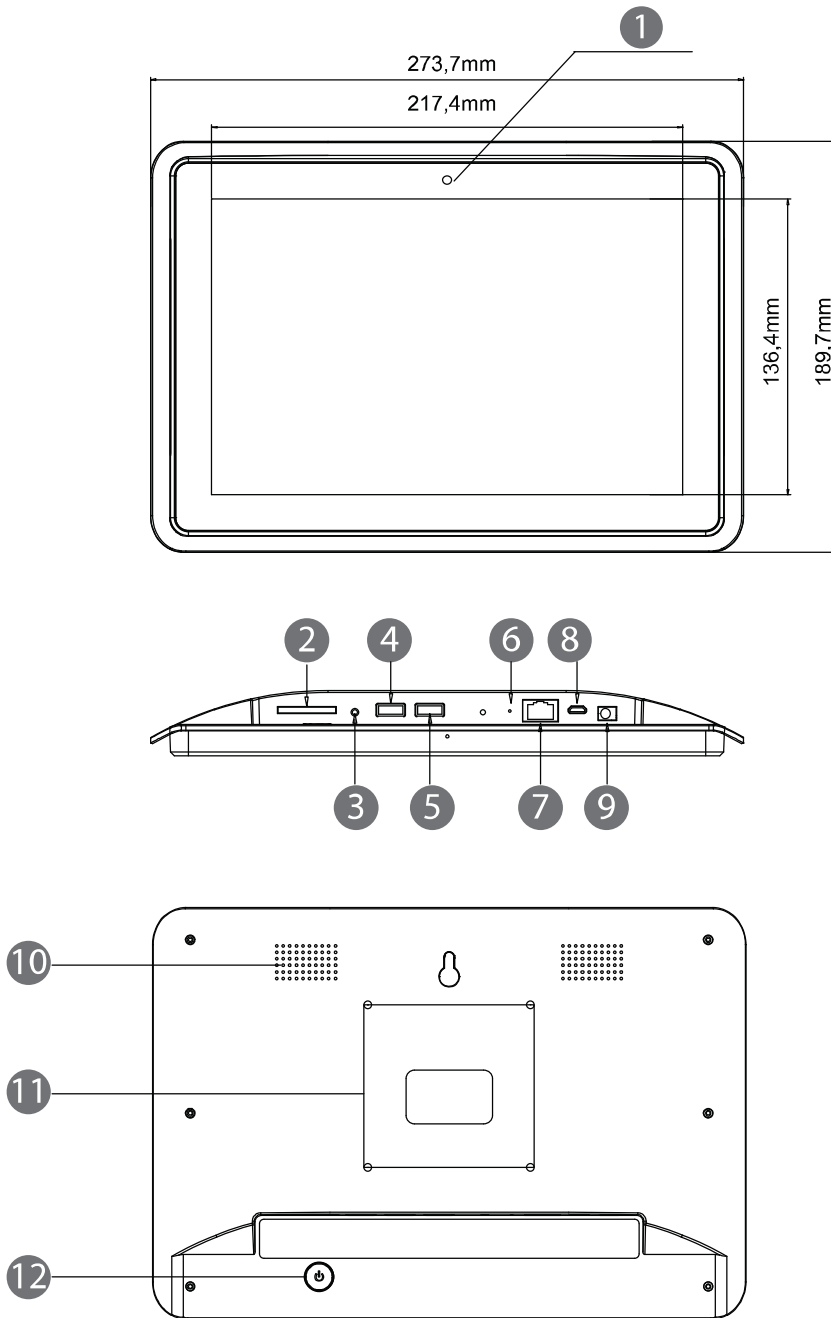

| No | Function | No | Function |
|----|------------------|----|-------------------------|
| 1 | Camera | 7 | Ethernet with PoE |
| 2 | SD Card slot | 8 | Micro USB OTG |
| 3 | 3.5mm audio jack | 9 | DC in power supply port |
| 4 | USB 2.0 host | 10 | Speaker |
| 5 | Serial port | 11 | VESA 75*75MM |
| 6 | Recovery key | 12 | Power button |

13.3" Exterior Components

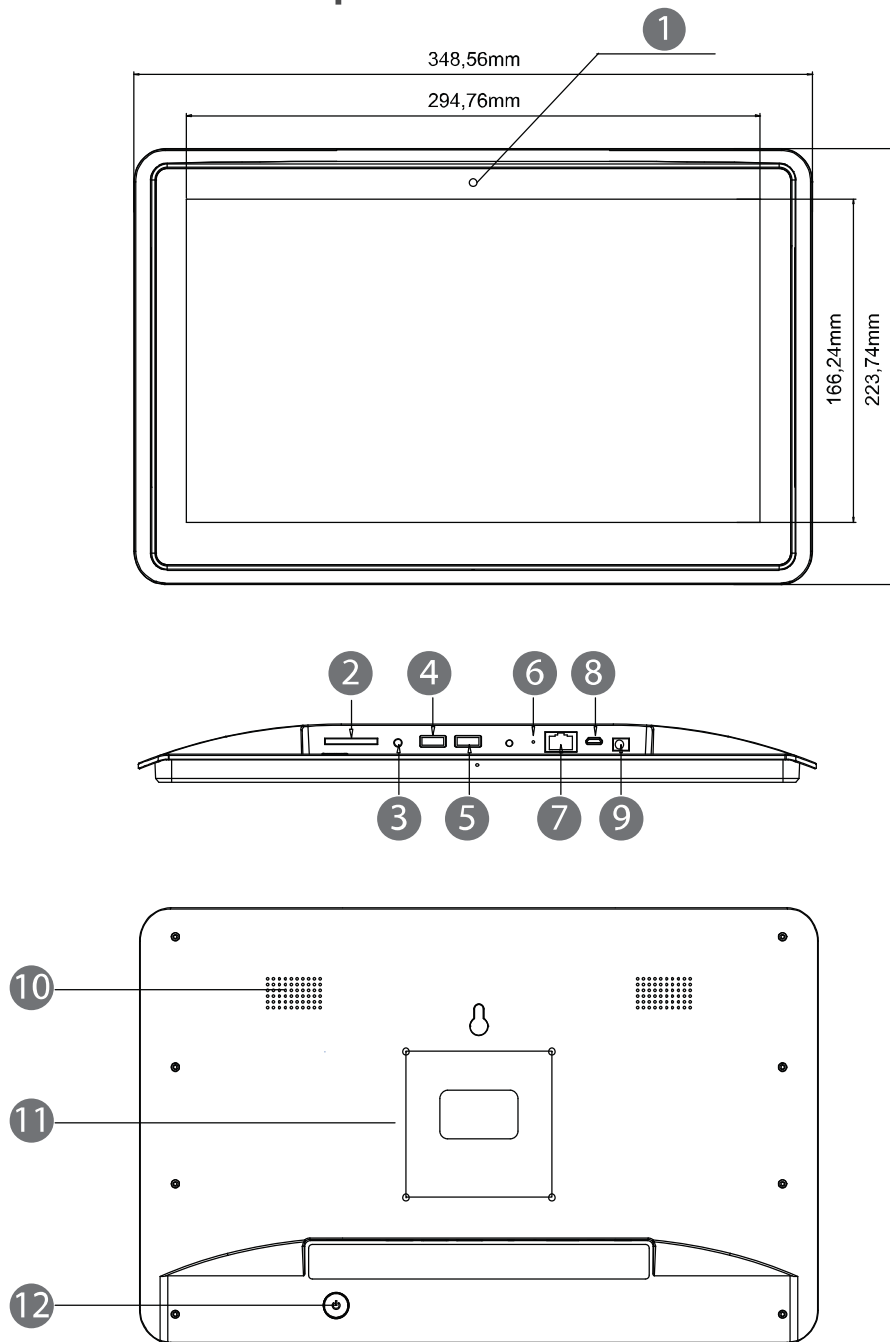

| No | Function | No | Function |
|----|------------------|----|-------------------------|
| 1 | Camera | 7 | Ethernet with PoE |
| 2 | SD Card slot | 8 | Micro USB OTG |
| 3 | 3.5mm audio jack | 9 | DC in power supply port |
| 4 | USB 2.0 host | 10 | Speaker |
| 5 | Serial port | 11 | VESA 75*75MM |
| 6 | Recovery key | 12 | Power button |

15.6" Exterior Components

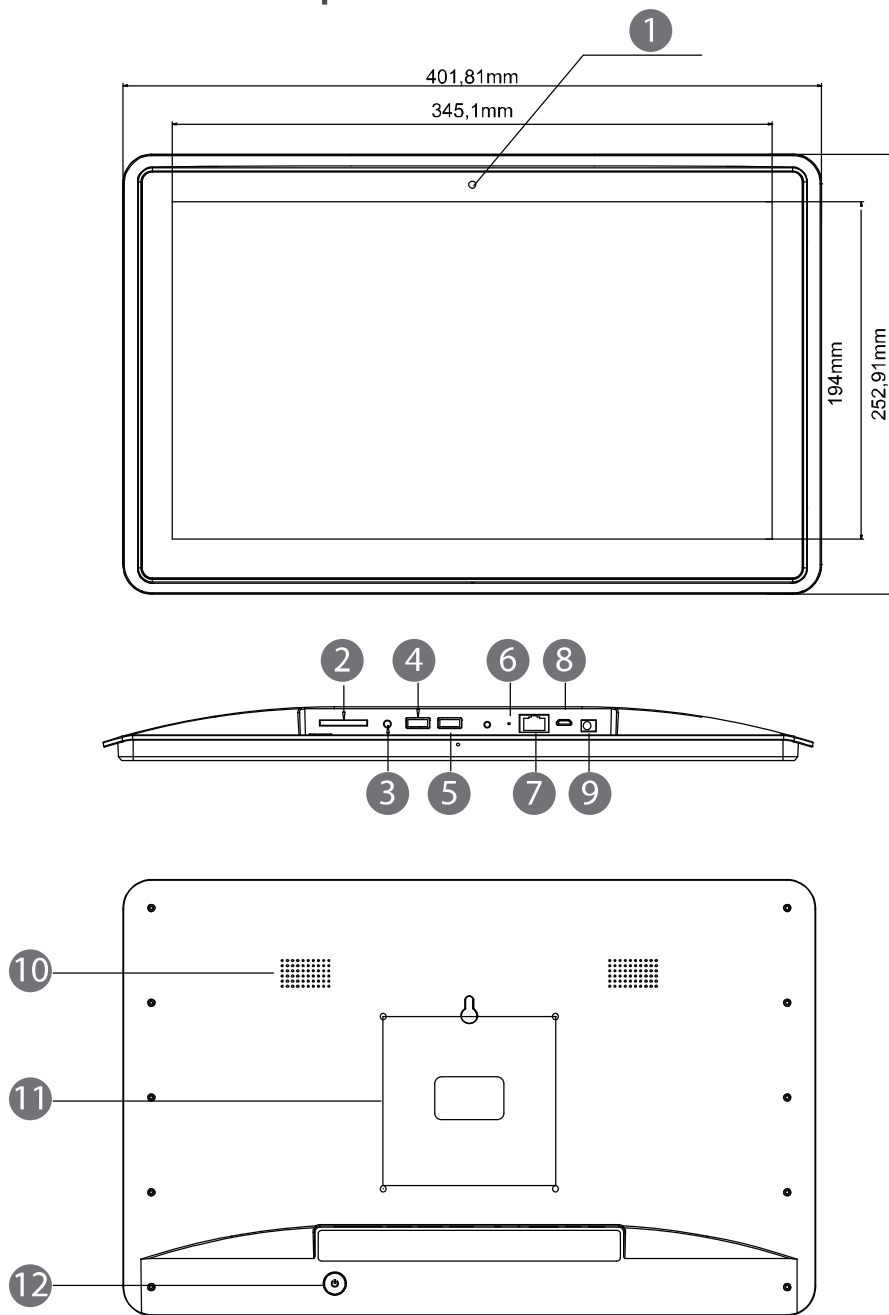

| No | Function | No | Function |
|----|------------------|----|-------------------------|
| 1 | Camera | 7 | Ethernet with PoE |
| 2 | SD Card slot | 8 | Micro USB OTG |
| 3 | 3.5mm audio jack | 9 | DC in power supply port |
| 4 | USB 2.0 host | 10 | Speaker |
| 5 | Serial port | 11 | VESA 75*75MM |
| 6 | Recovery key | 12 | Power button |

Installation instructions

1

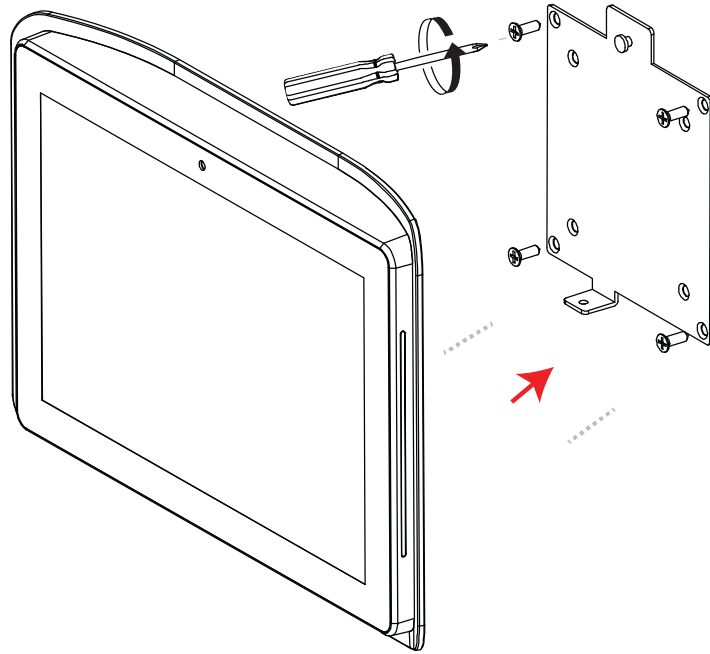

2

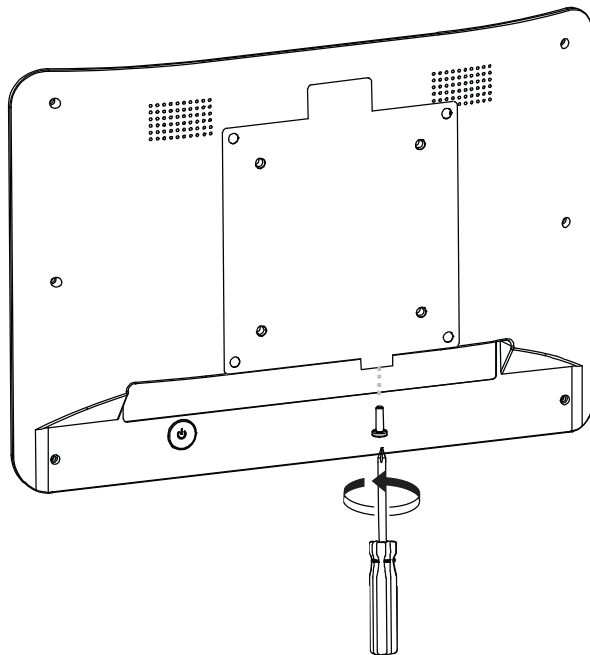



This symbol on the product or in the instructions means that your electrical and electronic equipment should be disposed of at the end of its life separately from your household waste. There are separate collection systems for recycling in your country. For more information, please contact the local authority or your retailer where you purchased the product.

FCC Statement

This equipment has been tested and found to comply with the limits for a Class B digital device, pursuant to part 15 of the FCC rules. These limits are designed to provide reasonable protection against harmful interference in a residential installation. This equipment generates, uses and can radiate radio frequency energy and, if not installed and used in accordance with the instructions, may cause harmful interference to radio communications. However, there is no guarantee that interference will not occur in a particular installation. If this equipment does cause harmful interference to radio or television reception, which can be determined by turning the equipment off and on, the user is encouraged to try to correct the interference by one or more of the following measures:

- Reorient or relocate the receiving antenna.
- Increase the separation between the equipment and receiver.
- Connect the equipment into an outlet on a circuit different from that to which the receiver is connected.
- Consult the dealer or an experienced radio/TV technician for help.

To assure continued compliance, any changes or modifications not expressly approved by the party.

Responsible for compliance could void the user's authority to operate this equipment. (Example- use only shielded interface cables when connecting to computer or peripheral devices).

This equipment complies with Part 15 of the FCC Rules. Operation is subject to the following two conditions:

- (1) This device may not cause harmful interference, and
- (2) This device must accept any interference received, including interference that may cause undesired operation.

FCC Radiation Exposure Statement:

The equipment complies with FCC Radiation exposure limits set forth for uncontrolled environment. This equipment should be installed and operated with minimum distance 20cm between the radiator and your body.