

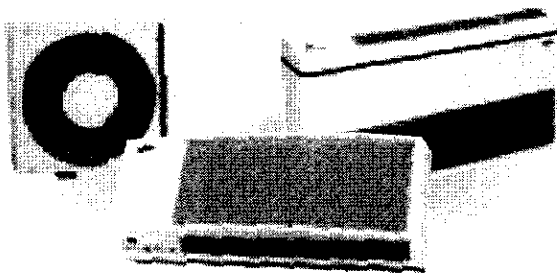

[DUCTLESS SPLIT SYSTEMS]



EMC *AmericaSeries*
Comfort Where It Counts.

Convenient, Efficient, Easy To Operate

Made in the USA

Whether you're adding rooms or modifying an existing residential or commercial structure, EMI AmericaSeries Ductless Split Systems make it easy to enjoy conditioned comfort minus the ductwork.

Efficiently designed AmericaSeries Ductless Split Systems allow you to cut your energy costs by cooling or heating zones as required. Unlike central air, each zone is controlled independently allowing you to use energy wisely – only where and when you need it. Easily operated AmericaSeries systems feature your choice of unit mount digital controls, hand-held infra-red remote controls or 24-volt wall mount thermostats.

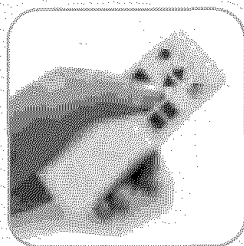

The EMI AmericaSeries Advantage

EMI's AmericaSeries line of ductless split air conditioning is the most comprehensive, flexible and unique ductless line in the industry. Select from over 100 single or multi-zone systems for cooling only or heat pump applications. With exceptional performance, operating efficiency, and EMI exclusive features – the EMI AmericaSeries is the number one choice for "Comfort Where It Counts."

EMI AmericaSeries Systems Feature:

- Optional electric heat on both straight cool and heat pump air handlers.
- Low ambient cooling down to 60°F Standard (outside temperature), with optional low ambient cooling available down to 0°F (outside temperature).
- The flexibility of a full line of air handlers...
Floor - FHP, Corner - CNR, Wall - WHP, Ceiling - CHP,
T-Bar - TBH, and Cassette - CAH.
- Cassette capabilities starting at 9,000 BTU/h.
- Low voltage interconnect between air handler and condenser.
- 100 ft. of total interconnect (maximum of 35 ft. vertical lift).
- Optional integrated condensate pump (factory or field installed).
- Optional wall thermostat operation
(with 24-volt manual or programmable thermostat).
- Schrader ports for ease of serviceability.
- Multi-zone condensers capable of handling
four different types of air handlers.
- Availability of DX, Chilled Water or Hot Water
operation on most air handlers.

Mix & Match

100+ Single or Multi-Zone System Combinations to choose from...

Single Zone Systems

Single air handler and condenser provide cooling or heating to one zone. Choose from a multitude of combinations of air handler styles and capacities to fit your specific comfort needs.

25+
zone
Combinations

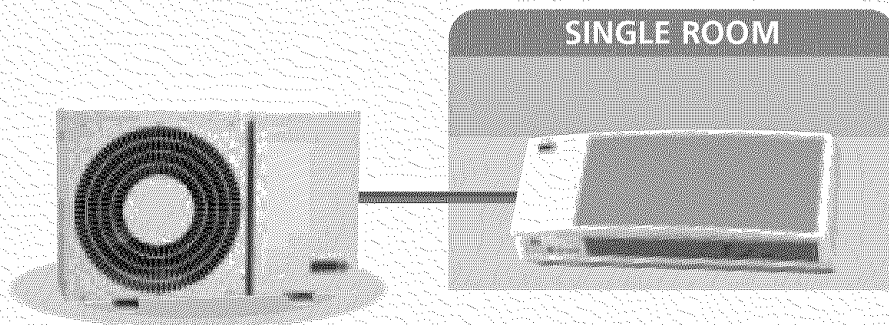

Multi-Zone Systems

Single condenser operates up to four independent zones, with each zone having separate refrigerant and electrical lines. Air handler styles and capacities can be tailored to the individual requirements of each zone.

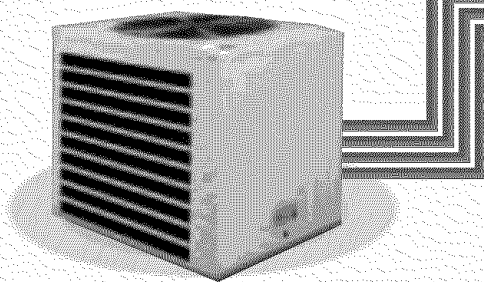

EMI AmericaSeries multi-zone systems are available in over 75 circuit combinations.

75+
zone
Combinations

Only EMI AmericaSeries allows you to mix air handler styles as well as capacities within one multi-zone system.

WHP Series Wall Air Handlers

MODEL	COOLING Nom. BTU/H	OPTIONAL HEATING	DIMENSIONS		
			L	H	D
WHP 09	9,000	3 KW	36 1/2	14 1/2	10 3/4
WHP 12	12,000	3 KW	36 1/2	14 1/2	10 3/4
WHP 15	15,000	3 KW	47 1/2	14 1/2	10 3/4
WHP 18	18,000	3 KW	47 1/2	14 1/2	10 3/4
WHP 24	24,000	5 KW	57 1/2	14 1/2	10 3/4
WHP 30	30,000	5 KW	57 1/2	14 1/2	10 3/4
WHP 36	36,000	5 KW	57 1/2	17	11 1/4

The high wall unit is also available as a 2-pipe Chilled Water Fan Coil. Use only 24 volt control and valves for chilled water applications and refer to the WCP specifications for complete details.

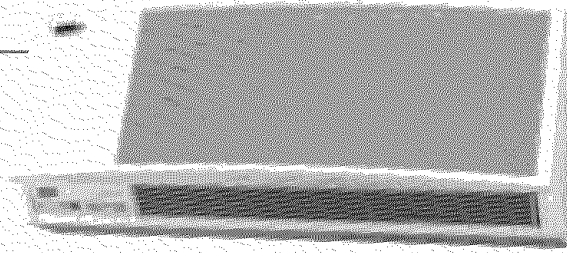

Model WHP 09-12

FEATURES:

- Standard cooling down to 60°F (outside temperature).
- Unit Mounted Digital Control with large 3/4" lighted LCD display
- Anti short cycle protection
- Hi/Low Fan Speeds with auto ramp operation
- Fan Post Purge
- Auto re-start memory
- De-humidification feature
- 208/230 standard voltage

OPTIONS:

- Expanded low ambient cooling operation down to 0°F (outside temperature) with EMI Low Ambient Kit used with an AmericaSeries Air Handler & Condenser.
- Field or factory installed Internal Condensate Pump
- Full Function, hand held infra-red controller
- 24Volt remote thermostat control and thermostat
- Electric heat (see chart)

CHP Series Ceiling Mounted Units

MODEL	COOLING Nom. BTU/H	OPTIONAL HEATING	DIMENSIONS		
			L	H	D
CHP 09	9,000	3 KW	42	10 3/4	24
CHP 12	12,000	3 KW	42	10 3/4	24
CHP 15	15,000	3 KW	42	10 3/4	24
CHP 18	18,000	5 KW	49	10 3/4	24
CHP 24	24,000	5 KW	49	10 3/4	24
CHP 30	30,000	5 KW	49	10 3/4	24
CHP 36	36,000	7 KW	59	12 3/4	24
CHP 42	42,000	7 KW	59	12 3/4	24
CHP 48	48,000	7 KW	59	12 3/4	24

The high wall unit is also available as a 2-pipe Chilled Water Fan Coil. Use only 24 volt control and valves for chilled water applications and refer to the CCP specifications for complete details.

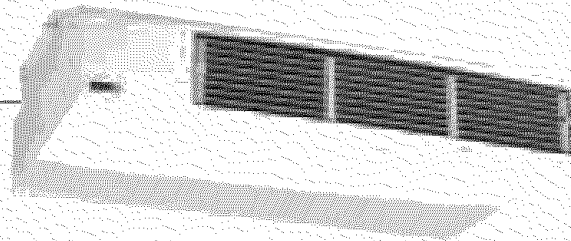

Model CHP 09-15

FEATURES:

- Standard cooling down to 60°F (outside temperature).
- 24 Volt wall thermostat control
- Fresh air knockout
- Anti short cycle protection
- 208/230 standard voltage

OPTIONS:

- Expanded low ambient cooling operation down to 0°F (outside temperature) with EMI Low Ambient Kit used with an AmericaSeries Air Handler & Condenser.
- Unit mounted infra-red digital control and hand held remote controller
- Hydronic heat
- Field or factory installed Condensate pump
- Trim kit for surface mounted units
- Electric heat (see chart)

CAH Series Ceiling Cassettes

MODEL	COOLING Nom. BTU/H	OPTIONAL HEATING	DIMENSIONS		
			L	H	D
CAH 09	9,000	1.5 KW	22 1/2	9 1/4	22 1/2
CAH 12	12,000	1.5 KW	22 1/2	9 1/4	22 1/2
CAH 15	15,000	3 KW	32 1/4	9 1/2	32 1/4
CAH 18	18,000	3 KW	32 1/4	9 1/2	32 1/4
CAH 24	24,000	3 KW	32 1/4	9 1/2	32 1/4
CAH 30	30,000	5 KW	44 1/2	11 1/2	32 1/2
CAH 36	36,000	5 KW	44 1/2	11 1/2	32 1/2
CAH 42	42,000	5 KW	44 1/2	11 1/2	32 1/2
CAH 48	48,000	5 KW	44 1/2	11 1/2	32 1/2

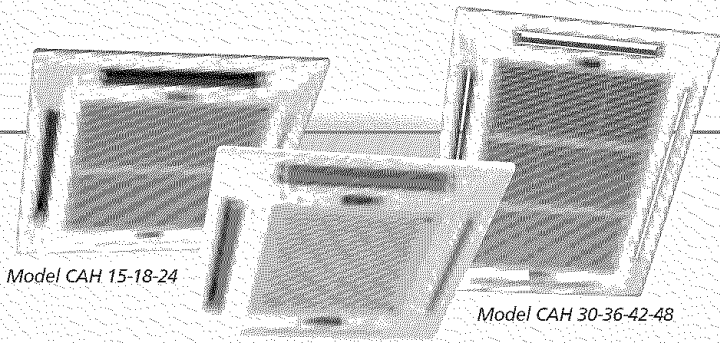

Model CAH 15-18-24

Model CAH 30-36-42-48

Model CAH 09-12

FEATURES:

- Standard cooling down to 60°F (outside temperature).
- 4 way motorized discharge vanes (18-48 models on CAH)
- 18" head condensate pump with safety float switch
- Fresh Air knockouts
- Branch duct knockouts
- Controls accept 24V thermostat
- Anti short Cycle Protection
- 208/230 standard voltage
- Electric heat (see chart)

OPTIONS:

- Expanded low ambient cooling operation down to 0°F (outside temperature) with EMI Low Ambient Kit used with an AmericaSeries Air Handler & Condenser.
- Infra-red hand held digital controller
- CAHW models may be equipped with hydronic heat

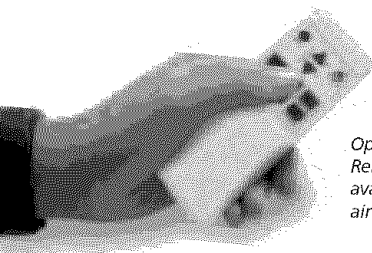

Optional Infra-red Remote Controller available for all air handlers.

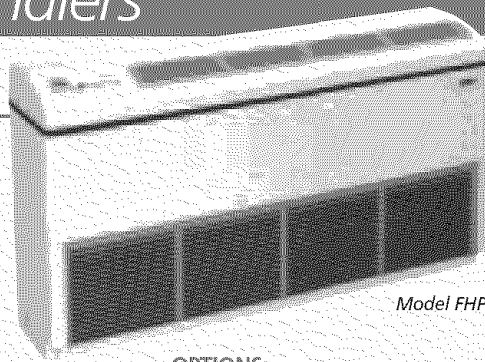

Model FHP

FEATURES:

- Standard cooling down to 60°F (outside temperature).
- Unit Mounted Digital Control
- Anti Short Cycle Protection
- Fresh Air Knockout
- 208/230 standard voltage

OPTIONS:

- Expanded low ambient cooling operation down to 0°F (outside temperature) with EMI Low Ambient Kit used with an AmericaSeries Air Handler & Condenser.
- Powered Fresh Air Motorized Damper and Fan Induced air intake
- Hot water supplemental heat (cooling only applications)
- Full Function, hand held infra-red controller
- 24Volt remote thermostat control and thermostat
- Condensate pump (115volt or 208/230 volt-factory installed)
- 115 Volt (09, 12 models only)
- Electric heat (see chart)

FHP Series Floor Console

MODEL	COOLING Nom. BTU/H	OPTIONAL HEATING	DIMENSIONS		
			L	H	D
FHP 09	9,000	3 KW	47	26	10 1/2
FHP 12	12,000	3 KW	47	26	10 1/2
FHP 15	15,000	3 KW	47	26	10 1/2
FHP 18	18,000	5 KW	47	26	10 1/2
FHP 24	24,000	5 KW	47	26	10 1/2
FHP 30	30,000	5 KW	47	26	10 1/2
FHP 36	36,000	7 KW	61 1/2	26	10 1/2
FHP 42	42,000	7 KW	61 1/2	26	10 1/2
FHP 48	48,000	7 KW	61 1/2	26	10 1/2

The floor console is also available as a 2-pipe Chilled Water Fan Coil. Refer to specifications for the FCP. 24 volt control only. Use only 24 volt valves.

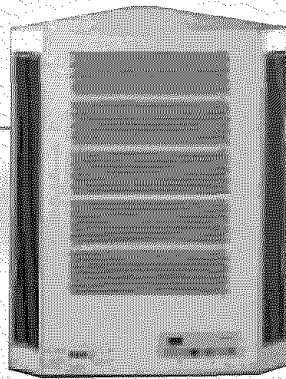

Model CNR

FEATURES:

- Standard cooling down to 60°F (outside temperature).
- Attractive compact design
- Ideal for small to mid-size commercial or residential spaces
- Easy to install, operate and service
- Whisper quiet operation
- Line sets may exit through either side or top of unit
- 208/230 standard voltage

OPTIONS:

- Expanded low ambient cooling operation down to 0°F (outside temperature) with EMI Low Ambient Kit used with an AmericaSeries Air Handler & Condenser.
- Top Trim Kit conceals any line sets or wiring, for finished look between unit and ceiling
- Integral Condensate Pump (Factory or Field installed)
- Optional controls: hand-held infra-red or 24 volt wall thermostat
- Electric heat (see chart)

CNR Series Corner Mount Unit

MODEL	COOLING Nom. BTU/H	OPTIONAL HEATING	DIMENSIONS		
			L	H	D
CNR 09	9,000	3 KW	25 1/2	31	13 5/8
CNR 12	12,000	3 KW	25 1/2	31	13 5/8

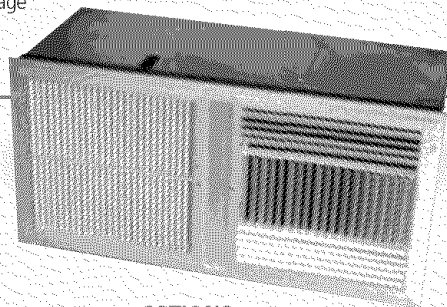

Model TBH

FEATURES:

- Standard cooling down to 60°F (outside temperature).
- 2 x 4 T-Bar design
- Ideal for small to mid-size commercial spaces
- Easy to install, operate and service
- Whisper quiet operation
- Fresh air knockouts
- 208/230 standard voltage
- Controls accept 24V thermostat

OPTIONS:

- Expanded low ambient cooling operation down to 0°F (outside temperature) with EMI Low Ambient Kit used with an AmericaSeries Air Handler & Condenser.
- Integral Condensate Pump (Factory or Field installed)
- Infra-red hand-held digital controller
- Electric heat (see chart)

TBH Series Lay-in Ceiling Units

MODEL	COOLING Nom. BTU/H	OPTIONAL HEATING	DIMENSIONS		
			L	H	D
TBH 09	9,000	3 KW	46 5/8	18 15/16	22 5/8
TBH 12	12,000	3 KW	46 5/8	18 15/16	22 5/8
TBH 18	18,000	5 KW	46 5/8	18 15/16	22 5/8
TBH 24	24,000	5 KW	46 5/8	18 15/16	22 5/8

SCC/SHC & C10

Single Zone Condensing Units

MODEL	COOLING Nom. BTU/H	HEAT PUMP CAPACITY	DIMENSIONS		
			L	H	D
SCC/SHC 09	9,500	9,000	34 1/8	24 1/4	12
SCC/SHC 12	12,000	11,200	34 1/8	24 1/4	12
SCC/SHC 15	15,800	14,100	34 1/8	24 1/4	12
SCC/SHC 18	18,000	17,500	44	26 1/4	14
SCC/SHC 24	23,600	21,500	44	26 1/4	14
SCC/SHC 30	28,500	28,500	44	26 1/4	14
SCC/SHC 36	33,000	31,000	44	26 1/4	14
C10 42	39,000	N/A	21 1/2	32 1/2	21 1/2
C10 48	43,000	N/A	21 1/2	32 1/2	21 1/2

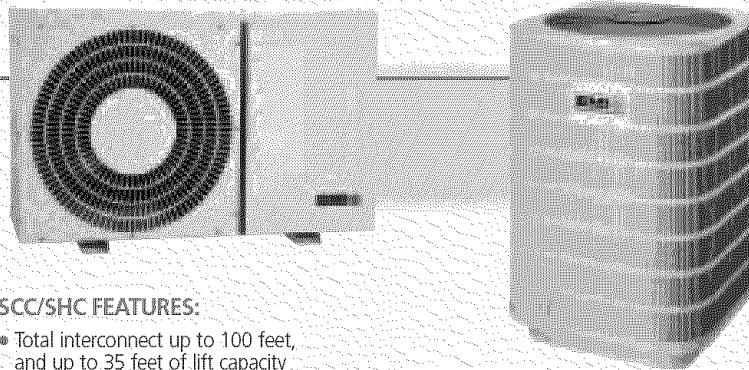

SCC/SHC FEATURES:

- Total interconnect up to 100 feet, and up to 35 feet of lift capacity
- 24Volt interconnect to AmericaSeries air handlers
- G-60 Galvanized steel cabinets
- Duratec Performance Package for 9, 12 and 15,000 BTU/h models with high efficiency rotary compressors
- The 18-36,000 BTU/h models utilize high reliability reciprocating compressors
- 208/230 standard voltage
- Hard start assist (straight cool models only)
- Anti short cycle protection
- Sea coast coated coils

C10 FEATURES:

- Total interconnect up to 100 feet, and up to 35 feet of lift capacity for flexibility in installation
- 208/230 standard voltage

EMI UNIQUE FEATURE OPTION FOR SCC/SHC & C10 LOWER COOLING APPLICATIONS:

- Standard cooling down to 60°F (outside temperature). Expanded low ambient cooling operation down to 0°F (outside temperature) with EMI Low Ambient Kit used with an AmericaSeries Air Handler & Condenser.

Duratec Performance Package

Rotary Compressor Protection

Protects and extends the life of the high efficiency rotary compressors used in the SCC/SHC and MC/MH low tonnage models (09, 12, & 15). 18-36,000 BTU/h compressors use a resettable high pressure safety switch.

- Oversized suction accumulator with surge baffles and oil management (SCC/SHC & MC/MH).
- Factory installed solid core filter dried (SCC & MC).
- Factory installed bi-flow type filter dried (SHC & MH)
- Loss of charge protection (SCC/SHC & MC/MH).
- Manual reset high pressure switch (SHC & MH).
- Zero degree heat pump cut-off switch (SHC & MH).
- Crankcase heater when low ambient option is included (SHC & MH).

MC2/4 & MH2/4

Multi-Zone Condensing Units

MODEL	COOLING Nom. BTU/H	HEAT PUMP CAPACITY	DIMENSIONS		
			L	H	D
MC2/MH2 09	9,500	8,800	44	26 1/4	14
MC2/MH2 12	11,300	10,500	44	26 1/4	14
MC2/MH2 15	14,200	13,400	44	26 1/4	14
MC4/MH4 09	9,400	8,000	34 1/4	29	25
MC4/MH4 12	11,200	10,000	34 1/4	29	25
MC4/MH4 15	14,200	13,600	34 1/4	29	25
MC4/MH4 18	17,100	16,000	34 1/4	29	25
MC4/MH4 24	22,400	20,800	34 1/4	29	25
MC4/MH4 30	28,600	26,500	34 1/4	29	25

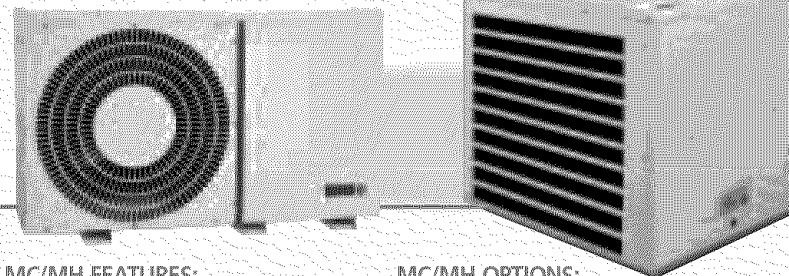

MC/MH FEATURES:

- Total interconnect to each air handler of up to 100 feet, and up to 35 feet of lift for flexibility in installation
- Separate compressors and coil sections for each circuit
- Independent circuit control
- Independent refrigerant piping
- 24v interconnect to air handlers
- G-60 Galvanized Steel Cabinet

MC/MH OPTIONS:

- Standard cooling down to 60°F (outside temperature). Expanded low ambient cooling operation down to 0°F (outside temperature) with EMI Low Ambient Kit used with an AmericaSeries Air Handler & Condenser.
- 208/230 standard voltage / 265 volt option available
- Hard start Assist
- Anti-Short cycle Protection
- Sea Coast Coils

Available Zone Capacity Combinations

MODEL*	ZONES	ZONE CAPACITY COMBINATIONS**				
MC2/MH2	2 Zones	99	92	22	55	
MC4/MH4	2 Zones	908	208	904	0808	204
		0804	503	0404	0303	
MC4/MH4	3 Zones	999	992	922	9908	222 9208
		9904	2208	9204	555	2204 5503
MC4/MH4	4 Zones	9999	9992	9922	9222	2222 5555

MODEL*	ZONES	ZONE CAPACITY COMBINATIONS**				
MC4 (Cooling Only)	2 Zones	903	203	0403	504	0803
MC4 (Cooling Only)	3 Zones	995	955	9504	9903	225 5508
		925	9203	2504	5504	2203 5503
MC4 (Cooling Only)	4 Zones	9955	9225	9255	9995	
		2225	2255	9555		

* Key To Model Code
M = Multi-zone
C = Straight Cool
H = Limited Range Heat Pump
2 = Side Discharge Cabinet
4 = Top Discharge Cabinet

** Numeric Suffixes for Zone Capacities
9 = 9,000 04 = 24,000
08 = 18,000 5 = 15,000
2 = 12,000 03 = 30,000

EXAMPLE: 99 = Two 9,000 BTU/h independent zone circuits
For specific circuit capacities, refer to EMI's Specification and Performance Guide



An ECR International Brand

Enviromaster International LLC
5780 Success Drive • Rome, NY 13440
Phone: 800-228-9364 • Fax: 800-232-9364
Web: www.enviromaster.com
E-Mail: emi@enviromaster.com

An ISO 9001-2000 Certified Company

For complete product information, please refer to individual unit specifications, installation and operation manual, and other product literature. Due to on-going product development specifications are subject to change without notice.



A Participating Company in the ARI 210/240-90 Certification Program