



ARINC 781 SDU, SCM, and FMPA

System Description, Installation, and Maintenance Manual

MN-1394-10078, Revision 001

This document provides procedures for the equipment listed below.

Model	Part Number
ARINC 781 Satellite Data Unit	1394-A-1100
ARINC 781 Flange Mounted High Power Amplifier	1394-A-1200
ARINC 781 SDU Configuration Module	1394-A-1300

PROPRIETARY STATEMENT

This document contains information which is proprietary and confidential to EMS Aviation (EMS Technologies Canada, Ltd., Formation Inc., Sky Connect LLC). Neither this document nor the information contained within may be used for any purpose other than the purpose for which it was prepared. Neither this document nor the information contained within may be disclosed or copied without the prior written permission of EMS Aviation.

© 2010 EMS Technologies Canada, Ltd., Formation Inc., Sky Connect LLC. All Rights Reserved.

ARINC 781 SDU, SCM, and FMPA System Description, Installation, and Maintenance Manual

Document Number: MN-1394-10078, Revision 001

Revision Table		
Revision	ECR	Description
001	N/A	First release.

Windows® is a registered trademark of Microsoft Corporation in the United States and other countries. Other product, brand, service, and company names herein are the trademarks of their respective owners.

Our products are under continuous research and development. Any information may therefore be changed without prior notice. EMS Aviation reserves the right to make improvements or changes in the product described in this manual at any time without notice. While reasonable efforts have been made in the preparation of this document to assure its accuracy, EMS Aviation assumes no liability resulting from any errors or omissions in this document, or from the use of the information contained herein.

Printed in Canada.

EMS Aviation

400 Maple Grove Road, Ottawa, Ontario, K2V 1B8, CANADA

EMS Aviation Reception: (613) 591-9064

EMS Aviation Product Support: (888) 300-7415 (calls are routed to an on-call Product Support specialist after regular business hours)

+44 1684 290 020 (UK)

(613) 591-3086 (outside North America)

EMS Aviation E-mail Help: support@emsaviation.com

EMS Aviation Web site: www.emsaviation.com

EMS Aviation Sales and Marketing: 800-600-9759

CUSTOMER RESPONSE FORM

To help us improve the quality of our product documentation, EMS Aviation would appreciate your comments and suggestions on this publication. Please complete the following customer survey and send to EMS Aviation at:

EMS Aviation
400 Maple Grove Road
Ottawa, ON K2C 0P9

E-mail: techdocs@emsaviation.com

Publication information:

Publication number:	MN-1394-10078
Publication title:	ARINC 781 SDU, SCM, and FMPA System Description, Installation, and Maintenance Manual
Latest issue date:	16 APR 10
Document revision:	001

Customer information:

Name:	
Company:	
Tel:	
Fax:	
Email:	

Comments and suggestions:

Date: _____

Comments: _____

Blank Page

23-15-30

CR-2
16 APR 10

Blank Page

Blank Page

Blank Page

TABLE OF CONTENTS

INTRODUCTION

1. Illustration of Equipment	INTRO-1
2. Acronyms and Abbreviations.....	INTRO-2
3. Safety Advisories	INTRO-4

SYSTEM DESCRIPTION

1. Inmarsat System Overview.....	1-1
2. Equipment Overview	1-2
A. SDU	1-3
B. SCM	1-3
C. FMPA	1-4
3. Equipment Specifications.....	1-4
4. System Interfaces.....	1-7
A. SDU	1-8
B. SCM	1-9
C. FMPA	1-9
5. User Interfaces.....	1-10
A. MCDU	1-10
B. 4-Wire Audio	1-10
C. Ethernet	1-10
D. POTS	1-10
E. CEPT-E1	1-11
F. ISDN	1-11
G. Maintenance Port	1-11
H. LEDs	1-11
I. Self-Test Button	1-11
6. Software Description.....	1-12

SYSTEM OPERATION

1. Using the ARINC 781 Avionics System.....	2-1
A. Operating the MCDU	2-1
(1) Output Ports	2-1

**SYSTEM DESCRIPTION, INSTALLATION, AND MAINTENANCE MANUAL
ARINC 781 SDU, SCM, and FMPA**

(2) Input Ports.....	2-1
(3) Screen.....	2-1
(4) Keyboard.....	2-2
(5) Special Symbols.....	2-2
(6) Navigating the MCDU	2-3
B. Logging On and Off	2-4
(1) Logging On Automatically	2-4
(2) Logging On Manually	2-5
(3) Logging Off.....	2-5
(4) Viewing Log Status.....	2-5
C. Making Cockpit Calls	2-6
(1) Making Calls from the Telephone Directory	2-6
(2) Ending Calls.....	2-8
D. Viewing BITE Information	2-8

INSTALLATION

1. Advisories	3-1
2. Pre-Installation Inspection	3-1
A. Unpacking and Inspecting Equipment	3-1
B. Cabling Notes	3-1
3. Installation Procedure.....	3-2
4. Connection Details.....	3-2
A. SDU	3-2
B. SCM	3-4
C. FMPA	3-4
5. Installation and Engineering Drawings	3-6
A. Outline and Installation Drawings	3-6
B. System Interconnect Drawings	3-6

TEST AND FAULT ISOLATION

1. Operational and Diagnostic Testing	4-1
A. General	4-1
B. Test and Fault Isolation Equipment Requirements	4-1
C. SDU MPU	4-2
(1) Connecting to the MPU.....	4-2
(2) Using the SDU MPU	4-3

**SYSTEM DESCRIPTION, INSTALLATION, AND MAINTENANCE MANUAL
ARINC 781 SDU, SCM, and FMPA**

(3) Menu Item Descriptions	4-4
D. Operational and Diagnostic Test Procedures	4-6
(1) Test Setup Procedure.....	4-7
(2) Post Test	4-7
(3) Installation and Operational Verification Tests	4-7
2. Troubleshooting and Fault Isolation	4-8
A. Subsystem Health	4-8
B. SATCOM System Bus	4-10
C. Thermal Status	4-11
D. SCM Health	4-12
E. Subsystem Bus Status	4-14
F. RF Path Status	4-14
G. USIM and Data Bus Status	4-15
H. ORT	4-16
(1) ORT Use and Storage.....	4-16
(2) Checking the ORT.....	4-17
I. Contact Product Support	4-17
3. Adjustment/Alignment Procedures	4-18
4. Modification History	4-18

MAINTENANCE AND REPAIR

1. Maintenance.....	5-1
2. Repair	5-1
3. Instructions for Continued Airworthiness	5-1
A. Airworthiness Limitations	5-2
B. Electrical and Mechanical Inspection and Check	5-2
C. Instructions for Continued Airworthiness	5-2
4. Visual Inspection and Check.....	5-3
APPENDIX A: RETURN MATERIAL AUTHORIZATION	A-1
1. Warranty Returns	A-1
2. Non-Warranty Returns	A-1
3. Repackaging Requirements	A-1
4. RMA Procedure	A-1

Blank Page

LIST OF FIGURES

Figure INTRO-1 Satellite Data Unit.....	INTRO-1
Figure INTRO-2 SDU Configuration Module.....	INTRO-2
Figure INTRO-3 Flange Mounted Power Amplifier	INTRO-2
Figure 1-1 Simplified Aeronautical Satellite Communications System	1-2
Figure 1-2 ARINC 781 Avionics System	1-3
Figure 1-3 ARINC 781 Avionics System Block Diagram.....	1-8
Figure 1-4 FMPA Block Diagram	1-10
Figure 2-1 MCDU Screen	2-2
Figure 2-2 MCDU Menus.....	2-3
Figure 3-1 ARINC 781 SDU Outline and Installation Drawing, 1394-E-1100 Rev B00 (Sheet 1 of 2)	3-7
Figure 3-2 ARINC 781 SDU Outline and Installation Drawing, 1394-E-1100 Rev B00 (Sheet 2 of 2)	3-9
Figure 3-3 ARINC 781 FMPA Outline and Installation Drawing, 1394-E-1200 Rev D00 (Sheet 1 of 2).....	3-11
Figure 3-4 ARINC 781 FMPA Outline and Installation Drawing, 1394-E-1200 Rev D00 (Sheet 2 of 2).....	3-13
Figure 3-5 ARINC 781 SCM Outline and Installation Drawing, 1394-E-1300 Rev B00 (Sheet 1 of 2)	3-15
Figure 3-6 ARINC 781 SCM Outline and Installation Drawing, 1394-E-1300 Rev B00 (Sheet 2 of 2)	3-17
Figure 3-7 ARINC 781 System Interconnect Drawing, 1394-B-1001 Rev A00 (Sheet 1 of 3)	3-19
Figure 3-8 ARINC 781 System Interconnect Drawing, 1394-B-1001 Rev A00 (Sheet 2 of 3)	3-21
Figure 3-9 ARINC 781 System Interconnect Drawing, 1394-B-1001 Rev A00 (Sheet 3 of 3)	3-23
Figure 4-1 Maintenance Cable.....	4-2
Figure 4-2 Menu 1 Screen Display	4-4
Figure 4-3 Menu 2 Screen Display	4-5
Figure 4-4 Menu 3 Screen Display	4-5
Figure 4-5 SATCOM Subsystem Health Menu	4-9
Figure 4-6 SATCOM System Bus Menu	4-10
Figure 4-7 SATCOM Overtemp Menu	4-12
Figure 4-8 SATCOM SCM Menu	4-13
Figure 4-9 SATCOM Subsystem Bus Menu	4-14

**SYSTEM DESCRIPTION, INSTALLATION, AND MAINTENANCE MANUAL
ARINC 781 SDU, SCM, and FMPA**

Figure 4-10 SATCOM RF Path Menu, System with FMPA..... 4-15
Figure 4-11 SATCOM USIM/DATA Menu 4-16

LIST OF TABLES

Table 1-1 SDU Physical Characteristics and Specifications	1-4
Table 1-2 SCM Physical Characteristics and Specifications	1-5
Table 1-3 External FMPA Physical Characteristics and Specifications	1-6
Table 1-4 ARINC 781 System RTCA/DO-160E Environmental Characteristics	1-7
Table 1-5 SDU System Interfaces	1-9
Table 1-6 SDU LED Status	1-11
Table 2-1 ARINC 781 System Log Status	2-5
Table 3-1 SDU Rear Connector Pin Deviations	3-3
Table 3-2 SDU Front Connector DSUB and RJ45 Pin Assignment	3-3
Table 3-3 SCM D-Type Connector Pin Assignment	3-4
Table 3-4 FMPA J1 Connector Pin Assignments	3-5
Table 4-1 List of Required Test Equipment	4-2
Table 4-2 Maintenance Port Connection Settings	4-3
Table 4-3 Menu 1 Item Descriptions	4-4
Table 4-4 Menu 2 Item Descriptions	4-5
Table 4-5 Menu 3 Item Descriptions	4-6
Table 4-6 Test Setup Procedure	4-7
Table 4-7 Post Test Procedure	4-7
Table 4-8 Power-On Test Procedure	4-8
Table 4-9 SATCOM Subsystem Health Menu	4-9
Table 4-10 Bus Status Indicators	4-10
Table 4-11 SATCOM OVERTEMP Menu	4-12
Table 4-12 SATCOM SCM Menu	4-13
Table 4-13 SATCOM SUBSY BUS Menu	4-14
Table 4-14 SATCOM RF PATH Menu	4-15
Table 4-15 SATCOM USIM/DATA Menu	4-16

Blank Page

INTRODUCTION

This manual provides the specifications, principles of operation, and information necessary to install the ARINC 781 SATCOM Avionics System, including the Satellite Data Unit (SDU), SDU Configuration Module (SCM), and Flange Mounted High Power Amplifier (FMPA).

This document is divided into the following sections:

- System Description
- System Operation
- Installation
- Test and Fault Isolation
- Maintenance and Repair

NOTE: An Illustrated Parts List is not included with this manual.

Only qualified avionics personnel who are knowledgeable in the technical and safety issues related to the installation of aircraft communications equipment should perform the installation procedures provided in this manual.

This manual includes general installation guidelines only; it is not intended to provide specific procedures for every type of installation.

If necessary, the information in this manual will be revised. Before attempting the installation procedures presented in this manual, verify that you have a complete and up-to-date release of this document.

1. Illustration of Equipment

Figure INTRO-1 shows the SDU.

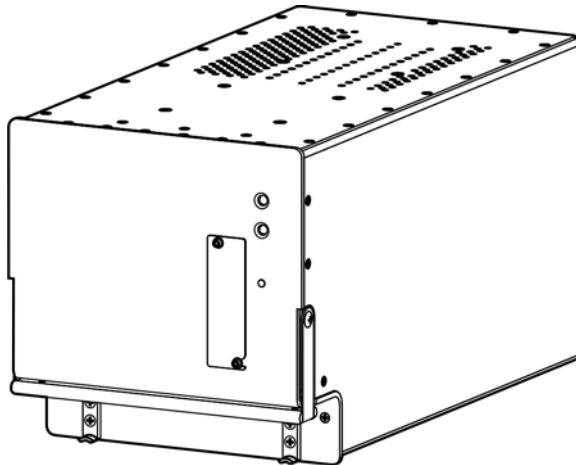

Figure INTRO-1 Satellite Data Unit

**SYSTEM DESCRIPTION, INSTALLATION, AND MAINTENANCE MANUAL
ARINC 781 SDU, SCM, and FMPA**

Figure INTRO-2 shows the SCM.

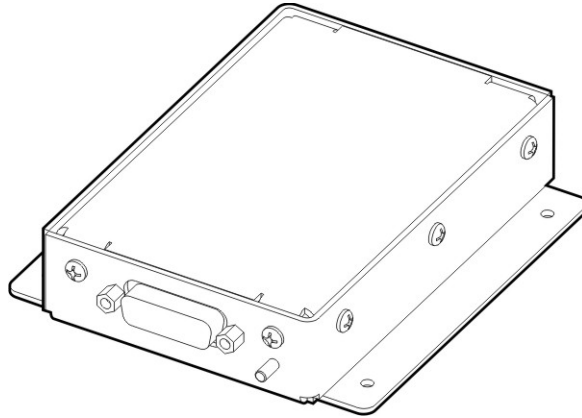

Figure INTRO-2 SDU Configuration Module

Figure INTRO-3 shows the FMPA.

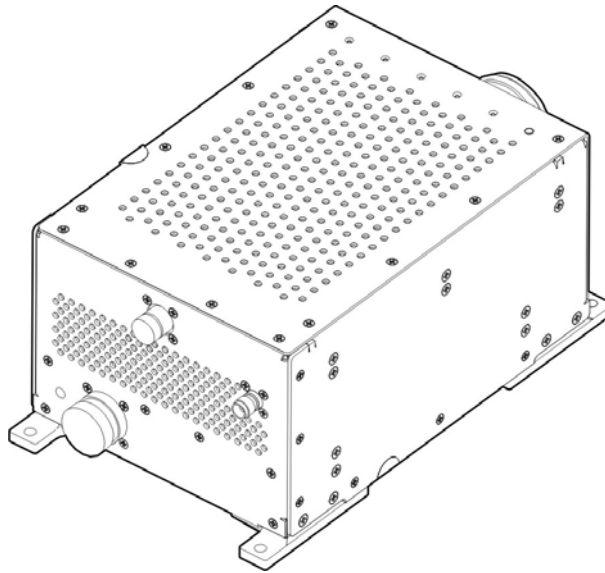

Figure INTRO-3 Flange Mounted Power Amplifier

2. Acronyms and Abbreviations

AES	Aircraft Earth Station
AMSS	Aeronautical Mobile Satellite Services

**SYSTEM DESCRIPTION, INSTALLATION, AND MAINTENANCE MANUAL
ARINC 781 SDU, SCM, and FMPA**

AORE	Atlantic Ocean Region-East
AORW	Atlantic Ocean Region-West
APAC	Asia-Pacific
BIT	Built-In-Test
BITE	Built-In-Test Equipment
BSU	Beam Steering Unit
CEPT-E1	Comite Europeen des Postes et Telecommunications
CTU	Cabin Telecommunications Unit
DLNA	Diplexer/Low-Noise Amplifier
DITS	Digital Information Transfer System
EASA	European Aviation Safety Agency
EMEA	Europe, Middle East, and Africa
ESD	Electrostatic Discharge
FAA	Federal Aviation Administration
FAR	Federal Aviation Regulation
FMPA	Flange Mounted High Power Amplifier
FMS	Flight Management System
GES	Ground Earth Station
GND	Ground
HGA	High Gain Antenna
HPA	High Power Amplifier
ICA	Instructions for Continued Airworthiness
ICAO	International Civil Aviation Organization
I/O	Input/Output
IOR	Indian Ocean Region
IRS	Inertial Reference System
ISDN	Integrated Services Digital Network
LES	Land Earth Station
LRU	Line Replaceable Unit
MCDU	Multi-purpose Control Display Unit
MCU	Modular Concept Unit

**SYSTEM DESCRIPTION, INSTALLATION, AND MAINTENANCE MANUAL
ARINC 781 SDU, SCM, and FMPA**

MES	Mobile Earth Station
MHz	Megahertz
MOPS	Minimum Operational Performance Standards
MPU	Maintenance Port Utility
ORT	Owner Requirement Table
POR	Pacific Ocean Region
POTS	Plain Old Telephone System
RF	Radio Frequency
RMA	Return Material Authorization
RTN	Return
Rx	Receive
SATCOM	Satellite Communications
SBB	SwiftBroadband (Inmarsat)
SCM	SDU Configuration Module
SDU	Satellite Data Unit
SLU	Software Logical Unit
STC	Supplemental Type Certificate
Tx	Transmit
USIM	Universal Subscriber Identity Module
UUT	Unit Under Test
VSWR	Voltage Standing Wave Ratio

3. Safety Advisories

Warnings, cautions, and notes in this manual provide the reader with the following information:

- A **WARNING** describes an operation, procedure, or condition that, if not obeyed, could cause injury or death.
- A **CAUTION** describes an operation, procedure, or condition that, if not obeyed, could cause damage to the equipment.
- A **NOTE** provides supplementary information or explanatory text that makes it easier to

**SYSTEM DESCRIPTION, INSTALLATION, AND MAINTENANCE MANUAL
ARINC 781 SDU, SCM, and FMPA**

understand and perform procedures.

All personnel who install, operate, and maintain the ARINC 781 SDU, SCM, FMPA, and associated test equipment must know and obey the safety precautions listed below. The procedures provided in this manual assume that the person performing installation or maintenance tasks is familiar with and obeys standard aviation shop and safety practices.

The general safety advisories include the following:

WARNING: THE ARINC 781 AVIONICS SYSTEM INCLUDES COMPONENTS THAT RADIATE RF AND MICROWAVE EMISSIONS IN THE BANDWIDTH OF 1626.5 TO 1660.5 MHZ.

WARNING: BEFORE HANDLING ANY UNIT OR COMPONENT, GROUND THE REPAIR OPERATOR THROUGH A CONDUCTIVE WRIST STRAP OR OTHER DEVICE THAT USES A 470 KILOHM OR 1 MEGAOHM SERIES RESISTOR TO PREVENT INJURY.

CAUTION: TURN OFF POWER BEFORE DISCONNECTING ANY EQUIPMENT FROM WIRING. DISCONNECTING THE EQUIPMENT WITHOUT TURNING POWER OFF MAY CAUSE VOLTAGE TRANSIENTS THAT CAN DAMAGE THE EQUIPMENT.



ATTENTION
OBSERVE PRECAUTIONS
FOR HANDLING
ELECTROSTATIC
SENSITIVE DEVICES

CAUTION: THIS EQUIPMENT INCLUDES ITEMS THAT ARE ELECTROSTATIC DISCHARGE SENSITIVE (ESDS) DEVICES. ESDS DEVICES ARE SUBJECT TO DAMAGE BY EXCESSIVE LEVELS OF VOLTAGE AND/OR CURRENT. THE LOW-ENERGY SOURCE THAT MOST COMMONLY DESTROYS ESDS DEVICES IS THE HUMAN BODY, WHICH, IN CONJUNCTION WITH NONCONDUCTIVE GARMENTS AND FLOOR COVERINGS, GENERATES AND RETAINS STATIC ELECTRICITY. TO ADEQUATELY PROTECT ESDS DEVICES, THE DEVICE AND EVERYTHING THAT CONTACTS IT MUST BE BROUGHT TO GROUND POTENTIAL BY PROVIDING A CONDUCTIVE SURFACE AND DISCHARGE PATHS. USE STANDARD INDUSTRY PRECAUTIONS TO KEEP RISK OF DAMAGE TO A MINIMUM WHEN TOUCHING, REMOVING, OR SERVICING THE EQUIPMENT.

Blank Page

SYSTEM DESCRIPTION

This section includes basic information about the ARINC 781 avionics system, including the following sections:

- Inmarsat System Overview
- Equipment Overview
- Equipment Specifications
- System Interfaces
- User Interfaces
- Software Description

1. Inmarsat System Overview

This section provides an overview of the Inmarsat satellite communications system and networks.

Satellite communication systems provide users with long-range voice and data communication by accessing global satellite and ground communications networks. Satellite communication systems include global satellite networks, Land Earth Stations (LESs), Ground Earth Stations (GESs), Aircraft Earth Stations (AESs), and Mobile Earth Stations (MESs).

The LES/GES is the part of the satellite communication system that is on the ground. These numerous, international stations are responsible for routing voice and data calls from the MES/AES to their destinations around the world. The MES/AES is the part of the satellite communication system that is on the aircraft. GES and AES are the terms associated with Aero-H+ services. LES and MES are terms associated with other satellite communication services.

Inmarsat is an international organization that operates and maintains multiple geostationary satellites and satellite networks (I-3 and I-4). For more information about I-3 and I-4 satellite beam coverage, refer to the Inmarsat website—www.inmarsat.com.

I-3 satellites provide Inmarsat services for aviation (Aero H+ and Swift 64), shipping, and land-mobile users. The satellites connect to ground telecommunication systems through a network of GESs. Each I-3 satellite is located over an Ocean Region (OR)—the current OR names are:

- Atlantic Ocean Region-East (AOR-E)
- Atlantic Ocean Region-West (AOR-W)
- Indian Ocean Region (IOR)
- Pacific Ocean Region (POR)

**SYSTEM DESCRIPTION, INSTALLATION, AND MAINTENANCE MANUAL
ARINC 781 SDU, SCM, and FMPA**

In addition to the services offered by I-3 satellites, the I-4 satellites provide worldwide SwiftBroadband (SBB service). Each I-4 satellite has 19 wide spot beams, 228 narrow spot beams, and is capable of accommodating many separate, simultaneous SBB sessions. The SBB service and I-4 satellites support broadband applications such as video conferencing. The current I-4 satellites are:

- AMERICAS
- EMEA (Europe, Middle East, and Africa)
- APAC (Asia-Pacific)

The satellite communication avionics (ARINC 781 systems), typically in conjunction with an antenna subsystem, act as an AES/MES. The combined system provides users with a data and voice communications link to the satellite network and global telecommunications system.

Figure 1-1 illustrates a simplified satellite communications system.

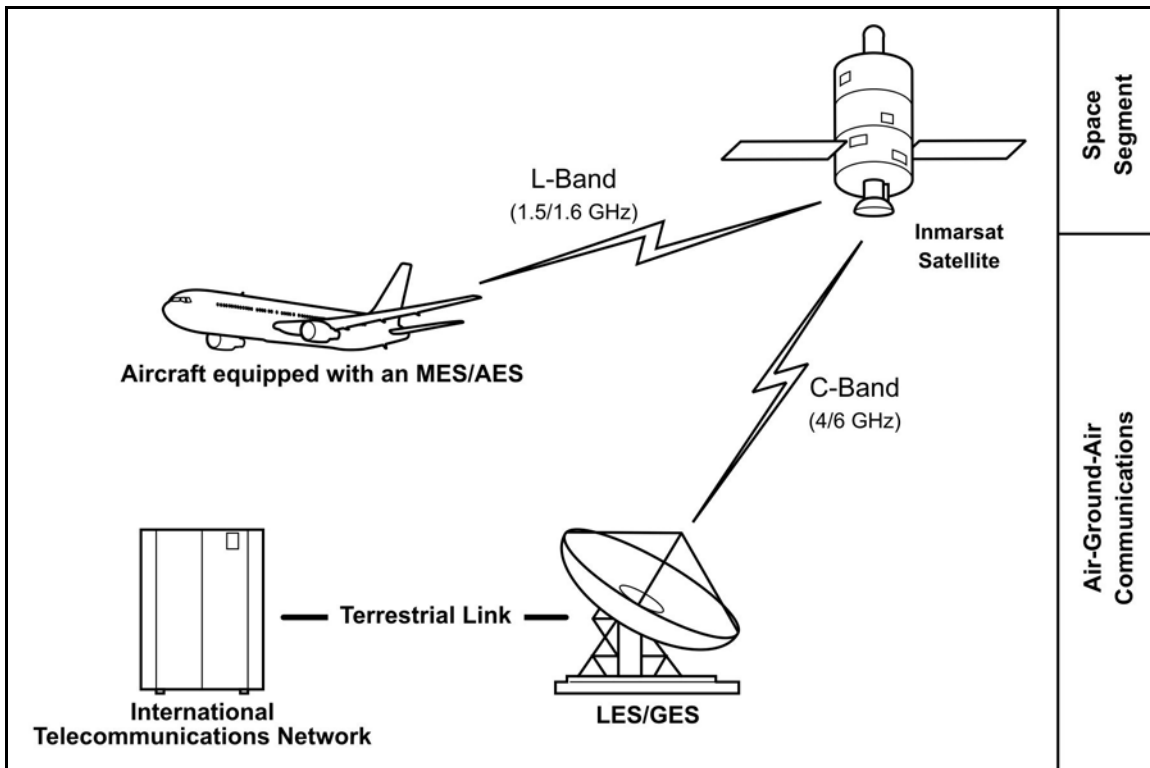

Figure 1-1 Simplified Aeronautical Satellite Communications System

2. Equipment Overview

The ARINC 781 SATCOM Avionics System, in combination with the antenna sub-system, provides Aeronautical Mobile Satellite Services (AMSS) by facilitating airborne satellite communications over the Inmarsat network, including the following services:

**SYSTEM DESCRIPTION, INSTALLATION, AND MAINTENANCE MANUAL
ARINC 781 SDU, SCM, and FMPA**

- Classic Aero-H+—Provides packet data services at 600 bps, 1200 bps, or 10500 bps over the PRT channel combination and half-rate circuit switched voice or data service over the C channel.
- Swift 64—Provides packet switched Mobile Packet Data Service (MPDS).
- SwiftBroadband—Provides AMBE+2 voice (circuit-switched) and broadband packet switched services. The equipment can achieve aggregate rates of 432 kbps, but data rates may vary with network load.

The ARINC 781 SATCOM Avionics System consists of the Satellite Data Unit (SDU), the Satellite Data Unit Configuration Module (SCM), and optionally, the Flange Mount Power Amplifier (FMPA).

Figure 1-2 illustrates the ARINC 781 avionics system.

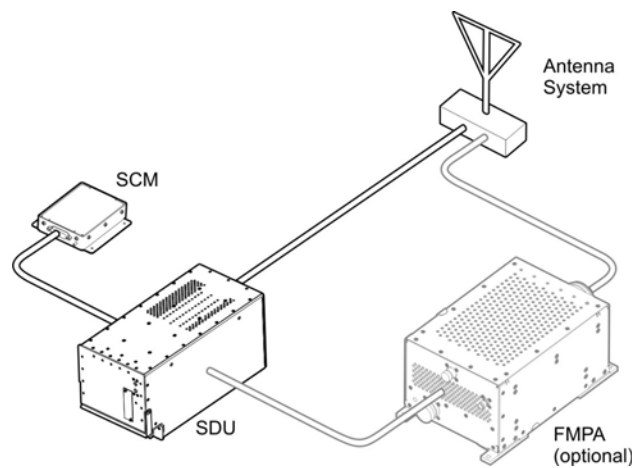

Figure 1-2 ARINC 781 Avionics System

A. SDU

The SDU is the central communications processing and control unit and largely determines the functionality of the complete SATCOM system. It manages interfaces, routing and priorities, and call channel establishment and tear down. When configured without an FMPA, the SDU provides RF power amplification using an internal high power amplifier (HPA).

The SDU is divided into several Shop Replaceable Units (SRUs) that are electrically connected via the backplane. Various SRUs are also connected using RF cables.

B. SCM

The SCM is an external peripheral of the SDU and provides a dedicated interface to the SDU. It stores Secure and User ORTs (Owner Requirement Tables) and a Swift 64 Forward ID. The SCM can accommodate up to four Universal Subscriber Identity Modules (USIM) that store subscriber information for the SBB network.

**SYSTEM DESCRIPTION, INSTALLATION, AND MAINTENANCE MANUAL
ARINC 781 SDU, SCM, and FMPA**

By storing configuration information independent of the SDU, the SCM facilitates efficient SDU replacement. A new SDU that replaces a faulty SDU does not require any configuration. All configuration information is obtained from the SCM.

C. FMPA

The FMPA is an optional component that provides amplification for configurations requiring an external HPA. It is managed by the SDU and provides the final radio frequency amplification in the AES system. The FMPA is divided into three SRUs—power supply, control processor, and power amplifier. An overall packaging system encloses the SRUs and the physical connections between them.

3. Equipment Specifications

This section includes the physical and environmental characteristics of the ARINC 781 SDU, SCM, and FMPA.

Table 1-1 provides a summary of the physical characteristics and equipment specifications of the SDU component.

Table 1-1 SDU Physical Characteristics and Specifications

CHARACTERISTIC	SPECIFICATION
RELATED DOCUMENTS	
ARINC characteristics	ARINC 781 Mark 3 Aviation Satellite Communications System ARINC 600 Air Transport Avionics Equipment Interfaces
RTCA documents	DO-254, Design Assurance Guidance for Airborne Electronic Hardware DO-178B, Software Considerations in Airborne Systems and Equipment Certification DO-160E, Environmental Conditions and Test Procedures for Airborne Equipment DO-210, Minimum Operational Performance Standards (MOPS) for Geosynchronous Orbit Aeronautical Mobile Satellite Services (AMSS) Avionics
SDU SPECIFICATIONS	
Physical Size	
Length	37.24 cm (14.66 in)
Width	19.35 cm (7.62 in)
Height	19.93 cm (7.85 in)
Weight	11.35 kg (25.0 lbs)

**SYSTEM DESCRIPTION, INSTALLATION, AND MAINTENANCE MANUAL
ARINC 781 SDU, SCM, and FMPA**

Table 1-1 SDU Physical Characteristics and Specifications (Continued)

CHARACTERISTIC	SPECIFICATION
Heating and Cooling	
Cooling Air	ARINC 600
Flow Rate	50 kg/hr 40°C (max) air
Pressure Drop	5 ± 3 mm H ₂ O
Mounting Information	6 MCU tray as per ARINC 600
Electrical Interfaces	
Power/Control interface	as per ARINC 781
Power Requirements	
Input Voltage (AC)	96 to 122 V AC, 300 to 900 Hz
Input Voltage (DC)	18 to 32.3 V DC
Power Consumption	300 VA if operated with an external FMPA 400 VA if operated as standalone

Table 1-2 provides a summary of the physical characteristics and equipment specifications of the SCM component.

Table 1-2 SCM Physical Characteristics and Specifications

CHARACTERISTIC	SPECIFICATION
RELATED DOCUMENTS	
ARINC characteristics	ARINC 781 Mark 3 Aviation Satellite Communications System
RTCA documents	DO-254, Design Assurance Guidance for Airborne Electronic Hardware DO-160E, Environmental Conditions and Test Procedures for Airborne Equipment
SCM SPECIFICATIONS	
Physical Size	
Length	11.43 cm (4.5 in)
Width	10.16 cm (4.0 in)
Height	2.54 cm (1.0 in)
Weight	0.454 kg (1.0 lbs)

**SYSTEM DESCRIPTION, INSTALLATION, AND MAINTENANCE MANUAL
ARINC 781 SDU, SCM, and FMPA**

Table 1-2 SCM Physical Characteristics and Specifications (Continued)

CHARACTERISTIC	SPECIFICATION
Mounting Information	4 x 0.125" holes on 3.3" x 3.5" spacing, per attachment 1-6 of ARINC 781
Electrical Interfaces	
Power/Control interface	as per ARINC 781
Power Requirements	+ 12 V \pm 5% (derived from SDU)

Table 1-3 provides a summary of the physical characteristics and equipment specifications of the external FMPA component.

Table 1-3 External FMPA Physical Characteristics and Specifications

CHARACTERISTIC	SPECIFICATION
RELATED DOCUMENTS	
ARINC characteristics	ARINC 781 Mark 3 Aviation Satellite Communications System
RTCA documents	DO-178B, Software Considerations in Airborne Systems and Equipment Certification
	DO-160E, Environmental Conditions and Test Procedures for Airborne Equipment
FMPA SPECIFICATIONS	
Physical Size	
Length	32.46 cm (12.78 in)
Width	18.34 cm (7.22 in)
Height	13.72 cm (5.40 in)
Weight	6.81 kg (15.0 lbs)
Mounting Information	4 x 0.266" holes on 11.19" x 6.4" spacing
Electrical Interfaces	
Power/Control interface	ARINC 781
Power Requirements	115 Vrms ac, 300 Hz to 900 Hz
Power Consumption	< 250 VA

Table 1-4 lists the RTCA/DO-160E environmental characteristics of the SDU, SCM, and FMPA.

SYSTEM DESCRIPTION, INSTALLATION, AND MAINTENANCE MANUAL
ARINC 781 SDU, SCM, and FMPA

Table 1-4 ARINC 781 System RTCA/DO-160E Environmental Characteristics

Section	Environmental Condition	Category	
		SDU/SCM	FMPA
4.0	Temperature and Altitude	F2/A2	F2/A2
4.5.1	Ground Survival Low	F2	F2
4.5.1	Short Term Operating Low Ambient	F2	F2
4.5.2	Operating Low Ambient	F2	F2
4.5.3	Ground Survival High	F2	F2
4.5.3	Short Time Operating High	F2	F2
4.5.4	Operating High Ambient	F2	F2
4.5.5	In Flight Loss of Cooling	P	F2
4.6.1	Altitude	F2	F2
4.6.2	Decompression	A2	A2
4.6.3	Overpressure	A2 (modified to -20,000 ft)	A2 (modified to -20,000 ft)
5	Temperature Variation	B	B
6	Humidity	A	A
7	Operational Shock and Crash Safety	B	B
8.5	Vibration Standard – Sine	S, Curves L, M, Y	S, Curves L, M, Y
8.5.2	Vibration Standard – Random	S, Curve B	S, Curve C
8.7.2	Vibration Robust – Random	R, Curves B, B1	R, Curves C, C1
9.0	Explosive Atmosphere	E	E
15	Magnetic Effect	Z	Z
16.5	Power Input (ac)	A(WF)H	A(WF) (modified extended frequency 300 Hz to 900 Hz)
17	Voltage Spike	A	A
18	Audio Frequency Conducted Susceptibility (ac)	K(WF)	K(WF)
19	Induced Signal Susceptibility	CW	CW
20	Radio Frequency Susceptibility	R	R
21	Emission of RF Energy	M	M
22	Lightning Induced Transient Susceptibility	A3J33	A3J33
25	Electrostatic Discharge (ESD)	A	A

4. System Interfaces

This section describes the ARINC 781 system interfaces.

Figure 1-3 illustrates the block diagram of the ARINC 781 avionics system.

**SYSTEM DESCRIPTION, INSTALLATION, AND MAINTENANCE MANUAL
ARINC 781 SDU, SCM, and FMPA**

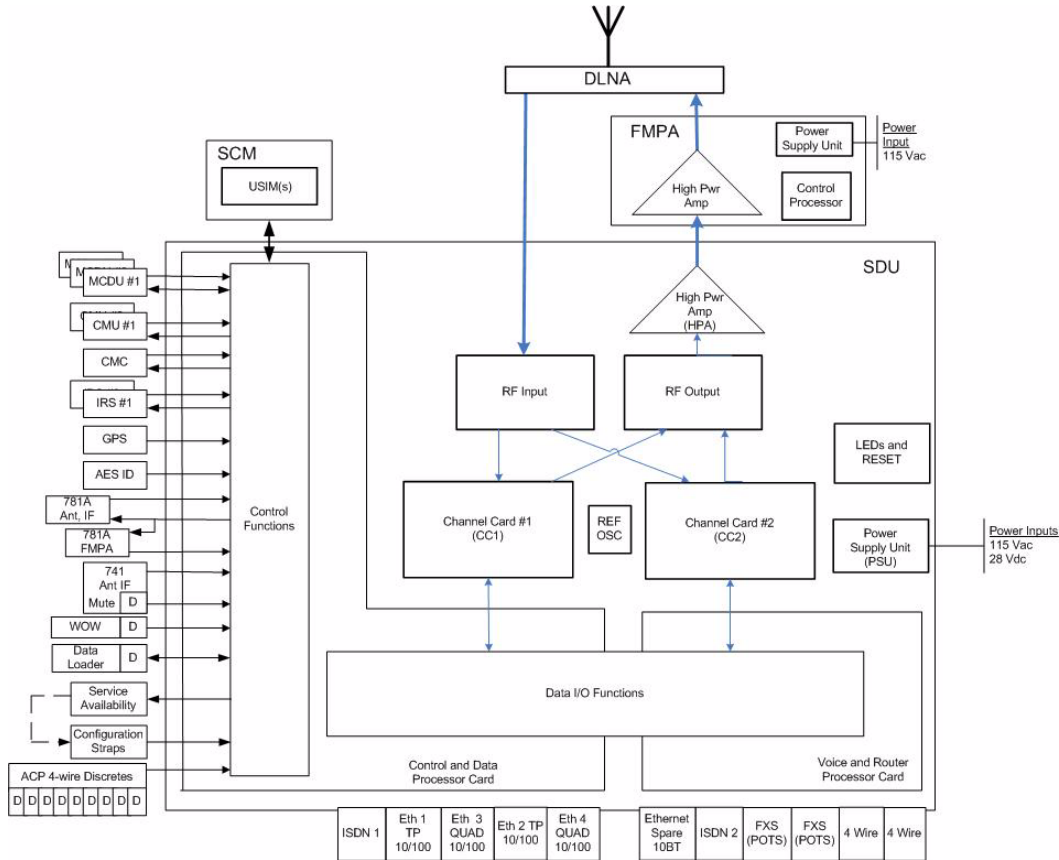

Figure 1-3 ARINC 781 Avionics System Block Diagram

A. SDU

The SDU is divided into the following SRUs:

- Channel Cards (2)
- Control and Data Processor Card
- Voice and Router Processor Card
- Power Amplifier
- ARINC Backplane
- DIN Backplane
- 10 MHz Oven Controlled Crystal Oscillator
- Power Supply

The major interfaces of the SDU are listed in Table 1-5.

Table 1-5 SDU System Interfaces

System Interface	Description
ACU/BSU (x1)	Antenna Control Unit/Beam Steering Unit
FMPA (x1)	Flange Mount Power Amplifier
MCDU (x3)	Multi-Purpose Control and Display Unit
ACARS CMU (x2)	Aircraft Communication Addressing and Reporting System Communication Management Unit
IRS (x2)/GPS (x1)	Inertial Reference System/Global Positioning System
SCM (x1)	SDU Configuration Module
CMC (x1)	Central Maintenance Computer
AES ID (x1)	Aircraft Earth Station Identification
Servicing	Front Panel Accessible Service Port for data log retrieval
Button	Initiated Self-Test
RF	Transmit to the FMPA, Receive from the DLNA
Antenna subsystem	ARINC 781 Antenna Subsystem
Miscellaneous	ARINC discrete input, outputs, and configuration straps

B. SCM

The SCM does not provide any interfaces other than a dedicated interface to the SDU.
The SCM is powered by the SDU.

C. FMPA

The FMPA provides RF multi-carrier amplification capabilities permitting up to 32 W total average RF power. The SDU manages the FMPA, providing the necessary command control. The FMPA has four operational interfaces:

- ARINC 429 Control (x1)/BITE (x1) – FMPA to SDU control and reporting
- RF Input Signal (x1) – RF low power input from the SDU
- RF Output Signal (x1) – RF high power output to the antenna subsystem (DLNA)
- Power Supply (x1) – 115 Vac, 300 Hz to 900 Hz

Figure 1-4 illustrates a block diagram of the FMPA.

**SYSTEM DESCRIPTION, INSTALLATION, AND MAINTENANCE MANUAL
ARINC 781 SDU, SCM, and FMPA**

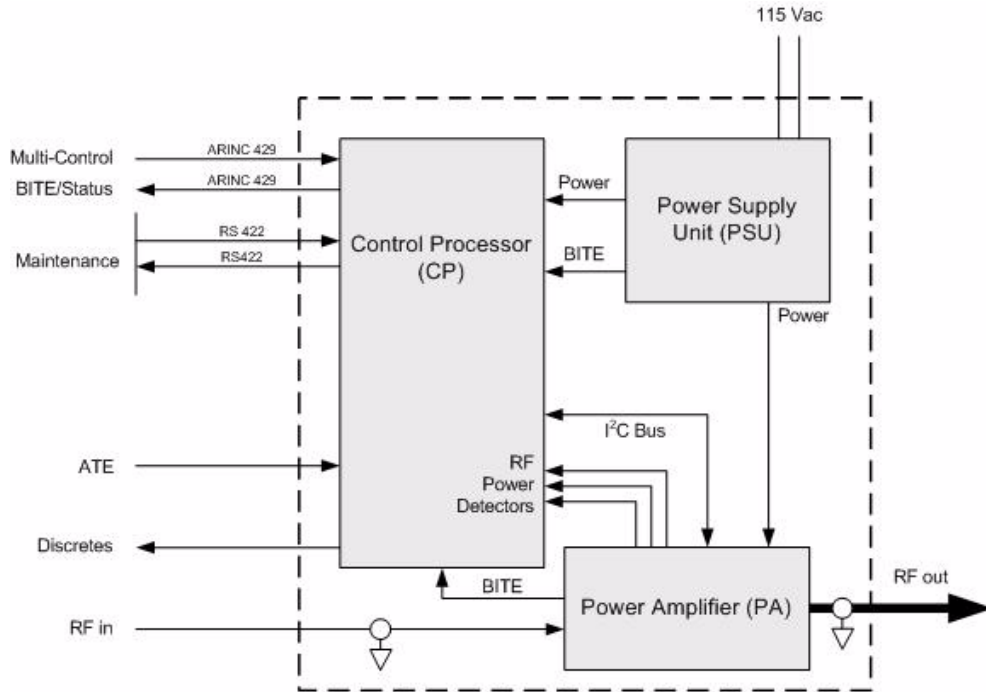

Figure 1-4 FMPA Block Diagram

5. User Interfaces

This section describes the ARINC 781 SDU interfaces that enable users to access Inmarsat services and monitor the operation of the ARINC 781 avionics system.

NOTE: There are no user interface associated with the SCM and FMPA.

A. MCDU

The MCDU is a device that uses an ARINC 429 interface per ARINC 739, which lets you communicate with individual instruments on an aircraft, including the Flight Management System (FMS), very high frequency (VHF) radio, and the SDU.

The SDU supports three MCDUs.

B. 4-Wire Audio

The SDU supports two 4-wire audio interfaces.

C. Ethernet

The SDU supports five Ethernet data interfaces.

D. POTS

The SDU supports two POTS interfaces.

E. CEPT-E1

The SDU supports one CEPT-E1 interface.

F. ISDN

Two ISDN interfaces are currently not supported.

G. Maintenance Port

The SDU is equipped with a maintenance port, located on its front panel. The maintenance port provides the physical connection to a password-protected Maintenance Port Utility (MPU) that provides a system interface for users or service personnel who need to monitor or troubleshoot the system.

For more information on configuring the maintenance port, refer to "Connecting to the MPU" on page 4-2.

H. LEDs

The front panel of the SDU has two LEDs to indicate unit status:

- One green LED labelled **Power**
- One red LED labelled **Fault**

Table 1-6 provides information about the LED signals.

Table 1-6 SDU LED Status

Power LED Status	Fault LED Status	Description of SDU Status
On for 60 seconds, then off during normal operation	Off	No fault detected
Off	On while the fault exists	LRU fault detected
Off	Flashing at 1 Hz with a 50% duty cycle while the fault exists	System fault detected but not isolated to the LRU
Alternating flashing of Power and Fault LEDs		Self-test in progress

I. Self-Test Button

The front panel of the SDU has a recessed button labelled **Test**:

- To reset the unit, press and hold the Test button for at least 5 seconds
- To initiate self-test (when no LEDs are flashing), momentarily press the Test button
- To disable the existing LED condition (when LEDs are flashing), momentarily press the Test button

NOTE: During initial power-up or self-test execution, a momentary press of the self-test button is ignored.

The LEDs indicate the results of the self-test. Table 1-6 provides information about the meaning of LED signals.

6. Software Description

All operating software meets RTCA/DO-178B Level D requirements.

The SCM does not contain any software. Only configurable parameters are stored in the SCM.

All FMPA software is stored in the Control Processor SRU. It manages BITE, data loading, maintenance, and ARINC 429 label transmission and reception.

The SDU software is not partitioned. The software is modular and modules run on individual Software Logical Units (SLUs) within the SDU:

- Each channel card has a single SLU
- Control and Data Processor card has a Control SLU and a Data SLU
- Voice and Router card has a Voice SLU and a Router SLU

SYSTEM OPERATION

The SDU is an integral component in an AES. Together with the SCM, DLNA, Antenna, and HGA subsystem, it provides AMSS by facilitating airborne satellite communication services over the Inmarsat network. These services comprise Classic Aero-H+, Swift 64, and SwiftBroadband (SBB).

The SCM is a dedicated peripheral of the SDU and stores aircraft specific installation configuration critical to the operation of the AES.

The FMPA provides RF multi-carrier amplification capabilities permitting up to 32 W total average RF power. The SDU manages the FMPA, providing the necessary command control.

This section provides basic information on using the ARINC 781 avionics system.

1. Using the ARINC 781 Avionics System

This section describes how to perform the following tasks:

- Operating the MCDU
- Logging On and Off
- Making Cockpit Calls
- Viewing BITE Information

A. Operating the MCDU

This section provides information about the MCDU and its interfaces—output and input ports, the screen, and the keyboard.

(1) Output Ports

The MCDU transfers its identification and commands to the SDU using 32 bit words on a 12-14.5 kbps output port, as defined in ARINC Specification 429, Digital Information Transfer System (DITS).

(2) Input Ports

The MCDU receives identification information and displays data from individual subsystems using seven input ports, as defined by ARINC Specification 429. Ports 1 and 2 are reserved for FMSs, and they operate at 100 kbps. Ports 3–7 are available for the MCDU to communicate with the SDU, and they operate at 12-14.5 kbps.

(3) Screen

The MCDU displays all data on the screen, as shown in Figure 2-1.

**SYSTEM DESCRIPTION, INSTALLATION, AND MAINTENANCE MANUAL
ARINC 781 SDU, SCM, and FMPA**

	1		5		10		15		20		24	
	1				S A T - P H O N E						1 / 2	
					S A T - L : S T A T U S						P R I O R I T Y	
1L	3	<	A C T I O N 1								E M G >	3
			L A B E L 1									
2L	5	<	A C T I O N 2								D I R E C T O R Y >	5
3L	7											7
					S A T - R : S B 4						V O I C E N T A V A I L	
4L	9											9
5L	11											11
6L	13											13

Figure 2-1 MCDU Screen

The top of the screen displays the title of the menu on the screen. The bottom of the screen (Line 14) is the scratchpad that displays information that you enter on the keyboard.

The MCDU has six buttons on each side of the screen that activate MCDU functions. Figure 2-1 displays these buttons on the left and right sides of the screen. When the functions corresponding to a button are available, the function is displayed beside the button.

Other lines on the MCDU screen display information relevant to the function or status of the ARINC 781 system.

(4) Keyboard

The MCDU's keyboard includes a set of numeric keys and a set of alphabetic keys, both of which you can use to enter data into the MCDU.

The keyboard may include preset keys, such as the following:

- The **IDX** or **MAIN MENU** key: this key returns you to the MCDU's main menu.
- The **CLR** key: this key clears any text you type into the scratchpad.
- The **NEXT PAGE** key: this key brings up the next page of a menu if one is available.
- The **PREV PAGE** key: this key brings up the previous page of a menu if one is available.

(5) Special Symbols

Because of space constraints on the screen, the MCDU uses a number of special symbols to indicate actions:

- **<** and **>** appear at the far left or right to indicate that another menu page is available in that direction or that a function is available for that label.

**SYSTEM DESCRIPTION, INSTALLATION, AND MAINTENANCE MANUAL
ARINC 781 SDU, SCM, and FMPA**

- **NUMBER/NUMBER** appears to tell you which page out of how many pages you are viewing. For example, **1/3** would appear when you are on page 1 of 3 pages in total.

(6) Navigating the MCDU

The MCDU includes a number of menus, as shown in Figure 2-2.

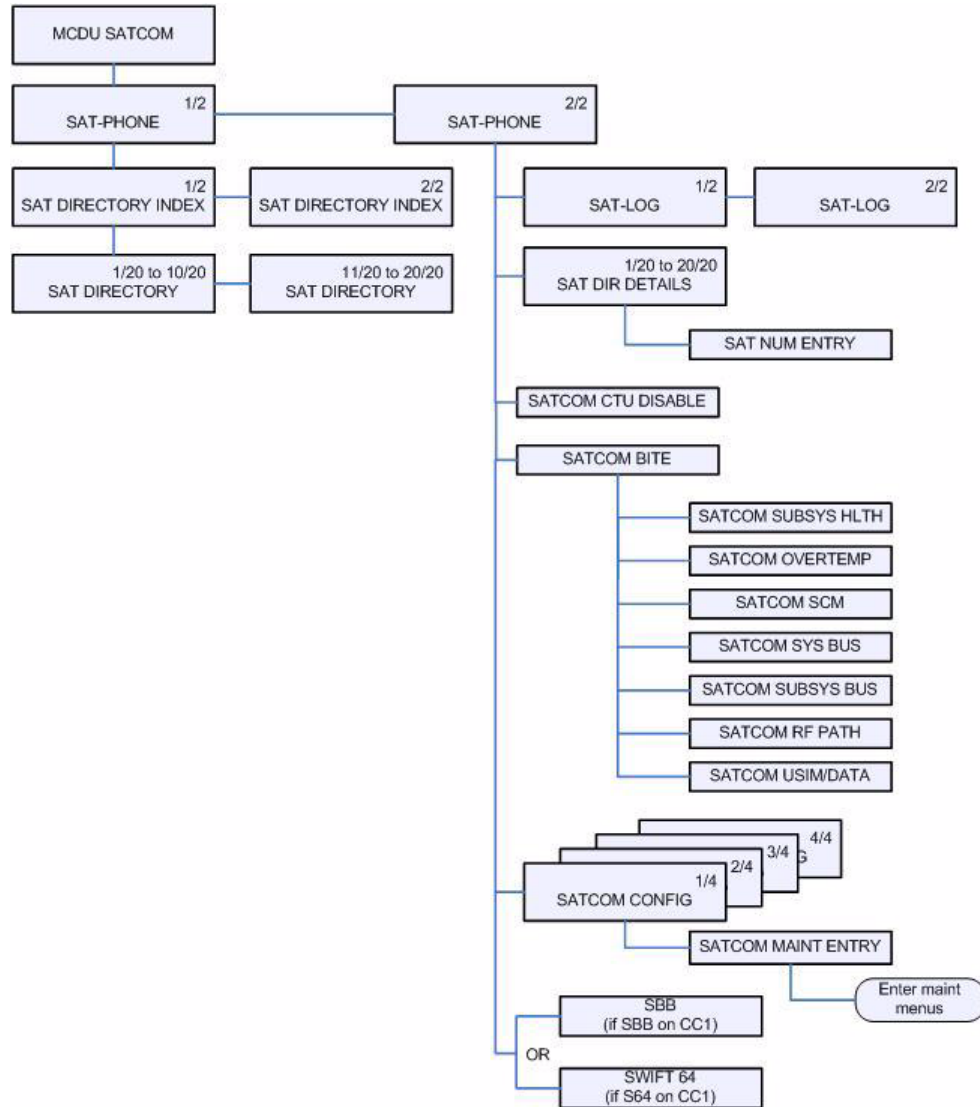

Figure 2-2 MCDU Menus

B. Logging On and Off

Using the MCDU, you can log on to the satellite network manually or automatically:

- Manual Logon—constrains the logon to use a satellite that you select
- Automatic Logon—logs on using the best available satellite as defined by the ORT

If specified in the ORT, the initial system logon happens immediately after the ARINC 781 system powers up, with no MCDU input required. If the ORT is not configured as such, you must initiate the logon from the MCDU (MANUAL LOG-ON or AUTO LOG-ON command).

You can watch the progress of the logon on the SATCOM LOG 1/2 page, or simply wait until the prompt on the SAT-PHONE 1/2 page indicates the service is available for use.

(1) Logging On Automatically

When you initiate an automatic logon, the system selects a satellite and GES based on the preferences specified in the ORT.

To log on automatically:

1. On the SAT-PHONE 1/2 page, press the key next to **LOG**.

The SATCOM LOG page appears.

	1		5		10		15		20		24	
	1				S A T C O M		L O G				1 / 2	1
1L	3											1R
2L	5		S T A T U S					S I G N A L				2R
			L O G G E D		O N			1 0 0			5	
3L	7		S A T E L L I T E		I D			B E A M		I D		3R
			A T L A N T I C		W E S T					2	7	
4L	9		G E S		I D							4R
			G O O N H I L L Y								9	
5L	11										11	5R
6L	13		< R E T U R N					L O G - O F F		>	13	6R

2. On the SATCOM LOG page, press the key next to **AUTO LOG-ON**.

The MCDU returns to the SAT-PHONE 1/2 page and the SAT-L and SAT-R channels are updated with READY status after the logon completes.

NOTE: The MCDU does not display the AUTO LOG-ON and MANUAL LOG-ON functions when the ARINC 781 system is already logged on.

NOTE: On the SAT-PHONE 1/2 page, SAT-L shows the Classic Aero channel status and SAT-R shows the SBB channel status. The ARINC 781 system logs on the Classic Aero channels first, and then logs on the SBB channels.

**SYSTEM DESCRIPTION, INSTALLATION, AND MAINTENANCE MANUAL
ARINC 781 SDU, SCM, and FMPA**

(2) Logging On Manually

To log on manually, you must select a satellite and GES.

To log on manually:

1. On the SAT-PHONE 1/2 page, press the key next to **LOG**.
The SATCOM LOG page appears.
2. Press the key next to **SATELLITE ID** until the MCDU screen shows the satellite ID to which you want the ARINC 781 system to log on.
3. Press the key next to **GES ID** until the MCDU screen shows the GES to which you want the ARINC 781 system to log on.
4. On the SATCOM LOG page, press the key next to **MANUAL LOG-ON**.

The MCDU returns to the SAT-PHONE 1/2 page and updates the SAT-L and SAT-R channels with READY status after the log on completes.

NOTE: SAT-L shows the Classic Aero channel status and SAT-R shows the SBB channel status. The ARINC 781 system logs on the Classic Aero channels first, and then searches for SBB or Swift 64 services on the satellite determined by the Classic Aero log-on.

(3) Logging Off

To log off:

1. On the SAT-PHONE 1/2 page, press the key next to **LOG**.
The SATCOM LOG page appears.
2. On the SATCOM LOG page, press the key next to **LOG-OFF**.
The ARINC 781 system logs off the satellite network.

(4) Viewing Log Status

The log status defines whether the ARINC 781 system is logged on or logged off. Valid values are shown in Table 2-1.

Table 2-1 ARINC 781 System Log Status

Log Status	Description
CALIBRATION	If in FMPA mode, and cable calibration not yet completed
SAFE MODE	Configuration error detected
HSR NOT READY	High stability oscillator is in a warming condition
ANT NOT READY	Antenna is reporting test state
AES ID NOT READY	Displayed until a non-zero ICAO address is present
NAV DATA UNAVAIL	Insufficient navigation data available
CC NOT READY	Channel card has not fully booted
LOGGED OFF	ARINC 781 system not logged on to the satellite network. Awaiting input from the user
TUNING TO SAT	Tuning and scanning for reception from the selected satellite

Table 2-1 ARINC 781 System Log Status (Continued)

Log Status	Description
DET SYS TABLE	Updating the Satellite table
SPOT BEAM SEARCH	Selecting the optimal spot beam
WAIT LOGON CONF	Awaiting the logon confirmation from the satellite
WAIT LOGON ACK	Awaiting for logon acknowledge from the GES
LOGGED ON	Successfully logged on to GES
REJECT-TEMPORARY	Logon rejected by the GES, but the condition is temporary
REJECT-PERMANENT	Logon rejected by the GES, and the condition is permanent
REJECT-INV PARAM	Logon rejected by the GES due to invalid parameters, and the condition is permanent
REJECT-AES INVAL	ICAO address was not accepted by the GES, the condition is permanent
LOGGING OFF	Starting the logoff process

To view log status:

1. On the SAT-PHONE 1/2 page, press the key next to **LOG**.
The SATCOM LOG page appears.
2. The log status appears on the line below **STATUS**.

C. Making Cockpit Calls

You can make air-to-ground and air-to-air calls using the ARINC 781 system, the MCDU, and one or two 4-wire headsets. You can manually dial calls or dial previously saved telephone numbers from the MCDU's telephone directory.

(1) Making Calls from the Telephone Directory

You can make voice calls from the numbers you have saved in the MCDU's telephone directory. Numbers can be saved in the telephone directory using the MCDU or the ORT.

To make a call from the telephone directory:

1. On the SAT-PHONE 1/2 page, press the key next to **DIRECTORY**.
The SAT DIRECTORY INDEX page appears.

**SYSTEM DESCRIPTION, INSTALLATION, AND MAINTENANCE MANUAL
ARINC 781 SDU, SCM, and FMPA**

	1	5	10	15	20	24																				
	1	S	A	T	D	I	R	E	C	T	O	R	I	E	I	N	D	E	X	1	/	2				
1L	3	<	E	M	E	R	G	E	N	C	Y					C	O	M	P	A	N	Y	>	1R		
2L	5	<	A	T	L	A	T	S							O	P	E	R	A	T	I	O	N	S	>	2R
3L	7	<	P	A	C	A	T	S							-	-	-	-	-	-	-	-	-	-	>	3R
4L	9	<	I	N	D	A	T	S							-	-	-	-	-	-	-	-	-	-	>	4R
5L	11	<	-	-	-	-	-	-	-	-	-	-	-	-	-	-	-	-	-	-	-	-	-	-	>	5R
6L	13	<	R	E	T	U	R	N																		6R

- To access phone numbers in a directory, press the key next to a directory name.
The SAT DIRECTORY page appears.

NOTE: If an entry has the < symbol in the SAT-L column, that entry can be dialed on Classic Aero channels. If an entry has the > symbol in the SAT-R column, that entry can be dialed on SBB channels. If there is no symbol, the entry cannot be dialed on that channel. For example, in the SAT DIRECTORY shown below, NANDI CTR cannot be dialed on the SBB channel because it's priority is higher than PUB (public).

	1	5	10	15	20	24																				
	1		S	A	T	D	I	R	E	C	T <td>O</td> <td>R</td> <td>I</td> <td>E</td> <td></td> <td></td> <td></td> <td>K</td> <td>K</td> <td>/</td> <td>2</td> <td>0</td>	O	R	I	E				K	K	/	2	0			
		S	A	T	-	L				P	A	C	A	T	S				S	A	T	-	R			
1L	3	<	-	-	-	A	U	C	K	L	A	N	D	C	R	T									>	1R
							3	5	6	7	8	3														
2L	5	<	-	-	-	N	A	N	D	I	C	T	R													2R
							7	6	5	8	7	2														
3L	7	<	-	-	-	O	A	K	L	A	N	D	C	T	R											3R
							3	6	5	7	9	3														
4L	9	<	-	-	-	-	-	-	-	-	-	-	-	-	-	-	-	-	-	-	-	-	-	-	>	4R
5L	11	<	-	-	-	-	-	-	-	-	-	-	-	-	-	-	-	-	-	-	-	-	-	-	>	5R
6L	13	<	R	E	T	U	R	N																		6R

- Press the key to the left or right of the number you wish to dial. Pressing the left key loads the number on SAT-L and pressing the right key loads the number on SAT-R.

The MCDU returns to the SAT-PHONE 1/2 page and the number is displayed under the selected channel (SAT-L or SAT-R).

**SYSTEM DESCRIPTION, INSTALLATION, AND MAINTENANCE MANUAL
ARINC 781 SDU, SCM, and FMPA**

4. Optionally, to change the priority of the call, press the key next to **PRI**. Valid values are PUB (public), LOW (low), HGH (high), and EMG (emergency).

NOTE: You cannot change the priority of calls on SAT-R (SBB) channels. SBB calls are always public priority.

5. Press the key next to **MAKE CALL**.

The call status is shown on the SAT-PHONE 1/2 page.

(2) Ending Calls

To end a call:

- On the SAT-PHONE 1/2 page, press the key next to **END CALL**.

When a call is ended, the MCDU briefly shows the status of why the call ended. To clear the status, press the key next to **CLR STATUS**.

D. Viewing BITE Information

From the SATCOM BITE menu, you can view BITE information to determine subsystem health.

To view BITE information:

1. On the MCDU main menu, press the key next to **SAT-PHONE**.
2. On the MCDU keyboard, press the **NEXT PAGE** key to advance to the second page of the SAT-PHONE menu, and then press the key next to **SATCOM BITE**.

The SATCOM BITE page appears.

	1		5		10		15		20		24	
	1				S A T C O M		B I T E					1
1L	3	S D U					S Y S		B U S	>	3	1R
		OK							OK			
2L	5	<	S U B S Y		H L T H		S U B S Y		B U S	>	5	2R
		OK							OK			
3L	7	<	O V E R T E M P				C H A N N E L S				7	3R
		OK			1	F A I L	2	OK				
4L	9	<	S C M				R F		P A T H	>	9	4R
		OK							OK			
5L	11						U S I M / D A T A			>	11	5R
							1 / 1		1 / 1			
6L	13	<	R E T U R N								13	6R

You can view the following information from this screen:

- SDU status on the line below **SDU**
- Overall health of all subsystem components (SCM, DLNA, HGA, and FMPA) on the line below **SUBSY HLTH**
- Thermal status of the SDU, HGA, and FMPA on the line below **OVERTEMP**

**SYSTEM DESCRIPTION, INSTALLATION, AND MAINTENANCE MANUAL
ARINC 781 SDU, SCM, and FMPA**

- SCM health on the line below **SCM**
- Peripheral LRU bus status on the line below **SYS BUS**
- Subsystem bus status on the line below **SUBSY BUS**
- The number of functional channels followed by the number of installed channels on the line below **CHANNELS**
- RF path status on the line below **RF PATH**
- USIM and data bus status on the line below **USIM/DATA**

NOTE: Valid values for status are OK and FAIL. If the status of a subsystem is FAIL, press the key next to the subsystem to view the details.

To view more information about the health of a particular subsystem, press the key next to the name of the subsystem. For more information about the various MCDU menu screens, see "Troubleshooting and Fault Isolation" on page 4-8.

Blank Page

INSTALLATION

This section describes the procedures required to install the ARINC 781 system (SDU, SCM, and optionally, FMPA) on an aircraft, including the following sections:

- Advisories
- Pre-Installation Inspection
- Installation Procedure
- Connection Details
- Installation and Engineering Drawings

1. Advisories

Before performing any installation procedures, read the safety advisories listed in the Introduction on page INTRO-4 of this manual.

2. Pre-Installation Inspection

Before installing any ARINC 781 system, conduct a pre-installation inspection of all parts to make sure that no damage occurred during shipping.

A. Unpacking and Inspecting Equipment

- Unpack the ARINC 781 equipment from the shipping containers.
- Verify that the part number displayed on the shipping box and equipment component matches the model and part number ordered. If components are missing from the shipment, contact the supplier immediately and report the problem.
- Visually inspect the ARINC 781 equipment for any shipping damage. If any shipping damage has occurred, contact the shipping carrier immediately and report the problem.
- Check the ARINC 781 equipment connectors for corrosion and damage. If damage is noted, do not apply power to the equipment. Contact the supplier immediately to report the problem.

B. Cabling Notes

Before proceeding with the installation of the ARINC 781 system, read all cabling notes provided on the Interconnection and Contact Assignment drawings on page 3-19.

3. Installation Procedure

Only authorized technical personnel, trained in general aviation workmanship, that have a basic understanding of SATCOM systems should proceed with the following procedure.

Before performing any installation procedures, read the safety advisories listed in “Advisories” on page 8 of this manual.

1. Install the SDU in a 6 MCU tray as per ARINC 600. The minimum clearance between the SDU and any other equipment installed above it shall be no less than 0.5 inches.
2. Install the SCM in any orientation. Refer to Table 1-2 on page 1-5 for the SCM mounting specification.
 - There are no clearance requirements for the SCM.
 - The SCM must be thermally insulated from the structure on which the SCM is mounted. The SCM includes heaters to maintain the SIM cards at an appropriate temperature. A large structure can act as a heat sink and reduce the effectivity of the SCM heaters.
3. If using an external FMPA, install the FMPA in any orientation. Refer to Table 1-3 on page 1-6 for the FMPA mounting specification. Refer to Figure 3-3 on page 3–11 for required clearances.
4. Connect the SCM to the SDU. The SDU supports one RS-422 interface for interconnect to the SCM.
5. Connect the SDU to the antenna subsystem. The SDU supports ARINC 429 communication to and from the antenna subsystem.
6. Connect the SDU to the MCDU(s). The SDU supports three ARINC 429 receive interfaces and one ARINC 429 transmit interface for interconnect to the flight deck MCDU(s).
7. If using an external FMPA, connect the SDU to the FMPA. The SDU supports one ARINC 429 interface for communication to and from the FMPA.

4. Connection Details

A. SDU

The SDU uses two external interface connectors:

- Rear Connector—a low insertion force, size 2 shell receptacle accommodating coaxial and signal interconnections in the top plug insert, QuadraX and signal connections in the middle plug insert, and coaxial and power interconnections in the bottom plug insert. Pin assignments are compliant with ARINC Characteristic 781 with top plug and middle plug deviations as shown in Table 3-1.
- Front Connector—an RJ45 and 9S DSUB connector providing 10BT Ethernet interfaces and an RS-232 maintenance interface. Pin assignments are shown in Table 3-2. The front connector is behind a maintenance cover. This connector provides access to maintenance and troubleshooting information when the SDU is not in normal operation.

**SYSTEM DESCRIPTION, INSTALLATION, AND MAINTENANCE MANUAL
ARINC 781 SDU, SCM, and FMPA**

Table 3-1 SDU Rear Connector Pin Deviations

Description	Pin	Deviation
Top Plug Insert Pin Deviations		
Router Processor Maintenance TXD	TP01A	ATE pin 1
Router Processor Maintenance RXD	TP01B	ATE pin 2
Router Processor & Data I/O Processor Maintenance GND	TP01C	ATE pin 3
Data I/O Processor Maintenance TXD	TP01D	ATE pin 4
Data I/O Processor Maintenance RXD	TP01E	ATE pin 5
CC1 Processors #1 & #2 Maintenance GND	TP01F	ATE pin 6
CC1 Processor #1 Maintenance TXD	TP01G	ATE pin 7
CC1 Processor #1 Maintenance RXD	TP01H	ATE pin 8
CC1 Processor #2 Maintenance TXD	TP01J	ATE pin 9
CC1 Processor #2 Maintenance RXD	TP01K	ATE pin 10
Download Security	TP02A	ATE pin 11
Voice Processor Maintenance GND	TP02C	ATE pin 13
Voice Processor Maintenance TXD	TP02D	ATE pin 14
Voice Processor Maintenance RXD	TP02E	ATE pin 15
CC2 Processors #1 & #2 Maintenance GND	TP02F	ATE pin 16
CC2 Processor #1 Maintenance TXD	TP02G	ATE pin 17
CC2 Processor #1 Maintenance RXD	TP02H	ATE pin 18
CC2 Processor #2 Maintenance TXD	TP02J	ATE pin 19
CC2 Processor #2 Maintenance RXD	TP02K	ATE pin 20
Middle Plug Insert Pin Deviations		
GPS ARINC 429 Receiver	MP06J/MP06K	Spare
Data Loader Link Enable	MP08E	For Ethernet also

Table 3-2 SDU Front Connector DSUB and RJ45 Pin Assignment

9S DSUB Pin Number	Description	RJ45 Pin Number	Description
1	NC	1	RX+
2	TX	2	RX-
3	RX	3	TX+
4	NC	4	NC
5	GND	5	NC
6	NC	6	TX-

Table 3-2 SDU Front Connector DSUB and RJ45 Pin Assignment (Continued)

9S DSUB Pin Number	Description	RJ45 Pin Number	Description
7	NC	7	NC
8	NC	8	NC
9	NC		

B. SCM

The SCM uses a 15 pin D-type male connector and locking screws. Pin assignments are compliant with ARINC Characteristic 781 and shown in Table 3-3.

Table 3-3 SCM D-Type Connector Pin Assignment

Pin Number	Description
1	Data to SDU A (RS422)
2	Data to SDU B (RS422)
3	Data from SDU A (RS422)
4	Data from SDU B (RS422)
5	Reserved - RS232 Gnd (used for shop loading)
6	Spare
7	Chassis Ground
8	Power Input +8 V to +15 V
9	Reserved - Enable RS232 (used for shop loading)
10	Reserved - 0 V strap output (used for shop loading)
11	Spare
12	Reserved - RS232 Tx (used for shop loading)
13	Reserved - RS232 Rx (used for shop loading)
14	Spare
15	Power Return 0 V

C. FMPA

The FMPA provides three external connectors:

- J1 – Power/Control MIL-C-38999 Series III Insert Arrangement 17-26
- J2 – RF input, TNC female
- J3 – RF output, N Type female

**SYSTEM DESCRIPTION, INSTALLATION, AND MAINTENANCE MANUAL
ARINC 781 SDU, SCM, and FMPA**

These connectors and their pin layouts are compliant with ARINC Characteristic 781. Table 3-4 describes the FMPA connector pin layout.

Table 3-4 FMPA J1 Connector Pin Assignments

Pin Number	Signal	Description
A	HPA BITE A	ARINC 429 from HPA
B	HPA BITE B	ARINC 429 from HPA
C	RS422 RXD A	Serial data to HPA +
D	RS422 RXD B	Serial data to HPA -
E	RS422 TXD A	Serial data from HPA +
F	RS422 TXD B	Serial data from HPA -
G	SPARE	SPARE
H	SPARE	SPARE
J	Chassis Ground	Chassis Ground
K	SPARE	SPARE
L	SPARE	SPARE
M	Discrete BITE #1	Discrete BITE #1 from HPA
N	Discrete BITE #2	Discrete BITE #2 from HPA
P	Antenna Control A	ARINC 429 to HPA
R	Antenna Control B	ARINC 429 to HPA
S	Antenna Control Shield	Shield for ARINC 429
T	HPA BITE Shield	Shield for ARINC 429
U	RS422 Shield	RS422 Shield
V	SPARE	SPARE
W	SPARE	SPARE
X	115VAC Hot	Aircraft AC power
Y	115VAC Return	Aircraft AC power
Z	SPARE	SPARE
a	Discrete BITE #3	Discrete BITE #3 from HPA
b	ATE Pin	Manufacturer specific
c	SPARE	SPARE

5. Installation and Engineering Drawings

This section contains the Outline and Installation diagrams, and Interconnection and Contact Assignment drawings for the SDU, SCM, and FMPA.

All foldout pages are odd-numbered and not-backed for print production purposes.

A. Outline and Installation Drawings

The Outline and Installation drawings on pages 3-7 to 3-17 show the physical characteristics of the SDU, SCM, and FMPA, and provide installation data for the system.

B. System Interconnect Drawings

System Interconnect drawings on pages 3-19 to 3-23 show the interconnection details for the SDU, SCM, and FMPA.

Blank Page

SYSTEM DESCRIPTION, INSTALLATION, AND MAINTENANCE MANUAL
ARINC 781 SDU, SCM, and FMPA

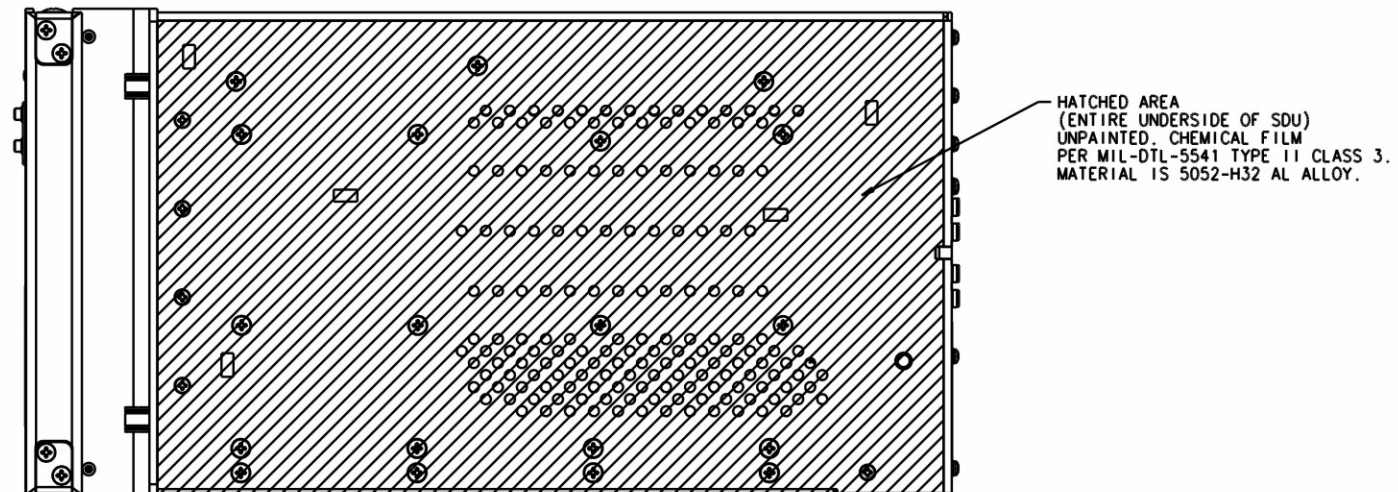
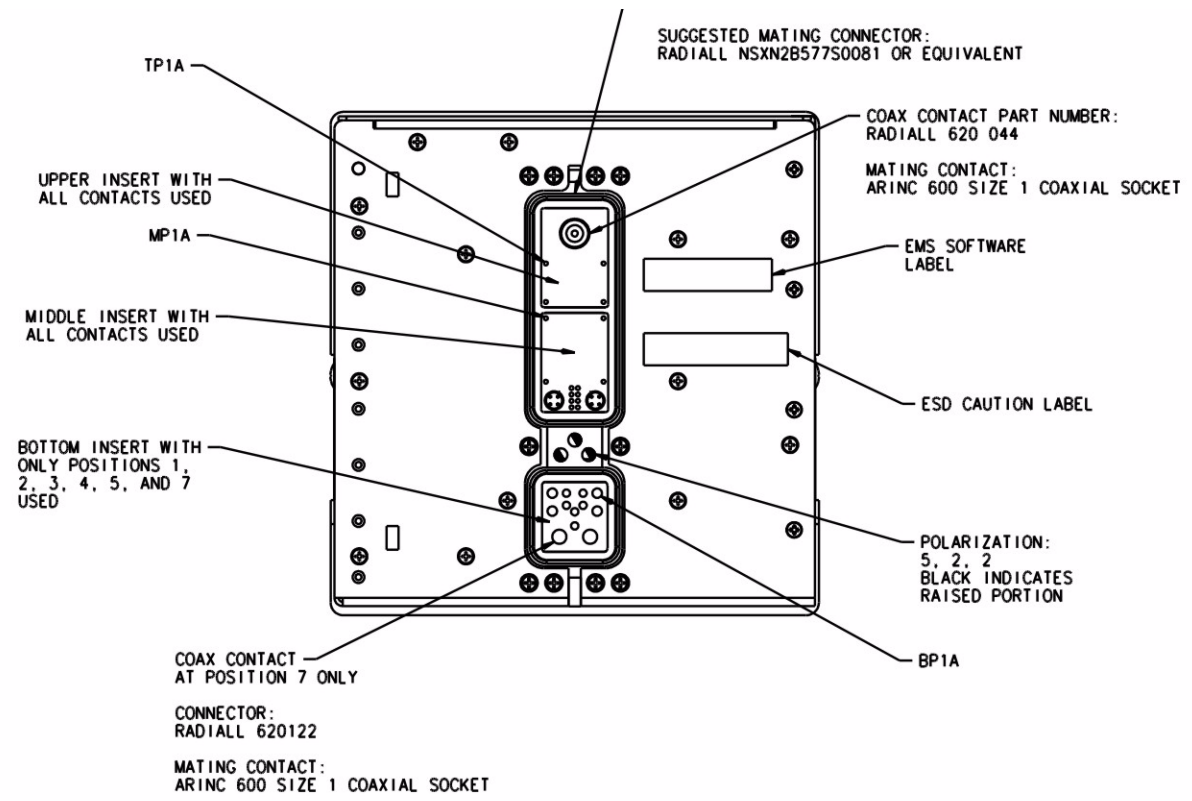
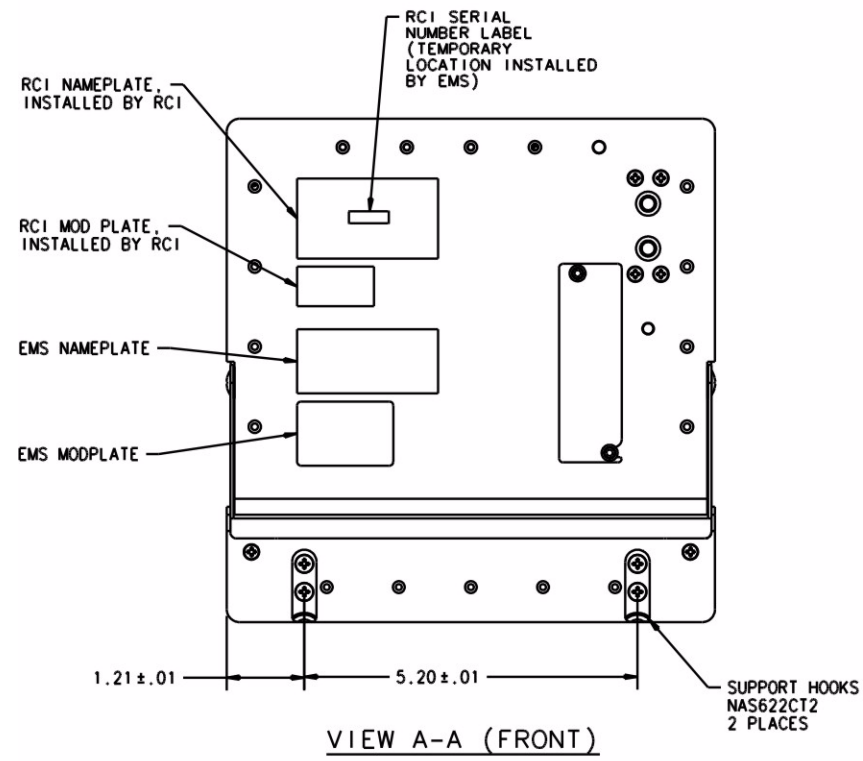

Figure 3-2 ARINC 781 SDU Outline and Installation Drawing, 1394-E-1100 Rev B00 (Sheet 2 of 2)

Doc No 1394-E-1100
REV B
SHEET 2

Blank Page

SYSTEM DESCRIPTION, INSTALLATION, AND MAINTENANCE MANUAL
ARINC 781 SDU, SCM, and FMPA

NOTES:

1. THIS UNIT MEETS THE DIMENSIONAL REQUIREMENTS OF ARINC SPECIFICATION 781.

2. MAXIMUM WEIGHT IS 6.8KG (15.0 lbs).

3.  INDICATES APPROXIMATE CENTER OF GRAVITY.

4. COOLING AIR REQUIREMENT PER ARINC 781:

-SUPPLY AT AIR INLET: 72kg/hr OF 60°C (MAX)
-PRESSURE DROP: 51 +/- 5 mm OF WATER

5. FINISH:

-METAL TREATMENT: CHEMICAL FILM PER MIL-DTL-5541 TYPE 11, CLASS 3
-EXTERIOR FINISH: PRISM POWDER COAT PB134LT (POLYESTER POWDER, SATIN SANTEX BLACK)

6. ENVIRONMENTAL CHARACTERISTICS:

-RTCA DO-160E: [(A2)(F2)Z]BAB[S(CLMY) R(C1)]EXXXFXZ[A(WF)H]AK(WF)[(CW)][RR]M[A3J33]XXAX

7. LABEL CONTENT: TBD AS PER ECM EMS-RC1-005-2007-11-30

8. MAXIMUM POWER DISSIPATION: 175 WATTS

9.  AIR CONNECTION TUBE END PER AS5131 STYLE B (AS5131B32)

10.  FRONT PANEL THICKNESS IS 0.064"

11.  SEE VIEW B & D ON SHEET 2 FOR ADJACENT EQUIPMENT STAY OUT ZONE

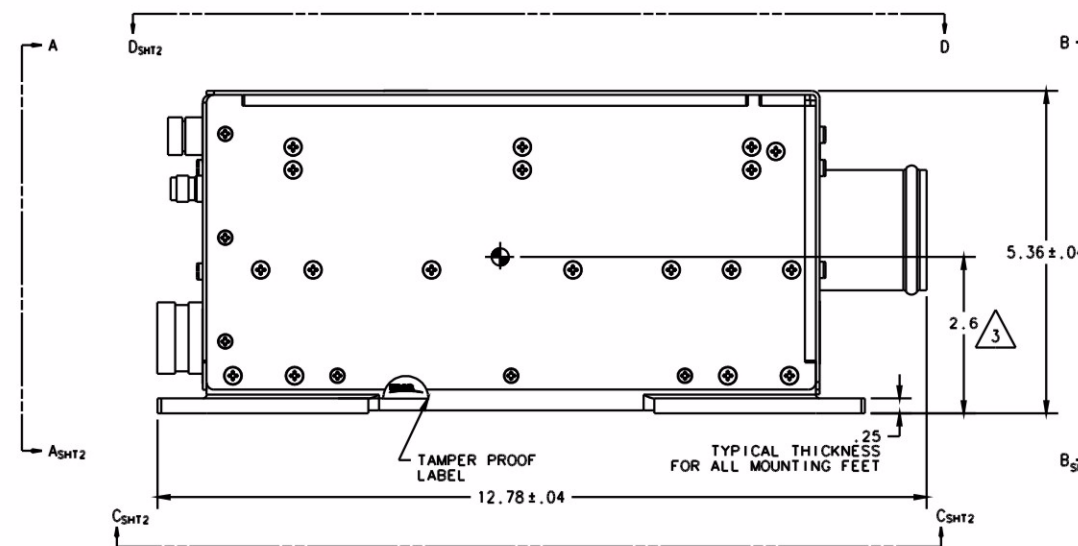
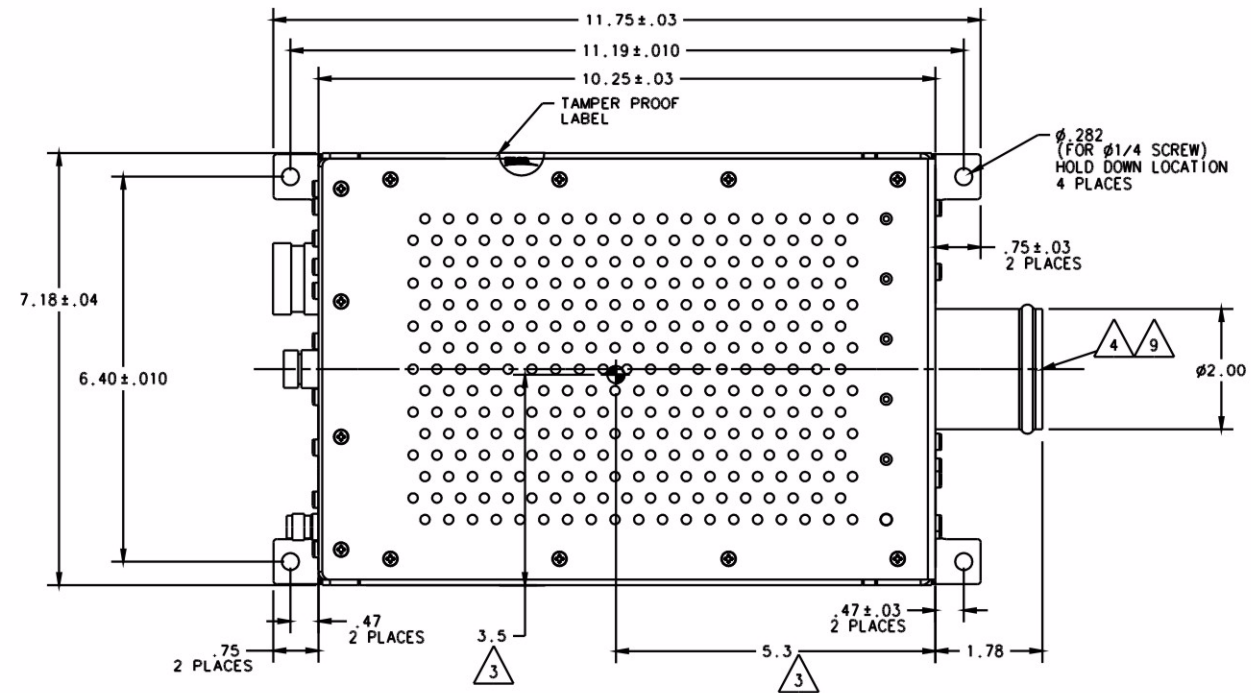
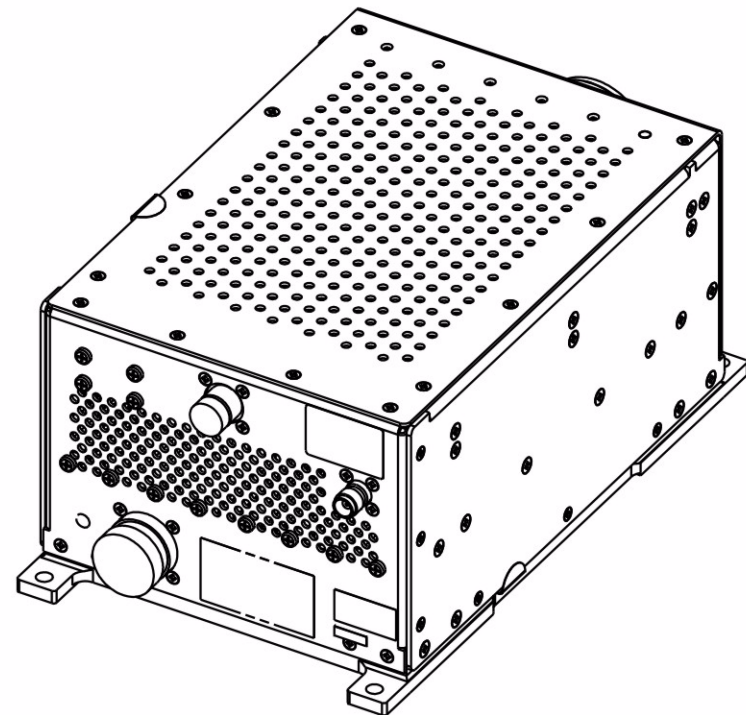

DES No 1394-E-1200
 REV D
 SH1

Figure 3-3 ARINC 781 FMPA Outline and Installation Drawing, 1394-E-1200 Rev D00 (Sheet 1 of 2)

Blank Page

SYSTEM DESCRIPTION, INSTALLATION, AND MAINTENANCE MANUAL
ARINC 781 SDU, SCM, and FMPA

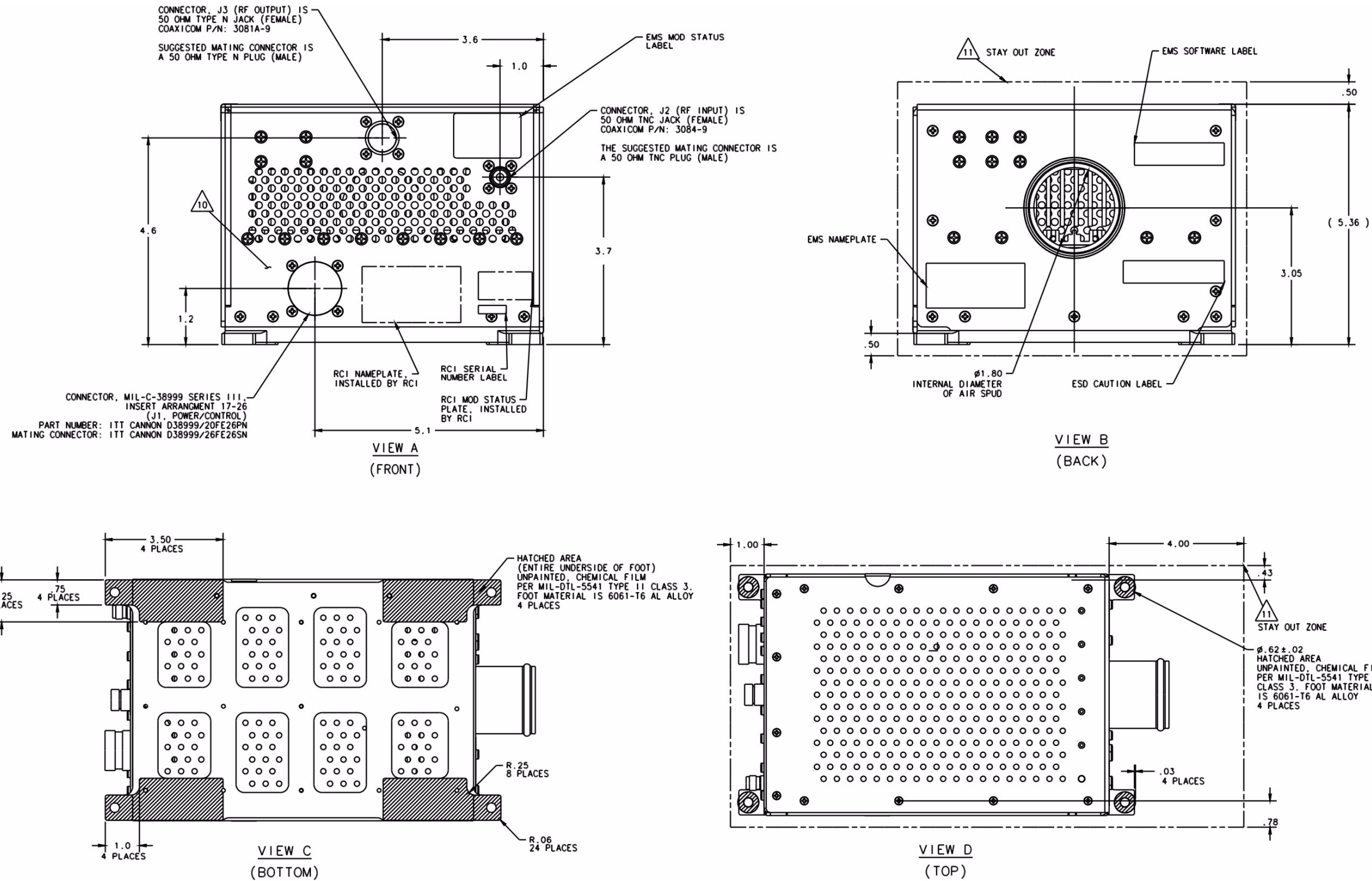



FIG. NO. 1394-E-1200
REV. D
SHEET 2

Figure 3-4 ARINC 781 FMPA Outline and Installation Drawing, 1394-E-1200 Rev D00 (Sheet 2 of 2)

Blank Page

**SYSTEM DESCRIPTION, INSTALLATION, AND MAINTENANCE MANUAL
ARINC 781 SDU, SCM, and FMPA**

NOTES:

1. THIS UNIT MEETS THE DIMENSIONAL REQUIREMENTS OF ARINC SPECIFICATION 781
2. MAXIMUM WEIGHT IS .45 kg (1 LB)
3.  INDICATES APPROXIMATE CENTER OF GRAVITY
4. FINISH:
-METAL TREATMENT: CHEMICAL FILM PER MIL-DTL-5541 TYPE 11, CLASS 3
-EXTERIOR FINISH: PRISM POWDER COAT PB134LT (POLYESTER POWDER, SATIN SANTEX BLACK)
5. ENVIRONMENTAL CHARACTERISTICS:
-RTCA DO-160E: [(A2)(F2)Z]BAB[S(BLMY) R(B1)]EXXXFXZ
[AA(WF)H]A[ARK(WF)][(CW)(CC)][RR]M[A3J33]XXAX
6. LABEL CONTENT: AS PER ECM EMS-RCI-005-2007-11-30

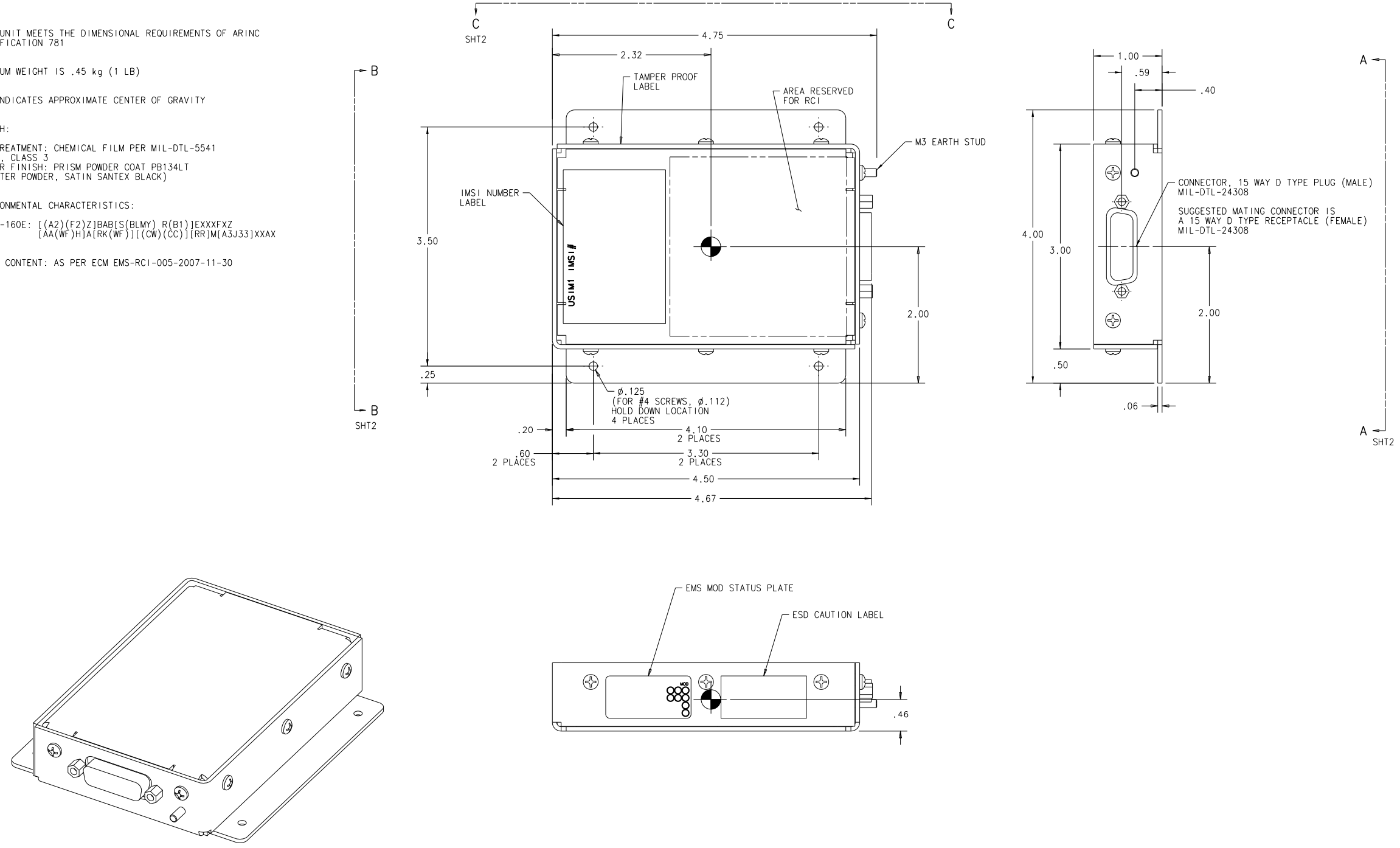
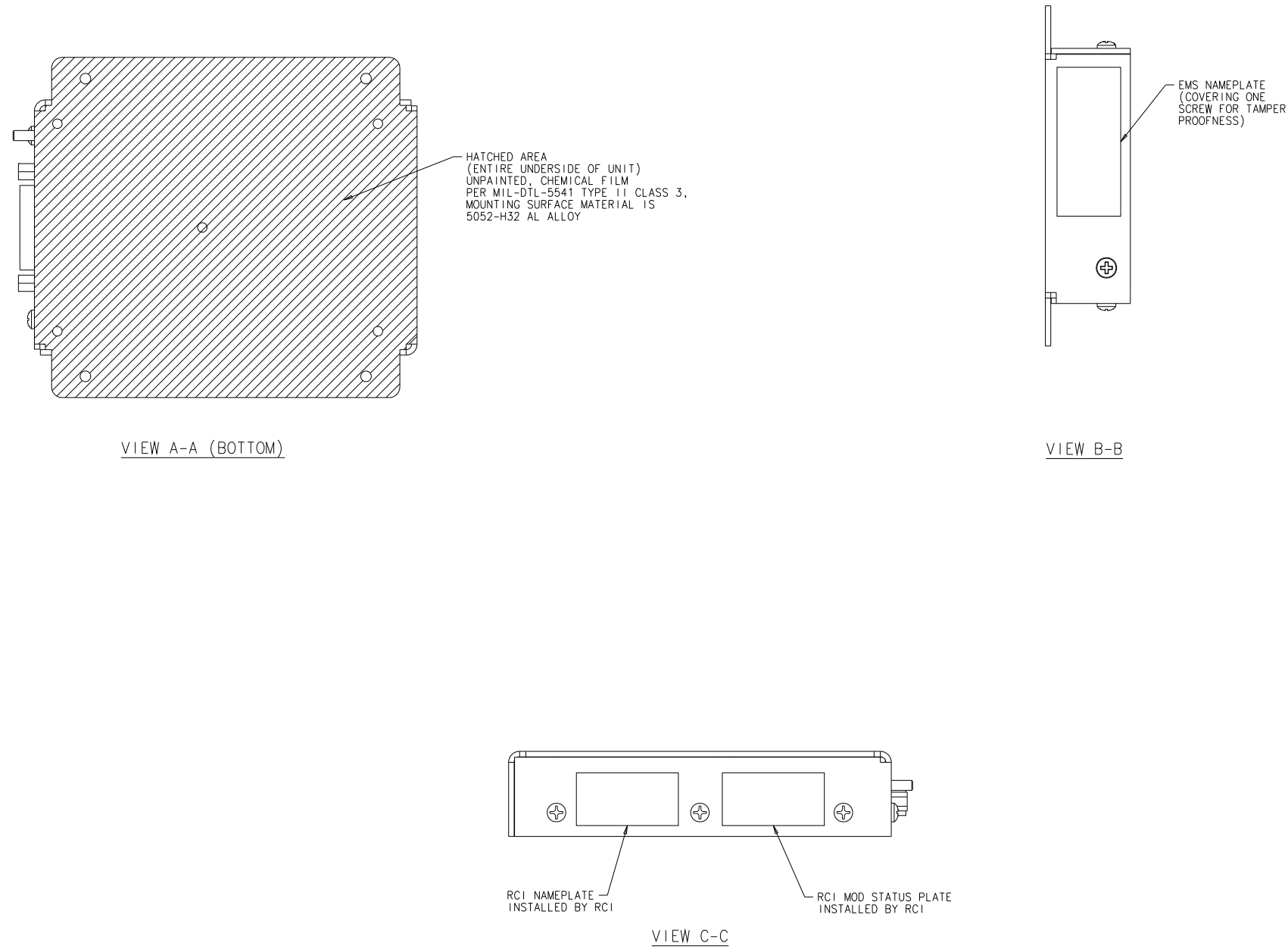

Figure 3-5 ARINC 781 SCM Outline and Installation Drawing, 1394-E-1300 Rev B00 (Sheet 1 of 2)

Dwg No 1394-E-1300
 Rev B SHT 1

Blank Page

**SYSTEM DESCRIPTION, INSTALLATION, AND MAINTENANCE MANUAL
ARINC 781 SDU, SCM, and FMFA**



Dwg No 1394-A-E-1300
 Rev B
 SMT 2

Figure 3-6 ARINC 781 SCM Outline and Installation Drawing, 1394-E-1300 Rev B00 (Sheet 2 of 2)

Blank Page

SYSTEM DESCRIPTION, INSTALLATION, AND MAINTENANCE MANUAL
ARINC 781 SDU, SCM, and FMPA

NOTES:

1. MAX LOSS: 2.5dB TO ANTENNA.
2. LOSS: 6-25dB.
3. LOSS: 8-18dB.
4. DISTANCE BETWEEN SDU AND SCM TO BE LESS THAN 10 METERS. WIRE USED TO ROUTE SCM POWER (SCM PWR) MUST BE 22 AWG MINIMUM.
5. SEE SHEET 2 FOR INTERCONNECTION DIAGRAM.
6. IF THE NUMBER OF OTHER CONFIGURATION PINS IS EVEN, THEN STRAP CONFIGURATION PIN 3 (TP3F) TO SERVICE AVAILABILITY DISCRETE 1 (MP11E).

DOC No
1394-B-1001
REV
A
SHT
1

Figure 3-7 ARINC 781 System Interconnect Drawing, 1394-B-1001 Rev A00 (Sheet 1 of 3)

Blank Page

SYSTEM DESCRIPTION, INSTALLATION, AND MAINTENANCE MANUAL
ARINC 781 SDU, SCM, and FMPA

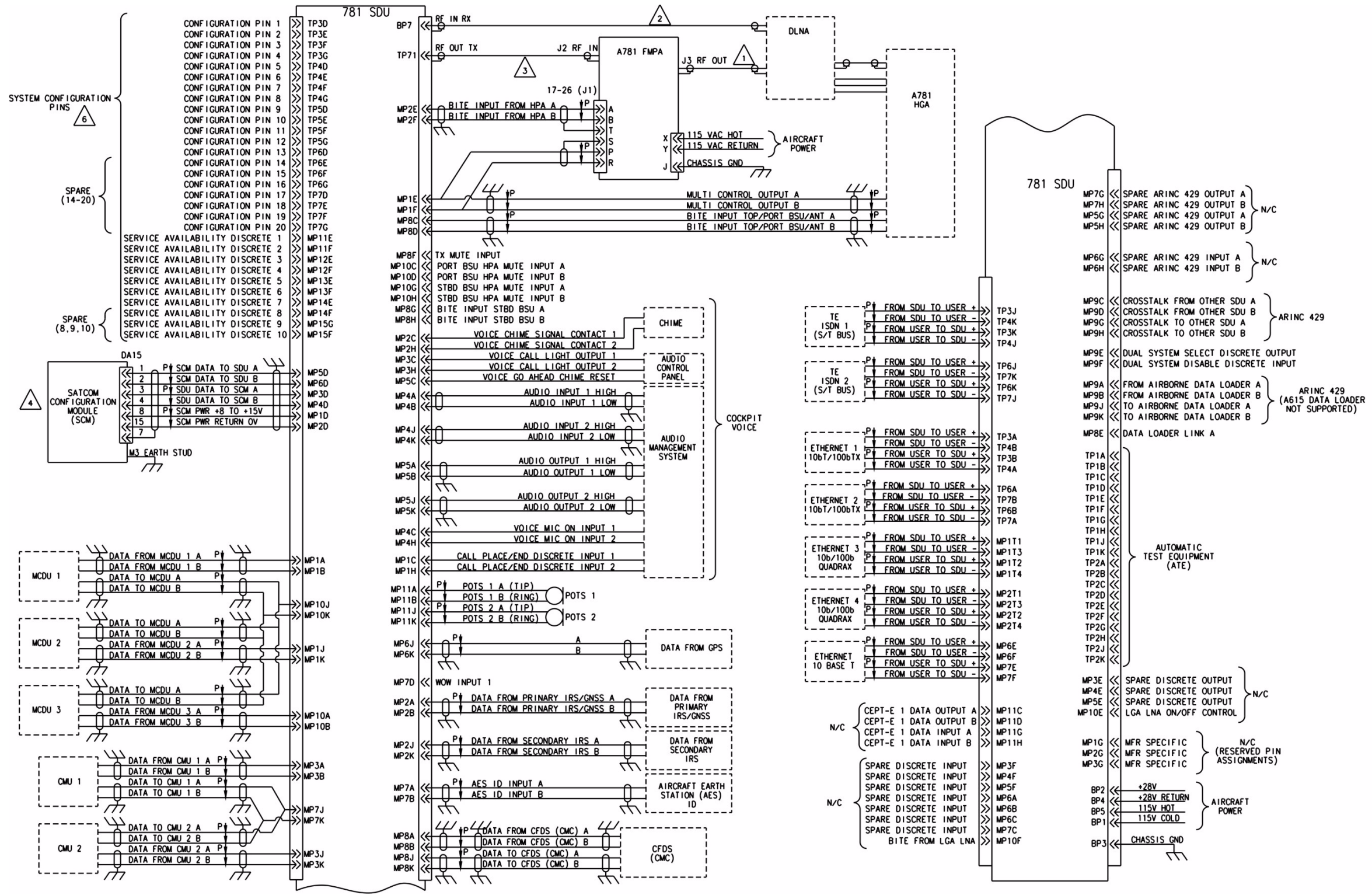
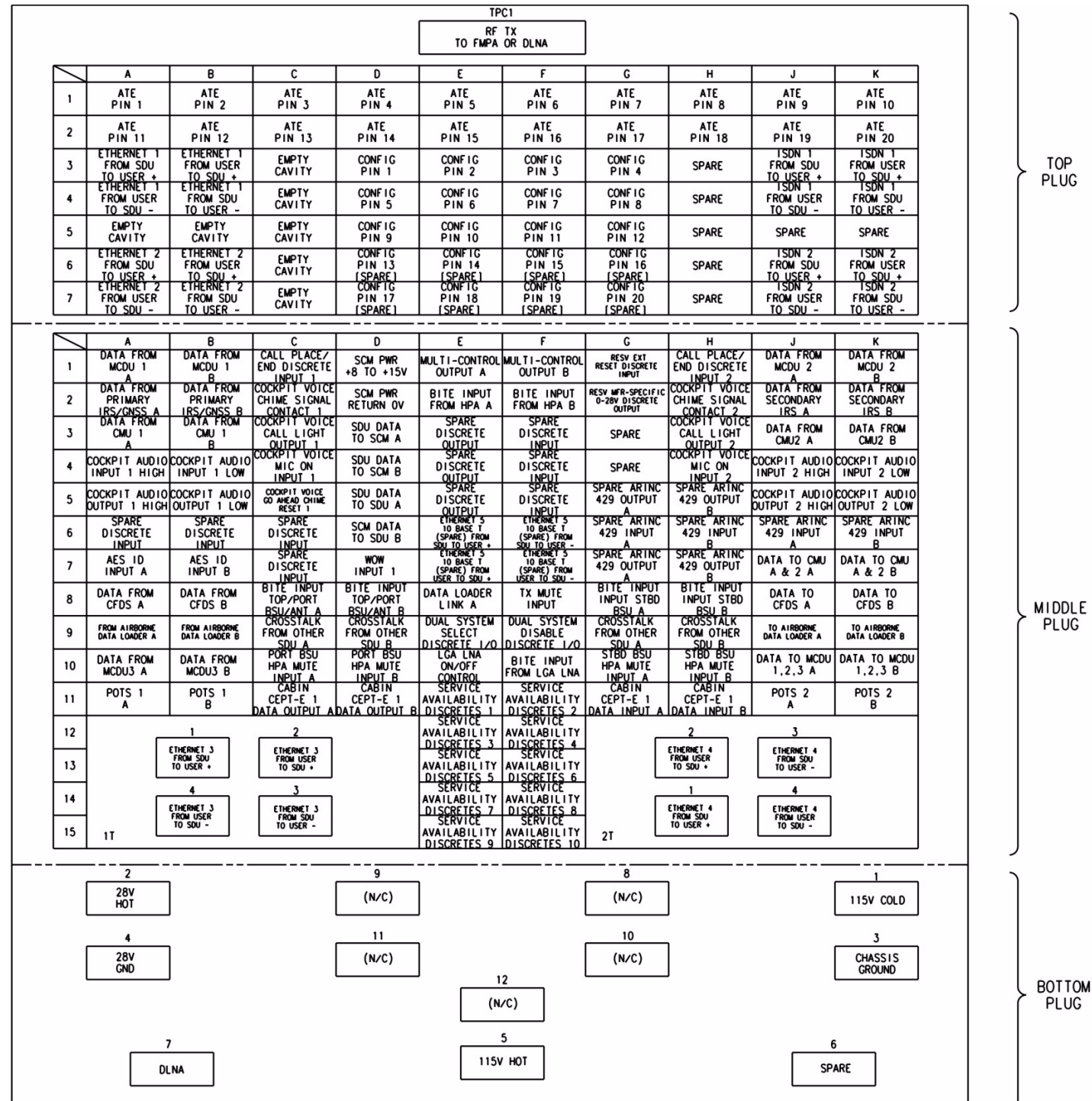

Figure 3-8 ARINC 781 System Interconnect Drawing, 1394-B-1001 Rev A00 (Sheet 2 of 3)

Blank Page

SYSTEM DESCRIPTION, INSTALLATION, AND MAINTENANCE MANUAL
ARINC 781 SDU, SCM, and FMPA



CONTACT ASSIGNMENTS FOR J1 OF ARINC 781 SDU
VIEW SHOWN ON MATING FACE

Figure 3-9 ARINC 781 System Interconnect Drawing, 1394-B-1001 Rev A00 (Sheet 3 of 3)

Doc No 1394-B-1001 Rev A Sm 2

Blank Page

TEST AND FAULT ISOLATION

This section provides test procedures to determine the operational readiness of SDU units.

There are no operational test procedures defined for the SCM or FMPA. SCM and FMPA health are determined by accessing the SDU BITE information.

If the ARINC 781 equipment passes all tests in this section but does not function according to the installation requirements, the fault may be with equipment or wiring outside the ARINC 781 system.

This section includes:

- Operational and Diagnostic Testing
- Troubleshooting and Fault Isolation
- Adjustment/Alignment Procedures
- Modification History

NOTE: Depending on the version of software installed, the MPU report and menu screens displayed may differ from those shown as examples in this manual.

1. Operational and Diagnostic Testing

This section includes the following sections:

- General
- Test and Fault Isolation Equipment Requirements
- Operational and Diagnostic Test Procedures

A. General

Usually, the ARINC 781 system requires testing for one of the following reasons:

- To verify the operational readiness of the system during and after installation on an aircraft
- To verify that a fault exists and produce system reports for troubleshooting purposes
- To verify the operational readiness of repaired LRUs during re-installation on an aircraft

This section includes test and fault isolation procedures for the ARINC 781 system. All test and load procedures require the ARINC 781 SDU MPU, which is accessed by connecting to the maintenance port of the SDU.

B. Test and Fault Isolation Equipment Requirements

Table 4-1 lists the equipment required to access the SDU MPU and perform operational and diagnostic testing on the SDU.

**SYSTEM DESCRIPTION, INSTALLATION, AND MAINTENANCE MANUAL
ARINC 781 SDU, SCM, and FMPA**

Table 4-1 List of Required Test Equipment

Item	Equipment	Specification	Quantity
Computer	Standard	VT-100 386 CPU, 20 MHz or higher	1
VT-100 terminal emulation program	HyperTerminal®, ProComm Plus®, or equivalent	Serial communication program using an RS-232 port	1
Cable	RS-232 cable	Maximum length 25 feet	1

C. SDU MPU

This section describes the SDU MPU and provides the connection and cabling details required to access and use the program.

(1) Connecting to the MPU

The MPU provides a system interface for fault isolation and diagnostic procedures.

To use the SDU MPU, connect an RS-232, VT-100 terminal (computer operating a terminal emulation program) to the RS-232 maintenance port interface of the SDU.

The maintenance port on the front panel of the SDU provides a direct connection to the MPU using a DB9 connector.

Figure 4-1 provides cabling details for the SDU maintenance port.

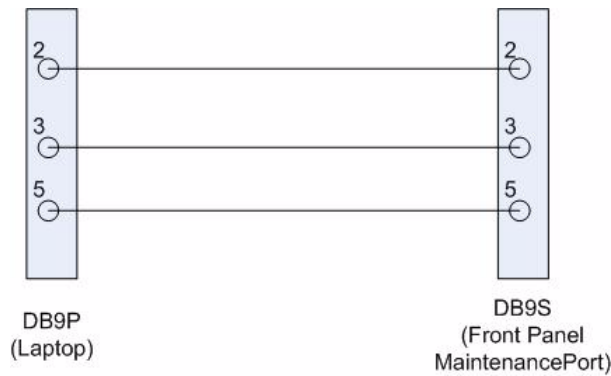

Figure 4-1 Maintenance Cable

(a) Interface Requirements

A standard VT-100 compatible terminal running an emulator program (such as HyperTerminal, ProComm Plus, or similar) provides the user interface to the SDU MPU. The RS-232 terminal connection settings for SDU maintenance ports are listed in Table 4-2.

Table 4-2 Maintenance Port Connection Settings

Parameter	Setting
Character Format	ASCII
Baud Rate	19200 bps
No. of bits	8
Parity	None
Stop bits	1
Flow Control	None

(2) Using the SDU MPU

This section describes the basic procedures for using and navigating the SDU MPU.

NOTE: There are various levels of access to the MPU. Each level is protected by a different password. This section describes the MPU functions available using the Level 1 password.

(a) Entering Passwords

You can enter the password any time after the SDU boots.

- To access Level 1 functions, type **menu**.

NOTE: The password does not appear on the screen when you type it.

(b) Navigating the SDU MPU

- To scroll through the available menus, press CTRL+N.
- To go to the previous menu, press CTRL+O.
- To refresh the menu screen or exit from a Reports Menu, press ESC.

(c) Selecting Menu Items

- To enable test or data entry functions, press the letter associated with the menu items.

(d) Selecting Reports

The reports available through the MPU enable users to view information about the configuration and status of the SDY. This information is used to troubleshoot the communication system on the aircraft.

To access reports:

1. In the MPU, press EQUAL SIGN (=).

A list of reports appears. Active reports show as toggled on. Inactive reports show as toggled off.

2. To activate a report, type the report number, and then press ENTER.

NOTE: Multiple reports can be activated at the same time; type and enter each report number separately.

3. To turn off individual, active reports, type the report number you want to toggle off, and then press ENTER.

**SYSTEM DESCRIPTION, INSTALLATION, AND MAINTENANCE MANUAL
ARINC 781 SDU, SCM, and FMPA**

4. To turn off all active reports, press EQUAL SIGN (=), and then press X.

(3) Menu Item Descriptions

This section provides a brief description of the Level 1, MPU menu items used for test and fault isolation procedures.

In active SDUs, menu screens display the firmware version.

NOTE: Depending on the version of software installed and the system configuration, the menu and reports available to users may differ slightly from the illustrations shown and described in this document.

(a) Menu 1

Figure 4-2 shows an example Menu 1 screen display. Table 4-3 describes the items available in Menu 1.

MENU 1		FIRMWARE Vx.x GND	
Y	explain error status	U	list event log (hex)
F	print equipment stats		
<CTRL> N	next menu	<CTRL> O	previous menu = select reports

Figure 4-2 Menu 1 Screen Display

Table 4-3 Menu 1 Item Descriptions

Menu Item	Description
Y: explain error status	Reports error status when failure LED is illuminated. Displays OK if no error exists.
F: print equipment stats	Prints a list of the current equipment statistics, including temperature, number of power-ups, hours of operation, time since power-up, and processor usage.
U: list event log	Lists the current event log (hex format).

(b) Menu 2

Figure 4-3 shows an example MPU Menu 2 screen display. Table 4-4 describes the items available in Menu 2.

**SYSTEM DESCRIPTION, INSTALLATION, AND MAINTENANCE MANUAL
ARINC 781 SDU, SCM, and FMPA**

MENU 2	FIRMWARE Vx.x GND
L re-enter logon password	V get firmware versions
Z reset A781 SDU	C query loss of cooling mode
H query SDU-FMPA cable loss	
<CTRL> N next menu	<CTRL> O previous menu = select reports

Figure 4-3 Menu 2 Screen Display

Table 4-4 Menu 2 Item Descriptions

Menu Item	Description
L: re-enter logon password	Permits a user to enter a new access level password.
Z: reset A781 SDU	Enables a complete, soft reset of the SDU; once reset, the menu access password must be re-entered.
H: query SDU-FMPA cable loss	Initiates the cable loss determined in auto-calibration.
V: get firmware versions	Displays the kernel and application software versions for the Control Processor, Data I/O Processor, Channel Cards
C: query loss of cooling mode	Indicates if loss of cooling mode is active or inactive.

(c) Menu 3

Figure 4-4 shows the menu 3 screen display. Table 4-5 describes the items available in Menu 3.

MENU 3	FIRMWARE Vx.x
F list call log	G clear call log
O list DIO ORT	H list SCM/CP ORT
Y verify CP ORT	
<CTRL> N next menu	<CTRL> O previous menu = select reports

Figure 4-4 Menu 3 Screen Display

Table 4-5 Menu 3 Item Descriptions

Menu Item	Description
F: list call log	Lists Classic call logs for the following events: <ul style="list-style-type: none"> • Successful Aero Log-on • Air-to-ground calls accepted by the SDU • Ground-to-air calls accepted by the SDU Lists SBB call logs for the following events: <ul style="list-style-type: none"> • Attachment or modification of attachment, including change of beam ID • Creation or deletion of primary or secondary contexts
O: list DIO ORT	Lists of ORT items destined for the Data Processor in human readable form.
Y: verify CP ORT	Verifies if file name of the internal copies of the Secure and User ORT are valid or corrupted.
G: clear call log	Clears the call log after a confirmation.
H: list SCM/CP ORT	Lists ORT settings and how they were configured (either by default or through the maintenance port, or via SCM ORT files). "Set by maintenance port" indicates that the ORT parameter is set by the maintenance port.

D. Operational and Diagnostic Test Procedures

You can perform all test procedures presented in this section to test the total operational status of the ARINC 781 system. You can conduct these operational tests for all equipment returned to service after repair.

The procedures assume that the technical personnel are familiar with the test equipment used and can operate the equipment to produce the required inputs and obtain the required results (indications). Refer to the detailed operating procedures and descriptions of the SDU MPU included in this section.

CAUTION: ONLY AUTHORIZED TECHNICAL PERSONNEL WHO ARE TRAINED IN GENERAL AVIATION WORKMANSHIP AND HAVE A BASIC UNDERSTANDING OF SATCOM SYSTEMS SHOULD PERFORM THE OPERATIONAL AND DIAGNOSTIC TEST PROCEDURES IN THIS MANUAL.

CAUTION: CHANGES TO DEFAULT VALUES FOR SOME MENU FUNCTIONS MAY SERIOUSLY DEGRADE SYSTEM OPERATION.

NOTE: This manual describes the basic MPU functions, menus, and reports required for the testing and fault isolation procedures presented in this section. Please consult Product Support before entering any unfamiliar menu selections not described in this manual.

NOTE: Using a terminal emulation program, open a log file and save all test results for future reference and test records.

**SYSTEM DESCRIPTION, INSTALLATION, AND MAINTENANCE MANUAL
ARINC 781 SDU, SCM, and FMPA**

Refer to the Outline and Installation diagrams (Figure 3-1 to Figure 3-6) and the Interconnection and Contact Assignment drawings (Figure 3-7 to Figure 3-9) for additional information.

(1) Test Setup Procedure

The test setup procedure is presented in Table 4-6.

Table 4-6 Test Setup Procedure

Step	Action
1.0	Make sure that the SDU is powered down and disconnected from the power source.
2.0	Remove the maintenance-port connector cover.
3.0	Connect a maintenance cable to the SDU front-panel maintenance port connector.
4.0	Connect the other end of the cable to the serial port of the computer.
5.0	Open a log file to capture all test data.

(2) Post Test

When testing is completed, follow the steps in Table 4-7.

Table 4-7 Post Test Procedure

Step	Action
1.0	Save the log file of the test results (or data) for future reference.
2.0	Remove power from the SDU that was tested and from all other test equipment.
3.0	Disconnect test equipment from the SDU.
4.0	Replace the maintenance-port connector cover (if it was removed during the test setup).

If the Unit Under Test (UUT) **PASSED** the test, re-install the unit on the aircraft.

If the UUT **FAILED** the test, return the UUT along with a hardcopy printout of the recorded (captured) log file of the test results to the manufacturer for service and repair. Indicate the date of the test and the serial number of the UUT on the test documentation.

(3) Installation and Operational Verification Tests

To verify that the ARINC 781 system is ready for operation, use the following procedures:

- Power-On Test
- BITE

(a) Power-On Test

To complete the power-on test, follow the steps in Table 4-7.

Table 4-8 Power-On Test Procedure

Step	Action
1.0	Follow the test setup procedure in Table 4-6 on page 4-7.
2.0	Power-on the SDU.
3.0	Power-on the FMPA (if applicable).
4.0	Check the status of the front panel LEDs. Verify that the green LED flashes for 60 seconds and then turns off. Verify that the red LED is not illuminated. For more information about the LED signals, refer to "LEDs" on page 1-11.
5.0	Review the BITE status of all system components using the MCDU. Verify that all subsystems show OK status. For more information about using the MCDU, refer to "Viewing BITE Information" on page 2-8.
6.0	Follow the post test procedure in Table 4-7 on page 4-7.

(b) BITE

If equipment connected to the ARINC 781 avionics system provides wrong information or does not provide a signal to the ARINC 781 SDU, the SDU cannot function properly. You can check the status of connected equipment with the MCDU BITE screens. To check the status of connected equipment, follow the procedure described in "Viewing BITE Information" on page 2-8.

The SATCOM BITE page provides information about the results from BITE for various parts of the ARINC 781 system.

- If BITE fails a component, remove the component from service and return it to the equipment supplier—see "Maintenance and Repair" on page 5-1.
- If BITE fails a component other than the ARINC 781 SDU, FMPA, or SCM, verify the operation of that component and test the satellite communication system again.

2. Troubleshooting and Fault Isolation

This section provides troubleshooting procedures for ARINC 781 systems.

Troubleshooting procedures require data obtained using the MCDU. For specific instructions on how to access and use the MCDU, refer to "Operating the MCDU" on page 2-1.

NOTE: All of the MCDU pages discussed in this section are accessed from the SATCOM BITE page.

A. Subsystem Health

The SATCOM SUBSY HLTH page provides the BITE status of subsystem components.

To check the subsystem health, on the SATCOM BITE page, press the key next to **SUBSY HLTH**.

Figure 4-5 illustrates the SATCOM SUBSY HLTH page.

**SYSTEM DESCRIPTION, INSTALLATION, AND MAINTENANCE MANUAL
ARINC 781 SDU, SCM, and FMPA**

	1		5		10		15		20		24								
	1		S	A	T	C	O	M	S	U	B	S	Y	H	L	T	H		1
			L	N	A														
1L	3		O	K														3	1R
			A	N	T														
2L	5		O	K														5	2R
3L	7																	7	3R
			F	M	P	A													
4L	9		O	K														9	4R
			C	O	N	F	I	G	P	A	R	I	T	Y					
5L	11		O	K														11	5R
6L	13	<	R	E	T	U	R	N										13	6R

Figure 4-5 SATCOM Subsystem Health Menu

Table 4-9 describes the information available on the SATCOM SUBSY HLTH menu.

Table 4-9 SATCOM Subsystem Health Menu

Label	Description	Action
LNA	Reports the status of the LNA as OK, NO DATA (if golden label 350 from the antenna is missing or HGA is disconnected), TEST, or FAULT. The LNA status matches the HDA status.	If the status is NO DATA, check the bus connections from the Antenna and check the speed of bus. If the status is FAULT, test or troubleshoot the LNA equipment.
ANT	Reports the status of the HGA as OK, FAULT, TEST, or NO DATA.	If the status is FAULT, test or troubleshoot the HGA equipment. If the status is NO DATA check the ARINC 429 bus from the Antenna.
FMPA	Reports the status of the FMPA as OK, FAULT, NO DATA, or NONE. If there is no FMPA configured, the reported status is NONE.	If the status is FAULT, return the FMPA to the equipment supplier. If the status is NO DATA check the cable to the FMPA.
CONFIG PARITY	Reports the status of the rear connector configuration parity as OK (parity is odd) or FAULT (parity is not odd). This status can be different from the setting of Bit 25 in Label 350 to the CMC, which is also set if the secure ORT is missing or invalid.	If the status is FAULT, check strapping—a non-supported configuration may be strapped.

B. SATCOM System Bus

The SATCOM SYSTEM BUS page provides information about the bus status of equipment outside the ARINC 781 system. SATCOM services are not available if the equipment does not operate or communicate properly.

To check the bus status, on the SATCOM BITE page, press the key next to **SYS BUS**.

Figure 4-6 illustrates the SATCOM System Bus page.

	1		5		10		15		20		24
	1				S A T C O M		S Y S		B U S		1
		C F D S							I N A C T I V E		
1L	3	M C D U # 1							O K		3 1R
		M C D U # 2							O K		
2L	5	M C D U # 3							O K		5 2R
		I R S - P R I							O K		
3L	7	I R S - S E C							O K		7 3R
		C M U # 1							O K		
4L	9	C M U # 2							O K		9 4R
		G N S S							O K		
5L	11	A E S I D							N O N E		11 5R
		C T U							O K		
6L	13	< R E T U R N									13 6R

Figure 4-6 SATCOM System Bus Menu

Table 4-10 describes the information available on the SATCOM SYS BUS menu.

Table 4-10 Bus Status Indicators

Bus	Status			
	INACTIVE	NO DATA	NONE	OK
CFDS	No labels of correct speed on bus.	The expected Golden label (227) is not present.	The bus is not installed.	The expected Golden label is present and the bus is active at the correct speed.
MCDU	No labels of correct speed on bus.	The expected Golden label (377) is not present.	The bus is not installed.	The expected Golden label is present and the bus is active at the correct speed.

Table 4-10 Bus Status Indicators

Bus	Status			
	INACTIVE	NO DATA	NONE	OK
IRS - PRI	No labels of correct speed on bus.	The expected Golden label (310) is not present.	N/A	The expected Golden label is present and the bus is active at the correct speed.
IRS - SEC	No labels of correct speed on bus.	The expected Golden label (310) is not present.	The IRS2Type secure ORT parameter specifies whether it is connected or not connected.	The expected Golden label is present and the bus is active at the correct speed.
GNSS	No labels of correct speed on bus.	The expected Golden label (110) is not present.	The bus is not installed.	The expected Golden label is present and the bus is active at the correct speed.
AES ID	No labels of correct speed on bus.	The expected Golden label (275) is not present.	The bus is not installed.	The expected Golden label is present and the bus is active at the correct speed.
CMU	No labels of correct speed on bus.	The expected Golden label (270) is not present.	The bus is not installed.	The expected Golden label is present and the bus is active at the correct speed.
CTU	Label 351 bit 27 is set to inactive.	N/A	The bus is not installed.	Label 351 bit 27 is set to OK.

C. Thermal Status

As shown in Figure 4-7, the SATCOM OVERTEMP menu reports the thermal status of system components.

To check the thermal status, on the SATCOM BITE page, press the key next to **OVERTEMP**.

**SYSTEM DESCRIPTION, INSTALLATION, AND MAINTENANCE MANUAL
ARINC 781 SDU, SCM, and FMPA**

	1		5		10		15		20		24						
	1	S	A	T	C	O	M	O	V	E	R	T	E	M	P		1
1L	3															3	1R
		S	D	U													
2L	5	O	K													5	2R
		H	G	A													
3L	7	F	A	I	L											7	3R
		F	M	P	A												
4L	9	O	K													9	4R
5L	11															11	5R
6L	13	<	R	E	T	U	R	N								13	6R

Figure 4-7 SATCOM Overtemp Menu

Table 4-11 describes the information available on the SATCOM OVERTEMP menu.

Table 4-11 SATCOM OVERTEMP Menu

Label	Description	Action
SDU	Reports the SDU thermal status as OK or FAIL.	If the status is FAIL, check the fan operation and temperature at the location of the equipment.
HGA	Reports the HGA thermal status as OK, NO DATA, or FAIL.	If the status is FAIL, check the fan operation and temperature at the location of the equipment.
FMPA	Reports the FMPA thermal status as OK, NO DATA, or FAIL.	If the status is FAIL, check the fan operation and temperature at the location of the equipment.

D. SCM Health

As shown in Figure 4-8, the SATCOM SCM menu reports the status of the communication buses to the SCM and the status of the secure and user configuration tables.

**SYSTEM DESCRIPTION, INSTALLATION, AND MAINTENANCE MANUAL
ARINC 781 SDU, SCM, and FMPA**

	1	5	10	15	20	24	
	1		S A T C O M	S C M			1
1L	3						3 1R
		S T A T U S		S E C U R E	O R T		
2L	5	O K			O K	5	2R
		B U S T O / F R O M		U S E R	O R T		
3L	7	O K			O K	7	3R
4L	9					9	4R
5L	11					11	5R
6L	13	< R E T U R N				13	6R

Figure 4-8 SATCOM SCM Menu

Table 4-12 describes the information available on the SATCOM SCM menu.

Table 4-12 SATCOM SCM Menu

Label	Description	Action
STATUS	Reports the SCM status as OK or FAIL.	If the status is FAIL, return the SCM to the equipment supplier.
BUS TO/FROM	Reports the status of the bus to the SCM as OK or FAIL.	If the status is FAIL, check the connections to the SCM.
SECURE ORT	Reports the status of the Secure ORT as one of the following: NOT LOADED – No ORT in SCM memory. OK – Secure ORT is valid. INVALID – The Secure ORT is corrupted or otherwise invalid and must be reloaded.	If the status is INVALID or NOT LOADED, load a SECURE ORT file.
USER ORT	Reports the status of the User ORT as one of the following: NOT LOADED – No ORT in SCM memory. OK – User ORT is valid. INVALID – The User ORT is corrupted or otherwise invalid and must be reloaded.	If the status is INVALID or NOT LOADED, load a USER ORT file.

E. Subsystem Bus Status

As shown in Figure 4-9, the SATCOM SUBSY BUS menu reports the status of all subsystem buses that provide communication between the components of the system.

	1	5	10	15	20	24	
	1	S A T C O M	S U B S Y	B U S			1
1L	3						1R
		I N - T O P - O U					
2L	5		A N T				2R
		O K / O K					
3L	7		H P A				3R
		O K / O K					
4L	9						4R
5L	11						5R
6L	13	< R E T U R N					6R

Figure 4-9 SATCOM Subsystem Bus Menu

Table 4-13 describes the information available on the SATCOM SUBSY BUS menu. Fields are left blank if the equipment is not included in the installation.

NOTE: Input and output are with respect to the SDU.

Table 4-13 SATCOM SUBSY BUS Menu

Label	Description	Action
ANT	Reports the status of the input and output buses for the antenna as OK, NO DATA, or FAIL.	If status is NO DATA, label 350 is missing—check the bus connections.
HPA	Reports the status of the input and output buses for the HPA as OK, NO DATA, NONE, or FAIL.	If status is NO DATA, label 350 is missing—check the bus connections.

F. RF Path Status

As shown in Figure 4-10, the SATCOM RF PATH menu reports the status the RF paths of a system with an FMPA installed.

**SYSTEM DESCRIPTION, INSTALLATION, AND MAINTENANCE MANUAL
ARINC 781 SDU, SCM, and FMPA**

The load procedure loads an ORT file to the SCM using an ARINC 615A data loader. You can only load ORT data when the aircraft is on the ground and the data load discrete is asserted. When the SDU boots, it compares the ORT file in its memory to that in the SCM. If the ORT files do not match, the SDU loads the file from the SCM into its memory.

Some user ORT parameters can be modified in the SDU ORT. You can reset the SDU ORT to the default values stored in the SCM in the maintenance menus.

(2) Checking the ORT

You can check the content of the ORT file through the maintenance port menus. "SDU MPU" on page 4-2 provides information about accessing the maintenance port menus.

NOTE: The ORT includes many parameters that affect internal operations. These parameters are not meaningful for technicians troubleshooting the satellite communication system.

To check the ORT:

1. In the maintenance port menus, navigate to menu 3.
2. To list the ORT, press **h**.
The list of ORT parameters appears. The list is about eight pages long. Some ORT parameters displayed are system defaults that cannot be modified through the secure and user ORT files.
3. Compare the ORT parameters to the system installed in the aircraft.

I. Contact Product Support

When the troubleshooting procedures do not find a fault and the ARINC 781 system does not function properly, contact Product Support.

Product Support may ask you to capture and send them system specific logs and reports.

To access logs:

1. In the maintenance port menus, navigate to Menu 3.
2. Turn on the text capture feature of the terminal emulator on your computer. In HyperTerminal, click Transfer, and then click Capture Text.
3. To view the call log, in Menu 3, press **f**.
4. To view the event log, in Menu 3, press **s**.

NOTE: The event log includes information about internal events that enable Product Support to monitor the processes of the ARINC 781 system. This log does not provide information for the end user.

5. Turn off the text capture feature of the terminal emulator and send the captured file to Product Support.

**SYSTEM DESCRIPTION, INSTALLATION, AND MAINTENANCE MANUAL
ARINC 781 SDU, SCM, and FMPA**

To access reports:

1. Turn on the text capture feature of the terminal emulator on your computer.
In HyperTerminal, click Transfer, and then click Capture Text.
2. In the maintenance port menus, press EQUAL SIGN (=).
A list of reports appears.
3. To activate a report, type the number next to the report description, and then press ENTER.

NOTE: Product Support will specify the required reports, and may ask you to operate the ARINC 781 equipment while the reports gather information.

4. To stop a report, press EQUAL SIGN (=), then type the number of the report, and then press ENTER.

NOTE: To stop all reports, press X.

5. Turn off the text capture feature of the terminal emulator and send the captured file to Product Support.

3. Adjustment/Alignment Procedures

There are no adjustment/alignment procedures required for the ARINC 781 system.

4. Modification History

The ARINC 781 system currently has no history of modifications.

MAINTENANCE AND REPAIR

This section provides maintenance and repair information for the ARINC 781 system, including the following sections:

- Maintenance
- Repair
- Instructions for Continued Airworthiness
- Visual Inspection and Check

1. Maintenance

The ARINC 781 system does not require routine maintenance.

2. Repair

If functional problems occur, the SDU BITE identifies the faulty LRU.

As per continued airworthiness instructions, if an SDU, SCM, or FMPA is inoperative, use the Standard Practices Chapter of the Aircraft Maintenance Manual to:

- remove the unit
- secure cables and wiring
- collar applicable switches and circuit breakers, and placard them as “inoperative”

Before flight, revise the equipment list and weight and balance data as applicable, and record the removal of the unit in the log book [refer to section 91.213 of the FAR or the aircraft’s minimum equipment list (MEL)].

All repairs must be performed at the equipment supplier factory.

3. Instructions for Continued Airworthiness

Periodic inspections of the mechanical and electrical interfaces of the ARINC 781 system components to the aircraft should be completed as defined by the governing airworthiness body’s Instructions for Continued Airworthiness (ICA) for the installation (for example, Transport Canada, the FAA, the EASA).

Installation of the ARINC 781 SATCOM Avionics System on an aircraft by Supplemental Type Certificate (STC) obligates the aircraft operator to include the maintenance information supplied by this manual in the operator’s Aircraft Maintenance manual and the operator’s Aircraft Scheduled Maintenance Program.

This section provides the special instructions and maintenance requirements for continued airworthiness of the ARINC 781 system.

**SYSTEM DESCRIPTION, INSTALLATION, AND MAINTENANCE MANUAL
ARINC 781 SDU, SCM, and FMPA**

A. Airworthiness Limitations

When applicable, the Airworthiness Limitations section is FAA-approved, and specifies maintenance required under Title 14 Code of Federal Regulations (CFR) Part 43.16 and 14 CFR 91.403 of the Federal Aviation Regulations unless an alternative program has been FAA approved.

This section must be added to the Airplane Maintenance Manuals. The information contained herein supplements the Airplane Maintenance Manuals only in those areas covered by the ARINC 781 system installation. For limitations and procedures not contained in this supplement, consult the basic Airplane Maintenance Manuals.

The inspections and airworthiness limitations specified in this section are FAA approved. This section specifies the inspections and other maintenance required under sections 43.16 and 91.403 of the Federal Aviation Regulations unless an alternative program has been FAA approved.

B. Electrical and Mechanical Inspection and Check

Periodic inspections of the mechanical and electrical interfaces of the A781 system components to the aircraft should be completed as defined by the governing airworthiness body (for example, Transport Canada, the FAA, the EASA).

C. Instructions for Continued Airworthiness

The following paragraphs describe all maintenance requirements and instructions for continued airworthiness of the ARINC 781 avionics system:

1. This manual contains maintenance information for the SDU, SCM, and FMPA, including system description, system operation, installation, test, and fault isolation.
2. Add the following information to the illustrated parts catalog for the aircraft:
 - all part numbers referred to in this manual
 - all LRUs referred to in this manual
3. Add all wiring diagram information contained in this manual to the aircraft operator's appropriate aircraft Wiring Diagram Manuals.
4. No additional or routine maintenance is required for the on-condition SDU, SCM, and FMPA.
5. If an SDU, SCM, or FMPA is inoperative, follow the instructions listed in "Repair" on page 5-1.
6. Return all units to the equipment supplier factory for repair. See Appendix A: Return Material Authorization for detailed removal information and procedures.
7. Install repaired units on the aircraft in accordance with the installation instructions provided in this manual.
8. Make sure that all repaired units are operating before approving them for return to service, using the operational verification tests and procedures provided in this manual.
9. Enter the approval for return to service in the logbook, as required by section 43.9 of the FAR.

**SYSTEM DESCRIPTION, INSTALLATION, AND MAINTENANCE MANUAL
ARINC 781 SDU, SCM, and FMPA**

10. Add the following scheduled maintenance tasks to the aircraft operator's appropriate aircraft maintenance program:
 1. Recommended periodic scheduled servicing tasks: None required.
 2. Recommended periodic inspections: as per the aircraft inspection and maintenance schedule.
 3. Recommended periodic scheduled preventative maintenance tests (tests to determine system condition and/or latent failures): None required.

4. Visual Inspection and Check

Perform the following procedures to inspect the SDU, SCM, and FMPA after installation of the units onto the aircraft.

Follow all approved safety standards and practices during the inspection.

1. Disconnect all circuit breakers to the SDU, SCM, and FMPA and associated systems.

**CAUTION: FAILURE TO DISCONNECT CIRCUIT BREAKERS CAN LEAD TO
INJURY TO THE OPERATOR AND DAMAGE TO THE EQUIPMENT.**

2. Examine the connection for loose, damaged, or missing hardware.
3. Examine cables and connections. Contact Product Support to gauge the severity of the damage if you find:
 - corrosion
 - chafing
 - wear
 - damage
4. Tighten any loose connectors to the manufacturer's recommended value.

Blank Page

APPENDIX A: RETURN MATERIAL AUTHORIZATION

To return equipment to the equipment supplier for repair, this RMA procedure must be followed. Failure to comply with this procedure may result in shipping delays and additional charges.

1. Warranty Returns

Equipment that qualifies for warranty repair can be returned to the equipment supplier for repair or replacement at their discretion. The customer shall pay the shipping costs to the equipment supplier and the equipment supplier will pay the shipping costs to return the repaired/replaced unit to the customer.

2. Non-Warranty Returns

Equipment that fails to work properly because of improper or negligent use, abuse, shipping damage, or any other condition can still be returned to the equipment supplier for repair or replacement at their discretion. The customer will be notified of the cost to repair or replace the unit before invoicing for the repair or replacement. The customer shall pay for the shipping costs to and from the equipment supplier.

3. Repackaging Requirements

ARINC 781 SDU or SCM components must be returned to the equipment supplier in approved shipping containers. Failure to do so may invalidate the warranty.

If SDU or SCM shipping containers are unavailable, they can be ordered from the equipment supplier when requesting the RMA number.

4. RMA Procedure

If it is determined that equipment must be returned to the equipment supplier for repair or overhaul, follow the RMA procedure below.

1. Have the following information ready before calling Product Support:
 - Model (e.g., ARINC 781 SDU)
 - Unit part number (e.g., 1394-A-1100)
 - Serial number
 - Description of failure
 - Aircraft tail number, serial number, and aircraft model number
2. Call Product Support.
3. A Product Support specialist will attempt to resolve the problem by telephone. If equipment must be returned to the equipment supplier, the Product Support Specialist will authorize the R&O Coordinator to issue an RMA number.

SYSTEM DESCRIPTION, INSTALLATION, AND MAINTENANCE MANUAL
ARINC 781 SDU, SCM, and FMPA

4. Pack the equipment in the original shipping container or a container approved by the equipment supplier.
5. Write the RMA number on the outside of the shipping container and on all shipping documents, enclose a copy in the box, and send your prepaid shipment to the equipment supplier.
6. Fax or email the details of the shipment to the R&O Coordinator, including the following information: Shipment date, carrier name, and the waybill number.