



# ARINC 781-200 SDU and SCM

## *System Description, Installation, and Maintenance Manual*

MN-0000243, Revision 1.0

This document provides procedures for the equipment listed below.

<b>Model</b>	<b>Part Number</b>
ARINC 781-200 Satellite Data Unit	1530-A-1100
ARINC 781-200 SDU Configuration Module—Single SBB	1530-A-1300-01
ARINC 781-200 SDU Configuration Module—Dual SBB	1530-A-1300-02

**PROPRIETARY STATEMENT**

This document contains information that is proprietary and confidential to either or both of EMS Technologies Canada, Ltd., or EMS Aviation Inc. (collectively "EMS Aviation") and is supplied on the express condition that it is not to be used for any purpose other than the purpose for which it was issued, nor is it to be copied or communicated in whole or in part, to any third party other than the recipient organization, without the prior written permission of EMS Aviation.

© 2012 EMS Technologies Canada, Ltd., EMS Aviation Inc.

ARINC 781-200 SDU and SCM System Description, Installation, and Maintenance Manual

Document Number: MN-0000243, Revision 1.0

<b>Revision Table</b>		
<b>Revision</b>	<b>ECR</b>	<b>Description</b>

Windows® is a registered trademark of Microsoft Corporation in the United States and other countries. Other product, brand, service, and company names herein are the trademarks of their respective owners.

Our products are under continuous research and development. Any information may therefore be changed without prior notice. EMS Aviation reserves the right to make improvements or changes in the product described in this manual at any time without notice. While reasonable efforts have been made in the preparation of this document to assure its accuracy, EMS Aviation assumes no liability resulting from any errors or omissions in this document, or from the use of the information contained herein.

Printed in Canada.

EMS Aviation

400 Maple Grove Road, Ottawa, Ontario, K2V 1B8, CANADA

EMS Aviation Reception: (613) 591-9064

EMS Aviation Product Support: (888) 300-7415 (calls are routed to an on-call Product Support specialist after regular business hours)

+44 1684 290 020 (UK)

(613) 591-3086 (outside North America)

EMS Aviation E-mail Help: support@emsaviation.com

EMS Aviation Web site: www.emsaviation.com

EMS Aviation Sales and Marketing: 800-600-9759

# CUSTOMER RESPONSE FORM

To help us improve the quality of our product documentation, EMS Aviation would appreciate your comments and suggestions on this publication. Please complete the following customer survey and send to EMS Aviation at:

EMS Aviation  
400 Maple Grove Road  
Ottawa, ON K2C 0P9

E-mail: techdocs@emsaviation.com

## Publication information:

<b>Publication number:</b>	MN-0000243
<b>Publication title:</b>	ARINC 781-200 SDU and SCM System Description, Installation, and Maintenance Manual
<b>Latest issue date:</b>	DATE TBD
<b>Document revision:</b>	1.0

## Customer information:

<b>Name:</b>	
<b>Company:</b>	
<b>Tel:</b>	
<b>Fax:</b>	
<b>Email:</b>	

## Comments and suggestions:

**Date:** \_\_\_\_\_

**Comments:** \_\_\_\_\_

\_\_\_\_\_

\_\_\_\_\_

\_\_\_\_\_

\_\_\_\_\_

\_\_\_\_\_

Blank Page

23-15-30

CR-2  
DATE TBD

## RECORD OF REVISIONS

When revisions are received, insert revised pages, record the date, and initial.

<b>Revision Number</b>	<b>Issue Date</b>	<b>Date Inserted</b>	<b>Inserted by (initial)</b>	<b>Revision Number</b>	<b>Issue Date</b>	<b>Date Inserted</b>	<b>Inserted by (initial)</b>

Blank Page

## SERVICE BULLETIN LIST

Service Bulletin Number	Subject	Manual Rev. Number	Manual Rev. Date

Blank Page





Blank Page

## TABLE OF CONTENTS

### INTRODUCTION

<b>1. Illustration of Equipment .....</b>	<b>INTRO-1</b>
<b>2. Acronyms and Abbreviations .....</b>	<b>INTRO-2</b>
<b>3. Safety Advisories .....</b>	<b>INTRO-4</b>

### SYSTEM DESCRIPTION

<b>1. Inmarsat System Overview.....</b>	<b>1-1</b>
<b>2. Equipment Overview.....</b>	<b>1-2</b>
A. SDU .....	1-3
B. SCM .....	1-3
<b>3. Equipment Specifications .....</b>	<b>1-4</b>
<b>4. System Interfaces.....</b>	<b>1-6</b>
A. SDU .....	1-7
B. SCM .....	1-8
<b>5. User Interfaces .....</b>	<b>1-8</b>
A. MCDU .....	1-8
B. 4-Wire Audio .....	1-8
C. Ethernet .....	1-8
D. POTS .....	1-9
E. CEPT-E1 .....	1-9
F. ISDN .....	1-9
G. Maintenance Port .....	1-9
H. LEDs .....	1-9
I. Self-Test Button .....	1-9
<b>6. Software Description .....</b>	<b>1-10</b>

### SYSTEM OPERATION

<b>1. Registering and Activating Terminals.....</b>	<b>2-1</b>
A. Obtaining ICAO Addresses .....	2-1
B. Choosing Service Providers .....	2-1
C. Registering Terminals .....	2-1

**SYSTEM DESCRIPTION, INSTALLATION, AND MAINTENANCE MANUAL  
ARINC 781-200 SDU and SCM**

<b>2. Using the A781-200 System .....</b>	<b>2-2</b>
A. Operating the MCDU .....	2-2
(1) Screen.....	2-2
(2) Keyboard.....	2-3
(3) Special Symbols.....	2-4
(4) Navigating the MCDU .....	2-4
B. Logging On and Off .....	2-5
(1) Logging On Automatically .....	2-6
(2) Logging On Manually .....	2-6
(3) Logging Off Classic Aero Services.....	2-7
(4) Viewing Log Status.....	2-7
C. Enabling and Disabling the Cabin Telecommunications Unit (CTU) .....	2-8
(1) Disabling CTU calls.....	2-8
(2) Enabling CTU calls.....	2-9
D. Accepting and Making Calls in the Cockpit .....	2-9
(1) Making Cockpit Calls.....	2-9
(2) Call Priority and call Pre-emption.....	2-13
(3) Saving Telephone Numbers in the Telephone Directory .....	2-13
E. Viewing BITE Information .....	2-15
<b>3. Channel Status and System Configuration .....</b>	<b>2-16</b>
A. SBB Status .....	2-16
B. Swift 64 .....	2-18
C. Channel Information and Bit Errors .....	2-20
D. System Part Numbers .....	2-21
<b>4. Maintenance Mode .....</b>	<b>2-23</b>
A. Accessing Maintenance Mode .....	2-24
B. Viewing BITE Information .....	2-26
C. Starting the Intermod Test .....	2-26
D. Viewing Configuration .....	2-26
E. Viewing SATCOM Parameters .....	2-26
F. Viewing SATCOM Options .....	2-27
G. Configuring Audio Options .....	2-28

**INSTALLATION**

<b>1. Advisories .....</b>	<b>3-1</b>
<b>2. Pre-Installation Inspection .....</b>	<b>3-1</b>
A. Unpacking and Inspecting Equipment .....	3-1

**SYSTEM DESCRIPTION, INSTALLATION, AND MAINTENANCE MANUAL  
ARINC 781-200 SDU and SCM**

B. Cabling Notes .....	3-1
<b>3. Installation Procedure.....</b>	<b>3-2</b>
<b>4. Connection Details.....</b>	<b>3-2</b>
A. SDU .....	3-2
B. SCM .....	3-7
<b>5. Owners Requirements Table (ORT).....</b>	<b>3-8</b>
A. ORT Overview .....	3-8
<b>6. Passive Intermodulation (PIM) Test.....</b>	<b>3-8</b>
A. Overview .....	3-8
B. PIM Requirements .....	3-8
C. PIM Test .....	3-9
D. PIM Test Results .....	3-9
(1) PIM Test Overall Status.....	3-9
(2) Directional PIM Test Results .....	3-10
<b>7. Installation and Engineering Drawings.....</b>	<b>3-10</b>
A. Outline and Installation Drawings .....	3-10
B. System Interconnect Drawings .....	3-10

**TEST AND FAULT ISOLATION**

<b>1. Operational and Diagnostic Testing.....</b>	<b>4-1</b>
A. General .....	4-1
B. Test and Fault Isolation Equipment Requirements .....	4-1
C. SDU Maintenance Port Utility (MPU) .....	4-2
(1) Connecting to the MPU.....	4-2
(2) Using the SDU MPU .....	4-3
(3) Menu Item Descriptions .....	4-4
D. Operational and Diagnostic Test Procedures .....	4-5
(1) Test Setup Procedure.....	4-6
(2) Post Test .....	4-6
(3) Installation and Operational Verification Tests .....	4-6
<b>2. Troubleshooting and Fault Isolation .....</b>	<b>4-7</b>
A. Subsystem Health .....	4-7
B. SATCOM System Bus .....	4-8
C. Thermal Status .....	4-10
D. SCM Health .....	4-11
E. Subsystem Bus Status .....	4-13

**SYSTEM DESCRIPTION, INSTALLATION, AND MAINTENANCE MANUAL  
ARINC 781-200 SDU and SCM**

F. RF Path Status .....	4-13
G. USIM and Data Bus Status .....	4-14
H. ORT .....	4-15
(1) Checking the ORT.....	4-15
I. Contact Product Support .....	4-15
<b>3. Adjustment/Alignment Procedures .....</b>	<b>4-16</b>
<b>4. Modification History .....</b>	<b>4-16</b>

**MAINTENANCE AND REPAIR**

<b>1. Maintenance.....</b>	<b>5-1</b>
<b>2. Repair .....</b>	<b>5-1</b>
<b>3. Instructions for Continued Airworthiness .....</b>	<b>5-1</b>
A. Airworthiness Limitations .....	5-2
B. Electrical and Mechanical Inspection and Check .....	5-2
C. Instructions for Continued Airworthiness .....	5-2
<b>4. Visual Inspection and Check.....</b>	<b>5-3</b>

**APPENDIX A: RETURN MATERIAL AUTHORIZATION .....** A-1

<b>1. Warranty Returns .....</b>	<b>A-1</b>
<b>2. Non-Warranty Returns .....</b>	<b>A-1</b>
<b>3. Repackaging Requirements .....</b>	<b>A-1</b>
<b>4. RMA Procedure .....</b>	<b>A-1</b>

## LIST OF FIGURES

Figure INTRO-1 Satellite Data Unit .....	INTRO-1
Figure INTRO-2 SDU Configuration Module .....	INTRO-2
Figure 1-1 Simplified Aeronautical Satellite Communications System .....	1-2
Figure 1-2 A781-200 Avionics System .....	1-3
Figure 1-3 A781-200 Avionics System Block Diagram .....	1-7
Figure 2-1 MCDU Screen .....	2-3
Figure 2-2 A781-200 MCDU Menu Structure .....	2-5
Figure 2-3 SBB menu .....	2-17
Figure 2-4 Swift 64 Menu.....	2-19
Figure 2-5 SATCOM LOG 2 menu .....	2-20
Figure 2-6 SATCOM CONFIG 1 menu .....	2-21
Figure 2-7 SATCOM CONFIG 2 menu .....	2-22
Figure 2-8 SATCOM CONFIG 3 menu .....	2-23
Figure 2-9 Maintenance Mode MDCU Menu Structure .....	2-24
Figure 2-10 SATCOM PARMS .....	2-27
Figure 2-11 SATCOM OPTIONS.....	2-28
Figure 2-12 CONFIG AUDIO 1/2 .....	2-29
Figure 2-13 CONFIG AUDIO 2/2 .....	2-30
Figure 3-1 Top Plug Pin Deviations .....	3-5
Figure 3-2 Mid Plug Pin Deviations .....	3-6
Figure 3-3 ARINC 781-200 SDU Outline and Installation Drawing, 1530-E-1100 Rev B00 (Sheet 1 of 2) .....	3-11
Figure 3-4 ARINC 781-200 SDU Outline and Installation Drawing, 1530-E-1100 Rev B00 (Sheet 2 of 2) .....	3-13
Figure 3-5 ARINC 781-200 SCM Outline and Installation Drawing, 1530-E-1300 Rev C00 (Sheet 1 of 2) .....	3-15
Figure 3-6 ARINC 781-200 SCM Outline and Installation Drawing, 1530-E-1300 Rev C00 (Sheet 2 of 2) .....	3-17
Figure 3-7 ARINC 781-200 System Interconnect Drawing, 1530-B-1001 Rev C00 (Sheet 1 of 3)... 3-19	
Figure 3-8 ARINC 781-200 System Interconnect Drawing, 1530-B-1001 Rev C00 (Sheet 2 of 3)... 3-21	
Figure 3-9 ARINC 781-200 System Interconnect Drawing, 1530-B-1001 Rev C00 (Sheet 3 of 3)... 3-23	
Figure 4-1 Maintenance Cable .....	4-2

**SYSTEM DESCRIPTION, INSTALLATION, AND MAINTENANCE MANUAL  
ARINC 781-200 SDU and SCM**

Figure 4-2 SATCOM Subsystem Health Menu ..... 4-8  
Figure 4-3 SATCOM System Bus Menu ..... 4-9  
Figure 4-4 SATCOM Overtemp Menu ..... 4-11  
Figure 4-5 SATCOM SCM Menu ..... 4-12  
Figure 4-6 SATCOM Subsystem Bus Menu ..... 4-13  
Figure 4-7 SATCOM RF Path Menu ..... 4-14  
Figure 4-8 SATCOM USIM/DATA Menu ..... 4-15



## LIST OF TABLES

Table 1-1 SDU Physical Characteristics and Specifications.....	1-4
Table 1-2 SCM Physical Characteristics and Specifications .....	1-5
Table 1-3 ARINC 781-200 SDU and SCM RTCA/DO-160E Environmental Characteristics .....	1-6
Table 1-4 SDU System Interfaces .....	1-8
Table 1-5 SDU LED Status.....	1-9
Table 2-1 A781-200 System Log Status.....	2-7
Table 2-2 SBB Menu .....	2-17
Table 2-3 Swift 64 Menu.....	2-19
Table 2-4 SATCOM LOG 2 Menu.....	2-20
Table 2-5 SATCOM CONFIG 1 Menu .....	2-21
Table 2-6 SATCOM CONFIG 2 Menu .....	2-22
Table 2-7 SATCOM CONFIG 3 Menu .....	2-23
Table 2-8 SATCOM PARMS Menu .....	2-27
Table 2-9 SATCOM OPTIONS Menu.....	2-28
Table 2-10 SATCOM CONFIG AUDIO 1 Menu.....	2-29
Table 2-11 SATCOM CONFIG AUDIO 2 Menu.....	2-30
Table 3-1 SDU Rear Connector Pin Deviations.....	3-2
Table 3-2 SDU Front Connector DSUB and RJ45 Pin Assignment.....	3-7
Table 3-3 SCM D-Type Connector Pin Assignment .....	3-7
Table 4-1 List of Required Test Equipment .....	4-2
Table 4-2 Maintenance Port Connection Settings .....	4-3
Table 4-3 Menu 1 Item Descriptions.....	4-4
Table 4-4 Menu 2 Item Descriptions.....	4-4
Table 4-5 Menu 3 Item Descriptions.....	4-5
Table 4-6 Test Setup Procedure.....	4-6
Table 4-7 Post Test Procedure .....	4-6
Table 4-8 Power-On Test Procedure.....	4-7
Table 4-9 SATCOM Subsystem Health Menu .....	4-8
Table 4-10 Bus Status Indicators.....	4-9
Table 4-11 SATCOM OVERTEMP Menu .....	4-11
Table 4-12 SATCOM SCM Menu .....	4-12
Table 4-13 SATCOM SUBSY BUS Menu.....	4-13
Table 4-14 SATCOM RF PATH Menu .....	4-14

**SYSTEM DESCRIPTION, INSTALLATION, AND MAINTENANCE MANUAL  
ARINC 781-200 SDU and SCM**

Table 4-15 SATCOM USIM/DATA Menu..... 4-15

## INTRODUCTION

This manual provides the specifications, principles of operation, and information necessary to install the ARINC 781-200 Avionics SATCOM System, including the Satellite Data Unit (SDU) and SDU Configuration Module (SCM).

This document is divided into the following sections:

- System Description
- System Operation
- Installation
- Test and Fault Isolation
- Maintenance and Repair

**NOTE:** An Illustrated Parts List is not included with this manual.

Only qualified avionics personnel who are knowledgeable in the technical and safety issues related to the installation of aircraft communications equipment should perform the installation procedures provided in this manual.

This manual includes general installation guidelines only; it is not intended to provide specific procedures for every type of installation.

If necessary, the information in this manual will be revised. Before attempting the installation procedures presented in this manual, verify that you have a complete and up-to-date release of this document.

### 1. Illustration of Equipment

Figure INTRO-1 shows the SDU.

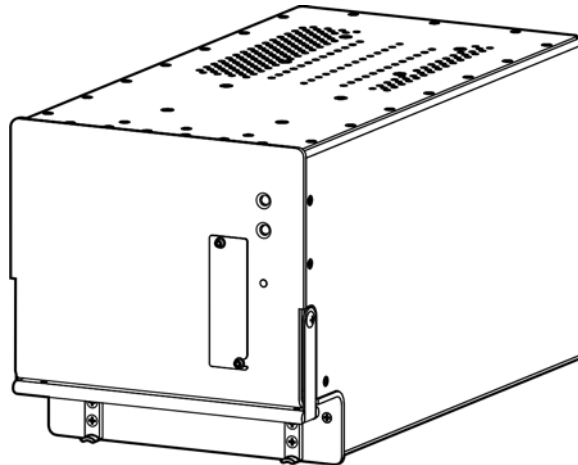
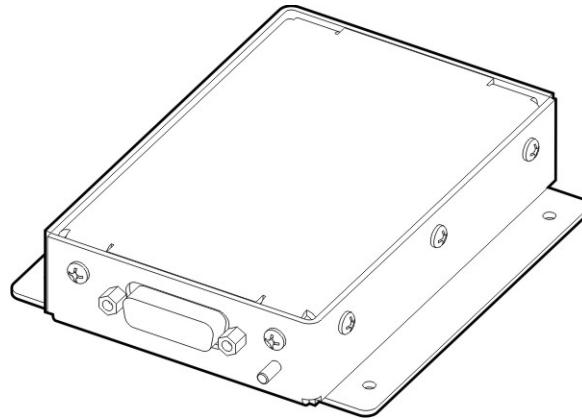

Figure INTRO-1 Satellite Data Unit

**SYSTEM DESCRIPTION, INSTALLATION, AND MAINTENANCE MANUAL  
ARINC 781-200 SDU and SCM**

Figure INTRO-2 shows the SCM.



**Figure INTRO-2 SDU Configuration Module**

## **2. Acronyms and Abbreviations**

AES	Aircraft Earth Station
AMSS	Aeronautical Mobile Satellite Services
AORE	Atlantic Ocean Region-East
AORW	Atlantic Ocean Region-West
APAC	Asia-Pacific
BIT	Built-In-Test
BITE	Built-In-Test Equipment
BSU	Beam Steering Unit
CEPT	Comite Europeen des Postes et Telecommunications
CTU	Cabin Telecommunications Unit
DLNA	Diplexer/Low-Noise Amplifier
DITS	Digital Information Transfer System
EASA	European Aviation Safety Agency
EMEA	Europe, Middle East, and Africa
ESD	Electrostatic Discharge
FAA	Federal Aviation Administration
FAR	Federal Aviation Regulation

**SYSTEM DESCRIPTION, INSTALLATION, AND MAINTENANCE MANUAL  
ARINC 781-200 SDU and SCM**

FMS	Flight Management System
GES	Ground Earth Station
GND	Ground
HGA	High Gain Antenna
HPA	High Power Amplifier
ICA	Instructions for Continued Airworthiness
ICAO	International Civil Aviation Organization
I/O	Input/Output
IOR	Indian Ocean Region
IRS	Inertial Reference System
ISDN	Integrated Services Digital Network
LES	Land Earth Station
LRU	Line Replaceable Unit
MCDU	Multi-purpose Control Display Unit
MCU	Modular Concept Unit
MES	Mobile Earth Station
MHz	Megahertz
MOPS	Minimum Operational Performance Standards
MPU	Maintenance Port Utility
ORT	Owner Requirement Table
POR	Pacific Ocean Region
POTS	Plain Old Telephone System
RF	Radio Frequency
RMA	Return Material Authorization
RTN	Return
Rx	Receive
SATCOM	Satellite Communications
SBB	SwiftBroadband (Inmarsat)
SCM	SDU Configuration Module
SDU	Satellite Data Unit
SLU	Software Logical Unit

**SYSTEM DESCRIPTION, INSTALLATION, AND MAINTENANCE MANUAL  
ARINC 781-200 SDU and SCM**

STC	Supplemental Type Certificate
Tx	Transmit
USIM	Universal Subscriber Identity Module
UUT	Unit Under Test
VSWR	Voltage Standing Wave Ratio

### 3. Safety Advisories

Warnings, cautions, and notes in this manual provide the reader with the following information:

- A **WARNING** describes an operation, procedure, or condition that, if not obeyed, could cause injury or death.
- A **CAUTION** describes an operation, procedure, or condition that, if not obeyed, could cause damage to the equipment.
- A **NOTE** provides supplementary information or explanatory text that makes it easier to understand and perform procedures.

All personnel who install, operate, and maintain the ARINC 781-200 SDU and SCM, and associated test equipment must know and obey the safety precautions listed below. The procedures provided in this manual assume that the person performing installation or maintenance tasks is familiar with and obeys standard aviation shop and safety practices.

The general safety advisories include the following:

**WARNING: THE ARINC 781-200 AVIONICS SYSTEM INCLUDES COMPONENTS THAT RADIATE RF AND MICROWAVE EMISSIONS IN THE BANDWIDTH OF 1626.5 TO 1660.5 MHZ.**

**WARNING: BEFORE HANDLING ANY UNIT OR COMPONENT, GROUND THE REPAIR OPERATOR THROUGH A CONDUCTIVE WRIST STRAP OR OTHER DEVICE THAT USES A 470 KILOHM OR 1 MEGAOHM SERIES RESISTOR TO PREVENT INJURY.**

**CAUTION: TURN OFF POWER BEFORE DISCONNECTING ANY EQUIPMENT FROM WIRING. DISCONNECTING THE EQUIPMENT WITHOUT TURNING POWER OFF MAY CAUSE VOLTAGE TRANSIENTS THAT CAN DAMAGE THE EQUIPMENT.**



**ATTENTION**

OBSERVE PRECAUTIONS  
FOR HANDLING  
ELECTROSTATIC  
SENSITIVE DEVICES

**CAUTION: THIS EQUIPMENT INCLUDES ITEMS THAT ARE ELECTROSTATIC DISCHARGE SENSITIVE (ESDS) DEVICES. ESDS DEVICES ARE SUBJECT TO DAMAGE BY EXCESSIVE LEVELS OF VOLTAGE AND/OR CURRENT. THE LOW-ENERGY SOURCE THAT MOST COMMONLY DESTROYS ESDS**

**SYSTEM DESCRIPTION, INSTALLATION, AND MAINTENANCE MANUAL  
ARINC 781-200 SDU and SCM**

DEVICES IS THE HUMAN BODY, WHICH, IN CONJUNCTION WITH NONCONDUCTIVE GARMENTS AND FLOOR COVERINGS, GENERATES AND RETAINS STATIC ELECTRICITY. TO ADEQUATELY PROTECT ESDS DEVICES, THE DEVICE AND EVERYTHING THAT CONTACTS IT MUST BE BROUGHT TO GROUND POTENTIAL BY PROVIDING A CONDUCTIVE SURFACE AND DISCHARGE PATHS. USE STANDARD INDUSTRY PRECAUTIONS TO KEEP RISK OF DAMAGE TO A MINIMUM WHEN TOUCHING, REMOVING, OR SERVICING THE EQUIPMENT.

Blank Page



## SYSTEM DESCRIPTION

This section includes basic information about the A781-200 system, including the following sections:

- Inmarsat System Overview
- Equipment Overview
- Equipment Specifications
- System Interfaces
- User Interfaces
- Software Description

### 1. Inmarsat System Overview

This section provides an overview of the Inmarsat satellite communications system and networks.

Satellite communication systems provide users with long-range voice and data communication by accessing global satellite and ground communications networks. Satellite communication systems include global satellite networks, Land Earth Stations (LESs), Ground Earth Stations (GESs), Aircraft Earth Stations (AESs), and Mobile Earth Stations (MESs).

The LES/GES is the part of the satellite communication system that is on the ground. These numerous, international stations are responsible for routing voice and data calls from the MES/AES to their destinations around the world. The MES/AES is the part of the satellite communication system that is on the aircraft. GES and AES are the terms associated with Aero-H+ services. LES and MES are terms associated with other satellite communication services.

Inmarsat is an international organization that operates and maintains multiple geostationary satellites and satellite networks (I-3 and I-4). For more information about I-3 and I-4 satellite beam coverage, refer to the Inmarsat website—[www.inmarsat.com](http://www.inmarsat.com).

I-3 satellites provide Inmarsat services for aviation (Aero H+ and Swift 64), shipping, and land-mobile users. The satellites connect to ground telecommunication systems through a network of GESs. Each I-3 satellite is located over an Ocean Region (OR)—the current OR names are:

- Atlantic Ocean Region-East (AOR-E)
- Atlantic Ocean Region-West (AOR-W)
- Indian Ocean Region (IOR)
- Pacific Ocean Region (POR)

**SYSTEM DESCRIPTION, INSTALLATION, AND MAINTENANCE MANUAL  
ARINC 781-200 SDU and SCM**

I-4 satellites provide worldwide SwiftBroadband (SBB service). Each I-4 satellite has 19 wide spot beams, 228 narrow spot beams, and is capable of accommodating many separate, simultaneous SBB sessions. The SBB service and I-4 satellites support broadband applications. The current I-4 satellites are:

- AMERICAS
- EMEA (Europe, Middle East, and Africa)
- APAC (Asia-Pacific)

The satellite communication avionics (A781-200 system), in conjunction with an antenna subsystem, act as an AES/MES. The combined system provides users with a data and voice communications link to the satellite network and global telecommunications system.

Figure 1-1 illustrates a simplified satellite communications system.

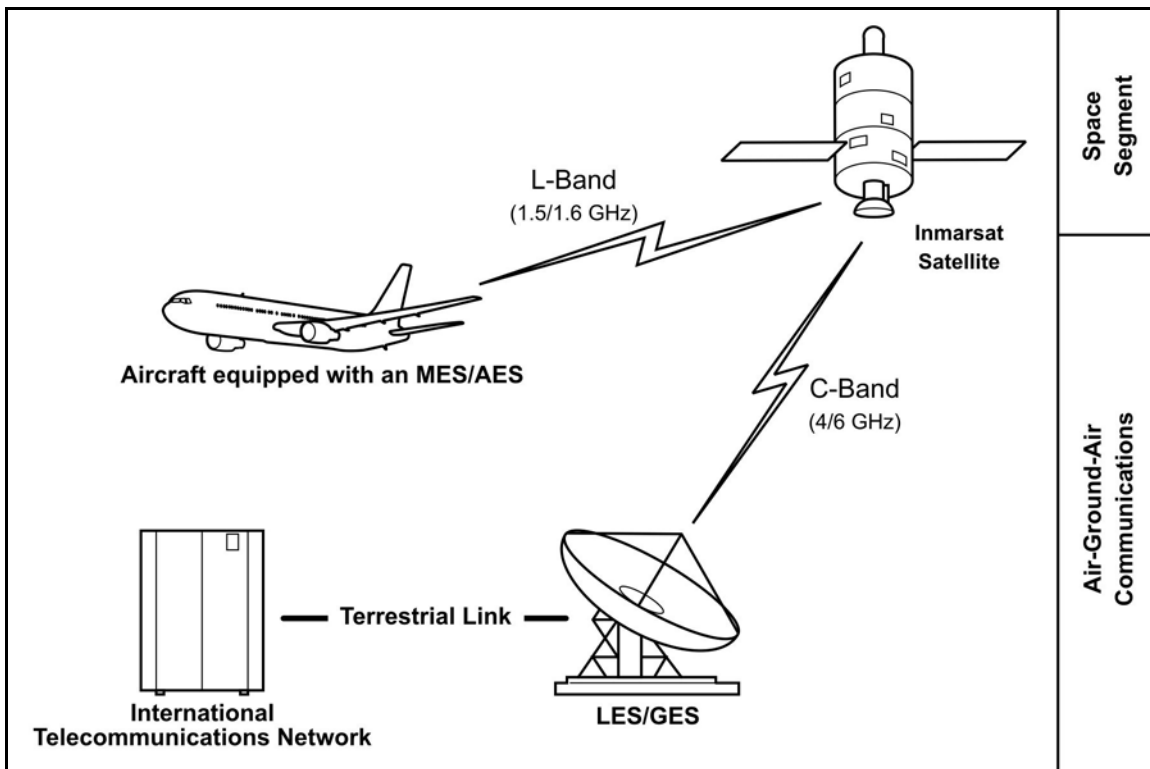

**Figure 1-1 Simplified Aeronautical Satellite Communications System**

## **2. Equipment Overview**

The A781-200 system, in combination with the antenna sub-system, provides Aeronautical Mobile Satellite Services (AMSS) by facilitating airborne satellite communications over the Inmarsat network, including the following services:

**SYSTEM DESCRIPTION, INSTALLATION, AND MAINTENANCE MANUAL  
ARINC 781-200 SDU and SCM**

- Classic Aero-H+—Provides packet data services at 600 bps, 1200 bps, or 10500 bps over the PRT channel combination and half-rate circuit switched voice or data service over the C channel.
- Swift 64—Provides packet switched Mobile Packet Data Service (MPDS) or 64kbps circuit-switched Unrestricted Digital Information (UDI).
- SwiftBroadband (SBB)—Provides AMBE+2 voice (circuit-switched) and broadband packet switched services. The equipment can achieve aggregate rates of 432 kbps, but data rates may vary with network load and signal quality. The equipment can be configured for either single or dual SBB.

The A781-200 system consists of the Satellite Data Unit (SDU) and the Satellite Data Unit Configuration Module (SCM).

Figure 1-2 illustrates the A781-200 system.

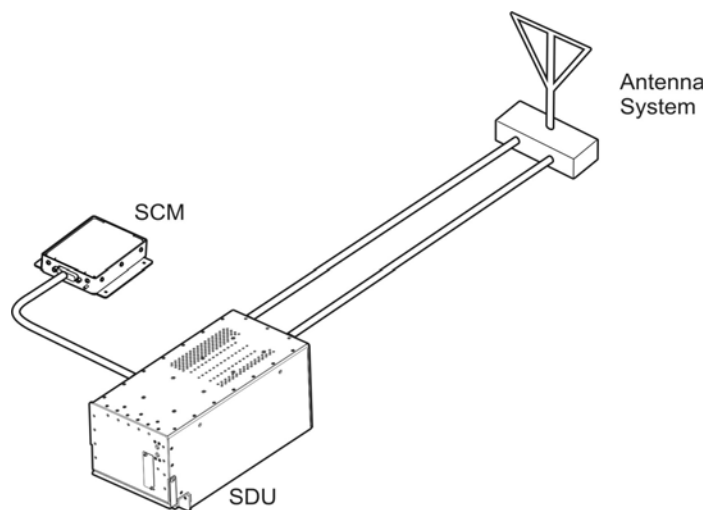

**Figure 1-2 A781-200 Avionics System**

**A. SDU**

The SDU is the central communications processing and control unit and largely determines the functionality of the complete SATCOM system. It manages interfaces, routing and priorities, and call channel establishment and tear down. The SDU provides RF power amplification using an internal high power amplifier (HPA).

The SDU is divided into several Shop Replaceable Units (SRUs) that are electrically connected via the backplane. Various SRUs are also connected using RF cables.

**B. SCM**

The SCM is an external peripheral of the SDU and provides a dedicated interface to the SDU. It stores Secure and User ORTs (Owner Requirement Tables), a Swift 64 Forward ID and the keys to enable either single or dual SBB capability. The SCM can accommodate up to four Universal Subscriber Identity Modules (USIM) that store subscriber information for the SBB network.

**SYSTEM DESCRIPTION, INSTALLATION, AND MAINTENANCE MANUAL  
ARINC 781-200 SDU and SCM**

By storing configuration information independent of the SDU, the SCM facilitates efficient SDU replacement. A new SDU that replaces a faulty SDU does not require any configuration. All configuration information is obtained from the SCM.

### 3. Equipment Specifications

This section includes the physical and environmental characteristics of the A781-200 SDU and SCM.

Table 1-1 provides a summary of the physical characteristics and equipment specifications of the SDU component.

**Table 1-1 SDU Physical Characteristics and Specifications**

CHARACTERISTIC	SPECIFICATION
<b>RELATED DOCUMENTS</b>	
ARINC characteristics	ARINC 781-4 Mark 3 Aviation Satellite Communications System ARINC 600 Air Transport Avionics Equipment Interfaces
RTCA documents	DO-254, Design Assurance Guidance for Airborne Electronic Hardware DO-178B, Software Considerations in Airborne Systems and Equipment Certification DO-160E, Environmental Conditions and Test Procedures for Airborne Equipment DO-210, Minimum Operational Performance Standards (MOPS) for Geosynchronous Orbit Aeronautical Mobile Satellite Services (AMSS) Avionics
<b>SDU SPECIFICATIONS</b>	
Physical Size	
Length	37.24 cm (14.66 in)
Width	19.35 cm (7.62 in)
Height	19.93 cm (7.85 in)
Weight	11.30 kg (24.9 lbs)
Heating and Cooling	
Cooling Air	ARINC 600
Flow Rate	50 kg/hr 40°C (max) air
Pressure Drop	5 ± 3 mm H <sub>2</sub> O
Mounting Information	6 MCU tray as per ARINC 600

**SYSTEM DESCRIPTION, INSTALLATION, AND MAINTENANCE MANUAL  
ARINC 781-200 SDU and SCM**

**Table 1-1 SDU Physical Characteristics and Specifications (Continued)**

CHARACTERISTIC	SPECIFICATION
Electrical Interfaces	
Power/Control interface	as per ARINC 781
Power Requirements	
Input Voltage (AC)	96 to 122 V AC, 300 to 900 Hz
Power Consumption	400 VA

Table 1-2 provides a summary of the physical characteristics and equipment specifications of the SCM component.

**Table 1-2 SCM Physical Characteristics and Specifications**

CHARACTERISTIC	SPECIFICATION
<b>RELATED DOCUMENTS</b>	
ARINC characteristics	ARINC 781 Mark 4 Aviation Satellite Communications System
RTCA documents	DO-254, Design Assurance Guidance for Airborne Electronic Hardware DO-160E, Environmental Conditions and Test Procedures for Airborne Equipment
<b>SCM SPECIFICATIONS</b>	
Physical Size	
Length	11.43 cm (4.5 in)
Width	10.16 cm (4.0 in)
Height	2.54 cm (1.0 in)
Weight	0.454 kg (1.0 lbs)
Mounting Information	4 x 0.125" holes on 3.3" x 3.5" spacing, per attachment 1-6 of ARINC 781
Electrical Interfaces	
Power/Control interface	as per ARINC 781
Power Requirements	+ 12 V $\pm$ 5% (derived from SDU)

**SYSTEM DESCRIPTION, INSTALLATION, AND MAINTENANCE MANUAL  
ARINC 781-200 SDU and SCM**

Table 1-3 lists the RTCA/DO-160E environmental characteristics of the SDU and SCM.

**Table 1-3 ARINC 781-200 SDU and SCM RTCA/DO-160E Environmental Characteristics**

<b>Section</b>	<b>Environmental Condition</b>	<b>Category</b>
4.0	Temperature and Altitude	F2
4.5.1	Ground Survival Low	F2
4.5.2	Operating Low Ambient	F2
4.5.3	Short Time Operating High	F2
4.5.4	Operating High Ambient	F2
4.5.5	In Flight Loss of Cooling	F2
	Ground Survival Low Temperature	F2
	Ground Survival High Temperature	F2
4.6.1	Altitude	F2
5	Temperature Variation	B
6	Humidity	B
7	Operational Shock and Crash Safety	B
8.5.2	Vibration Standard – Random	S, Curve B
9.0	Explosive Atmosphere	E
15	Magnetic Effect	A
16.5.1.4	Power Input (ac) Interruptions	A(WF)X
17	Voltage Spike	A
18	Audio Frequency Conducted Susceptibility (ac)	K(WF)
19	Induced Signal Susceptibility	CW
20	Radio Frequency Susceptibility	R
21	Emission of RF Energy	L
22	Lightning Induced Transient Susceptibility	A3E3X
24	Icing	A
25	Electrostatic Discharge (ESD)	A

#### **4. System Interfaces**

This section describes the A781-200 system interfaces.

Figure 1-3 illustrates the block diagram of the A781-200 avionics system.

**SYSTEM DESCRIPTION, INSTALLATION, AND MAINTENANCE MANUAL  
ARINC 781-200 SDU and SCM**

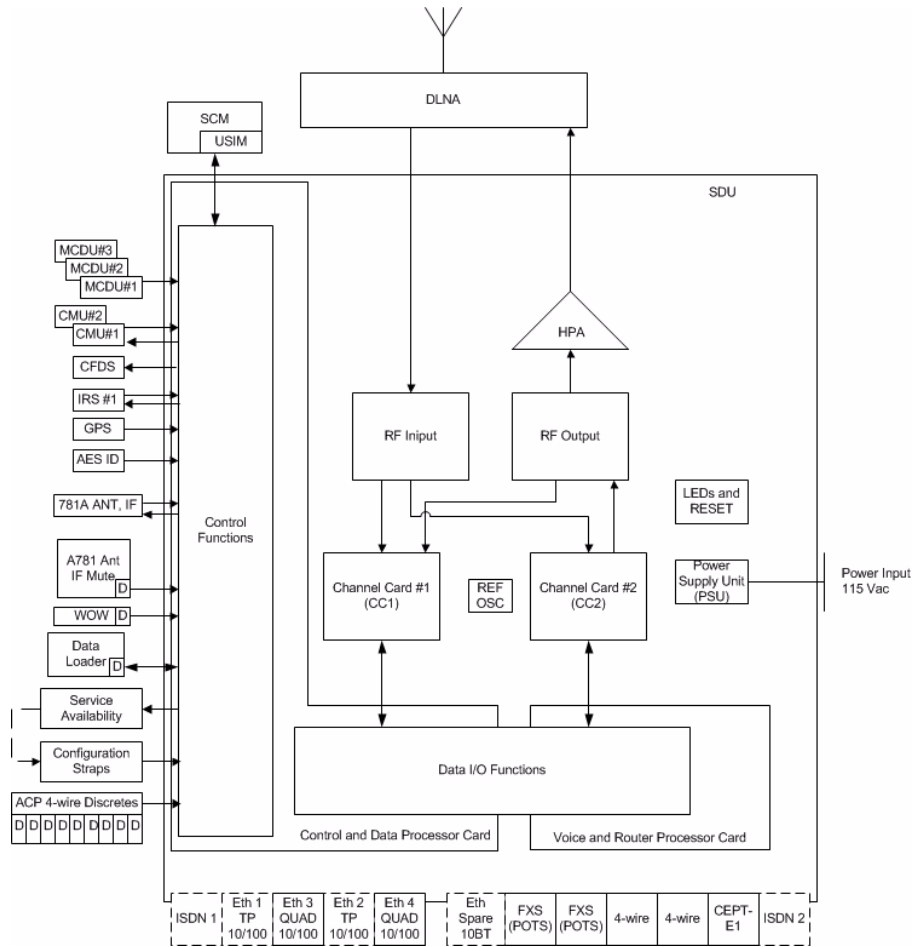

**Figure 1-3 A781-200 Avionics System Block Diagram**

**NOTE:** On the aircraft only the Ethernet 3, POTS, 4-Wire and CEPT-E1 ports are supported.

**A. SDU**

The SDU is divided into the following LRUs:

- Channel Cards (2)
- Control and Data Processor Card
- Voice and Router Processor Card
- Power Amplifier
- ARINC Backplane
- DIN Backplane
- 10 MHz Oven Controlled Crystal Oscillator
- Power Supply

**SYSTEM DESCRIPTION, INSTALLATION, AND MAINTENANCE MANUAL  
ARINC 781-200 SDU and SCM**

The major interfaces of the SDU are listed in Table 1-4.

**Table 1-4 SDU System Interfaces**

<b>System Interface</b>	<b>Description</b>
ACU/BSU (x1)	Antenna Control Unit/Beam Steering Unit
MCDU (x3)	Multi-Purpose Control and Display Unit
ACARS CMU (x2)	Aircraft Communication Addressing and Reporting System Communication Management Unit
IRS (x2)/GPS (x1)	Inertial Reference System/Global Positioning System
SCM (x1)	SDU Configuration Module
AES ID (x1)	Aircraft Earth Station Identification
Servicing	Front Panel Accessible Service Port for data log retrieval
Button	Initiated Self-Test
RF	Transmit/receive to the DLNA
Antenna subsystem	ARINC 781 Antenna Subsystem
Miscellaneous	ARINC discrete input, outputs, and configuration straps

**B. SCM**

The SCM does not provide any interfaces other than a dedicated interface to the SDU.  
The SCM is powered by the SDU.

## **5. User Interfaces**

This section describes the A781-200 SDU interfaces that enable users to access Inmarsat services and monitor the operation of the A781-200 system.

NOTE: There are no user interface associated with the SCM.

**A. MCDU**

The MCDU is a device that uses an ARINC 429 interface per ARINC 739, which lets you communicate with individual instruments on an aircraft, including the Flight Management System (FMS), very high frequency (VHF) radio, and the SDU.

The SDU supports three MCDUs.

**B. 4-Wire Audio**

The SDU supports two 4-wire audio interfaces.

**C. Ethernet**

The SDU supports one Ethernet data interface.



**D. POTS**

The SDU supports two POTS interfaces.

**E. CEPT-E1**

The SDU supports one CEPT-E1 interface.

**F. ISDN**

Two ISDN interfaces are currently not supported.

**G. Maintenance Port**

The SDU is equipped with a maintenance port, located on its front panel. The maintenance port provides the physical connection to a password-protected Maintenance Port Utility (MPU) that provides a system interface for users or service personnel who need to monitor or troubleshoot the system.

For more information on configuring the maintenance port, refer to "Connecting to the MPU" on page 4-2.

**H. LEDs**

The front panel of the SDU has two LEDs to indicate unit status:

- One green LED labelled **Power**
- One red LED labelled **Fault**

Table 1-5 provides information about the LED signals.

**Table 1-5 SDU LED Status**

<b>Power LED Status</b>	<b>Fault LED Status</b>	<b>Description of SDU Status</b>
LED is on	LED is off	No fault detected
LED is on	LED is steadily on as long as the fault exists	LRU fault detected
LED is on	Flashing at 1 Hz with a 50% duty cycle while the fault exists	System fault detected but not isolated to the LRU
Alternating flashing of Power and Fault LEDs		Self-test in progress

**I. Self-Test Button**

The front panel of the SDU has a recessed button labelled **Test**:

- To reset the unit, press and hold the Test button for at least 5 seconds
- To initiate self-test (when no LEDs are flashing), momentarily press the Test button
- When the self test completes (power on or user initiated) the Power LED will illuminate steady for a period of 60 seconds and then it will deactivate for the duration of operation.

**SYSTEM DESCRIPTION, INSTALLATION, AND MAINTENANCE MANUAL  
ARINC 781-200 SDU and SCM**

NOTE: During initial power-up or self-test execution, a momentary press of the self-test button is ignored.

The LEDs indicate the results of the self-test. Table 1-5 provides information about the meaning of LED signals.

## **6. Software Description**

All operating software meets RTCA/DO-178B Level D requirements.

The SCM does not contain any software. Only configuration parameters are stored in the SCM.

The SDU software is not partitioned. The software is modular and modules run on individual Software Logical Units (SLUs) within the SDU:

- Each channel card has a single SLU
- Control and Data Processor card has a Control SLU and a Data SLU
- Voice and Router card has a Voice SLU and a Router SLU

## SYSTEM OPERATION

The SDU is an integral component in an AES. Together with the SCM, DLNA, Antenna, and HGA subsystem, it provides AMSS by facilitating airborne satellite communication services over the Inmarsat network. These services comprise Classic Aero-H+, Swift 64, and SwiftBroadband (SBB).

The SCM is a dedicated peripheral of the SDU and stores aircraft specific installation configuration critical to the operation of the AES.

This section provides basic information on using the A781-200 system.

### 1. Registering and Activating Terminals

Registering and activating the A781-200 system has the following steps:

- Obtaining ICAO Addresses
- Choosing Service Providers
- Registering Terminals

#### A. Obtaining ICAO Addresses

Obtain your ICAO address from your local aeronautical authority. Your service provider will require this address when you register.

#### B. Choosing Service Providers

Contact Inmarsat for an up-to-date list of Inmarsat Service Providers using the following contact information:

Inmarsat  
99 City Road, London  
EC1Y 1AX

Tel: +44 20 7728 1000  
Fax: +44 20 728 1044

Customer Care  
Tel: +44 20 7728 1777  
Fax: +44 20 7728 1142  
Email: [customer\\_care@inmarsat.com](mailto:customer_care@inmarsat.com)

Web address: [www.inmarsat.com](http://www.inmarsat.com)

#### C. Registering Terminals

Contact your Inmarsat service provider and ask for a registration for service activation of Aircraft Earth Station form. With this form, you can register for SBB and Aero H+ services. The services available depend on your service provider.

**SYSTEM DESCRIPTION, INSTALLATION, AND MAINTENANCE MANUAL  
ARINC 781-200 SDU and SCM**

To complete the registration form you need the following information:

- Customer information (address and contact information)
- Service provider details (obtained from your ISP)
- System and terminal information (terminal type, manufacturer, model number, serial number of terminal)
- ICAO 24 bit technical address for Aero H+ services
- IMEI and IMSI (printed on the SCM label) for SBB services
- Aircraft information (tail number, fuselage/airframe number, manufacturer and model, and country of registration)
- List of services required (for example, Aero H+ data-2, SBB PS and SBB CS services)

## **2. Using the A781-200 System**

This section describes how to perform the following tasks:

- Operating the MCDU
- Logging On and Off
- Enabling and Disabling the Cabin Telecommunications Unit (CTU)
- Accepting and Making Calls in the Cockpit
- Viewing BITE Information

### **A. Operating the MCDU**

This section provides information about the MCDU screen and the keyboard.

#### **(1) Screen**

The MCDU displays all data on the screen, as shown in Figure 2-1.

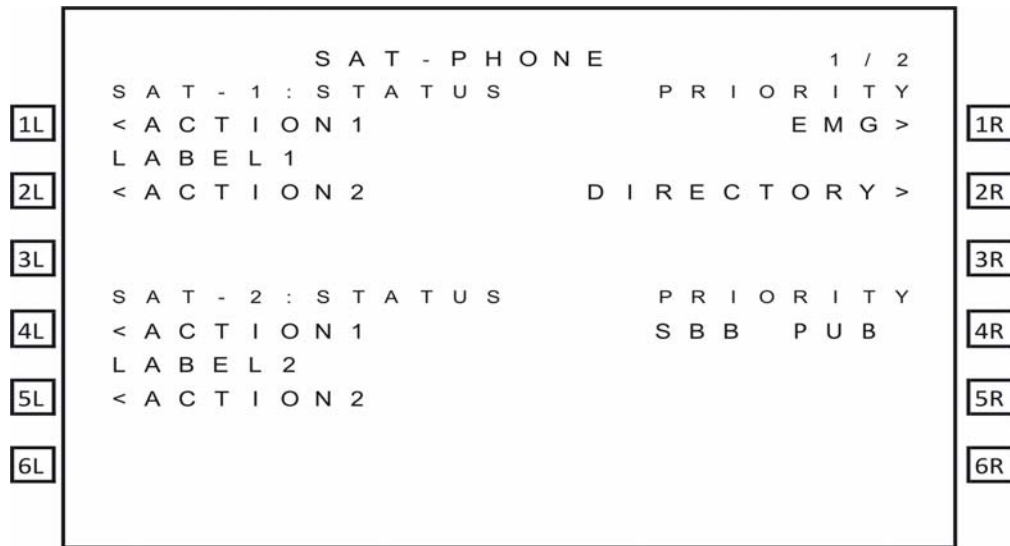

Figure 2-1 MCDU Screen

**NOTE:** The SAT PHONE 1/2 menu shown in Figure 2-1 is an example where classic (SAT-1) and SBB (SAT-2) cockpit calls are supported. Depending on the secure ORT parameter settings, the prompts "SAT-1" and "SAT-2" can be replaced to display any message limited to five characters.

The top of the screen displays the title of the menu on the screen. The bottom of the screen (Line 14) is the scratchpad that displays information that you enter on the keyboard.

The MCDU has six buttons on each side of the screen that activate MCDU functions. Figure 2-1 displays these buttons on the left and right sides of the screen. When the functions corresponding to a button are available, the function is displayed beside the button.

Other lines on the MCDU screen display information relevant to the function or status of the A781-200 system.

## (2) Keyboard

The MCDU's keyboard includes a set of numeric keys and a set of alphabetic keys, both of which you can use to enter data into the MCDU.

The keyboard may include preset keys, such as the following:

- The **IDX** or **MAIN MENU** key: this key returns you to the MCDU's main menu.
- The **CLR** key: this key clears any text you type into the scratchpad.
- The **NEXT PAGE** key: this key brings up the next page of a menu if one is available.
- The **PREV PAGE** key: this key brings up the previous page of a menu if one is available.

**SYSTEM DESCRIPTION, INSTALLATION, AND MAINTENANCE MANUAL  
ARINC 781-200 SDU and SCM**

(3) Special Symbols

Because of space constraints on the screen, the MCDU uses a number of special symbols to indicate actions:

- **<** and **>** appear at the far left or right to indicate that another menu page is available in that direction or that a function is available for that label.
- **NUMBER/NUMBER** appears to tell you which page out of how many pages you are viewing. For example, **1/3** would appear when you are on page 1 of 3 pages in total.

(4) Navigating the MCDU

The MCDU includes a number of menus, as shown in Figure 2-2.

**SYSTEM DESCRIPTION, INSTALLATION, AND MAINTENANCE MANUAL  
ARINC 781-200 SDU and SCM**

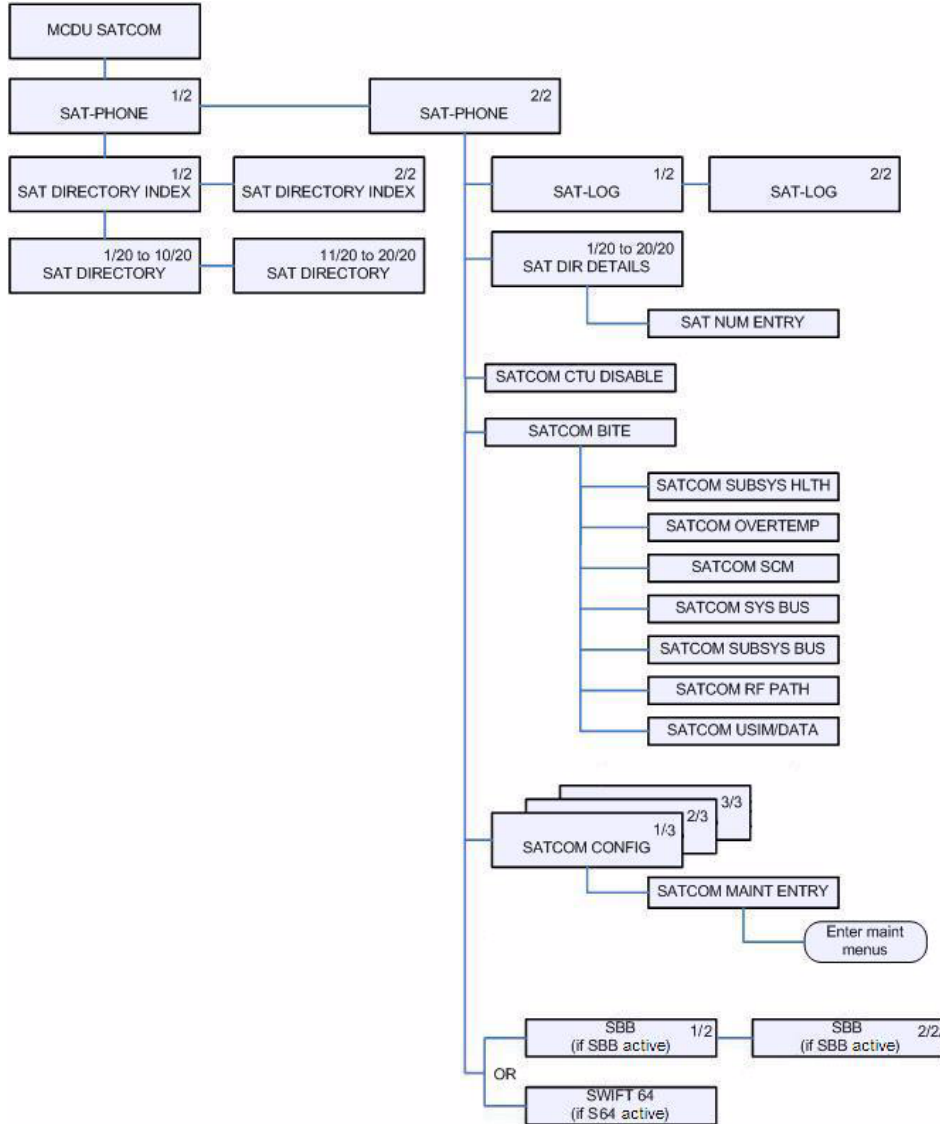

**Figure 2-2 A781-200 MCDU Menu Structure**

**B. Logging On and Off**

Using the MCDU, you can log on to the satellite network manually or automatically:

- Manual Logon—constrains the logon to use a satellite that you select
- Automatic Logon—logs on using the best available satellite as defined by the ORT

If specified in the ORT, the initial system logon happens immediately after the A781-200 system powers up, with no MCDU input required. If the ORT is not configured as such, you must initiate the logon from the MCDU (MANUAL LOG-ON or AUTO LOG-ON command). For more information, see "ORT Overview" on page 3-8.

**SYSTEM DESCRIPTION, INSTALLATION, AND MAINTENANCE MANUAL**  
**ARINC 781-200 SDU and SCM**

You can watch the progress of the logon on the SATCOM LOG 1/2 menu, or simply wait until the prompt on the SAT-PHONE 1/2 menu indicates the service is available for use.

(1) Logging On Automatically

When you initiate an automatic logon, the system selects a satellite and GES based on the preferences specified in the ORT.

To log on automatically:

1. On the SAT-PHONE 1/2 menu, press the button next to **LOG**.

The SATCOM LOG menu appears.

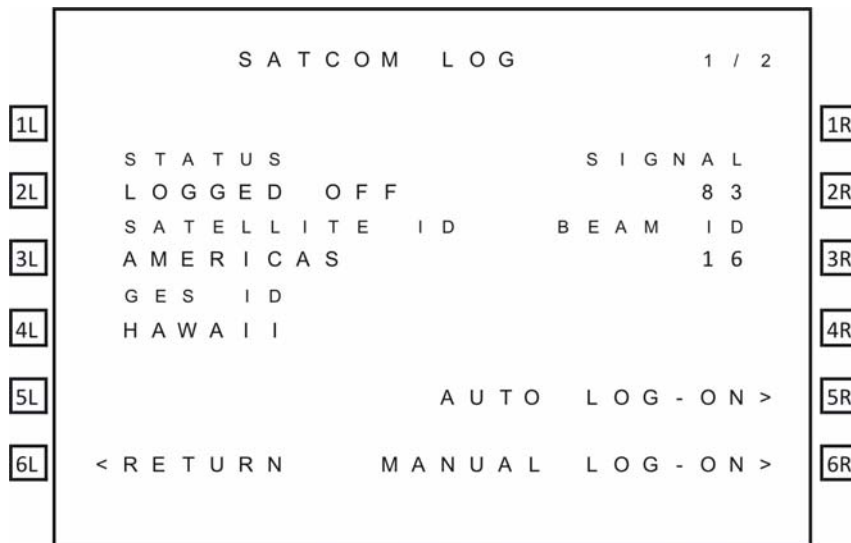

2. On the SATCOM LOG menu, press the button next to **AUTO LOG-ON**.

The MCDU returns to the SAT-PHONE 1/2 menu and the CLSSC and SBB channels are updated with READY status after the logon completes.

NOTE: The MCDU does not display the AUTO LOG-ON and MANUAL LOG-ON functions when the A781-200 system is already logged on.

NOTE: On the SAT-PHONE 1/2 menu, CLSSC shows the Classic Aero channel status and SBB shows the SBB channel status. The A781-200 system logs on the Classic Aero channels first, and then logs on the SBB channels.

(2) Logging On Manually

To log on manually, you must select a satellite and GES.

To log on manually:

1. On the SAT-PHONE 1/2 menu, press the button next to **LOG**.

The SATCOM LOG menu appears.

2. Press the button next to **SATELLITE ID** until the MCDU screen shows the satellite ID to which you want the A781-200 system to log on.



**SYSTEM DESCRIPTION, INSTALLATION, AND MAINTENANCE MANUAL  
ARINC 781-200 SDU and SCM**

3. Press the button next to **GES ID** until the MCDU screen shows the GES to which you want the A781-200 system to log on.
4. On the SATCOM LOG menu, press the button next to **MANUAL LOG-ON**.

The MCDU returns to the SAT-PHONE 1/2 menu and updates the SAT-L and SAT-R channels with READY status after the log on completes.

**NOTE:** SAT-L shows the Classic Aero channel status and SAT-R shows the SBB channel status. The A781-200 system logs on the Classic Aero channels first, and then searches for SBB or Swift 64 services on the satellite determined by the Classic Aero log-on.

(3) Logging Off Classic Aero Services

**WARNING:** This option does not log off SBB or Swift 64 services. If either of these services is running, they will continue to run and potential charges could be made to the cabin. To completely log off, power down the A781-200 system.

To log off:

1. On the SAT-PHONE 1/2 menu, press the button next to **LOG**.  
The SATCOM LOG menu appears.
2. On the SATCOM LOG menu, press the button next to **LOG-OFF**.  
The A781-200 system logs off the satellite network.

(4) Viewing Log Status

The log status defines whether the A781-200 system is logged on or logged off. Valid values are shown in Table 2-1.

**Table 2-1 A781-200 System Log Status**

<b>Log Status</b>	<b>Description</b>
SAFE MODE	Configuration error detected
HSR NOT READY	High stability oscillator is in a warming condition
ANT NOT READY	Antenna is reporting test state
AES ID NOT READY	Displayed until a non-zero ICAO address is present
NAV DATA UNAVAIL	Insufficient navigation data available
CC NOT READY	Channel card has not fully booted
LOGGED OFF	A781-200 system not logged on to the satellite network. Awaiting input from the user
TUNING TO SAT	Tuning and scanning for reception from the selected satellite
DET SYS TABLE	Updating the Satellite table
SPOT BEAM SEARCH	Selecting the optimal spot beam
WAIT LOGON CONF	Awaiting the logon confirmation from the satellite
WAIT LOGON ACK	Awaiting for logon acknowledge from the GES
LOGGED ON	Successfully logged on to GES

**Table 2-1 A781-200 System Log Status (Continued)**

Log Status	Description
REJECT-TEMPORARY	Logon rejected by the GES, but the condition is temporary
REJECT-PERMANENT	Logon rejected by the GES, and the condition is permanent
REJECT-INV PARAM	Logon rejected by the GES due to invalid parameters, and the condition is permanent
REJECT-AES INVAL	ICAO address was not accepted by the GES, the condition is permanent
LOGGING OFF	Starting the logoff process

To view log status:

1. On the SAT-PHONE 1/2 menu, press the button next to **LOG**.  
The SATCOM LOG menu appears.
2. The log status appears on the line below **STATUS**.

**C. Enabling and Disabling the Cabin Telecommunications Unit (CTU)**

To use the CTU, the CEPT-E1 interface needs to be enabled in the Secure ORT. See "Owners Requirements Table (ORT)" on page 3-8.

You can enable and disable the calls to and from the CTU from the SAT-PHONE 2/2 menu.

(1) Disabling CTU calls

To disable CTU calls:

1. On the SAT-PHONE 2/2 menu, press the button next to **ENABLED**.  
The CTU DISABLE menu appears.

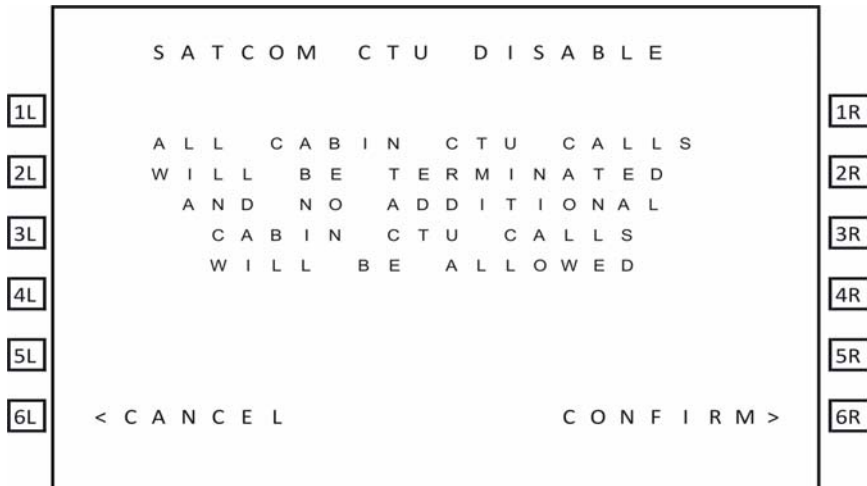

2. To disable all CTU calls, press the button next to **CONFIRM**.

**SYSTEM DESCRIPTION, INSTALLATION, AND MAINTENANCE MANUAL  
ARINC 781-200 SDU and SCM**

(2) Enabling CTU calls

To enable CTU calls:

- On the SAT-PHONE 2/2 menu, press the button next to **DISABLED**. The MCDU displays ENABLED under CTU CALLS.

**D. Accepting and Making Calls in the Cockpit**

You can make air- to-ground and accept ground-to-air voice calls using the A781-200 system, the MCDU, the Audio Control Panel (ACP), and a 4-wire cockpit headset.

The 4-wire cockpit headset supports Push to Talk (PTT) mode. Push to Talk mode mimics the way an HF radio functions. The user's voice is only transmitted when the 'Mic On' input is asserted i.e. pushed.

(1) Making Cockpit Calls

You can manually dial calls or dial previously saved telephone numbers from the MCDU's telephone directory.

When the SDU cannot complete a call, the MCDU displays CALL FAIL. The call and event logs provide information about the cause of the call failure. Call and event logs are accessible to avionics technicians through the maintenance port of the SDU.

(a) Making Calls from the Scratchpad

A call can only be initiated using the buttons on the MCDU.

To make a call:

1. On the MCDU main menu, press the button next to **SAT**.
2. Enter a number in the MCDU scratchpad using the following pattern.

00+CC+NNN+NUMBER

00 is the access code for international calls, CC is the country code, and NNN is the city or area code.

- No hyphens are needed when entering the number in the MCDU scratchpad.
- 18 is the maximum number of characters that you can enter.
- To delete an incorrect character, press CLR on the sratchpad.

The number appears at the bottom of the MCDU screen and MANUAL ENTRY appears under the channel label.

SYSTEM DESCRIPTION, INSTALLATION, AND MAINTENANCE MANUAL  
ARINC 781-200 SDU and SCM

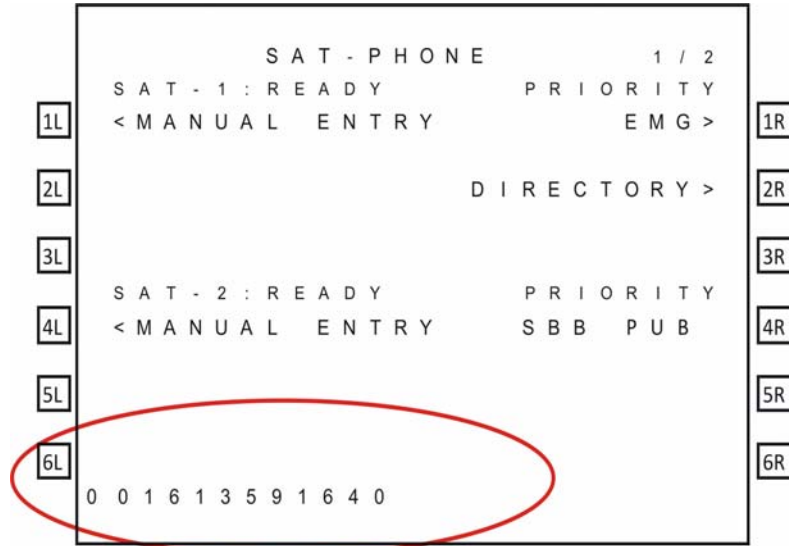

3. Press the button next to **MANUAL ENTRY**.

NOTE: If an entry has MANUAL ENTRY under the SAT-1 label, that entry can be dialed on Classic Aero channels. If an entry has MANUAL ENTRY under the SAT-2, that entry can be dialed on SBB channels.

MAKE CALL and the number appear under the channel label.

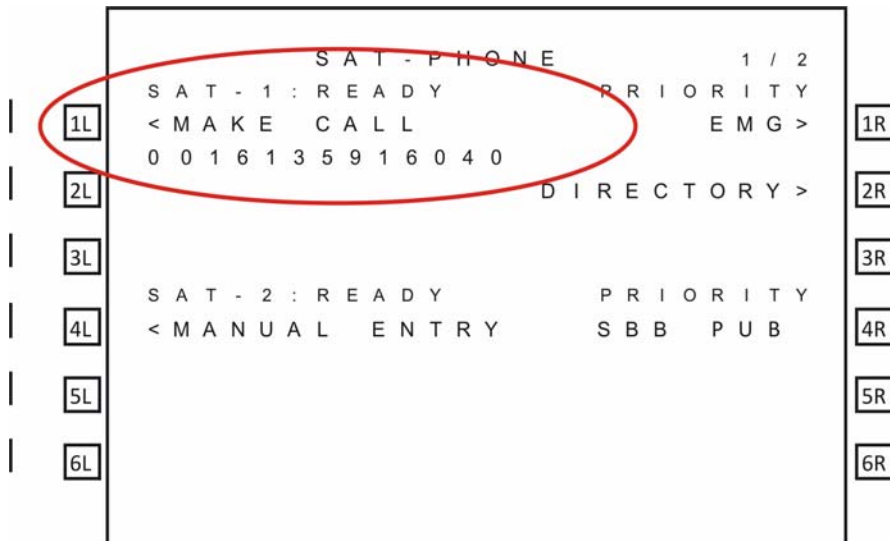

4. To set the priority, press the button next to **PRIORITY**.

Note: You can only set the priority for a Classic call. All calls made over SBB are public priority.

**SYSTEM DESCRIPTION, INSTALLATION, AND MAINTENANCE MANUAL  
ARINC 781-200 SDU and SCM**

5. On the MCDU, press the button next to **MAKE CALL**.

The channel status displays DIALING, RINGING and then ANSWERED when connected.

(b) Making Calls from the Telephone Directory

You can make voice calls from the numbers you have saved in the MCDU's telephone directory. Numbers can be saved in the telephone directory using the MCDU or the ORT. For more information on the ORT, see "ORT Overview" on page 3-8.

To make a call from the telephone directory:

1. On the MCDU main menu, press the button next to **SAT**.
2. On the MCDU keyboard, press the **NEXT PAGE** key to advance to the second page of the **SAT-PHONE** menu, and then press the button next to **DIRECTORY**.

The SAT DIRECTORY INDEX menu appears.

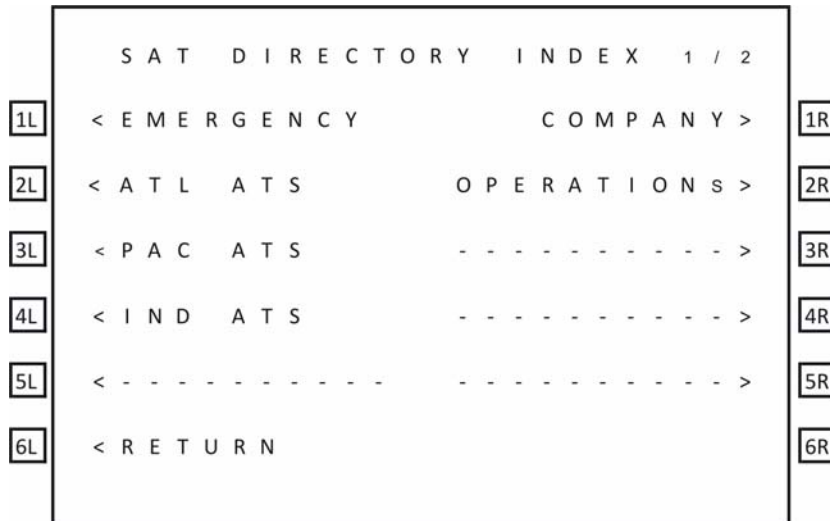

3. To access phone numbers in a directory, press the button next to a directory name.

The SAT DIRECTORY menu appears.

**NOTE:** If an entry has the < symbol in the SAT-1 column, that entry can be dialed on Classic Aero channels. If an entry has the > symbol in the SAT-2 column, that entry can be dialed on SBB channels. If there is no symbol, the entry cannot be dialed on that channel.

**SYSTEM DESCRIPTION, INSTALLATION, AND MAINTENANCE MANUAL  
ARINC 781-200 SDU and SCM**

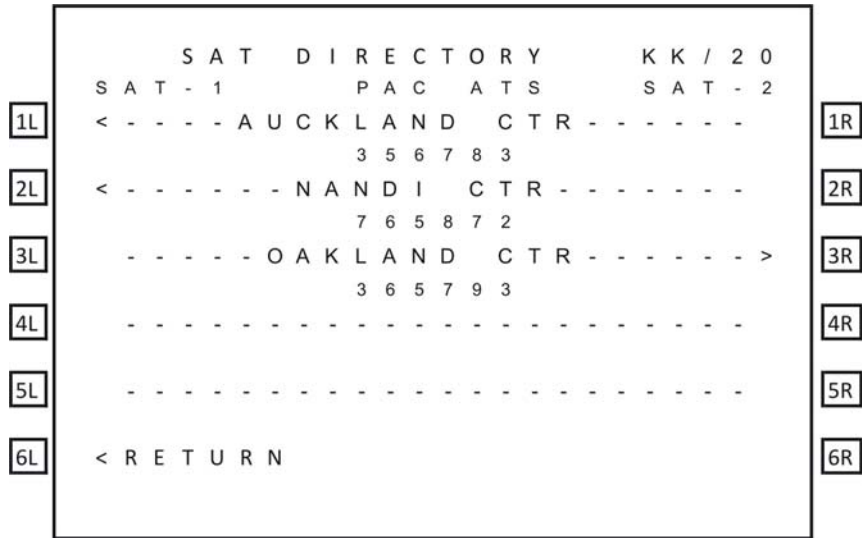

4. Press the button to the left or right of the number you wish to dial.
  - Pressing the left button loads the number on the Classic Aero channel
  - Pressing the right button loads the number on the SwiftBroadband channel.

The MCDU returns to page one of the SAT-PHONE menu and the number is displayed under the selected channel.

5. To set the priority, press the button next to **PRIORITY**.

Note: You can only set the priority for a Classic call. All calls made over SBB are public priority.

6. Press the button next to **MAKE CALL**.

The channel status displays DIALING, RINGING and then ANSWERED when connected.

(c) Answering Calls

To answer a call:

- On the **ACP**, transition the **MIC ON** discrete from **ON HOOK** to **OFF HOOK**.
- OR

On the MCDU, press the button next to **ANSWER** to answer the call or press the button next to **REJECT** to reject the call.

(d) Ending Calls

To end a call:

- On the MCDU on the SAT-PHONE 1/2 menu, press the button next to **END CALL**

OR

On the ACP, assert the **Place/End** switch.

**SYSTEM DESCRIPTION, INSTALLATION, AND MAINTENANCE MANUAL  
ARINC 781-200 SDU and SCM**

(2) Call Priority and call Pre-emption

The A781-200 system has four priority settings for calls:

- 1 Emergency
- 2 High
- 3 Low
- 4 Public

(a) Setting the Call Priority

You can set the priority for an air-to-ground 4-wire Classic call before making the call.

This priority setting allows for preemption of existing lower priority cockpit Aero H+ calls if insufficient satellite resources exist to establish an independent call, and for preemption of calls and services within the cabin.

If the 4-wire Classic call is the same priority as an existing call, the established call will be retained and the new call will be queued.

Cockpit calls over SBB are Public priority calls. You can not change the priority.

All calls made from the interfaces other than the cockpit 4-wire phones or ACARS CMU are Public priority calls.

(b) Receiving a Priority Call

If a cockpit call is in progress and a higher priority ground-to-air call is received, the higher priority incoming call will preempt the existing call. The preemption is automatic, and the caller in the cockpit has no option to choose between calls.

(c) Pre-empting Calls

You can preempt an existing priority 4 cabin call with a priority 4 cockpit call.

- To preempt a call, on the SAT-PHONE 1/2 menu press the button next to **PREEMPT**.
- To QUEUE a call, on the SAT-PHONE 1/2 menu press the button next to **QUEUE**.
- To remove a call from the QUEUE, on the SAT-PHONE 1/2 menu press the button next to **END QUEUE**.

(3) Saving Telephone Numbers in the Telephone Directory

You can save telephone numbers to the MCDU's telephone directory to use later, and you can dial telephone numbers from the telephone directory.

NOTE: Saving telephone numbers in the directory may be inhibited by ORT options.

**SYSTEM DESCRIPTION, INSTALLATION, AND MAINTENANCE MANUAL  
ARINC 781-200 SDU and SCM**

To save telephone numbers to the telephone directory:

1. Navigate to the SAT-PHONE 2/2 menu and press the button next to **DIR DETAILS**.



The SAT DIR DETAILS menu appears and shows directory page 1. There are 20 phone directories with five phone number entries available in each directory.



2. Use **NEXT PAGE** and **PREV PAGE** to navigate to the directory in which you want to add or modify a phone number entry.
3. To modify an entry, press the button next to the entry. To add a new entry press the button next to an empty line.



**SYSTEM DESCRIPTION, INSTALLATION, AND MAINTENANCE MANUAL  
ARINC 781-200 SDU and SCM**

4. Type the name associated with the telephone number in the scratchpad and then press the button next to the name field on the MCDU screen.
  - The maximum number of characters for a name is 14.
5. Type the phone number in the scratchpad using the following pattern.  
00CC-NNN-NUMBER.  
00 is the access code for international calls, CC is the country code, and NNN is the city or area code.
  - The maximum number of characters for a number is 18 including hyphens.
  - Hyphens are not necessary. If you wish to use hyphens press the +/- key on the scratchpad.
6. Press the button next to the phone number field on the MCDU screen.
7. Press the button next to **PRIORITY** to select a priority for the phone number.
8. To save the entry, press the button next to **STORE**. To cancel the new entry, press the button next to **CANCEL**.
9. Press the button next to **CONFIRM**.

The entry is saved.

**NOTE:** You can protect directory entries using the Phonebook ORT parameter. If an entry is protected, it cannot be modified or deleted. For more information about the Phonebook ORT parameter, refer to "ORT Overview" on page 3-8.

#### **E. Viewing BITE Information**

From the SATCOM BITE menu, you can view BITE information to determine subsystem health.

To view BITE information:

1. On the MCDU main menu, press the button next to **SAT**.
2. On the MCDU keyboard, press the **NEXT PAGE** key to advance to the second page of the SAT-PHONE menu, and then press the button next to **SATCOM BITE**.

The SATCOM BITE menu appears.

**SYSTEM DESCRIPTION, INSTALLATION, AND MAINTENANCE MANUAL  
ARINC 781-200 SDU and SCM**

```

                S A T C O M   B I T E
1L   S D U                               S Y S   B U S > 1R
      O K                               O K
2L   < S U B S Y   H L T H           S U B S Y   B U S > 2R
      O K                               O K
3L   < O V E R T E M P           C H : S B B   C L S C 3R
      O K                               2 / 2       1 / 1
4L   < S C M                       R F   P A T H > 4R
      O K                               O K
5L                               U S I M / D A T A > 5R
                               2 / 2       1 / 1
6L   < R E T U R N                               6R
```

You can view the following information from this screen:

- SDU status on the line below **SDU**
- Overall health of all subsystem components (SCM, DLNA, and HGA) on the line below **SUBSY HLTH**
- Thermal status of the SDU and HGA on the line below **OVERTEMP**
- SCM health on the line below **SCM**
- Peripheral LRU bus status on the line below **SYS BUS**
- Subsystem bus status on the line below **SUBSY BUS**
- The number of functioning SBB channels and Classic channels below **CH-SBB CLSC**
- RF path status on the line below **RF PATH**
- USIM and data bus status on the line below **USIM/DATA**

NOTE: Valid values for status are OK and FAIL. If the status of a subsystem is FAIL, press the button next to the subsystem to view the details.

To view more information about the health of a particular subsystem, press the button next to the name of the subsystem. For more information about the various MCDU menu screens, see "Troubleshooting and Fault Isolation" on page 4-7.

### **3. Channel Status and System Configuration**

#### **A. SBB Status**

Depending on the SCM installed with the SDU, the A781-200 system can support single SBB or dual SBB.

In single SBB mode, the SDU supports up to 2 simultaneous voice calls (one on classic and one on SBB) on the CEPT-E1 interface. In this mode, the SBB menu has one page.

In dual SBB mode, the SDU supports up to 3 simultaneous voice calls (one on classic and two on SBB) on the CEPT-E1 interface. In this mode, the SBB menu has two pages.

**SYSTEM DESCRIPTION, INSTALLATION, AND MAINTENANCE MANUAL  
ARINC 781-200 SDU and SCM**

As shown in Figure 2-3, the SBB1 menu provides information about the status of the SBB service.

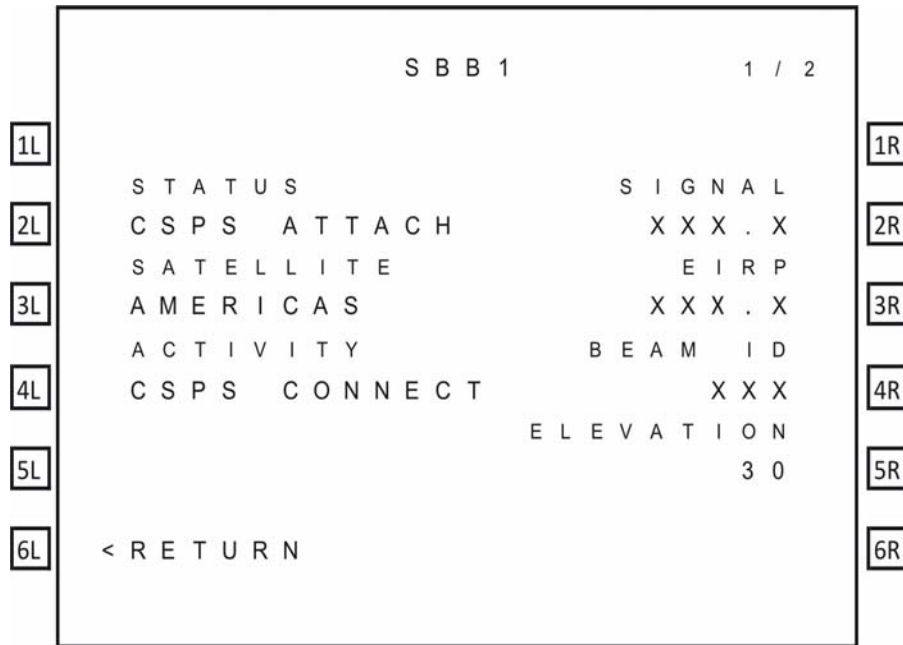

**Figure 2-3 SBB menu**

Table 2-2 describes the information available in the SBB menu.

**Table 2-2 SBB Menu**

Label	Description
Status	<p>The status of the SBB channel. Possible values are:</p> <ul style="list-style-type: none"> <li>• SAFE MODE—configuration error detected</li> <li>• HSR NOT READY—high stability oscillator is warming</li> <li>• USIM WARMING—USIM is warming</li> <li>• NOT READY—channel card has not yet started registration, and may be waiting on the Classic card</li> <li>• SEARCHING—listening for satellite signals</li> <li>• ATTACHING—satellite identified and attach has begun</li> <li>• CS ATTACH—attach complete, circuit-switch granted</li> <li>• PS ATTACH—attach complete, packet-switch granted</li> <li>• CSPS ATTACH—attach complete, circuit-switch and packet-switch granted</li> <li>• ATTACH-FAIL-###—### is the 3GPP cause code</li> <li>• NO SERVICE—selected satellite does not support SBB</li> </ul>

Table 2-2 SBB Menu

Label	Description
Satellite	The selected ocean region.
Activity	The activity status of the SBB service. Possible values are: <ul style="list-style-type: none"><li>• CS CONNECT—Circuit Switched services in use</li><li>• PS CONNECT—Packet Switched services in use</li><li>• CSPS CONNECT—Circuit Switched services and Packet Switched services in use</li><li>• NONE —No services in use.</li></ul>
Signal	The current signal quality.
EIRP	The EIRP setting of the channel.
Beam ID	The current beam ID for the service.
Elevation	The computed elevation angle for the antenna pointing vector.

**B. Swift 64**

The A781-200 system can be configured to support Swift 64 by the aircraft manufacturer at the time of installation. When the A781-200 system is configured in SWIFT 64 mode, SBB is not supported.

When configured in Swift 64 mode, calls can only be made using Classic services.

Swift 64 can support either packet switched MPDS or 64kbps circuit-switched UDI data services.

As shown in Figure 2-4, the Swift 64 menu provides information about the status of the Swift 64 service.

**SYSTEM DESCRIPTION, INSTALLATION, AND MAINTENANCE MANUAL  
ARINC 781-200 SDU and SCM**

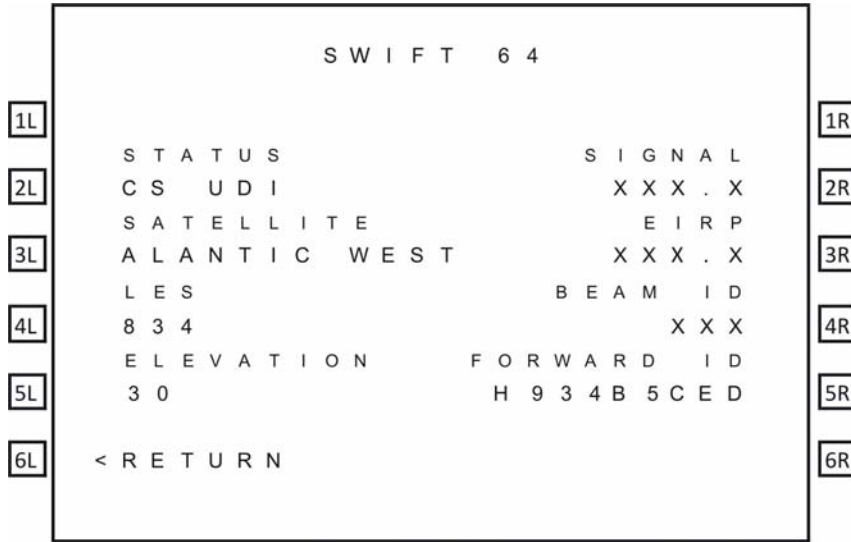

**Figure 2-4 Swift 64 Menu**

Table 2-3 describes the information available in the Swift 64 menu.

**Table 2-3 Swift 64 Menu**

Label	Description
Status	The status of the Swift 64 channel. Possible values are: <ul style="list-style-type: none"> <li>• CS UDI—Circuit Switched Unrestricted Digital Information</li> <li>• MPDS—Mobile Packet Data Service</li> <li>• NO SERVICE—selected satellite does not support Swift 64</li> <li>• SEARCHING—listening for satellite signals</li> <li>• READY—channel card is ready</li> <li>• NOT READY—channel card has not yet started registration, and may be waiting on the Classic card</li> </ul>
Satellite	The selected ocean region.
LES	Land Earth Station ID
Elevation	The computed elevation angle for the antenna pointing vector.
Signal	The current signal quality.
EIRP	The EIRP setting of the channel.

**Table 2-3 Swift 64 Menu**

Label	Description
Beam ID	The current beam ID for the service.
Forward ID	Swift 64 forward ID which the A781-200 system uses to access Inmarsat Swift 64 services.

**C. Channel Information and Bit Errors**

As shown in Figure 2-5, the SATCOM LOG 2 menu provides information about the current channel and the bit error rate.

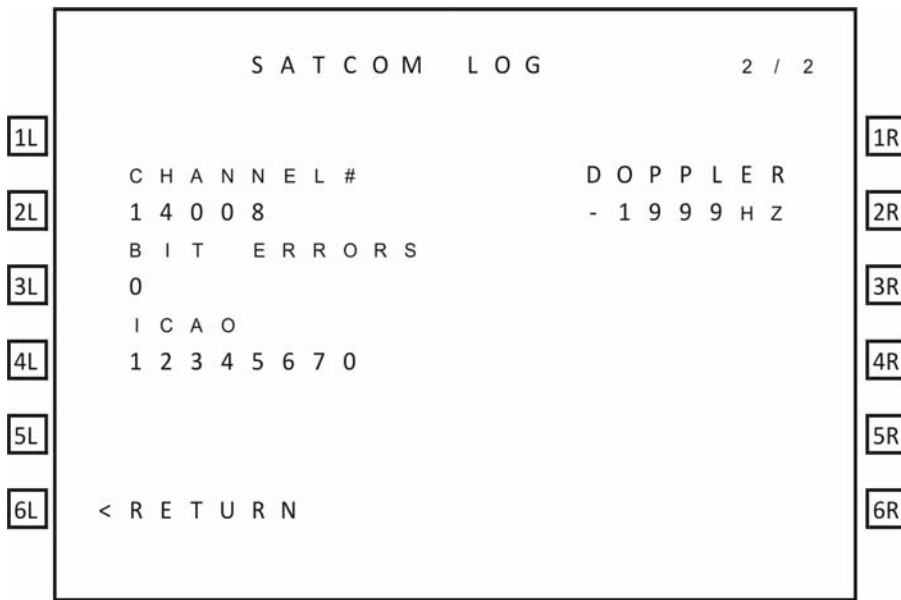

**Figure 2-5 SATCOM LOG 2 menu**

Table 2-4 describes the information available in the SATCOM LOG 2 menu.

**Table 2-4 SATCOM LOG 2 Menu**

Label	Description
Channel #	Channel number representation of the P channel, displayed only when the SDU is logged on, otherwise the display is blank.
Bit Errors	The raw bit error rate.
ICAO	The current ICAO address.
Doppler	The doppler correction.

**D. System Part Numbers**

As shown in Figure 2-6, the SATCOM CONFIG 1 menu provides the hardware part numbers of the SDU and the SCM.

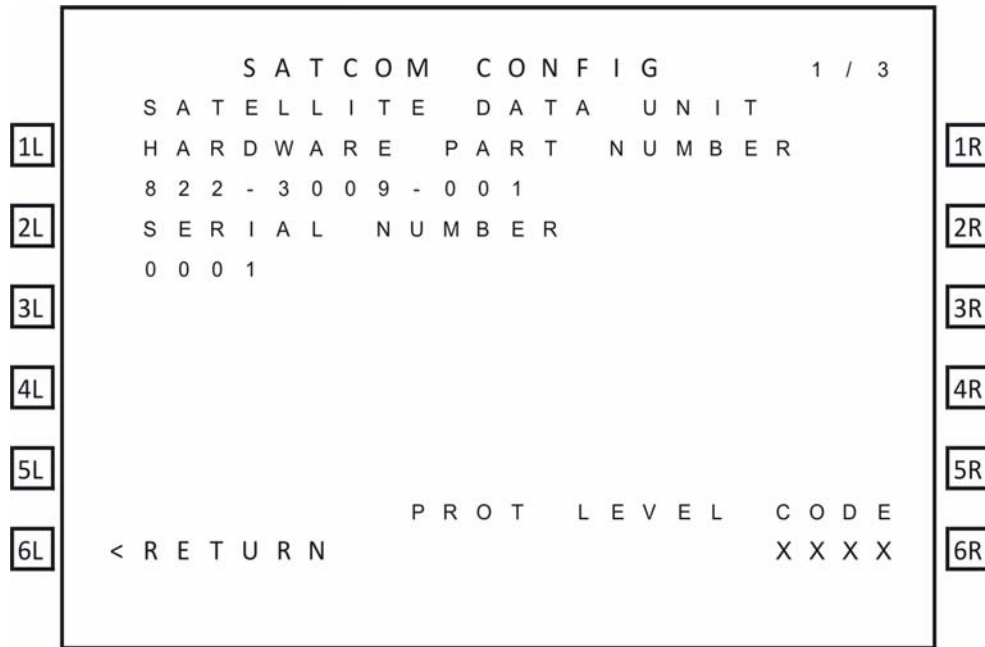

**Figure 2-6 SATCOM CONFIG 1 menu**

Table 2-5 describes the information available in the SATCOM CONFIG 1 menu.

**Table 2-5 SATCOM CONFIG 1 Menu**

Label	Description
Hardware Part Number	Part number of the A781-200 SDU.
Serial Number	Serial number of the A781-200 SDU.
PROT Level Code	This code is displayed if the SATCOM CONFIG menu is accessed from the In-Flight menus. It allows access to the Maintenance Mode MCDU menus. Contact RCI Product Support for the PROT level code.

As shown in Figure 2-7, the SATCOM CONFIG 2 menu provides the software part numbers of the equipment in the A781-200 system.

**SYSTEM DESCRIPTION, INSTALLATION, AND MAINTENANCE MANUAL  
ARINC 781-200 SDU and SCM**

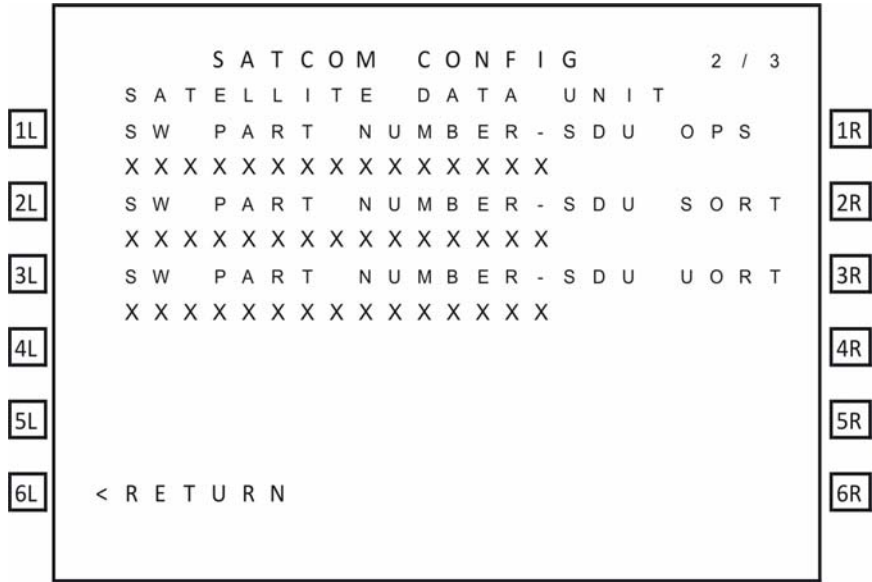

**Figure 2-7 SATCOM CONFIG 2 menu**

Table 2-6 describes the information available in the SATCOM CONFIG 2 menu.

**Table 2-6 SATCOM CONFIG 2 Menu**

Label	Description
SW Part Number SDU OPS	Software part number of the operational software in the A781-200 SDU.
SW Part Number SDU SORT	Software part number of the Secure ORT.
SW Part Number SDU UORT	Software part number of the User ORT.

As shown in Figure 2-8, the SATCOM CONFIG 3 menu provides the software and hardware part numbers of the antenna in the A781-200 system.



```

                S A T C O M   C O N F I G           3 / 3
S A T C O M   A N T E N N A
1L  L R U   P A R T   N U M B E R                 1R
    X X X X X X X X X X X X X X X X
2L  S E R I A L   N U M B E R                   2R
    0 0 0 1
3L  S O F T W A R E   A P P   N A M E           3R
    X X X X X X X X X X X X X X X X
4L  S W   P A R T   N U M B E R - A N T         4R
    X X X X X X X X X X X X X X X X
5L  O P T I O N S                             5R
    X X X X X X X X X X X X X X X X X X X X X X
6L  < R E T U R N                             6R
    
```

**Figure 2-8 SATCOM CONFIG 3 menu**

Table 2-7 describes the information available in the SATCOM CONFIG 3 menu.

**Table 2-7 SATCOM CONFIG 3 Menu**

Label	Description
SATCOM Antenna LRU Part Number	Hardware part number of the antenna in the A781-200 system.
Serial Number	Serial number of the antenna in the A781-200 system.
Software App Name	The reported software application name.
SW Part Number - ANT	Software part number of the antenna in the A781-200 system.
Options	The MCDU displays the optional information field of the configuration reporting message.

#### **4. Maintenance Mode**

The maintenance menus of the MCDU provide the same configuration and BITE information available in In-Flight mode, and provide access to the PIM test, audio configuration, and other options and parameters.

Maintenance mode includes a number of MCDU menus, as shown in Figure 2-9.

**SYSTEM DESCRIPTION, INSTALLATION, AND MAINTENANCE MANUAL  
ARINC 781-200 SDU and SCM**

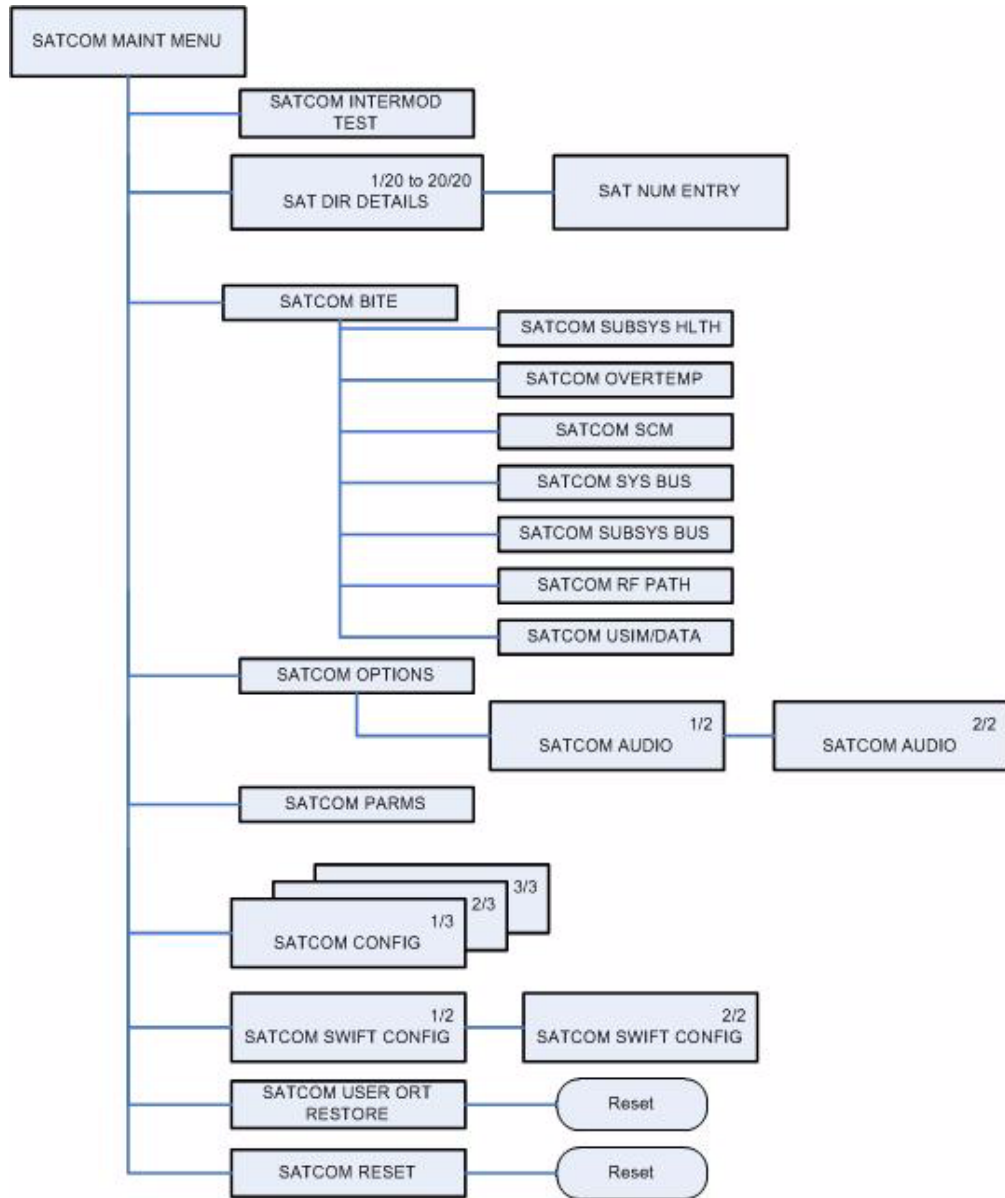

**Figure 2-9 Maintenance Mode MDCU Menu Structure**

**A. Accessing Maintenance Mode**

You can only access the MCDU maintenance menus when the plane is on the ground and classic services are logged off.

**SYSTEM DESCRIPTION, INSTALLATION, AND MAINTENANCE MANUAL  
ARINC 781-200 SDU and SCM**

To access the maintenance menus:

1. In the MCDU CONFIG 1/4 menu, type the protection level code in the scratchpad, and press the button next **PROT LEVEL CODE**.

NOTE: Contact RCI product support for the PROT level code.

The MCDU displays the MAINTENANCE ENTRY page.

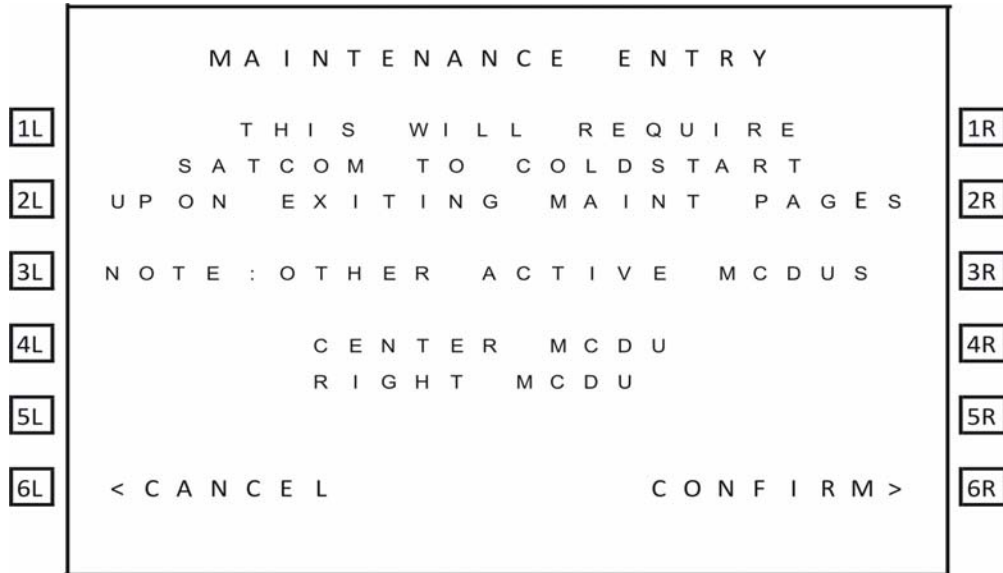

2. To enter Maintenance Mode, press the button next to **CONFIRM**.

The SATCOM MAINT MENU appears.

**SYSTEM DESCRIPTION, INSTALLATION, AND MAINTENANCE MANUAL**  
**ARINC 781-200 SDU and SCM**

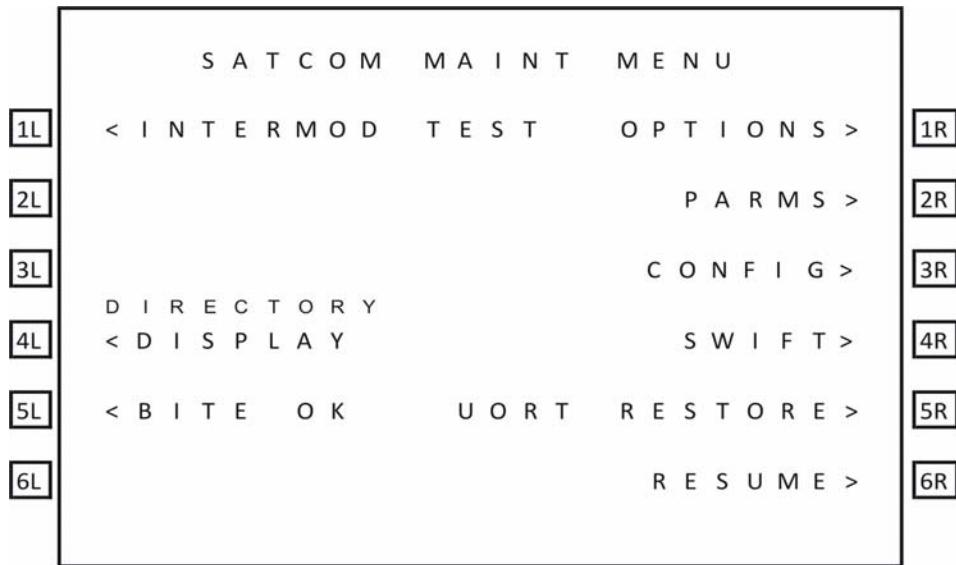

**B. Viewing BITE Information**

The BITE information available in maintenance mode is the same as the BITE information available in In-Flight mode. For information about the BITE menus, see "Viewing BITE Information" on page 2-15.

**C. Starting the Intermod Test**

For information and instructions about running the PIM test, see "Passive Intermodulation (PIM) Test" on page 3-8.

**D. Viewing Configuration**

The configuration menus available in maintenance mode are the same as the configuration menus in In-Flight mode. For information about these menus, see "System Part Numbers" on page 2-21.

**E. Viewing SATCOM Parameters**

As shown in Figure 2-10, the SATCOM PARMS menu provides information about logon, failover, and the channel cards.

**SYSTEM DESCRIPTION, INSTALLATION, AND MAINTENANCE MANUAL  
ARINC 781-200 SDU and SCM**

```

          S A T C O M   P A R M S
    L O G O N   M O D E
1L  < A U T O
                                     S D U / A N T
2L                                     2 . 0
    D D / M M / Y Y           C H A N   C A R D 1
3L  0 4 / 1 0 / 9 5           S B B * / S 6 4
    T I M E                   F A L L B A C K
4L  2 3 5 9                   E N A B L E D
5L                                     C H A N   C A R D 2
          C L S C   V O I C E / D A T A
6L  < R E T U R N
                                     S B B
    
```

**Figure 2-10 SATCOM PARMS**

Table 2-8 describes the information available in the SATCOM PARMS menu.

**Table 2-8 SATCOM PARMS Menu**

Label	Description
LOGON MODE	AUTO or MANUAL
DD/MM/YY	Current date
TIME	Current time
SDU/ANT	Estimated loss between the SDU and antenna
CHAN CARD1	Default data mode of operation in ORT.
FAILOVER	Disabled—SDI operates in SBB mode.
CHAN CARD2	Service and domain selection ORT parameter—CLSCVOICE/DATA

**F. Viewing SATCOM Options**

As shown in Figure 2-11, the SATCOM OPTIONS menu provides information about audio and phone operation.

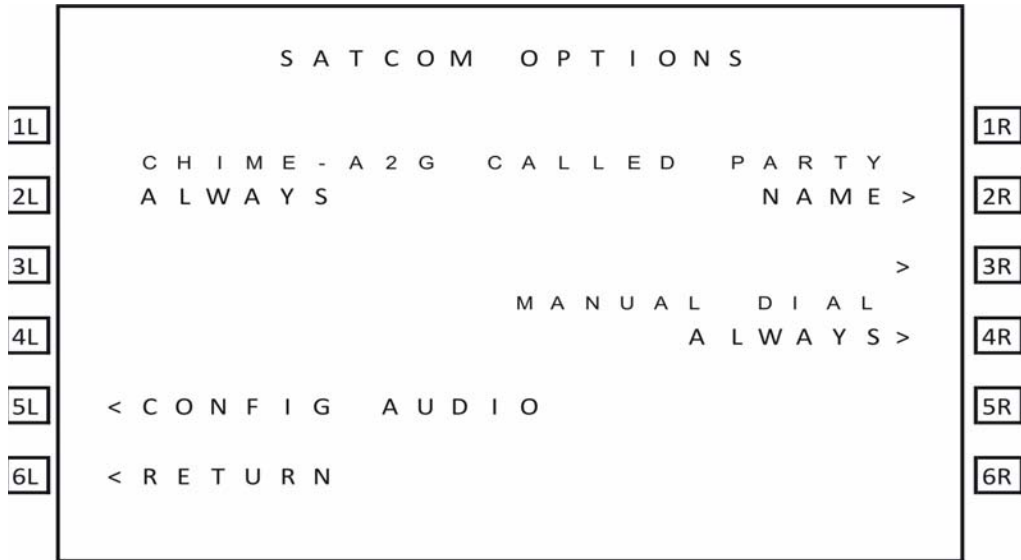

**Figure 2-11 SATCOM OPTIONS**

Table 2-9 describes the information available in the SATCOM OPTIONS menu.

**Table 2-9 SATCOM OPTIONS Menu**

Label	Description
CHIME-A2G	Value of the CHIME A@G ORT parameter.
CALLED PARTY	Display mode selection for call placement.
MANUAL DIAL	Current state of the scratchpad number entry control.

**G. Configuring Audio Options**

As shown in Figure 2-12 and Figure 2-13, the SATCOM CONFIG AUDIO menu provides information and settings for cockpit phone operation.

**SYSTEM DESCRIPTION, INSTALLATION, AND MAINTENANCE MANUAL  
ARINC 781-200 SDU and SCM**



**Figure 2-12 CONFIG AUDIO 1/2**

Table 2-10 describes the information available in the SATCOM CONFIG AUDIO 1 menu.

**Table 2-10 SATCOM CONFIG AUDIO 1 Menu**

Label	Description
AUDIO LINE	Switch between 4-wire 1 and 4-wire 2.
SPEAKER	Headset speaker level—0 to 100.
MICROPHONE	Microphone level—0 to 100.
SIDETONE	Sidetone level—0 to 100.
NOISE	Headset speaker noise level—0 to 100.

**SYSTEM DESCRIPTION, INSTALLATION, AND MAINTENANCE MANUAL  
ARINC 781-200 SDU and SCM**

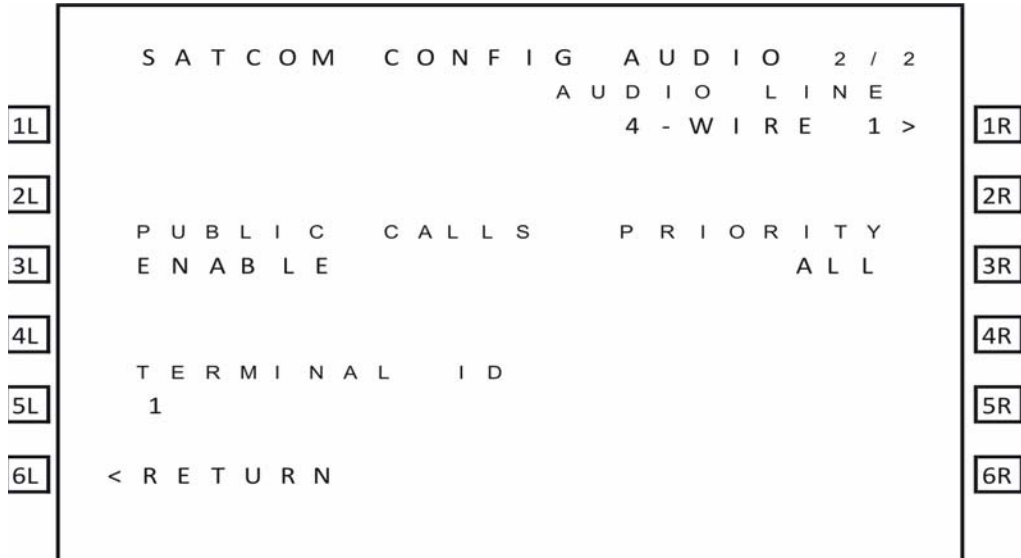

**Figure 2-13 CONFIG AUDIO 2/2**

Table 2-11 describes the information available in the SATCOM CONFIG AUDIO 2 menu.

**Table 2-11 SATCOM CONFIG AUDIO 2 Menu**

Label	Description
AUDIO LINE	Switch between 4-wire 1 and 4-wire 2.
PUBLIC CALLS	Displays the value of the Ground Initiated Public Call Routing ORT parameter. This parameter enables the placing and acceptance of public calls via the analog audio lines.
TERMINAL ID	The terminal ID for the selected audio line interface.
PRIORITY	The priority of calls allowed via the selected audio interface. The possible values are: <ul style="list-style-type: none"> <li>• COCKPIT</li> <li>• PUBLIC</li> <li>• ALL</li> </ul>



# INSTALLATION

This section describes the procedures required to install the A781-200 system (SDU and SCM) on an aircraft, including the following sections:

- Advisories
- Pre-Installation Inspection
- Installation Procedure
- Connection Details
- Owners Requirements Table (ORT)
- Passive Intermodulation (PIM) Test
- Installation and Engineering Drawings

## 1. Advisories

Before performing any installation procedures, read the safety advisories listed in the Introduction on page INTRO-4 of this manual.

## 2. Pre-Installation Inspection

Before installing any A781-200 system, conduct a pre-installation inspection of all parts to make sure that no damage occurred during shipping.

### A. Unpacking and Inspecting Equipment

- Unpack the A781-200 equipment from the shipping containers.
- Verify that the part number displayed on the shipping box and equipment component matches the model and part number ordered. If components are missing from the shipment, contact the supplier immediately and report the problem.
- Visually inspect the A781-200 equipment for any shipping damage. If any shipping damage has occurred, contact the shipping carrier immediately and report the problem.
- Check the A781-200 equipment connectors for corrosion and damage. If damage is noted, do not apply power to the equipment. Contact the supplier immediately to report the problem.

### B. Cabling Notes

Before proceeding with the installation of the A781-200 system, read all cabling notes provided on the Interconnection and Contact Assignment drawings on page 3-19.

### 3. Installation Procedure

Only authorized technical personnel, trained in general aviation workmanship, that have a basic understanding of SATCOM systems should proceed with the following procedure. Before performing any installation procedures, read the safety advisories listed in "Advisories" on page 3-1 of this manual.

**CAUTION:** THE ARINC 781-200 SYSTEM REQUIRES CONDITIONED AIR PER ARINC781. SEE NOTE 4 OF FIGURE 3-3 ON PAGE 3-11.

1. Install the SDU in a 6 MCU tray as per ARINC 600. The minimum clearance between the SDU and any other equipment installed above it shall be no less than 0.5 inches.
2. Install the SCM in any orientation. Refer to Table 1-2 on page 1-5 for the SCM mounting specification.
  - There are no clearance requirements for the SCM.
3. Connect the SCM to the SDU. The SDU supports one RS-422 interface for interconnect to the SCM.
4. Connect the SDU to the antenna subsystem. The SDU supports ARINC 429 communication to and from the antenna subsystem.
5. Connect the SDU to the MCDU(s). The SDU supports three ARINC 429 receive interfaces and one ARINC 429 transmit interface for interconnect to the flight deck MCDU(s).

### 4. Connection Details

#### A. SDU

The SDU uses two external interface connectors:

- Rear Connector—a low insertion force, size 2 shell receptacle accommodating coaxial and signal interconnections in the top plug insert, QuadraX and signal connections in the middle plug insert, and coaxial and power interconnections in the bottom plug insert. Pin assignments are compliant with ARINC Characteristic 781 with top plug and middle plug deviations as shown in Table 3-1.
- Front Connector—an RJ45 and 9S DSUB connector providing 10BT Ethernet interfaces and an RS-232 maintenance interface. Pin assignments are shown in Table 3-2. The front connector is behind a maintenance cover. This connector provides access to maintenance and troubleshooting information when the SDU is not in normal operation.

**Table 3-1 SDU Rear Connector Pin Deviations**

Pin Number	A781	Deviation
<b>Top Plug Insert Pin Deviations</b>		
TP01A	ATE pin 1	Router Processor Maintenance TXD
TP01B	ATE pin 2	Router Processor Maintenance RXD

**SYSTEM DESCRIPTION, INSTALLATION, AND MAINTENANCE MANUAL  
ARINC 781-200 SDU and SCM**

**Table 3-1 SDU Rear Connector Pin Deviations**

<b>Pin Number</b>	<b>A781</b>	<b>Deviation</b>
TP01C	ATE pin 3	Router Processor & Data I/O Processor Maintenance GND
TP01D	ATE pin 4	Data I/O Processor Maintenance TXD
TP01E	ATE pin 5	Data I/O Processor Maintenance RXD
TP01F	ATE pin 6	CC1 Processors #1 & #2 Maintenance GND
TP01G	ATE pin 7	CC1 Processor #1 Maintenance TXD
TP01H	ATE pin 8	CC1 Processor #1 Maintenance RXD
TP01J	ATE pin 9	CC1 Processor #2 Maintenance TXD
TP01K	ATE pin 10	CC1 Processor #2 Maintenance RXD
TP02D	ATE pin 14	Voice Processor Maintenance TXD
TP02E	ATE pin 15	Voice Processor Maintenance RXD
TP02F	ATE pin 16	CC2 Processors #1 & #2 Maintenance GND
TP02G	ATE pin 17	CC2 Processor #1 Maintenance TXD
TP02H	ATE pin 18	CC2 Processor #1 Maintenance RXD
TP02J	ATE pin 19	CC2 Processor #2 Maintenance TXD
TP02K	ATE pin 20	CC2 Processor #2 Maintenance RXD
TP03C	Empty Cavity	SPARE
TP04C	Empty Cavity	SPARE
TP05A	Empty Cavity	SPARE
TP05B	Empty Cavity	SPARE
TP05C	Empty Cavity	SPARE
TP06C	Empty Cavity	SPARE
TP07C	Empty Cavity	SPARE
<b>Middle Plug Insert Pin Deviations</b>		

**Table 3-1 SDU Rear Connector Pin Deviations**

<b>Pin Number</b>	<b>A781</b>	<b>Deviation</b>
MP08E	Data Loader Link A	Use by 615A Data Loader (Ethernet)
Note 1: Wiring harness to SCM provides 2 physical connections to each pin		

Figure 3-1 shows the top plug pin deviations outlined in gray.

**SYSTEM DESCRIPTION, INSTALLATION, AND MAINTENANCE MANUAL  
ARINC 781-200 SDU and SCM**

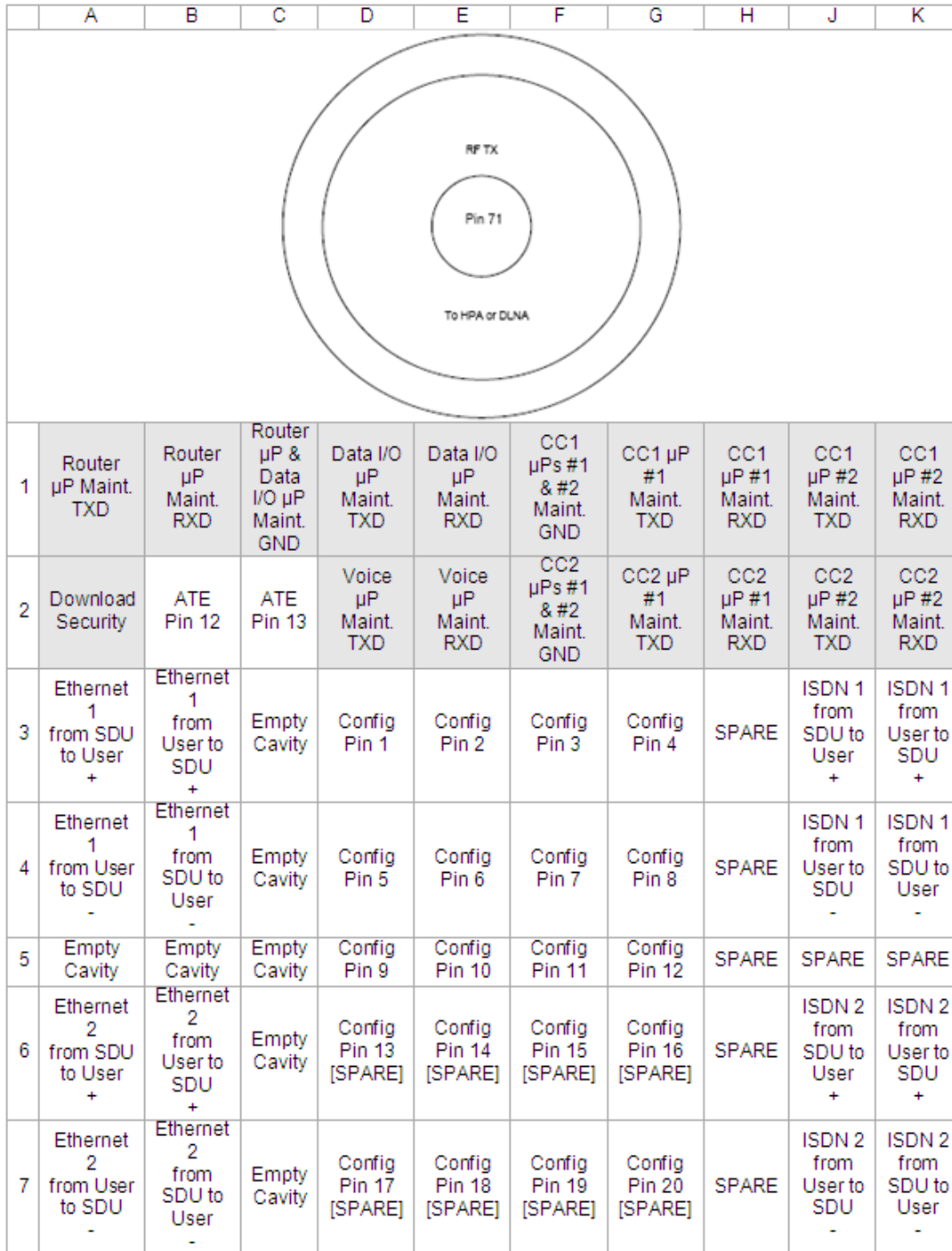

**Figure 3-1 Top Plug Pin Deviations**

Figure 3-2 shows the mid plug pin deviations outlined in gray

**SYSTEM DESCRIPTION, INSTALLATION, AND MAINTENANCE MANUAL  
ARINC 781-200 SDU and SCM**

	A	B	C	D	E	F	G	H	J	K
1	Data from MCDU 1 A	Data from MCDU 1 B	Call Place/End Discrete Input 1	SCM Pwr +8 to +15V	Multi-Control Output A	Multi-Control Output B	Resv Ext Reset Discrete Input	Call Place/End Discrete Input 2	Data from MCDU 2 A	Data from MCDU 2 B
2	Data from Primary IRS/GNSS A	Data from Primary IRS/GNSS B	Cockpit Voice Chime Signal Contact 1	SCM Pwr Return 0V	BITE Input From HPA A	BITE Input From HPA B	Rsvd Mfr-Specific 0-28V Discrete Output	Cockpit Voice Chime Signal Contact 2	Data from Secondary IRS A	Data from Secondary IRS B
3	Data from CMU 1 A	Data from CMU 1 B	Cockpit Voice Call Light Output 1	SDU Data to SCM A	Spare Discrete Output	Spare Discrete Input	SPARE	Cockpit Voice Call Light Output 2	Data from CMU 2 A	Data from CMU 2 B
4	Cockpit Audio Input 1 High	Cockpit Audio Input 1 Low	Cockpit Voice MIC On Input 1	SDU Data to SCM B	Spare Discrete Output	Spare Discrete Input	SPARE	Cockpit Voice MIC On Input 2	Cockpit Audio Input 2 High	Cockpit Audio Input 2 Low
5	Cockpit Audio Output 1 High	Cockpit Audio Output 1 Low	Cockpit Voice Go Ahead Chime Reset 1	SCM Data to SDU A	Spare Discrete Output	Spare Discrete Input	Spare ARINC 429 Output A	Spare ARINC 429 Output B	Cockpit Audio Output 2 High	Cockpit Audio Output 2 Low
6	Spare Discrete Input	Spare Discrete Input	Spare Discrete Input	SCM Data to SDU B	Ethernet 5 10 Ethernet T (Spare) from SDU to User+	Ethernet 5 10 Ethernet T (Spare) from SDU to User-	Spare ARINC 429 Input A	Spare ARINC 429 Input B	Data From GNSS to SDU A	Data From GNSS to SDU B
7	AES ID Input A	AES ID Input B	Spare Discrete Input	WOW Input 1	Ethernet 5 10 Ethernet T (Spare) from User to SDU+	Ethernet 5 10 Ethernet T (Spare) from User to SDU-	Spare ARINC 429 Output A	Spare ARINC 429 Output B	Data to CMU 1&2 A	Data to CMU 1&2 B
8	Data from CFDS A	Data from CFDS B	BITE Input Top/Port BSU/Ant A	BITE Input Top/Port BSU/Ant B	Data Loader Link A	TX Mute Input	BITE Input STBD BSU A	BITE Input STBD BSU B	Data to CFDS A	Data to CFDS B
9	From Airborne Data Loader A	From Airborne Data Loader B	Crosstalk From Other SDU A	Crosstalk From Other SDU B	Dual System Select Discrete I/O	Dual System Disable Discrete I/O	Crosstalk To Other SDU A	Crosstalk To Other SDU B	To Airborne Data Loader A	To Airborne Data Loader B
10	Data from MCDU 3 A	Data from MCDU 3 B	Port BSU HPA Mute Input A	Port BSU HPA Mute Input B	LGA LNA On/Off Control	BITE From LGA LNA	STBD BSU HPA Mute Input A	STBD BSU HPA Mute Input B	Data to MCDU 1,2,3 A	Data to MCDU 1,2,3 B
11	POTS 1 A	POTS 1 B	Cabin CEPT-E1 Data Output A	Cabin CEPT-E1 Data Output B	Service Availability Discretes 1	Service Availability Discretes 2	Cabin CEPT-E1 Data Input A	Cabin CEPT-E1 Data Input B	POTS 2 A	POTS 2 B
12					Service Availability Discretes 3	Service Availability Discretes 4				
13					Service Availability Discretes 5	Service Availability Discretes 6				
14					Service Availability Discretes 7	Service Availability Discretes 8				
15					Service Availability Discretes 9	Service Availability Discretes 10				

**Figure 3-2 Mid Plug Pin Deviations**

**SYSTEM DESCRIPTION, INSTALLATION, AND MAINTENANCE MANUAL  
ARINC 781-200 SDU and SCM**

**Table 3-2 SDU Front Connector DSUB and RJ45 Pin Assignment**

<b>9S DSUB Pin Number</b>	<b>Description</b>	<b>RJ45 Pin Number</b>	<b>Description</b>
1	NC	1	RX+
2	TX	2	RX-
3	RX	3	TX+
4	NC	4	NC
5	GND	5	NC
6	NC	6	TX-
7	NC	7	NC
8	NC	8	NC
9	NC		

**B. SCM**

The SCM uses a 15 pin D-type male connector and locking screws. Pin assignments are compliant with ARINC Characteristic 781 and shown in Table 3-3.

**Table 3-3 SCM D-Type Connector Pin Assignment**

<b>Pin Number</b>	<b>Description</b>
1	Data to SDU A (RS422)
2	Data to SDU B (RS422)
3	Data from SDU A (RS422)
4	Data from SDU B (RS422)
5	Reserved - RS232 Gnd (used for shop loading)
6	Spare
7	Chassis Ground
8	Power Input +8 V to +15 V
9	Reserved - Enable RS232 (used for shop loading)
10	Reserved - 0 V strap output (used for shop loading)
11	Spare
12	Reserved - RS232 Tx (used for shop loading)
13	Reserved - RS232 Rx (used for shop loading)
14	Spare

Table 3-3 SCM D-Type Connector Pin Assignment (Continued)

Pin Number	Description
15	Power Return 0 V

## 5. Owners Requirements Table (ORT)

### A. ORT Overview

The A781-200 system includes a secure and user ORT. Secure ORT files must be certified for the aircraft type on which the equipment is installed. Items in user ORT files can be modified by individual customers and may be customized to an individual aircraft.

You can change secure ORT parameters only by uploading an ORT file. To obtain an ORT file, contact RCI Product Support.

The ORT file is loaded on to the SCM using an ARINC 615A data loader. You can only load ORT data when the aircraft is on the ground and the data load discrete is asserted. When the SDU boots, it compares the ORT file in its memory to that in the SCM. If the ORT files do not match, the SDU loads the file from the SCM into its memory.

Some user ORT parameters can be modified in the SDU ORT. You can reset the SDU ORT to the default values stored in the SCM in the maintenance menus.

For more information see the following Guides:

- MN-0000461, A781-200 User Ort User Guide
- MN-0000462, A781-200 Secure ORT User Guide
- MN-0000463, A781-200 ORT Application Install Manual

## 6. Passive Intermodulation (PIM) Test

This section describes the passive intermodulation (PIM) test. You must execute the PIM test after installation if the A781-200 SDU operates in SwiftBroadband mode.

### A. Overview

To meet Inmarsat requirements for SBB operation, the A781-200 SDU can test for passive intermodulation effects. The PIM test verifies that the transmit signal from the A781-200 SDU does not degrade or interfere with the receive signals as a result of PIM.

A781-200 SDU can only perform the PIM test when the aircraft is on the ground.

When the A781-200 SDU logs on to the SBB network, the network assigns the terminal two channels for PIM testing. These channels are not used by other terminals so that the A781-200 SDU can transmit the test frequencies without interfering with other satellite communication equipment or the Inmarsat satellite.

### B. PIM Requirements

In order to successfully perform the PIM test, the aircraft and the satellite communication system must meet the following requirements:



**SYSTEM DESCRIPTION, INSTALLATION, AND MAINTENANCE MANUAL  
ARINC 781-200 SDU and SCM**

- The A781-200 SDU must have successfully logged on to a satellite that is visible at the test location within the last 168 hours (7 days).
- The aircraft has to be outside the hangar and far away from the hangars and towers in order to obtain good results.
- The aircraft must be facing due north in the northern hemisphere, and due south in the southern hemisphere.

**C. PIM Test**

To run the PIM test you must be in maintenance mode. You can only access the MCDU maintenance menus when the plane is on the ground and classic services are logged off.

To start the PIM test:

1. In the MCDU CONFIG 1/4 menu, type the protection level code in the scratchpad, and press the button next **PROT LEVEL CODE**.

NOTE: Contact RCI product support for the PROT level code.

The SATCOM Maintenance Entry page appears.

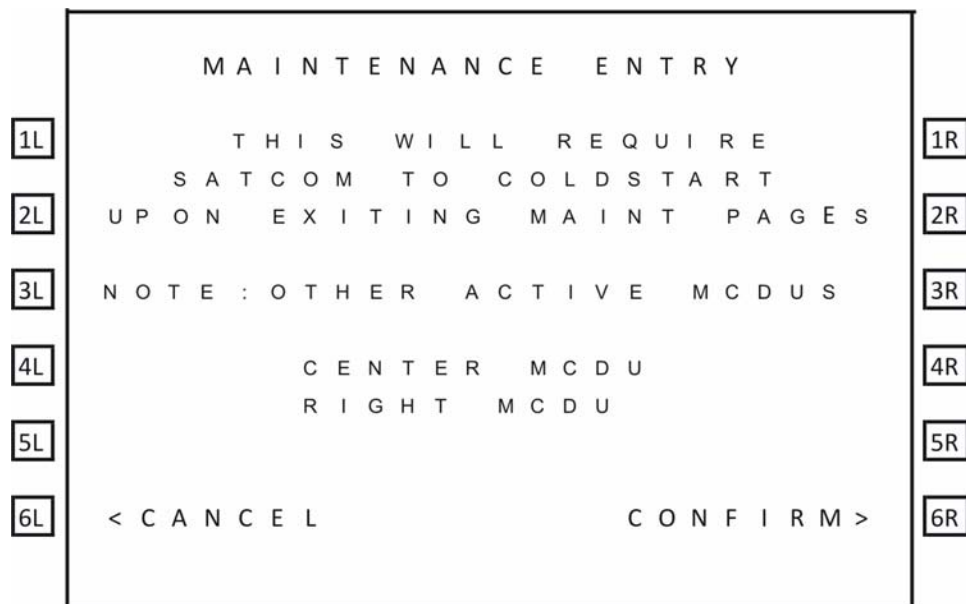

2. To enter maintenance mode, press the button next to **CONFIRM**.  
The MAINTENANCE MENU appears.
3. To start the PIM test, press the button next to **INTERMOD TEST**.  
The PIM test starts. The test takes about five minutes.

**D. PIM Test Results**

- (1) PIM Test Overall Status

At the end of the PIM test, the A781-200 SDU displays the test results on the MCDU screen.

**SYSTEM DESCRIPTION, INSTALLATION, AND MAINTENANCE MANUAL  
ARINC 781-200 SDU and SCM**

The MCDU displays the overall PIM status and results for each direction. If the overall status is PASS, the SDU can continue to use SBB services.

If the overall status is FAIL:

- Check the cable connections of the antenna and the SDU.
- Check the direction in which the test failed and verify that the antenna is not blocked in that direction—see "Directional PIM Test Results" on page 3-10.

(2) **Directional PIM Test Results**

The SDU performs the PIM test with the antenna pointing in different directions and displays the results of the test in each direction. If the overall status of the PIM test is FAIL, you can check the specific directions in which the test failed.

For each direction, the PIM test results provide:

- Overall Status—pass or fail.
- The direction coordinates.
- The signal degradation—the maximum value to pass the test is 3 dB.
- Possible interference—interference caused by environmental factors, not the SDU transmit frequencies. Interference indicates that the SDU received a signal in the receive band even when it wasn't transmitting, therefore an external signal may be interfering with communication in that direction.
- Signal and noise levels before and after the test—the SDU uses this information to check for possible interference.

## **7. Installation and Engineering Drawings**

This section contains the Outline and Installation diagrams, and Interconnection and Contact Assignment drawings for the SDU and SCM.

All foldout pages are odd-numbered and not-backed for print production purposes.

### **A. Outline and Installation Drawings**

The Outline and Installation drawings on pages 3–11 to 3–17 show the physical characteristics of the SDU and SCM, and provide installation data for the system.

### **B. System Interconnect Drawings**

System Interconnect drawings on pages 3–19 to 3–23 show the interconnection details for the SDU and SCM.

SYSTEM DESCRIPTION, INSTALLATION, AND MAINTENANCE MANUAL  
ARINC 781-200 SDU and SCM

NOTES:

1. THIS UNIT MEETS THE DIMENSIONAL REQUIREMENTS OF ARINC SPECIFICATION 781
2. MAXIMUM WEIGHT IS 11.36kg (25 LBS)
3.  INDICATES APPROXIMATE CENTER OF GRAVITY
4. COOLING AIR REQUIREMENTS PER ARINC 781:
  - FLOW RATE: 50kg/HOUR 40°C (MAX) AIR
  - PRESSURE DROP: 5 +/-3mm of WATER
5. FINISH:
  - METAL TREATMENT: CHEMICAL FILM PER MIL-DTL-5541 TYPE 11, CLASS 3
  - EXTERIOR FINISH: PRISM POWDER COAT PB134LT (POLYESTER POWDER, SATIN SANTEX BLACK)
6. POWER REQUIREMENT: 400 WATTS AT 115VAC (300-900Hz)

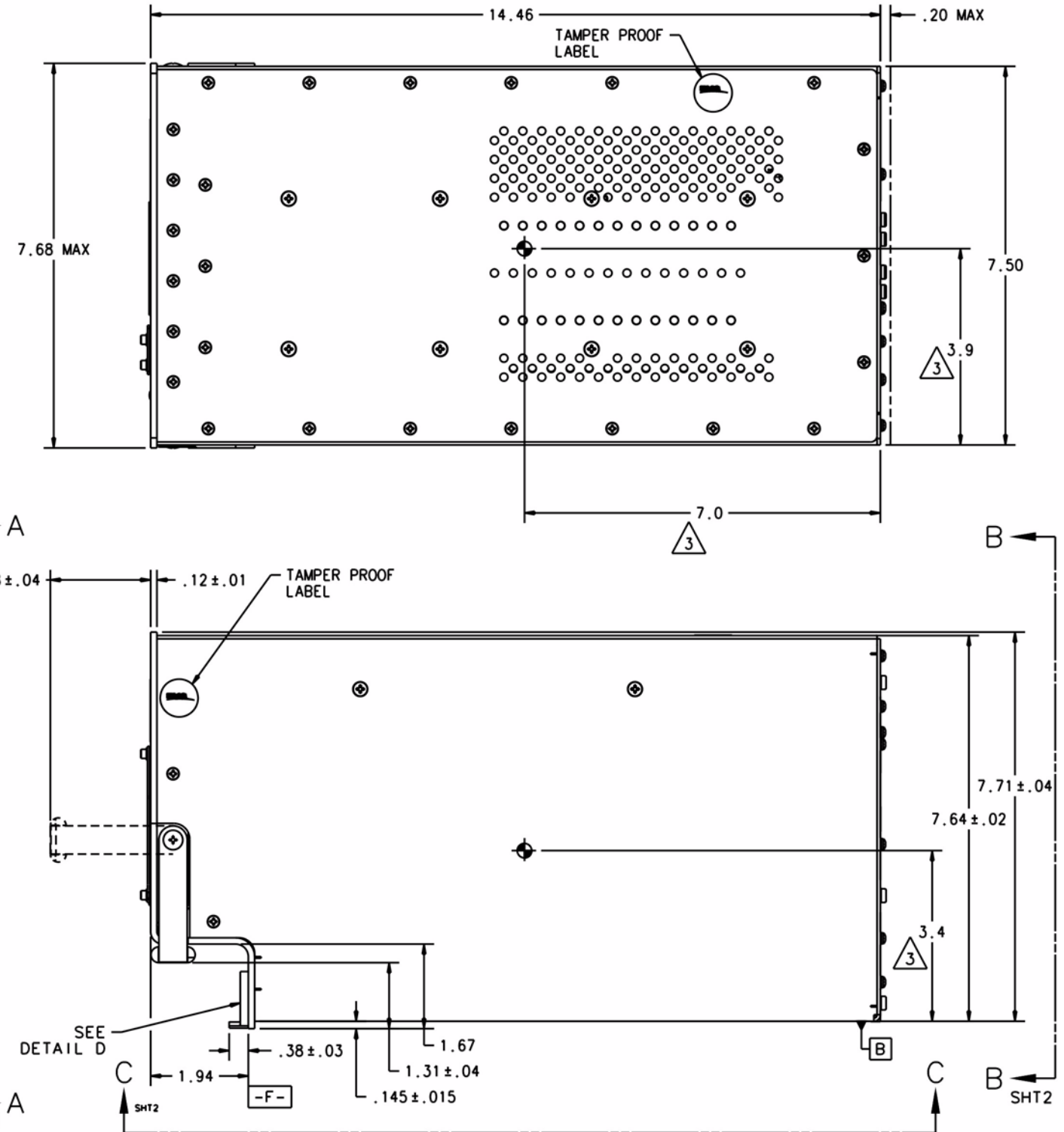
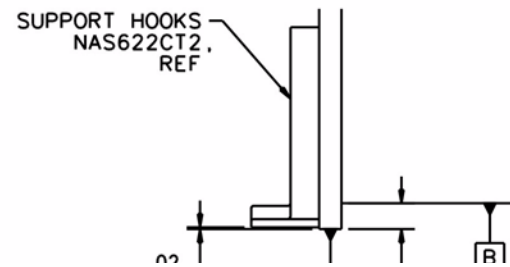
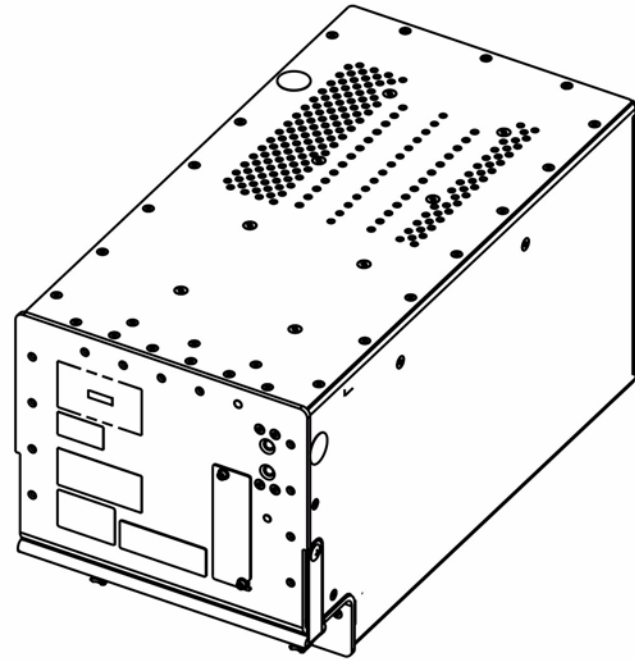
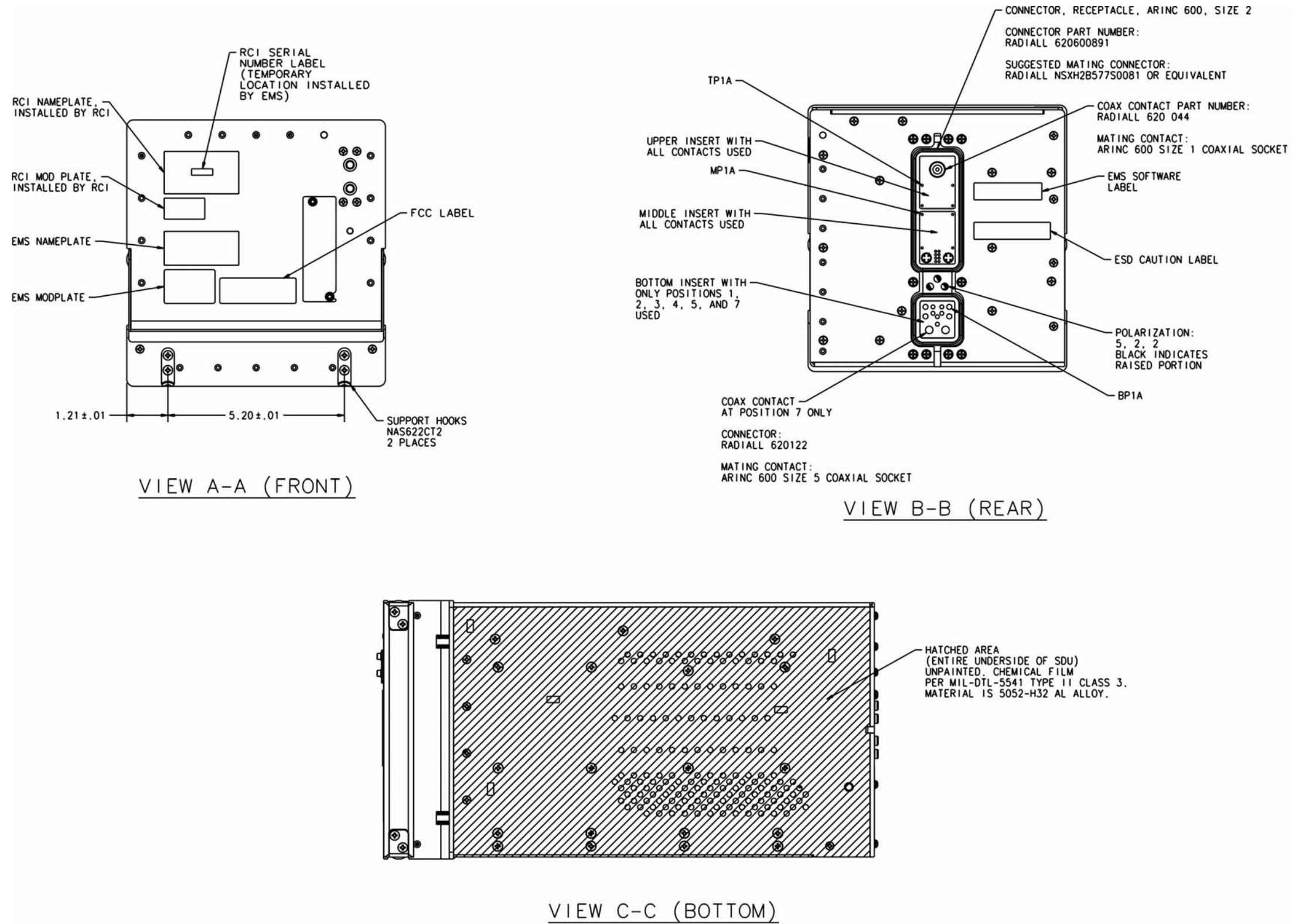

Figure 3-3 ARINC 781-200 SDU Outline and Installation Drawing, 1530-E-1100 Rev B00 (Sheet 1 of 2)

Blank Page

SYSTEM DESCRIPTION, INSTALLATION, AND MAINTENANCE MANUAL  
ARINC 781-200 SDU and SCM



Doc No 1530-E-1100  
REV B  
SH 2

Figure 3-4 ARINC 781-200 SDU Outline and Installation Drawing, 1530-E-1100 Rev B00 (Sheet 2 of 2)

Blank Page

SYSTEM DESCRIPTION, INSTALLATION, AND MAINTENANCE MANUAL  
ARINC 781-200 SDU and SCM

NOTES:

1. THIS UNIT MEETS THE DIMENSIONAL REQUIREMENTS OF ARINC SPECIFICATION 781.
2. MAXIMUM WEIGHT IS .45 kg (1 LB).
3.  INDICATES APPROXIMATE CENTER OF GRAVITY.
4. TORQUE REQUIREMENTS FOR MOUNTING SCREWS ARE 4.5-6.5 IN-LBS.
5. POWER REQUIREMENT: 12 WATTS MAX, 2.4 WATTS NOM AT 12VDC.
6. FINISH:  
-METAL TREATMENT: CHEMICAL FILM PER MIL-DTL-5541 TYPE II, CLASS 3  
-EXTERIOR FINISH: PRISM POWDER COAT PB134LT (POLYESTER POWDER, SATIN SANTEX BLACK)

TABLE 1: VARIANTS

ASSY PART NUMBER	DESCRIPTION
1530-A-1300-01	UNIT ASSY, A781-200 SCM SINGLE
1530-A-1300-02	UNIT ASSY, A781-200 SCM DUAL

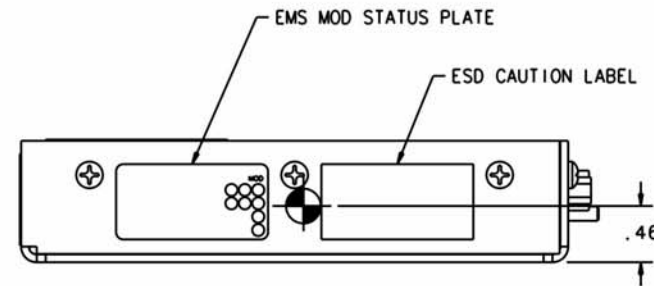
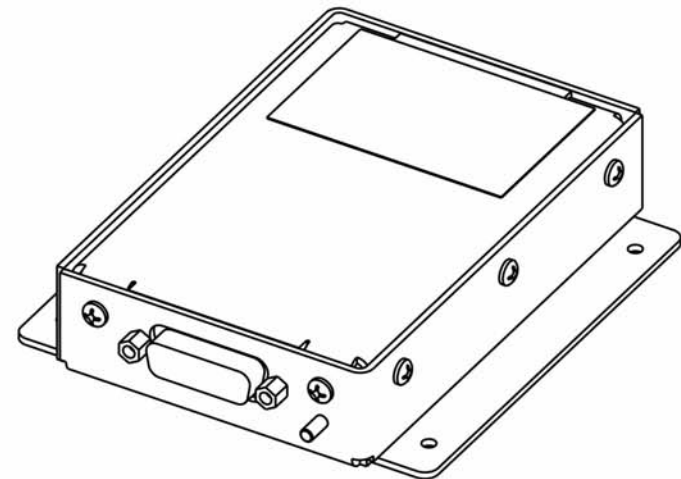
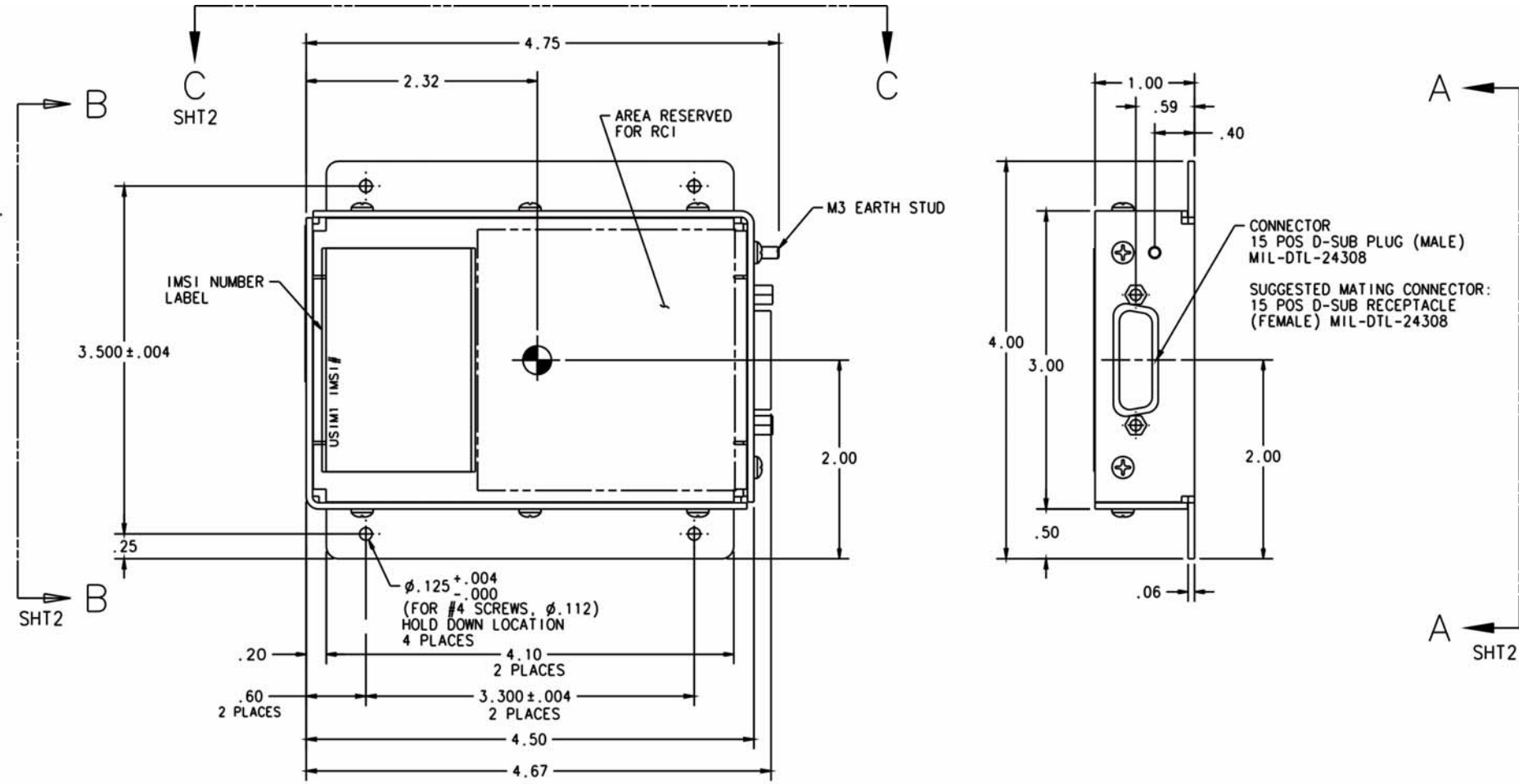

Figure 3-5 ARINC 781-200 SCM Outline and Installation Drawing, 1530-E-1300 Rev C00 (Sheet 1 of 2)

Dwg No 1530-E-1300-  
 REV C  
 SHT 1

Blank Page



SYSTEM DESCRIPTION, INSTALLATION, AND MAINTENANCE MANUAL  
ARINC 781-200 SDU and SCM

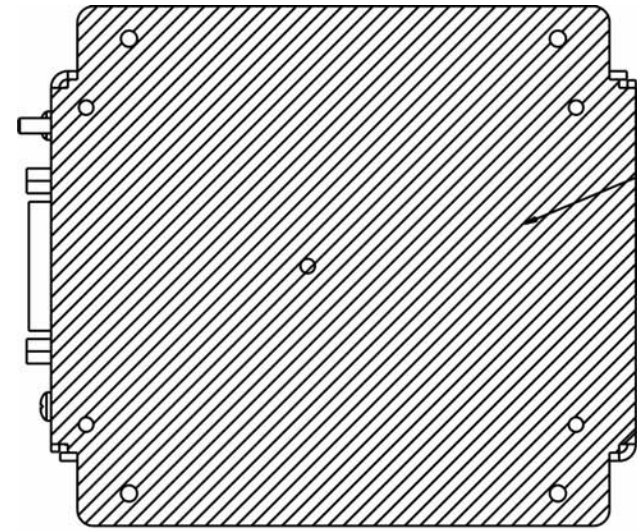

HATCHED AREA  
(ENTIRE UNDERSIDE OF UNIT)  
UNPAINTED, CHEMICAL FILM  
PER MIL-DTL-5541 TYPE II CLASS 3,  
MOUNTING SURFACE MATERIAL IS  
5052-H32 AL ALLOY

VIEW A-A (BOTTOM)

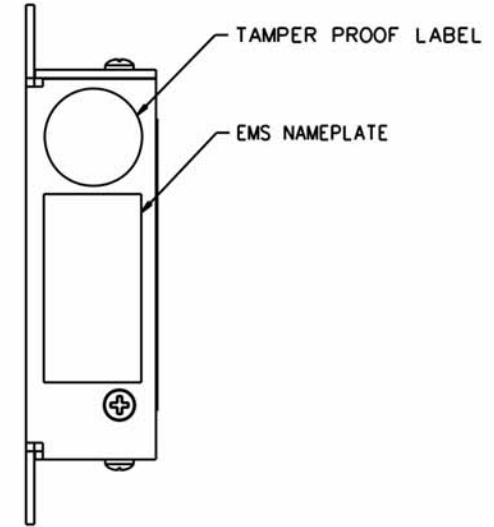

VIEW B-B

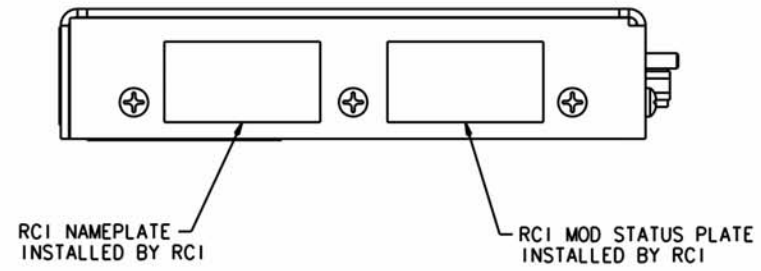

VIEW C-C

Doc No 1530-E-1300-  
REV C  
SHEET 2

Figure 3-6 ARINC 781-200 SCM Outline and Installation Drawing, 1530-E-1300 Rev C00 (Sheet 2 of 2)

Blank Page

SYSTEM DESCRIPTION, INSTALLATION, AND MAINTENANCE MANUAL  
ARINC 781-200 SDU and SCM

NOTES:

- ① TX MAX LOSS: 2.5dB TO ANTENNA.
- ② RX LOSS: 6-25dB.
- ③ CABLE BETWEEN SDU AND SCM TO BE LESS THAN 10 METERS.  
WIRE USED TO ROUTE SCM POWER (SCM PWR) MUST BE 22 AWG MINIMUM.
4. SEE SHEET 2 FOR INTERCONNECTION DIAGRAM.
- ⑤ IF THE NUMBER OF OTHER CONFIGURATION PINS IS EVEN, THEN STRAP CONFIGURATION  
PIN 3 (TP3F) TO SERVICE AVAILABILITY DISCRETE 1 (MP11E).
- ⑥ ANTENNA GAIN: 13.5dB MINIMUM.
7. P † DENOTES TWISTED PAIR

Doc No	1530-B-1001	REV	SMT
		C	1

Figure 3-7 ARINC 781-200 System Interconnect Drawing, 1530-B-1001 Rev C00 (Sheet 1 of 3)

Blank Page

SYSTEM DESCRIPTION, INSTALLATION, AND MAINTENANCE MANUAL  
ARINC 781-200 SDU and SCM

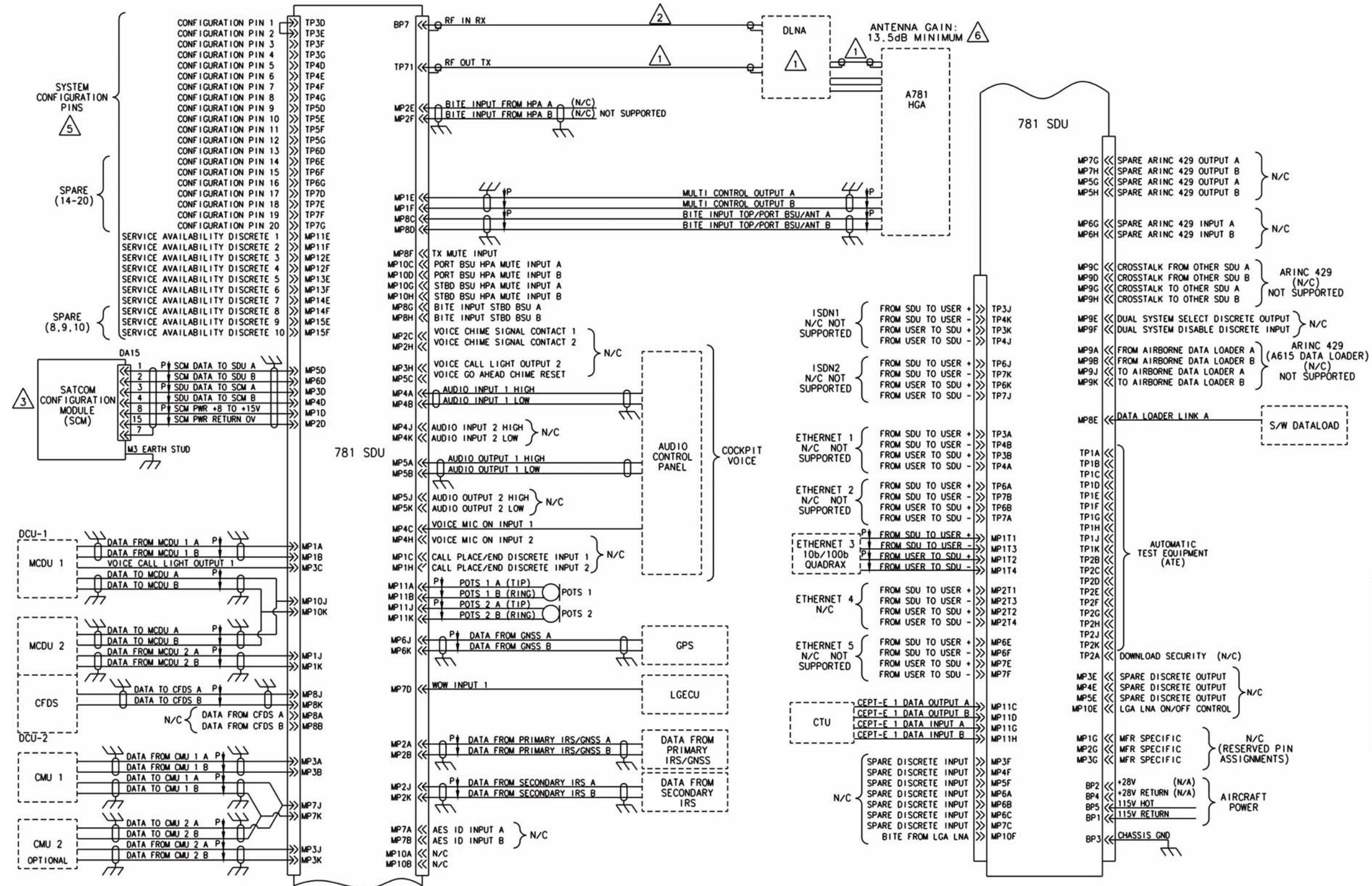

Figure 3-8 ARINC 781-200 System Interconnect Drawing, 1530-B-1001 Rev C00 (Sheet 2 of 3)

Blank Page

**SYSTEM DESCRIPTION, INSTALLATION, AND MAINTENANCE MANUAL  
ARINC 781-200 SDU and SCM**

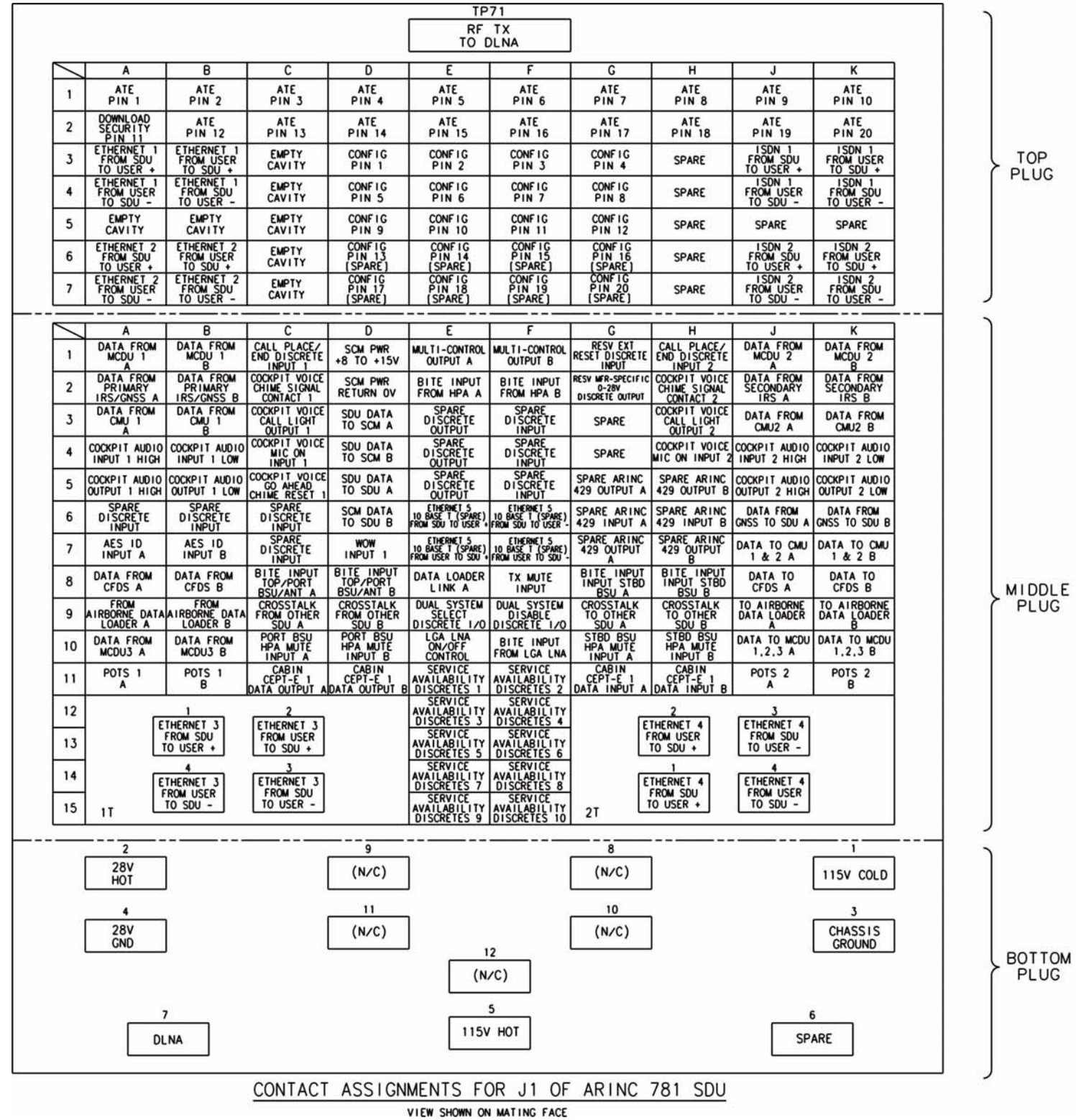

Figure 3-9 ARINC 781-200 System Interconnect Drawing, 1530-B-1001 Rev C00 (Sheet 3 of 3)

Blank Page



## TEST AND FAULT ISOLATION

This section provides test procedures to determine the operational readiness of SDU units.

There are no operational test procedures defined for the SCM. SCM health is determined by accessing the SDU BITE information.

If the A781-200 equipment passes all tests in this section but does not function according to the installation requirements, the fault may be with equipment or wiring outside the A781-200 system.

This section includes:

- Operational and Diagnostic Testing
- Troubleshooting and Fault Isolation
- Adjustment/Alignment Procedures
- Modification History

NOTE: Depending on the version of software installed, the MPU menus described may differ from those shown as examples in this manual.

### 1. Operational and Diagnostic Testing

This section includes the following sections:

- General
- Test and Fault Isolation Equipment Requirements
- SDU Maintenance Port Utility (MPU)
- Operational and Diagnostic Test Procedures

#### A. General

The A781-200 system requires testing for one of the following reasons:

- To verify the operational readiness of the system after installation on an aircraft
- To verify that a fault exists and produce system reports for troubleshooting purposes
- To verify the operational readiness of repaired LRUs after re-installation on an aircraft

This section includes test and fault isolation procedures for the A781-200 system. All test and load procedures require the A781-200 SDU MPU, which is accessed by connecting to the maintenance port of the SDU.

#### B. Test and Fault Isolation Equipment Requirements

Table 4-1 lists the equipment required to access the SDU Maintenance Port Utility (MPU) and perform operational and diagnostic testing on the SDU.

**Table 4-1 List of Required Test Equipment**

Item	Equipment	Specification	Quantity
Computer	Standard	PC running VT-100 terminal emulator such as HyperTerminal and equipped with an RS-232 port.	1
VT-100 terminal emulation program	HyperTerminal®, ProComm Plus®, or equivalent	Serial communication program using an RS-232 port	1
Cable	RS-232 cable	Maximum length 25 feet	1

**C. SDU Maintenance Port Utility (MPU)**

This section describes the SDU MPU and provides the connection and cabling details required to access and use the program.

(1) Connecting to the MPU

The MPU provides a system interface for fault isolation and diagnostic procedures.

To use the SDU MPU, connect an RS-232, VT-100 terminal (computer operating a terminal emulation program) to the RS-232 maintenance port interface of the SDU.

The maintenance port on the front panel of the SDU provides a direct connection to the MPU using a DB9 connector.

Figure 4-1 provides cabling details for the SDU maintenance port.

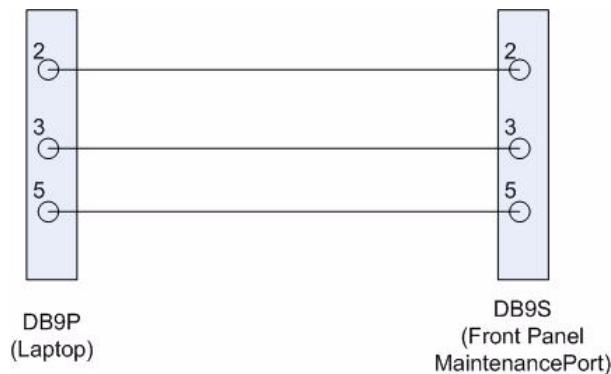

**Figure 4-1 Maintenance Cable**

(a) Interface Requirements

A standard VT-100 compatible terminal running an emulator program (such as HyperTerminal, ProComm Plus, or similar) provides the user interface to the SDU MPU. The RS-232 terminal connection settings for SDU maintenance ports are listed in Table 4-2.

**Table 4-2 Maintenance Port Connection Settings**

<b>Parameter</b>	<b>Setting</b>
Character Format	ASCII
Baud Rate	19200 bps
No. of bits	8
Parity	None
Stop bits	1
Flow Control	None

(2) Using the SDU MPU

This section describes the basic procedures for using and navigating the SDU MPU.

**NOTE:** There are various levels of access to the MPU. Each level is protected by a different password. This section describes the MPU functions available using the Level 1 password.

(a) Entering Passwords

You can enter the password any time after the SDU boots.

- To access Level 1 functions, type **menu**.

**NOTE:** The password does not appear on the screen when you type it.

(b) Navigating the SDU MPU

- To scroll through the available menus, press CTRL+N.
- To go to the previous menu, press CTRL+O.
- To refresh the menu screen or exit from a Reports Menu, press ESC.

(c) Selecting Menu Items

- To enable test or data entry functions, press the letter associated with the menu items.

(d) Selecting Reports

The reports available through the MPU enable users to view information about the configuration and status of the SDU. This information is used to troubleshoot the communication system on the aircraft.

To access reports:

1. In the MPU, press EQUAL SIGN (=).

A list of reports appears. Active reports show as toggled on. Inactive reports show as toggled off.

2. To activate a report, type the report number, and then press ENTER.

**NOTE:** Multiple reports can be activated at the same time; type and enter each report number separately.

3. To turn off individual, active reports, type the report number you want to toggle off, and then press ENTER.

**SYSTEM DESCRIPTION, INSTALLATION, AND MAINTENANCE MANUAL  
ARINC 781-200 SDU and SCM**

4. To turn off all active reports, press EQUAL SIGN (=), and then press X.

(3) Menu Item Descriptions

This section provides a brief description of the Level 1, MPU menu items used for test and fault isolation procedures.

In active SDUs, menu screens display the firmware version.

**NOTE:** Depending on the version of software installed and the system configuration, the menu and reports available to users may differ slightly from the reports described in this document.

(a) Menu 1

Table 4-3 describes the items available in Menu 1.

**Table 4-3 Menu 1 Item Descriptions**

<b>Menu Item</b>	<b>Description</b>
Y: explain error status	Reports error status when failure LED is illuminated. Displays OK if no error exists.
F: print equipment stats	Prints a list of the current equipment statistics, including temperature, number of power-ups, hours of operation, time since power-up, and processor usage.

(b) Menu 2

Table 4-4 describes the items available in Menu 2.

**Table 4-4 Menu 2 Item Descriptions**

<b>Menu Item</b>	<b>Description</b>
L: re-enter logon password	Permits a user to enter a new access level password without having to reboot the SDU.
Z: reset A781 SDU	Enables a complete, soft reset of the SDU; once reset, the menu access password must be re-entered.
H: query SDU-FMPA cable loss	Initiates the cable loss determined in auto-calibration.
V: get firmware versions	Displays the kernel and application software versions for the Control Processor, Data I/O Processor, Channel Cards
C: query loss of cooling mode	Indicates if loss of cooling mode is active or inactive.

(c) Menu 3

Table 4-5 describes the items available in Menu 3.

**Table 4-5 Menu 3 Item Descriptions**

Menu Item	Description
F: list call log	Lists Classic call logs for the following events: <ul style="list-style-type: none"> <li>• Successful Aero Log-on</li> <li>• Air-to-ground calls accepted by the SDU</li> <li>• Ground-to-air calls accepted by the SDU</li> </ul> Lists SBB call logs for the following events: <ul style="list-style-type: none"> <li>• Attachment or modification of attachment, including change of beam ID</li> <li>• Creation or deletion of primary or secondary contexts</li> </ul>
O: list DIO ORT	Lists of ORT items destined for the Data Processor in human readable form.
Y: verify CP ORT	Verifies if file name of the internal copies of the Secure and User ORT are valid or corrupted.
G: clear call log	Clears the call log after a confirmation.
H: list CP ORT	Lists ORT settings and how they were configured (either by default or through the maintenance port, or via SCM ORT files). "Set by maintenance port" indicates that the ORT parameter is set by the maintenance port.

**D. Operational and Diagnostic Test Procedures**

You can perform all test procedures presented in this section to test the total operational status of the A781-200 system. You can conduct these operational tests for all equipment returned to service after repair.

The procedures assume that the technical personnel are familiar with the test equipment used and can operate the equipment to produce the required inputs and obtain the required results (indications). Refer to the detailed operating procedures and descriptions of the SDU MPU included in this section.

**CAUTION:** ONLY AUTHORIZED TECHNICAL PERSONNEL WHO ARE TRAINED IN GENERAL AVIATION WORKMANSHIP AND HAVE A BASIC UNDERSTANDING OF SATCOM SYSTEMS SHOULD PERFORM THE OPERATIONAL AND DIAGNOSTIC TEST PROCEDURES IN THIS MANUAL.

**CAUTION:** CHANGES TO DEFAULT VALUES FOR SOME MENU FUNCTIONS MAY SERIOUSLY DEGRADE SYSTEM OPERATION.

**NOTE:** This manual describes the basic MPU functions, menus, and reports required for the testing and fault isolation procedures presented in this section. Please consult RCI Product Support before entering any unfamiliar menu selections not described in this manual.

**NOTE:** Using a terminal emulation program, open a log file and save all test results for future reference and test records.

**SYSTEM DESCRIPTION, INSTALLATION, AND MAINTENANCE MANUAL  
ARINC 781-200 SDU and SCM**

Refer to the Outline and Installation diagrams (Figure 3-1 to Figure 3-6) and the Interconnection and Contact Assignment drawings (Figure 3-7 to Figure 3-9) for additional information.

(1) Test Setup Procedure

The test setup procedure is presented in Table 4-6.

**Table 4-6 Test Setup Procedure**

Step	Action
1.0	Make sure that the SDU is powered down and disconnected from the power source.
2.0	Remove the maintenance-port connector cover.
3.0	Connect a maintenance cable to the SDU front-panel maintenance port connector.
4.0	Connect the other end of the cable to the serial port of the computer.
5.0	Open a log file to capture all test data. A log file is a text capture of the ASCII traffic between the computer attached to the maintenance port and the SDU.

(2) Post Test

When testing is completed, follow the steps in Table 4-7.

**Table 4-7 Post Test Procedure**

Step	Action
1.0	Save the log file of the test results (or data) for future reference.
2.0	Remove power from the SDU that was tested and from all other test equipment.
3.0	Disconnect test equipment from the SDU.
4.0	Replace the maintenance-port connector cover (if it was removed during the test setup).

If the Unit Under Test (UUT) **PASSED** the test, the unit is ready for service.

If the UUT **FAILED** the test, return the UUT along with a hardcopy printout of the recorded (captured) log file of the test results to the manufacturer for service and repair. Indicate the date of the test and the serial number of the UUT on the test documentation.

(3) Installation and Operational Verification Tests

To verify that the A781-200 system is ready for operation, use the following procedures:

- Power-On Test
- BITE

(a) Power-On Test

To complete the power-on test, follow the steps in Table 4-8.

Table 4-8 Power-On Test Procedure

Step	Action
1.0	Follow the test setup procedure in Table 4-6 on page 4-6.
2.0	Power-on the SDU.
3.0	Check the status of the front panel LEDs. Verify that the green LED flashes for 60 seconds and then turns off. Verify that the red LED is not illuminated. For more information about the LED signals, refer to "LEDs" on page 1-9.
4.0	Review the BITE status of all system components using the MCDU. Verify that all subsystems show OK status. For more information about using the MCDU and viewing BITE, refer to "Operating the MCDU" on page 2-2 and "BITE" on page 4-7.
5.0	Follow the post test procedure in Table 4-7 on page 4-6.

(b) BITE

If equipment connected to the A781-200 system provides wrong information or does not provide a signal to the A781-200 SDU, the SDU cannot function properly. You can check the status of connected equipment with the MCDU BITE screens. To check the status of connected equipment, follow the procedure described in "Viewing BITE Information" on page 2-15 and "Troubleshooting and Fault Isolation" on page 4-7.

The SATCOM BITE menu provides information about the results from BITE for various parts of the A781-200 system.

- If BITE fails the SDU or SCM, remove the component from service and return it to RCI—see "Maintenance and Repair" on page 5-1.
- If BITE fails a component other than the A781-200 SDU or SCM, verify the operation of that component and test the satellite communication system again.

## 2. Troubleshooting and Fault Isolation

This section provides troubleshooting procedures for A781-200 systems.

Troubleshooting procedures require data obtained using the MCDU. For specific instructions on how to access and use the MCDU, refer to "Operating the MCDU" on page 2-2.

**NOTE:** All of the MCDU menus discussed in this section are accessed from the SATCOM BITE menu.

### A. Subsystem Health

The SATCOM SUBSY HLTH menu provides the BITE status of subsystem components.

To check the subsystem health, on the SATCOM BITE menu, press the button next to **SUBSY HLTH**.

Figure 4-2 illustrates the SATCOM SUBSY HLTH menu.

**SYSTEM DESCRIPTION, INSTALLATION, AND MAINTENANCE MANUAL  
ARINC 781-200 SDU and SCM**



**Figure 4-2 SATCOM Subsystem Health Menu**

Table 4-9 describes the information available on the SATCOM SUBSY HLTH menu.

**Table 4-9 SATCOM Subsystem Health Menu**

<b>Label</b>	<b>Description</b>	<b>Action</b>
LNA	Reports the status of the LNA as OK, NO DATA (if golden label 350 from the antenna is missing or HGA is disconnected), TEST, or FAULT. The LNA status matches the HDA status.	If the status is NO DATA, check the bus connections from the Antenna and check the speed of bus.  If the status is FAULT, test or troubleshoot the LNA equipment.
ANT	Reports the status of the HGA as OK, FAULT, TEST, or NO DATA.	If the status is FAULT, test or troubleshoot the HGA equipment. If the status is NO DATA check the ARINC 429 bus from the Antenna.
CONFIG PARITY	Reports the status of the rear connector configuration parity as OK (parity is odd) or FAULT (parity is not odd). This status can be different from the setting of Bit 25 in Label 350 to the CMC, which is also set if the secure ORT is missing or invalid.	If the status is FAULT, check strapping—a non-supported configuration may be strapped.

**B. SATCOM System Bus**

The SATCOM SYSTEM BUS menu provides information about the bus status of equipment outside the A781-200 system. SATCOM services are not available if the equipment does not operate or communicate properly.



**SYSTEM DESCRIPTION, INSTALLATION, AND MAINTENANCE MANUAL  
ARINC 781-200 SDU and SCM**

To check the bus status, on the SATCOM BITE menu, press the button next to **SYS BUS**.

Figure illustrates the SATCOM System Bus menu.

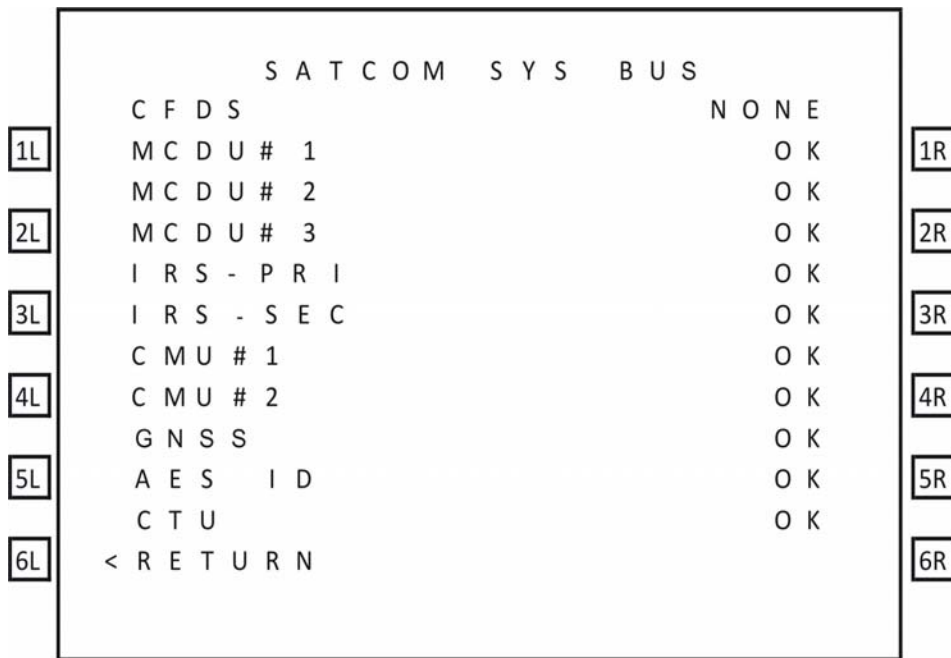

**Figure 4-3 SATCOM System Bus Menu**

Table 4-10 describes the information available on the SATCOM SYS BUS menu.

**Table 4-10 Bus Status Indicators**

Bus	Status			
	INACTIVE	NO DATA	NONE	OK
CFDS	The A781-200 does not support or receive input from the CFDS. Therefore the status will always be NONE.			
MCDU	No labels of correct speed on bus.	The expected Golden label (377) is not present.	The bus is not installed.	The expected Golden label is present and the bus is active at the correct speed.
IRS - PRI	No labels of correct speed on bus.	The expected Golden label (310) is not present.	N/A	The expected Golden label is present and the bus is active at the correct speed.

**Table 4-10 Bus Status Indicators**

Bus	Status			
	INACTIVE	NO DATA	NONE	OK
IRS - SEC	No labels of correct speed on bus.	The expected Golden label (310) is not present.	The IRS2Type secure ORT parameter specifies whether it is connected or not connected.	The expected Golden label is present and the bus is active at the correct speed.
GNSS	No labels of correct speed on bus.	The expected Golden label (110) is not present.	The bus is not installed.	The expected Golden label is present and the bus is active at the correct speed.
AES ID	No labels of correct speed on bus.	The expected Golden label (275) is not present.	The bus is not installed.	The expected Golden label is present and the bus is active at the correct speed.
CMU	No labels of correct speed on bus.	The expected Golden label (270) is not present.	The bus is not installed.	The expected Golden label is present and the bus is active at the correct speed.
CTU	Label 351 bit 27 is set to inactive.	N/A	The bus is not installed.	Label 351 bit 27 is set to OK.

**C. Thermal Status**

As shown in Figure 4-4, the SATCOM OVERTEMP menu reports the thermal status of system components.

To check the thermal status, on the SATCOM BITE menu, press the button next to **OVERTEMP**.



**Figure 4-4 SATCOM Overtemp Menu**

Table 4-11 describes the information available on the SATCOM OVERTEMP menu.

**Table 4-11 SATCOM OVERTEMP Menu**

Label	Description	Action
SDU	Reports the SDU thermal status as OK or FAIL.	If the status is FAIL, check the fan operation and temperature at the location of the equipment.
HGA	Reports the HGA thermal status as OK, NO DATA, or FAIL.	If the status is FAIL, check the fan operation and temperature at the location of the equipment.

**D. SCM Health**

As shown in Figure 4-5, the SATCOM SCM menu reports the status of the communication buses to the SCM and the status of the secure and user configuration tables.

**SYSTEM DESCRIPTION, INSTALLATION, AND MAINTENANCE MANUAL  
ARINC 781-200 SDU and SCM**

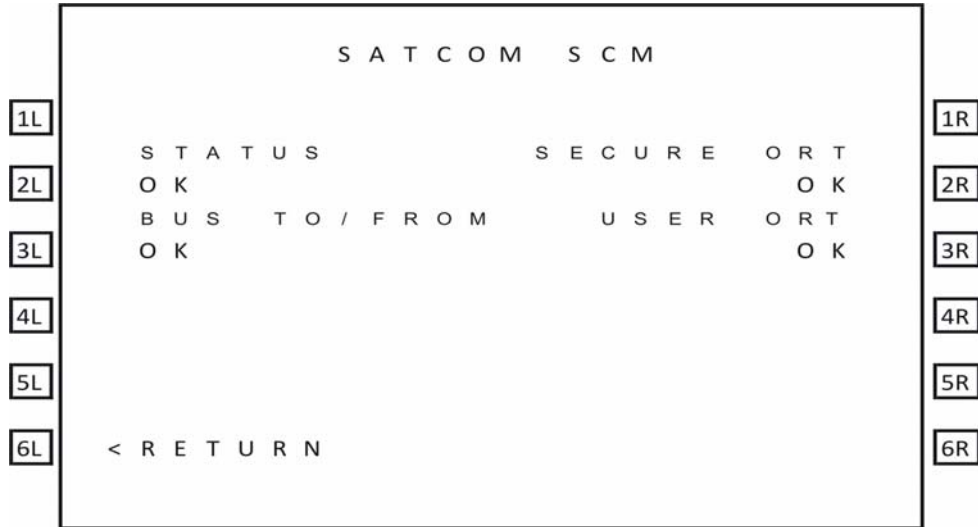

**Figure 4-5 SATCOM SCM Menu**

Table 4-12 describes the information available on the SATCOM SCM menu.

**Table 4-12 SATCOM SCM Menu**

<b>Label</b>	<b>Description</b>	<b>Action</b>
STATUS	Reports the SCM status as OK or FAIL.	If the status is FAIL, return the SCM to RCI the equipment supplier.
BUS TO/FROM	Reports the status of the bus to the SCM as OK or FAIL.	If the status is FAIL, check the connections to the SCM.
SECURE ORT	Reports the status of the Secure ORT as one of the following: NOT LOADED – No ORT in SCM memory. OK – Secure ORT is valid. INVALID – The Secure ORT is corrupted or otherwise invalid and must be reloaded.	If the status is INVALID or NOT LOADED, load a SECURE ORT file.
USER ORT	Reports the status of the User ORT as one of the following: NOT LOADED – No ORT in SCM memory. OK – User ORT is valid. INVALID – The User ORT is corrupted or otherwise invalid and must be reloaded.	If the status is INVALID or NOT LOADED, load a USER ORT file.

**E. Subsystem Bus Status**

As shown in Figure 4-6, the SATCOM SUBSY BUS menu reports the status of all subsystem buses that provide communication between the components of the system.

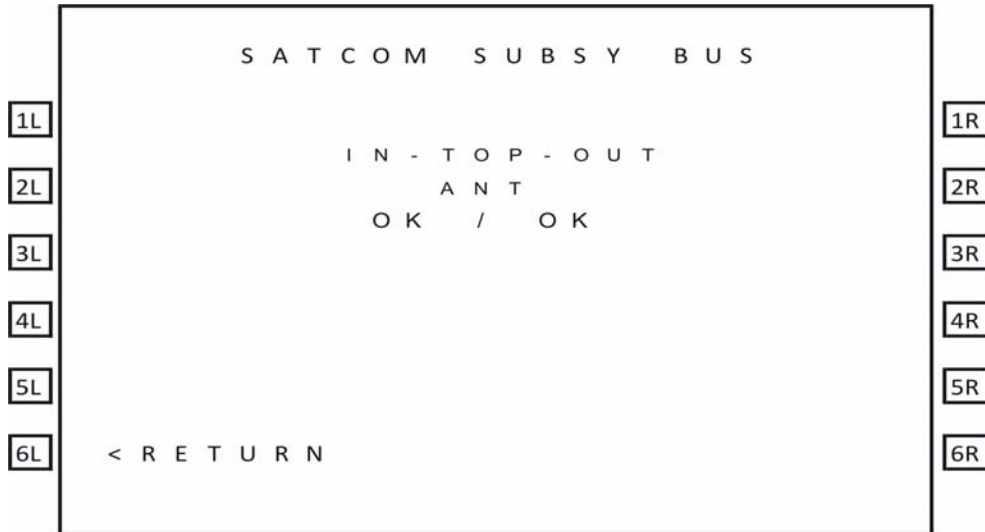

**Figure 4-6 SATCOM Subsystem Bus Menu**

Table 4-13 describes the information available on the SATCOM SUBSY BUS menu. Fields are left blank if the equipment is not included in the installation.

NOTE: Input and output are with respect to the SDU.

**Table 4-13 SATCOM SUBSY BUS Menu**

Label	Description	Action
ANT	Reports the status of the input and output buses for the antenna as OK, NO DATA, or FAIL.	If status is NO DATA, label 350 is missing—check the bus connections.

**F. RF Path Status**

As shown in Figure 4-7, the SATCOM RF PATH menu reports the status the RF paths.

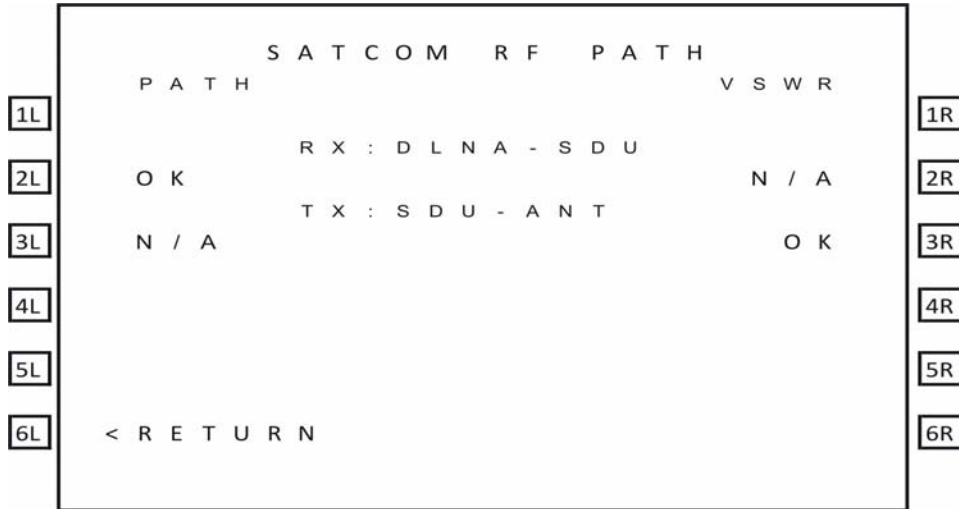

**Figure 4-7 SATCOM RF Path Menu**

Table 4-14 describes the information available on the SATCOM RF PATH menu.

**Table 4-14 SATCOM RF PATH Menu**

Label	Description
RX:DLNA-SDU	Reports the status of the RF path from the DLNA to the SDU as OK or FAULT.

**G. USIM and Data Bus Status**

As shown in Figure 4-8, the SATCOM USIM/DATA menu reports the status of the USIMs and data buses of the system.

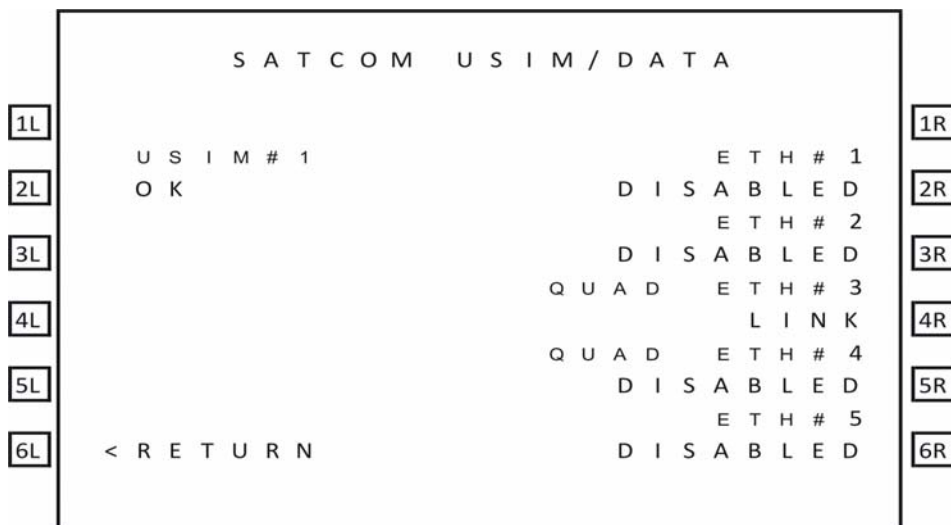

**Figure 4-8 SATCOM USIM/DATA Menu**

Table 4-15 describes the information available on the USIM/Data menu.

**Table 4-15 SATCOM USIM/DATA Menu**

Label	Description
USIM#1	Reports the status of USIM#1 bus as OK, WARMING, SBB LOG, FAULT, or N/A if channel card 1 is not in SBB mode.
ETH#1	Reports the status of ETH#1 bus as DISABLED, LINK, or NO LINK.
ETH#2	Reports the status of ETH#2 bus as DISABLED, LINK, or NO LINK.
QUAD ETH#3	Reports the status of QUAD ETH#3 bus as DISABLED, LINK, or NO LINK.
QUAD ETH#4	Reports the status of QUAD ETH#4 bus as DISABLED, LINK, or NO LINK.
ETH#5	Reports the status of ETH#5 bus as DISABLED, LINK, or NO LINK.
NOTE: Ethernet 1, 2, and 5 are not supported. Ethernet 4 is only used for application data loading.	

#### **H. ORT**

The A781-200 system may not function properly if the ORT parameters do not match the installed system.

##### **(1) Checking the ORT**

You can check the content of the ORT file through the maintenance port menus. "SDU Maintenance Port Utility (MPU)" on page 4-2 provides information about accessing the maintenance port menus.

**NOTE:** The ORT includes many parameters that affect internal operations. These parameters are not meaningful for technicians troubleshooting the satellite communication system.

To check the ORT:

1. In the maintenance port menus, navigate to menu 3.
2. To list the ORT, press **H**.  
The list of ORT parameters appears. The list is about eight pages long. Some ORT parameters displayed are system defaults that cannot be modified through the secure and user ORT files.
3. Compare the ORT parameters to the system installed in the aircraft.

#### **I. Contact Product Support**

When the troubleshooting procedures do not find a fault and the A781-200 system does not function properly, contact RCI Product Support.

RCI Product Support contact information:

**SYSTEM DESCRIPTION, INSTALLATION, AND MAINTENANCE MANUAL  
ARINC 781-200 SDU and SCM**

[RCI to complete]

RCI Product Support may ask you to capture and send them system specific logs and reports.

To access logs:

1. In the maintenance port menus, navigate to Menu 3.
2. Turn on the text capture feature of the terminal emulator on your computer. In HyperTerminal, click Transfer, and then click Capture Text.
3. To view the call log, in Menu 3, press **F**.
4. Turn off the text capture feature of the terminal emulator and send the captured file to RCI Product Support.

To access reports:

1. Turn on the text capture feature of the terminal emulator on your computer. In HyperTerminal, click Transfer, and then click Capture Text.
2. In the maintenance port menus, press EQUAL SIGN (=). A list of reports appears.
3. To activate a report, type the number next to the report description, and then press ENTER.

NOTE: RCI Product Support will specify the required reports, and may ask you to operate the A781-200 equipment while the reports gather information.

4. To stop a report, press EQUAL SIGN (=), then type the number of the report, and then press ENTER.

NOTE: To stop all reports, press X.

5. Turn off the text capture feature of the terminal emulator and send the captured file to RCI Product Support.

### **3. Adjustment/Alignment Procedures**

There are no adjustment/alignment procedures required for the A781-200 system.

### **4. Modification History**

The A781-200 system currently has no history of modifications.



## MAINTENANCE AND REPAIR

This section provides maintenance and repair information for the A781-200 system, including the following sections:

- Maintenance
- Repair
- Instructions for Continued Airworthiness
- Visual Inspection and Check

### 1. Maintenance

The A781-200 system does not require routine maintenance.

### 2. Repair

If functional problems occur, the SDU BITE identifies the faulty LRU.

As per continued airworthiness instructions, if an SDU or SCM is inoperative, use the Standard Practices Chapter of the Aircraft Maintenance Manual to:

- remove the unit
- secure cables and wiring
- collar applicable switches and circuit breakers, and placard them as “inoperative”

Before flight, revise the equipment list and weight and balance data as applicable, and record the removal of the unit in the log book [refer to section 91.213 of the FAR or the aircraft’s minimum equipment list (MEL)].

All repairs must be performed at the RCI equipment supplier factory.

### 3. Instructions for Continued Airworthiness

Periodic inspections of the mechanical and electrical interfaces of the A781-200 system components to the aircraft should be completed as defined by the governing airworthiness body’s Instructions for Continued Airworthiness (ICA) for the installation (for example, Transport Canada, the FAA, the EASA).

Installation of the ARINC 781 SATCOM Avionics System on an aircraft by Supplemental Type Certificate (STC) obligates the aircraft operator to include the maintenance information supplied by this manual in the operator’s Aircraft Maintenance manual and the operator’s Aircraft Scheduled Maintenance Program.

This section provides the special instructions and maintenance requirements for continued airworthiness of the A781-200 system.

**SYSTEM DESCRIPTION, INSTALLATION, AND MAINTENANCE MANUAL**  
**ARINC 781-200 SDU and SCM**

**A. Airworthiness Limitations**

When applicable, the Airworthiness Limitations section is FAA-approved, and specifies maintenance required under Title 14 Code of Federal Regulations (CFR) Part 43.16 and 14 CFR 91.403 of the Federal Aviation Regulations unless an alternative program has been FAA approved.

This section must be added to the Airplane Maintenance Manuals. The information contained herein supplements the Airplane Maintenance Manuals only in those areas covered by the A781-200 system installation. For limitations and procedures not contained in this supplement, consult the basic Airplane Maintenance Manuals.

The inspections and airworthiness limitations specified in this section are FAA approved. This section specifies the inspections and other maintenance required under sections 43.16 and 91.403 of the Federal Aviation Regulations unless an alternative program has been FAA approved.

**B. Electrical and Mechanical Inspection and Check**

Periodic inspections of the mechanical and electrical interfaces of the A781 system components to the aircraft should be completed as defined by the governing airworthiness body (for example, Transport Canada, the FAA, the EASA).

**C. Instructions for Continued Airworthiness**

The following paragraphs describe all maintenance requirements and instructions for continued airworthiness of the A781-200 system:

1. This manual contains maintenance information for the SDU and SCM, including system description, system operation, installation, test, and fault isolation.
2. Add the following information to the illustrated parts catalog for the aircraft:
  - all part numbers referred to in this manual
  - all LRUs referred to in this manual
3. Add all wiring diagram information contained in this manual to the aircraft operator's appropriate aircraft Wiring Diagram Manuals.
4. No additional or routine maintenance is required for the on-condition SDU or SCM.
5. If an SDU or SCM is inoperative, follow the instructions listed in "Repair" on page 5-1.
6. Return all units to the RCI equipment supplier factory for repair. See Appendix A: Return Material Authorization for detailed removal information and procedures.
7. Install repaired units on the aircraft in accordance with the installation instructions provided in this manual.
8. Make sure that all repaired units are operating before approving them for return to service, using the operational verification tests and procedures provided in this manual.
9. Enter the approval for return to service in the logbook, as required by section 43.9 of the FAR.

**SYSTEM DESCRIPTION, INSTALLATION, AND MAINTENANCE MANUAL  
ARINC 781-200 SDU and SCM**

10. Add the following scheduled maintenance tasks to the aircraft operator's appropriate aircraft maintenance program:
  1. Recommended periodic scheduled servicing tasks: None required.
  2. Recommended periodic inspections: as per the aircraft inspection and maintenance schedule.
  3. Recommended periodic scheduled preventative maintenance tests (tests to determine system condition and/or latent failures): None required.

#### **4. Visual Inspection and Check**

Perform the following procedures to inspect the SDU and SCM after installation of the units onto the aircraft.

Follow all approved safety standards and practices during the inspection.

1. Disconnect all circuit breakers to the SDU and SCM and associated systems.

**CAUTION: FAILURE TO DISCONNECT CIRCUIT BREAKERS CAN LEAD TO  
INJURY TO THE OPERATOR AND DAMAGE TO THE EQUIPMENT.**

2. Examine the connection for loose, damaged, or missing hardware.
3. Examine cables and connections. Contact RCI Product Support to gauge the severity of the damage if you find:
  - corrosion
  - chafing
  - wear
  - damage
4. Tighten any loose connectors to the manufacturer's recommended value.

Blank Page

# APPENDIX A: RETURN MATERIAL AUTHORIZATION

To return equipment to RCI for repair, this RMA procedure must be followed. Failure to comply with this procedure may result in shipping delays and additional charges.

## 1. Warranty Returns

Equipment that qualifies for warranty repair can be returned to RCI for repair or replacement at their discretion. The customer shall pay the shipping costs to RCI and RCI will pay the shipping costs to return the repaired/replaced unit to the customer.

## 2. Non-Warranty Returns

Equipment that fails to work properly because of improper or negligent use, abuse, shipping damage, or any other condition can still be returned to RCI for repair or replacement at their discretion. The customer will be notified of the cost to repair or replace the unit before invoicing for the repair or replacement. The customer shall pay for the shipping costs to and from RCI.

## 3. Repackaging Requirements

ARINC 781 SDU or SCM components must be returned to RCI in approved shipping containers. Failure to do so may invalidate the warranty.

If SDU or SCM shipping containers are unavailable, they can be ordered from RCI when requesting the RMA number.

## 4. RMA Procedure

If it is determined that equipment must be returned to RCI for repair or overhaul, follow the RMA procedure below.

1. Have the following information ready before calling RCI Product Support:
  - Model (e.g., A781-200 SDU)
  - Unit part number (e.g., 1530-A-1100, 1530-A-1300-01 or 1530-A-1300-02)
  - Serial number
  - Description of failure
  - Aircraft tail number, serial number, and aircraft model number
2. Call RCI Product Support at [RCI to complete].
3. An RCI Product Support specialist will attempt to resolve the problem by telephone. If equipment must be returned to RCI, the Product Support Specialist will authorize the R&O Coordinator to issue an RMA number.
4. Pack the equipment in the original shipping container or a container approved by RCI.

**SYSTEM DESCRIPTION, INSTALLATION, AND MAINTENANCE MANUAL  
ARINC 781-200 SDU and SCM**

5. Write the RMA number on the outside of the shipping container and on all shipping documents, enclose a copy in the box, and send your prepaid shipment to RCI.  
[RCI to complete]
6. Fax or email the details of the shipment to the R&O Coordinator, including the following information: Shipment date, carrier name, and the waybill number.
7. The processing of LRU returns is limited to standard business hours from 8:30 am to 5:00 pm EST. For general inquires and status requests, contact the R&O department directly:  
Phone: [RCI to complete]  
Email: [RCI to complete]  
Fax: [RCI to complete]