



FCC Part 24E Transmitter Certification

Test Report

FCC ID: DNY0A5EPPCS8REM

FCC Rule Part: CFR 47 Part 24 Subpart E

ACS Report Number: 06-0474-24E

Manufacturer: EMS Wireless
Equipment Type: PCS Fiber Optic DAS
Tradename: EkoLink Plus[®] II
Model: EPPCS8REM

Manual

Operator's Manual

EkoLink Plus[®] Fiber Optic Distributed Antenna System



EMS[™]
Wireless
A Division of EMS Technologies, Inc.

900-5000-017 REV. B

2850 Colonnades Court
Norcross, GA 30071
770.582.0555
Fax 770.729.0075

Disclaimer

Every attempt has been made to make this material complete, accurate, and up-to-date. Users are cautioned, however, that EMS *Wireless* reserves the right to make changes without notice and shall not be responsible for any damages, including consequential, caused by reliance on the material presented, including, but not limited to, typographical, arithmetical, or listing errors.

Copyright Information

© 2001 by EMS *Wireless*

**EMS Wireless
Norcross, GA**



WARNINGS, CAUTIONS, AND GENERAL NOTES

This product conforms to FCC Part 15, Section 21. Changes or modifications not expressly approved by the party responsible for compliance could void the user's authority to operate the equipment. .

NOTE: This equipment has been tested and found to comply with the limits for a Class B digital device, pursuant to Part 15 of the FCC Rules. These limits are designed to provide reasonable protection against harmful interference in a residential installation. This equipment generates, uses, and can radiate radio frequency energy and, if not installed and used in accordance with the instructions, may cause harmful interference to radio communications. However, there is no guarantee that interference will not occur in a particular installation. If this equipment does cause harmful interference to radio or television reception, which can be determined by turning the equipment off and on, the user is encouraged to try to correct the interference by one or more of the following measures:

- Reorient or relocate the receiving antenna.
- Increase the separation between the equipment and receiver.
- Connect the equipment into an outlet on a circuit different from that to which the receiver is connected.
- Consult the dealer or an experienced radio/TV technician for help.

This Class B digital apparatus meets all requirements of the Canadian Interference Causing Equipment Regulations. Operation is subject to the following two conditions: (1) this device may not cause harmful interference, and (2) this device must accept any interference received, including interference that may cause undesired operation.

Cet appareillage numérique de la classe B répond à toutes les exigences de l'interférence canadienne causant des règlements d'équipement. L'opération est sujette aux deux conditions suivantes: (1) ce dispositif peut ne pas causer l'interférence nocive, et (2) ce dispositif doit accepter n'importe quelle interférence reçue, y compris l'interférence qui peut causer l'opération peu désirée.

Installation should be made per ANSI/NFPA 70, the National Electrical Code(NEC), Article 810 specifically for clearances from power and lighting conductors, mounting and grounding.

The screen of the coax cable must be connected to earth(grounded) at the entrance to the building. This should be done in accordance with applicable National Electrical Code(NEC) installation codes. In the U.S., this is required by Section 820.93 of the National Electrical Code, ANSI/NFPA 70.

IC Requirements

The Manufacturer's rated output power of this equipment is for single carrier operation. For situations when multiple carrier signals are present, the rating would have to be reduced by 3.5 dB, especially where the output signal is re-radiated and can cause interference to adjacent band users. This power reduction is to be by means of input power or gain reduction and not by an attenuator at the output of the device.

Safety Considerations

When installing or using this product, observe all safety precautions during handling and operation. Failure to comply with the following general safety precautions and with specific precautions described elsewhere in this manual violates the safety standards of the design, manufacture, and intended use of this product. EMS Wireless assumes no liability for the customer's failure to comply with these precautions.

WARNING

WARNING Calls attention to a procedure or practice, which, if ignored, may result in damage to the system or system component. Do not perform any procedure preceded by a WARNING until described conditions are fully understood and met.

If You Need Help

If you need additional copies of this manual, or have questions about system options, or need help with installation and using of the system, please contact EMS Wireless' Customer Support Department.



Service

Do not attempt to modify or service any part of this product other than in accordance with procedures outlined in this Operator's Manual. If the product does not meet its warranted specifications, or if a problem is encountered that requires service, notify EMS *Wireless*' Customer Support department. Service will be rendered according the EMS *Wireless*' warranty and repair policy. The product shall not be returned without contacting EMS *Wireless* and obtaining a return authorization number from the Customer Service department

When returning a product for service, include the following information: Owner, Model Number, Serial Number, Return Authorization Number (obtained in advance from EMS *Wireless* Customer Service Department), service required and/or a description of the problem encountered.

Warranty and Repair Policy

The EMS *Wireless* Quality Plan includes product test and inspection operations to verify the quality and reliability of our products.

EMS *Wireless* uses every reasonable precaution to ensure that every device meets published electrical, optical, and mechanical specifications prior to shipment. Customers are asked to advise their incoming inspection, assembly, and test personnel as to the precautions required in handling and testing ESD sensitive opto-electronic components. Physical damage to the external surfaces voids warranty.

These products are covered by the following warranties:

1. General Warranty

EMS *Wireless* warrants to the original purchaser all standard products sold by EMS *Wireless* to be free of defects in material and workmanship for the duration of the warranty period of two (2) years from date of shipment from EMS *Wireless*. During the warranty period, EMS *Wireless*' obligation is limited to repair or replacement of any product that EMS *Wireless* proves to be defective. This warranty does not apply to any product, which has been subject to alteration, abuse, improper installation or application, accident, electrical or environmental over-stress, negligence in use, storage, transportation or handling.

2. Specific Product Warranty Instructions

All EMS *Wireless* products are manufactured to high quality standards and are warranted against defects in workmanship, materials and construction, and to no further extent. Any claim for repair or replacement of a device found to be defective on incoming inspection by a customer must be made within 30 days of receipt of the shipment, or within 30 days of discovery of a defect within the warranty period.

This warranty is the only warranty made by EMS *Wireless* and is in lieu of all other warranties, expressed or implied, except as to title, and can be amended only by a written instrument signed by an officer of EMS *Wireless*. EMS *Wireless* Customer Support agents or representatives are not authorized to make commitments on warranty returns.

In the event that it is necessary to return any product against the above warranty, the following procedure shall be followed:

- a. Return authorization shall be received from EMS *Wireless* Customer Support prior to returning any device. Advise EMS *Wireless* Customer Support of the model, serial number, and the discrepancy. The device shall then be forwarded to EMS *Wireless*, transportation prepaid. Devices returned freight collect or without authorization may not be accepted.
- b. Prior to repair, EMS *Wireless* Customer Support will advise the customer of EMS *Wireless* test results and will advise the customer of any charges for repair (usually for customer caused problems or out-of-warranty conditions).

If returned devices meet full specifications and do not require repair, or if the customer does not authorize non-warranty repairs, the device may be subject to a standard evaluation charge. Customer approval for the repair and any associated costs will be the authority to begin the repair at EMS *Wireless*. Customer approval is also necessary for any removal of certain parts, such as connectors, which may be necessary for EMS *Wireless* testing or repair.

- c. Repaired products are warranted for the balance of the original warranty period, or at least 90 days from date of shipment.

3. Limitations of Liabilities

EMS Wireless' liability on any claim of any kind, including negligence, for any loss or damage arising from, connected with, or resulting from the purchase order, contract, or quotation, or from the performance or breach thereof, or from the design, manufacture, sale, delivery, installation, inspection, operation or use of any equipment covered by or furnished under this contract, shall in no case exceed the purchase price of the device which gives rise to the claim.

EXCEPT AS EXPRESSLY PROVIDED HEREIN, EMS WIRELESS MAKES NO WARRANTY OF ANY KIND, EXPRESSED OR IMPLIED, WITH RESPECT TO ANY GOODS, PARTS AND SERVICES PROVIDED IN CONNECTION WITH THIS AGREEMENT INCLUDING, BUT NOT LIMITED TO, THE IMPLIED WARRANTIES OF MERCHANTABILITY AND FITNESS FOR A PARTICULAR PURPOSE. EMS WIRELESS SHALL NOT BE LIABLE FOR ANY OTHER DAMAGE INCLUDING, BUT NOT LIMITED TO, INDIRECT, SPECIAL OR CONSEQUENTIAL DAMAGES ARISING OUT OF OR IN CONNECTION WITH FURNISHING OF GOODS, PARTS AND SERVICE HEREUNDER, OR THE PERFORMANCE, USE OF, OR INABILITY TO USE THE GOODS, PARTS AND SERVICE.

EMS Wireless test reports or data indicating mean-time-to-failure, mean-time-between-failure, or other reliability data are design guides and are not intended to imply that individual products or samples of products will achieve the same results. These numbers are to be used as management and engineering tools, and are not necessarily indicative of expected field operation. These numbers assume a mature design, good parts, and no degradation of reliability due to manufacturing procedures and processes.

This fiber optic laser transmitter contains a class IIIb laser product as defined by the US Department of Health and Human Services, Public Health Service, Food and Drug Administration. This laser product complies with 21 CFR, Chapter I, Subchapter J of the DHEW standards under the Radiation Control for Health and Safety Act of 1968. The laser module certification label is located on the equipment enclosure and it also shows the required **DANGER** warning logotype (as shown below).

The EMS *Wireless* laser products are used in optical fiber communications systems for radio frequency and microwave frequency analog fiber optic links. In normal operation, these systems are fully enclosed and fully shielded by the hermetically sealed laser metal package. Laser bias current is limited by the internal control circuitry. The transmitters are coupled to glass fiber and have 1310/1550 nm optical output wavelength with typically 0.5 to 20 mW output depending on the model. The optical radiation is confined to the fiber core. Under these conditions, there is no accessible laser emission and hence no hazard to safety or health.

Since there is no human access to the laser output during system operation, no special operator precautions are necessary when fiber is connected to the transmitter and receiver. **During installation, service, or maintenance, the service technician is warned, however, to take precautions, which include not looking directly into the fiber connector or the fiber that is connected to the fiber connector before it is connected to the fiber optic receiver. The light emitted from the fiber optic connector or any fiber connected to the connector is invisible and may be harmful to the human eye. Use either an optical power meter or an infrared viewer or fluorescent screen for optical output verification. All handling precautions as outlined by the FDA and ANSI Z136.2 and other authorities of class IIIb lasers must be observed.**

Do not attempt to modify or to service this Product. Contact the EMS *Wireless* Customer Support Department for a return authorization if service or repair is necessary.



Handling the EkoLink Plus

1. Use ESD (electrostatic discharge) precautions when dealing with the modules within the EkoLink Plus so that units are not damaged.
2. Opening any module voids the warranty.
3. Modules cannot be "hot-swapped" (removed while unit is in operation). Disconnecting any component within the EkoLink Plus when powered can damage or destroy the equipment and will void the warranty. Unit must not be operating when modules are removed for replacement.

TABLE OF CONTENTS

- 1.0 General Information**
- 2.0 Equipment Mounting and Installation**
 - 2.1 Hub Mounting**
 - 2.2 Remote Mounting**
 - 2.3 Cabling**
- 3.0 System Set-up and Turn-on**
 - 3.1 Automatic Set-up**
 - 3.1.1 Hub Set-up**
 - 3.1.2 Remote Set-up**
 - 3.2 Manual System Set-up**
- 4.0 System Optimization**
- 5.0 Major Modular Components – Technical Description**
 - 5.1 Remote Unit**
 - 5.1.1 Channelizer Modules**
 - 5.1.2 Power Amplifier**
 - 5.1.3 Power Supply Module**
 - 5.1.4 Duplex Filter**
 - 5.1.5 Status and Control Module**
 - 5.1.6 Interconnect Module**
 - 5.1.7 Fiber Optic Transceiver**
 - 5.2 Hub Unit**
 - 5.2.1 Hub Interface Module**
 - 5.2.2 Fiber Optic Transceiver**
 - 5.2.3 Hub Control Module**
 - 5.2.4 Hub Power Supply Module (Optional)**
- 6.0 EkoLink Plus Specifications**
 - 6.1 EkoLink Plus RF Specifications**
 - 6.2 EkoLink Plus Mechanical Specifications – Remote**
 - 6.3 EkoLink Plus Mechanical Specifications – Hub**
 - 6.4 EkoLink Plus Environmental Specifications**
- 7.0 Detailed Software Commands**
 - 7.1 General**
 - 7.2 Software Command Set**
 - 7.3 Communication via the MirrorCell Unit Manager**

Appendix A: Installing the Wireless Modem into an EkoLink Plus

Appendix B: HyperTerminal Configuration

TABLE OF FIGURES

Figure 1: Mechanical Diagram of the EkoLink Plus Hub, Rack Mount Configuration

Figure 2: Mechanical Diagram of the EkoLink Plus Hub, Waterproof Housing Configuration

Figure 3: Mechanical Diagram of EkoLink Plus Remote Unit

Figure 4: Rack Mounted EkoLink Plus Hub

Figure 5: Wall Mounted EkoLink Plus Hub

Figure 6: Wall Mounted Remote Unit

Figure 7: Remote Unit with Optional Battery Back-up Unit

Figure 8: EkoLink Plus Cabling Connections

Figure 9: Remote Unit Connections

Figure 10: Neighbor List Changes

Figure 11: General Block Diagram of EkoLink Plus System

Figure 12: Block Diagram of EkoLink Plus Hub

Figure 13: EkoLink Plus Remote Unit Block Diagram

Figure B-1: Connection Description in HyperTerminal

Figure B-2: HyperTerminal Screen for Direct Connection

Figure B-3: HyperTerminal Screen for Modem Connection

Figure B-4: Port Settings for Direct Connection and Remote Connection

LIST OF TABLES

Table 1: Default User Names and Passwords

Table 2: EkoLink Plus RF Specifications

Table 3: EkoLink Plus Remote Mechanical Specifications

Table 4: EkoLink Plus Hub Mechanical Specifications

Table 5: EkoLink Plus Environmental Specifications

Table 6: Manual Software Command List

1.0 GENERAL INFORMATION

The EkoLink Plus Fiber Optic Distributed Antenna System (DAS), provides excellent signal coverage of most all large buildings, multiple buildings, airports, convention centers as well as large outdoor environments such as university campuses, rural stretches of highway, etc. With the correct selection of equipment, this can include a combination of outdoor and in-building coverage for multi-building office parks, etc.

The EkoLink Plus System offers these general features:

- Remote alarming through the hub unit. This allows technicians to monitor system performance remotely via telephone line and computer with modem and terminal software.
- Truly “plug and play” operation, with a totally automatic software set-up sequence, in the hub and all remote units, or manual control capability for specific setups.
- Remote units have true automatic gain control to allow compensation for RF source variations, optical loss, or other variations in power level.
- The monitoring and control of the system occurs with a direct connection to a laptop computer, wireless modem, or via a wireline option for remote access.
- The system uses single mode fiber optic cable to connect the hub to the remote(s). This eliminates the large signal losses inherent in long runs of coax or CAT 5 (twisted pair) cables used in other systems. For this reason, very long (up to five kilometers) fiber optic cables can be used to provide coverage very far away from the hub unit in large complexes of buildings or large outdoor areas.
- The unit operates with +20 dBm RF donor signal level, which is conveniently obtained via direct coaxial cable launch from a BTS with appropriate attenuators. The advantage of using a dedicated micro BTS for the DAS is dramatically increased system capacity within the covered building. The BTS interface is a pair of coaxial connections to independent receive and transmit ports. Optionally an interface is available to connect to a duplexed BTS output.
- The Eko Link Plus is a band selective Fiber Optic Distributed Antenna System (DAS), designed to be fully compliant with GSM-AMPS-TDMA-CDMA standards.
- Standard downlink path output power is 2 watts (+33 dBm), 4 watts (+36 dBm), 8 watt (+39 dBm) or 20 watt (+43 dBm) composite. The uplink path provides an approximate 3 dB system overall gain.
- The EkoLink Plus can be optionally configured with two independent passbands for each radio frequency path. This means that two PCS bands can be covered

with one system. At Cellular 800 MHz, A + A' + A" or B + B' extended band segments can be covered with one unit.

- The EkoLink Plus system will support up to four remotes per hub or two remotes with the diversity receive option. Diversity receive is accomplished by processing an additional receive signal (using a second receive antenna) at a particular remote unit. This signal is sent via fiber optic cable back to the hub unit. This allows for spatial or polarization diversity to be supported, similar to a BTS.
- Optionally, Wave Division Multiplexing (WDM) can be added to the system, allowing for a single fiber optic cable from the hub to each remote, which handles both uplink and downlink signals.
- An optional wireless or wireline modem can be equipped at the remotes and or at the hub location. The modem allows for remote alarm and control of the units via MUM software or a laptop computer.

More specific technical features can be found in the Technical Specifications and the Technical Description sections of this Operator's Manual.

Figure 1 shows a mechanical diagram of the Hub in the rack mount configuration. Figure 2 shows the hub in the optional waterproof housing, and Figure 3 shows the remote unit.

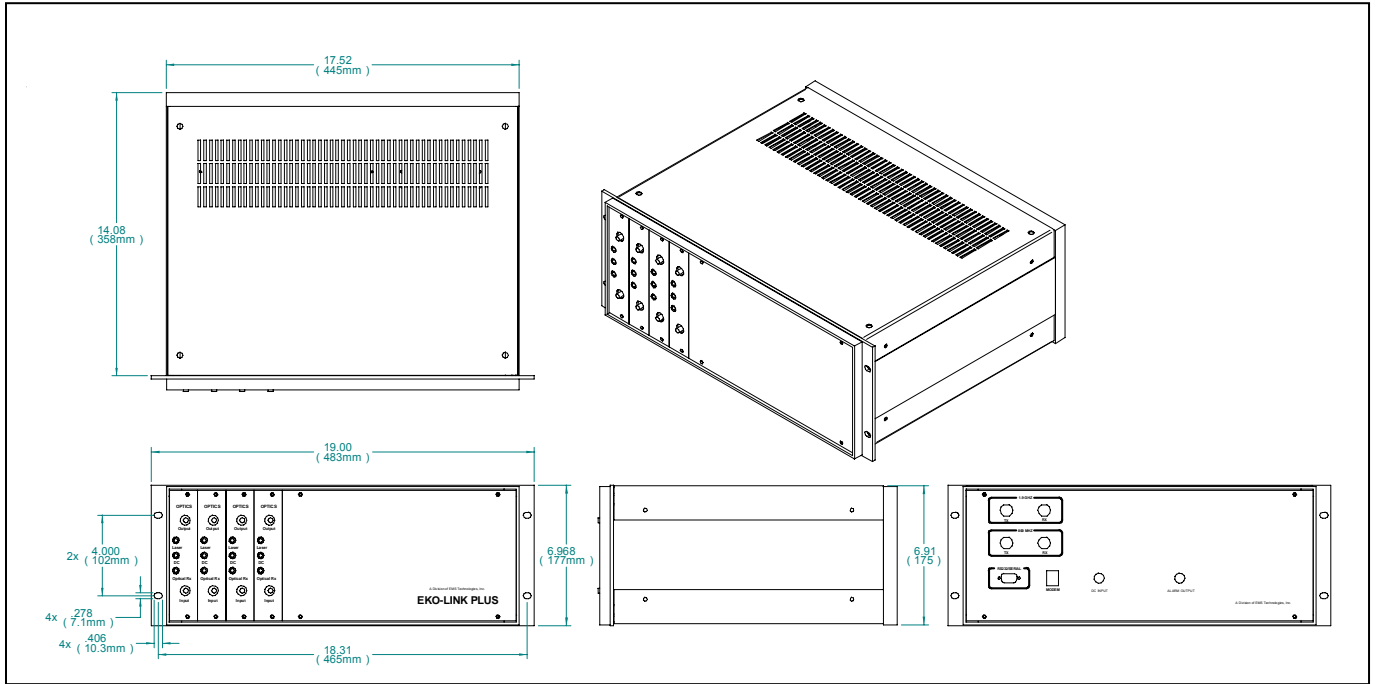

Figure 1: Mechanical Diagram of the EkoLink Plus Hub, Rack Mount Configuration

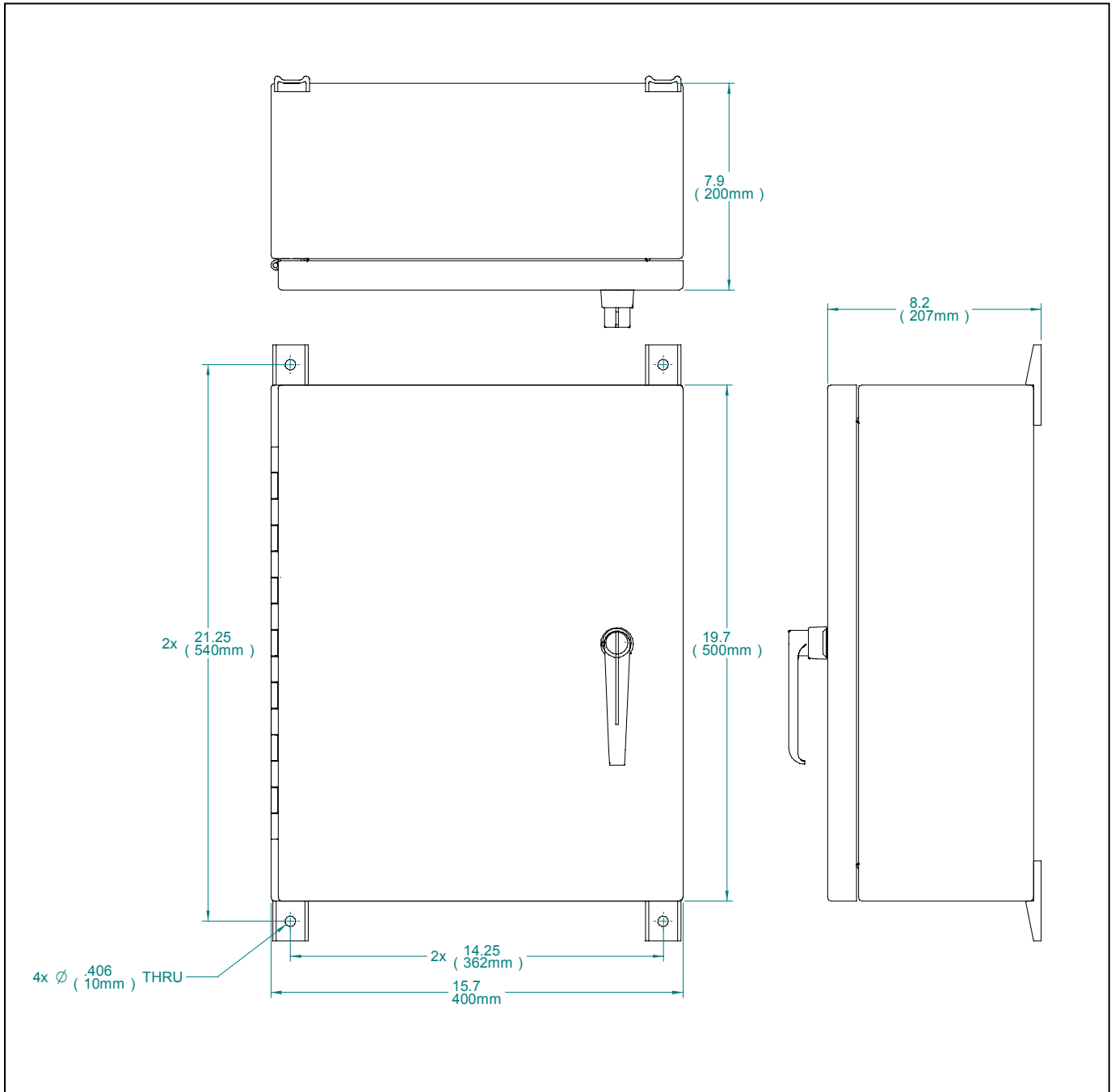

Figure 2: Mechanical Diagram of the EkoLink Plus Hub, Waterproof Housing Configuration

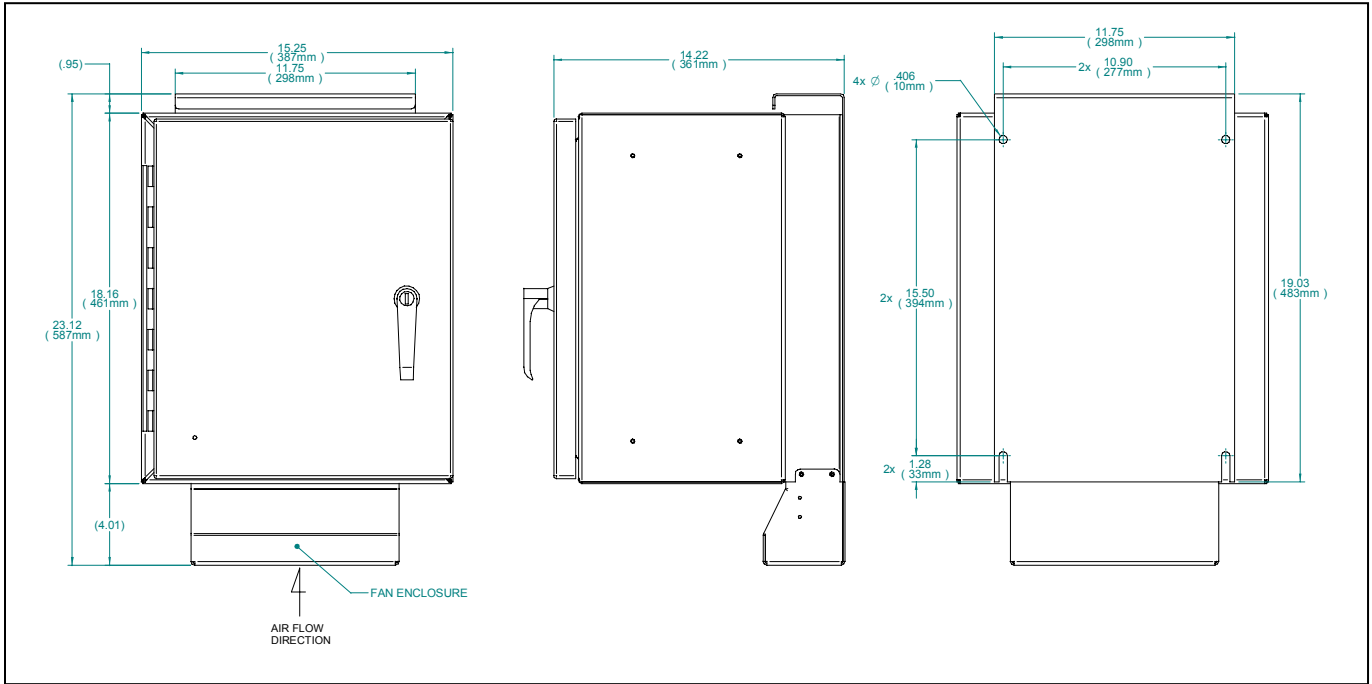

Figure 3: Mechanical Diagram of EkoLink Plus Remote Unit

2.0 Equipment Mounting and Installation

The following general recommendations should be adhered to for optimal performance.

1. The remote units should be mounted so the heatsink avoids direct sunlight. This will extend the life of these units.
2. The remote units must be mounted upright so that the connectors are on the underside. This will help prevent a buildup of moisture inside the cabinet.
3. The hub and remotes are equipped with N-type antenna connectors. Connectors are located on the bottom of the remote cabinet.
4. Ensure that adequate room has been allocated for the bending radius of the cables. Refer to the cable manufacturer's specifications for the allowable cable-bend radius.
5. Ensure that adequate room is allowed for the opening and closing of the remote unit door. See the specification table for dimensions of the cabinet.

2.1 Hub Mounting

The hub should be mounted as close as possible to the donor BTS. The 19" (48.3 cm) rack mount version is shown in Figure 4. The alternate NEMA 4 weatherproof wall mounted enclosure is shown in Figure 5. Observe all environmental specifications for the hub to avoid damage from moisture, heat, cold, etc.



Figure 4: Rack Mounted EkoLink Plus Hub

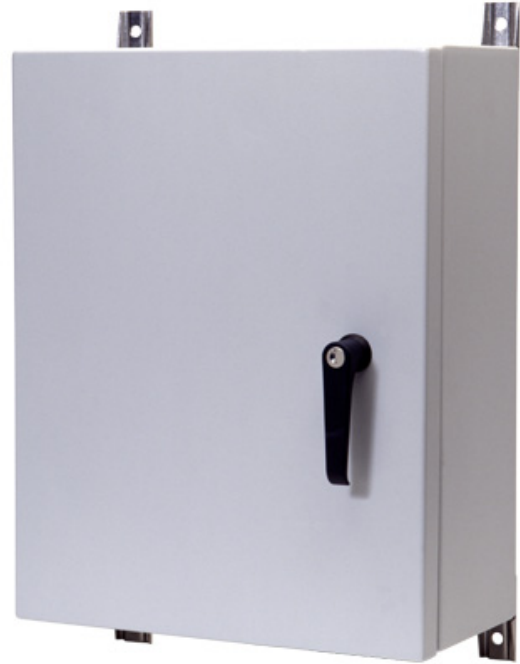

Figure 5: Wall mounted EkoLink Plus Hub

2.2 Remote Mounting

Ensure that each remote location is as close as possible to the antenna(s) it serves. Observe all environmental specifications for the remote to avoid damage from moisture, heat, cold, etc.

An example of the wall mounted remote is shown in Figure 6. A battery back-up unit may be included as part of the system. This unit should be mounted close to the EkoLink Plus remote, as shown in Figure 7.

Pole mounting is another popular method of mounting the remote. U-bolts and “unistrut” stock may be used to easily mount the remote.



Figure 6: Wall mounted remote unit

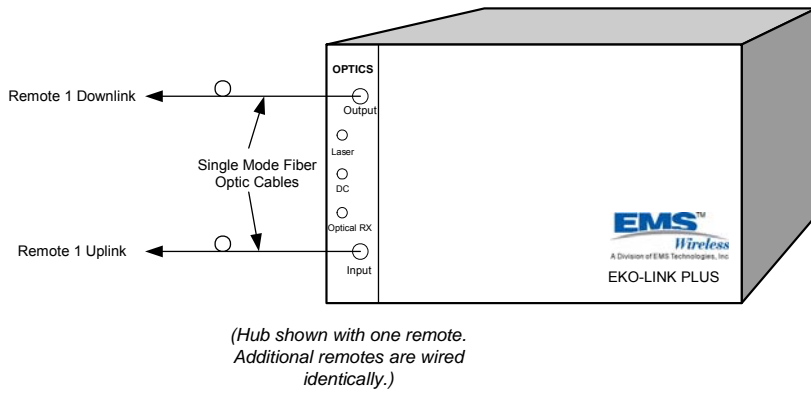

Figure 7: Remote Unit with optional Battery Back-up Unit

2.3 Cabling

A cabling schematic showing the hub connections is shown in Figure 8. The remote connections are shown in Figure 9.

EkoLink Plus Hub Connections (Configured without WDM, and without Receive Diversity)



Typical EkoLink Plus Hub front panel shown with two RF/Optical Transceivers Installed

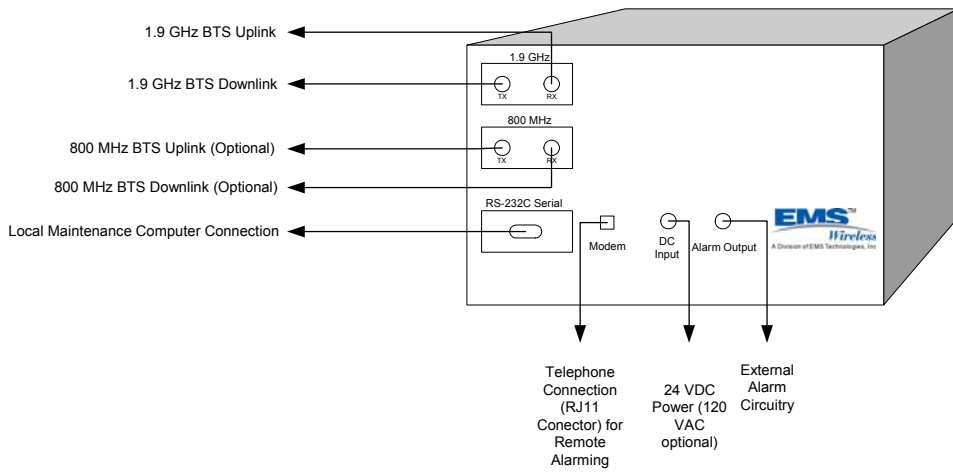

Typical EkoLink Plus Hub Rear Panel with 1900 MHz only

Figure 8: EkoLink Plus Hub Cabling Connections

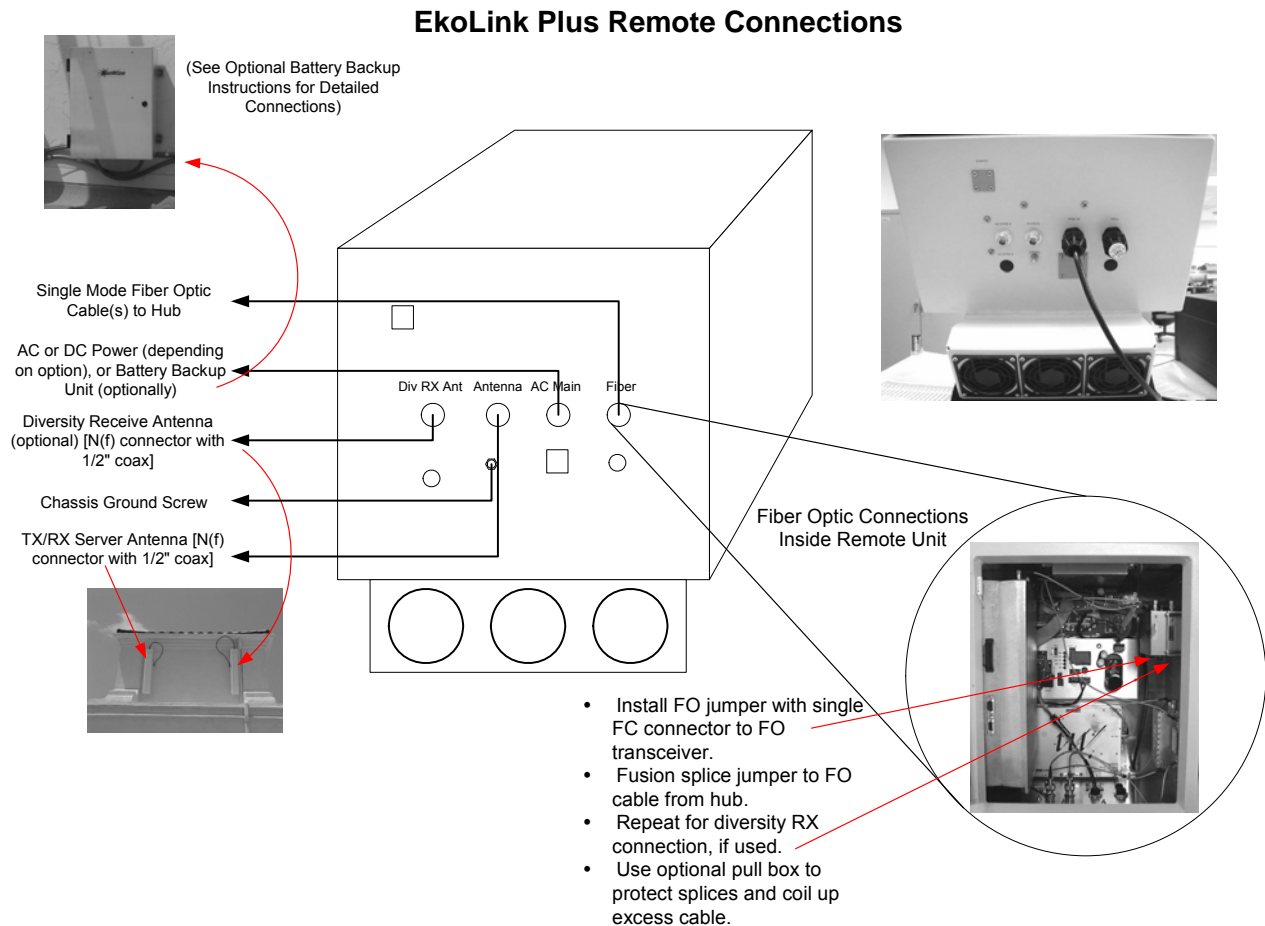

Figure 9: Remote Unit Connections

3.0 System Set-up and Turn-on

The EkoLink Plus hub and remotes can be configured locally through a laptop computer and its RS-232 serial communications port. Once the system is configured, it can be controlled using an optional telephone line interface.

The following is a summary procedure for configuring the EkoLink Plus using its built-in automatic software. More detailed software commands for specific configurations can be found later in this manual.

WARNING!
**DO NOT TURN ON THE POWER UNLESS THE REMOTE UNIT(S)
ARE CONNECTED TO ANTENNAS OR ATTENUATORS ON THE
SERVER ANTENNA PORT!**

3.1 Automatic Set-up:

3.1.1 Hub Set-up:

Connect the computer using an RS232 serial port with a DB9 male connector (on cable end for the repeater) to the hub status and control module in the repeater.

Use a terminal emulation program, such as ProComm or HyperTerminal, set to:

- VT-100 series terminal emulation
- 9600 baud
- 8 bit
- 1 stop bit
- no parity
- no flow control (flow control = none)

Turn the hub on, followed by each remote unit. Press the 'Enter' key on the computer to initialize the login screen.

Note: Login may take several seconds if the repeater is in active communications mode. To bypass sending all of the alarms, press 'ENTER' as soon as the date and time appear on the screen.

Note: For assistance, type 'HELP' for a list of available commands.

Login to the system using one of the default Usernames and Passwords shown in Table 1 below. Both the Username and Password are CASE SENSITIVE. Do not use the number pad on the keyboard to input numbers.

Table 1: Default User Names and Passwords

User Name	Password	Authority
USERNAM1	PASSWRD1	Read/write
USERNAM2	PASSWRD2	Read/write
USERNAM3	PASSWRD3	Read only
USERNAM4	PASSWRD4	Read only

Change the default Username and Password. Each Username and Password can have a maximum of eight characters. For example, to change the second Username and Password, enter the following two commands:

```
SET PWD#[password]<enter>
```

```
SET UID#[password]<enter>
```

Type 'RESTART' followed by the "enter" key. This command will re-set all the software settings and allow the set-up routine to measure the RF signal levels and set the attenuators appropriately.

Type 'EXIT' to log off the EkoLink Plus hub. Disconnect the RS-232 cable from the hub.

3.1.2 Remote Set-up:

Move the computer and serial cable to each of the remote units. Log on to each remote unit using the same procedure as above for the hub unit.

At each remote, look at the status screen. If necessary, adjust the peak RF output level by using the SET PEAK command. For example,

```
SET PEAK 24
```

This command will set the RF output power to 1 dB less than the command value. In this example, the RF output from the remote unit will be +23 dBm.

Type the RESTART command. This command should initialize the software sequence, and set up the remote so it will transmit at the power level set in the previous step.

Note: To transmit the minimum necessary power, the repeater automatic setup will set the attenuation for maximum. Then, attenuation levels are reduced until the desired output power is achieved. The uplink (reverse) attenuation is automatically set equal to the downlink (forward) attenuation to maintain path balance.

The repeater should now be properly configured for operation.

3.2 Manual System Set-up:

There is an extensive list of software commands that may be used with the EkoLink Plus. These commands will override the automatic system set up feature and will require the user to manually adjust both the down link and up link attenuation. The complete list of commands may be found in Section 8.

4.0 System Optimization

Now that the EkoLink Plus is providing the desired output power, the local repeater system needs to be optimized. The neighbor lists of the donor base station should be reviewed. The repeater uses highly selective Surface Acoustic Wave (SAW) filters, which have a group delay of approximately 3 microseconds. Since the propagation delay of free space is 5.4 microseconds per mile, the delay is “equivalent” to approximately 1/2 of a mile of free space propagation.

The neighbor lists of the donor base station and the base stations surrounding the area served by the repeater need to be adjusted. For example, in Figure 10, a repeater or DAS extends the coverage of BTS1 to a new area. BTS1 is now neighbors with BTS4 and BTS5, whereas without the repeater, BTS1 is neighbors with just BTS2 and BTS3. Thus BTS4 and BTS5 must be added to BTS1's neighbor list, and BTS1 must be added to BTS4's and BTS5's neighbor lists. A drive test of the coverage area should be performed to verify the final setup.

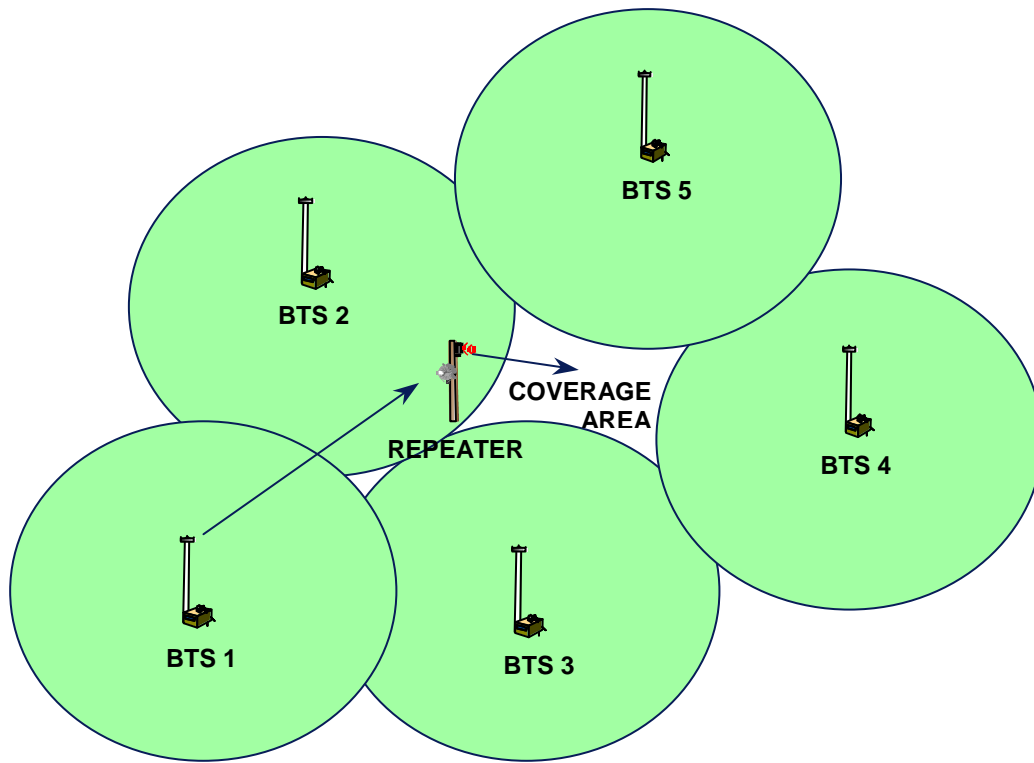

Figure 10. Neighbor List Changes

5.0 Major Modular Components – Technical Description

Figure 11 below shows a general block diagram of the EkoLink Plus System.

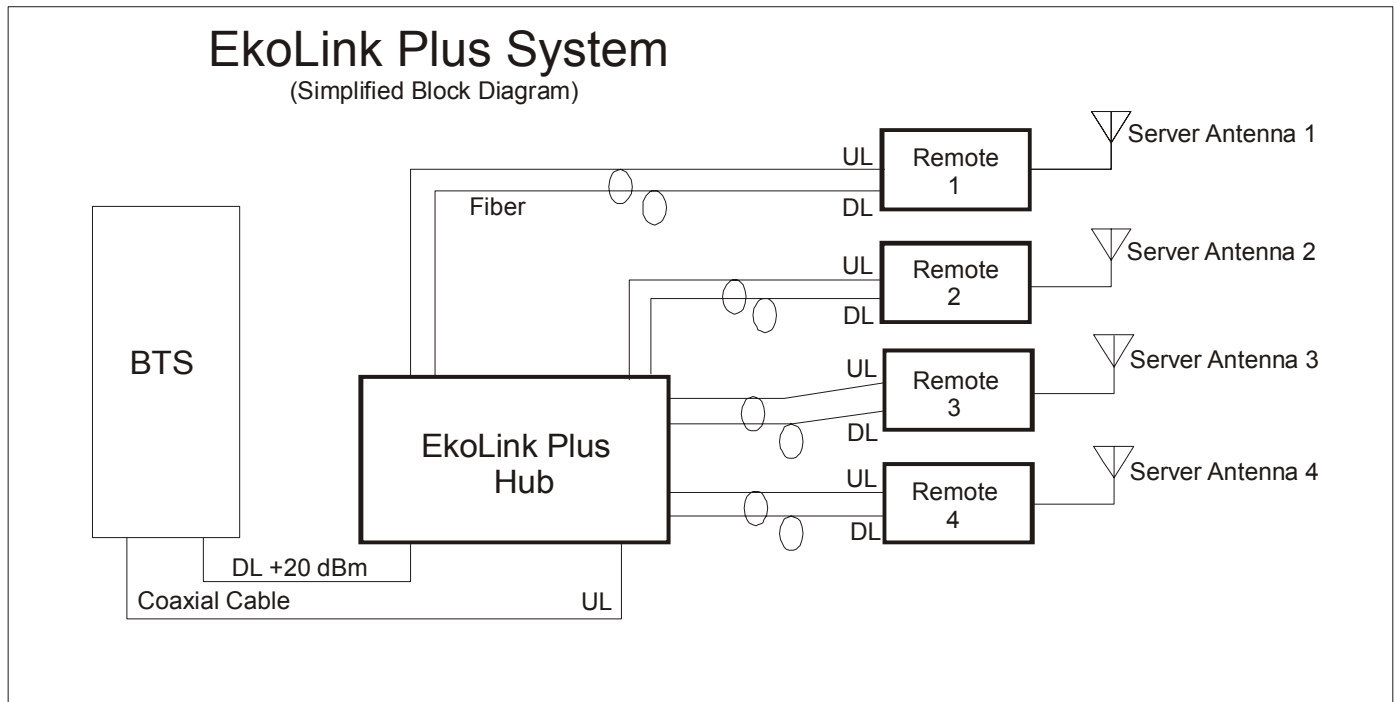

Figure 11: General Block Diagram of EkoLink Plus System

Figure 12 below shows a block diagram of the hub unit, and Figure 13 shows the remote unit block diagram.

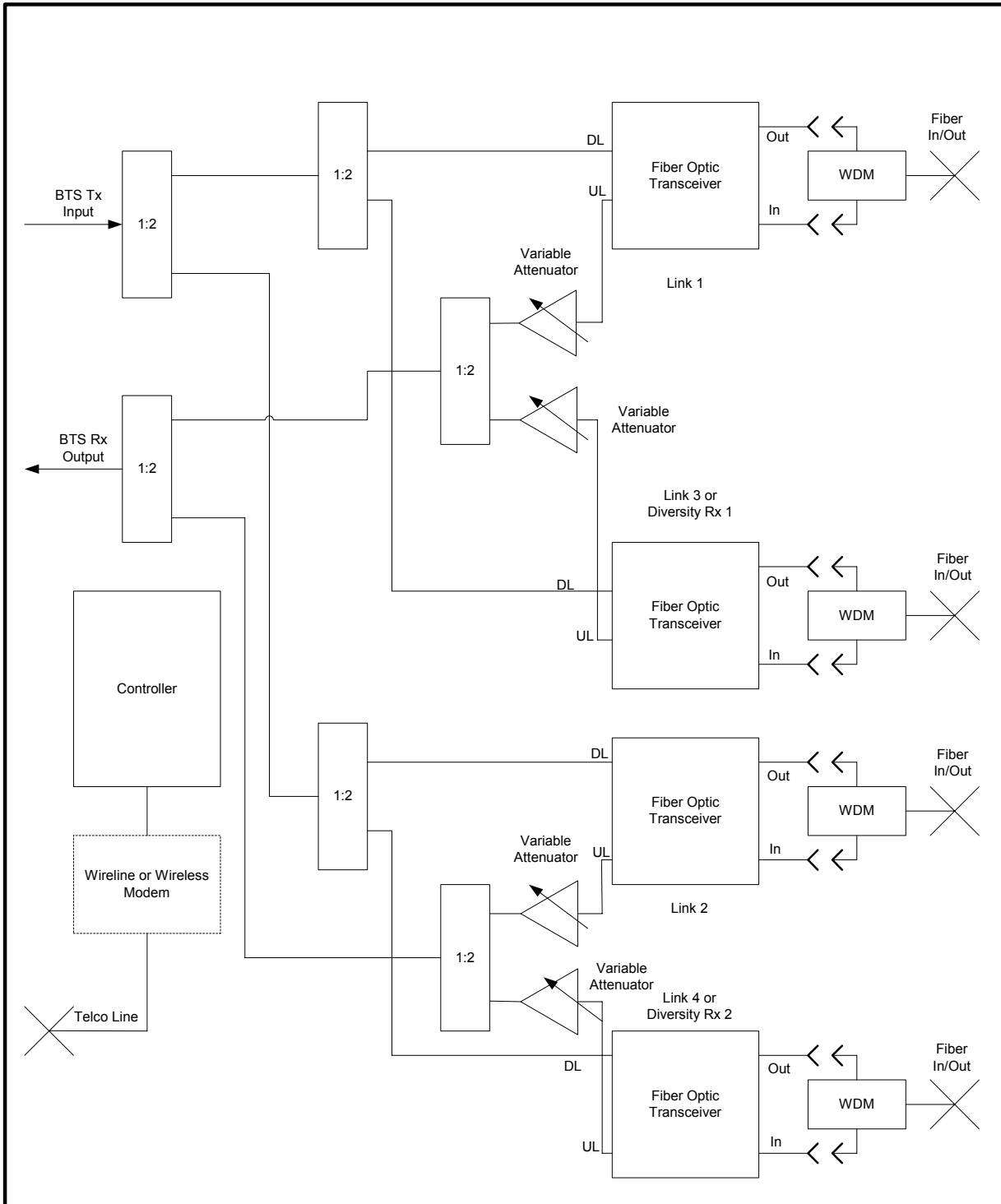

Figure 12: Block Diagram of EkoLink Plus Hub

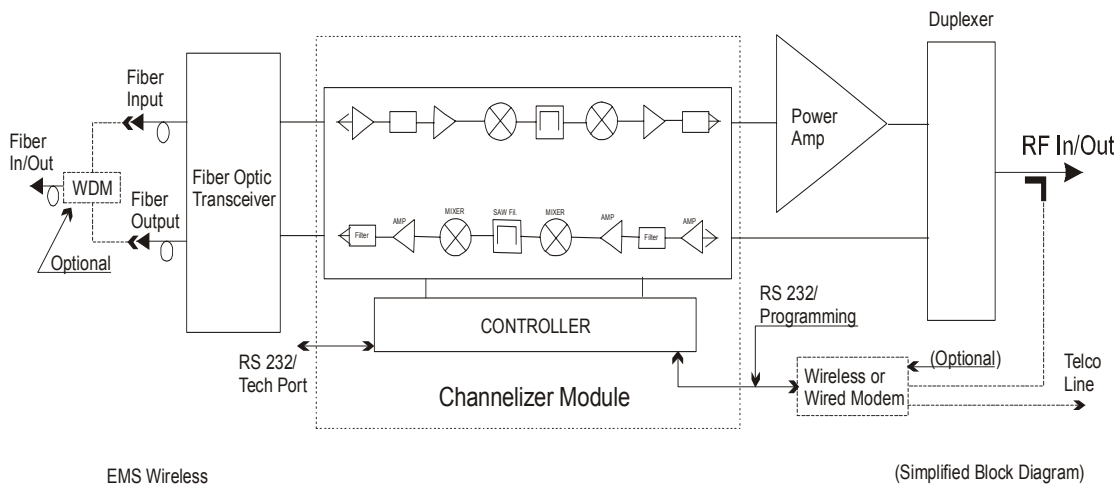

Figure 13: EkoLink Plus Remote Unit Block Diagram

5.1 Remote Unit

5.1.1 Channelizer Modules

Each path in the channelizer module consists of an LNA, a baseband down converter with SAW (Surface Acoustic Wave) filters, a baseband up converter, and a post amplifier. The module includes power level control functionality. The uplink path includes the power amplifier, while the downlink path has the power amplifier external to the channelizer.

5.1.2 Power Amplifier

The power amplifier is designed for an output power of 2 watts (+33 dBm), 4 watts (+36 dBm), 8 watts (+39 dBm) or 20 watts (+43 dBm) composite. The power amplifier is designed to meet industry standards for Adjacent Channel Power Ratio (ACPR) and spectral re-growth, and is compliant with all FCC required standards.

5.1.3 Power Supply Module

The power supply is designed for an input voltage of +26VDC or optionally 90 – 130 VAC, or 187 - 265 VAC.

5.1.4 Duplex Filter

The transmit and receive RF signals are combined with duplex filters operating in the desired frequency band. The filter consists of comb-line cavity bandpass filters, which provide excellent isolation against out-of-band signals.

5.1.5 Status and Control Module

The status and control module, contained within the channelizer, enables monitoring and control of the repeater. This module determines the status of the channel module and identifies failure conditions. When an alarm occurs, the module can send a message to a PC over a serial data link. The PC connection uses an RS232 serial port interface which connects to a laptop computer using Windows HyperTerminal or another similar terminal emulation program. Also, the status and control module sends and receives channel and amplification data on the addressed channel module when connected to a cellular modem.

Monitoring and control is possible through the MirrorCell Unit Manager (MUM) using a wireless or wired modem connection. The MUM is not accessible with a direct hard-line (local) connection to the status and control module.

5.1.6 Interconnect Module

The Interconnect Module provides interface and power connection to all of the modules in the remote unit. The control module, located in the channelizer, monitors each of the major modules by monitoring status and control lines distributed through the interface module. DC levels required by the channelizer are also regulated on the interconnect module and distributed to the channelizer.

5.1.7 Fiber Optic Transceiver

The Fiber Optic Transceiver modulates or demodulates the RF signal from the optical signal and provides interconnection to the optical fiber. Interconnection is provided via the interconnect module with the control module located in the controller. The control module transmits alarm status to the Hub Unit by pulsing the laser. This is received at the Hub where the alarm status is displayed or is monitored on a remote computer.

5.2 Hub Unit

A block diagram of the hub unit is shown in Figure 12.

5.2.1 Hub Interface Module

The Hub Interface Module provides the RF interface control for the uplink path, control of the optical lasers for signaling the remote status, interface to the controller module and wireline modem, and relays for alarm and control status. In addition, the primary power conversion is done in the hub interface module to provide all of the required voltages from an input supply voltage of 24 VDC.

5.2.2 Fiber Optic Transceiver

The Fiber Optic Transceiver modulates or demodulates the RF signal to the optical signal and provide interconnection to the optical fiber. The control module transmits alarms and control information to the remote repeater unit by pulsing or turning off the laser. This, in turn, is received at the remote repeater detector which provides the desired alarm and or control command. The Hub can be equipped with up to four fiber optic transceivers to support four remotes or two remotes with diversity receive.

5.2.3 Hub Control Module

The Hub control module enables monitoring and control of the hub and repeater. This module determines the status of the hub and repeater and identifies failure conditions. When an alarm occurs, the module can send a message to a PC over a serial data link. The PC connection is through an RS232 serial interface to a laptop computer equipped with Windows HyperTerminal or a similar terminal emulation program. Also, the status and control module sends and receives channel and amplification data to a remote location when connected to a wireline or wireless modem.

Monitoring and control is possible through the MirrorCell Unit Manager (MUM) using a wireless or wired modem connection. The MUM is not accessible with a direct hard-line (local) connection to the status and control module.

5.2.4 Hub Power Supply Module (Optional)

The 115/230 VAC power supply module provides an output nominal voltage of 24VDC to the hub interface module when battery back up is not required.

6.0 EkoLink Plus Specifications

6.1 EkoLink Plus RF Specifications

The RF Specifications are shown in Table 2 below.

Table 2: EkoLink Plus RF Specifications

Parameters	Uplink	Downlink
PCS Bands:		
Band A	1850-1865 MHz	1930-1945 MHz
Band B	1870-1885 MHz	1950-1965 MHz
Band C	1895-1910 MHz	1975-1990 MHz
Band D	1865-1870 MHz	1945-1950 MHz
Band E	1885-1890 MHz	1965-1970 MHz
Band F	1890-1895 MHz	1970-1975 MHz
Cellular Bands:		
Cellular A	824 – 835 MHz	869 – 880 MHz
Cellular B	835 – 849 MHz	880 – 894 MHz
Cellular AE (Extended)	824 – 835/845 – 846.5	869-880/890 – 891.5
Cellular BE (Extended)	835 – 845/846.5-849.0	880-890/891.5-894
Cellular Full	824-849	869-894
Cellular Public Safety	821-824	866-869
Cellular SMR	806-821	851-866
SMR, Full	806-824	851-869
Maximum number of Sub-Bands	2	2
Output Power Limit (Composite)	N/A	
- 733, Single Carrier Power		+33 dBm (+0.5, -1 dB)
- 736, Single Carrier Power		+36 dBm (+0.5, -1 dB)
- 739, Single Carrier Power		+39 dBm (+0.5, -1 dB)
- 743, Single Carrier Power		+43 dBm (+0.5, -1 dB)
Number of Carriers	Single or Multiple	Single or Multiple
Interference Signal, No Desense	-35 dBm	
RF Input to repeater Maximum, No Damage	-10 dBm	+30 dBm
Noise Figure at Max Gain	≤ 6 dB	≤7.5 dB
C/N, Over Gain Range		≥55 dB
Gain at Minimum Attenuation	4 dB (± 2 dB)	19, 23 dB

Digital Attenuator Range	0 to 30 dB 1 dB steps (± .5 dB)	0 to 30 dB 1 dB steps (± .5 dB)
Intermodulation, Out of Band		≤ -13 dBm
Intermodulation, Out of Band	≤ -13 dBm	
Flatness	2 dB (p-p)	2 dB (p-p)
Gain Change over BW	± 2 dB	± 2 dB
Gain Change over temperature (-25 to 50 °C operating ambient temp.)	± 2 dB	± 2 dB
Return Loss (I/O)	> 14 dB	> 14 dB
Signal Electrical Delay, plus Fiber	3.0 μsec (Typical)	3.0 μsec (Typical)
Impedance	50 ohm	50 ohm
Optical Wavelength	1310 nm	1550 nm
Optical Path Loss Maximum	5 dB	5 dB

6.2 EkoLink Plus Mechanical Specifications – Remote

The Remote Mechanical Specifications are shown in Table 3 below.

Table 3: EkoLink Plus Remote Mechanical Specifications

Housing (W x H x D)	15.2 x 23 x 14.2 inches (61 x 38 x 35.6 cm)
RF Connectors	N Type/Female
Optical Connectors	FC/APC
Fiber Type	Single Mode
Weight	47 lbs (21.4 kg)
Housing Material	Aluminum
Primary Power	26VDC 115/230 VAC
Current Draw @ 27 VDC	
-739 (8 watts RF)	10.5 Amps @ 26 VDC
-743 (20 watts RF)	14.5 Amps @ 26 VDC
Connection Panel	Protected against unauthorized access
Color	Gray (painted)
Cooling	Convection/Forced Air Temperature Controlled

6.3 EkoLink Plus Mechanical Specifications – Hub

The EkoLink Plus Hub Mechanical Specifications are shown in Table 4 below.

Table 4: EkoLink Plus Hub Mechanical Specifications

Housing (W x H x D)	Rack Mount: 7 x 19 x 14 inches (17.8 x 48.3 x 35.6 cm) Wall Mount: 15.7 x 19.7 x 8.2 (39.9 x 50.0 x 20.8 cm)
RF Connectors	N(f)
Weight	32 lbs (14.5 kg)
Housing Material	Aluminum
Primary Power	+/- 27VDC, 0.7 Amps, standard 115/230 VAC, optionally
Color	Rack Mount: Black with white front panel (painted) Wall Mount: Gray
Cooling	Convection

6.4 EkoLink Plus Environmental Specifications

The EkoLink Plus Environmental Specifications are shown in Table 5 below.

Table 5: EkoLink Plus Environmental Specifications

EMI	Meets specifications for influx of an electromagnetic field of 10 V/m between 100 kHz – 1 GHz, excluding band of operation
Operating Temperature	-25 to 50° C. Also conforms to Bellcore specification GR-63-CORE, section 5.1.2
Storage Temperature	-40 to 75° C
Weather Resistance	Enclosure: NEMA 4 rated
Shipping	Conforms to Bellcore specification GR-63-CORE, sections 5.3 and 5.4.3

7.0 Detailed Software Commands

7.1 General

The Channelizer Module is equipped with a status and control system, which allows the monitoring and control of various parameters such as channel number, attenuation, temperature, status of door, etc., either with a local serial port/computer connection or via the MirrorCell Unit Manager (MUM). The communication interface between the computer and the control module is set up as a self-explanatory menu for simple manual control and monitoring. This way, the parameters can be easily read off of and set up from the display.

Note: The Usernames and Passwords should be changed during installation.

7.2 Software Command Set

A complete list of the manual software commands is shown in Table 6 below.

Table 6: Manual Software Command List

Command	Range	Example	Description
General Commands:			
GET PASSWORD			Displays current Username and Password settings.
NEED UPDATES			Can be used to retrieve information from the MUM
RESTART			Allows the unit to re-initiate the automatic software set-up sequence.
INIT232			Initializes both serial ports of the Channelizer.
GET FAT			Displays all attenuation and allocation thereof.
STATUS			Displays Status Screen.
STAT			Displays Status Screen.
HANGUP			Causes the RS232 port to sent ATH to the modem.
LIST ALARMS			List alarms and if they are

			currently active (able to report alarm state)
ALARMS			Lists current alarms in alarm state.
ALARM#			Displays a single alarm's parameters.
EXIT			Logs the user out.
MENU			Displays a menu of commands.
MODEM			Displays settings related to modem and reporting alarms.
GET LOG			
Help Commands:			
HELP			Displays Help screen.
HELP ALARM			Displays Help screen for alarms
HELP MODEM			Displays Help screen for modem and reporting.
HELP MENU			Displays Help screen for Menus.
HELP PASS			Displays Help screen for passwords.
HELP SET			Displays Help screen for SET commands.
SET Commands			
UNTNUMBER	Up to 19 alphanumerics	SET UNTNUMBER 770582	The unit's phone number (USED by MUM for identification).
MEMNUMBER	Up to 19 alphanumerics	SET MEMNUMBER 770582	The number the repeater will dial to report to the MUM an alarm or heartbeat.
UL OFFSET	-10 to 16	SET UL OFFSET -5	Allows the user to add an offset from the factory setting of the uplink gain in dB.
HB PERIOD	0 to 9999	SET HB PERIOD 720	Set the period in minutes the unit expects to have the

			heartbeat message either transmitted or received.
ALRM RTRY	0 to 100	SET ALRM RTRY 3	The number of time the unit will attempt to retry to report an alarm via modem.
ALRM INTV	0 to 999	SET ALRM INTV 10	Time between re-try attempts in minutes.
PROTOCOL	CDMA, GSM, OTHER	SET PROTOCOL CDMA	Protocol setting for repeater.
LZR RPRT	ON or OFF	SET LZR RPRT OFF	Off temporarily disables Laser Reporting, forcing the laser on until user exits or turns back on.
DLPOWER	20 to 38 (PEAK -1)	SET DLPOWER 37	Attempts to set Downlink composite output power to level (dBm). Only works within usable attenuation.
DL ATTN	0 to 30	SET DL ATTN 2	Allows the user to directly set the attenuation for the Downlink. CAUTION: Use the SET DLPOWER command for correct system functionality.
UL ATTN	0 to 30		Allows the user to directly set the attenuation for the Uplink. Use with CAUTION.
DL FREQ 1	1920 – 1990	SET DL FREQ 1 1937.5	Center frequency of the downlink filter.
UP FREQ 1	1800 – 1920	SET UL FREQ 1857.5	Center frequency of the uplink filter.
REPORT	OFF LASER MODEM BOTH	SET REPORT LASER	Determines how the remote unit will report an alarm: OFF = no report will be sent. LASER = Unit will ONLY report to Hub unit via Laser Pulses. MODEM = Unit will ONLY report to MUM using

			Modem dialing MEMNUMBER. BOTH = Remote unit will use both methods to report alarm.
PEAK	20 - 39	SET PEAK 36	Allows the user to set a LOWER peak output power than the factory setting.
ALARM #	ON or OFF	SET ALARM 2 OFF	If alarm is turned off, unit will not check for specific alarm condition.
DESIG #	0 - 3	SET DESIG 2 3	Change the designation of alarm #. Determines the specific alarm's value: 0 = Non-reporting 1 = Minor 2 = Major 3 = Critical
PWD #	8 alphanumerics	SET PWD 1 1Passwr	CASE SENSITIVE and can only be used by User ID1 and 2.
UID #	8 alphanumerics	SET UID 1 1UserNam	CASE SENSITIVE and can only be used by User ID1 and 2.
DT	xx/xx/xx	SET DT 12/31/02	Date in month/day/year format.
TM	xx:xx:xx	SET TM 16:33:00	Time in 24 hour format.
ID	Up to 19 alphanumerics	SET ID unit1location	User defined name or location of repeater; seen at MUM also.

Note: The SET UL and DL ATTN commands override the auto setup feature and allows the repeater to be set up outside of the RF detected power range of the repeater. Peak power limit will still function properly at the lowest usable level of detection, 18 dBm typical. User may wish to disable down link power detect alarm which will be on constantly due to no RF detected.

The RF detector typically has a dynamic range of detection of 23 dB and is calibrated at the factory for a RF power range of 17 to 40 dBm for the 8 watt unit option. The software look up table for the RF detector gives the unit a very accurate means of measuring average RF output power, typically +/-1 dB across the power range. Greatest accuracy is in the higher 10 dB of the power ranges. For example, option 739 would have the greatest accuracy in the +30 to +40 dBm region.

Command Examples

```
>set ul offset 2
>set dlpower 34
>set protocol CDMA
>set peak 37
>set PWD2 pass2
>set UID2 user2
>set dt 20/02/01
>set dt 02/20/01 Date set.
>set tm 11:47:00 Time set.
>set id unit123
>set memnumber 9876543211
>set untnumber 1234567890
>set report on
>set alarm 1 off
>set hb period 21
>set alrm rtry 2
>set alrm intv 5
```

7.3 Communication via the MirrorCell Unit Manager

To establish a connection to the repeater, follow the instructions contained in the MirrorCell Element Manager User's Guide. To enable the repeater to dial into the MUM to report ALARMS three command settings must be made.

1. **SET UNTNUMBER** – tells the repeater the phone number of the cell phone assigned to it
2. **SET MEMNUMBER** – Tells the repeater what number to call when an alarm has been triggered
3. **SET REPORT ON** – Tells the repeater that it is ok to report alarms when they occur

ALL setting commands can be administered by the MUM.

Appendix A: Installing the Wireless Modem into an EkoLink Plus

Items Needed:

- Wireless Modem
- Modem Interface cable
- Coaxial cable
- EkoLink Plus Repeater

Steps:

1. Remove interface from packaging material.
2. Plug DB9 Female connector into DB9 Male found on the Interface Module.
3. Connect the coaxial cable to the wireless modem and the other end to the the uplink duplexer coupling port
4. Plug modem interface cable into wireless modem.
5. Turn on modem. (The modem will be powered by the EkoLink Plus power supply and will supply charging power to the modem battery if applicatble through the interface cable as long as there is power to the power supply.)
6. Mount the modem in the designate location.
7. Power Cycle the EkoLink Plus.

Appendix B: HyperTerminal Configuration

HyperTerminal may be used for terminal emulation when using remote control of the repeater. Use the following steps for setting up HyperTerminal.

1. In the Start menu, open the Programs folder. Go to the Accessories folder in the Programs folder.
2. Choose Hyper-terminal. In that folder, choose HyperTerminal.
3. A dialog box will ask you to name the session. Use any name you choose. Select the icon showing the two telephones. See Figure B-1.

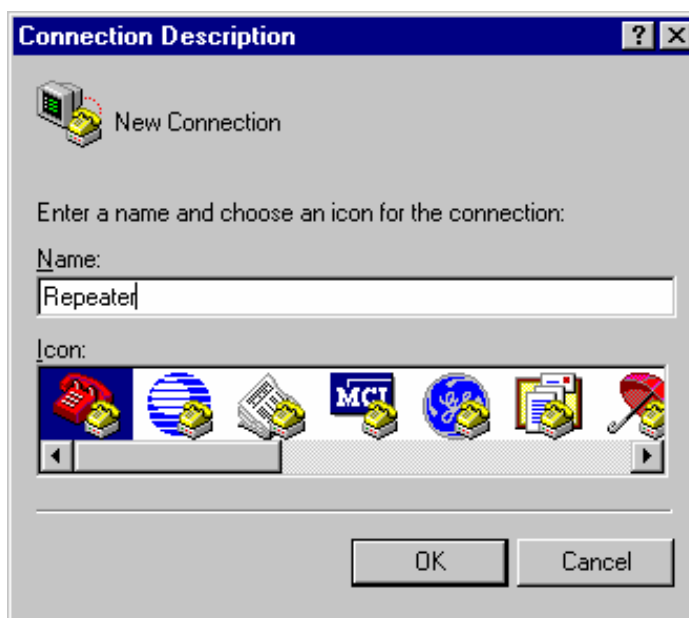

Figure B-1: Connection Description in HyperTerminal

4. For a direct connection to the repeater, choose “Direct to Com X” in the drop down box. See Figure B-2.



Figure B-2: HyperTerminal Screen for Direct Connection

For remote connection via modem, enter the number you wish to dial and choose to connect using “Standard Modem” as in Figure B-3.



Figure B-3: HyperTerminal Screen for Modem Connection

5. After clicking OK, you will need to choose “Port Settings”, as shown in Figure B-4. Select:

- Bits per Second: 9600
- Data bits: 8
- Parity: None
- Stop bits: 1

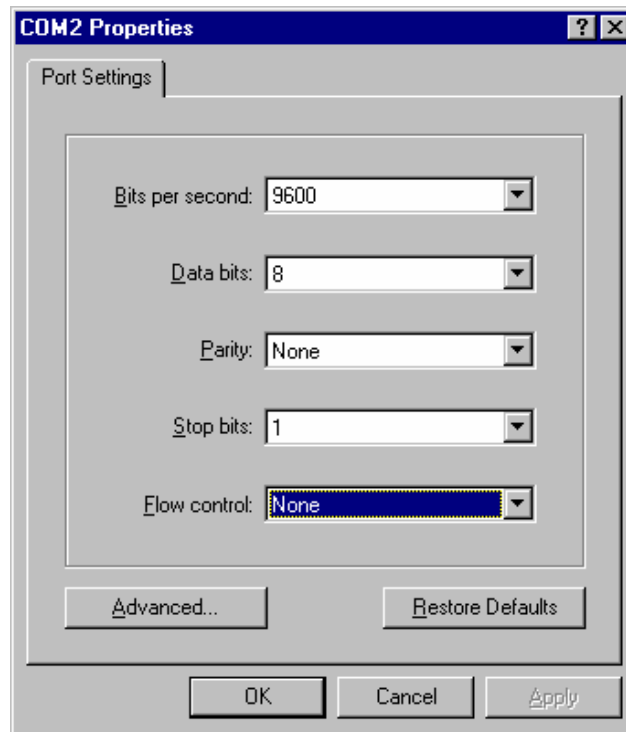

Figure B-4: Port Settings for Direct Connection and Remote Connection

The port settings will be the same for direct connection and remote connection. For a direct connection to the repeater, make sure flow control is set to “None.”