

Elec-Tech International Co., Ltd.

Product Instruction Manual

500W

Product Name: LED Grow Light

Model No.: 55403161

Manufacturer: Elec-Tech International Co., Ltd.

Address: No. 1 Jinfeng Road, Tangjiawan Town, Xiangzhou Dist, Zhuhai City, Guangdong Province,
China

Tel: 0756-3390990

Fax: 0756-3390778

Web: www.etissl.com.cn

Content

1. ProductIntroduction-----	3
1. 1 ProductDescription -----	3
1. 2 SchematicDiagram-----	3
2. ProductFeature-----	2
2. 1 Productcharacteristic -----	2
2. 2 Specification-----	3
2. 3 LightDistribution-----	4
3. Methodofapplication-----	4-7
4. Function keys Instruction-----	7
5. Controler pairing instruction-----	8-10
6. MaintenanceInstruction-----	10
7. Environmentalrequirement-----	11
8. Productcarriedstandard-----	11
9. Packageinstruction -----	11

1. Product Introduction

1.1. Product Description

- 1 Out Size: 700x350x138mm;
- 2
- 3 Frame:AL+ABS , Drive box:SPCC Powderspray, lamp cover:Tempered glass
- 4 built-in drive drive box
- 5 Radiating System: AL+Air fan
- 6 Samsung-LED-2835; OSRAM-LED-3030-Red; OSRAM-LED-3030-Blue

1.2.Product schematic diagram:

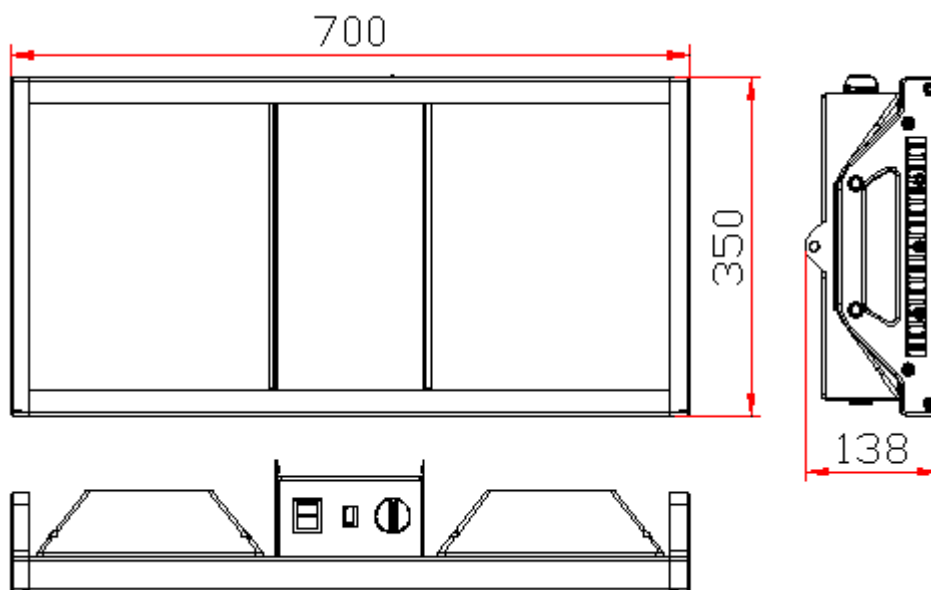

2. Product Features:

2.1. Product characteristics :

- a. Long lifetime (above 50,000hrs) ;
- b. High efficiency, energy saving,
- c. Promote the growth and development of plants, increase the production and income of agricultural industry, and advance the time of agricultural products market; It is suitable for planting fields such as planting and lighting in agricultural greenhouses, artificial solar light source in plant factories, etc.

2.2 Specification

Item/	Parameter
Electronic ratings	
WRatedPower/W	500W
VRatedInputvoltage/V	AC120-277V
HzFrequency/Hz	60Hz
%RatedPowerefficiency	85%
(PF) RatedPowerFactor	0.95
ARatedInputcurrent/A	4.15A
RatedI-THD	<20%
Photometric ratings	
LEDtype/Qty.	Samsung-2835/1W/280PCS Osram-3030-R/3W/84PCS Osram-3030-B/3W/60PCS
/PPF	800 umol/s
	Red/Blue/5000K
BeamAngle	≥100
Physical information	
Material	PC+SPCC+AL
operatingtemperature	-0~45℃
storagetemperature	-10~50℃
IPrating	IP20
(L×W×H)/mmLuminairedimension(L×W×H)/mm	700x350x138
gNetweight	13980 g
hrsLifetime/hrs	50000h

3 Installation Instructions

Hanging Mount

3.1 Attached two rope hangers to the ceiling or the structure that can support the weight of grow light plus some extra for power cords and rope hanger, etc.

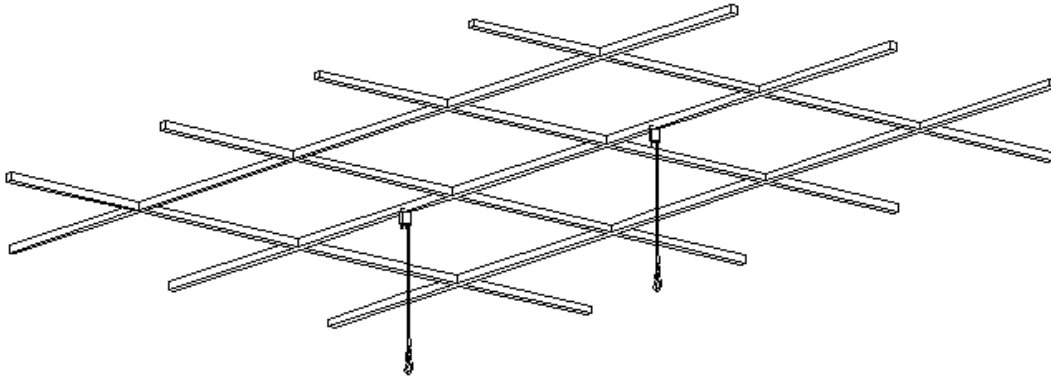

3.2 Place the provided V type hook over the hook of each rope hanger. Ensure both end of rope hanger are secure.

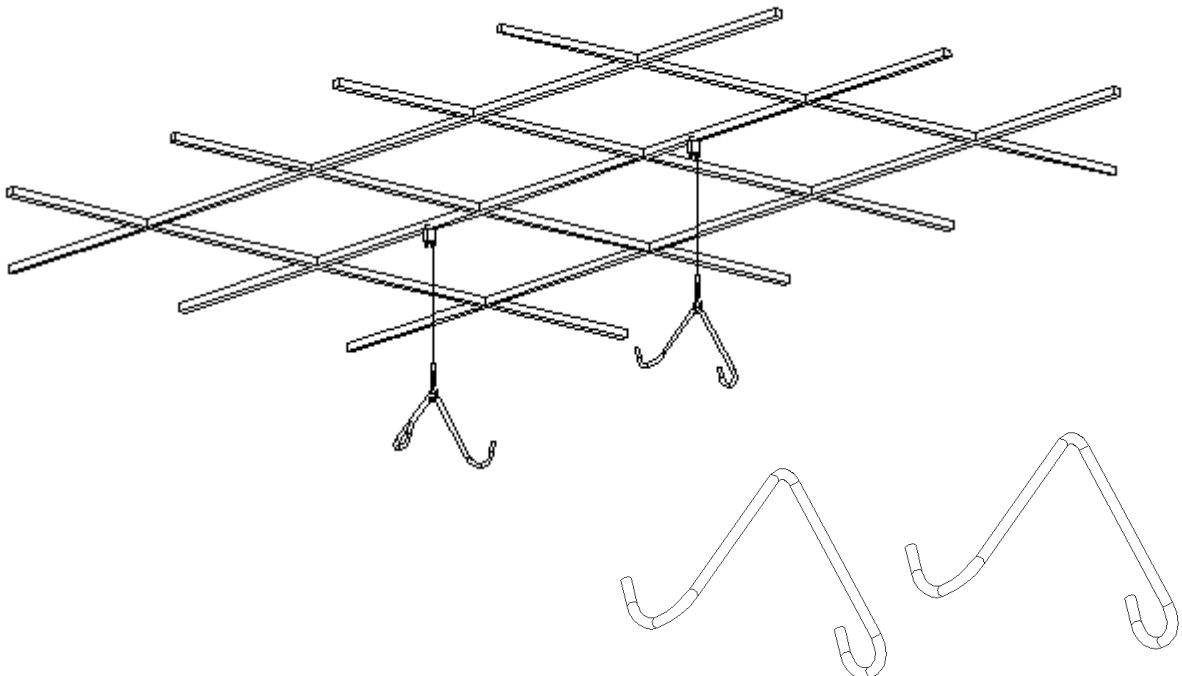

3.3 Hold the fixture body by hands, and hang the fixture body by placing one V type hook over each hole on both side of the fixture, adjust the rope hanger to level light.

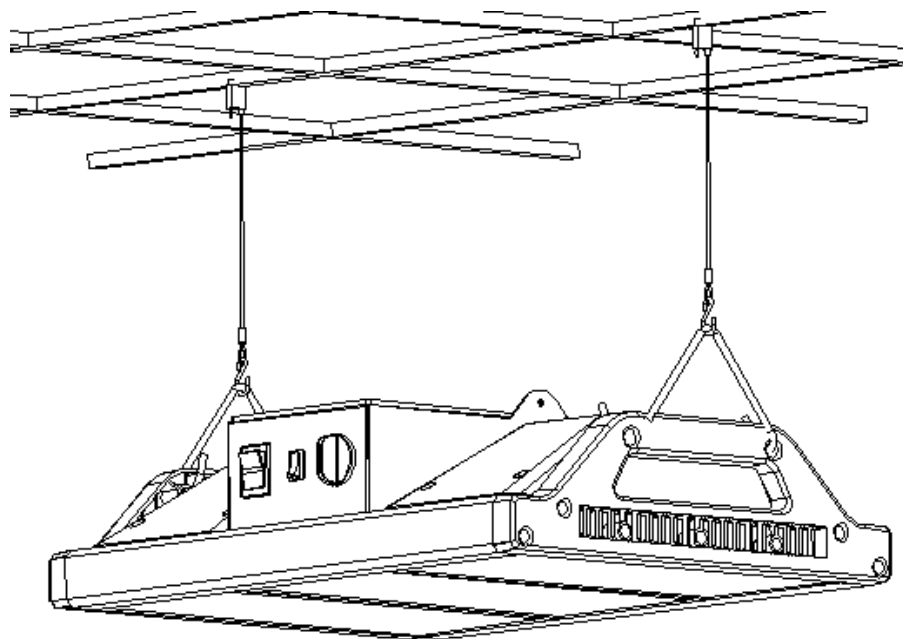
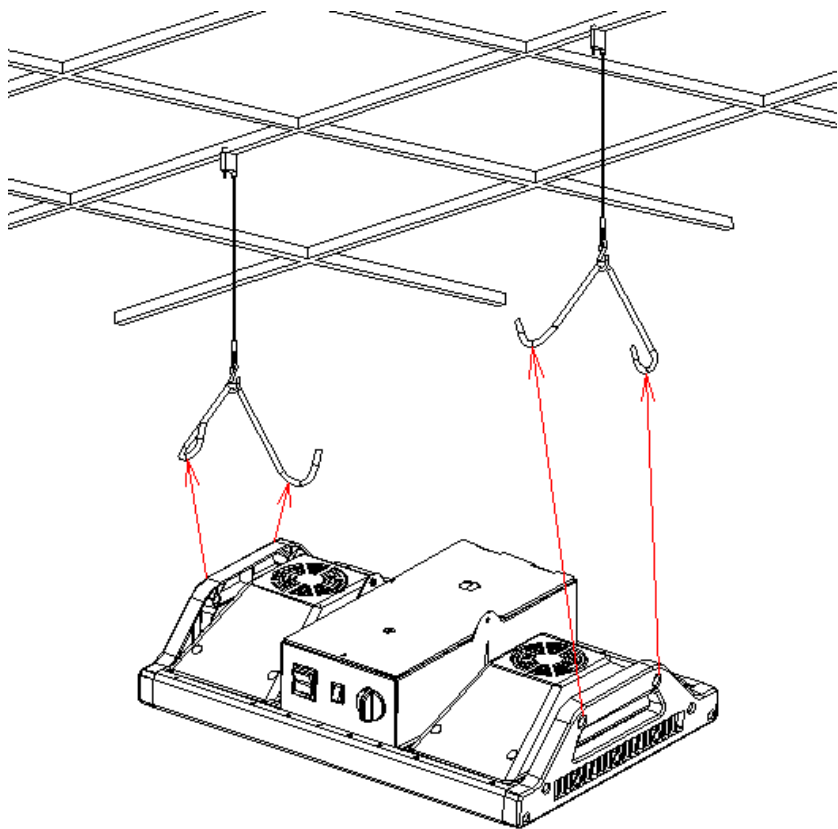

3.4 Insert one end of the provided power cord into to back of the fixture, and plug the other end of power cord into an electrical outlet. Press the “NO” button to activate the fixture.

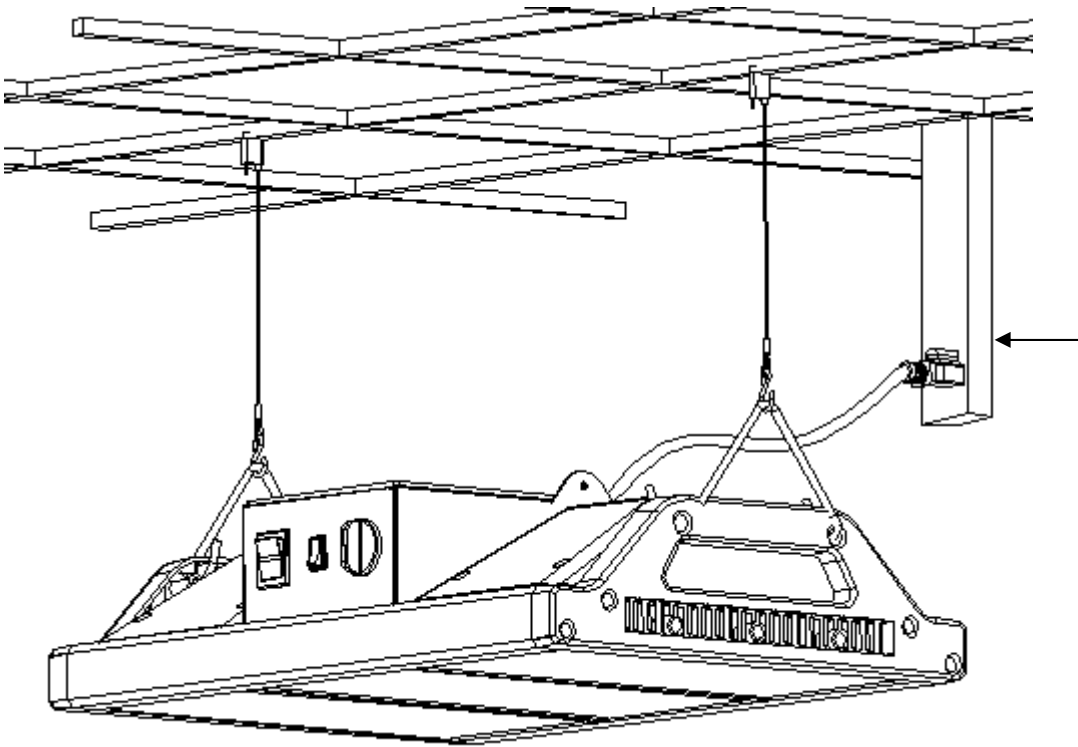

4. Operation Instruction for Control Panel Button and Knob on The Fixture

4.1. (Power Switch, “I/O”button, “I”represents power on , “O” represents power off)

4.2. (Spectrum Switch, “I/O/II”button, “I”represents full spectrum, “O”represents “Flower” spectrum, “II”represents “Veg” spectrum)

4.3.(Timer knob, spin the knob pointing to the desired position, then it starts the timer: “OFF”represents timer is off; “2Hs”represents light will be off in 2 hours; “4Hs” represents light will be off in 4 hours; “6Hs” represents light will be off in 6 hours; “8Hs” represents light will be off in 8 hours.)

5. (Guideline to remote controller)



(ON/OFF Button: When light is on press this button, the light will be off; when light is off press ON/OFF button the light will be on.)



(Select ALL button: Press this button, all the light will be on.)



(Press Red- button, red light reduces.)



(Press Red+ button, red light increases.)



(Press Blue- button, blue light reduces.)



(Press Blue+ button, blue light increases.)



(Press White- button, white- light reduces.)

White+ (Press White+ button, white+ light increases.)

Previous (Previous represents select the previous light.)

Next (Next represents select the next light.)

Group1 (Group1: When a grow light is selected, within 5 seconds press this button in short time, this grow light will be added to group1. The light flash indicates the grow light is added successfully.)

Group2 (Group2: When a grow light is selected, within 5 seconds press this button in short time, this grow light will be added to group2. The light flash indicates the grow light is added successfully.)

Group3 (Group3: When a grow light is selected, within 5 seconds press this button in short time, this grow light will be added to group3. The light flash indicates the grow light is added successfully.)

Group4 (Group4: When a grow light is selected, within 5 seconds press this button in short time, this grow light will be added to group4. The light flash indicates the grow light is added successfully.)

Pairing (Pair the grow light to remote controller: Press Pairing button when the fixture is power on in 60s, the grow light will flash to indicate the fixture is connected.)

Delete (Delete button: delete the connection with grow light. When grow light is connected, press this button, the remote controller disconnect with the fixture.)

My Favor1 (My favor1: Save the current color combination by pressing this button for long time about 4s; display the saved color combination by pressing this button in short time.)

My Favor2 (My favor2: Save the current color combination by pressing this button for long time about 4s; display the saved color combination by pressing this button in short time.)

My Favor3 (My favor3: Save the current color combination by pressing this button for long time about 4s; display the saved color combination by pressing this button in short time.)

My Favor4 (My favor4: Save the current color combination by pressing this button for long time about 4s; display the saved color combination by pressing this button in short time.)

Grow Mode (Grow Mode: Switch the grow mode: Flower, Veg, Full spec, White. Press the button in short time one grow mode will switch.)

Timer

(Timer: Press the button in short time lighting time will switch: 0h, 2h,4h,6h,8h, total five kind of light time. When lighting time is over, the light goes off, and the light on/off cycle is 24 hours.)

Pairing

(Pair the grow light to remote controller: When the fixture is power on within 60s, switch to “remote control” mode ,

press Paring button, the grow light will flash to indicate the fixture is connected. Grow light is controlled by pressing the -/+ and on/off buttons on the remote controller. The light changes to indicate the grow light is controlled successfully.)

Delete

(Delete connection: Select the grow light which is needed to be deleted by pressing Previous/Next Button, within 5 seconds, press Delete button, the light flash three times represents disconnection is successful. Once the selected grow light is deleted, this grow light will not be controlled any more.)

(Group Set Up: Select the grow light which is needed to be deleted by pressing Previous/Next Button, within 5 seconds, press any one of the buttons Group1, Group2,Group3, Group4, then the selected grow light will be group into the related group.)

(Group Control: Press any one of the buttons Group1, Group2,Group3, Group4 or ALL button, then press +/-、ON/OFF button, the group of grow lights can be controllerd. The light changes to indicate the grow light is controlled successfully.)

(Notice: Above operation is based on “remote control” mode. The grow light can be controller when it is in “remote control” mode. When timer points “OFF” mode, the timer on the remote controller can be set up.)

6. Maintenance instruction

6.1 Do Not use volatile solvent such as alcohol to clean the troffer.

6.2 Use soft cotton cloth with suds to clean the troffer .

6.3 Non-professional Do not attempt to take apart and repair the troffer .

6.4 Please use the constant-current driver exclusively adaptive to the troffer, do not change the driver without permission .

7. Environment requirement

Operating temperature : -10~40℃; Storage temperature : -20~50℃。

8. Product carried standard UL-1598/UL8750

9. Package Instruction

9.1 Packing Specification

9.2 Package list

Package size	
Lamp Qty./box	1 PCS
Net weight	13.98 Kgs
Gross weight	14.5 Kgs

Item	Qty.
Grow lamp	1
Instruction manual	1
Pothead	2
Power Line	1

FCC STATEMENT

1. This device complies with Part 15 of the FCC Rules.

Operation is subject to the following two conditions:

(1) This device may not cause harmful interference, and

(2) This device must accept any interference received, including interference that may cause undesired operation.

2. Changes or modifications not expressly approved by the party responsible for compliance could void the user's authority to operate the equipment.

FCC Radiation Exposure Statement:

This equipment complies with FCC radiation exposure limits set forth for an uncontrolled environment. In order to avoid the possibility of exceeding the FCC radio frequency exposure limits, Human proximity to the antenna shall not be less than 20cm (8 inches) during normal operation.

NOTE: This equipment has been tested and found to comply with the limits for a Class B digital, pursuant to Part 15 of the FCC Rules. These limits are designed to provide reasonable protection against harmful interference in a residential installation. This equipment generates, uses and can radiate radio frequency energy and, if not installed and used in accordance with the instructions, may cause harmful interference to radio communications. However, there is no guarantee that interference will not occur in a particular installation. If the equipment does cause harmful interference to radio or television reception, which can be determined by turning the equipment off and on, the user is encouraged to try to correct the interference by one or more of the following measures:

--- Reorient or relocate the receiving antenna.

--- Increase the separation between the equipment and receiver.

--- Connect the equipment into an outlet on a circuit different

from that to which the receiver is connected.

--- Consult the dealer or an experienced radio/ TV technician for help.