



BT-MSOII

Manual



Revision 1.2 – 2016/10/25



CONFIDENTIAL INFORMATION



Everint Co., Ltd..

List of Contents

1. General	3
1.1 Overview	3
1.2 Features.....	4
1.3 Application	4
1.4 Pin Configuration	5
1.5 Device Terminal Functions	6
1.6 Package Dimensions & Land Pattern	7
2. Characteristics	9
2.1 Electrical Characteristics	9
2.2 RF Characteristics.....	10
2.3 Antenna Characteristics	11
3. Terminal Description	12
3.1 UART Interface.....	12
3.2 SPI Interface (Debug only).....	12
3.3 I2C Interface	12
4. Reset, RST#	13

1. General

1.1 Overview

This specification covers Bluetooth module which complies with Bluetooth specification version 4.1 and integrates RF & Baseband controller in small package. This Module has deployed CSR's CSRB5341 chipset.

All detailed specification including pin outs and electrical specification may be changed without notice.

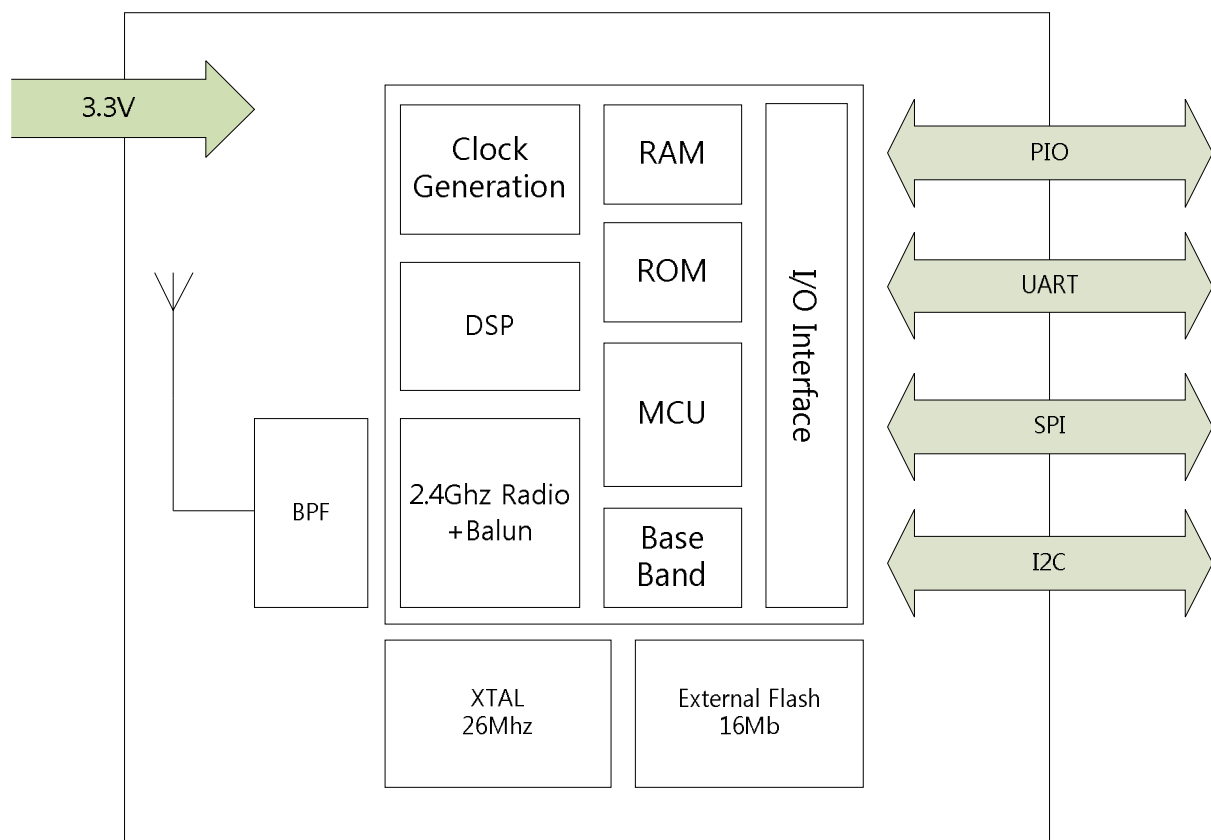

1.2 Features

- Bluetooth® v4.1 specification compliant
- Radio includes integrated balun and typical RF performance of 6 dBm transmit power and -87 dBm receive sensitivity
- 80 MHz RISC MCU
- Programmable DSP with 4K x 32-bit program
- Serial interfaces: UART , I²C and SPI (debug only)
- 4 general purpose PIOs.
- Integrated to 16Mbit external Flash memory
- Power-on-reset detects low supply voltage
- Competitive Size
BT-MSOII : 28mm x 18mm x 2.8mm : 44Pin
- Operating temperature range (MAX -20°C ~ 70°C)

1.3 Application

- Mobile Printer
- POS system

1.4 Pin Configuration

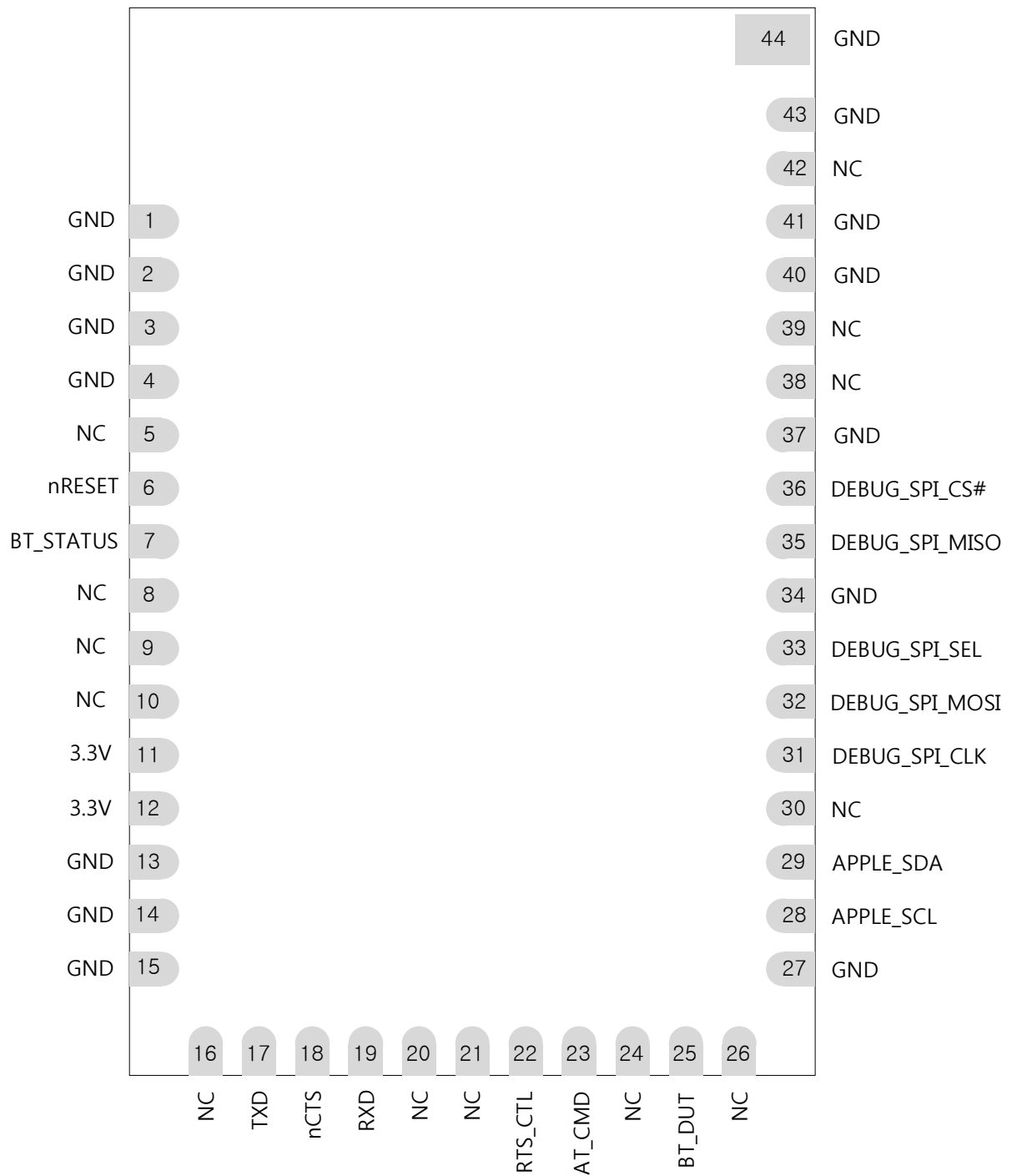

Pin Configuration (TOP VIEW)

1.5 Device Terminal Functions

	Function	Pin Name	Pin No.	Pin type	Description	Note
PIO	PIO[13]	BT_DUT	25	Bideirection, Weak Pull Down	BT DUT	
	PIO[14]	BT_STATUS	7		BT_STATUS	
	PIO[15]	AT_CMD	23		AT Command	
	PIO[16]	RTS_CTL	22		RTS Control	
I2C Interface	SDA	APPLE_SDA	29	Bideirection, Weak Pull Up	Apple MFi Chip Interface Data	
	SCL	APPLE_SCL	28		Apple MFi Chip Interface Clock	
SPI Interface	SPI_MISO	DEBUG_SPI_MISO	35	Output, Weak Pull Down	SPI Data Output	
	SPI_MOSI	DEBUG_SPI_MOSI	32	Input, Weak Pull Down	SPI Data Input	
	SPI_CS#	DEBUG_SPI_CS#	36	Input, Weak Pull Down	Chip Select Active Low	
	SPI_CLK	DEBUG_SPI_CLK	31	Input, Weak Pull Down	SPI Clock	
	SPI_SEL	DEBUG_SPI_SEL	33	Input, Pull Up	SPI Select	
UART Interface	UART_RX	RXD	19	Bidirection Weak Pull Down	UART Data Input	
	UART_TX	TXD	17		UART Data Output	
	UART_CTS	nCTS	18		UART Clear to Send Active Low	
Other Pins	3V3	3V3	11,12		Positive Power Supply	
	RESET	nRESET	6	Input, Strong Pull Up	Reset	
	GROUND	GND	1,2,3,4,13,14,15,27,34,37 40,41,43,44		Ground	
	NC	NC	5,8,9,10,16,20,21,24,26,30 38,39,42		Not Connect	

1.6 Package Dimensions & Land Pattern

- unit = mm
- General Tolerances = ± 0.2 mm

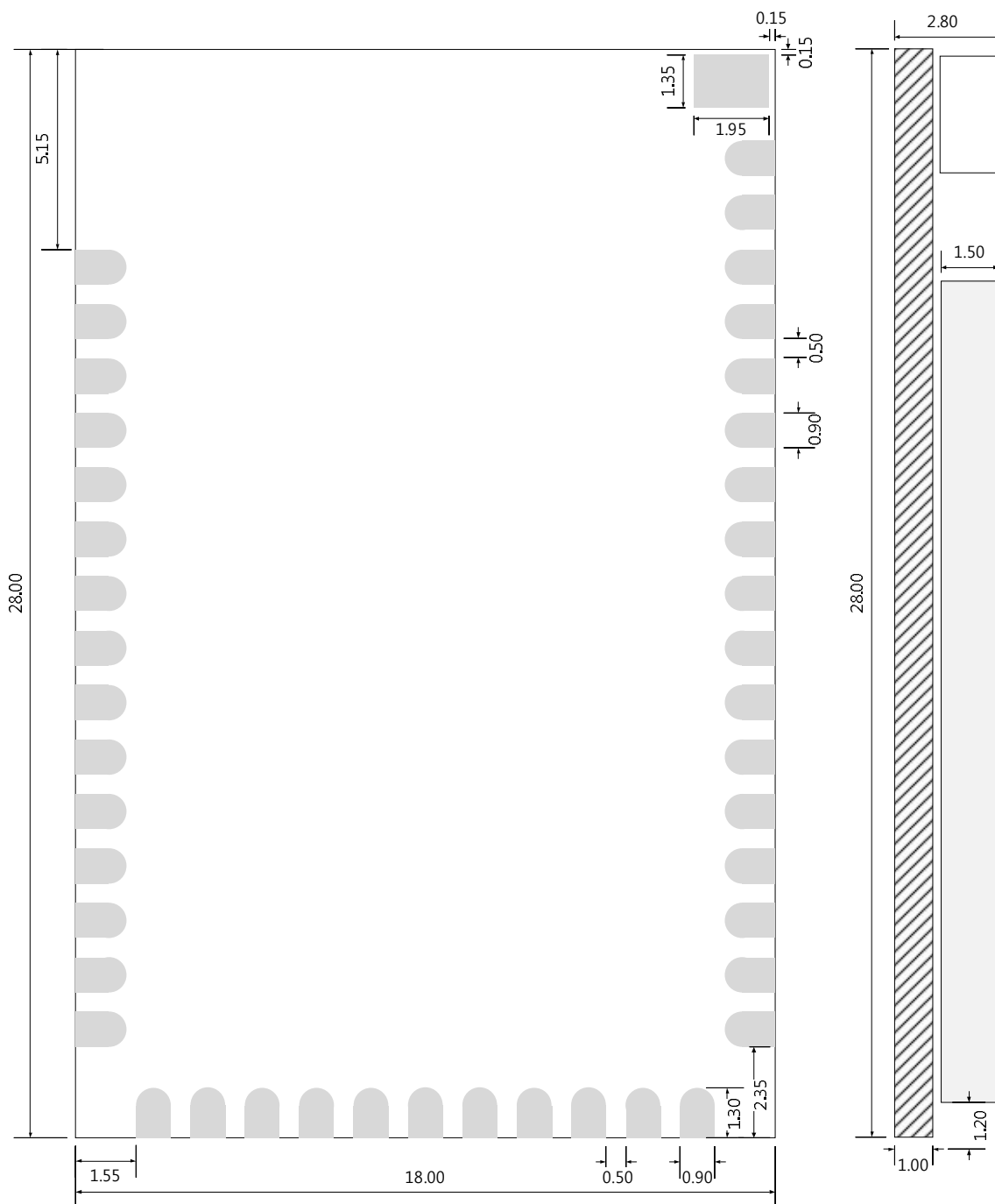

BT-MSOII Dimensions

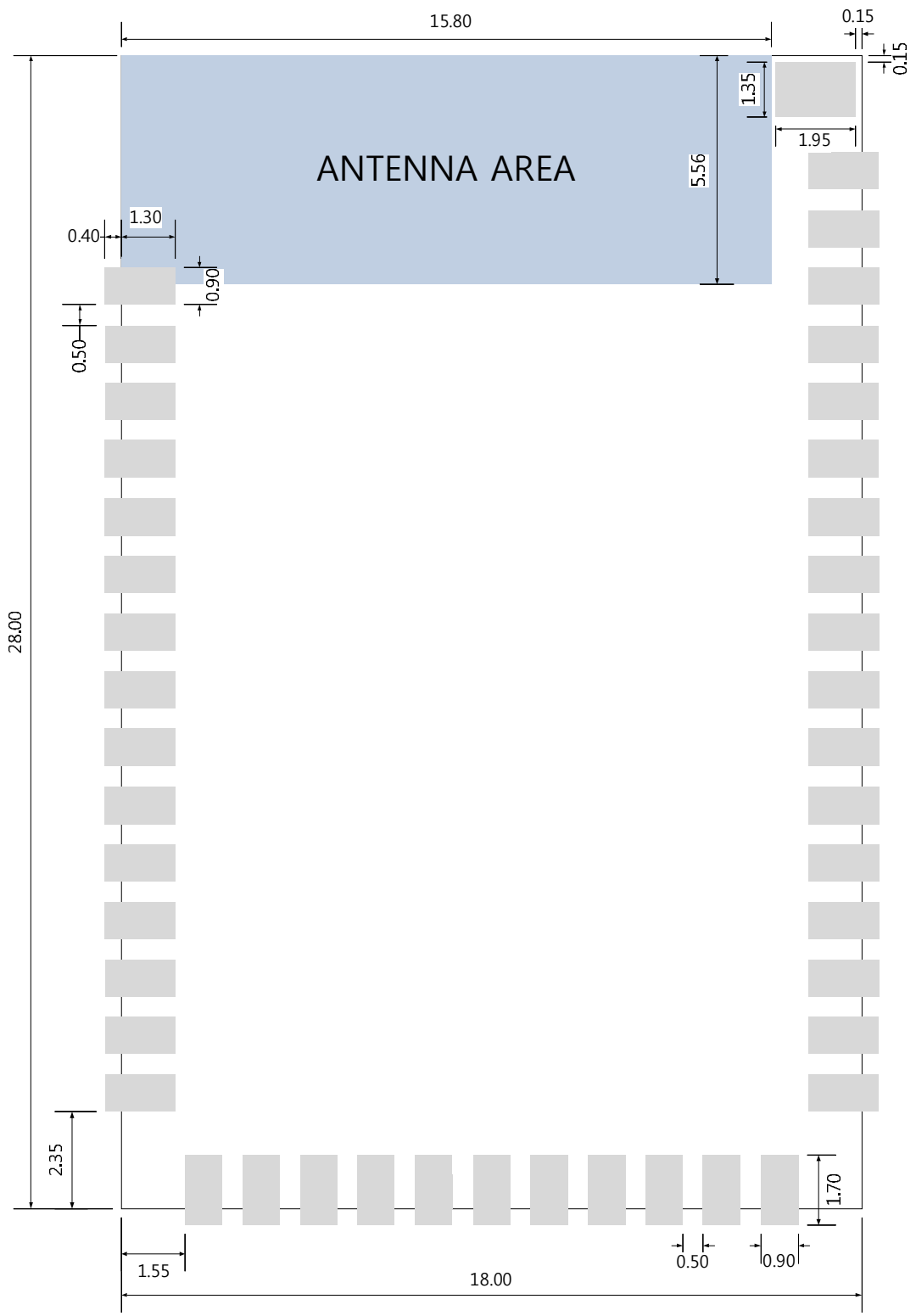

Land Pattern

2. Characteristics

2.1 Electrical Characteristics

■ Absolute Maximum Ratings

Rating	Min	Max	Unit
Storage Temperature range	-40	85	°C
VDD	-0.4	3.6	V
Other terminal voltages	VSS-0.4	VDD+0.4	V

■ Recommended Operating Conditions

Operating Condition	Min	Typ	Max	Unit
Operating Temperature range	-20	20	70	°C
VDD	2.5	3.3	3.6	V
Other terminal voltage	2.5	3.3	3.6	V

■ Current consumption

Classic (Test Condition : VDD =3.3V, Temp = 25°C, Sniff = 40ms)	Typ	Peak	Unit	
Standby current	-	5	mA	
Connected current	-	4	mA	
TX current with UART	-	9	23	mA
RX current with UART	-	9	19	mA
BLE (Test Condition : VDD =3.3V, Temp = 25°C, Sniff = 16.25ms)	Typ	Peak	Unit	
Standby current	-	6	mA	
Connected current	-	4	mA	
TX current with UART	-	7	27	mA
RX current with UART	-	4	20	mA

UART baud rate = 230,400bps

■ Digital Terminals

Input Voltage Levels	Min	Typ	Max	Unit
V _{IL} input logic level low	-0.4	-	0.25xVDD	V
V _{IH} input logic level high	0.7 x VDD	-	VDD+0.4	V
T _r /T _f	-	-	25	ns
Output Voltage Levels	Min	Typ	Max	Unit
V _{OL} output logic level low, I _{OL} = 4.0mA	-	-	0.4	V
V _{OH} output logic level high, I _{OH} = -4.0mA	0.75 x VDD	-	-	V
T _r /T _f	-	-	5	ns
Input and Tristate Currents	Min	Typ	Max	Unit
Strong pull-up	-150	-40	-10	µA
Strong pull-down	10	40	150	µA
Weak pull-up	-5	-1.0	-0.33	µA
Weak pull-down	0.33	1	5	µA
C _i Input Capacitance	1	-	5	pF
High impedance state (no pulls)	-0.1	0	0.1	µA

2.2 RF Characteristics

RF	Specification	Condition	Min	Typ	Max	Unit
Transmitter	Output transmit power	2.402	-	4.69	-	dB
		2.441	-	4.96	-	dB
		2.480	-	5.15	-	dB
	Transmit power density		-	-6.29	-	dBm
	Transmit power control	Pmin	-25.79	-	-	dBm
		Pst	3.88	4.81	-	dB
	Frequency Range		2401.515	-	2480.485	Mhz
	20dB bandwidth for modulation		-	925	-	Khz
	Adjacent channel transmit power	±2MHz	-	-22.4	-	dBm
		±3MHz	-	-48.09	-	dBm
		±4Mhz	-	-48.79	-	dBm
	Modulation characteristics	Δf1avg	-	165	-	Khz
		Δf2_pass_rate	-	100	-	%
		Δf2avg/Δf1avg	-	0.93	-	
	Intial carrier frequency tolerance	df0_avg	-	-13.7	-	Khz
Carrier frequency drift	One slot packet(DH1)	-	-4.7	-	KHz	
	Three slot packet(DH3)	-	-6.4	-	KHz	
	Five slot packet(DH5)	-	-6.4	-	KHz	
Receiver	Sensitivity at 0.1% BER for all basic rate packet types	2.402		-84.6	-	dBm
		2.441	-	-86.9	-	dBm
		2.480		-86.9	-	dBm
	Maximum input level		-20	-5	-	dBm

2.3 Antenna Characteristics

The antenna is monopole type of chip antenna. The antenna impedance matching is optimized for 1 mm ~ 2 mm mother board PCB thickness. The radiation pattern is impacted by the layout of the mother board. Typically the highest gain is towards GND plane and weakest gain away from the GND plane.

■ LOG, Smith Chart & VSWR

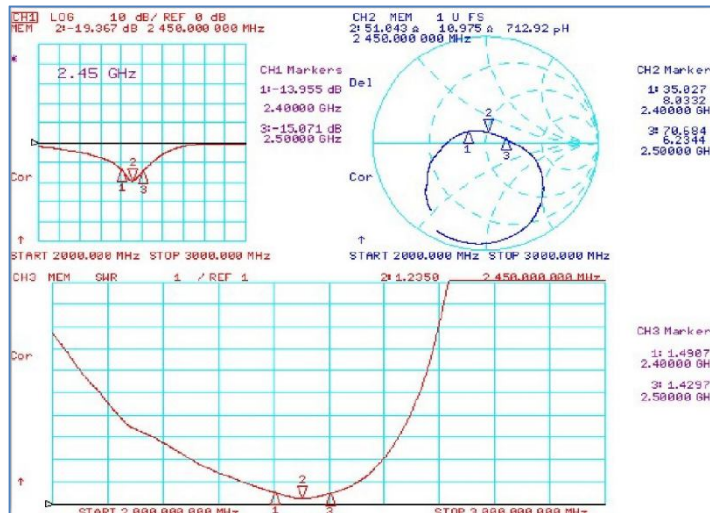

■ Radiation Gain

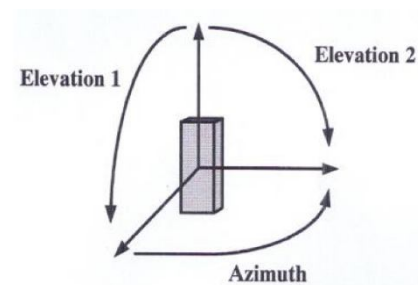
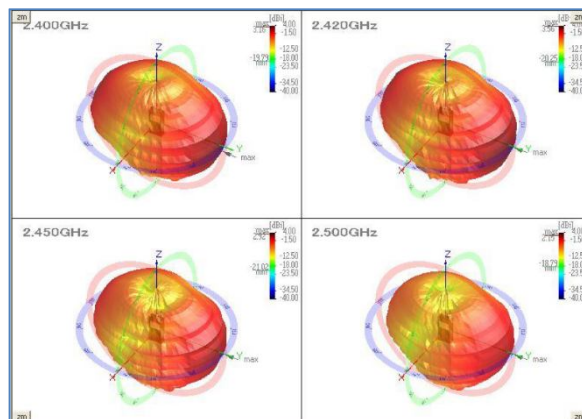

Freq(Mhz)	Efficiency(%)	Avg. Gain(dBi)	Peak Gain(dBi)
2400	55.26	-2.58	3.16
2420	56.16	-2.51	3.56
2450	45.52	-3.42	2.92
2500	37.27	-4.29	2.15

3. Terminal Description

3.1 UART Interface

This is a standard UART interface for communicating with other serial devices. BT-MSOII UART interface provides a simple mechanism for communicating with other serial devices using the RS-232 protocol.

When BT-MSOII is connected to another digital device, UART_RX and UART_TX transfer data between the 2 devices. The remaining a signal, UART_CTS implement optional RS232 hardware flow control

3.2 SPI Interface (Debug only)

BT-MSOII provides a debug SPI interface for programming, configuring and debugging the BT-MSOII. Access to this interface is required in production. Ensure the 4 SPI signals externally.

3.3 I2C Interface

BT-MSOII supports a firmware controlled I²C interface to communicate with external Device. The I²C timing is compliant with the Philips I²C Specification (100 kHz and 400 kHz).

4. Reset, RST#

BT-MSOII is reset from several sources:

- RST# pin
- Power-on reset
- UART break character

The RST# pin is an active low reset and is internally filtered using the internal low frequency clock oscillator. CSR recommends applying RST# for a period >5ms.

■ Notice

This device complies with Part 15 of the FCC Rules. Operation is subject to the following two conditions:

- (1) This device may not cause harmful interference, and
- (2) This device must accept any interference received, including interference that may cause undesired operation.

This device complies with Industry Canada's licence-exempt RSSs. Operation is subject to the following two conditions:

- (1) This device may not cause interference; and
- (2) This device must accept any interference, including interference that may cause undesired operation of the device

Le présent appareil est conforme aux CNR d'Industrie Canada applicables aux appareils radio exempts de licence. L'exploitation est autorisée aux deux conditions suivantes :

- (1) l'appareil ne doit pas produire de brouillage, et
- (2) l'utilisateur de l'appareil doit accepter tout brouillage radioélectrique subi, même si le brouillage est susceptible d'en compromettre le fonctionnement.

The module is limited to OEM installation ONLY.

OEM integrators are responsible for ensuring that the end-user has no manual instructions to remove or install module.

The module is limited to installation in mobile or fixed applications, according to Part 2.1091(b).

Separate approval is required for all other operating configurations, including portable configurations with respect to Part 2.1093 and different antenna configurations.

For a host manufacture's using a certified modular, if (1) the module's FCC ID is not visible when installed in the host, or (2) if the host is marketed so that end users do not have straightforward commonly used methods for access to remove the module so that the FCC ID of the module is visible; then an additional permanent label referring to the enclosed module: "**Contains Transmitter Module FCC ID: 2AKMF-BT-MSOII**" or "**Contains FCC ID: 2AKMF-BT-MSOII**" must be used. The host OEM user manual must also contain clear instructions on how end users can find and/or access the module and the FCC ID.

Canada certification label of a module shall be clearly visible at all times when installed in the host product; otherwise, the host product must be labelled to display the Canada certification number for the module, preceded by the word "Contains" or similar wording expressing the same meaning, as follows:

Contains IC : 22266-BTMSOII

■ Product Information

Model Number	BT-MSOII
Product Name	Bluetooth Module
Firmware Version	2.0.0

■ Antenna

The MT-MSOII Module has been designed to operate with the following antenna and gains. Use with other antenna types or with these antenna types at higher gains is strictly prohibited.

Type of Antenna	Gain (dBi)	Type of Connector
Chip Antenna	3.56	Permanent integral

■ Warning - U.S.A

i) Changes or modifications not expressly approved by the manufacturer could void the user's authority to operate the equipment.

ii) Caution: Exposure to Radio Frequency Radiation.
To comply with FCC RF exposure compliance requirements, a separation distance of at least 20 cm must be maintained between the antenna of this device and all persons.

Afin de se conformer aux exigences en matière d'exposition aux rayonnements radioélectriques, une distance de séparation d'au moins 20 cm doit être maintenue entre l'antenne de cet appareil et toutes les personnes.