

## 4. TROUBLESHOOTING

If you encounter one of the following problems with the PIRZB1-ECO, use the following solutions to resolve the problem:

Problem	Solution
Attempt to pair the sensor is unsuccessful.	Reset the detector to default mode and then set to pairing mode (see section 3.5).
The sensor and the Touchscreen (control panel) do not communicate.	Perform the signal strength testing procedure described in the control panel installation manual. Make sure that the signal is sufficient. If necessary, replace the sensor's battery.
The sensor sends a Low Battery indication.	To ensure continuous proper operation, replace the battery within two weeks of the first Low Battery indication.
Panel does not arm because of an unrecognized sensor malfunction.	Consult with your installer or system provider before you disable a zone. Disable the sensor zone (see the control panel user manual). Note that disabling a sensor zone lowers the overall security level of your system.

## 5. SPECIAL COMMENTS

Even the most sophisticated detectors can sometimes be defeated or may fail to warn due to: DC power failure / improper connection, malicious masking of the lens, tampering with the optical system, decreased sensitivity in ambient temperatures close to that of the human body and unexpected failure of a component part. The above list includes the most common reasons for failure to detect intrusion, but is by no means comprehensive. It is therefore recommended that the detector and the entire alarm system be checked weekly, to ensure proper performance. An alarm system should not be regarded as a substitute for insurance. Home and property owners or renters should be prudent enough to continue insuring their lives and property, even though they are protected by an alarm system.

## 6. COMPLIANCE WITH STANDARDS

FCC Statement: This equipment has been tested and found to comply with the limits for a Class B digital device, pursuant to Part 15 of the FCC Rules. These limits are designed to provide reasonable protection against harmful interference in a residential installation. This equipment generates, uses and can radiate radio frequency energy and, if not installed and used in accordance with the instructions, may cause harmful interference to radio communications. However, there is no guarantee that interference will not occur in a particular installation. If this equipment does cause harmful interference to radio or television reception, which can be determined by turning the equipment off and on, the user is encouraged to try to correct the interference by one of the following measures:

- Reorient or relocate the receiving antenna.
- Increase the separation between the equipment and receiver.
- Connect the equipment into an outlet on a circuit different from that to which the receiver is connected.
- Consult the dealer or an experienced radio/TV technician for help.

This device complies with Part 15 of the FCC Rules. Operation is subject to the following two conditions:

(1) This device may not cause harmful interference and (2) this device must accept any interference received, including interference that may cause undesired operation.

**Warning:** Changes or modifications not expressly approved by the Ecolink Intelligent Technology Inc. could void the user's authority to operate the equipment.

This device complies with Industry Canada license-exempt RSS standard(s). Operation is subject to the following two conditions: (1) this device may not cause interference, and (2) this device must accept any interference, including interference that may cause undesired operation of the device.

Cet appareil est conforme avec Industrie Canada exempts de licence standard RSS (s). Son fonctionnement est soumis aux deux conditions suivantes: (1) cet appareil ne doit pas provoquer d'interférences et (2) cet appareil doit accepter toute interférence, y compris celles pouvant causer un mauvais fonctionnement de l'appareil.

In accordance with FCC requirements of human exposure to radiofrequency fields, the radiating element shall be installed such that a minimum separation distance of 20 cm is maintained from the general population.

Conformément aux exigences d'Industrie Canada en matière d'exposition humaine aux champs de radiofréquences, l'élément rayonnant doit être installé de telle sorte qu'une distance minimale de 20 cm soit maintenue par rapport à la population générale.

FCC ID: XQC-PIRZB1ECO

IC ID: 9863B-PIRZB1ECO

Installation shall be done in accordance with the Standard for Installation and Classification of Burglar and Holdup Alarm Systems, UL 681.

# PIRZB1-ECO

Wireless Digital Pet Resistant PIR Detector

3<sup>rd</sup> Party Certifications: FCC, IC, ETL, ZigBee HA, iControl



Installation Instructions

## 1. INTRODUCTION

The PIRZB1-ECO pet resistant detector is a microprocessor-controlled wireless digital PIR detector supported by ZigBee Home Automation 1.2. The detector's features are as follows:

- A. Red LED
- B. Green LED
- C. Tamper Switch

Figure 1 - PIRZB1-ECO

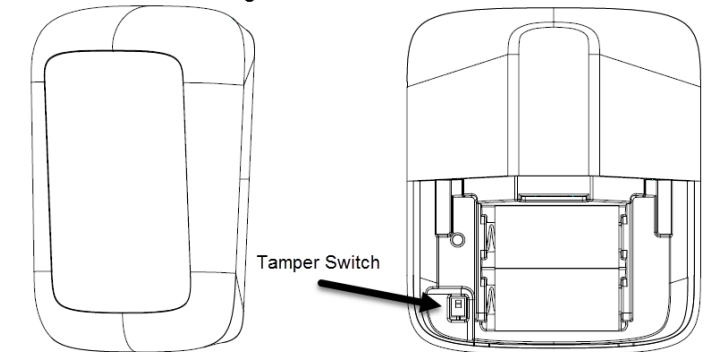

## 2. SPECIFICATIONS

Detector Type:	Two - Dual element low-noise pyroelectric sensor
Optical Data:	18 parabolic mirrors for long range 18 parabolic mirrors for close range
Max. Coverage:	15 x 15 m, (49.2 x 49.2 ft) / 90°
Pet Immunity:	Selectable: (1.No immunity 2. Up to 40 lb 3. Up to 85 lb)
<b>ELECTRICAL</b>	
Internal Batteries:	Two 3V Lithium batteries, type CR-123A. For UL installations, use Panasonic only
Nominal Battery Capacity:	1400 mAh per battery
Battery Life (with LED on):	Typically over 5 years <i>Note: Inability to connect with wireless network, or wireless link quality resulting in intermittent connection may significantly reduce the expected battery life.</i>
Battery Power Test:	Performed immediately upon battery insertion and during each transmission to the panel
<b>FUNCTIONAL</b>	
Alarm Period:	3 seconds
Visual Indications:	Red LED lights for about 3 seconds upon transmission of alarm & tamper messages and upon motion Detection in the walk test mode only (walk test mode available for approx. 15 minutes). Red LED flashes during the power-up stabilization period, or after restoring (pressing) the tamper switch (power-up stabilization period is approx. 1 minutes). LED does not light upon transmissions of supervision messages or alarm detection after termination of walk test mode.
Rearm Timer:	Rearms the detector 2 minutes after the last alarm. Timer disabled in the walk test mode.
<b>WIRELESS</b>	
Supported Network:	ZigBee H.A 1.2
Frequency:	2.405 – 2.480 Ghz as per IEEE 802.15.4
Tamper Alert:	Reported when a tamper event occurs and in any subsequent message, until the tamper switch is restored
<b>MOUNTING</b>	
Height:	1.8-2.4 m (6 - 8 ft). For pet rejection, the optimal height is 2.1 m (7 ft)
Installation Options:	Surface or corner
<b>ENVIRONMENTAL</b>	
Operating Temperatures	-10° C to 55° C (14° F to 131° F)
Storage Temperatures	-20° C to 65° C (-4° F to 149° F)
<b>COMPLIANCE WITH STANDARDS</b>	
USA	CFR 47 part 15, ANSI/UL 639
<b>PHYSICAL</b>	
Size (H x W x D)	83 x 61 x 42 mm (3.27 x 2.4 x 1.66")
Weight (with battery)	90 g (3.17 oz)
Color	White

### 3. INSTALLATION

#### 3.1 General Guidance

1. Do not install near heating and cooling sources.
2. Do not aim detector at windows due to risk of drafts.
3. Do not install outdoors.
4. Do not install where direct sunlight can strike the unit.
5. Do not install near high-voltage electrical lines.
6. Do not install behind any obstructions.
7. Do not mount on unstable surfaces.

Figure 2. General Guidelines

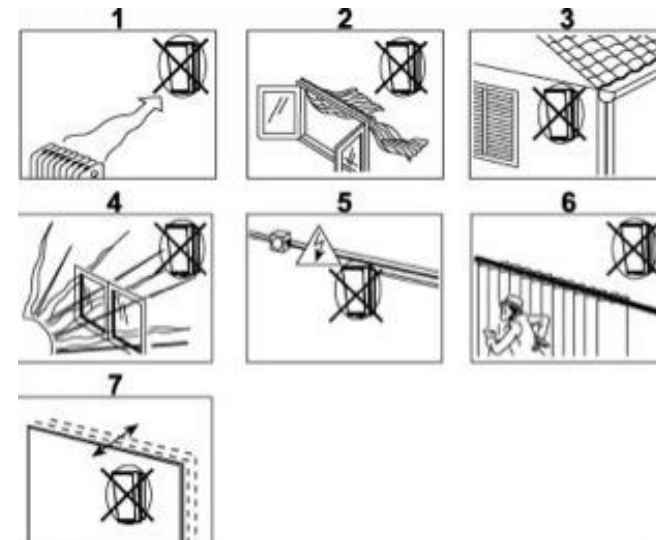

#### 3.2 Installation Procedure

1. Separate detector from bracket. Figure 3.
2. Remove the bracket.
3. Mount bracket to wall using the center screw holes (B) or corner screw holes (A1 & A2). Figure 4.
4. Install new batteries OR if batteries are installed, remove the activation strip.
5. Remount the detector by sliding it down onto the bracket until a click is heard. Figure 5.
6. The unit is ready for walk test.

Figure - 3



Figure - 5

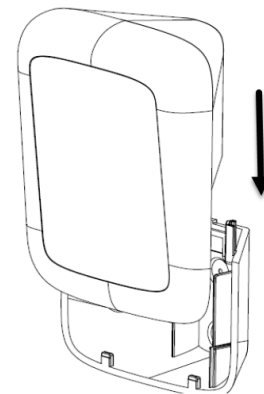
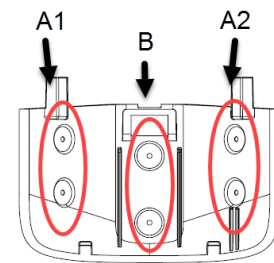

Figure - 4



#### 3.3 Replacing the Batteries

1. Press upward to separate the detector from the bracket.
2. Replace the batteries.
3. Put back the detector on the bracket.

**Note:** It is recommended to wait approximately 1 minute after battery removal before inserting the new battery.

**CAUTION!** Risk of explosion if battery is replaced by an incorrect type. Dispose of used battery according to the manufacturer's instructions.

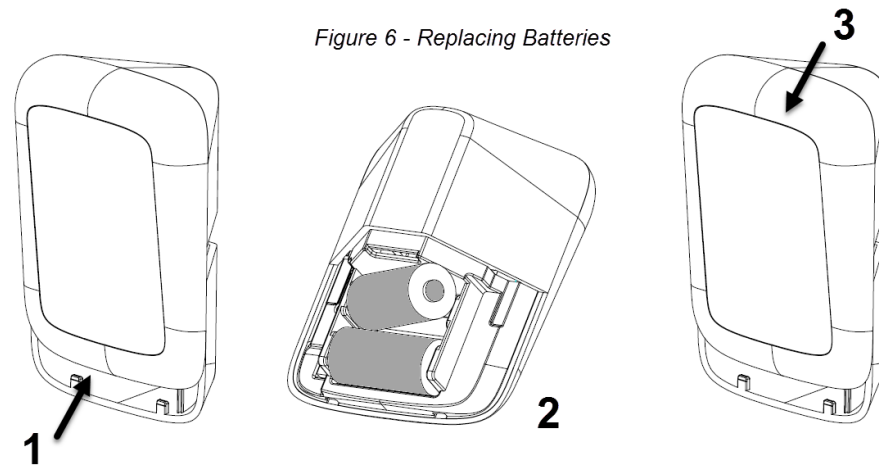

#### 3.4 Activating and Pairing the Detector

To pair the detector to the Touchscreen (control panel), you must set the detector to pairing mode.

1. First set the Touchscreen (panel) to pairing mode and then the detector.
2. To activate, pull the activation strip that protrudes from the back of the detector.
3. The green LED (see Figure 1) blinks 3 times every 5 seconds (repeated up to 20 times) to indicate that the detector is searching for the Touchscreen (control panel).  
*Note: If detector pairing is not successful during the searching process – by pressing the tamper switch – the searching process will restart.*
4. Complete the pairing procedure on the Touchscreen (control panel). See the pairing instructions in the Touchscreen (control panel) installation guide for details.  
*Note: Pairing should be performed before installation.*

After the installation a good link to the panel is displayed when the Received Signal Strength Indicator (RSSI) indicated on the panel is higher than -70dBm and the Link Quality Indicator (LQI) is stronger than 250.

If the RSSI and LQI values are lower, you must change the location of the detector.

#### 3.5 Rebooting the Detector

To reboot the detector, complete the following steps:

1. Remove the battery cover.
2. Press and release the tamper switch (see Figure – 1) for 1 to 2 seconds.
3. Close the battery cover.

#### 3.6 Return the Detector to default mode

**CAUTION!** The defaulting process removes the device from the network and enables re-pairing.

Prerequisite: Separate the detector from the bracket to remove both batteries.

See Figure 6 for details.

1. Press and hold down the detector's tamper switch.
2. Insert one of the two batteries into the detector while observing battery polarity.
3. Release the tamper switch within 4 seconds (the LED blinks 3 times every 5 seconds).
4. To re-pair the detector, follow the instructions in section 3.4.

*Note: It is recommended to wait about 1 minute after battery removal, before inserting the new battery.*

#### 3.7 Walk Testing

Walk across the far end of coverage pattern in both directions. The LED should light for 2-3 seconds each time your motion is detected.

**Important!** Instruct the user to walk test at least once a week to verify proper function of the detector.

**Note:** After battery insertion or closing the cover (which results in closing the tamper switch) the LED flashes for 2 minutes and the detector goes into walk-test mode for 15 minutes. In walk test mode the LED lights for every motion detected. After 15 minutes the detector automatically enters normal mode in which the LED will not blink after detection.

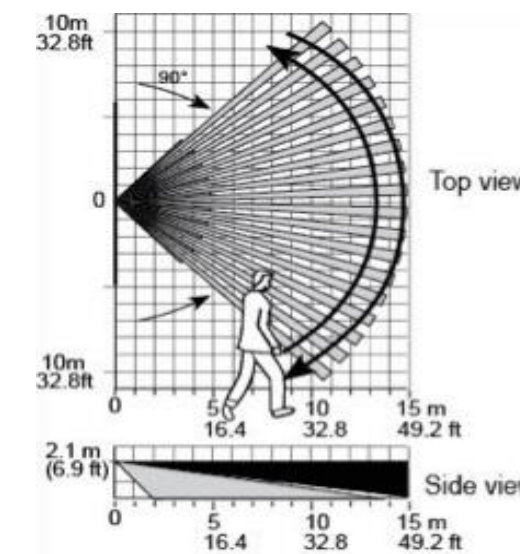

Figure 7 – Coverage Pattern Walk-Test