



INSTALLATION GUIDE

802.11a/b/g/n Outdoor Dual Band
Wireless Access Point

SMC2890W-AN, SMC2891W-AN



Outdoor Access Point Installation Guide

SMIC[®]

N e t w o r k s

No. 1, Creation Road III,

Hsinchu Science Park,

30077, Taiwan, R.O.C.

Tel: +886 3 5638888

Fax: +886 3 6686111

January 2013

Pub. # 14910000208A

E012013-CS-R01

Information furnished by SMC Networks, Inc. (SMC) is believed to be accurate and reliable. However, no responsibility is assumed by SMC for its use, nor for any infringements of patents or other rights of third parties which may result from its use. No license is granted by implication or otherwise under any patent or patent rights of SMC. SMC reserves the right to change specifications at any time without notice.

Copyright © 2013 by

SMC Networks, Inc.

No. 1 Creation Road III,
Hsinchu Science Park,
30077, Taiwan, R.O.C.

All rights reserved

Trademarks:

SMC is a registered trademark; and Barricade, EZ Switch, TigerStack, TigerSwitch, and TigerAccess are trademarks of SMC Networks, Inc. Other product and company names are trademarks or registered trademarks of their respective holders.

Warranty and Product Registration

To register SMC products and to review the detailed warranty statement, please refer to the Support Section of the SMC Website at <http://www.smc.com>.

How to Use This Guide

This guide includes detailed information on the Access Point (AP) hardware, including network ports, power, cabling requirements, as well as plug-in transceivers. This guide also provides general installation guidelines and recommended procedures. To deploy this AP effectively and ensure trouble-free operation, you should first read the relevant sections in this guide so that you are familiar with all its hardware components.

Who Should Read This Guide? This guide is for network administrators and support personnel that install, operate and maintain network equipment. The guide assumes a basic working knowledge of LANs (Local Area Networks) and can be read by those that are new to network equipment, or those with more experience.

How This Guide is Organized This organization of this guide is based on the AP's main hardware components. Each chapter includes information about a specific component with relevant specifications and installation procedures. An AP overview section is also provided.

For Users New to APs — If you are new to APs, it is recommended that you first read all chapters in this guide before installing the AP.

For Experienced Users — If you are already familiar with installing and operating network APs, Chapters 1 and 2 provide you with enough information to install the AP. Other chapters can be left for reference, when needed.

The guide includes these chapters:

- ◆ [Chapter 1 - Access Point Overview](#) — Includes an AP overview, key component identification, and key technical specifications.
- ◆ [Chapter 2 - Installation Overview](#) — Includes information on the package contents, system configuration, and an outline of AP installation tasks.
- ◆ [Chapter 3 - AP Chassis](#) — Includes AP installation for pole or wall, and external antenna connection.
- ◆ [Chapter 4 - Power and Grounding](#) — Includes information on PoE power for the unit, AP grounding, and powering on the AP.
- ◆ [Chapter 5 - Network Connections](#) — Includes information on network interfaces, installing optional transceivers, and cabling specifications.

- ◆ [Chapter 6 - AP Management](#) — Connecting to the AP for management and information on the system status LEDs.
- ◆ [Appendix A - Troubleshooting](#) — Information for troubleshooting AP installation and operation.

Related Documentation

This guide focuses on AP hardware and installation, it does not cover software configuration of the AP. For specific information on how to operate and use the management functions of the AP, see the following guide:

Management Guide

For all safety information and regulatory statements, see the following documents:

Quick Start Guide

Safety and Regulatory Information

Conventions

The following conventions are used throughout this guide to show information:



Note: Emphasizes important information or calls your attention to related features or instructions.



Caution: Alerts you to a potential hazard that could cause loss of data, or damage the system or equipment.



Warning: Alerts you to a potential hazard that could cause personal injury.

Revision History

This section summarizes the changes in each revision of this guide.

January 2013 Revision

This is the first revision of this guide.

Contents

Warranty and Product Registration	4
How to Use This Guide	5
Contents	7
Figures	9
Tables	10
1 Access Point Overview	11
Hardware Description	11
Key Hardware Components	12
Key Technical Specifications	15
2 Installation Overview	16
Package Contents	16
System Configuration	17
AP Installation Tasks	18
3 AP Chassis	23
General Installation Guidelines	23
Antenna Position	23
Ethernet Cabling	24
Radio Interference	24
Weather Conditions	24
How to Mount the Unit	25
How to Pole Mount	25
How to Connect External Antennas	27
How to Align Antennas	28
4 Power and Grounding	29
Power Injector Module	29

How to Ground the Unit	31
How to Install the Power Injector	32
5 Network Connections	35
Understanding the Network Status LEDs	36
How to Connect to Radio Interfaces	36
How to Connect to the RJ-45 Port	37
Copper Cabling Guidelines	37
10/100BASE-TX Pin Assignments	37
1000BASE-T Pin Assignments	38
Connection Procedure	39
Grounding the Ethernet Cable	41
6 AP Management	43
Understanding the System Status LEDs	44
How to Connect to the Console Port	45
A Troubleshooting	47
Diagnosing LED Indicators	47
System Self-Diagnostic Test Failure	47
Power Problems	47
Installation	48
Wireless Connection Problems	48
In-Band Access	48
Out-of-Band Access	49
Reset the Access Point	49
Index	50

Figures

Figure 1: SMC2891W-AN Outdoor Access Point	11
Figure 2: Bottom Panel View	12
Figure 3: Top Panel View (SMC2891W-AN)	13
Figure 4: Power Injector Module	14
Figure 5: System Configuration	17
Figure 6: Installing the AP on a Pole	18
Figure 7: Making a Connection to the RJ-45 Port	19
Figure 8: Connecting AC Power	20
Figure 9: System LEDs	20
Figure 10: Console Port	21
Figure 11: Attach Bracket to Pole	25
Figure 12: Attach Bracket to AP	26
Figure 13: Mount the AP on the Pole	26
Figure 14: Connect External Antennas	27
Figure 15: PoE Power Injector	29
Figure 16: Ground Wire Connection	31
Figure 17: Connecting the Power Injector	32
Figure 18: Network Status LEDs	36
Figure 19: Network Status LEDs	36
Figure 20: RJ-45 Connector	37
Figure 21: Waterproof RJ-45 Port Cover	40
Figure 22: Making a Connection to the RJ-45 Port	41
Figure 23: Outdoor-Rated Ethernet Cable Drain Wire	42
Figure 24: System Status LEDs	44
Figure 25: System Status LEDs	44
Figure 26: Console Port Connection	46

Tables

Table 1: Key Technical Specifications	15
Table 2: Power Injector Module Specifications	30
Table 3: Power Injector Module Status LED	30
Table 4: 10/100BASE-TX MDI and MDI-X Port Pinouts	38
Table 5: 1000BASE-T MDI and MDI-X Port Pinouts	39
Table 6: Console Cable Wiring	45
Table 7: Troubleshooting Chart	47

1

Access Point Overview

This chapter includes these sections:

- ◆ “Hardware Description” on page 11
- ◆ “Key Technical Specifications” on page 15

Hardware Description

The SMC2890W-AN/SMC2891W-AN outdoor access point (AP) is built with leading-edge technology to deliver reliable high-performance connectivity for your data network.

The SMC2890W-AN/SMC2891W-AN is a dual-band IEEE 802.a/b/g/n AP that is designed to deliver high-performance wireless services for clients or to provide bridge links between remote LANs. Housed in a weatherproof enclosure for mounting outdoors, the unit includes its own bracket for attaching to a pole, radio mast, or tower structure. The unit is powered through its Ethernet cable connection from a power injector module that is installed indoors.

In addition, the AP offers full network management capabilities through an easy-to-use web interface, a command-line interface, and support for Simple Network Management Protocol (SNMP) tools.

Figure 1: SMC2891W-AN Outdoor Access Point

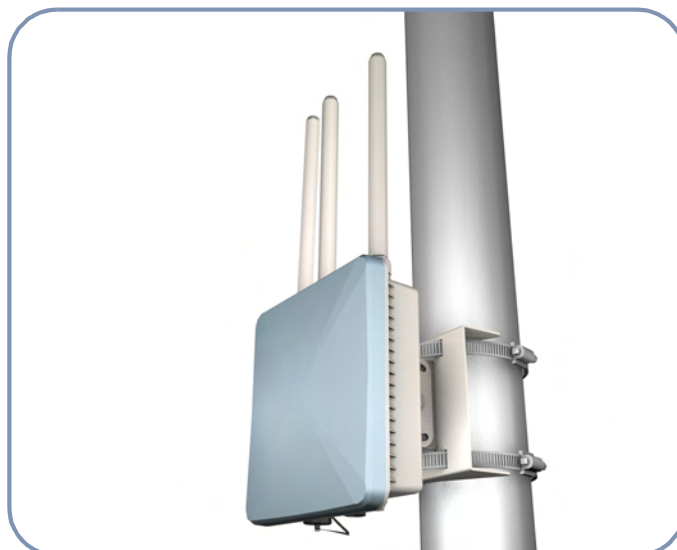

Key Hardware Components The SMC2890W-AN/SMC2891W-AN consists of several key hardware components. This manual describes each specific component, or related components, together with their installation requirements and procedures in each chapter. To understand each component in detail, refer to the relevant section.

Figure 2: Bottom Panel View

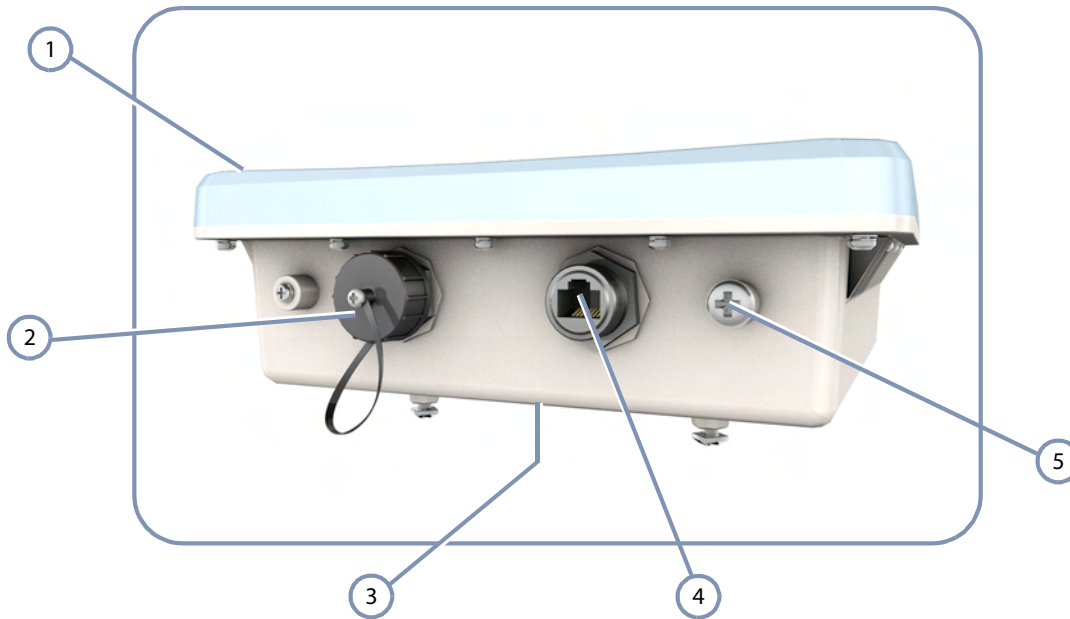

- | | |
|--|--|
| 1 Built-in 5 GHz Antenna (SMC2891W-AN only) | 4 RJ-45 PoE Port |
| 2 Console Port with Waterproof Cover | 5 Water-Tight Test Point (DO NOT REMOVE) |
| 3 Back Panel System LEDs (Not Visible in Figure) | |

Built-in 5 GHz Antenna

The SMC2891W-AN AP includes an integrated 5 GHz antenna. For more information, see [“How to Align Antennas” on page 28](#).

Console Port

The port labeled “Console” provides an out-of-band serial connection to a terminal or a PC running terminal emulation software. The port can be used for performing unit monitoring and configuration. For more information, see [“How to Connect to the Console Port” on page 45](#).

RJ-45 PoE Port

The RJ-45 port labeled “PoE” provides a 1000BASE-T data and Power-over-Ethernet (PoE) power connection to the unit. For more information, see [“How to Connect to the RJ-45 Port” on page 37](#).

System LEDs

For information on system status LED indicators, see [“Understanding the System Status LEDs”](#) on page 44.

Water-Tight Test Point



Caution: Do not remove or loosen this screw. Doing so could lead to damage of the unit.

Figure 3: Top Panel View (SMC2891W-AN)

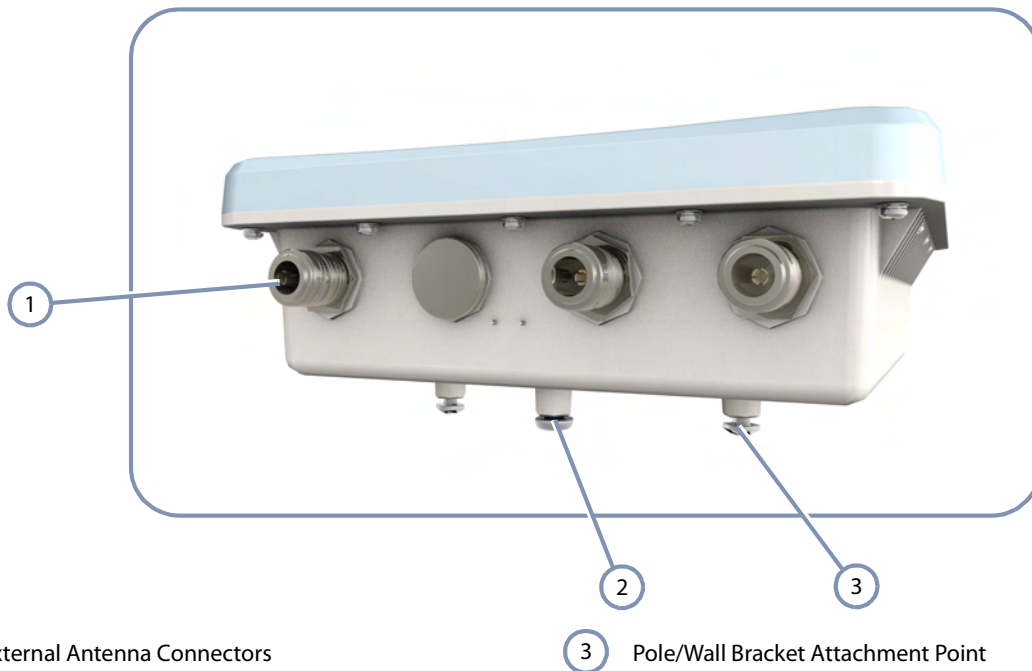

1 External Antenna Connectors

2 Ground Point

3 Pole/Wall Bracket Attachment Point

External Antenna Connectors

The SMC2890W-AN AP unit includes four external antenna connectors, two are for the 2.4 GHz radio and two for the 5 GHz radio. The SMC2891W-AN AP unit includes three external antenna connectors, two are for the 2.4 GHz radio and one for the 5 GHz radio (the unit also includes a built-in 5 GHz antenna). For more information, see [“How to Connect External Antennas”](#) on page 27.

Ground Point

There is a ground point for grounding the AP chassis to earth. For more information, see [“How to Ground the Unit”](#) on page 31.

Pole Mounting Bracket

The included Mounting Bracket Kit can be used to mount the unit on a 1.5 to 6 inch diameter pole, or to part of a radio mast or tower structure. For more information, see [“How to Mount the Unit”](#) on page 25.

Figure 4: Power Injector Module



Power Injector Module

The AP receives power through a PoE connection to its RJ-45 port. The PoE power is supplied from a power injector module that is installed indoors. For information, see [“Power Injector Module”](#) on page 29.

Key Technical Specifications

The following table contains key system specifications for the AP.

Table 1: Key Technical Specifications

Item	Specification
Ports	One 10/100/1000 Mbps RJ-45 port
Network Interface	RJ-45 Port: 1000BASE-T, PoE (PD) with waterproof cover
Console Port	RS-232, RJ-45 waterproof connector
2.4GHz Radio	IEEE 802.11b/g/n
5 GHz Radio	IEEE 802.11a/n
External Antennas	4 N-Type female connectors (50 Ohms), 2x2 MIMO for 2.4 and 5 GHz
Integrated Antenna (SMC2891W-AN only)	12 dBi @ 5 GHz, panel type, horizontal polarization
Radio Frequencies	2400 ~ 2483.5 MHz 2412 ~ 2472 MHz 5745 ~ 5825 MHz (China) 5180 ~ 5320 MHz (ETSI) 5500 ~ 5700 MHz (ETSI)
LEDs	Power/System, Ethernet, 2.4GHz, 5GHz
PoE Input Power	38~57 VDC
Power Consumption	25.5 W maximum for IEEE 802.3at 12.95 W maximum for IEEE 802.3af
Weight	1.7 kg (3.75 lbs), unit without bracket or external antennas
Size	W x D x H: 195 x 190 x 74 mm (7.68 x 7.48 x 2.91 inches)
Temperature	Operating: -10 °C to 60 °C (-14 °F to 140 °F) Storage: -20 °C to 70 °C (-4 °F to 158 °F)
Humidity	Operating: 10% to 95% (non-condensing)
Wind Velocity	Operational: 100 MPH (Miles per hour) / 44 mps Survival: 150 MPH / 66 mps

2

Installation Overview

This chapter includes these sections:

- ◆ “Package Contents” on page 16
- ◆ “System Configuration” on page 17
- ◆ “AP Installation Tasks” on page 18

Package Contents

After unpacking the AP, check the contents to be sure you have received all the components.

- ◆ SMC2890W-AN or SMC2891W-AN Outdoor Access Point
- ◆ Bracket Mounting Kit for pole mounting
- ◆ PoE Power Injector with power cord—either US, Continental Europe or UK
- ◆ Waterproof RJ-45 port cover
- ◆ Console cable (RJ-45 to DB-9)
- ◆ Quick Start Guide
- ◆ Regulatory and Safety Information
- ◆ Documentation CD — includes *Installation Guide* and *Management Guide*

Note that the following items are available options for the AP:

- ◆ (Optional) Two external 2.4 GHz antennas
- ◆ (Optional) One external 5 GHz antenna
- ◆ (Optional) One mounting kit for 5 GHz external antenna
- ◆ (Optional) 1.5 m low-loss 200 RF cable for 5 GHz external antenna

System Configuration

At each location where a unit is installed it must be connected to the local network, either by using the power injector module, or by a direct connection to an IEEE 802.3at-compliant LAN switch.

The following figure illustrates the system component connections.

Figure 5: System Configuration

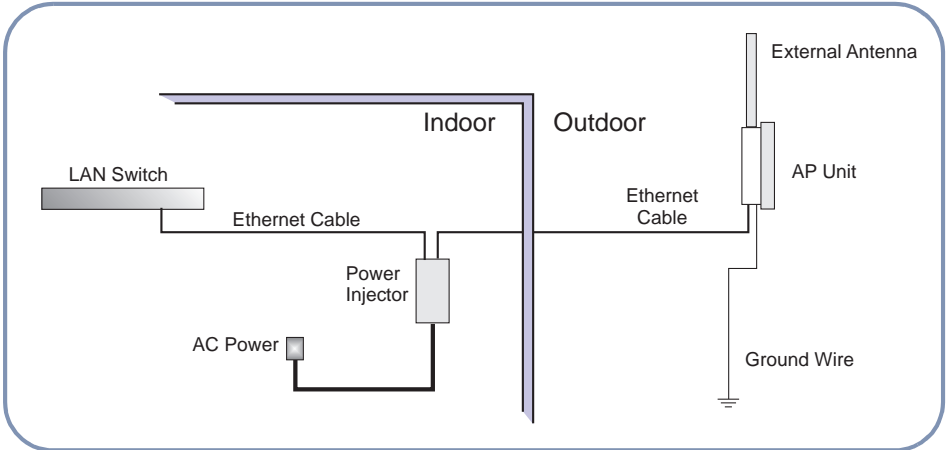

AP Installation Tasks

Follow these tasks to install the AP in your network. For full details on each task, go to the relevant chapter or section by clicking on the link.

Task 1 **Unpack package and check contents**

Unpack your AP and check the package contents to be sure you have received all the items.

Before installing your AP, be sure to review all the safety statements and guidelines in the *Regulatory and Safety Information* document.

Task 2 **Mount the AP**

After planning your installation, mount the unit on a pole, mast, or tower using the mounting bracket. Also install the external antennas required for your wireless service.

➔ [Go to the chapter "AP Chassis"](#)

Figure 6: Installing the AP on a Pole

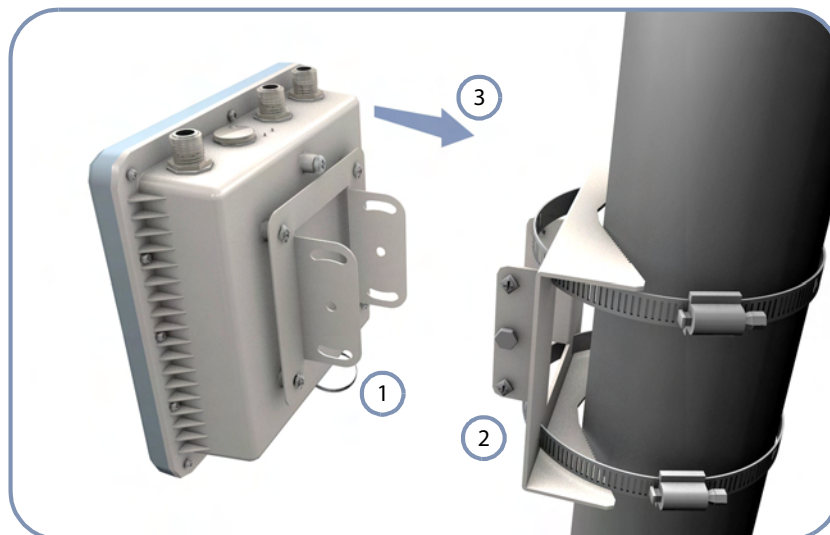

- 1 Attach one part of the bracket to the AP.
- 2 Attach the other parts of the bracket to the pole.
- 3 Link the two bracket parts together to secure the AP to the pole.

Task 3 Connect Cables

Connect an Ethernet cable and a grounding wire to the unit.

Use outdoor-rated straight-through Ethernet cable to connect to the RJ-45 port for your network connection.

➔ Go to the chapter [“Network Connections”](#)

For details on connecting a ground wire:

➔ Go to the section [“How to Ground the Unit”](#)

Figure 7: Making a Connection to the RJ-45 Port



① Connect outdoor-rated Category 5e or better cable to the RJ-45 port.

② Be sure to use the waterproof cover on the port.

Task 4 Install the PoE Power Injector and Power On

Install the PoE power injector indoors. Connect the power injector to the Ethernet cable, a local LAN switch, and an AC power source.

Note that the AP can also be powered by connecting directly to a IEEE 802.3at PoE switch.

➔ Go to the chapter [“Power and Grounding”](#)

Figure 8: Connecting AC Power

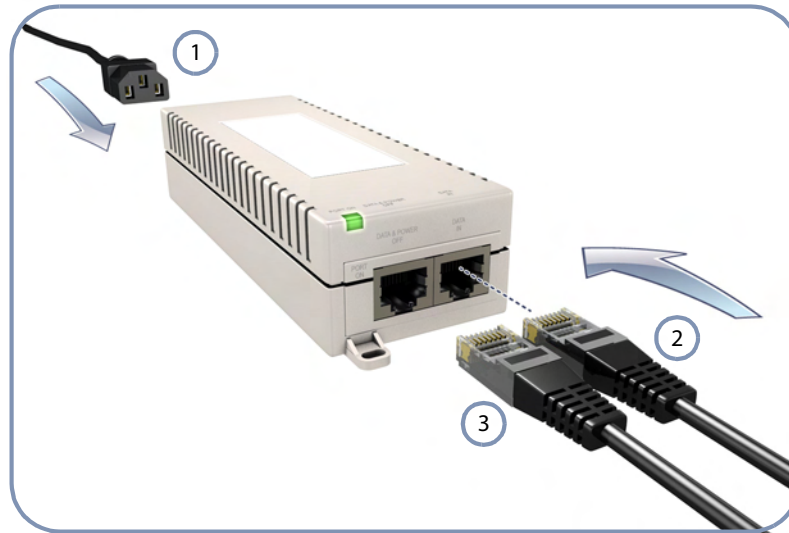

- 1 Connect the AC power cord to a nearby AC power source.
- 2 Connect Ethernet cable from the “DATA IN” port to a LAN switch.
- 3 Connect straight-through Ethernet cable from the AP to the “DATA & POWER OUT” port.

Task 5 Verify AP Operation

Verify basic AP operation by checking the system LEDs.

When operating normally the Pwr/Sys LED should be on green, the Ethernet LED on/blinking orange, and the wireless interface LEDs on/blinking orange.

➔ Go to the section [“Understanding the System Status LEDs”](#)

Figure 9: System LEDs



- 1 System Status LEDs.

Task 6 Make Initial Configuration Changes

At this point you may need to make a few basic configuration changes to the AP so that it is compatible with your network. It is suggested to connect to the AP console port to perform this task.

➔ Go to ["How to Connect to the Console Port"](#)

Figure 10: Console Port



① Console Port.

For information on AP configuration:

➔ Refer to the *Management Guide*.

3

AP Chassis

The AP includes its own bracket kit for mounting the unit to a 1.5 to 6 inch diameter pole or part of a radio mast or tower structure.

Before continuing with AP installation, first review the general guidelines and requirements in this chapter.

This chapter includes these sections:

- ◆ [“General Installation Guidelines” on page 23](#)
- ◆ [“How to Mount the Unit” on page 25](#)
- ◆ [“How to Connect External Antennas” on page 27](#)
- ◆ [“How to Align Antennas” on page 28](#)

General Installation Guidelines

Be sure to follow the guidelines below when choosing a location.



Caution: The planning and installation of the AP requires professional personnel that are trained in the installation of radio transmitting equipment. The user is responsible for compliance with local regulations concerning items such as antenna power, use of lightning arrestors, grounding, and radio mast or tower construction. Therefore, it is recommended to consult a professional contractor knowledgeable in local radio regulations prior to equipment installation.

Antenna Position When planning a location for the AP, consider these guidelines:

- ◆ When installing for an access point service, be sure to place the unit and external antennas in a location that can cover the intended service area.
- ◆ Be sure there are no other radio antennas within 2 m (6 ft) of the AP.
- ◆ Place the AP away from power and telephone lines.
- ◆ Avoid placing the AP too close to any metallic surfaces, such as roof-installed air-conditioning equipment, tinted windows, wire fences, or water pipes.

Ethernet Cabling From the intended AP location, plan a cable route from the unit outdoors to the power injector module indoors. Consider these guidelines:

- ◆ The total Ethernet cable length should never be longer than 100 m (328 ft).
- ◆ Determine a building entry point for the cable.
- ◆ Determine if conduits, bracing, or other structures are required for safety or protection of the cable.
- ◆ For lightning protection at the power injector end of the cable, consider using a lightning arrester immediately before the cable enters the building.

Radio Interference The avoidance of radio interference is an important part of wireless network planning. Interference is caused by other radio transmissions using the same or an adjacent channel frequency. You should first scan your proposed site using a spectrum analyzer to determine if there are any strong radio signals using the 802.11a/b/g/n channel frequencies. Always use a channel frequency that is furthest away from another signal.

Weather Conditions When planning outdoor networks, you must take into account any extreme weather conditions that are known to affect your location. Consider these factors:

- ◆ **Temperature** — The AP is tested for normal operation in temperatures from -10° C to 60° C. Operating in temperatures outside of this range may cause the unit to fail.
- ◆ **Wind Velocity** — The AP can operate in winds up to 44 m/s and survive higher wind speeds up to 66 m/s. You must consider the known maximum wind velocity and direction at the site and be sure that any supporting structure, such as a pole, mast, or tower, is built to withstand this force.
- ◆ **Lightning** — The AP includes its own built-in lightning protection. However, you should make sure that the unit, any supporting structure, and cables are all properly grounded. Additional protection using lightning rods, lightning arrestors, or surge suppressors may also be employed.
- ◆ **Rain** — The AP is weatherproofed against rain. Also, prolonged heavy rain has no significant effect on the radio signal. However, it is recommended to apply weatherproof sealing tape around all connectors for extra protection.
- ◆ **Snow and Ice** — Falling snow, like rain, has no significant effect on the radio signal. However, a build up of snow or ice on antennas may cause links to fail. In this case, the snow or ice has to be cleared from the antennas to restore operation of the unit.

How to Mount the Unit

The AP can be mounted in the following ways using the included mounting bracket:

- ◆ To a 1.5 to 6 inch diameter pole

The AP's mounting bracket has two main parts. One part that can be secured to a pole using two steel-band clamps, and another part that attaches directly to the AP. The two parts link together and allow the tilt angle of the unit to be adjusted for antenna alignment.

How to Pole Mount Perform the following steps to mount the unit to a 1.5 to 6 inch diameter pole or tube using the mounting bracket:

1. Using the two included steel-band clamps, thread them through the slats provided in the pole-mount part of the bracket.
2. Place the pole-mount part of the bracket against the pole and tighten the steel-band clamps until it is secure.

Figure 11: Attach Bracket to Pole

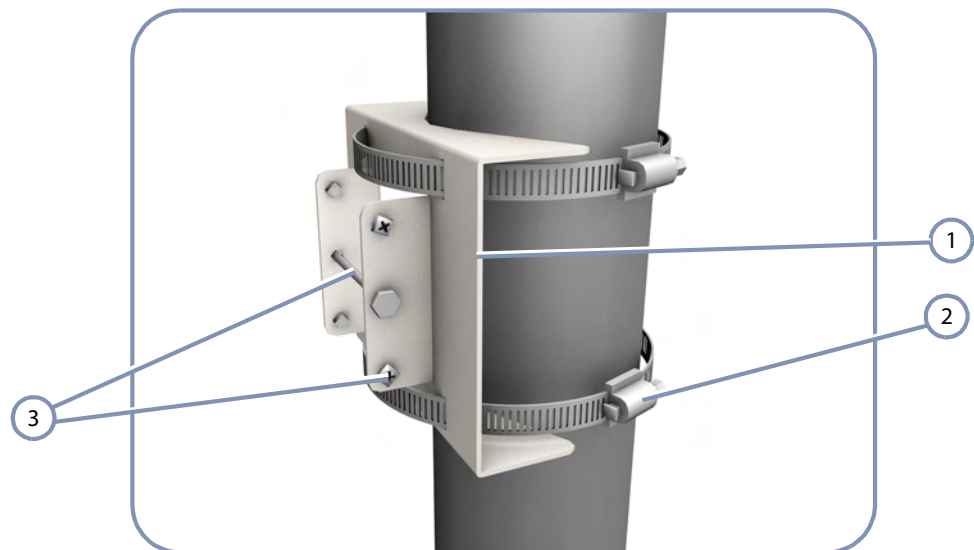

- 1 Pole Mount Bracket Part
- 2 Steel-Band Clamps
- 3 Securing Screws, Nut and Bolt

3. Attach the square mounting plate to the AP with the supplied screws.

Figure 12: Attach Bracket to AP



- ① Bracket Mount Points
- ② Square Mounting Bracket Part
- ③ Supplied Bracket Mount Screws

- 4. Attach the AP with its mounting plate to the bracket already fixed to the pole.
- 5. Use the included long bolt to secure the AP to the pole bracket. Note that the AP tilt angle may need to be adjusted for antenna alignment.

Figure 13: Mount the AP on the Pole

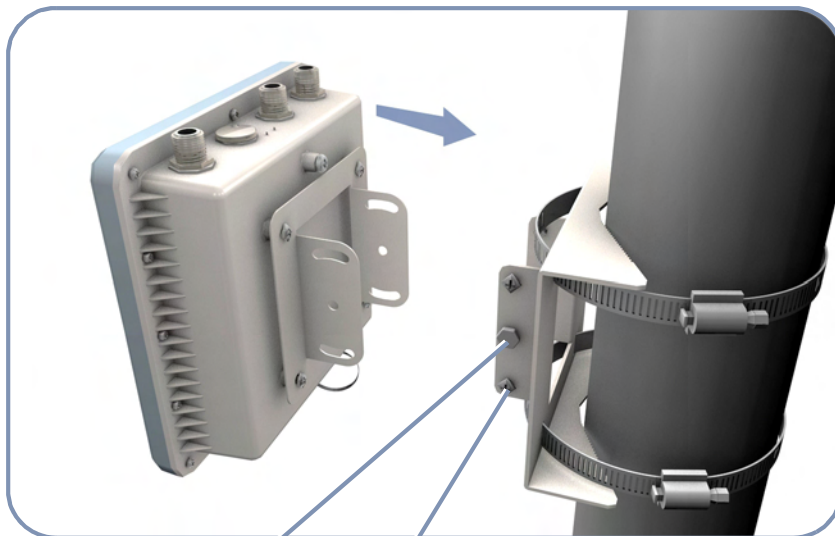

- ① Long Steel Bolt
- ② Tilt Angle Securing Screws (Four)

- Secure the AP at the required tilt angle using the two screws provided in the mounting kit.

How to Connect External Antennas

When deploying an AP, you need to mount external antennas and connect them to the unit. Two antennas are required for 2.4 GHz operation and two can be used for 5 GHz operation. These antennas are not included in the AP package.

The SMC2891W-AN unit includes an integrated high-gain antenna for 5 GHz operation. External antennas are not required for 5 GHz operation only for 2.4 GHz operation.

Some omnidirectional external antennas attach directly to the N-type connectors on the unit. Other antennas may include their own mounting brackets and connect to the unit using RF coaxial cables.

Perform these steps:

- For external antennas with mounting brackets, mount the antennas to the same supporting structure as the AP, within 3 m (10 ft) distance, using the brackets supplied in the antenna package.
- Connect the antennas either directly to the AP's N-type connectors, or use RF coaxial cable provided in the antenna package.

Figure 14: Connect External Antennas

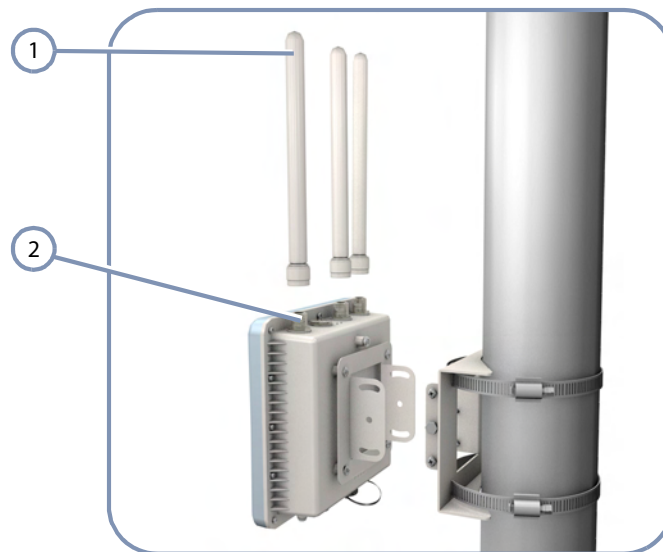

1 Direct-Attach Omnidirectional External Antennas

2 N-Type External Antenna Connectors

3. Apply weatherproofing tape to the antenna connectors to help prevent water entering the connectors.



Note: Be sure to take account of the antenna polarization direction; all antennas in a link must be mounted with the same polarization.

How to Align Antennas

When using the SMC2891W-AN unit with its 5 GHz integrated high-gain antenna, you will need to accurately align the antenna with another unit in the network to ensure optimum performance. Proper antenna alignment is particularly important for long-range point-to-point links.

- ◆ **Point-to-Point Configurations** — In a point-to-point configuration the alignment process requires two people at each end of the link. The use of cell phones or two-way radio communication may help with coordination. To start, you can just point the antennas at each other, using binoculars or a compass to set the general direction. Then you can adjust the horizontal and vertical position to find the position where the signal is strongest and secure the unit in that position.
- ◆ **Point-to-Multipoint Configurations** — In a point-to-multipoint configuration all SMC2891W-AN units must be aligned with a central SMC2890W-AN unit that may be using external omnidirectional or sector antennas. The alignment process is the same as in point-to-point links, but only the SMC2891W-AN units require the adjustment for proper alignment.

To start, you can just point the SMC2891W-AN antenna at the central SMC2890W-AN unit, using binoculars or a compass to set the general direction. Then you can adjust the horizontal and vertical position to find the position where the signal is strongest and secure the unit in that position.



Note: The receive signal strength of the radio signal on the local and remote unit can be viewed using the CLI or web management interfaces. Refer the *Management Guide* for further information.

4

Power and Grounding

This chapter focuses on how to power-on the AP. The AP can be powered using the included PoE Power Injector or by a direct connection to a PoE LAN switch. Connecting the AP to ground is also covered.

This chapter includes these sections:

- ◆ “Power Injector Module” on page 29
- ◆ “How to Ground the Unit” on page 31
- ◆ “How to Install the Power Injector” on page 32

Power Injector Module

The AP receives power through its network cable connection using power-over-Ethernet technology. A power injector module is included in the AP package and provides two RJ-45 Ethernet ports, one for connecting to the AP (DATA & POWER OUT), and the other for connecting to a local LAN switch (DATA IN).

The DATA IN port uses an MDI (that is, internal straight-through) pin configuration. You can therefore use straight-through twisted-pair cable to connect this port to most network interconnection devices such as a switch or router that provide MDI-X ports. However, when connecting the access point to a workstation or other device that does not have MDI-X ports, you must use crossover twisted-pair cable.

Figure 15: PoE Power Injector

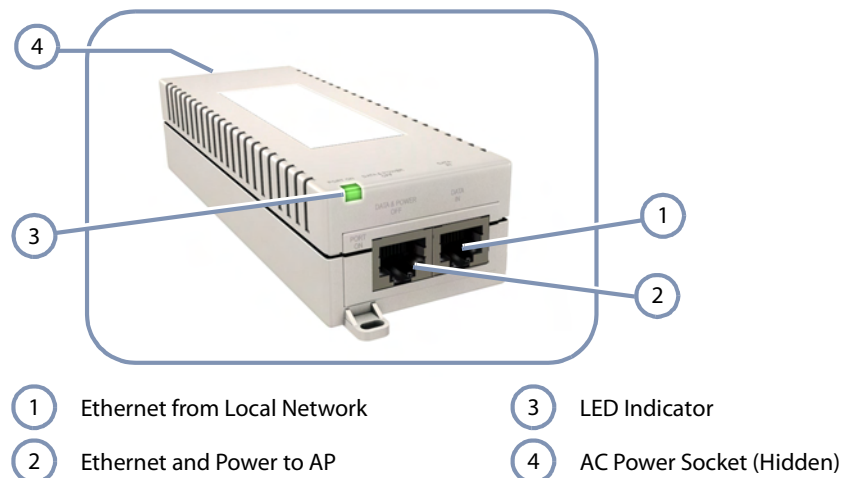

Table 2: Power Injector Module Specifications

Item	Description
AC Input	100~240 VAC, 50/60 Hz, 0.5 A
DC Output	48 VDC, 0.35 A
Output Power	16.8 W maximum
DATA IN Port	10/100/1000BASE-T, RJ-45 socket
DATA & POWER OUT Port	10/100/1000BASE-T, RJ-45 socket 50 VDC on wire pairs 4, 5 (+) and 7, 8 (-)
Temperature	Operating: 0 - 40 °C (32 - 104 °F) Storage: -20 - 70 °C (-4 - 158 °F)
Humidity	Operating: 10 - 90% non-condensing Storage: 10 - 90% non-condensing
Size	W x L x H: 50 x 140 x 35 mm (4.2 x 9.0 x 1.6 inches)

The AP does not have a power switch. It is powered on when its Ethernet port is connected to the power injector module, and the power injector module is connected to an AC power source.

The power injector includes one LED indicator that turns on when AC power is applied.

Table 3: Power Injector Module Status LED

LED Status	Indication
On Yellow	Module is receiving power.
On Green	The module is connected to the AP and supplying power.
Blinking Green	Module has detected an overload state or short-circuit condition.

The power injector module automatically adjusts to any AC voltage between 100-240 volts at 50 or 60 Hz. No voltage range settings are required.



Caution: The power injector module is designed for indoor use only. Never mount the power injector outside with the AP unit.

How to Ground the Unit

When connecting a ground wire to the AP, use the grounding screw on the unit. Be sure to use #14 AWG or larger copper core ground wire.



Caution: Be sure that grounding is available and that it meets local and national electrical codes. Grounding the AP must be performed by a professional installer.

The ground wire can be connected to a point on the bracket, pole, metal grounding plate, or directly to an earth termination. Make sure that there is a good electrical connection between the ground wire and the grounding point (no paint or isolating surface treatment).

To connect a grounding wire to the AP, follow these steps:

1. Crimp a ring lug onto the end of the ground wire before connecting it to the unit.
2. Place the ground wire lug on one of the grounding points and firmly tighten the screw.

Figure 16: Ground Wire Connection

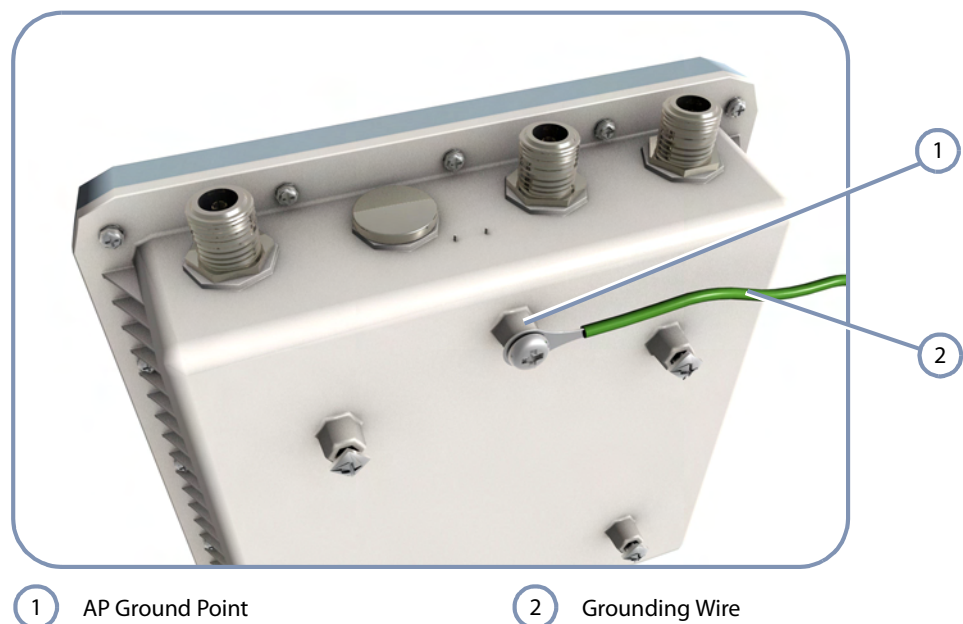

3. Connect the other end of the grounding wire to a good ground (earth) connection.



Note: Use cable strips to secure all cables to the pole.

How to Install the Power Injector

The power injector can be installed indoors on any horizontal surface, such as a desktop or shelf, or on a wall.



Caution: Do not install the power injector outdoors. The unit is for indoor installation only.

Caution: Install lightning protection at the power injector end of the Ethernet cable, use a lightning arrestor immediately before the cable enters the building.

Figure 17: Connecting the Power Injector

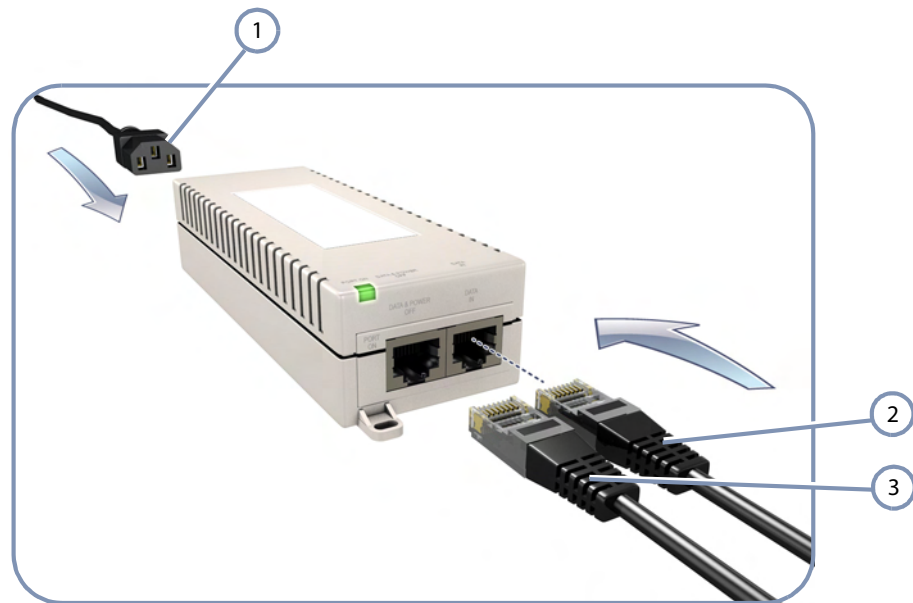

1 AC Power Cord

2 DATA IN Port

3 DATA & POWER OUT Port

1. Connect outdoor-rated Ethernet cable from the AP to the RJ-45 port labeled "DATA & POWER OUT" on the power injector.
2. Connect a straight-through unshielded twisted-pair (UTP) cable from a local LAN switch to the RJ-45 port labeled "DATA IN" on the power injector. Use Category 5e or better UTP cable for 10/100/1000BASE-T connections.

3. Insert the power cable plug into the standard AC socket on the power injector and the other end into a grounded, 3-pin socket, AC power source.



Note: For International use, you may need to change the AC line cord. You must use a line cord set that has been approved for the socket type in your country.

4. Check the LED on top of the power injector to be sure that power is being supplied to the power injector.

5

Network Connections

This chapter focuses on making connections to the AP's network interfaces and details on network cable specifications.

The AP features one 1000BASE-T RJ-45 port as well as wireless interfaces. The sections that follow describe the network interfaces.

This chapter includes these sections:

- ◆ ["Understanding the Network Status LEDs" on page 36](#)
- ◆ ["How to Connect to Radio Interfaces" on page 36](#)
- ◆ ["How to Connect to the RJ-45 Port" on page 37](#)

Understanding the Network Status LEDs

The AP includes LED indicators to indicate network link status and activity. The LEDs are shown below and are described in the following table.

Figure 18: Network Status LEDs

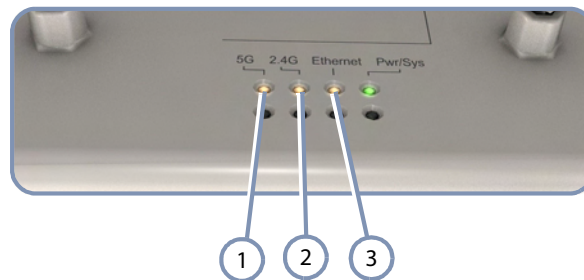

- 1 5 GHz Link/Activity LED
- 2 2.4 GHz Link/Activity LED
- 3 LAN Link/Activity LED

Figure 19: Network Status LEDs

LED	Condition	Status
Ethernet	On Orange	Port has a valid link.
	Blinking Orange	Indicates activity on the port.
	Off	The link is down.
2.4G	On Orange	The 802.11b/g/n 2.4 GHz radio is enabled.
	Blinking Orange	Indicates network activity.
	Off	The 2.4 GHz radio is disabled.
5G	On Orange	The 802.11a/n 5 GHz radio is enabled.
	Blinking Orange	Indicates network activity.
	Off	The 5 GHz radio is disabled.

How to Connect to Radio Interfaces

The 802.11a standard operates in the 5 GHz Unlicensed National Information Infrastructure (UNII) band, and the 802.11b/g standard in the 2.4 GHz band. The 802.11n standard operates in both the 2.4 GHz and 5 GHz bands.

Once the AP is installed and powered on, wireless clients can connect to the 802.11b/g/n radio interface using the 2.4 GHz band, or to the 802.11a/n radio using the 5 GHz band. The radio and authentication settings for wireless clients can be configured through management interfaces. For more information, refer to the *Management Guide*.

How to Connect to the RJ-45 Port

The connection between the AP's RJ-45 port and the PoE power injector requires outdoor-rated Category 5E or better Ethernet cable with RJ-45 plugs on each end. The length of the Ethernet cable should be less than 100 meters (328 ft).

Copper Cabling Guidelines Before connecting the Ethernet copper cable, first plan a cable route from the AP outdoors to the PoE power injector indoors. Consider these guidelines:

- ◆ Make sure the cable distance does not exceed 100 meters (328 ft).
- ◆ Determine a building entry point for the cable.
- ◆ Determine if conduits, bracing, or other structures are required for safety or protection of the cable.
- ◆ Be sure to ground the outdoor-rated Ethernet cable immediately before it enters the building. See ["Grounding the Ethernet Cable" on page 41](#).
- ◆ For additional lightning protection, it is recommended to use a lightning arrestor immediately before the Ethernet cable enters the building.

10/100BASE-TX Pin Assignments Most 100BASE-TX RJ-45 ports support automatic MDI/MDI-X operation, so you can use straight-through or crossover cables for all network connections to PCs, switches, or hubs. In straight-through cable, pins 1, 2, 3, and 6, at one end of the cable, are connected straight through to pins 1, 2, 3, and 6 at the other end of the cable.

Figure 20: RJ-45 Connector

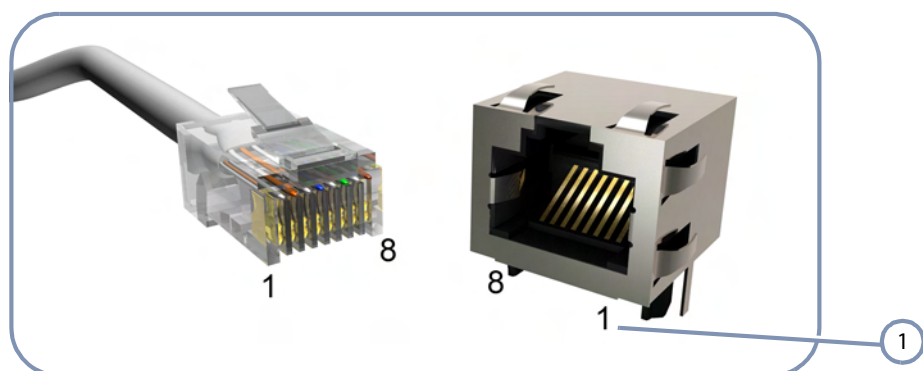

1 RJ-45 Pin Numbers

Table 4: 10/100BASE-TX MDI and MDI-X Port Pinouts

Pin	MDI Signal Name ^a	MDI-X Signal Name
1	Transmit Data plus (TD+) -52V power (Negative V_{port})	Receive Data plus (RD+) GND (Positive V_{port})
2	Transmit Data minus (TD-) -52V power (Negative V_{port})	Receive Data minus (RD-) GND (Positive V_{port})
3	Receive Data plus (RD+) GND (Positive V_{port})	Transmit Data plus (TD+) -52V power (Negative V_{port})
4	-52V power (Negative V_{port})	GND (Positive V_{port})
5	-52V power (Negative V_{port})	GND (Positive V_{port})
6	Receive Data minus (RD-) GND (Positive V_{port})	Transmit Data minus (TD-) -52V power (Negative V_{port})
7	GND (Positive V_{port})	-52V power (Negative V_{port})
8	GND (Positive V_{port})	-52V power (Negative V_{port})

a. The "+" and "-" signs represent the polarity of the wires that make up each wire pair.

1000BASE-T Pin Assignments All 1000BASE-T ports support automatic MDI/MDI-X operation, so you can use straight-through cables for all network connections to PCs or servers, switches or hubs.

The table below shows the 1000BASE-T MDI and MDI-X port pinouts. These ports require that all four pairs of wires be connected. Note that for 1000BASE-T operation, all four pairs of wires are used for both transmit and receive.

Table 5: 1000BASE-T MDI and MDI-X Port Pinouts

Pin	MDI Signal Name	MDI-X Signal Name
1	Bi-directional Pair A Plus (BI_DA+) -52V power (Negative V_{port})	Bi-directional Pair B Plus (BI_DB+) GND (Positive V_{port})
2	Bi-directional Pair A Minus (BI_DA-) -52V power (Negative V_{port})	Bi-directional Pair B Minus (BI_DB-) GND (Positive V_{port})
3	Bi-directional Pair B Plus (BI_DB+) GND (Positive V_{port})	Bi-directional Pair A Plus (BI_DA+) -52V power (Negative V_{port})
4	Bi-directional Pair C Plus (BI_DC+) -52V power (Negative V_{port})	Bi-directional Pair D Plus (BI_DD+) GND (Positive V_{port})
5	Bi-directional Pair C Minus (BI_DC-) -52V power (Negative V_{port})	Bi-directional Pair D Minus (BI_DD-) GND (Positive V_{port})
6	Bi-directional Pair B Minus (BI_DB-) GND (Positive V_{port})	Bi-directional Pair A Minus (BI_DA-) -52V power (Negative V_{port})
7	Bi-directional Pair D Plus (BI_DD+) GND (Positive V_{port})	Bi-directional Pair C Plus (BI_DC+) -52V power (Negative V_{port})
8	Bi-directional Pair D Minus (BI_DD-) GND (Positive V_{port})	Bi-directional Pair C Minus (BI_DC-) -52V power (Negative V_{port})

1000BASE-T Cable Requirements

All Category 5 UTP cables that are used for 100BASE-TX connections should also work for 1000BASE-T, providing that all four wire pairs are connected. However, it is recommended that for all critical connections, or any new cable installations, Category 5e (enhanced Category 5) or Category 6 cable should be used. The Category 5e and 6 specifications include test parameters that are only recommendations for Category 5. Therefore, the first step in preparing existing Category 5 cabling for running 1000BASE-T is a simple test of the cable installation to be sure that it complies with the IEEE 802.3-2008 standards.

Connection Procedure Follow these steps to connect Ethernet copper cable to the AP's RJ-45 twisted-pair copper port:



Note: Connecting the Ethernet cable to the AP powers on the unit.

1. Disassemble the waterproof port cover into its five parts; the outer screw-on cover, the screw-on cable clamp, the inner plastic RJ-45 plug cover, the inner rubber cable seal, and the rubber port seal.

Figure 21: Waterproof RJ-45 Port Cover

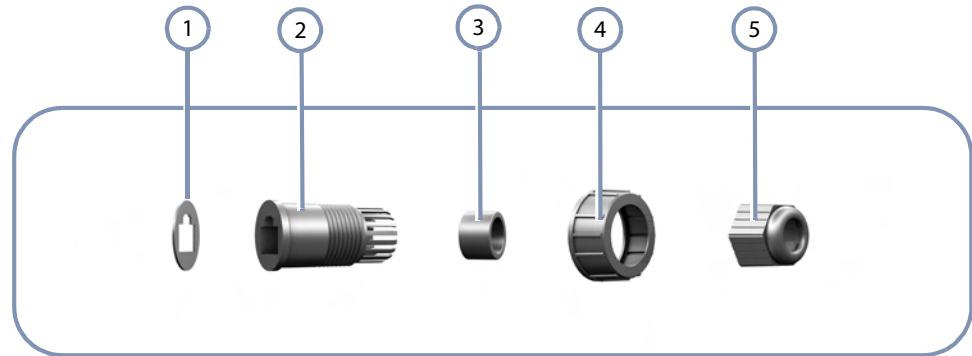

- | | |
|----------------------------------|------------------------|
| ① Rubber RJ-45 Port Seal | ④ Outer Screw-on Cover |
| ② Inner Plastic RJ-45 Plug Cover | ⑤ Screw-on Cable Clamp |
| ③ Inner Rubber Cable Seal | |

2. Peel-off the adhesive backing on the rubber RJ-45 port seal and stick it on the end of the plastic RJ-45 plug cover.
3. Cut the Ethernet cable to the required length, and then feed the cable end through the RJ-45 port waterproof cover parts in this order:
 - Screw-on cable clamp
 - Outer screw-on cover
 - Inner rubber cable seal
 - Inner plastic RJ-45 plug cover (with rubber seal attached)
4. Crimp a new RJ-45 connector (not supplied) on the end of the Ethernet cable.
5. Push the inner rubber cable seal into the clamp end of the plastic RJ-45 plug cover.
6. Connect the RJ-45 plug to the AP's RJ-45 port.
7. Push the inner plastic RJ-45 plug cover over the RJ-45 plug, and then secure it to the AP using the outer screw-on cover. Tighten the outer screw-on cover to ensure protection against moisture.
8. Screw the inner rubber cable seal onto the inner plastic RJ-45 plug cover. Tighten the seal to ensure protection against moisture.

Figure 22: Making a Connection to the RJ-45 Port

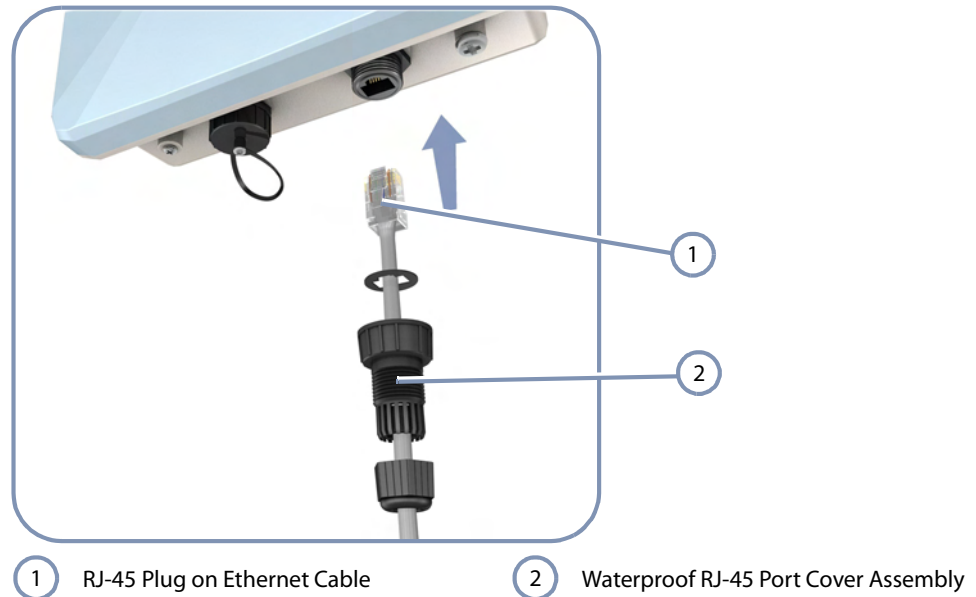

9. Seal the PoE port connector using tar seal or weatherproof tape for extra protection against rain and moisture.
10. Route the Ethernet cable from the AP to the power injector (or PoE LAN switch) following your cable plan and connect it to the "DATA & POWER OUT" port. The Power LED on the AP should turn on to indicate a valid link.

Grounding the Ethernet Cable

To comply with safety regulations, the shield of the outdoor-rated Ethernet cable must be connected to protective ground (earth). The grounding point can be either inside the building, or immediately at the entry point to the building, depending on where a protective ground is available.



Caution: Grounding the outdoor-rated Ethernet cable must be performed by a professional installer in conformance with local safety regulations.

This document proposes one method for grounding the outdoor-rated Ethernet cable through its drain wire. The actual connection method employed is left to the professional installer.

To ground the outdoor-rated Ethernet cable, follow these steps:

1. Strip back about a one inch (2.4 cm) section of the Ethernet cable jacket to expose the drain wire.

Figure 23: Outdoor-Rated Ethernet Cable Drain Wire

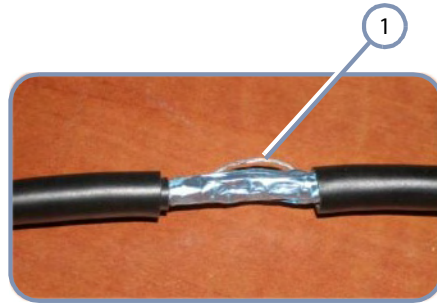

1 Drain Wire

2. Attach a grounding cable to the drain wire and then connect it to protective earth.
3. Use weatherproof tape to cover and seal the attachment area on the Ethernet cable.

6

AP Management

The AP includes a management agent that allows you to configure or monitor the AP using its embedded management software. To manage the AP, you can make a direct connection to the console port (out-of-band), or you can manage it through a network connection (in-band) using Telnet, Secure Shell (SSH), a web browser, or SNMP-based network management software.

For a detailed description of the AP's software features, refer to the *Management Guide*.

This chapter includes these sections:

- ◆ ["Understanding the System Status LEDs" on page 44](#)
- ◆ ["How to Connect to the Console Port" on page 45](#)

Understanding the System Status LEDs

The AP includes LED indicators that indicate system and port status. The LEDs are shown below and are described in the following table.

Figure 24: System Status LEDs

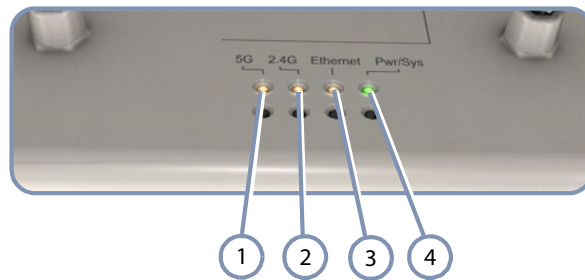

- ① 5 GHz Link/Activity LED
 - ② 2.4 GHz Link/Activity LED
- ③ LAN Link/Activity LED
 - ④ Power/System LED

Figure 25: System Status LEDs

LED	Condition	Status
Power	On Green	The system power is on.
	Blinking Green	The system is currently booting up.
	Off	System is off (no power).
LAN	On Orange	Port has a valid link.
	Blinking Orange	Indicates activity on the port.
	Off	The link is down.
2.4G	On Orange	The 802.11b/g/n 2.4 GHz radio is enabled.
	Blinking Orange	Indicates network activity.
	Off	The 2.4 GHz radio is disabled.
5G	On Orange	The 802.11a/n 5 GHz radio is enabled.
	Blinking Orange	Indicates network activity.
	Off	The 5 GHz radio is disabled.

How to Connect to the Console Port

The RJ-45 Console port on the AP is used to connect to the AP for out-of-band console configuration. The console device can be a PC or workstation running a VT-100 terminal emulator, or a VT-100 terminal. An RJ-45-to-DB-9 cable is supplied with the AP for connecting to a PC's RS-232 serial DB-9 DTE (COM) port.



Note: To connect to notebooks or other PCs that do not have a DB-9 COM port, use a USB to male DB-9 adapter cable (not included with the AP).

The following table describes the pin assignments used in the RJ-45-to-DB-9 console cable.

Table 6: Console Cable Wiring

AP's 8-Pin Console Port	Null Modem	PC's 9-Pin DTE Port
1 RXD (receive data)	<-----	3 TXD (transmit data)
3 TXD (transmit data)	----->	2 RXD (receive data)
4 SGND (signal ground)	-----	5 SGND (signal ground)

No other pins are used.

The serial port's configuration requirements are as follows:

- ◆ Default Baud rate—115,200 bps
- ◆ Character Size—8 Characters
- ◆ Parity—None
- ◆ Stop bit—One
- ◆ Data bits—8
- ◆ Flow control—none

Figure 26: Console Port Connection

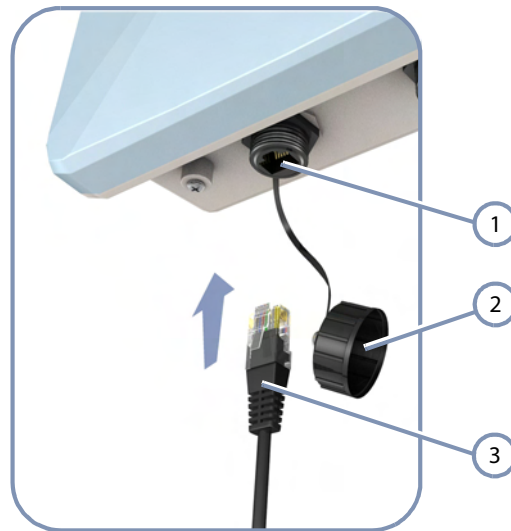

- ① RJ-45 Console Port
- ② Waterproof Port Cover
- ③ Console Cable

Follow these steps to connect to the Console port:

1. Unscrew the waterproof protective cap on the AP's Console port.
2. Attach the DB-9 end of the included serial cable to a DB-9 COM port connector on a management PC. Use a USB to male DB-9 adapter cable (not included) if needed.
3. Attach the RJ-45 end of the serial cable to the Console port on the AP.
4. Configure the PC's COM port required settings using VT-100 terminal emulator software (such as HyperTerminal) running on the management PC.
5. Log in to the command-line interface (CLI) using default settings:
 - User — admin
 - Password — *null* (there is no default password)
6. When you have completed your console session, remove the console cable and replace the waterproof cap on the connector.

For a detailed description of connecting to the console and using the AP's command line interface (CLI), refer to the *Management Guide*.



Troubleshooting

Diagnosing LED Indicators

Table 7: Troubleshooting Chart

Symptom	Action
Power LED is Off	<ul style="list-style-type: none">◆ Check connections between the PoE Power Injector, the power cord and the wall outlet.◆ Contact your dealer for assistance.
LAN LED is Off	<ul style="list-style-type: none">◆ Verify that the AP and attached PoE Power Injector are powered on.◆ Be sure the cable is plugged into both the AP and PoE Power Injector.◆ Verify that the proper cable type is used and its length does not exceed specified limits.◆ Check the cable connections for possible defects. Replace the defective cable if necessary.

System Self-Diagnostic Test Failure

If there is a failure of the system power-on-self-test (POST), you can use a console connection to view the POST results. The POST results may indicate a failed component or help troubleshoot the problem. For more information on connecting to the console port and using the CLI, refer to the *Management Guide*.

Note a POST failure normally indicates a serious hardware fault that cannot be rectified or worked around. If you encounter a POST failure, you should contact your dealer for assistance.

Power Problems

If the power indicator does not turn on when the Ethernet cable is plugged in, you may have a problem with the power outlet, power cord, or PoE power injector. However, if the unit powers off after running for a while, check for loose power connections, power losses or surges at the power outlet. If you still cannot isolate the problem, the PoE power injector may be defective.

Installation

Verify that all system components have been properly installed. If one or more components appear to be malfunctioning (such as the power cord or network cabling), test them in an alternate environment where you are sure that all the other components are functioning properly.

Wireless Connection Problems

If wireless clients cannot access the network, check the following items before you contact your local dealer for assistance:

- ◆ Be sure the AP and wireless clients are configured with the same Service Set ID (SSID).
 - ◆ Ensure that wireless clients are properly configured with the appropriate authentication or encryption keys.
 - ◆ If authentication is being performed through a RADIUS server, ensure that the clients are properly configured on the RADIUS server.
 - ◆ If authentication is being performed through IEEE 802.1X, be sure the wireless users have installed and properly configured 802.1X client software.
-

In-Band Access

If the AP cannot be configured using Telnet, a web browser, or SNMP software:

- ◆ Be sure to have configured the AP with a valid IP address, subnet mask and default gateway.
- ◆ Check that you have a valid network connection to the AP and that the Ethernet port or the wireless interface that you are using has not been disabled.
- ◆ If you are connecting to the AP through the wired Ethernet interface, check the network cabling between the management station and the AP. If you are connecting to the AP from a wireless client, ensure that you have a valid connection to the AP.
- ◆ If you cannot connect using Telnet, you may have exceeded the maximum number of concurrent Telnet sessions permitted. Try connecting again at a later time.

Out-of-Band Access

If you cannot access the on-board configuration program via a serial port connection:

- ◆ Be sure you have set the terminal emulator program to VT100 compatible, 8 data bits, 1 stop bit, no parity and 115200 Baud Rate.
- ◆ Check that the null-modem serial cable conforms to the pin-out connections provided in [“How to Connect to the Console Port”](#) on page 45.

Reset the Access Point

If all other recovery measure fail, and the AP is still not functioning properly, take any of these steps to reset the AP’s hardware:

- ◆ Enter the “reload” command from the console interface.
- ◆ Restart the AP from the web interface.
- ◆ Perform a power reset.

Index

Numerics

- 10/100 pin assignments 37
- 100BASE-T pin assignments 38

A

- AC power connection 33
- antenna position 23
- antennas, external 13

B

- basic installation tasks 18
- baud rate, console 45
- bracket kit 14

C

- cable grounding 41
- cabling guidelines 24
- chassis grounding 12, 13
- connection of system 17
- console port 12
- console port, pin assignments 45
- contents of package 16
- copper cable connection 37
- cover, weatherproof 40

D

- diagnosing LED indicators 47
- diagnostic test failure 47

E

- environmental specifications 15
- equipment checklist 16
- Ethernet RJ-45 port 12
- external antennas 13
- external antennas, mounting 27

G

- ground points 12, 13
- grounding Ethernet cable 41
- grounding the AP 31

H

- hardware errors 47
- hardware overview 11
- hardware specifications 15
- humidity specifications 15

I

- in-band access 48
- indicators, LED 36, 44
- injector module 14
- installation tasks 18
- installation troubleshooting 48
- interference, radio 24
- introduction 16

K

- key components 12

L

- LED indicators
 - port 36, 44
 - Power 44
- link status LEDs 36
- location guidelines 23

M

- management
 - out-of-band 43
 - web-based 43
- MDI, RJ-45 pin configuration 29
- mounting the AP 25

O

- operating temperature 15
- outdoor planning 24
- outdoor-rated cable grounding 41
- out-of-band access 49
- out-of-band management 43
- overview of hardware 11

P

- package contents 16
- pin assignments
 - console port 45
 - RJ-45 port 37
- planning guidelines 23
- PoE injector module 29
- PoE port 12
- pole mount bracket 14
- pole mounting 25
- port cover, weatherproof 40
- port LEDs 36
- position of AP 23
- POST failure 47
- power injector 14, 29
- power LED 44
- power problems 47
- product overview 11

R

- radio interfaces, connecting 36
- radio interference 24
- reset.AP 49
- RJ-45 connection 37
- RJ-45 port 12
- routing cables 24

S

- serial port 12
- site selection 23
- specifications, key 15
- status LEDs 36, 44
- system connections 17
- system LEDs 13, 44

T

- tasks, installation 18
- technical specifications 15
- temperature specifications 15
- test point 13
- troubleshooting LEDs 47

W

- wall mount bracket 14
- water-tight test point 13
- weather conditions 24
- weatherproof port cover 40
- web-based management 43
- wind velocity, operational 15
- wireless problems 48

Headquarters

No. 1, Creation Rd. III
Hsinchu Science Park
Taiwan 30077
Tel: +886 3 5638888
Fax: +886 3 6686111

English: Technical Support information available at www.smc.com

English: (for Asia-Pacific): Technical Support information at www.smc-asia.com

Deutsch: Technischer Support und weitere Information unter www.smc.com

Español: En www.smc.com Ud. podrá encontrar la información relativa a servicios de soporte técnico

Français: Informations Support Technique sur www.smc.com

Português: Informações sobre Suporte Técnico em www.smc.com

Italiano: Le informazioni di supporto tecnico sono disponibili su www.smc.com

Svenska: Information om Teknisk Support finns tillgängligt på www.smc.com

Nederlands: Technische ondersteuningsinformatie beschikbaar op www.smc.com

Polski: Informacje o wsparciu technicznym są dostępne na www.smc.com

Čeština: Technická podpora je dostupná na www.smc.com

Magyar: Műszaki támogatás információ elérhető -on www.smc.com

简体中文: 技术支持讯息可通过www.smc-prc.com查询

繁體中文: 產品技術支援與服務請上 www.smcnetworks.com.tw

ไทย: สามารถหาข้อมูลทางด้านเทคนิคได้ที่ www.smc-asia.com

한국어: 기술지원관련 정보는 www.smcnetworks.co.kr 을 참고하시기 바랍니다

INTERNET

E-mail address: www.smc.com → Support → By email

Driver updates: www.smc.com → Support → Downloads

SMC2890W-AN, SMC2891W-AN