

EDIFIER

Luna Eclipse

e25

Multimedia Speaker

User manual

Page1 Important safety instructions

WARNING: To reduce the risk of fire or electric shock, do not expose this apparatus to rain or moisture.

Thank you for purchasing this Edifier product. For generations, Edifier tries to provide powered speaker products to satisfy the need of our end customers, even the most demanding ones. This product can add to your home entertainment, personal computer, and mini home theater great sound performance. Please read this manual carefully to obtain the best of this system.



The lightning flash with arrowhead inside the triangle, is intended to alert the user to the presence of un-insulated dangerous voltage within the product's enclosure that may be of a sufficient magnitude to constitute a risk of electric shock to persons.



To prevent the risk of electric shock, do not remove cover (or back). No user-serviceable Parts inside. Refer servicing to qualified Service personnel only.



The exclamation point inside the triangle is intended to alert the user to the presence of important operating and maintenance (servicing) instructions in the literature accompanying the product.

1. Read these instructions.
2. Keep these instructions.
3. Heed all warnings.
4. Follow all instructions.
5. Do not use this apparatus near water.
6. Clean only with dry cloth.
7. Do not block any ventilation openings. Install in accordance with the manufacturer's instructions.
8. Do not install near any heat sources such as radiators, heat registers, stoves, or other apparatus (including amplifiers) that produce heat.
9. Do not defeat the safety purpose of the polarized or grounding-type plug. A polarized plug has two blades with one wider than the other. A grounding type plug has two blades and a third grounding prong. The wide blade or the third prong is provided for your safety. If the provided plug does not fit into your outlet, consult an electrician for replacement of the obsolete outlet.
10. Protect the power cord from being walked on or pinched particularly at plugs, convenience receptacles, and the point where they exit from the apparatus.
11. Only use attachments/accessories specified by the manufacturer.
12. Unplug this apparatus during lightning storms or when unused for long periods of time.
13. Refer all servicing to qualified service personnel. Servicing is required when the apparatus has been damaged in any way, such as power-supply cord or plug is damaged, liquid has been spilled or objects have fallen into the apparatus, the apparatus has been exposed to rain or moisture, does not operate normally, or has been dropped.
14. The MAINS plug or an appliance coupler is used as the disconnect device, the disconnect device shall remain readily operable.

FCC Caution:

"Changes or modifications not expressly approved by the part responsible for compliance could void the user's authority to operate the equipment."

FCC statement:

"This device complies with Part 15 of the FCC Rules. Operation is subject to the following two conditions:

- (1) this device may not cause harmful interference, and
- (2) this device must accept any interference received, including interference that may cause undesired operation."

Page 2 Important safety instructions

"This equipment has been tested and found to comply with the limits for a Class B digital device, pursuant to part 15 of the FCC Rules.

These limits are designed to provide reasonable protection against harmful interference in a residential installation. This equipment generates, uses and can radiate radio frequency energy and, if not installed and used in accordance with the instructions, may cause harmful interference to radio communications. However, there is no guarantee that interference will not occur in a particular installation.

If this equipment does cause harmful interference to radio or television reception, which can be determined by turning the equipment off and on, the user is encouraged to try to correct the interference by one or more of the following measures:

- Reorient or relocate the receiving antenna.
- Increase the separation between the equipment and receiver.
- Connect the equipment into an outlet on a circuit different from that to which the receiver is connected.
- Consult the dealer or an experienced radio/TV technician for help."

IC statement:

This device complies with Industry Canada license-exempt RSS standard(s). Operation is subject to the following two conditions:

- (1) this device may not cause interference, and
- (2) this device must accept any interference, including interference that may cause undesired operation of the device.

This Class **【B】** digital apparatus complies with Canadian ICES-003.

Cet appareil s'accorde avec Industrie Canada licence-exempte RSS standard.

- (1) cet appareil ne peut pas causer l'intervention, et
 - (2) cet appareil doit accepter de l'intervention, y compris l'intervention qui peut causer l'opération non désirée de.
- Cet appareil numérique de la classe B est conforme à la norme NMB-003 du Canada.



Use only with the cart, stand, tripod, bracket, or table specified by the manufacturer, or sold with the apparatus. When a cart is used, use caution when moving the cart/apparatus combination to avoid injury from tip-over.



Correct Disposal of this product. This marking indicates that this product should not be disposed with other household wastes throughout the EU. To prevent possible harm to the environment or human health from uncontrolled waste disposal, recycle it responsibly to promote the sustainable reuse of material resources. To return your used device, please use the return and collection systems or contact the retailer where the product was purchased. They can take this product for environmental safe recycling.



This equipment is a Class II or double insulated electrical appliance. It has been designed in such a way that it does not require a safety connection to electrical earth.

Page 3 Unpack the box

Box contents:

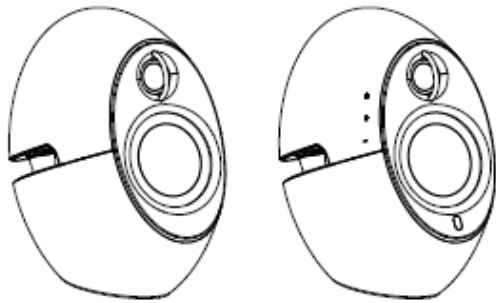

Passive speaker

Active speaker

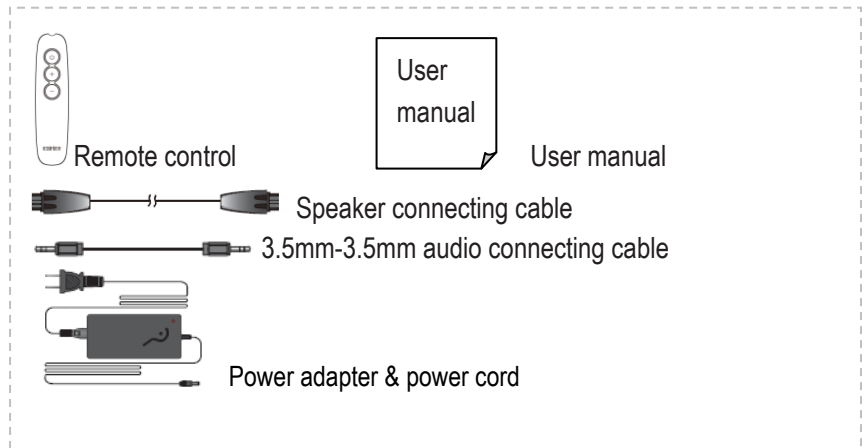

Page 4 Illustrations

Front view

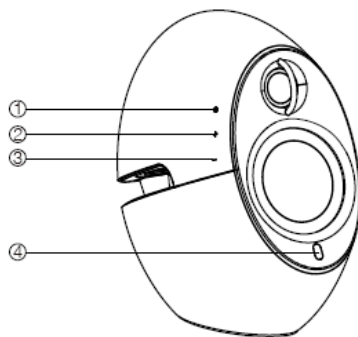

Rear view

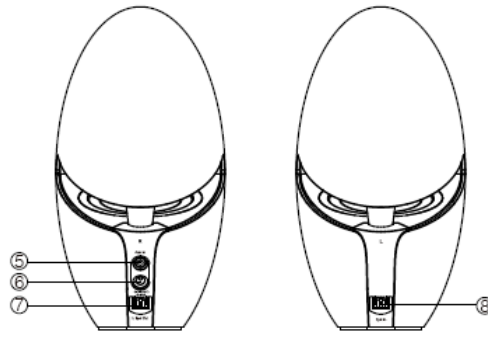

- ❶ Standby/ON
- ❷ Volume up
- ❸ Volume down
- ❹ Input indicator (blue: Bluetooth; red: AUX)
- ❺ Connect to audio connecting cable
- ❻ Connect to power adapter
- ❼ Connect to passive speaker
- ❽ Connect to active speaker



Play/Pause: Touch “⏪, +, -” at the same time briefly.



To put the system into Standby/On: Touch and hold “⏪” for approximately 2 seconds.

Remote control

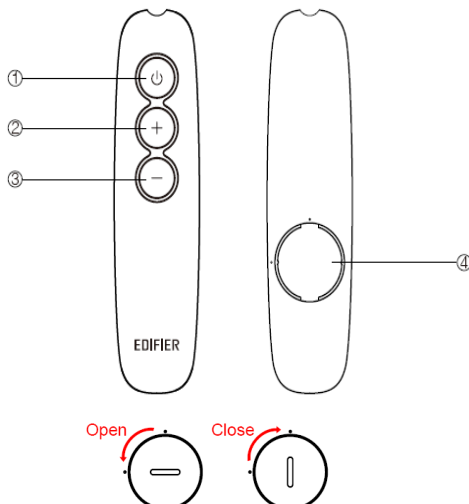

- ❶ Standby/ON
- ❷ Volume up
- ❸ Volume down
- ❹ Battery compartment

Battery loading:

Insert a coin into the slot and rotate anti-clockwise to open the battery compartment, install the new CR 2025 battery and rotate the cover clockwise to close the compartment.

Note:

1. Do not place the remote control in places that are hot and humid.
2. Do not charge the batteries.
3. Remove the batteries when unused for long period of time.
4. The battery should not be exposed to excessive heat such as direct sun, fire or similar.

Page 5 Connectivity

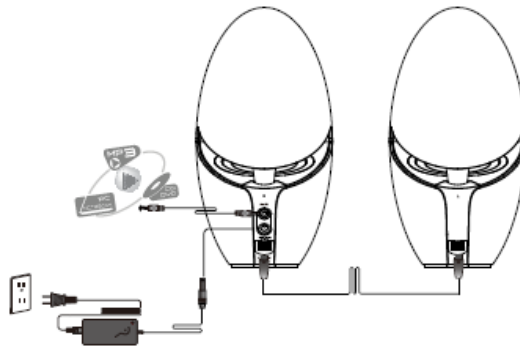

- 1 Connect the active and passive speaker with the speaker connecting cable.
- 2 Connect the power adapter to speaker and then connect to the wall socket, the system is on and the input indicator is lit.
- 3 Connect to Audio source
AUX: Connect the speaker to PC card or MP3/MP4 player, etc with the 3.5mm audio cable.
Bluetooth: Please refer to operational guide.

Page 6 Operational guide

Bluetooth®

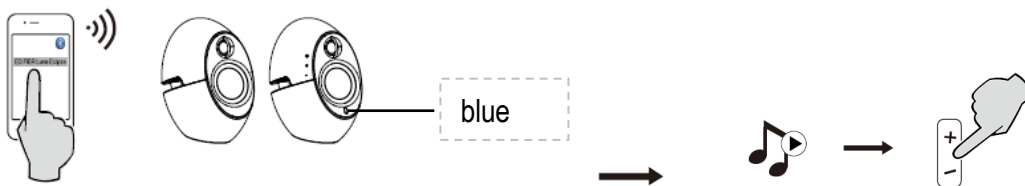

- ➔ Set your device (mobile phone, tablet device, MP3/MP4 player etc.) to search and select “EDIFIER Luna Eclipse”.
- ➔ Pair your device with “EDIFIER Luna Eclipse”.
- ➔ When the connection is made, the input indicator will change to blue.
- ➔ Play the audio on your paired device and adjust the volume to a desired level.

In Bluetooth Mode:





To skip to the next track: Slide from  to .



To revert to the previous track: Slide from  to .



To disconnect Bluetooth: Touch and hold “, , ” at the same time for approximately 2 seconds.

Note: When the Bluetooth is disconnected, the system will automatically switch to AUX mode.

Page 7 Bluetooth Troubleshooting



Bluetooth Troubleshooting

- When using audio signals from the line-in and making a switch to your Bluetooth enabled device and no audio output is produced...

→ Turn the speaker off and back on again.

● **If the indicator light is blue and there is no audio output and your Bluetooth enabled device shows that it is connected to the “EDIFIER Luna Eclipse”...**

→ Please disconnect and reconnect the Bluetooth on your Bluetooth enabled device.

Note: 1. To enjoy the full Bluetooth functions of this product, please ensure your mobile device has A2DP & AVRCP profile.

2. PIN code for connection is “0000” if needed.

Page 8 Specifications

Power output:	RMS 15W × 2 (treble) + 22W × 2(bass) (DRC ON)
Signal to noise ratio:	≥85dBA
Frequency response:	50Hz~20KHz (+/-6dB)
Input type:	Bluetooth/AUX
Input sensitivity:	600mV ± 50mV
Adjustment:	Touch keys, remote control
Bass & mid-range unit:	3 inch (82mm), 6Ω
Treble unit:	Φ19mm silk dome, magnetically shielded, 6Ω
Dimension:	122(W) × 212(H) × 222(D) mm
Weight (net/gross):	Approx. 3.6kg /4.15 kg

Page 9 Troubleshooting

- Switch the EDIFIER Luna Eclipse off then on and reconnect to the audio source.
- Ensure Bluetooth function is enabled compatible on your Bluetooth devices.
- Move the devices closer and retry the connection.
- Try another Bluetooth device for connection.
- Please check if power is connected, and if the wall outlet is switched on.
- Please switch the system off then on and reconnect to the audio source.
- Please check if the system is in STBY.
- Please check if the master volume is turned to minimum.
- Please check if the audio input cable is connected correctly.
- Please check if there is signal from audio source.
- Keep a 0.2 ~1m distance between the speaker system and monitor or TV set to avoid magnetic interference.

If you have any further questions or concerns regarding EDIFIER Products...

Asia, Europe, Oceania:

📄 Please visit our website at: www.edifier.com, or email EDIFIER Support for further assistance at: main@edifier.com,

→ Dear Customer, thank you for purchasing this EDIFIER product. For the EDIFIER warranty applicable for this product, we refer you to the Edifier website www.edifier-international.com/warranty-terms.

Canada/USA/Mexico: www.edifier.ca, Email: service@edifier.ca

☎ If you prefer, you may contact us by phone, Toll Free: 1-877-EDIFIER (334-3437) in Canada, 1-800-688-7406 in US.

South America: Please visit www.edifier.com (English) or www.edifierla.com (Spanish/Portuguese) for detailed local contact information.