

# ELECRAFT® KPA500

## 500-WATT AMPLIFIER

### OWNER'S MANUAL

Draft, March 3, 2011

Copyright © 2011, Elecraft, Inc.

All Rights Reserved

# Contents

Key to Symbols and Text Styles.....	3
Installation .....	4
Operation .....	7
Power On .....	7
Band Switching .....	8
Transmitting .....	8
Monitoring .....	9
Fault Conditions .....	10
Menu.....	11
Firmware Updates.....	12
Specifications.....	13
Customer Service and Support .....	14
Theory of Operation .....	15

## Key to Symbols Abbreviations and Text Styles

 **Important – read carefully**

 Operating tip

 *Tap* switch function (labeled *above* a switch)

 *Hold* switch function (labeled *below* a switch; hold for 1/2 sec. to activate)

**LED** Light Emitting Diode

**LCD** Liquid Crystal Display

# Installation

The following text uses braces to refer to numbered elements in the front- and rear-panel illustrations below. For example, {1} refers to ①, the RF OUTPUT connector.

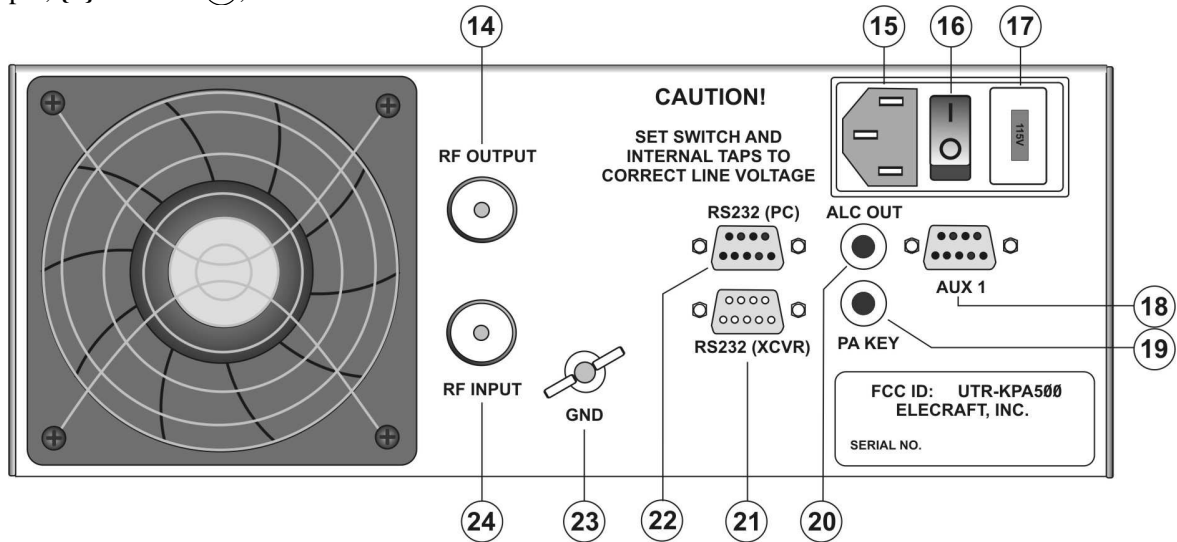

Figure 1. KPA 500 Rear Panel

## Mains Voltage Settings

### ⚠ CAUTION!

**Do not connect mains power to your KPA500 or attempt to turn it on before setting the fuse block switch and internal jumpers to match your supply voltage as described below; otherwise you may do extensive damage to your amplifier.**

1. Check to ensure the fuse block {4} is set for either 120 VAC or 240 VAC to match your mains voltage. The current voltage setting is shown in the red window. If needed, change the fuse block setting as follows:
  - Open the door covering the fuse block and then carefully pry the red fuse block out of the holder as shown below:

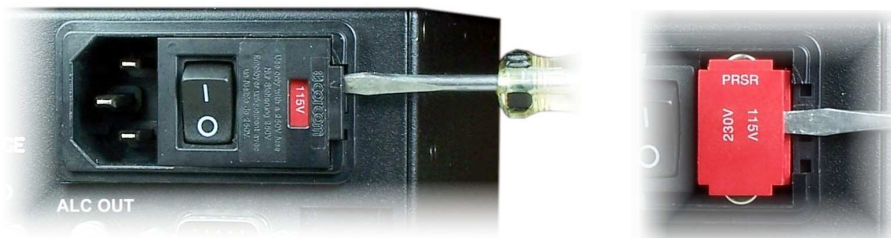

- Install the proper fuses in the block. Use 12A fuses for 115V and 6A fuses for 230V.
- Replace the fuse block so that the correct mains voltage appears in the window in the cover.

2. Set the internal transformer tap for the specific voltage within the 120 or 240 VAC ranges as follows:
  - Remove the 14 screws securing the KPA500 top cover as shown below. Do not remove the screw indicated. It is part of the safety interlock switch mechanism. Lift the top cover off.

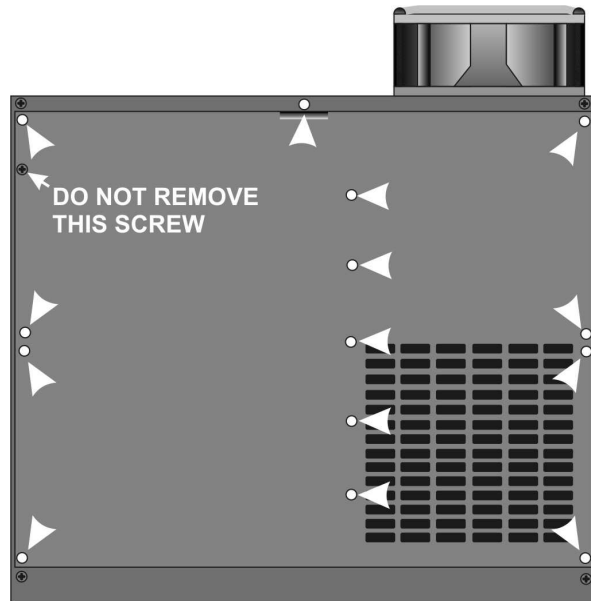

- Three taps are provided via red, green and yellow wires. Choose the tap according to the actual mains voltage at the outlet you plan to use for the KPA500. If you cannot measure your mains voltage, use the yellow tap.

115V Nominal Mains	TAP	230V Nominal Mains
95V to 105V	GREEN	190V to 210V
106V to 115V	RED	211V to 230V
115V to 125V	YELLOW	231V to 250V

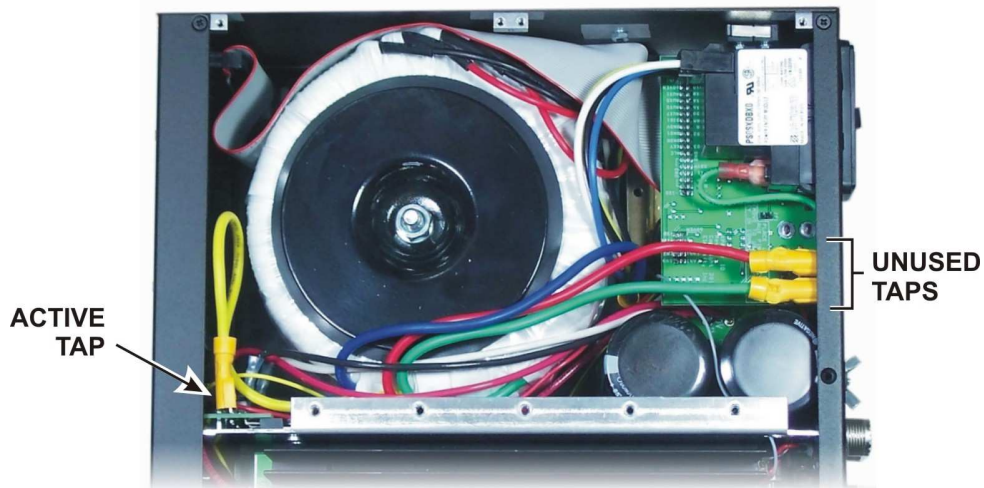

- Be sure to place the unused taps side-by-side on the terminals at the back panel as shown. Do not leave them floating loose inside the unit.
- Replace the top cover before proceeding. An interlock switch prevents operating the amplifier with the top cover removed.

3. Test the power supply voltage output as follows:
  - Connect the mains supply cable to {15} on the rear panel and plug the cable into the mains outlet. (At this point this may be the only cable connected to the rear panel.)
  - Position the rear-panel power switch to On (I).
  - Tap the front panel **ON** switch. The LCD should light.
  - Tap the **HV** switch ({3} on Figure 2) and note the voltage displayed on the LCD. It must be between 65 and 80 volts. If it is outside of this range, immediately tap the **ON** switch to turn the KPA500 off, and position the rear panel power switch to Off (O). Open the top cover again and select a different transformer tap. If the voltage was too low, select a tap further up the list in the above table. If the voltage was too high, select a tap further down the table.

**NOTE:** If the red FAULT LED lights when you tap the **ON** switch, that indicates the power supply voltage is above the upper limit. Use a power transformer tap lower on the above table and retry the test.

## Cabling

1. Connect your station ground to the GND thumbscrew {10}. A good station ground is important for safety and to minimize local radio frequency interference (RFI).
2. Attach the RF INPUT {11} to the output of your driving transceiver or transmitter using a 50 ohm coaxial cable with an PL-259 male connector on the KPA500 end. The driving transmitter must supply up to 40 watts for full output from the KPA500.
3. Attach the RF OUTPUT {1} to a suitable load with an SWR of less than 1.5:1. A dummy load is strongly recommended for initial testing.
4. Connect the PA KEY {8} to the driving transmitter Key Output. This line must be grounded to transmit, and 1 mA of current is sourced. The KPA500 PA KEY jack is pulled up to 5VDC when not transmitting.
5. **Optional:** If the driving transceiver is an Elecraft K3, connect AUX1 {5} to the AUX connector on the K3 using the optional cable. This cable is not required to operate your KPA500. It allows full use of the control functions on the K3. **Note: This is not a common VGA computer cable.**
6. **Optional:** RS232 (PC) connects the KPA500 to your personal computer with a standard 9-pin serial cable. Required for updating the KPA500 firmware.
7. **Optional:** RS232 (XVCR) connects the KPA500 to a Kenwood transceiver using a standard 9-pin serial cable.
8. **Optional:** ALC OUT {6} provides level information to control the driving transmitter RF level. The output is negative-going from -4 VDC to -9VDC.

**⚠ IMPORTANT:** Position the amplifier so there is at least 2 inches (5 cm) clearance behind and above the amplifier for proper air flow.

# Operation

## Power On

1. Ensure a suitable 50 ohm load is attached to the RF OUTPUT connector on the rear panel (Figure 1, {1}). A dummy load is strongly recommended for initial tests.
2. Enable the power supply by pressing the rear panel rocker switch (Figure 1, {3}) to the On (I) position.

### **⚠ IMPORTANT**

Switches with a legend above and below the pushbutton have two functions. **Tap** (*press briefly*) to activate the function labeled **above** a switch. **Hold** to activate the function labeled **below** the switch. In the text, *tap* functions are shown like this: **TEMP**. An example of a *hold* function is **PK HOLD**.

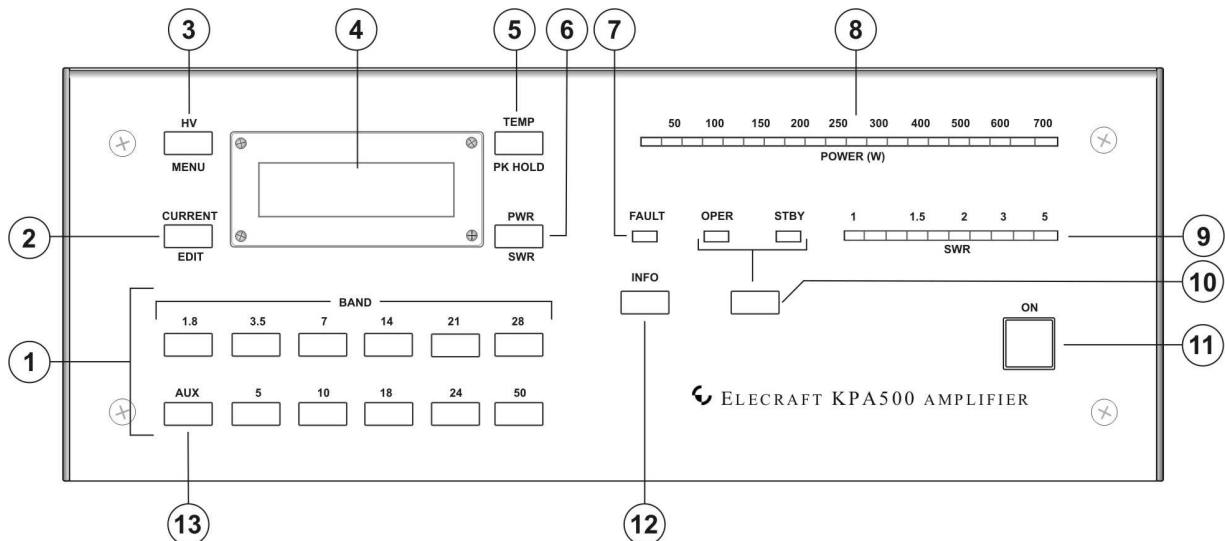

Figure 2. KPA500 Front Panel.

3. Tap the ON switch. The LCD {4} and STBY LED should light.

**⚠ NOTE:** If at any time the FAULT LED {7} lights, refer to *Fault Conditions*, pg. 10.

## Band Switching

**Automatic Band Switching:** The KPA500 automatically measures the frequency of the RF drive and selects the proper band. The PA KEY input must be connected to the driving transmitter.

**Manual Band Switching:** Tap any of the front-panel BAND switches to select that band.

### Coordinated Transmitter and KPA500 Band Switching:

- The KPA500 will follow the band selected on a K3 transceiver when the AUX cable is attached between the KPA500 AUX connector and K3 AUX connector. (pg 6.)
- Tapping a BAND switch on the KPA500 will cause the driving K3 transceiver to change bands accordingly when the AUX cable is connected.

**⚠ Important:** The automatic band selection function is active whenever PA KEY is low (in transmit mode) and overrides band selection made by any other means to protect the KPA500 from damage by wrong-band operation.

## Transmitting

1. Tap the OPR/STBY switch {10} and confirm the STBY LED goes out and the OPER LED lights.
2. Apply a few watts of RF drive and note that the POWER (W) LEDs illuminate to indicate the RF output power.
3. Increase the drive power and confirm that the SWR LEDs indicate less than 1.5 while the output indicated by the POWER (W) LEDs increases. For ease in reading the critical SWR levels, the SWR LEDs are green from 1 to 1.5. The 1.5 to 2.1 SWR LEDs are yellow and the LEDs for SWRs above 2.1 are red. Up to 40 watts of drive is required to produce the full 500 watts output from the KPA500.

**⚠ Important:** Never exceed 40 watts of drive to the KPA500 at any time.



## Monitoring

KPA500 operation is monitored by the LEDs {7}, {8} and {9} and reported in text on the LCD.

### LEDs

Standing wave ratio (SWR) of the load and output power are displayed on LED bar graphs. The bar graphs are color-coded: green for normal operating range, yellow for marginal levels and red for excessive levels. Excessive levels may trigger a fault and shut the KPA500 off (see *Fault Conditions* below). A red LED lights if a fault condition occurs. Also two green LEDs indicate whether the amplifier is in standby (STBY) or operating (OPER) mode.

### LCD

Normally the LCD displays the band currently selected. The four switches around the LCD select other information to be displayed on the screen and the behavior of the LEDs. Note that these switches have both tap and hold functions (pg 7). Repeat the tap or hold action to return the LCD to the band display.

- **HV** {3} displays the PA voltage on the LCD. Must be between 65 and 80 V when the KPA500 is in standby (STBY) .
- **CURRENT** {2} displays the PA current on the LCD. Must never exceed 20 A.
- **TEMP** {5} displays the heat sink temperature on the LCD. Must be less than 90C.
- **PWR** {6} displays the output power numerically on the LCD. Must not exceed 650 W
- **MENU** {3} displays the menu system (see pg. 11).
- **EDIT** {2} enables editing menu parameters (see pg. 11).
- **PK HOLD** {5} toggles the peak power output display on the bar graph. When enabled, the LED corresponding to the peak power output remains lighted for 1 second.
- **SWR** {6} displays the load SWR numerically on the LCD. ~~Must not exceed 2:1.~~

## Fault Conditions

The FAULT indicator {7} lights to indicate a fault condition has occurred and the KPA500 is automatically switched to standby mode.

Tapping the **INFO** switch displays a text description of the fault condition on the LCD.

### *Low Level Faults*

If the FAULT indicator is blinking, one of the following low level faults has occurred and will clear automatically when the condition is corrected.

<b>Fault</b>	<b>Cause/Correction</b>
Over Drive	RF Drive > 40 Watts / Reduce RF drive to the KPA500
Over Output	Excessive RF Output / Reduce RF Drive to KPA500.
High Reflected Power	Reflected Power > 60 Watts
Invalid Frequency	Frequency counter detected transmissions in a restricted frequency band. Amp is automatically bypassed until the counter detects this error has been corrected.

### *High Level Faults*

If the indicator is on steady, one of the following high-level faults has occurred and the KPA500 has automatically switch to STBY mode. Clear the fault, then tap the OPR/STBY switch to resume operation.

<b>Fault</b>	<b>Cause/Correction</b>
HV Error	Top Cover Interlock Switch Open / Replace and secure KPA500 top cover.
Over Drive	RF Drive > 40 Watts over a period of time, or over 60 Watts momentarily. / Reduce RF drive to the KPA500
Over Temp	Power Amp Heat Sink > 90°C / Check to ensure top and rear air vents clear.
Over Current	Excessive Current to Power Amplifier / Check and reduce SWR.
High Reflected Power	Reflected power > 60W for an extended period of time or > 100W momentarily.
Open Load	Indicated SWR > 18:1
Over Dissipation	Finals are dissipating more than 600W of heat

## Menu

Holding **MENU** {3} enables the menu function to allow the following parameters to be set. With the menu function enabled, the MENU, EDIT and switches next to the  $\triangle$  and  $\nabla$  symbols all respond to a simple tap. Use the  $\triangle$  and  $\nabla$  switches to scroll through the menu items. Tap **EDIT** and the  $\triangle$  and  $\nabla$  switches to select the parameter and tap **MENU** again to save the parameter and again to exit the menu.

Entry	Default	Description	Notes
ALC THR	-4	ALC Threshold Adjustment	
ATTN REL	1	Attenuator Release Time in Seconds/8	
FAN CTL	NOR	Minimum Fan Speed	Allows fan to turn off when not needed.
FW REV		Displays firmware revision	
LCD ADJ	50	LCD Contrast Adjustment	
LCD BRT	6	LCD Backlight Brightness	
LED BRT	6	LED Brightness Adjustment	
PWR ADJ	100	Wattmeter Calibration	By-band calibration factor
RADIO	K3	Specifies driving transceiver model	
RS232 A	38400	Serial Port A Speed in Baud	
RS232 B	38400	Serial Port B Speed in Baud	
TR TIME	0	QSK Delay Time	Slows T>R release time. For transceivers with poor transmit timing characteristics

## Firmware Updates

New features and improvements are available to all KPA500 owners via firmware upgrades.

Please visit the Elecraft K3 software page ([www.elecraft.com](http://www.elecraft.com)) to obtain our free firmware download application, *KPA500 Utility*. Versions of the Utility program are provided for PCs, Macs, and Linux platforms.

**⚠ Some applications or peripheral devices may interfere with P3 downloads; check the Help information in *KPA500 Utility* if you have difficulty.**

If you don't have Internet access, you can obtain a firmware upgrade on CD. If you don't have a computer, you can send your P3 to Elecraft to be upgraded. See Customer Service, pg.14.

### Checking your Firmware Revision

Use the MENU entry *FW Rev* to determine your firmware revision.

### Updating K3 Firmware

# Specifications

<b>Frequency Range</b>	All Amateur Bands from 1.8 to 29.7 MHz and 50 to 54 MHz
<b>Supply Voltage and Current</b>	100 to 125 VAC or 200 to 250 VAC, 50/60 Hz, approx. 1000 VA
<b>Weight</b>	26 lbs
<b>Size</b>	Enclosure only, 4.0 x 10.7 x 10.0 in., HWD (10.2 x 27.2 x 25.4 cm). With projections, 4.4 x 11.1 x 11.8 in. (11.2 x 28.2 x 30.0 cm)
<b>Power Output</b>	500 watts
<b>Duty Cycle at 500 Watts</b>	10 minutes key down / 5 minutes off
<b>Drive Power</b>	30 to 40 watts for 500 watts output
<b>Input VSWR</b>	Less than 1.5:1
<b>ALC Out</b>	Negative-going, adjustable.
<b>Metering</b>	Power Output, SWR (bargraph and on the LCD display), supply voltage and current, temperature, frequency band.
<b>SWR</b>	TBD
<b>PA Current</b>	20A maximum
<b>PA Voltage</b>	60 VDC, nominal
<b>Heat Sink Temperature</b>	90°C, maximum
<b>Key In</b>	+5V open circuit on receive, closed to ground on transmit (1 mA max.)
<b>Efficiency</b>	Approximately 50%

# Customer Service and Support

## *Technical Assistance*

You can send e-mail to [k3support@elecraft.com](mailto:k3support@elecraft.com) and we will respond quickly – typically the same day Monday through Friday. If you need replacement parts, send an e-mail to [parts@elecraft.com](mailto:parts@elecraft.com). Telephone assistance is available from 9 A.M. to 5 P.M. Pacific time (weekdays only) at 831-763-4211. Please use e-mail rather than calling when possible since this gives us a written record of the details of your problem and allows us to handle a larger number of requests each day.

## *Repair / Alignment Service*

If necessary, you may return your Elecraft product to us for repair or alignment. (Note: We offer unlimited email and phone support, so please try that route first as we can usually help you find the problem quickly.)

**IMPORTANT: You must contact Elecraft before mailing your product** to obtain authorization for the return, what address to ship it to and current information on repair fees and turn around times. (Frequently we can determine the cause of your problem and save you the trouble of shipping it back to us.) Our repair location is different from our factory location in Aptos. We will give you the address to ship your kit to at the time of repair authorization. *Packages shipped to Aptos without authorization will incur an additional shipping charge for reshipment from Aptos to our repair depot.*

## **Elecraft 1-Year Limited Warranty**

This warranty is effective as of the date of first consumer purchase (or if shipped from the factory, the date the product is shipped to the customer). It covers both our kits and fully assembled products. For kits, before requesting warranty service, you should fully complete the assembly, carefully following all instructions in the manual.

**Who is covered:** This warranty covers the original owner of the Elecraft product as disclosed to Elecraft at the time of order. Elecraft products transferred by the purchaser to a third party, either by sale, gift, or other method, who is not disclosed to Elecraft at the time of original order, are not covered by this warranty. If the Elecraft product is being bought indirectly for a third party, the third party's name and address must be provided at time of order to ensure warranty coverage.

**What is covered:** During the first year after date of purchase, Elecraft will replace defective or missing parts free of charge (post-paid). We will also correct any malfunction to kits or assembled units caused by defective parts and materials. Purchaser pays inbound shipping to us for warranty repair; we pay shipping to return the repaired equipment to you by UPS ground service or equivalent to the continental USA and Canada. For Alaska, Hawaii, and other destinations outside the U.S. and Canada, actual return shipping cost is paid by the owner.

**What is not covered:** This warranty does not cover correction of kit assembly errors. It also does not cover misalignment; repair of damage caused by misuse, negligence, or builder modifications; or any performance malfunctions involving non-Elecraft accessory equipment. The use of acid-core solder, water-soluble flux solder, or any corrosive or conductive flux or solvent will void this warranty in its entirety. Also not covered is reimbursement for loss of use, inconvenience, customer assembly or alignment time, or cost of unauthorized service.

**Limitation of incidental or consequential damages:** This warranty does not extend to non-Elecraft equipment or components used in conjunction with our products. Any such repair or replacement is the responsibility of the customer. Elecraft will not be liable for any special, indirect, incidental or consequential damages, including but not limited to any loss of business or profits.

# Theory of Operation

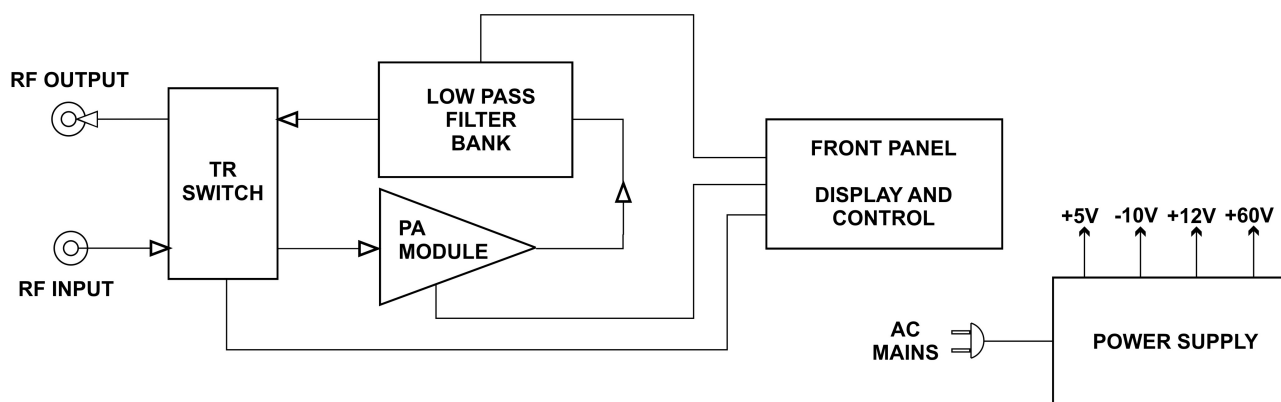

When the KPA500 is in Operating (OPER) mode, RF is routed by the Transmit-Receive (TR) switch to the Power Amplifier (PA) module where it is amplified by a pair of VRF2933 FETs.

The PA module output is routed to the Low Pass Filter (LPF) bank input. The LPF bank provides filters for each frequency band. The frequency of the incoming signal is monitored and the appropriate filter is automatically switched into the signal path. The filter also may be selected by band data provided by the transceiver or by front panel switches on the KPA500. However, the automatic selection based on the incoming signal frequency over-rides either of those inputs to ensure the correct bandpass filter is always in the signal path.

The output of the LPF bank is routed to the RF Output via the TR Switch.

During receive or when the KPA500 is in Standby (STBY), the TR switch routes the RF Input directly to the RF Output, bypassing both the PA Module and the Low Pass Filter Bank.

The MCU in the Display and Control module monitors and makes critical measurements of a number of operating conditions including two levels of fault conditions that automatically alter the operation of the KPA500:

1. If an undesirable, but not critical, fault conditions occurs, a 3 dB attenuator is switched in line with the PA input and the red FAULT LED is blinked at a 1 Hz rate to alert the operator. An example of such a fault is overdriving the KPA500 input. When the fault is corrected, such as reducing the driving power, the 3 dB attenuator is switched out automatically and FAULT light stops blinking.
2. If a critical fault occurs, the amplifier is automatically switched to STANDBY, passing the RF drive directly through to the RF Output. The red FAULT LED is lighted continuously and the fault conditions are displayed on the front panel.

# INTERFACE CABLES

## **Aux Connector**

The KPA500 AUX connector has the following pin assignment.

(PINOUT TABLE)

## **AUX Interface Cable**

An optional interface cable is available for Elecraft K3 users. The pin assignments are as follows.

(PINOUT TABLE)



# KIT ASSEMBLY PROCEDURE

TBD