

Electronic Solutions, Inc.
T24A-Pdual with RR24 connected to RP24
Operation & Installation Manual
March 7, 2002

Specifications:

T24A-Pdual Transmitter

Power Supply Voltage 3V (2 AAA batteries)

Frequency 418 MHz

RR24 Receiver

Power Supply Voltage 5V (provided via RP24)

RR24 Installation Guide

Connect the RR24 Radio Receiver to the RP24 as shown

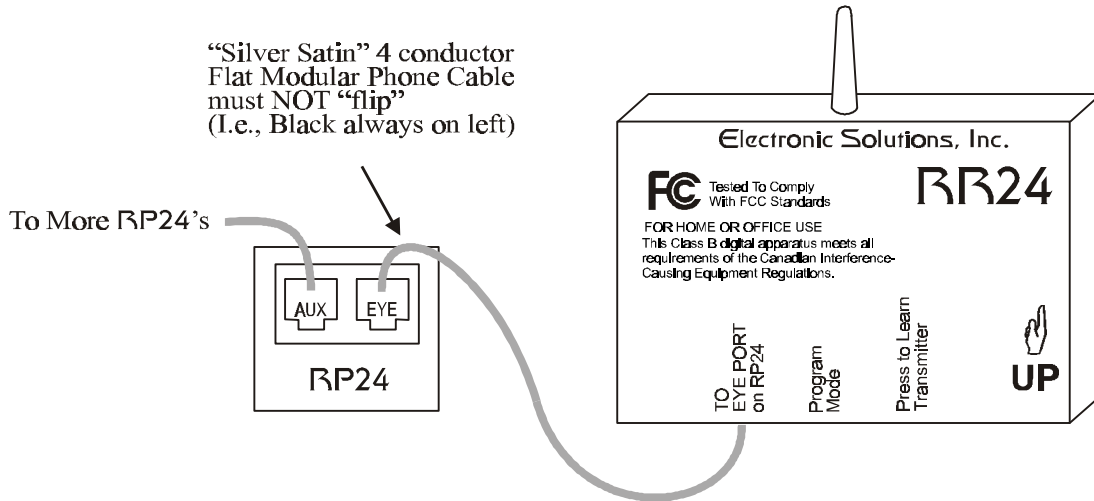

The RR24 unit must connect to an Eye Jack on a RP24 or splitter. If the eye connects to a splitter, then the Main jack next to it **must** connect to the Eye Jack on an RP24.

For best reception, the RR24 should be mounted with the antenna pointing up, and it should not be placed on or near a metal surface.

The RR24 unit can learn up to 5 different transmitters to work with. It ships from the factory with NO transmitters learned, you must train it in the field to work with your specific transmitters.

Press and release the “Learn Transmitter” button on the RR24, the red LED will come on if 5 transmitters have not already been learned, the unit is now ready to learn another radio transmitter:

Press stop on the radio transmitter, (buttons other than stop are ignored)

The LED on the RR24 will go out,
this transmitter is added to the list of known transmitters,
the RR24 is now operating normally again.

Note that if this transmitter is already known, this button will be ignored and the LED will remain lit.

If no stop command is received within 10 seconds,
the red LED will flash off, then on, and then go out. NO new transmitters were learned!
(Note that if no transmitters are known at all, then the LED will turn back on immediately)

If the red LED is on and the learn button is pressed and released,
the red LED will turn off with no changes to the learned list.
(Note that if no transmitters are known at all, then the LED will turn back on immediately)

If no transmitters are known, (as shipped from factory)
then the red LED will turn on as soon as the unit is plugged in.
Note that the LED will flash every 10 seconds until a transmitter is learned.
Pressing the learn button has no meaning while in this mode (the LED will turn off while the button is pushed).

Press and hold the learn button for 5 seconds to clear all known transmitters, (the LED will blink on and off.)
Release the button, the red LED will come on, and the unit is ready to learn the 1st transmitter.

3/7/02

If you press and release the learn button and the LED does not come on, the list is “full” and no more transmitters can be learned.

Note that in the learn mode (button is pressed or the LED is on), the receiver is not passing commands to the RP24 system. Once the transmitter is learned, and if the STOP button is still held, the stop command will be sent to the system.

INSTRUCTION TO THE USER

This equipment has been tested and found to comply with the limits for a class B digital device, pursuant to part 15 of the FCC Rules. These limits are designed to provide reasonable protection against harmful interference in a residential installation. This equipment generates, uses and can radiate radio frequency energy and if not installed and used in accordance with the instructions, may cause harmful interference to radio communications. However, there is no guarantee that interference will not occur in a particular installation. If this equipment does cause harmful interference to radio or television reception, which can be determined by turning the equipment off and on, the user is encouraged to try to correct the interference by one or more of the following measures:

- * Reorient or relocate the receiving antenna.
- * Increase the separation between the equipment and receiver.
- * Connect the equipment into an outlet on a circuit different from that to which the receiver is connected.
- * Consult the dealer or an experienced radio/TV technician for help.

The user is cautioned that change and modifications made to the equipment without the approval of manufacturer could void the user's authority to operate this equipment.