

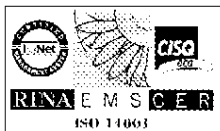

CAV/15U
UHF - CAV TV System
User's manual



Registration number: **IT-17686**



Registration number: **IT-24436**

CE 0682 

SS 96 Km 113
70027 Palo del Colle (Ba) **ITALY**
Tel. +39 (0)80 626755
Fax +39 (0)80 629262
E-mail: elettronika@elettronika.it
Web site: <http://www.elettronika.it>

Index	3
Warning	5
Warranty	6
Introduction	7
Content of the manual	7
Treatment of electrical shock	9
<i>First-aid</i>	10
<i>Treatment of electrical burns</i>	10
<i>Note</i>	10
Section 1 - Information	13
1.1 <i>Description</i>	14
1.2 <i>Technical characteristics</i>	16
1.3 <i>Block diagram</i>	18
Section 2 - Installation	19
2.1 <i>Operating environment</i>	20
2.2 <i>Preliminary operations</i>	20
2.3 <i>Telemeasuring socket connections</i>	21
2.4 <i>RS232 Socket connections</i>	21
2.5 <i>Menu description</i>	22
2.6 <i>Protection thresholds, alarms and settings</i>	24
2.7 <i>Channel change procedure</i>	24
2.8 <i>Preventive maintenance</i>	25
<i>Front panel</i>	26
<i>Rear panel</i>	27
Section 3 - Diagram	29
<i>MTF0100AR0 Amplifier module - Component list</i>	30
<i>SCH0291AR0 (Mother board)</i>	31
- <i>Calibration points</i>	46
- <i>Adjustment points description</i>	46
- <i>Video baseband section check</i>	50
- <i>Audio baseband section verification</i>	51
- <i>Intermediate Frequency section check</i>	52
- <i>Up-Converter check</i>	55
- <i>General section calibration</i>	55
- <i>External AGC operation</i>	56

<i>SCH0123AR1 (Control board and display)</i>	57
- <i>Adjustment points calibration</i>	60
<i>SCH0136AR0 (IV-VBd VCO Integrated)</i>	61
- <i>Adjustment points calibration</i>	61
<i>MTG0050AR0 (40dB UHF Filter)</i>	64
- <i>Calibration procedure</i>	64
<i>SCH0300AR0 (Interface board)</i>	67
<i>SCH0312AR0 (2W Amplifier module)</i>	69
<i>SCH0316AR0 (20W Amplifier module)</i>	70
<i>E0004 (S-150-24 Switching power supply)</i>	71

WARNING

The apparatus described in this manual has been designed and manufactured with devices to safeguard the users. In any case it is recommended that during any operation of installation, maintenance, miscellaneous interventions and calibrations requiring the apparatus to be switched on,

THE USER TAKES ALL THE PRECAUTIONS AGAINST INCIDENTS

It is required to use the proper clothes and protection gloves in order to prevent damages from incidental contacts with high-voltage parts.

The manufacturer declines every responsibility in case the recommendations above are not followed.

IMPORTANT

The component lists attached to the relevant electrical diagrams indicate for each item the reference, the description and the type normally used.

The *Elettronika S.r.l.* though reserves the right to use or supply as spare parts components with equivalent characteristics but of a different type, assuring anyway the optimal work of the apparatus in accordance with the specifications.

The enclosed monographs are solely owned by *Elettronika S.r.l.*

The use of anything enclosed in this technical manual without explicit authorization given by *Elettronika S.r.l.* will be prosecuted by the law.

The data and technical characteristics of the apparatus described in this manual are not compelling for the manufacturer.

The *Elettronika S.r.l.* reserves the right to make, without previous notice, modifications or updates in order to improve the quality of the product.

The general conditions of supply and sale are described in the contracts.

The delivery time are in accordance with the products and quantities ordered.

Summary of warranty

We, ELETTRONIKA S.r.l., SS096 Km 113 Z.I. PALO DEL COLLE (BA) ITALY, warrant to the ORIGINAL PURCHASER of a NEW product, for a period of one (1) year from the date of purchase by the original purchaser (the "warranty period") that the new ELETTRONIKA product is free of defects in materials and workmanship and will meet or exceed all advertised specifications for such a product. This warranty does not extend to any subsequent purchaser or user, and automatically terminates upon sale or other disposition of our product.

Items excluded from this ELETTRONIKA warranty

We are not responsible for product failure caused by misuse, accident, or neglect. This warranty does not extend to any product on which the serial number has been defaced, altered, or removed. It does not cover damage to loads or any other products or accessories resulting from ELETTRONIKA product failure. It does not cover defects or damage caused by use of unauthorized modifications, accessories, parts, or service.

What we will do

We will remedy any defect, in material or workmanship (except as excluded), in our sole discretion, by repair, replacement, or refund. If a refund is elected, then you must make the defective or malfunctioning component available to us free and clear of all liens or other encumbrances. The refund will be equal to the actual purchase price, not including interest, insurance, closing costs, and other finance charges less a reasonable depreciation on the product from the date of original purchase. Warranty work can only be performed at our authorized service centers or at our factory. Expenses in remedying the defect will be borne by ELETTRONIKA, including one-way surface freight shipping costs within the United States. (Purchaser must bear the expense of shipping the product between any foreign country and the port of entry in the United States and all taxes, duties, and other custom's fee(s) for such foreign shipments).

How to obtain warranty service

You must notify us of your need for warranty service not later than ninety (90) days after the expiration of the warranty period. We will give you an authorization to return the product for service. All components must be shipped in a factory pack or equivalent which, if needed, may

Disclaimer of consequential and incidental damages

You are not entitled to recover from us any consequential or incidental damages resulting from any defect in our product. This includes any damage to another product or products resulting from such a defect.

Warranty alterations

No person has the authority to enlarge, or modify this warranty. The warranty is not extended by the length of time for which you are deprived of the use of the product. Repairs and replacement parts are provided under the terms of this warranty shall carry only the unexpired portion of this warranty.

Design changes

We reserve the right to change the design of any product from time to time without notice and with no obligation to make corresponding changes in products previously manufactured.

Legal remedies of purchaser

There is no warranty which extends beyond the terms hereof. This written warranty is given in lieu of any oral or implied warranties not contained herein. We disclaim all implied warranties, including without limitation any warranties of merchantability or fitness for a particular purpose. No action to enforce this warranty shall be commenced later than ninety (90) days after expiration of the warranty period.

Warranty for electronic tubes

The warranty applied for electronic tubes is the one given by the manufacturer of the tube. In the event that the product shows anomalies within the deadline of the validity of the warranty given by the manufacturer of the product itself, the buyer will have to return it to the seller with the needed documents and the written description of the defect. The seller will ship the broken tube to the manufacturer in order to effect the necessary technical tests to find out the cause of the anomaly. Meanwhile the buyer of the tube who needs to use, and as such to replace immediately the product, will have to buy a new one and provide to the relevant payment, further to the issuing by the seller of a regular commercial invoice. After the adequate tests made by the manufacturer, should the result be positive, that is confirm the defect in manufacturing, the seller will issue a regular credit note in the name of the buyer and return the amount paid. Should the result be negative, that is detect a negligence in the installation or use by the buyer, he will have no right against the seller.

INTRODUCTION

The apparatus described in this manual is the latest of this series, offering high performances, remarkable reliability and a wide range of characteristics, it all at a low cost.

Its is easy to install and use. It only takes to follow the installation procedure as shown in this manual: after having removed all from the package, you only have to follow step by step the description in the various sections.

Before starting to use the apparatus, remember to:

- read carefully the general safety information contained in this section;
- follow the instructions for the installation and set up of the apparatus;
- read all the remaining sections of this manual in order to know well the apparatus and learn how to obtain the best of its characteristics.

CONTENTS OF THE MANUAL

The chapter composing this manual contain all the information concerning the use of the apparatus. For more information refer to ELETTRONIKA S.r.l.

This manual is made up of different chapters, each made up of various sections. Each individual chapter represents a single apparatus composing the whole station.

WARNING!

The currents and voltages in this equipment are dangerous!
Personnel must at all times observe safety regulation!

This manual is intended as a general guide for trained and qualified personnel who are aware of the dangers inherent in handling potentially hazardous electrical and electronic circuits. It is not intended to contain a complete statement of all safety precautions which should be observed by personnel in using this or other electronic equipment.

The installation, operation, maintenance and service of this equipment involves risks both to personnel and equipment, and must be performed only by qualified personnel exercising due care. Elettronika S.r.l. shall not be responsible for injury or damage resulting from improper procedures or from the use of improperly trained or inexperienced personnel performing such tasks.

During installation and operation of this equipment, local building codes and fire protection standards must be observed.

WARNING!

Always disconnect power before opening covers, doors, enclosures, gates, panels or shields.
Always use grounding sticks and short out high voltage points before servicing. Never make internal adjustments, perform maintenance or service when alone or when fatigued.

Do not remove, short-circuit or tamper with interlock switches on access covers, doors, enclosures, gates, panels or shields.
Keep away from live circuits, know your equipment and don't take chances.

WARNING!

In case of emergency ensure that power has been disconnected.

Treatment of electrical shock

1) If victim is not responsive follow the A, B, C's of basic life support.

PLACE VICTIM FLAT ON HIS BACK ON A HARD SURFACE

A - AIRWAY

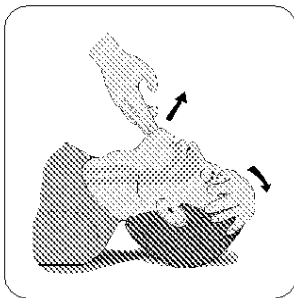

If unconscious, open airway lift up neck, push forehead back, clear out mouth if necessary, observe for breathing.

B - BREATHING

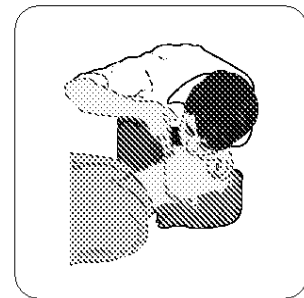

If not breathing, begin artificial breathing. Tilt head, pinch nostrils, make airtight seal, 4 quick full breaths. Remember mouth to mouth resuscitation must be commenced as soon as possible.

C - CIRCULATION

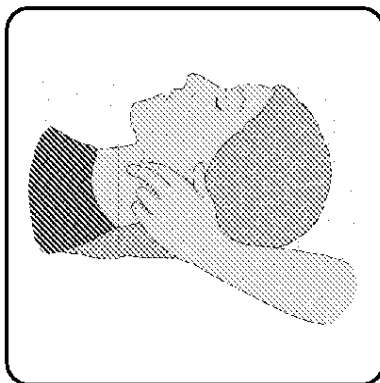

Check carotid pulse. If pulse absent, begin artificial circulation.

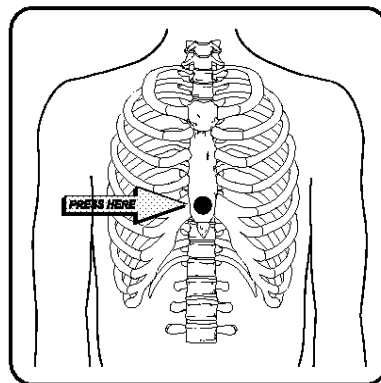

Approx. 80sec.: 1 rescuer, 15 compressions, 2 quick breaths.

Approx. 60sec.: 2 rescuers, 5 compressions, 1 breath.

NOTE: DO NOT INTERRUPT RHYTHM OF COMPRESSIONS WHEN SECOND PERSON IS GIVING BREATH.

Call for medical assistance as soon as possible.

2) If victim is responsive:

- keep them warm;
- keep them as quiet as possible;
- loosen their clothing (a reclining position is recommended).

FIRST-AID

Personnel engaged in the installation, operation, maintenance or servicing of this equipment are urged to become familiar with first-aid theory and practices. The following information is not intended to be a complete first-aid procedure, it is brief and is only to be used as a reference. It is the duty of all personnel using the equipment to be prepared to give adequate Emergency First Aid and thereby prevent avoidable loss of life.

TREATMENT OF ELECTRICAL BURNS

1) Extensive burned and broken skin.

- Cover area with clean sheet or cloth (cleansed available cloth article);
- do not break blisters, remove tissue, remove adhered particles of clothing, or apply any salve or ointment;
- treat victim for shock as required;
- arrange transportation to a hospital as quickly as possible;
- if arms or legs are effected keep them elevated.

NOTE

If medical help will not be available within an hour and the victim is conscious and not vomiting, give him a weak solution of salt and soda: 1 level teaspoonful of salt and 1/2 level teaspoonful of baking soda to each quart of water (neither hot or cold).

Allow victim to sip slowly about 4 ounces (half a glass) over a period of 15 minutes.

Discontinue fluid if vomiting occurs (do not give alcohol).

2) Less severe burns - (1st & 2nd degree).

- Apply cool (not ice cold) compresses using the cleansed available cloth article;
- do not break blisters, remove tissue, remove adhered particles of clothing, or apply salve or ointment;
- apply clean dry dressing if necessary;
- treat victim for shock as required;
- arrange transportation to a hospital as quickly as possible;
- if arms or legs are affected keep them elevated.

UHF - CAV TV SYSTEM

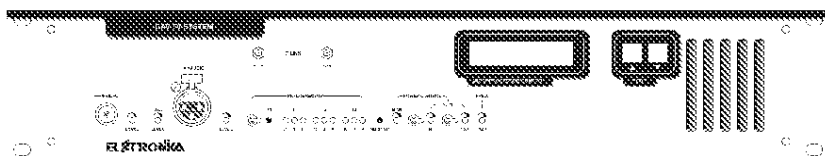

CAV/15U

User's manual

This page is intentionally blank

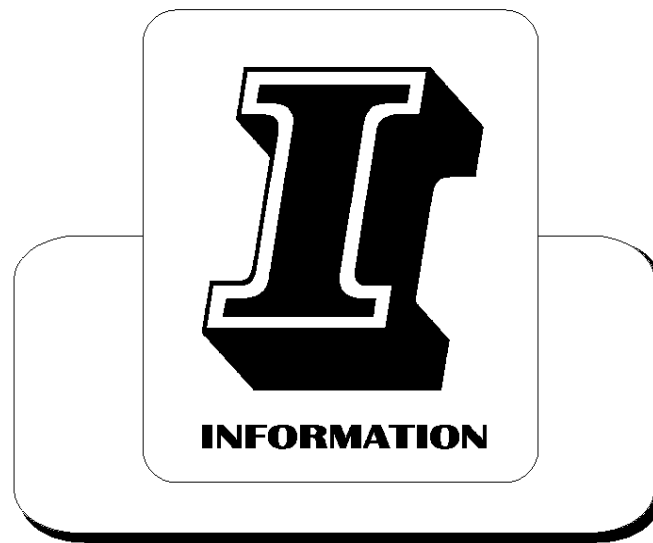

Section 1 - Information

Contents:

- 1.1 Description*
- 1.2 Technical characteristics*
- 1.3 Block diagram*

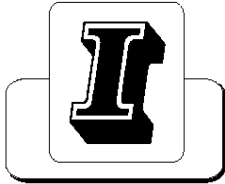

CAV/15U

UHF - CAV TV SYSTEM

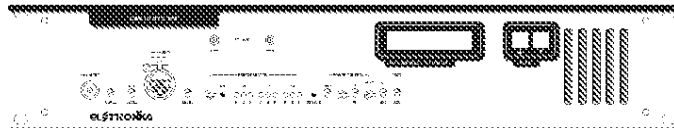

1.1 DESCRIPTION

One of the goals while designing this apparatus was to obtain an apparatus easy to mount and in the logistic disposition of its components, yet aesthetically pleasant and functional. In detail:

- the filter and amplification stage has been made compact, while keeping a good ventilation to limit working temperature, by mounting it all on a single heat sink with a bent steel conveyor;
- all the linear voltage-stabilization stages on the mother board, as well as the temperature sensor, are placed on a staff mounted directly on the heat sink of the final stage, both to use the latter to cool the devices and to monitor its temperature without the need of additional wires;
- all connectors and controls placed on the frontal panel are directly connected to the mother board;
- the connections between the mother board and the control board are made through a single 20-pin connector;
- the power supply of the final stage is made through the mother board which includes the shunt to measure the current absorbed by this stage;
- all wiring between the mother board and the other sections of the apparatus is made with detachable connectors (see clamps for power supply and control of the final stage) to make repair easier;
- the output connector of the transmitter, the air inlet of the cooling system of the final stage, the power supply box including the main switch and fuses, the telemeasuring connector and the external reference input, if any, have been placed on the back of the apparatuses.

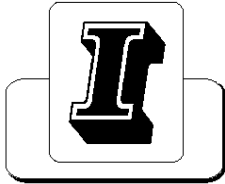

Main features:

- Rack 19"-2U.
- Power supply: 115/230Vac 50/60Hz.
- Indication of the main parameters on LCD display (*Forward and Reflected power, Audio modulation, Synchronism level, Heat sink temperature, PLL control voltage, Power supply voltage and current absorbed by the final stage*).
- Alarm thresholds for FWD Power ($P_{out} + 20\%$), REF Power ($20\% P_{out}$) and Temperature (70°C).
- Power supply input on IEC box with double fuse on the check.
- RF output with N connector on the rack.
- Video input with BNC connector on the frontal.
- Audio input with XLR connector on the frontal panel.
- IF link with SMB connector on the frontal panel.
- Level adjustment (Video, Audio, SC) with multi-turn trimmer on front panel.
- Three cell pre-corrector, disabled from front panel.
- Automatic or manual gain control on front panel.
- Graphic 2Rx16C display with two selection keys and buzzer.

WARNING!!!

THE MONITOR SOCKET MUST ONLY BE USED FOR QUALITY MEASURES, IT MUST NOT BE USED FOR VERIFICATION OF AMPLITUDE AND PRESENCE OF SPURIOUS.

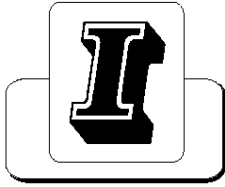

1.2 TECHNICAL CHARACTERISTICS

RF

Frequency range	470 - 860MHz
Output power	0 to 15W (Adj.)
Output power control	Automatic or Manual (switch-Selected)
Local oscillator	2,5ppm (option 0,05ppm)
I.M.D	< -60dB (with IF Pre-corrector)
Spurious and Harmonics level	< -60dB
RF Output connector	N Female
RF Output impedance	50Ω

VIDEOSECTION

Input	75Ω
Nominal level	1V _{pp} ±6dB
Return loss	> = 30dB up to 5MHz
DC Recovery	Clamped to back porch
White limitation	90%... 115% not affecting crominance
Group delay pre-corrector	8 Cells
Group delay	< = 50ns (with professional vestigial filter)
Frequency response	< = ±0.5dB
Differential gain	< = ±5%
Differential phase	< = ±5°
Luminance non-linearity	< = 5%
S/HUM Ratio	> = 45dB weighted
S/N Ratio	> = 65dB weighted, > = 55dB unweighted
Black level variation	< = 2%
2T K Factor	< = 1%
ICPM	< = 2°
IF	32.7MHz... 45.75MHz
IF Level (on external link)	-15dBm... -10dBm

AUDIOSECTION

Input	600Ω/10kΩ balanced
Nominal level	2.2V _{pp} -10dB++6dB
Pre-emphasis	FLAT, 50μs, 75μs
Low-pass filter	15kHz, 100kHz
Limitation circuit	Δ _{nom} +1dB
Frequency response	< = 0.5dB
THD	< = 0.5%
Intermodulation	d2< = -60dB, d3< = -60dB
S/N FM CCIR Ratio	> = 60dB weighted
	> = 60dB unweighted (ref. 50kHz)
S/N AM Ratio	> = 70dB asynchronous
	> = 50dB synchronous (ref. 100%)
IF	30.5MHz... 41.25MHz
IF Level (on external link)	Adjustable

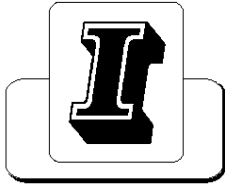

LOCAL OSCILLATOR

Frequency	50MHz..900MHz splitted between bands I, III, IV/V
Offset	±32kHz max
Frequency stability	±2.5ppm (-5°C... +45°C)
External reference	5MHz
Output level (on mixer)	7dBm ±1dB
S/N FM CCIR Ratio	> = 60dB weighted > = 60dB unweighted (ref. 50kHz)

GENERAL

Power supply	110/230VAC, ± 10%, 50/60Hz
Cabinet	Rack 19"-2U
Dimensions	482,6x88x400mm
Weight	10kg
Ambient temperature	-5° to +45°C
Humidity	20% - 90%

PROTECTION THR.

FWD Power	6W ($P_{NOM} + 20\%$)
REF Power	1W ($20\% P_{NOM}$)
Temperature	70°C (on heatsink)

Block Diagram

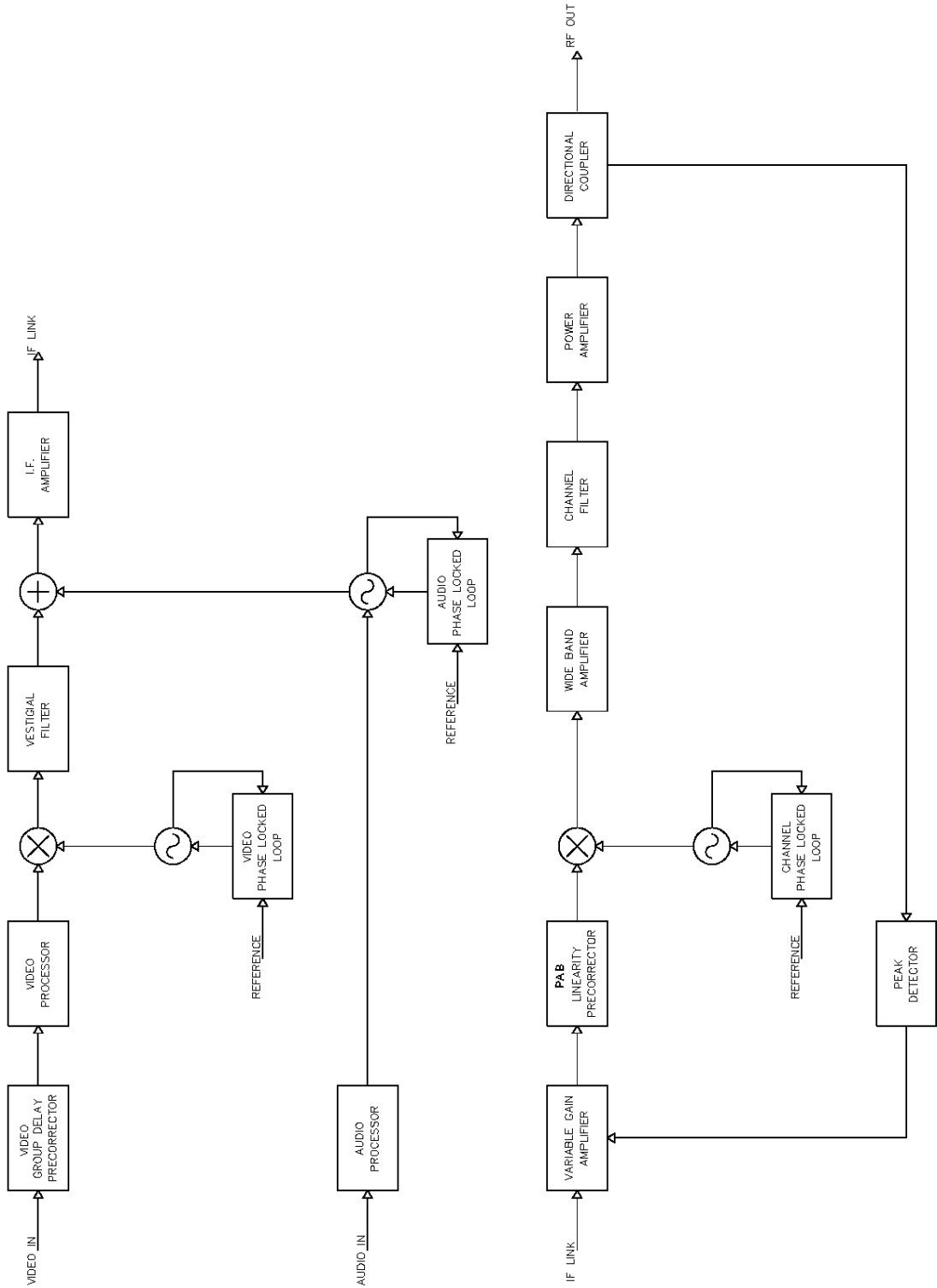

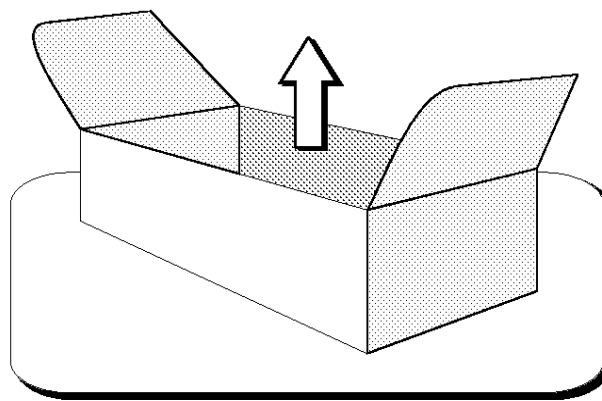

Section 2 - Installation

Contents:

- 2.1 Operating environment*
- 2.2 Preliminary operations*
- 2.3 Telemeasuring socket connections*
- 2.4 RS232 Socket connections*
- 2.5 Menu description*
- 2.6 Protection thresholds, alarms and settings*
- 2.7 Channel change procedure*
- 2.8 Preventive maintenance*
 - Front panel*
 - Rear panel*

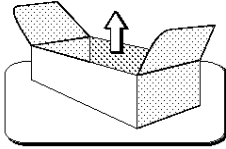

2.1 OPERATING ENVIRONMENT

The apparatus can be installed in a standard component rack or on a suitable surface such as a bench or desk. In any case, the area should be as clean and well-ventilated as possible. Always allow for at least 2 cm of clearance under the unit for ventilation. If you set the apparatus on a flat surface, install spacers on the bottom cover plate. If you install the apparatus in a rack, provide adequate clearance above and below. Do not locate the apparatus directly above a hot piece of equipment.

2.2 PRELIMINARY OPERATIONS

Correct installation of the equipment is important for maximum performance and reliability. Antenna and earth connections must be installed with the greatest care. The equipment adjustment isn't need, because the unit is completely adjusted by our technical staff. This is the installation procedure:

1. connect the power supply cable of the transmitter to the electric network. If the transmitter is to be connected to an amplifier, the power supply cable of the transmitter has to be connected to the auxiliary socket of the amplifier and the power supply cable of the amplifier to the electric network;
2. connect the antenna cable on the rear panel.

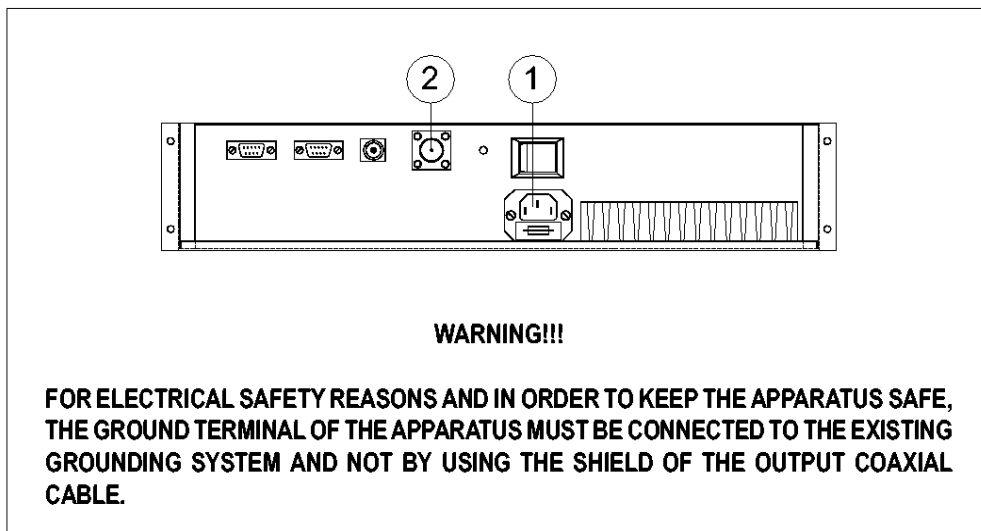

3. Connect audio/video cables to the input connectors on the front panel.

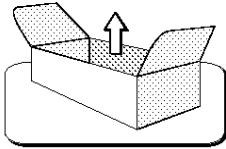

WARNING!!!

FOR ELECTRICAL SAFETY REASONS AND IN ORDER TO KEEP THE APPARATUS SAFE, THE GROUND TERMINAL OF THE APPARATUS MUST BE CONNECTED TO THE EXISTING GROUNDING SYSTEM AND NOT BY USING THE SHIELD OF THE OUTPUT COAXIAL CABLE.

2.3 TELEMEASURING SOCKET CONNECTIONS

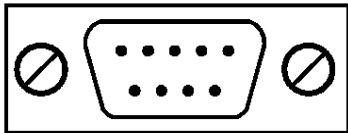

DB9 Socket

PIN N°	SIGNAL TYPE	IN / OUT	FUNCTION
1	GND	-	-
2	GND	-	-
3	GND	-	-
4	GND	-	-
5	GND	-	-
6	Analog	Output	Reflected Power
7	Analog	Output	Forward Power
8	Digital	Output	GND= Alarm Floating= OK
9	Digital	Input	GND= OFF 5V or Floating= ON

2.4 RS232 SOCKET CONNECTIONS

PIN	1	2	3	4	5	6	7	8	9
FUNCTIONS	-	Tx	Rx	-	GND	-	-	-	-

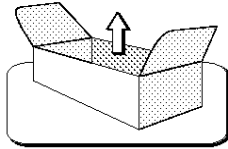

2.5 MENU DESCRIPTION

TV Transmit. 15W Software V 2.0	Type of apparatus and installed software version indication
Standard G - H	Transmission standard indication
Sync Meter ██████████	Synchronism level indication
Audio Meter ██████████	Audio level indication
FWD Power 15W ██████████	Output signal forward power indication
REF Power 0W ██████████	Output signal reflected power indication
Temperat. 35.0°C ██████████	Amplifier heat-sink temperature indication
PLL conv. Lock ██████████	Local oscillator status indication

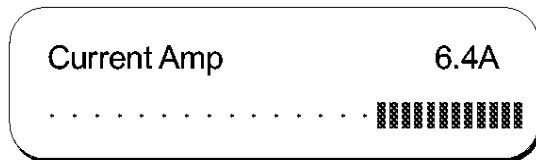
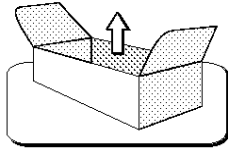

Amplifier absorbed current indication

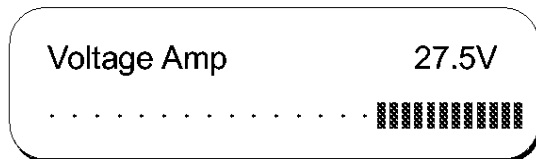

Amplifier power supply voltage indication

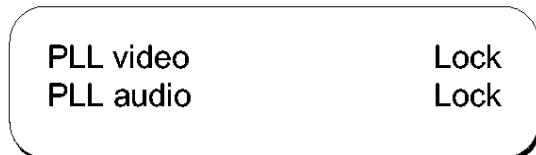

IF oscillators status indication

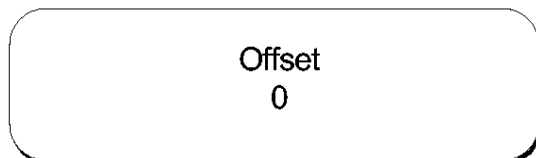

OFFSET indication

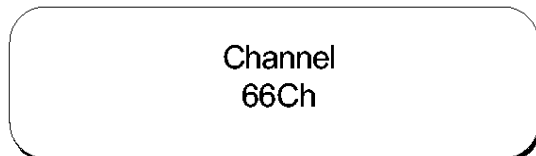

Transmission channel indication

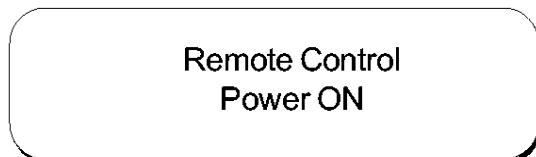

Remote Control status indication

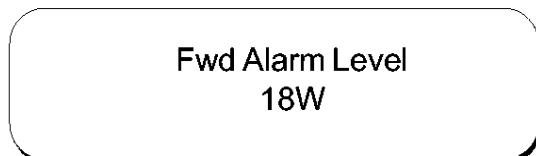

Forward Alarm level indication

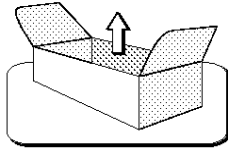

2.6 PROTECTION THRESHOLDS, ALARMS AND SETTINGS

In case of breakdown or unlock of one of the PLLs, the power of the transmitter is automatically decreased to zero and the “ALARM” indication is shown on the display, which then automatically enters the menu of the faulty parameter. When the alarm disappears, the transmitter is turned on again. After five ON/OFF cycles, the transmitter is blocked with a “FAULT” indication on the parameter which caused the stop.

Only the STANDARD, transmission CHANNEL, OFFSET and REMOTE ENABLED parameters can be set.

In order to set them, perform the following steps:

- remove the jumper called JP1 from the board;
- press many times the left key to choose the parameter to be set;
- once the parameter has been selected, press the right key to confirm. The set parameter starts blinking;
- choose the new value to be set by pressing the left key;
- once the value has been chosen, press the right key to confirm;
- place again the previously removed jumper JP1.

Note: after the STANDARD parameter has been modified, you will be asked to modify the transmission CHANNEL parameter as well.

WARNING!!!

**THE SETTING OF THE STANDARD AND TRANSMISSION CHANNEL PARAMETERS
MUST BE PERFORMED BY SKILLED PERSONNEL ONLY,
SINCE THEY REQUIRE A RECALIBRATION OF THE FILTERS.**

2.7 CHANNEL CHANGE PROCEDURE

1. Remove JP1 from the boards SCH0123AR1 (Setting mode)
2. Select the "Standard" menu by scrolling the display with the left key and confirm with the right key (not needed to change the channel only). Select the desired standard with the left key and confirm with the right key.
3. In the "Channel" menu, select the desired channel by scrolling with the left key and confirming with the right

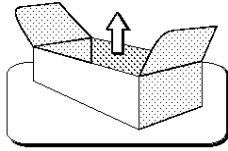

key.

4. Reposition JP1 on SCH0123AR1 (Display mode).
5. Scroll the "PLL CONV" menu to display the lock voltage of the PLL.
6. Adjust C20 (fine) and C31 (coarse) on SCH0136AR0 to lock the PLL ("lock" indication on the display and lock voltage in the middle).
7. Re-tune the channel filter MTG0050AR0 as per the calibration procedure.

2.8 PREVENTIVE MAINTENANCE

To ensure maximum performance and minimum repair trouble, we strongly recommend you to follow the below stated guidelines for preventive maintenance:

1. check the antenna installation and ground connection at regular intervals;
2. keep your apparatus clean and dry externally: this will ensure continuous functioning of the front panel controls;
3. if the apparatus has not been used for a long period of time combined with exposure to extreme environmental conditions, open the unit and make a visual inspection.
Remove salt, water or ice with a moist cloth before turning the apparatus on. Check that the cooling fans are running freely.
4. for general maintenance and top performance, call an authorized service technician to give the apparatus and the complete antenna/earth connection installation a general check each 12-18 months;
5. check at regular intervals that the air intake located on the front panel is free of dust. If there is visible dust, remove it by means of a soft brush.

Front panel

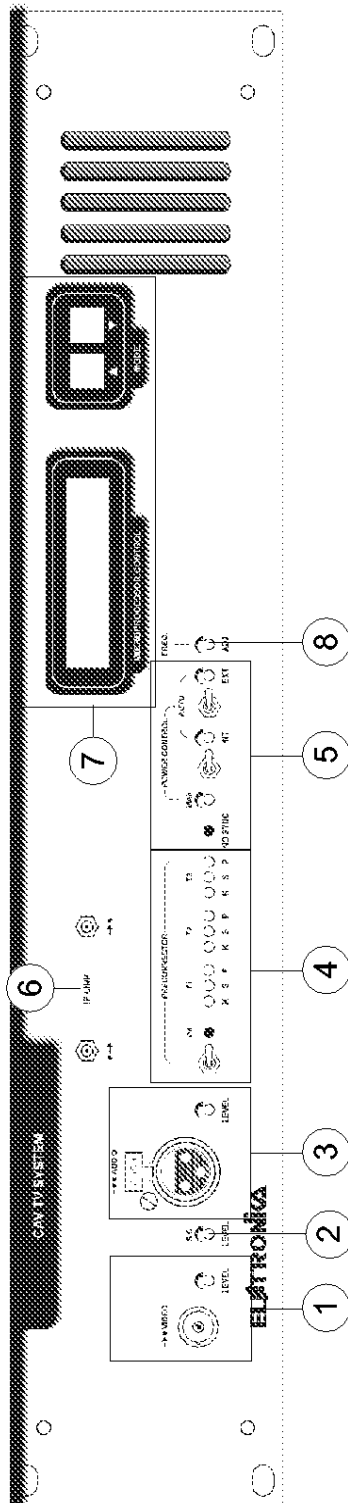

DESCRIPTION

1	Video section 75Ω BNC Video input 1Vpp ±6dB adjustable
2	Sound carrier level adjustment
3	Audio input 10k/600Ω Bal/Unbal Audio input 1Vpp adjustable
4	Three-cell linearity pre-corrector
5	Automatic / Manual level control -3dB Output power with no sync
6	IF (-15dBm) Link
7	Microprocessor control readings <ul style="list-style-type: none"> - FWD Power level with alarm - REF Power level with alarm - Audio meter - Sync meter - IF Carrier lock status with alarm - L.O. Carrier lock status and Lock voltage indication with alarm - Heatsink temperature with alarm - RF Power amplifier operating point - Output power, standard, channel, offset
8	Frequency Adj.

Rear panel

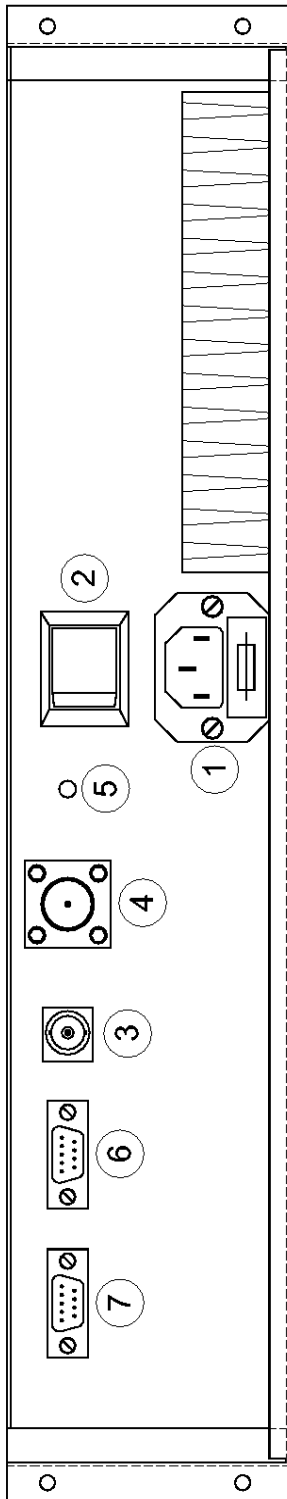

DESCRIPTION

1	Power supply socket with Fuse
2	Main switch
3	RF Input connector
4	RF Output connector
5	GND
6	Telemeasuring socket
7	RS232 Socket

This page is intentionally blank

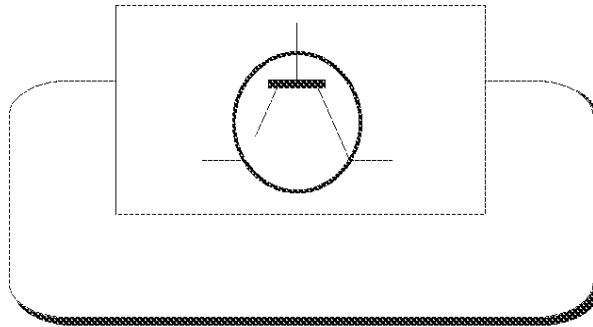

Section 3 - Diagram

Contents:

- *MTF0100AR0 Amplifier module - Component list*
- *SCH0291AR0 (Mother board)*
- *SCH0123AR1 (Control board and display)*
- *SCH0136AR0 (IV/VBd VCO Integrated)*
- *MTG0050AR0 (40dB UHF Filter)*
- *SCH0300AR0 (Interface board)*
- *SCH0312AR0 (2W Amplifier module)*
- *SCH0313AR0 (20W Amplifier module)*
- *E0004 (SP-150-24 Switching power supply)*

Component list**MTF0100AR0 Amplifier module**

Part Name Code	Description	Qty
SCH0300AR0	INTERFACE BOARD	1
SCH0312AR0	2W UHF AMPLIFIER MODULE	1
SCH0316AR0	20W UHF AMPLIFIER MODULE	1
01400	C.PAS. 2499-003-X5U0-102M	1
01403	C.PAS. TF418.452E 102XG300M00-VDC	3
02512	SMA SOCKET WITHOUT BATTERY J01151A0531	1
02514	SMA SOCKET REAR PANEL R114553000	3
SCA0093	COVER FOR VEGA AMPLIFIER MODULE	1
SCA0095	BOX FOR 15W CAV	1
DET1044	DET1044R0 HEATSINK FOR 15W CAV	1

Component layout SCH0291AR0

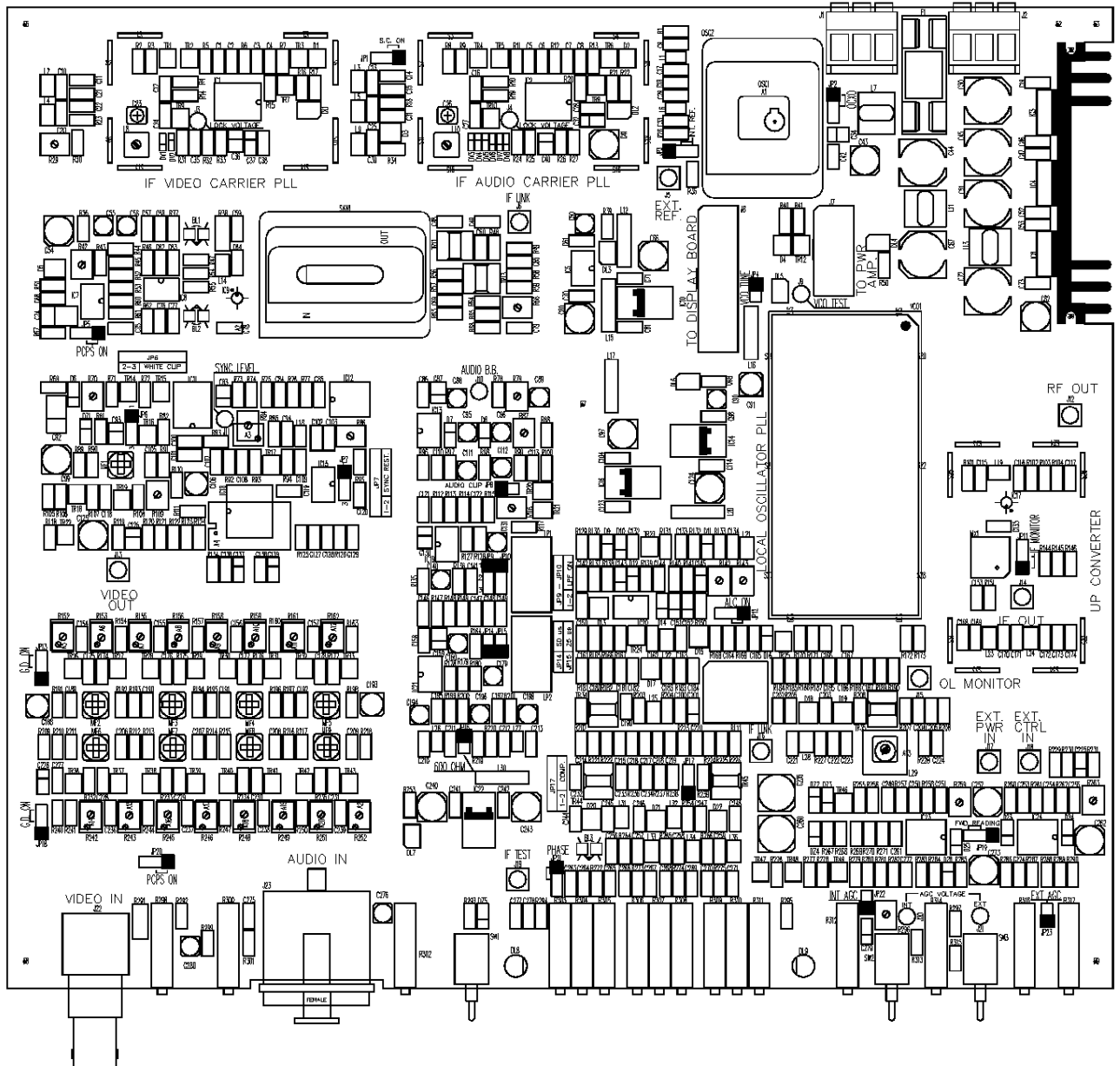

COMPONENT LIST SCH0291AR0

Part Name/Number	Description	Qty.	Comps.	Page 1/5
257BLR-3618N05010	05010 FILTRO AUDIO TOKO	2	LP1-2	
CC 100nF-S 01065C	01065C Y5V 1206 COND	57	C3, C7, C19, C28, C35, C38, C42, C46-47, C52-53, C61, C68, C70-71, C73, C75, C81, C84-86, C98, C101-104, C108, C114, C118, C120-121, C123, C128-129, C132-134, C136, C144, C158, C189-192, C200, C206-209, C217-218, C227, C241-242, C250, C254, C261	
CC 100pF-S 01092	01092 SMD 1206 COND	7	C113, C116-117, C127, C135, C153-154	
CC 10nF-S 01053B	01053B SMD 1206 COND	20	C1, C5, C48, C57-60, C64, C69, C77-79, C142, C161, C216, C224, C234, C249, C263, C265	
CC 10pF-S 01086	01086 SMD 1206 COND	9	C12, C16, C24, C27, C29, C169, C173, C236, C277	
CC 1206 N.M.	N.M. SMD 1206 COND	2	C100, C232	
CC 120pF-S	01030A SMD 1206 COND	4	C15, C21, C105, C231	
CC 12pF-S 01087	01087 SMD 1206 COND	2	C62-63	
CC 15pF-S 01088	01088 SMD 1206 COND	2	C171, C237	
CC 18pF-S 01089	01089 SMD 1206 COND	2	C20, C25	
CC 1nF-2%-S 01041D	01041D SMD 1206 COND	3	C147-149	
CC 1nF-S 01096	01096 SMD 1206 COND	53	C2, C6, C39, C76, C115, C141, C150, C162-167, C174, C180, C182-187, C199, C202-205, C214-215, C219-223, C228, C244-248, C251, C253, C255-257, C264, C266-271, C275, C278	
CC 1uF100V-S 01760A	01760A Y5V 1206 COND <<50 V>>	4	C4, C8, C272, C274	
CC 220pF-S 01093	01093 SMD 1206 COND	2	C119, C230	
CC 22pF-S 01090	01090 SMD 1206 COND	5	C9, C33, C107, C175, C238	
CC 27pF-S 01022B	01022B SMD 1206 COND	4	C210-213	
CC 2p2F-S 01081B	01081B SMD 1206 COND	1	C49	
CC 330pF-S 01094	01094 SMD 1206 COND	2	C94, C109	
CC 33pF-S 1023A	1023A SMD 1206 COND	4	C10, C13, C168, C172	
CC 39pF-S 1024A	1024A SMD 1206 COND	2	C18, C239	
CC 470pF-S 01095	01095 SMD 1206 COND	1	C229	
CC 47pF-S 01100	01100 SMD 1206 COND	11	C65, C110, C122, C138, C146, C157, C176, C195, C197, C258-259	
CC 4p7F-S 01083	01083 SMD 1206 COND	1	C17	
CC 56pF-S 01091	01091 SMD 1206 COND	5	C156, C170, C177, C181, C233	
CC 68pF-S 01027A	01027A SMD 1206 COND	5	C11, C14, C22, C31, C155	
CC 82pF-S 01028A	01028A SMD 1206 COND	1	C178	
CE 100uF16V-S 01792A	01792A ELETTR SMD COND	3	C54, C99, C125	
CE 100uF25V-S 01793B	01793B ELETTR SMD COND	2	C235, C260	
CE 10uF16V-S	01626B TANT. ELETTR SMD CO	12	C32, C37, C137, C139, C143, C145, C151-152, C201, C225-226, C279	
CE 10uF16V-S 01776A	01776A ELETTR SMD COND	19	C50, C55-56, C88-90, C95-96, C111-112, C131, C140, C160, C179, C194, C196, C198, C276, C280	
CE 10uF35V-S 01778A	01778A ELETTR SMD COND	4	C91, C106, C188, C193	

Part Name/Number	Description	Qty.	Comps.	Page 2/5
CE 1uF35V-S 01613A	01613A TANT. ELETTR SMD CO	9	C34, C36, C40, C83, C87, C93, C126, C130, C159	
CE 220uF50V LOWESR	01799A ELE. SMD COND LOW	6	C30, C44-45, C51, C67, C72	
CE 22uF35V-S 01782A	01782A ELETTR SMD COND	3	C252, C262, C273	
CE 47uF 16V-S	01636A TANT. ELETTR SMD CO	2	C74, C92	
CE 47uF35V-S 01790A	01790A ELETTR SMD COND	8	C43, C66, C80, C82, C97, C124, C240, C243	
CED6 N.M.	N.M. ELETTR SMD COND	1	C41	
CV 6.5-30pF-S 01482	01482 VARIABLE COND	1	C23	
CV 8.5-40pF-S 01483	01483 VARIABLE COND	1	C26	
D 1N4148-S 03002	03002 SMD DIODE	13	D6-12, D14, D16, D23-26	
DBAT54S	03199 SMD SCH. DIODE A-K T	3	D1-2, D4	
DHSMP3814	03202 SMD DIODE	5	D3, D15, D17-19	
DHSMS2802 03207	03207 SMD DIODE	5	D5, D13, D20-22	
DL KA-3528SGC 03057	03057 GREEN SMD LED DIODE	7	DL1-7	
DL LEDG3 03053	03053 GREEN LED DIODE 3mm	1	DL8	
DL LEDR3 03058	03058 RED LED DIODE 3mm	1	DL9	
DV BB133 03220	03220 SMD VARICAP DIODE	8	DV1-8	
DZ 5V1-S 03128	03128 SMD ZENER DIODE	5	DZ1-5	
FUSE 2A-PCB 7543	7543 PORTA FUS. + FUSE 5x2	1	F1	
IC 7812 04321	04321 VOLTAGE REGULATOR	1	IC6	
IC 7818	04321 VOLTAGE REGULATOR	1	IC3	
IC 7824 04331	04331 VOLTAGE REGULATOR	1	IC4	
IC 78L05-S 04301A	04301A SMD VOLTAGE REG.	1	IC5	
IC 78M08 04303B	04303B SMD VOLTAGE REG.	1	IC14	
IC 78M12 4307B	04307B SMD VOLTAGE REG.	3	IC10, IC16, IC22	
IC CD4053BC-S 04710A	04710A SMD INTEG CIRCUIT	1	IC11	
IC EL2090CM-S	04640A SMD INTEG CIRCUIT	1	IC18	
IC EL2245CS-S 04822	04822 SMD INTEG CIRCUIT	1	IC7	
IC HFA3101	04598 INTEG CIRCUIT	1	IC8	
IC LM1881M	04645A INTEG CIRCUIT	1	IC15	
IC LM324M-S 04658A	04658A SMD INTEG CIRCUIT	2	IC23-24	
IC LM358M-S 04660	04660 SMD INTEG CIRCUIT	1	IC20	
IC LM833-S 04643A	04643A SMD INTEG CIRCUIT	3	IC13, IC19, IC21	
IC MAR4 04368	04368 SMD INTEG CIRCUIT	1	IC17	
IC MAV11-S 04373	04373 INTEG CIRCUIT	1	IC9	
IC MC14066BD-S 4708B	4708B SMD INTEG CIRCUIT	1	IC12	
IC MC145170-S 04683A	04683A SMD INTEG CIRCUIT	2	IC1-2	
IND 10uH-5CCD 04971	04971 INDUCTOR	1	MF1	
IND 180nH-S 05093	05093 INDUCTOR	10	L2-5, L19, L23-24, L33-35	
IND 22uH-S 5023D	5023D INDUCTOR	5	L1, L6, L18, L26-27	
IND 2uH-S 05020A	05020A INDUCTOR	8	L9, L14, L21-22, L25, L28, L31-32	
IND 30uH-5CCD 04972	04972 INDUCTOR	8	MF2-9	
IND 330nH-5CCE	04974 INDUCTOR	3	L8, L10, L29	
IND CBD8 05072	05072 INDUCTOR	6	L12, L15-17, L20, L30	
IND MS85 10uH-S	04948 INDUCTOR 2,7A	3	L7, L11, L13	
JBNC-90G-PCB 2034	02034 PCB CONNECTOR	1	J22	

Part Name/Number	Description	Qty.	Comps.	Page 3/5
JCON HD515V/05-3PVE	02893 + 02894 PAN. PCB CONN	2	J1-2	
JFC-10P 02697-02699	02697+02699 PCB CON. POL	1	J7	
JFC-20P 02868-02867	02868+02867 PCB CON. POL	1	J8	
JNC3FD-H 02862	02862 XLR-90G-PCB SOC. FEM.	1	J23	
JSMB-PCB 02516	02516 PCB CONNECTOR	10	J5-6, J12-19	
JTESTP1.3mm 07913	07913 TEST POINT	7	J3-4, J9-11, J20-21	
JU JUMP2 02739-02742	02739+02742 MASCHIO PAN2	7	JP4, JP8, JP14-16, JP22-23	
JU JUMP3 02707-02742	02707+02742 MASCHIO PAN3	16	JP1-3, JP5-7, JP9-13, JP17-21	
MX RMS-11X	05332 MIXER	1	MX1	
OSC HCD310 05187	05187 INTEGRATED OSCIL.	1	OSC2	
OSC NVT535 05168	05168 TCXO	1	OSC1	
PN0745AR4 SCH0136AR0	SCH0136AR0 VCO IV & V	1	VCO1	
R 0R0-S 00001	00001 RES 1/4W 5% SMD 1206	2	R145, R184	
R 100K-1%-S 00065B	00065B RES 1/4W 1% SMD 1206	5	R127, R135, R147-149	
R 100K-S 00065A	00065A RES 1/4W 5% SMD 1206	11	R15, R20, R69, R138-139, R150, R256-257, R284, R285, R313	
R 100R-1W-S	00383 RES 1W 5% SMD 2512	2	R38, R291	
R 100R-S 00029A	00029A RES 1/4W 5% SMD 1206	23	R4, R10, R23, R53, R61, R78, R98, R122, R131, R140, R151, R174-177, R224, R226, R229, R232, R233-235, R273	
R 10K-S 00053A	00053A RES 1/4W 5% SMD 1206	38	R7, R13, R24-25, R31, R34, R40, R76-77, R96-97, R114-115, R121, R166-167, R170-171, R178-180, R199-201, R237, R239, R258, R260-262, R269-270, R277-278, R280, R286, R297, R299	
R 10R-S 00017A	00017A RES 1/4W 5% SMD 1206	5	R30, R56, R189-190, R222	
R 1206 N.M.	N.M. RES 1/4W 5% SMD 1206	10	R3, R9, R27, R63, R118, R125, R144, R146, R185, R186	
R 120R-S 00030A	00030A RES 1/4W 5% SMD 1206	4	R129, R264-266	
R 150K-S 00067A	00067A RES 1/4W 5% SMD 1206	1	R231	
R 150R-S 00031A	00031A RES 1/4W 5% SMD 1206	2	R102, R104	
R 15K-S 00055A	00055A RES 1/4W 5% SMD 1206	2	R183, R187	
R 180R-S 00032A	00032A RES 1/4W 5% SMD 1206	4	R14, R19, R49, R64	
R 18K-S 00056B	00056B RES 1/4W 5% SMD 1206	4	R221, R230, R282, R287	
R 1K0-1%-S 00041B	00041B RES 1/4W 1% SMD 1206	16	R154, R157, R160, R163, R192, R194, R196, R198, R211, R213, R215, R217, R241, R244, R247, R250	
R 1K0-S 00041A	00041A RES 1/4W 5% SMD 1206	17	R1, R5, R11, R28, R52, R60, R83, R88, R92, R95, R124, R165, R181, R289, R293, R301, R315	
R 1K2-1%-S 00042A	00042A RES 1/4W 1% SMD 1206	4	R82, R164, R219-220	
R 1K5-S 00043A	00043A RES 1/4W 5% SMD 1206	5	R33, R45, R80, R203, R207	
R 1M-S 00077A	00077A RES 1/4W 5% SMD 1206	4	R6, R12, R137, R255	
R 220K-S 00069A	00069A RES 1/4W 5% SMD 1206	1	R93	
R 220R-S 00033A	00033A RES 1/4W 5% SMD 1206	5	R43-44, R46, R62, R105	
R 22K-S 00057A	00057A RES 1/4W 5% SMD 1206	4	R41, R89, R202, R206	
R 22R-S 00021A	00021A RES 1/4W 5% SMD 1206	5	R67, R134, R238, R240, R254	
R 270R-S 00034A	00034A RES 1/4W 5% SMD 1206	2	R106, R133	

Part Name/Number	Description	Qty.	Comps.	Page 4/5
R 27K-S 00058A	00058A RES 1/4W 5% SMD 1206	2	R26,R32	
R 27R-S 00022A	00022A RES 1/4W 5% SMD 1206	2	R47,R55	
R 2K2-S 00045A	00045A RES 1/4W 5% SMD 1206	10	R68, R72, R91, R110-111, R141, R253, R267-268, R271	
R 2K7-S 00046A	00046A RES 1/4W 5% SMD 1206	2	R168, R205	
R 330R-S 00035B	00035B RES 1/4W 5% SMD 1206	5	R17, R22, R36, R123, R182	
R 33R-S 00023A	00023A RES 1/4W 5% SMD 1206	2	R58-59	
R 390R-S 00036A	00036A RES 1/4W 5% SMD 1206	2	R37, R81	
R 39K-S 00060A	00060A RES 1/4W 5% SMD 1206	1	R90	
R 39R-S 00024A	00024A RES 1/4W 5% SMD 1206	4	R103, R274-275, R295	
R 3K3-S 00047A	00047A RES 1/4W 5% SMD 1206	1	R290	
R 3K9-S 00048A	00048A RES 1/4W SMD 1206	2	R50, R227	
R 470K-S 00073A	00073A RES 1/4W 5% SMD 1206	2	R51, R283	
R 470R-S 00037A	00037A RES 1/4W 5% SMD 1206	3	R57, R169, R173	
R 47K-S 00061A	00061A RES 1/4W 5% SMD 1206	7	R16, R21, R99-100, R128, R276, R279	
R 47R-S 00025A	00025A RES 1/4W 5% SMD 1206	13	R2, R8, R18, R35, R48, R65, R75, R94, R172, R204, R223, R228, R294	
R 4K7-S 00049A	00049A RES 1/4W 5% SMD 1206	6	R112-113, R117, R136, R281, R288	
R 56K-S	00062A RES 1/4W 5% SMD 1206	4	R71, R73, R108, R120	
R 56R-S 00026A	00026A RES 1/4W 5% SMD 1206	5	R54, R101, R130, R188, R208	
R 5K6-S 00050A	00050A RES 1/4W 5% SMD 1206	8	R191, R193, R195, R197, R212, R214, R216, R218	
R 680K-S	00075A RES 1/4W 5% SMD 1206	1	R126	
R 680R-S 00039A	00039A RES 1/4W 5% SMD 1206	2	R39, R107	
R 68K-S 00063A	00063A RES 1/4W 5% SMD 1206	2	R74, R209	
R 68R-S 00027A	00027A RES 1/4W 5% SMD 1206	3	R225, R272, R292	
R 75R-1%-S 00221B	00221B RES 1/4W 1% SMD 1206	2	R85, R119	
R 820R-S 00040A	00040A RES 1/4W 5% SMD 1206	1	R132	
R 82K-S 00064A	00064A RES 1/4W 5% SMD 1206	1	R210	
R 82R-S 00028A	00028A RES 1/4W 5% SMD 1206	1	R236	
RL TQ2-SA-12 07569A	07569A RELE	1	RLY1	
RV 100K-S-H/S 00802	00802 SMD VARIABLE RES.	2	R259, R263	
RV 100R-S-H/S 00796	00796 SMD VARIABLE RES.	2	R29, R66	
RV 10K-M-H 00777	00777 VARIABLE RESISTOR	6	R300, R302, R312, R314, R316-317	
RV 10K-S-H/S 00793	00793 SMD VARIABLE RES.	17	R70, R84, R86-87, R109, R116, R142-143, R152, R155, R158, R161, R243, R246, R249, R252, R296	
RV 1K-S-H/S 00792	00792 SMD VARIABLE RES.	10	R42, R79, R153, R156, R159, R162, R242, R245, R248, R251	
RV 200R-M-H 00775	00775 VARIABLE RESISTOR	4	R298, R303, R306, R309	
RV 500R-M-H 00790	00790 VARIABLE RESISTOR	6	R304-305, R307-308, R310-311	
SAWB588-PAL/BG	OPTION_CODE SAW FILTER	1	SAW1	
SW KW002660	SWITCH2 VIE 2 POSIZION	3	SW1-3	
TR.BC848 03457	03457 NPN SMD TRANSISTOR	28	TR1-8, TR12, TR14-15, TR17-18, TR20, TR23, TR25, TR27, TR29, TR31, TR33, TR36, TR38, TR40, TR42, TR46-49	
TR.BC856 03455	03455 PNP SMD TRANSISTOR	12	TR16, TR19, TR21-22, TR26, TR28, TR30, TR32,	

Part Name/Number	Description	Qty.	Comps.	Page 5/5
TR BFG35 03990	03990 NPN SMD TRANSISTOR	6	TR37, TR39, TR41, TR43	
TR BFR93A 03447	03447 NPN SMD TRANSISTOR	1	TR11, TR13, TR34-35, TR44-45	
TR PMBFJ310 04105A	04105A NFET SMD TRANS.	2	TR24	
TR ASF CHOKE 05034	05034 WIDEBAND TRANS.	3	TR9-10	
			BL1-3	

CALIBRATION POINTS

- Adjustments points description

COMPONENT	DESCRIPTION
C23	Video carrier oscillator tuning capacitor
C26	Audio carrier oscillator tuning capacitor
DL1	Locked video IF PLL indication LED
DL2	Locked audio IF PLL indication LED
DL4	Board power indication LED
DL3	Modulation section power indication LED
DL5	Locked local oscillator PLL indication LED
DL6	Conversion section power indication LED
DL7	Baseband section power supply indication LED
DL8	Enabled linearity pre-corrector LED
DL9	3dB Power decrease indication LED
F1	Board power supply fuse
J22	75Ω BNC video input connector
J3	Testpoint for measure of video carrier PLL lock voltage
J4	Testpoint for measure of audio carrier PLL lock voltage
J6	SMB 50Ω IF connection output connector
J5	SMB PLL External reference input connector
J8	Display board-20 pin connector
J10	Testpoint fro processed audio output before modulation
J9	Testpoint for channel synthesis VCO test
J11	Testpoint for regenerated synchronism level measurement
J7	RF Stage 10 pin connector
J13	SMB 75Ω Processed video output signal monitor connector

J14	SMB IF output signal monitor connector before the mixer
J12	SMB 50Ω RF output signal connector
J15	SMB 50Ω Local oscillator output monitor connector
J16	SMB 50Ω IF input connector
JP17	Expansion / Compression function selection cell n. 1
J20-21	AGC Voltage measurement testpoint
J23	XLR 600Ω Balanced audio input connector
JP1	Jumper for audio carrier activation
JP3	Jumper for frequency reference selection
JP4-JP20	Jumpers for video processor exclusion
JP6	Jumper for white limitation exclusion
JP7	Jumper for synchronism regeneration insertion
JP8	Jumper for audio limitation insertion
JP9-JP10	Jumpers for 15kHz low-pass filter exclusion
JP13-JP18	Jumpers for group delay pre-correction stage exclusion
JP14-JP15	Jumpers for audio emphasis time-constant definition
JP19	Jumper for Forward power reading source selection
JP11	Jumper for IF signal monitoring before the mixer
JP16	Jumper for audio input impedance selection
L7	Video carrier oscillator tuning coil
L9	Audio carrier oscillator tuning coil
MF1	White limitation circuit chrome-trap tuning coil
MF2...MF9	Video group delay pre-correction cells tuning coil
OSC1	Internal reference frequency fine adjust
R29	Video sub-carrier level regulation trimmer
R42	Video amplitude modulation depth regulation trimmer
R66	IF Output level regulation trimmer

R70	Synchronism limitation circuit intervention setting trimmer
R79	Audio deviation regulation trimmer
R84	Regenerated synchronism level regulation trimmer
R86	Video synchronism level indication regulation trimmer
R87	Audio deviation level indication regulation trimmer
R109	White limitation circuit intervention setting trimmer
R116	Audio deviation limitation circuit symmetry trimmer
R142-143	Automatic / Manual input AGC level
R263	Reflected power indication regulation trimmer
R259	Forward power indication regulation trimmer
R152	Video pre-corrector cell 8 passing band regulation trimmer
R153	Video pre-corrector cell 8 group delay regulation trimmer
R155	Video pre-corrector cell 7 passing band regulation trimmer
R156	Video pre-corrector cell 7 group delay regulation trimmer
R158	Video pre-corrector cell 6 passing band regulation trimmer
R159	Video pre-corrector cell 6 group delay regulation trimmer
R161	Video pre-corrector cell 5 passing band regulation trimmer
R162	Video pre-corrector cell 5 group delay regulation trimmer
R242	Video pre-corrector cell 1 passing band regulation trimmer
R243	Video pre-corrector cell 1 group delay regulation trimmer
R245	Video pre-corrector cell 2 passing band regulation trimmer
R246	Video pre-corrector cell 2 group delay regulation trimmer
R248	Video pre-corrector cell 3 passing band regulation trimmer
R249	Video pre-corrector cell 3 group delay regulation trimmer
R251	Video pre-corrector cell 4 passing band regulation trimmer
R252	Video pre-corrector cell 4 group delay regulation trimmer
R298	Video input level regulation trimmer

R300	Audio sub-carrier level regulation trimmer
R302	Audio input level regulation trimmer
R303-304-305	Knee and inclination phase of the cell n. 1
R306-307-308	Knee and inclination phase of the cell n. 2
R309-310-311	Knee and inclination phase of the cell n. 3
R312	IF Gain regulation trimmer in normal mode
R314	IF Gain regulation trimmer in automatic mode
R316	IF Gain regulation trimmer in automatic mode with ext. amplifier
R317	OCCO Fine tuning Freq. adj.
SAW1	Vestigial SAW filter, depending on the standard
SW1	Linearity pre-correction insertion switch
SW2-3	IF Gain control mode selection switch
VCO1	PLL controlled local oscillator board insertion slot

VIDEO BASE BAND SECTION CHECK

Video Restore Processor: set JP5-JP20 on PCPS_ON and JP13-JP18 on GD_OFF, connect a video source with VITS to J22 and a video parameter measure equipment on J13 (video base band output) and check the functionality of the included sections.

- ❑ Check that while JP7 on SYNC_REST_ON the level of the regenerated synchronism can be adjust by means of R84 (this level can be measured on J11).
- ❑ Check that while JP6 is on WHITE_CLIP_ON the white limitation circuit, which intervention level can be adjust by means of R109 (the trap on the chrome carrier can be adjusted by acting on MF1).
- ❑ Check that the synchronism limitation circuit, which intervention level can be adjusted by means of R70.
- ❑ Adjust R86 to obtain the desired deviation of the SYNC_METER instrument.

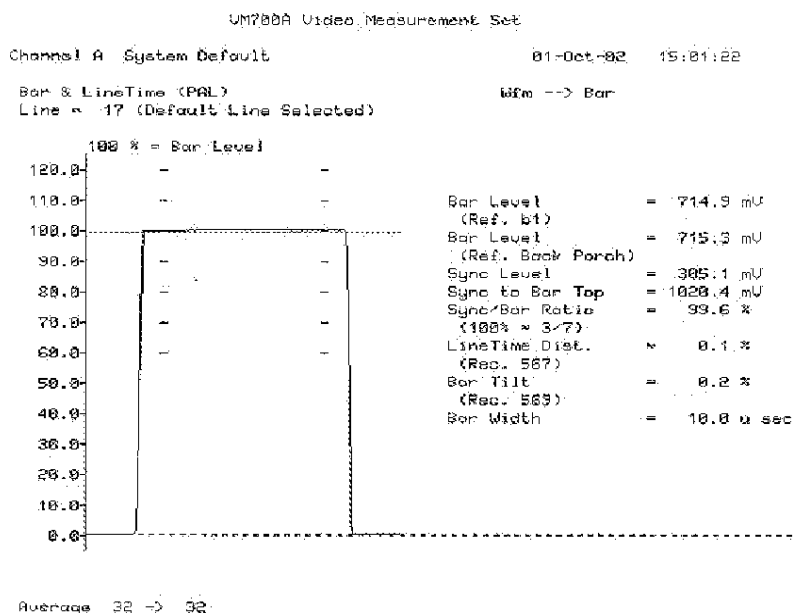

Video Group Delay Processor: set JP5-JP20 on PCPS_ON and JP13-JP18 on GD_ON, connect a video source with VITS to J22 and a video parameter measure equipment on J13 (video base band output) and check the functionality of the included sections.

- ❑ Calibrate the group delay pre-correction (R153, R156, R159, R162, R242, R245, R248, R251) and passing band (R152, R155, R158, R161, R243, R246, R249, R252) cells so to obtain the frequency

response required by the system standard. If needed perform a fine tuning of the tuning frequency of the cells by acting on MF2...MF9.

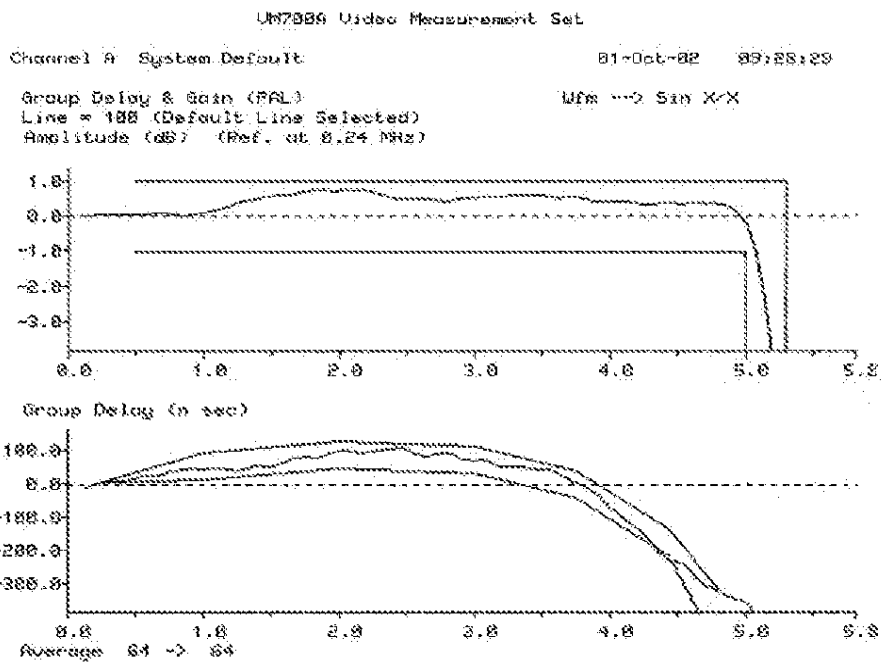

AUDIO BASE BAND SECTION VERIFICATION

Audio Processor: set JP16 on 600_OHM, JP14-JP15 on 50_us, JP9-JP10 on LPF_ON and JP8 on AUDIO_CLIP, connect a 600Ω balanced audio source on J23 and an audio parameter measure equipment on J10 (audio base band output) and check the functionality of the included sections.

- Calibrate R116 to achieve the symmetry of the deviation limitation circuit.
- R79 will be used to obtain the desired deviation on the FM signal of the audio sub-carrier (see Audio-Video Modulation section).
- Calibrate R87 to achieve the desired deviation of the VU_METER instrument.

INTERMEDIATE FREQUENCY SECTION CHECK

IF Carriers (Video & Audio): set JP1 on SC_ON, select the standard of the included section.

- Calibrate C23-L7 to a voltage of 2,5V on J3 with DL1 on (PLL locked).
- Calibrate C26-L9 to a voltage of 2,5V on J4 with DL2 on (PLL locked).

AV Modulator: set JP5-JP20 on PCPS_OFF, SAW1 with the correct filter, connect a video source with VITS to J22, an audio source to J23 and an audio-video demodulator on J6 (IF modulated output) and check the functionality of the included sections.

- Adjust R30 to the maximum excursion (video carrier at maximum level).
- Adjust R300 to obtain a -10dB level of the audio sub-carrier compared to the video sub-carrier.
- Adjust R42 to the correct modulation depth (*bar/sync* ratio = 7/3).
- Adjust R66 to obtain an IF level of about -15dBm.

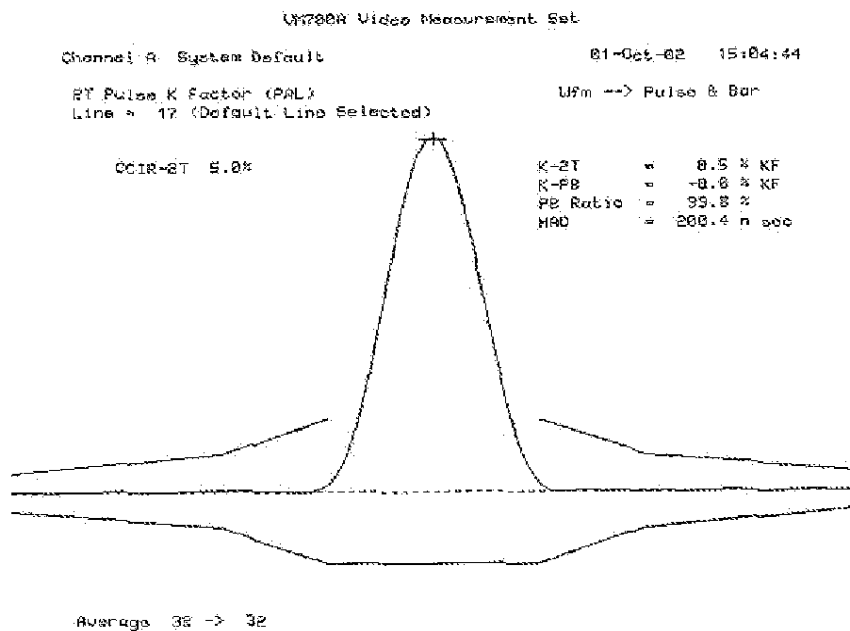

UM700A Video Measurement Set

Channel A System Default

01-Oct-88 19:07:51

DQ DP (PAL)

Wfm --> Composite

Line = 330 (Default Line Selected)

Differential Gain (%) min = -0.77 max = 0.87 pk-pk = 0.84

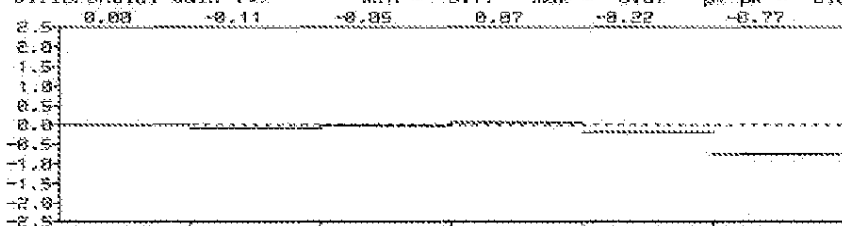

Differential Phase (deg) min = -0.14 max = 0.55 pk-pk = 0.69

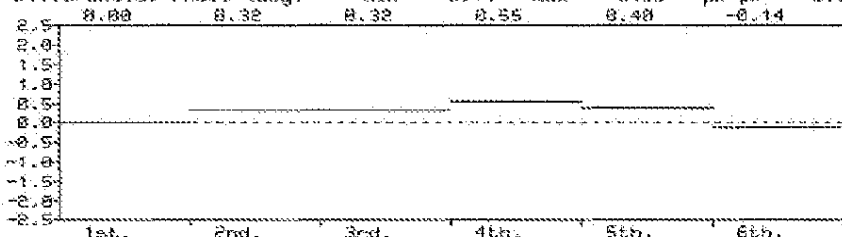

Average 64 -> 64

UM700A Video Measurement Set

Channel A System Default

01-Oct-88 09:28:29

Group Delay & Gain (PAL)

Wfm --> Sx1 X/Y

Line = 100 (Default Line Selected)

Amplitude (dB) (Ref. at 0.24 MHz)

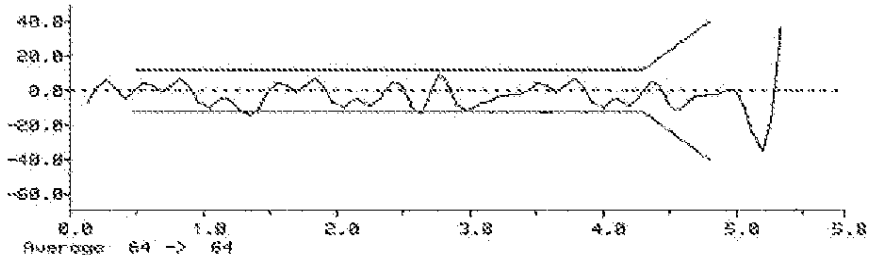
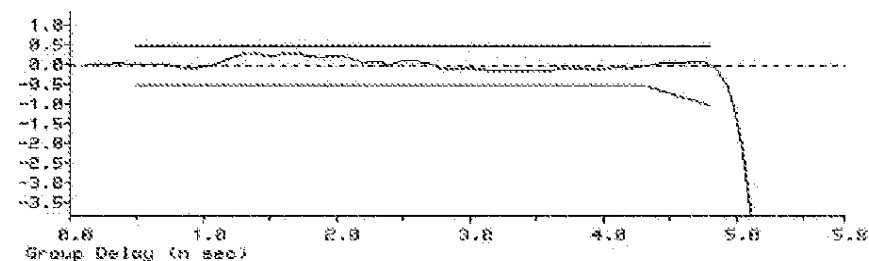

Average 64 -> 64

UM7000 Video Measurement Set

Channel A System Default

01-Oct-92 15:07:51

Noise Spectrum (PWL) Wife 0% Pedestal
Line = 22 (Default Line Selected)
Amplitude (0 dB = 200 mV p-p) Noise Level = -67.3 dB rms
Band width 200kHz to 5.0MHz

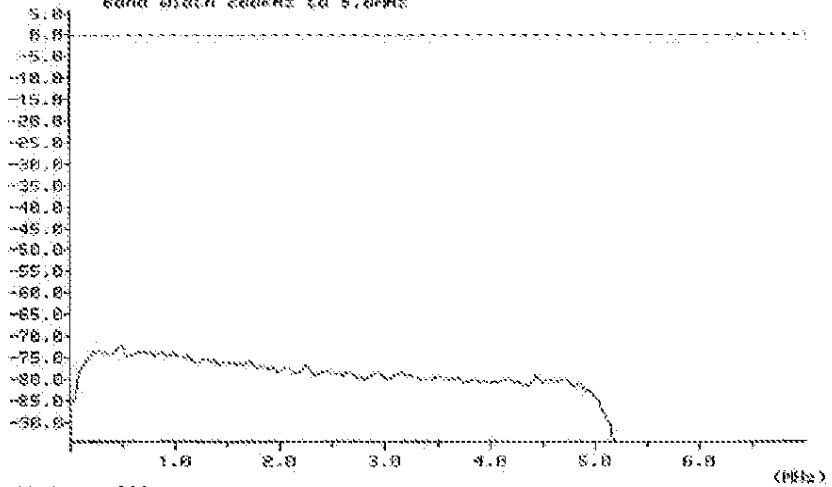

UP-CONVERTER CHECK

Local Oscillator: set **VCO1** with the board for the desired band, select the desired channel from the display board (see relevant documentation) and check the functionality of the included sections.

- Calibrate the local oscillator (see relevant documentation) to the desired channel with **DL5** on (PLL locked) and check the current tuning on the display board (indication of the VCO instrument at half-scale) by connecting a spectrum analyser on **J15** (OL monitor).

Linearity pre-corrector and Gain control: set **JP11** on **IF_MONITOR_ON**, connect a sweeper to **J16** (IF Input), a spectrum analyser on **J14** (IF Monitor) and check the functionality of the included sections.

- Check the response curve of the section and the changes in gain by acting on **R312** with **SW2** on manual control and checking the control voltage on **J20**.
- Check that when the linearity pre-corrector is enabled (**SW1** on ON) the response curve of the system is not negatively affected.
- Adjust **R142** with **JP12** on “ALC ON” to have 0dBm on the test port **J19**.
- The precorrection will be obtained adjusting trimmers from **R303** to **R311**.
- Set **JP17** and **JP21** to have the desired type of precorrection mode for amplitude and phase respectively.

UP-Converter: set **JP11** on **IF_MONITOR_OFF**, connect a sweeper to **J16** (IF Input), a spectrum analyser on **J12** (RF Output) and check the functionality of the included sections).

- Check the presence of the side bands and the local oscillator in the position of the desired channel.

Power readings: set **JP19** on **FWD_READING**, **R263** allows to calibrate the reading of the Reflected power and **R259** the reading of Forward power (these can only be calibrated if the apparatus is complete with final stage).

GENERAL SECTION CALIBRATION

Reference oscillator: set **JP3** on **INT_REF** and adjust **R317** **FINE_ADJ** to tune the reference frequency if needed (only with OCXO included on the mother board).

EXTERNAL AGC OPERATION

- With **SW2** on “AUTO” the exciter will be in Automatic Gain Control mode.
- Selecting **SW3** on “INT” an AGC on the internal power amplifier will be performed acting on **R314** (optionally in this mode an external voltage connected on **J18**, 0...5V, can be used to fine adjust, $\pm 10\%$, the power remotely).
- Selecting **SW3** on “EXT” a fine ALC (Automatic Level Control), $\pm 10\%$, can be performed on an external power amplifier which the forward directional coupler is fed to **J17** (optional).

TECHNICAL CHARACTERISTICS

- Analog readings

Forward power	Indication on analog instrument and numerical with alarm
Reflected power	Indication on analog instrument and numerical with alarm
Synchronism level	Indication on analog instrument
Audio deviation	Indication on analog instrument
Heat sink temperature	Indication on analog instrument and numerical with alarm
Channel VCO tuning	Indication on analog instrument with alarm
Final stage working voltage	Indication on analog instrument and numerical
Current absorbed by the final stage	Indication on analog instrument and numerical

- Digital controls

IF PLL Lock status	Indication on audio and video sub-carriers and channel carrier
Alarm status	Alarm indication on one of the readings
ON - OFF	Remote control of powered apparatus

- Programming

IF PLL	Programming of the oscillators PLL depending on the standard
Channel PLL	Programming of the oscillator PLL depending on the channel

Component layout SCH0123AR1

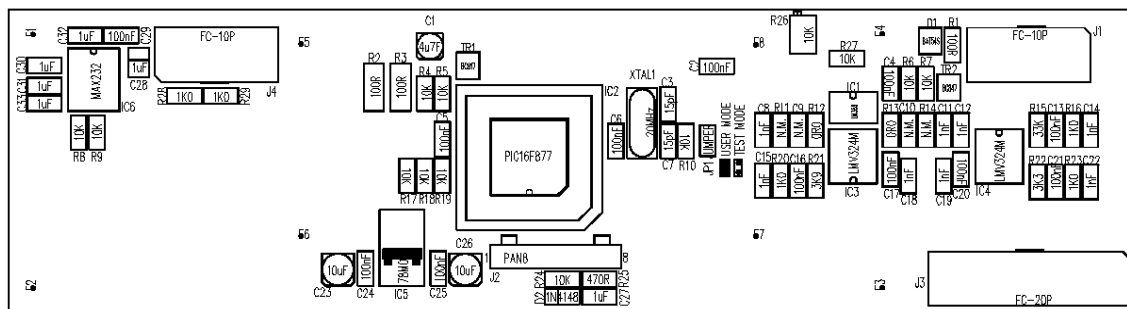
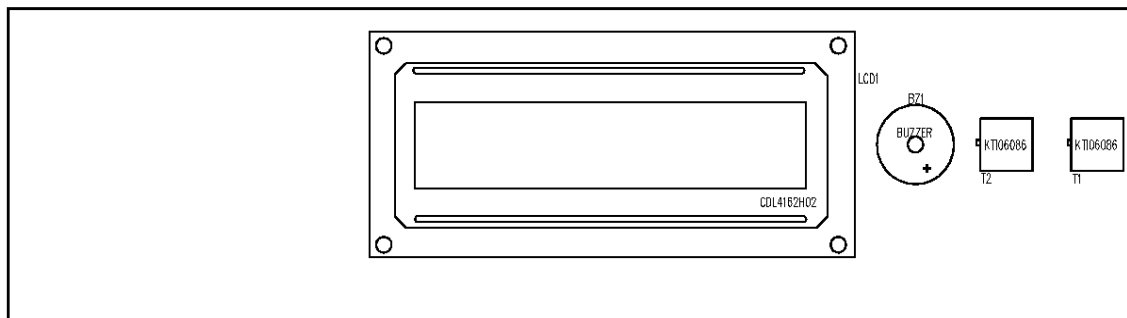

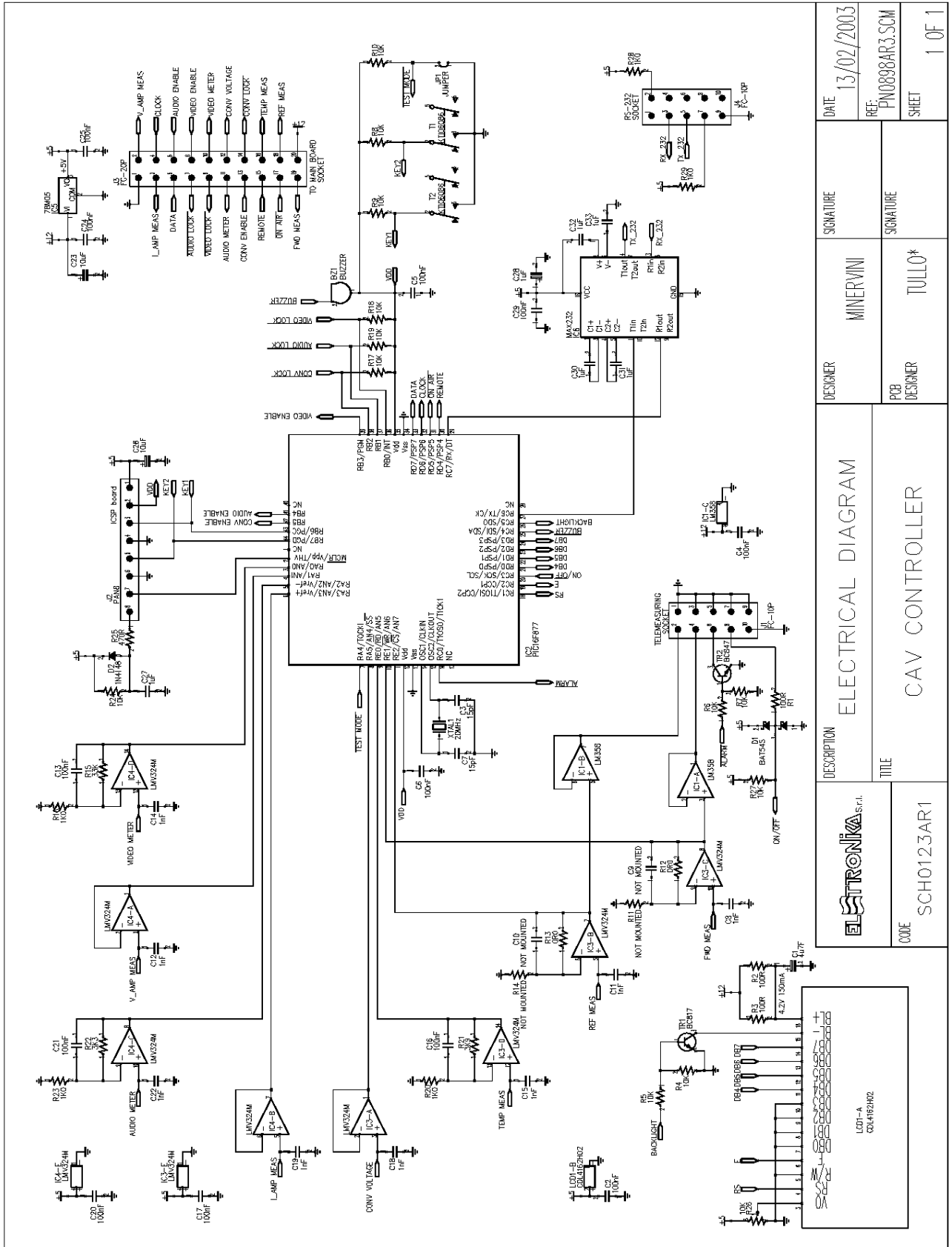

ELSTRONIKA S.r.l.	DESCRIPTION ELECTRICAL DIAGRAM		DESIGNER MINERVINI	SIGNATURE 	DATE 13/02/2003
	CODE SCH0123AR1	TITLE CAV CONTROLLER		POB DESIGNER TULLO*	SIGNATURE
			REF PIN0898AR3.SCM	SHEET 1 OF 1	

COMPONENT LIST SCH0123ARI

Part Name/Number	Description	Qty.	Comps.
BZ AI-155 03705	03705 5VDC BUZZER	1	BZ1
CC 100nF-S 01065C	01065C Y5V 1206 COND	12	C2, C4-6, C13, C16-17, C20-21, C24-25, C29
CC 1206 NOT MOUNTED	NOT MOUNTED SMD 1206 COND	2	C9-10
CC 15pF-S 01088	01088 SMD 1206 COND	2	C3, C7
CC 1uF100V-S 01760A	01760A Y5V 1206 COND	5	C27, C30-33
CC 1nF-S 01096	01096 SMD 1206 COND	8	C8, C11-12, C14-15, C18-19, C22
CE 10uF35V-S 01778A	01778A ELETTR SMD COND	2	C23, C26
CE 1uF35V-S 01613A	01613A TANTALIUM ELETTR SMD CO	1	C28
CE 4u7F35V-S 01774A	01774A ELETTR SMD COND	1	C1
D 1N4148-S 03002	03002 SMD DIODE	1	D2
D BAT54S	03199 SMD SCHOTTKY DIODE A-K T	1	D1
DIS CDL4162H02	03073 DISPLAY	1	LCD1
IC 78M05 04301B	04301B SMD VOLTAGE REGULATOR	1	IC5
IC LM358M-S 04660	04660 SMD INTEG CIRCUIT	1	IC1
IC LMV324M-S 04658B	04658B SMD INTEG CIRCUIT	2	IC3-4
IC MAX232-S 04804B	04804B SMD INTEG CIRCUIT	1	IC6
IC PIC16F877 4869	04869+07509B INTEG CIRCUIT	1	IC2
J FC-10P 02697-02699	02697+02699 PCB CONNECTOR POL	2	J1, J4
J FC-20P 02868-02867	02868+02867 PCB CONNECTOR POL	1	J3
J PAN8 02716	02716 PCB CONNECTOR	1	J2
JU JUMP2 02739-02742	02739+02742 MASCHIO PAN2	1	JP1
R 0R0-S 00001	00001 RES 1/4W 5% SMD 1206	2	R12-13
R 100R-1W-S	00383 RES 1W 5% SMD 2512	2	R2-3
R 100R-S 00029A	00029A RES 1/4W 5% SMD 1206	1	R1
R 10K-S 00053A	00053A RES 1/4W 5% SMD 1206	12	R4-10, R17-19, R24, R27
R 1206 NOT MOUNTED	NOT MOUNTED RES 1/4W 5% SMD 12	3	R11, R14, R29
R 1K0-1%-S 00041B	00041B RES 1/4W 1% SMD 1206	2	R16, R20
R 1K0-S 00041A	00041A RES 1/4W 5% SMD 1206	2	R23, R28
R 33K-S 00059A	00059A RES 1/4W 5% SMD 1206	1	R15
R 3K3-S 00047A	00047A RES 1/4W 5% SMD 1206	1	R22
R 3K9-1%-S 00048B	00048B RES 1/4W 1% SMD 1206	1	R21
R 470R-S 00037A	00037A RES 1/4W 5% SMD 1206	1	R25
RV 10K-3266X 00807	00807 VARIABLE RESISTOR	1	R26
T 06086N 7630 7632	7630 7632 KTI06086 PULSANTE 2	2	T1-2
TR BC817 03454	03454 NPN SMD TRANSISTOR	1	TR1
TR BC847 03456	03456 NPN SMD TRANSISTOR	1	TR2
XTAL 20MHz-S	CXS00001 QUARTZ	1	XTAL1

ADJUSTMENT POINTS DESCRIPTION

COMPONENT	DESCRIPTION
JP1	Jumper for mode setting
J1	Telemeasuring connector
J2	Microprocessor in-circuit programming pan
J3	Connector for connection to mother board
J4	RS232 Connector

Calibration procedure: the board does not need any calibration, it only takes checking that it works for the concerned application.

TECHNICAL CHARACTERISTICS

Working frequency	500...900MHz
Programming	PLL with manual tuning of the oscillator
Tuning indication	Analog 0...5V + Digital for lock status
Output level	>0dBm (+7...8dBm maximum)

ADJUSTMENT POINTS DESCRIPTION

COMPONENT	DESCRIPTION
-----------	-------------

C30	Fine-tuning coupling capacitor
C31	Gross-tuning capacitor

Calibration procedure: the board has to be tuned on the desired channel by acting on the capacitors **C30** and **C31** and removing some turns from the coil if needed (it is necessary for higher channels).

Component layout SCH0136AR0

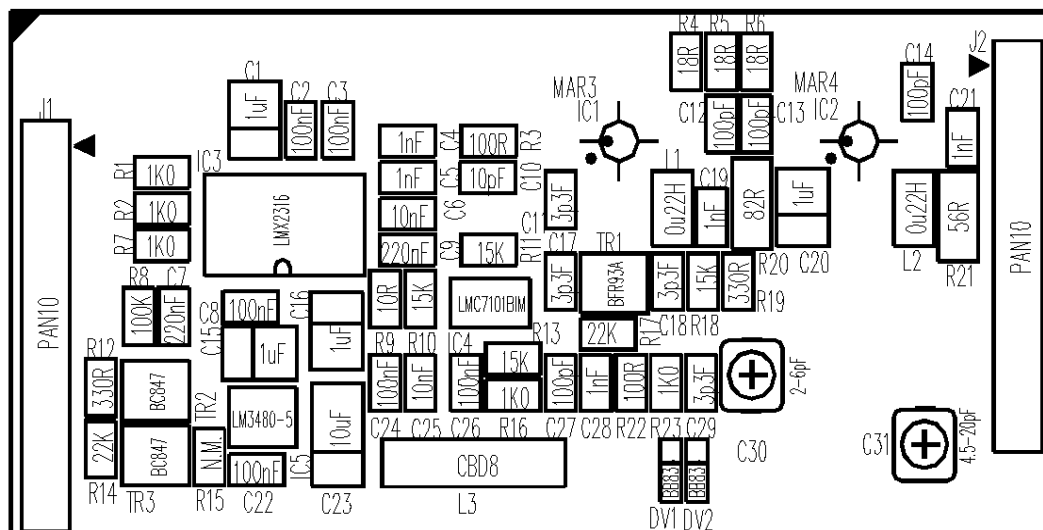

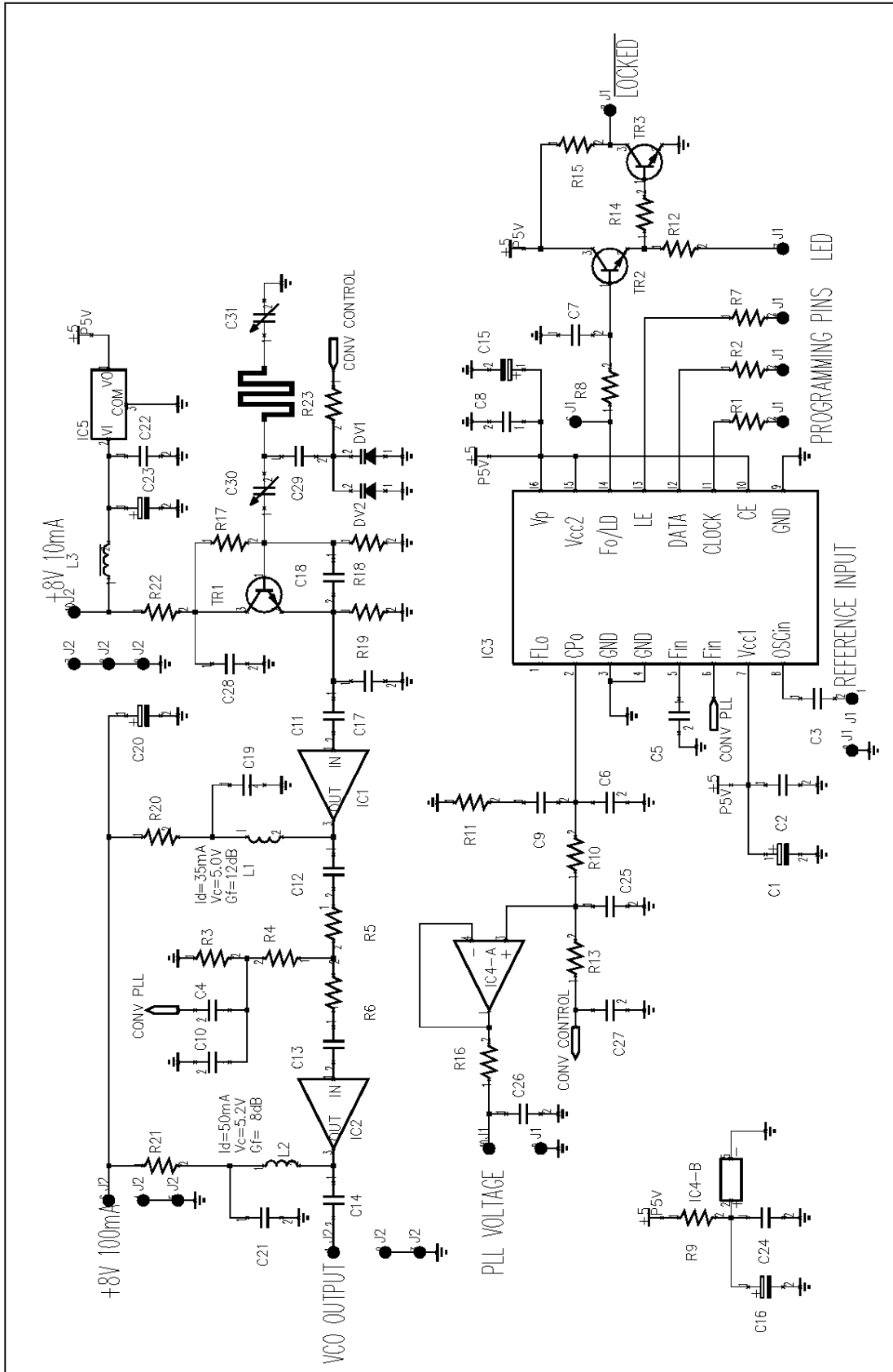

	DESCRIPTION	ELECTRICAL DIAGRAM	
	TITLE	UHF IV/V BAND LOCAL OSCILLATOR	
CODE	SCH0136AR0	DESIGNER	MINERVINI
		PCB DESIGNER	TULLO
		SIGNATURE	SIGNATURE
		DATE	01/07/2002
		REF:	PN0745AR4
		SHEET	1 OF 1

COMPONENT LIST SCH0136AR0

Part Name - Code	Description	Qty	Composition
CC 100nF-S 01065E	01065E Y5V 0805 COND	6	C2-3, C8, C22, C24, C26
CC 100pF-S 01092C	01092C SMD 0805 COND	4	C12-14, C27
CC 10nF-S 01053A	01053A SMD 0805 COND	2	C6, C25
CC 10pF-S 01086A	01086A SMD 0805 COND	1	C10
CC 1nF-S 01096A	01096A SMD 0805 COND	5	C4-5, C19, C21, C28
CC 220nF-S 01069B	01069B Y5V 0805 COND	2	C7, C9
CC 3p3F-SS	1011B SMD 0805 COND	4	C11, C17-18, C29
CE 10uF16V-S 01626A	01626A TANT. ELETTR SMD COND	1	C23
CE 1uF35V-S 01613A	01613A TANT. ELETTR SMD COND	4	C1, C15-16, C20
CV 2-6pF-S	01476 VARIABLE COND	1	C30
CV 4.5-20pF-S 01481	01481 VARIABLE COND	1	C31
DV BB833 03214	03214 SMD VARICAP DIODE	2	DV1-2
IC LM3480-5	4301C SMD VOLTAGE REGULATOR	1	IC5
IC LMC7101BIM	04638 SMD INTEG CIRCUIT	1	IC4
IC LMX2316-S	04599 SMD INTEG CIRCUIT	1	IC3
IC MAR3 04367	04367 SMD INTEG CIRCUIT	1	IC1
IC MAR4 04368	04368 SMD INTEG CIRCUIT	1	IC2
IND 0u22H-S 05090	05090 INDUCTOR	2	L1-2
IND CBD8 05072	05072 INDUCTOR	1	L3
J PAN10 2719	02719 PCB CONNECTOR	2	J1-2
R 0805 NOT MOUNTED	N. M. RES 1/4W 5% SMD 0805	1	R15
R 100K-S 00065C	00065C RES 1/4W 5% SMD 0805	1	R8
R 100R-S 00029B	00029B RES 1/4W 5% SMD 0805	2	R3, R22
R 10R-S 00017B	00017B RES 1/4W 5% SMD 0805	1	R9
R 15K-S 00055C	00055C RES 1/4W 5% SMD 0805	4	R10-11, R13, R18
R 18R-S 00020B	00020B RES 1/4W 5% SMD 0805	3	R4-6
R 1K0-S 00041C	00041C RES 1/4W 5% SMD 0805	4	R1-2, R7, R16
R 22K-S 00057C	00057C RES 1/4W 5% SMD 0805	2	R14, R17
R 270R-S 00034B	00034B RES 1/4W 5% SMD 0805	2	R19, R23
R 330R-S 00035C	00035C RES 1/4W 5% SMD 0805	1	R12
R 56R-S 00026A	00026A RES 1/4W 5% SMD 1206	1	R21
R 82R-S 00028A	00028A RES 1/4W 5% SMD 1206	1	R20
TR BC847 03456	03456 NPN SMD TRANSISTOR	2	TR2-3
TR BFR93A 03447	03447 NPN SMD TRANSISTOR	1	TR1
PN0745AR4	PRINTED CIRCUIT BOARD	1	-

TECHNICAL CHARACTERISTICS

Input impedance	50Ω
Output impedance	50Ω
Gain	About 35dB
Power supply	+24Vcc/200mA

CALIBRATION PROCEDURE

Filter tuning:

- ❑ Connect a **Network Analyser** between the input and the output of the filter.
- ❑ Configure the instrument to the desired channel (**2MHz/div – 10dB/div**).
- ❑ Send a **+24V** stabilised voltage to the module, which should has at least **200mA**.
- ❑ Calibrate the filter in order to obtain a response like the one in the picture on the right, with a gain of about **35dB**.

Component layout MTG0050AR0

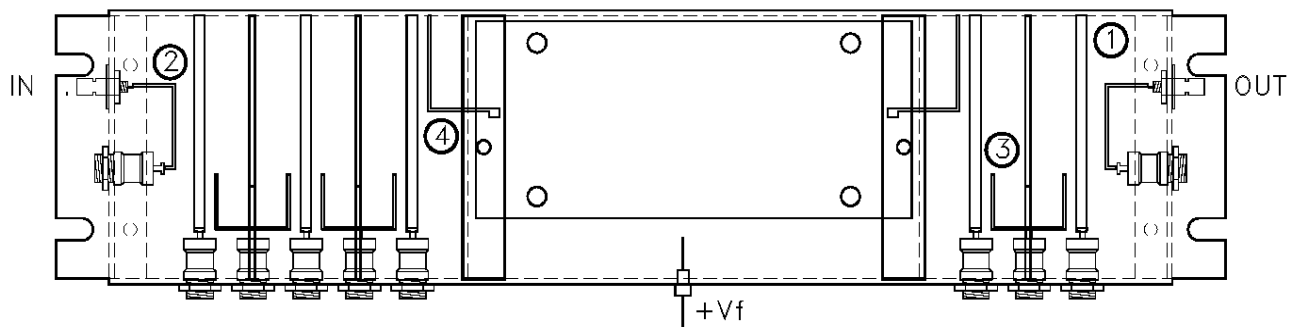

COMPONENT LIST MTG0050AR0

Part Name- Code	Description	Qty
04361	HYBRIS 35dB	1
01403	1nF PASSING C.	1
01462	COMPENS. MAV03A10	10
02514	SMB PANEL	2
07684	SILVER. WIRE Diam.1.2mm	0.2 mt
07687	SILVER. WIRE Diam.3mm	0.2 mt
05046	INDUCTANCE ON CORE	1

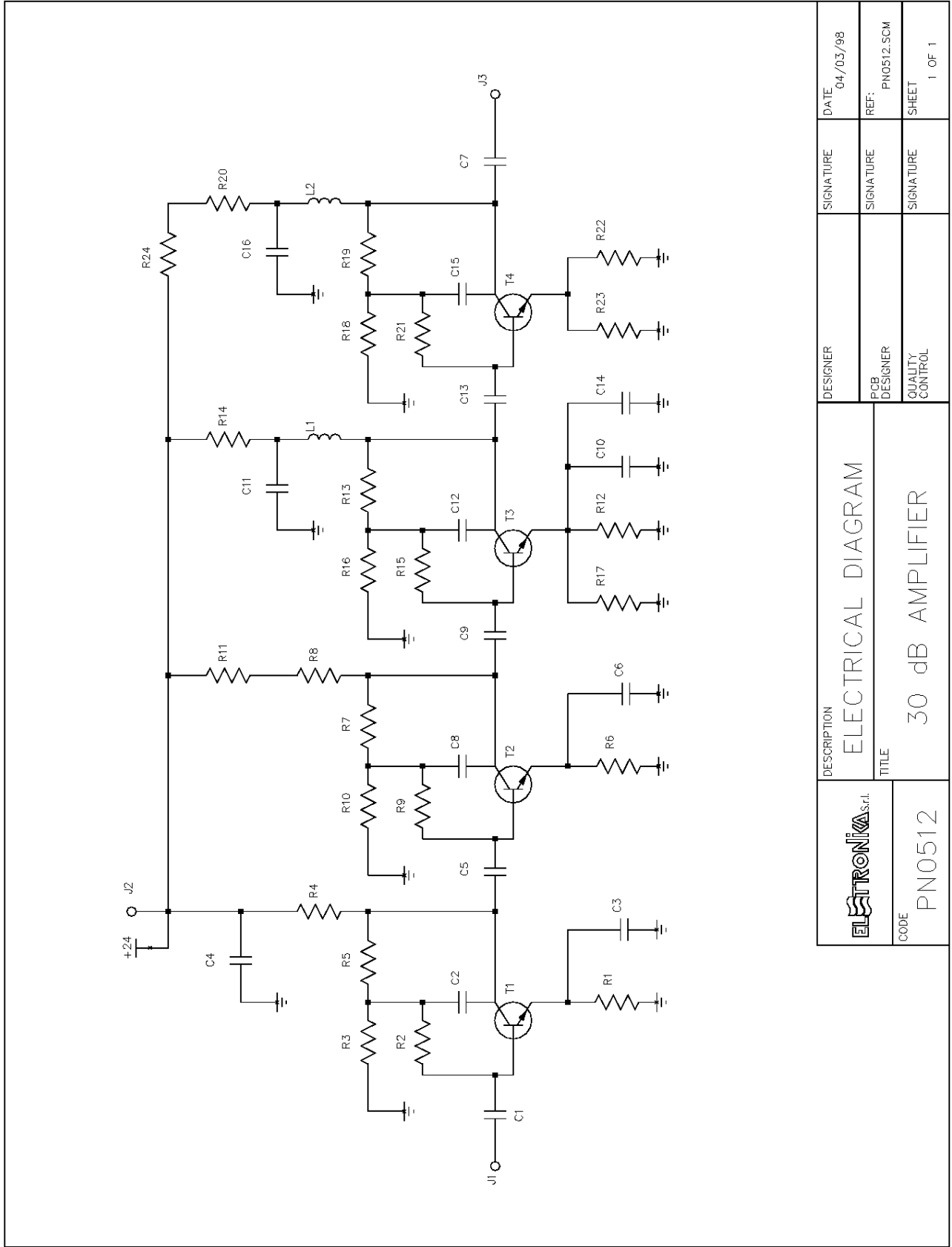

	DESCRIPTION	ELECTRICAL DIAGRAM	
	TITLE	30 dB AMPLIFIER	
CODE	PN0512	DESIGNER	SIGNATURE
		PCB DESIGNER	SIGNATURE
		QUALITY CONTROL	SIGNATURE
		DATE	04/03/98
		REF:	PN0512.SCM
		SHEET	1 OF 1

COMPONENT LIST *pn0512*

Part Name/Number	Description	Qty.	Comps.
100nH	COIL IN ARIA 6 GIRI DIAMETRO 1	2	L1-2
100R-S	1/4W 5% SMD 1206 COD.0029A	1	R2
100pF-S	63V 5% SMD NP0 COD.1092	7	C1, C7-9, C12-13, C15
10K-S	1/4W 5% SMD 1206	1	R7
10R-S	1/4W 5% SMD 1206	2	R22-23
120R-S	1/4W 5% SMD 1206	1	R9
12R-S	1/4W 5% SMD 1206	1	R1
18pF-S	63V 5% SMD NP0 COD.	1	C6
1K-S	1/4W 5% SMD 1206	3	R4, R16, R18
1nF-S	63V 5% SMD NP0 COD.1096	3	C4, C11, C16
220R-S	1/4W 5% SMD 1206	1	R11
22K-S	1/4W 5% SMD 1206	1	R5
270R-S	1/4W5% SMD 1206 COD.0034A	2	R8, R21
27pF-S	63V 5% SMD NPO	2	C2, C5
27R-S	1/4W 5% SMD 1206	1	R6
2K7-S	1/4W 5% SMD 1206	1	R10
300R-1W-S	1W 5% SMD 2512 COD.	1	R14
330R-S	1/4W 5% SMD 1206	1	R15
3K3-S	1/4W 5% SMD 1206	1	R3
4K7-S	1/4W 5% SMD 1206	1	R19
4R7-S	1/4W 5% SMD 1206	2	R12, R17
62R-1W-S	1W 5% SMD 2512 COD.	1	R20
68R-1W-S	1W 5% SMD 2512 COD.	1	R24
8.2pF-S	63V 5% SMD NP0 COD.	3	C3, C10, C14
8K2-S	1/4W 5% SMD 1206	1	R13
BFG35	NPN DA 4GHz SMD COD.3990	2	T3-4
BFR93A	NPN 35mA 300mW 6GHz COD.3447	2	T1-2

Component layout SCH0300AR0

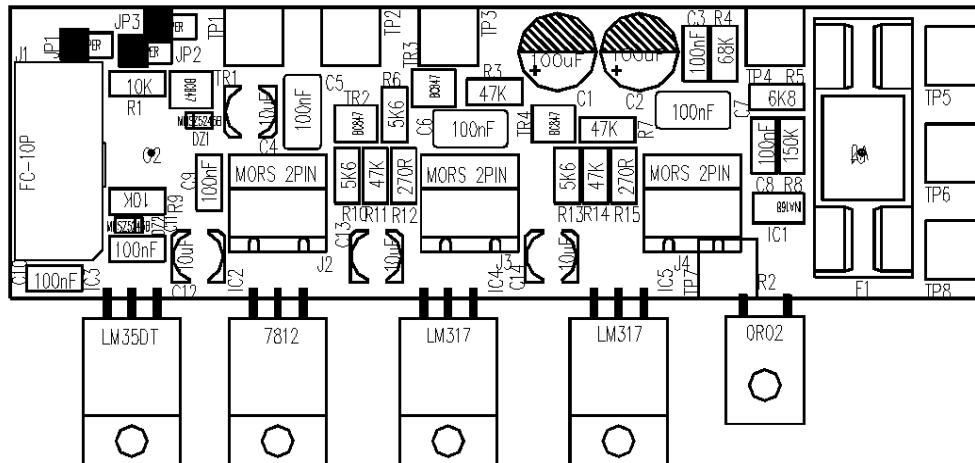

COMPONENT LIST SCH0300AR0

Part Name/Number	Description	Qty.	Comps.
CC 100nF-S 01065C	01065C Y5V 1206 COND	5	C3, C8-11
CC 100nFAVX 01065A	01065A CERAMIC COND	3	C5-7
CE 100uF50V 01795	01795 ELETT. COND.	2	C1-2
CE 10uF35V-S 01778A	01778A ELETTR SMD COND	4	C4, C12-14
DZ MMSZ5245B 03135	03135 SMD ZENER DIODE	2	DZ1-2
FUSE 2A-PCB 7543	7543 PORTA FUSIBILE + FUSE 5x2	1	F1
IC 7812 04321	04321 VOLTAGE REGULATOR	1	IC2
IC INA168	04600A SMD INTEG CIRCUIT	1	IC1
IC LM317 04340	04340 INTEG CIRCUIT	2	IC4-5
IC LM35DT 00664	00664 INTEG CIRCUIT	1	IC3
JFC-10P 02697-02699	02697+02699 PCB CONNECTOR POL	1	J1
J SCREWCONN2 02853	02853 PCB SCREW CONNECTOR	3	J2-4
JU JUMP2 02739-02742	02739+02742 MASCHIO PAN2	3	JP1-3
R 0R02	00356 RES 20W 1%	1	R2
R 10K-S 00053A	00053A RES 1/4W 5% SMD 1206	2	R1, R9
R 150K-S 00067A	00067A RES 1/4W 5% SMD 1206	1	R8
R 270R-S 00034A	00034A RES 1/4W 5% SMD 1206	2	R12, R15
R 47K-S 00061A	00061A RES 1/4W 5% SMD 1206	4	R3, R7, R11, R14
R 5K6-S 00050A	00050A RES 1/4W 5% SMD 1206	3	R6, R10, R13
R 68K-1%-S 00063B	00063B RES 1/4W 1% SMD 1206	1	R4
R 6K8-S 00051A	00051A RES 1/4W 5% SMD 1206	1	R5
TR BC847 03456	03456 NPN SMD TRANSISTOR	4	TR1-4

Component layout SCH0312AR0

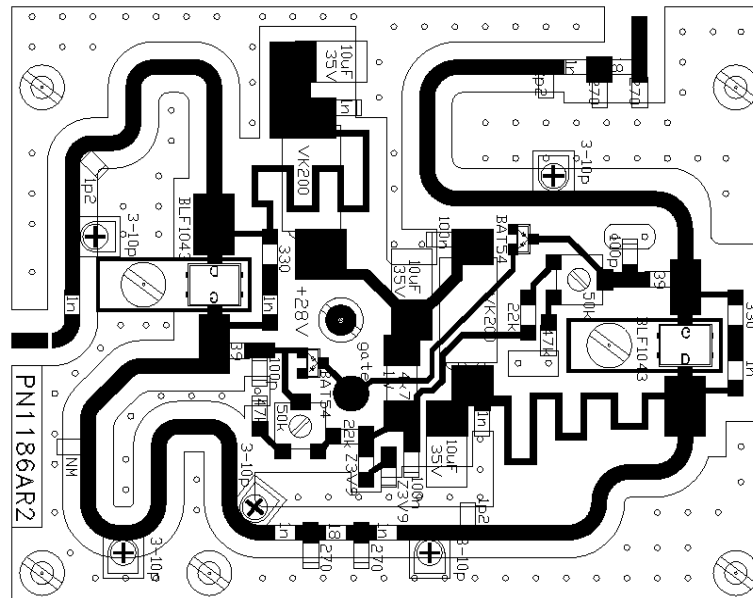

COMPONENT LIST SCH0312AR0

Part Name/Number	Description	Qty.	Comps.
CC 100nF-S 01065C	01065C Y5V 1206 COND	2	C5, C8
CC 100pF-S 01092	01092 SMD 1206 COND	2	C4, C23
CC 1nF-S 01096	01096 SMD 1206 COND	8	C1, C6, C10, C12, C15, C17, C20, C21
CC 1p2F-S 01081	01081 SMD 1206 COND	2	C14, C18
CC 2p2F-S 01081B	01081B SMD 1206 COND	1	C2
CE 10uF35V-S 01628A	01628A TANTALIUM ELETTR SMD CO	3	C7, C9, C22
CV 3-10pF-S 01475	01475 VARIABLE COND	5	C3, C11, C13, C16, C19
DBAT54S	03199 SMD SCHOTTKY DIODE A-K T	2	D1-2
DZ 3V9 03107	03107 ZENER DIODE	2	DZ1-2
IND VK200 05013	05013 INDUCTOR	2	L2-3
R 18R-S 00020A	00020A RES 1/4W 5% SMD 1206	2	R2, R11
R 22K-S 00057A	00057A RES 1/4W 5% SMD 1206	2	R7, R14
R 270R-S 00034A	00034A RES 1/4W 5% SMD 1206	4	R1, R3, R10, R12
R 330R-S 00035B	00035B RES 1/4W 5% SMD 1206	2	R9, R13
R 39R-S 00024A	00024A RES 1/4W 5% SMD 1206	2	R4, R17
R 47K-S 00061A	00061A RES 1/4W 5% SMD 1206	2	R6, R16
R 4K7-1W-S	00401 RES 1W 5% SMD 2512	1	R8
RV 50K-S-H/S 00797	00797 SMD VARIABLE RESISTOR	2	R5, R15
TR BUZ30A	03020 MOSFET-N TRANSISTOR	2	TR1-2

0 1 2 3 4 5 6 7 8 9

A B C D E F G H I L

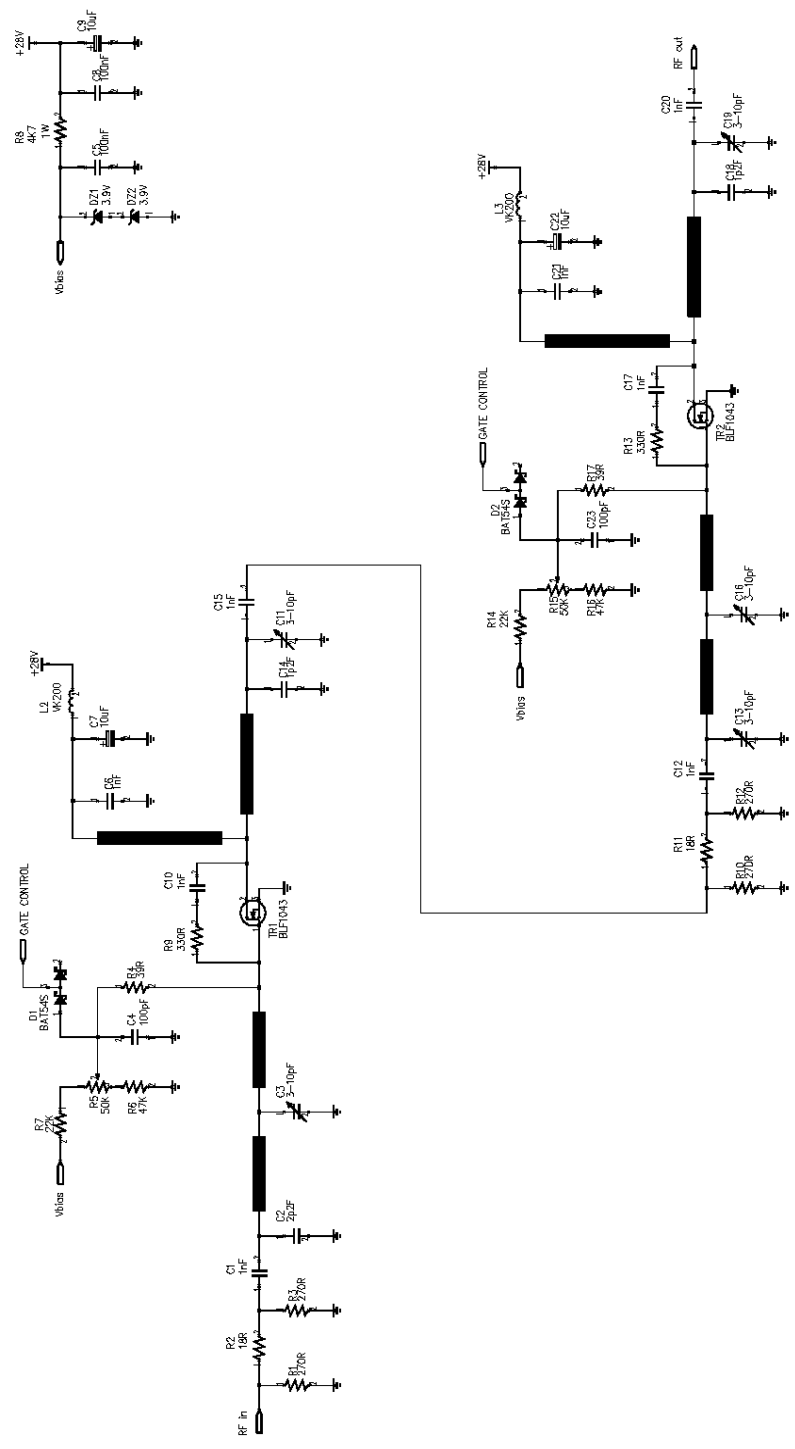

ELETRONIKA S.r.l.	ELECTRIC DIAGRAM	DESIGNER	SIGNATURE	DATE
		ASSEMBLY CODE	CAMPANA	17/01/2005
SCH0312AR0	TITLE	PCB DESIGNER	SIGNATURE	PCB REF
	2W UHF DRIVER AMPLIFIER	CAMPANA		PN1186AR2
				SHEET 1 OF 1

Component layout SCH0316AR0

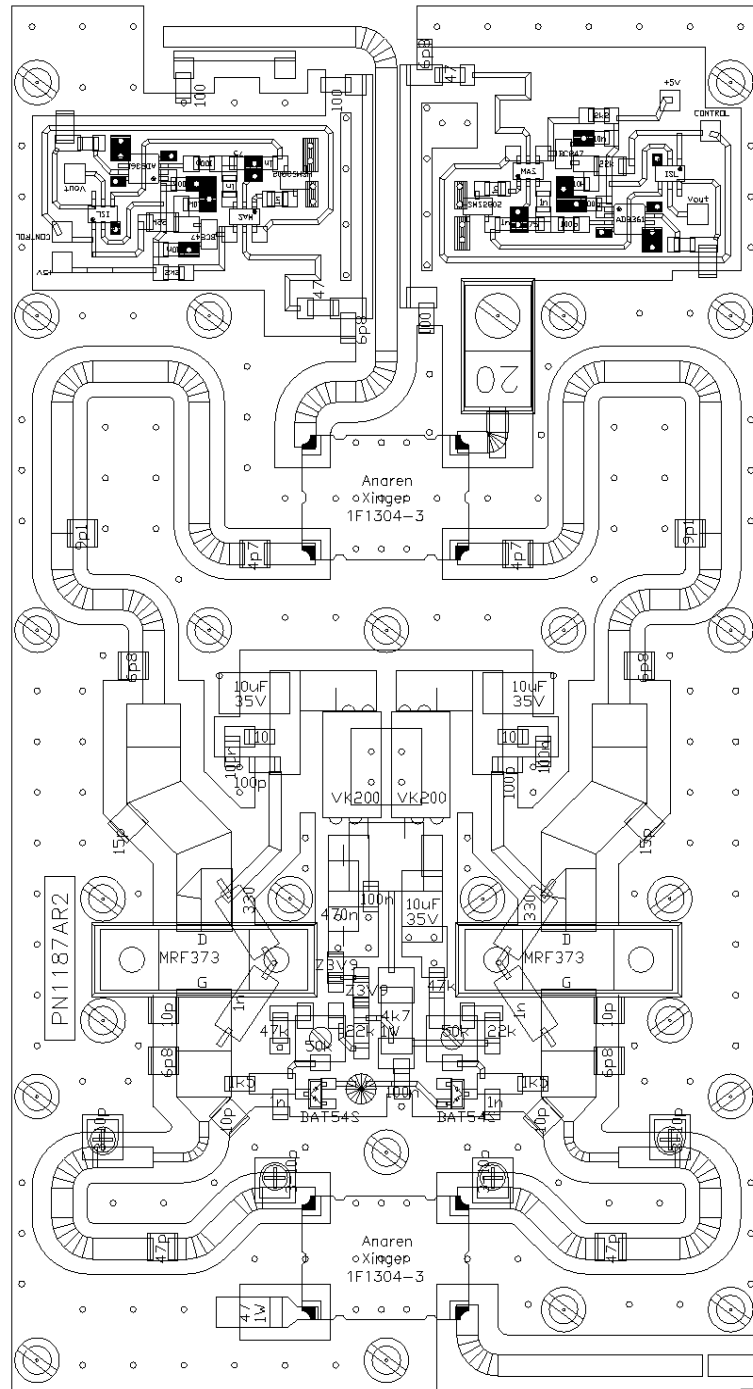

DESCRIPTION

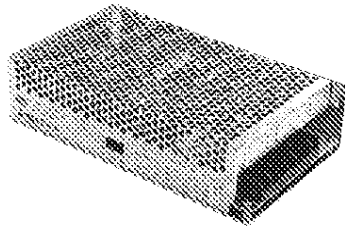

The **emi filter** block suppresses the electrical noise injected by the psu over the mains, reducing both differential and common mode noise. In this block is located a 4A fuse.

The **input rectifier and filter stage** performs the AC/DC conversion to the following high frequency power conversion. With the aid of a bipolar switches the rectified mains voltage is pulse width modulated in the **power switching stage** in order to drive the primary side of a ferrite transformer. The **output rectifier and filter stage** supplies the required DC output voltage. The fine output voltage regulation is provided by the magnetic feedback with PWM control block. This kind of implementation ensures the safety isolation between mains and load and the modulation of the primary duty cycle in order to provide a well regulated output voltage. The unit is electronically protected against current overload and output overvoltage.

TECHNICAL CHARACTERISTICS

MODEL	S-150-24
Input voltage	88~132VAC/176~264VAC selected by sw.
Input frequency	47-63Hz
Inrush current	Cold star, 35A
Output voltage	24V, 6.5A
Overload protection	105%~150% output shutdown
Over voltage protection	115%~135% of output voltage (S-150-24 125%~145%)
Setup, rise, hold up time	100ms, 50ms, 20ms
Withstand voltage	I/P-O/P: 3KV, I/P-FG: 1.5KV, 1min.
Working temp	0-30°C@100%, 50°C@100% with cooling fan, -10°C@80% (15V&24V 0-50°C@100%, 60°C@60%)
Safety standards	UL 1012, TUV EN60950
EMC standards	(EN55022), IEC801-2, 3, 4, IEC555-2
Connection	7P/9.5mm pitch terminal block
Weight	0.8kgs
Packing	20PCS/1.4CUFT
Dimensions	199x110x50mm

Type No	Output	Tol.	R&N	Effi.	P.P.
S-150-5	5V, 30A	+/-2%	150mV	78%	87
S-150-7.5	7.5V, 20A	+/-1%	150mV	80%	87
S-150-9	9V, 16.7A	+/-1%	180mV	80%	87
S-150-12	12V, 12.5A	+/-1%	180mV	82%	87
S-150-15	15V, 10A	+/-1%	180mV	84%	87
S-150-24	24V, 6.5A	+/-1%	240mV	85%	87
S-150-48	48V, 32A	+/-1%	240mV	86%	87

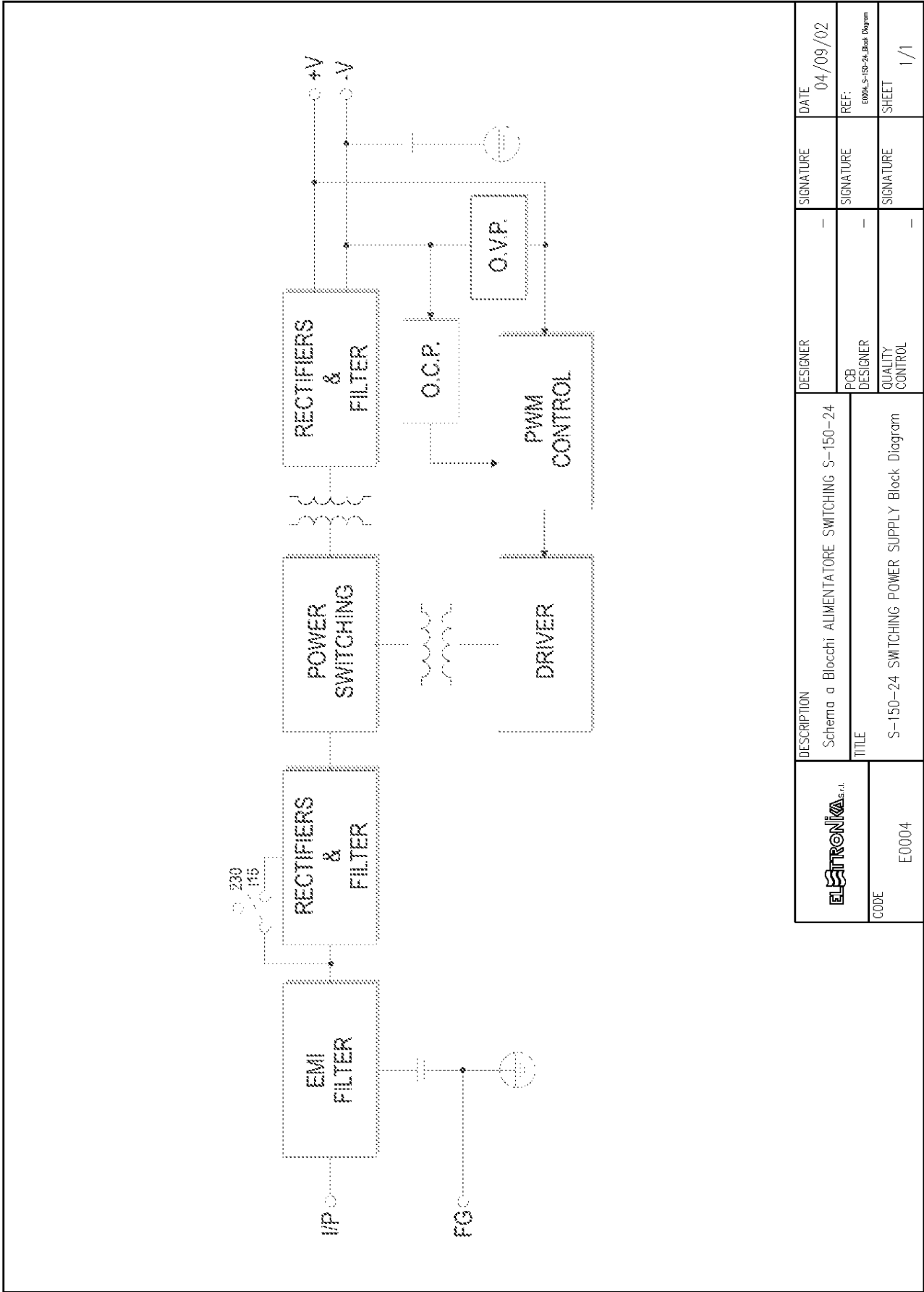

	DESCRIPTION	DESIGNER	SIGNATURE	DATE
	Schema a Blocchi ALIMENTATORE SWITCHING S-150-24 TITLE S-150-24 SWITCHING POWER SUPPLY Block Diagram	DESIGNER QUALITY CONTROL	SIGNATURE SIGNATURE SIGNATURE	SIGNATURE SIGNATURE SIGNATURE
CODE	E0004			

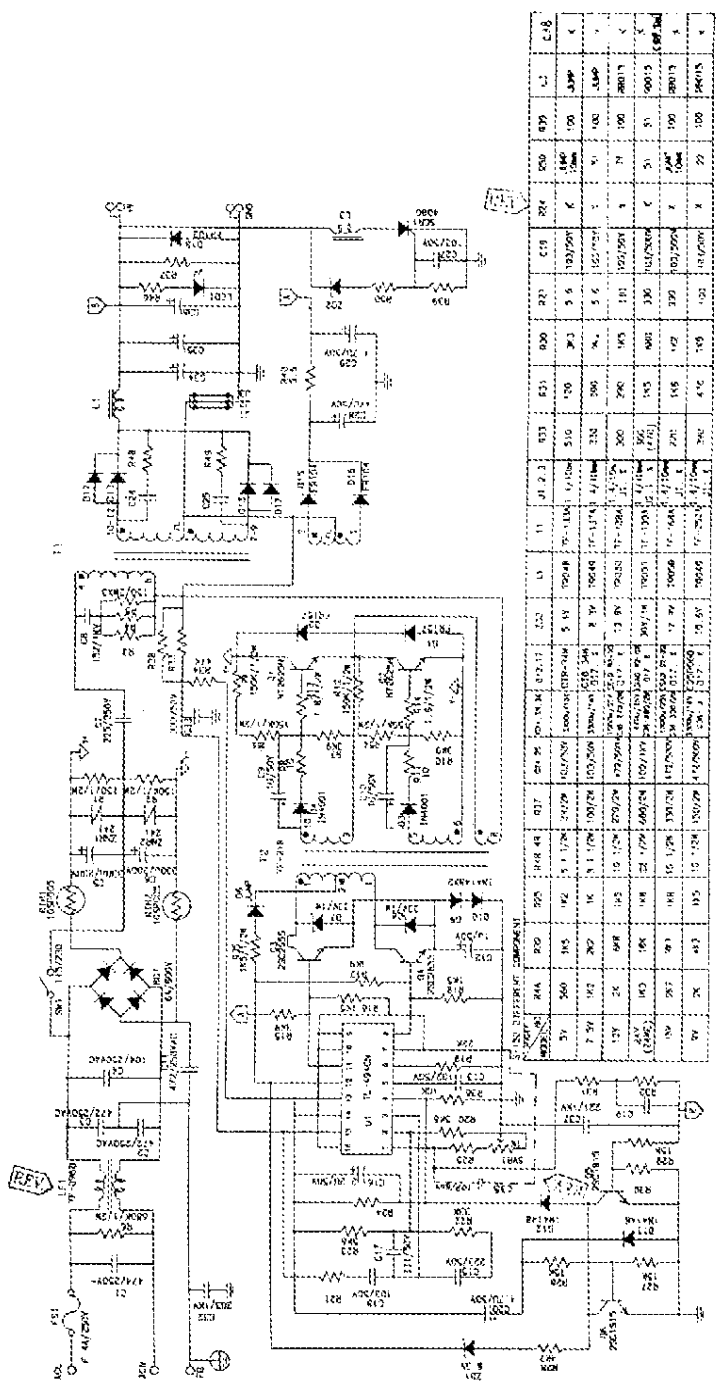

REF.	QTY	DESCRIPTION	UNIT PRICE	TOTAL PRICE
D1-D4	4	1N4007	0,10	0,40
C1	1	200µF	0,50	0,50
C2	1	100µF	0,50	0,50
C3	1	100µF	0,50	0,50
C4	1	100µF	0,50	0,50
C5	1	100µF	0,50	0,50
C6	1	100µF	0,50	0,50
R1	1	200k	0,20	0,20
R2	1	100k	0,20	0,20
R3	1	100k	0,20	0,20
R4	1	100k	0,20	0,20
R5	1	100k	0,20	0,20
M1	1	IRFP460	1,50	1,50
Q1	1	2N2222	0,10	0,10
Q2	1	2N2222	0,10	0,10
Q3	1	2N2222	0,10	0,10
L1	1	240V	1,00	1,00
L2	1	240V	1,00	1,00
L3	1	240V	1,00	1,00
U1	1	7805	0,50	0,50
U2	1	7805	0,50	0,50
U3	1	7805	0,50	0,50
U4	1	7805	0,50	0,50
U5	1	7805	0,50	0,50
U6	1	7805	0,50	0,50
U7	1	7805	0,50	0,50
U8	1	7805	0,50	0,50
U9	1	7805	0,50	0,50
U10	1	7805	0,50	0,50
U11	1	7805	0,50	0,50
U12	1	7805	0,50	0,50
U13	1	7805	0,50	0,50
U14	1	7805	0,50	0,50
U15	1	7805	0,50	0,50
U16	1	7805	0,50	0,50
U17	1	7805	0,50	0,50
U18	1	7805	0,50	0,50
U19	1	7805	0,50	0,50
U20	1	7805	0,50	0,50
U21	1	7805	0,50	0,50
U22	1	7805	0,50	0,50
U23	1	7805	0,50	0,50
U24	1	7805	0,50	0,50
U25	1	7805	0,50	0,50
U26	1	7805	0,50	0,50
U27	1	7805	0,50	0,50
U28	1	7805	0,50	0,50
U29	1	7805	0,50	0,50
U30	1	7805	0,50	0,50
U31	1	7805	0,50	0,50
U32	1	7805	0,50	0,50
U33	1	7805	0,50	0,50
U34	1	7805	0,50	0,50
U35	1	7805	0,50	0,50
U36	1	7805	0,50	0,50
U37	1	7805	0,50	0,50
U38	1	7805	0,50	0,50
U39	1	7805	0,50	0,50
U40	1	7805	0,50	0,50