



User's Manual

TXUD1000/ATSC UHF TV Transmitter

CODE	APT205L/DIG	TITLE	TXUD1000/ATSC UHF TV TRANSMITTER	REV	1	DATE	03/08/09
------	-------------	-------	----------------------------------	-----	---	------	----------



Registration number: **IT-17686**



Registration number: **IT-24436**

CE 0682 

SS 96 Km 113
70027 Palo del Colle (Ba) **ITALY**
Tel. +39 (0)80 626755
Fax +39 (0)80 629262
E-mail: elettronika@elettronika.it
Web site: <http://www.elettronika.it>

WARNING

The apparatus described in this manual has been designed and manufactured with devices to safeguard the users. In any case it is recommended that during any operation of installation, maintenance, miscellaneous interventions and calibrations requiring the apparatus to be switched on,

THE USER TAKES ALL THE PRECAUTIONS AGAINST INCIDENTS

It is required to use the proper clothes and protection gloves in order to prevent damages from incidental contacts with high-voltage parts.

The manufacturer declines every responsibility in case the recommendations above are not followed.

IMPORTANT

The component lists attached to the relevant electrical diagrams indicate for each item the reference, the description and the type normally used.

The ***Eletronika S.r.l.*** though reserves the right to use or supply as spare parts components with equivalent characteristics but of a different type, assuring anyway the optimal work of the apparatus in accordance with the specifications.

The enclosed monographs are solely owned by ***Eletronika S.r.l.***

The use of anything enclosed in this technical manual without explicit authorization given by ***Eletronika S.r.l.*** will be prosecuted by the law.

The data and technical characteristics of the apparatus described in this manual are not compelling for the manufacturer.

The ***Eletronika S.r.l.*** reserves the right to make, without previous notice, modifications or updates in order to improve the quality of the product.

The general conditions of supply and sale are described in the contracts.

The delivery time are in accordance with the products and quantities ordered.

Summary of warranty

We, ELETTRONIKA S.r.l., SS096 Km 113 Z.I. PALO DEL COLLE (BA) ITALY, warrant to the ORIGINAL PURCHASER of a NEW product, for a period of one (1) year from the date of purchase by the original purchaser (the "warranty period") that the new ELETTRONIKA product is free of defects in materials and workmanship and will meet or exceed all advertised specifications for such a product. This warranty does not extend to any subsequent purchaser or user, and automatically terminates upon sale or other disposition of our product.

Items excluded from this ELETTRONIKA warranty

We are not responsible for product failure caused by misuse, accident, or neglect. This warranty does not extend to any product on which the serial number has been defaced, altered, or removed. It does not cover damage to loads or any other products or accessories resulting from ELETTRONIKA product failure. It does not cover defects or damage caused by use of unauthorized modifications, accessories, parts, or service.

What we will do

We will remedy any defect, in material or workmanship (except as excluded), in our sole discretion, by repair, replacement, or refund. If a refund is elected, then you must make the defective or malfunctioning component available to us free and clear of all liens or other encumbrances. The refund will be equal to the actual purchase price, not including interest, insurance, closing costs, and other finance charges less a reasonable depreciation on the product from the date of original purchase. Warranty work can only be performed at our authorized service centers or at our factory. Expenses in remedying the defect will be borne by ELETTRONIKA, including one-way surface freight shipping costs within the United States. (Purchaser must bear the expense of shipping the product between any foreign country and the port of entry in the United States and all taxes, duties, and other custom's fees for such foreign shipments).

How to obtain warranty service

You must notify us of your need for warranty service not later than ninety (90) days after the expiration of the warranty period. We will give you an authorization to return the product for service. All components must be shipped in a factory pack or equivalent which, if needed, may

Disclaimer of consequential and incidental damages

You are not entitled to recover from us any consequential or incidental damages resulting from any defect in our product. This includes any damage to another product or products resulting from such a defect.

Warranty alterations

No person has the authority to enlarge, or modify this warranty. The warranty is not extended by the length of time for which you are deprived of the use of the product. Repairs and replacement parts are provided under the terms of this warranty shall carry only the unexpired portion of this warranty.

Design changes

We reserve the right to change the design of any product from time to time without notice and with no obligation to make corresponding changes in products previously manufactured.

Legal remedies of purchaser

There is no warranty which extends beyond the terms hereof. This written warranty is given in lieu of any oral or implied warranties not contained herein. We disclaim all implied warranties, including without limitation any warranties of merchantability or fitness for a particular purpose. No action to enforce this warranty shall be commenced later than ninety (90) days after expiration of the warranty period.

Warranty for electronic tubes

The warranty applied for electronic tubes is the one given by the manufacturer of the tube. In the event that the product shows anomalies within the deadline of the validity of the warranty given by the manufacturer of the product itself, the buyer will have to return it to the seller with the needed documents and the written description of the defect. The seller will ship the broken tube to the manufacturer in order to effect the necessary technical tests to find out the cause of the anomaly. Meanwhile the buyer of the tube who needs to use, and as such to replace immediately the product, will have to buy a new one and provide to the relevant payment, further to the issuing by the seller of a regular commercial invoice. After the adequate tests made by the manufacturer, should the result be positive, that is confirm the defect in manufacturing, the seller will issue a regular credit note in the name of the buyer and return the amount paid. Should the result be negative, that is detect a negligence in the installation or use by the buyer, he will have no right against the seller.

INTRODUCTION

The apparatus described in this manual is the latest of this series, offering high performances, remarkable reliability and a wide range of characteristics, it all at a competitive cost.

Its is easy to install and use. It only takes to follow the installation procedure as shown in this manual: after having removed all from the package, you only have to follow step by step the description in the various sections.

Before starting to use the apparatus, remember to:

- read carefully the general safety information contained in this section;
- follow the instructions for the installation and set up of the apparatus;
- read all the remaining sections of this manual in order to know well the apparatus and learn how to obtain the best of its characteristics.

CONTENTS OF THE MANUAL

The chapter composing this manual contain all the information concerning the use of the apparatus. For more information refer to ELETTRONIKA S.r.l.

This manual is made up of different chapters, each made up of various sections.

WARNING!

The currents and voltages in this equipment are dangerous!
Personnel must at all times observe safety regulation!

This manual is intended as a general guide for trained and qualified personnel who are aware of the dangers inherent in handling potentially hazardous electrical and electronic circuits. It is not intended to contain a complete statement of all safety precautions which should be observed by personnel in using this or other electronic equipment.

The installation, operation, maintenance and service of this equipment involves risks both to personnel and equipment, and must be performed only by qualified personnel exercising due care. Elettronika S.r.l. shall not be responsible for injury or damage resulting from improper procedures or from the use of improperly trained or inexperienced personnel performing such tasks.

During installation and operation of this equipment, local building codes and fire protection standards must be observed.

WARNING!

Always disconnect power before opening covers, doors, enclosures, gates, panels or shields.
Always use grounding sticks and short out high voltage points before servicing. Never make internal adjustments, perform maintenance or service when alone or when fatigued.

Do not remove, short-circuit or tamper with interlock switches on access covers, doors, enclosures, gates, panels or shields.
Keep away from live circuits, know your equipment and don't take chances.

WARNING!

In case of emergency ensure that power has been disconnected.

Treatment of electrical shock

1) If victim is not responsive follow the A, B, C's of basic life support.

PLACE VICTIM FLAT ON HIS BACK ON A HARD SURFACE

A - AIRWAY



If unconscious, open airway lift up neck, push forehead back, clear out mouth if necessary, observe for breathing.

B - BREATHING

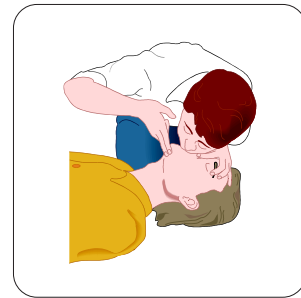

If not breathing, begin artificial breathing. Tilt head, pinch nostrils, make airtight seal, 4 quick full breaths. Remember mouth to mouth resuscitation must be commenced as soon as possible.

C - CIRCULATION

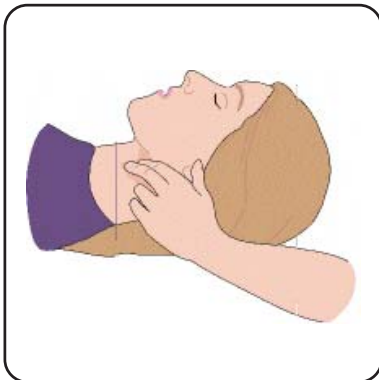

Check carotid pulse. If pulse absent, begin artificial circulation.

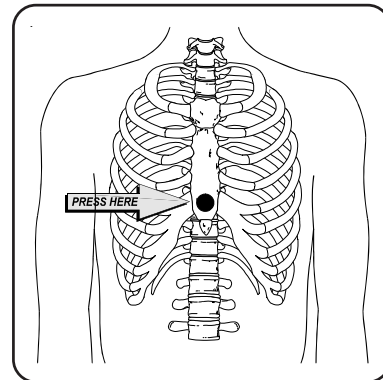

Approx. 80sec.: 1 rescuer, 15 compressions, 2 quick breaths.

Approx. 60sec.: 2 rescuers, 5 compressions, 1 breath.

NOTE: DO NOT INTERRUPT RHYTHM OF COMPRESSIONS WHEN SECOND PERSON IS GIVING BREATH.

Call for medical assistance as soon as possible.

2) If victim is responsive:

- keep them warm;
- keep them as quiet as possible;
- loosen their clothing (a reclining position is recommended).

FIRST-AID

Personnel engaged in the installation, operation, maintenance or servicing of this equipment are urged to become familiar with first-aid theory and practices. The following information is not intended to be a complete first-aid procedure, it is brief and is only to be used as a reference. It is the duty of all personnel using the equipment to be prepared to give adequate Emergency First Aid and thereby prevent avoidable loss of life.

TREATMENT OF ELECTRICAL BURNS

1) Extensive burned and broken skin.

- Cover area with clean sheet or cloth (cleansed available cloth article);
- do not break blisters, remove tissue, remove adhered particles of clothing, or apply any salve or ointment;
- treat victim for shock as required;
- arrange transportation to a hospital as quickly as possible;
- if arms or legs are effected keep them elevated.

NOTE

If medical help will not be available within an hour and the victim is conscious and not vomiting, give him a weak solution of salt and soda: 1 level teaspoonful of salt and 1/2 level teaspoonful of baking soda to each quart of water (neither hot or cold).

Allow victim to sip slowly about 4 ounces (half a glass) over a period of 15 minutes.

Discontinue fluid if vomiting occurs (do not give alcohol).

2) Less severe burns - (1st & 2nd degree).

- Apply cool (not ice cold) compresses using the cleansed available cloth article;
- do not break blisters, remove tissue, remove adhered particles of clothing, or apply salve or ointment;
- apply clean dry dressing if necessary;
- treat victim for shock as required;
- arrange transportation to a hospital as quickly as possible;
- if arms or legs are affected keep them elevated.

Communication N°1 -2002/95/CE - RoHS Directive

Further to the directives issued by the European Community, 2002/95/CE, 2002/95/CE and 2003/108/CE, and to the Italian Decree of Law n° 151 dated 25 July 2005, this is to inform the customers of Elettronika S.r.l. living within the boundaries of the European Community about the following obligations:

- 1) It is forbidden to trash RAEE products (which includes all broadcasting products which are not expressly labelled as lead-free) along with normal wastes;
- 2) Such devices must be brought to proper centres able to perform the adequate processing in order to recycle their parts where possible and dispose of the raw materials contained therein;
- 3) For equipment purchased from Elettronika after the 13th of August 2005, the gathering, transport, processing, recycle and disposal operations are responsibility of Elettronika who will bear all related expenses;
- 4) For equipment purchased from Elettronika before the 13th of August 2005, the gathering, transport, processing, recycle and disposal operations are responsibility of Elettronika, who will bear all related expenses, only if you are purchasing from us new equipment in substitution of the disposed one;
- 5) Electric and electronic devices contains lead in soldering, cables, etc. This substance pollutes the environment and may be accumulated in the organism of plants and mammals. It is dangerous for humans because it may affect blood, bone marrow, peripheral and central nervous system and kidneys, causing anaemia, encephalopathies (e.g., convulsions), peripheral neuropathies, cramps of the abdomen and kidney damages. Besides it affects human reproduction and growth.
These devices also contain mercury. From the environmental point of view, this substance is highly toxic for aquatic life, and can be accumulated in the organism of fish.
Long-term damages to humans can affect the central nervous system and the kidneys, producing irritability, emotional instability, tremors, damages to the mind and the memory, language disorders. It may also irritate and whiten the gums, and its effects may be cumulative. Based on tests on animals, it may affect the human reproduction or growth.
There is also chrome, which may result in irritation of the eyes and respiration system.
Cadmium is also present. In humans it may damage lungs, due to repeated or prolonged contact with its dust, and kidneys. It may cause cancer.
- 6) The symbol below marks the devices which cannot be disposed of along with normal wastes, as stated in 1) and 2) above.



- 7) The payment of fees is foreseen for the non-allowed disposal of such devices.

This page is intentionally blank



TXUD1000/ATSC UHF TV TRANSMITTER

User's manual

TXUD1000/ATSC UHF TV TRANSMITTER

DESCRIPTION

The TXUD1000/ATSC belongs to the High Power UHF products family of Television Transmitters fully in LDMOS solid state technology.

The TXUD1000/ATSC series represents the 1kW TV ATSC transmitter operating in the UHF Band for Common amplification process (separate amplification available) of the Video and Audio carriers and for Digital TV signals of different standards. This transmitters family has been designed to offer to the customer high performances, high reliability and greater simplicity in their operation and maintenance procedures.

The Video and Audio signal processing is provided for all Analogue and Digital TV Standards and all types of Audio applications (Mono and Dual Sound - NICAM) together with colour systems such as PAL - NTSC - SECAM. The transmitter ensures optimal performance also with Digital TV signals (DVB-T, ATSC, DTMB, etc.). Thanks to the amplitude and phase pre-correction circuit, it is possible to cancel the distortions in the output stage, thus cutting down the operating costs. The RF transposition in the driver is carried out by a synthesizer with various possibilities of accuracy and stability as well as precision offset locked by internal or external frequency reference.

When equipped with a dual-mode exciter (Analogue and DVB-T), the transmitter can quickly and easily switch from analogue broadcasting mode to DVB-T broadcasting mode (and vice versa), to enable a comfortable operation during the transition period to the full-digital broadcasting time.

The RF Amplifier is made up by two RF Amplifier Modules installed in a power rack; the modules are dedicated for the Video and Audio carriers common amplification and for Digital TV amplification. The amplifiers employ solid state LDMOS technology in order to obtain wide band, reliability, and high efficiency. Each RF module has a built-in switching-mode power supply unit, self-protected against overcurrents and overvoltages, as well as overtemperature and VSWR for RF parameters. The cooling system is fully contained into the transmitter. The Amplifier Control unit provides full management of the transmitter without the presence of the operator, the system includes a central controller and several peripheral units installed in each RF module and rack. Controller and peripherals are connected by a RS485 full-duplex bus.

Power supply output voltages and currents, Forward and Reflected Powers of any single power amplifier are monitored by Amplifier Control unit.

In that way there is a single interface point between user and all the transmitter. The operator interface is made by a high resolution LCD graphic display and a simple keyboard, the menu is very friendly and easy to use.

The Amplifier Control unit can be fully controlled in 'remote' mode via link or via modem in RS232 or other interface.

The equipment design allows the soft degradation (RF power loss) for several transistors faults.

TECHNICAL CHARACTERISTICS

RF SECTION

Analog Operation

Frequency Range	470 - 860MHz
Output Power	2.5kW PEP
Gain (± 2)	27dB
Video / Audio Power Ratio	10/1 single sound - 20/1/0.2 dual sound
Out Stage Technology	Solid State LDMOS
Video / Audio Amplification	Common
Standards	G, K, I, M
Sound Transmission	FM single sound - Dual sound coding IRT - NICAM 728
Harmonics and Suppression Emission	In compliance with CCIR rec.
Intermodulation Products from Video and Audio	≤ 50 dB
Frequency Stability	2.5ppm (option 0.05ppm)
RF Input Connector	N Female
RF Output Connector	EIA 1+5/8"

Digital Operation

Output Power (DVB-T)	600W RMS
Output Power (ATSC)	1000W RMS
DVB-T Modes	All the modes listed in ETSI EN 300 744
DVB-T MER	≥ 33 dB RMS
DVB-T Shoulders Attenuation (After non-critical mask 6-cavity filter)	≥ 40 dB RMS
DVB-T Output Spectrum	Compliant ETSI EN 300 744
ATSC Symbol Rate	10.76MBaud/s (Compliant to ATSC Doc. A/53)
ATSC SNR	≥ 27 dB RMS
ATSC Shoulders Attenuation (After simple mask cavity filter ref. total output power)	≥ 46 dB RMS
ATSC Output Spectrum	Compliant to ATSC Doc. A/64

VIDEO SECTION

Video Input	BNC 75 Ω Connector
Nominal Input Level	1V _{pp} ± 6 dB
Return Loss	≥ 30 dB
DC Restoration	Clamped to the blanking level without affecting the burst
White Limiter	At 90% picture signal without affecting the chrominance

Transmission characteristics

Sideband Spectrum Response	According to the standard
Amplitude Frequency Response	According to the standard
Group Delay variation without receiver pre-correction and TV demodulator flat	$\leq \pm 35$ ns
Non Linearity Distortion (10 to 75% mod.)	$\leq 5\%$
Differential Gain (10 to 75% mod.)	$\leq 5\%$
Differential Phase (10 to 75% mod.)	$\leq 5^\circ$
Signal to random noise ratio (weighted 0.2 to 5MHz)	≥ 60 dB
Blanking Level Variation	$\leq 2\%$
2T k Factor	$\leq 2\%$

AUDIO SECTION

Nominal Input Level (± 50 kHz dev.)	-10 to +8dBm
Input Impedance	600 Ω balanced
Pre-emphasis	50 μ s

Transmission characteristics

Amplitude Frequency Response	40 to 15000Hz ± 0.5 dB
Total Harmonic Distortion	$\leq 0.5\%$
FM Signal to noise ratio (referred to ± 50 kHz dev. $f = 400$ Hz)	≥ 60 dB (weighted)
AM Signal to noise ratio	≥ 50 dB (referred to 100%)
AM Synchronous Modulation	≥ 40 dB (referred to 100%)

METERING

Output Forward Power (Peak or RMS)
Output Reflected Power (Peak or RMS)
Unbalance Power (last unbalance load in output combiner)
Transmitter Temperature
Power Amplifier Forward Power (Peak or RMS)
Power Amplifier Reflected Power (Peak or RMS)
Power Amplifier Input Power (Peak or RMS)
Power Amplifier Heatsink Temperature
Pallet Current
Power Supply Voltage
Working Timer

INDICATIONS

Cooling Blower Working (with icon on front display)
Transmitter Interlock (with icon on front display)
Alarm (with red LED on front panel)
Transmitter ON/OFF (with green LED on front panel)
Remote ON/OFF (with orange LED on front panel)
Input Mains Phase Missing (with green LED on Power Control panel)

PROTECTIONS

Mains Phase Lack
Output Forward Power
Output Reflected Power
Rack Cooling Failure
Power Amplifier Forward Power
Power Amplifier Reflected Power
Power Amplifier Heatsink Temperature
Module Current
Power Supply Voltage

REMOTE CONTROL SECTION

Parallel Interface	ON/OFF, Alarms, Interlock
Serial Interface	RS232 or RS485 (Full monitoring and management)

GENERAL

Power Supply Voltage	3P+N 380V ±15%, 3P+N 230V ±15%
Power Supply Frequency	47 - 63Hz
Power Factor	> 0.98
Analog Power Consumption (Black)	6.45kVA
Digital Power Consumption (DVB-T / ATSC)	4.5 / 5.1kVA
Housing (Rack / Height)	1 Rack / 28U
Weight	300kg
AirFlow	2000m ³ /h
Temperature	-5°C to +45°C

Specifications and characteristics are subject to change without notice

INSTALLATION REQUIREMENTS

This section explain how to install and configure the transmitter for your location All internal switching and setup should be done by qualified service person.

PARAMETER	REQUIREMENTS
TRANSMITTER ROOM	The room should be clean and free of dust. The building floor should be able to support a load capacity >1000kg/m²
INSTALLATION AREA	The transmitter should be installed to have space around enough for ventilation and for maintenance actions to be allowed. The minimum requirement space is one meter outer boundary of transmitter.
TEMPERATURE	The transmitter is designed to work from -5° up to 45°C , anyway to ensure long life is better to keep the room temperature lower than 35°C.
ELECTRICAL PLANT	The transmitter power consumption is <6.7kVA , we suggest to design the main power line capacity increased by at least more than 50% .
MAINS SYSTEM	The mains system should be three phase with neutral. The transmitter is available in two different mains voltage models for 380VAC and 230VAC system.
AIR COOLING	The outlet air should be conveyed out of the room by suitable ducts (the transmitter air output adapters has a diameter of 320mm). The air flow required is 2000m³/h .
ANTENNA	The transmitter RF output interface is EIA 1+5/8" (others interface can be supplied on request in order to match the antenna feeder or combiner input). The RETURN LOSS of the system should be greater than 27dB in the operation channel.

Note: the standard cooling system is supplied with internal ventilation system, air inlet and outlet are on the top. Other different installations can be proposed for various air connection arrangements.

SWITCH ON PROCEDURE

Before to switch on the Transmitter is extremely important to check:

- The right connections for the RF system (antenna or external combiner) and take greatest care for the Inner in each coaxial connections;
- the right connections with the Mains Power Supply network, the Neutral line must be present and connected, and the correspondence with the voltage nominal value request;
- the right working of the earth-ground connections system, for people safety and transmitter right operation;
- the right connections inside the transmitter with input/output RF cable to/from amplifier block and combiner/divider system, if for transport or installation reason you had disconnected them before.

To follow with first switch on please follow the below indications:

- Set in OFF position all the frontal switch, Main, Amplifier Control and Amplifiers Block;
- turn ON the Mains and the Amplifier's switch. The Amplifier Control checks the communications with the amplifier block. If the communication is ok you can turn ON the Amplifier Control, now automatically the rack's blowers and the exciter are switched ON;
- give little power in to the amplifier and check if all the indicator are in the right situation (no reflected, no unbalance on the Amplifier Control, more or less the same indication for current and power for all the amplifiers block);
- increase the power slowly slowly. At rated maximum output power some watts might be shown as Reflected Power due to isolation of directional coupler or return loss from antenna system.

EXCITER DESCRIPTION

The ATSC TRANSMITTER is an 8-VSB ATSC professional exciter, designed for the most demanding digital TV broadcasting applications. It integrates a modulator module with up-to-date FPGA technology and advanced digital signal processing algorithms in order to generate an absolutely accurate output 8-VSB signal, with exceptionally optimized modulation and the output filtering techniques.

Very high linearity performances are possible thanks to very careful RF design over the entire VHF and UHF bands and with an optimal digital precorrection engine working simultaneously in the time and frequency domains. A high degree of reliability is guaranteed, moreover, by the use of oversized cooling devices and by control circuits operated by modern microprocessor technologies.

The ATSC TRANSMITTER can be used as a stand-alone 5W RMS transmitter or as a driver stage for amplifiers of greater power. The excellent spectral purity of the conversion oscillator lets the ATSC TRANSMITTER radiate an 8-VSB signal with an excellent MER value.

The ATSC TRANSMITTER is equipped with a powerful ASI/SMPTE inputs management block which

allows to manage the Transport Stream (TS) inputs in a fully redundant configuration, thus significantly improving the reliability of the whole broadcasting system in every operating condition.

The ATSC TRANSMITTER is totally compliant to the A/53, A/54 and A/64 ATSC recommendations with 6MHz output channel bandwidth, in VHF and UHF bands.

RF AMPLIFIER MODULE DESCRIPTION

The RF Amplifier Modules placed in the TXUD1000/ATSC Transmitter station are equipment designed to simplify transport and installation. Born to ensure high working reliability they excel also for their great performance. Thanks to the excellent linearity of the amplifiers, achieved with the use of the state-of-the-art LDMOS (UHF) technology, these equipment allow excellent performance both with analog and digital TV signals. The design redundancy (a power supply for every MOS device), the oversized unbalanced power dummy loads, the wide input range of the switching-mode power supplies, allow a NO STOP transmission 24h per day. The temperature of the amplifiers is guaranteed by a forced air cooling system extremely noiseless. The presence of Amplifier Control that collects all measures from amplifiers and from antenna system ensure a single control point to access to all MOSFET currents, power supplies voltages, temperature of the heat sinks, amplifiers output powers together with the RF power reading of the output antenna system.

A multifunctional display on the Amplifier Control makes it possible to verify all the operating parameters of the unit. The amplifiers in the series are remotable by wired telemetry connector or by serial communication, RS232 on front panel or RS485 on rear panel of the Amplifier Control.

CHANNEL CHANGE PROCEDURE

To proceed with a channel change operation, please follow the below indications:

- Follow the channel change indications on users manual of the exciter;
- from each RF Amplifier Modules select the new closest channel frequency;
- tune the Bandpass Output Filter on new channel;
- if the difference with the two channel is less than 10 you don't need to change the power amplifier phase balance. Otherwise, connect a digital meter to a DC Monitor (BNC) on each dummy load and keep low the value, by tuning the microstrip length on the input divider;
- connect a Wattmeter and a Dummy Load;
- set the rated output power and tune the right Forward Power indication on the Amplifier Control display;
- set the output at 10% of the rated ones, swap the Forward and Reflected cable on the rear of the Amplifier Control and set the reflected indication.

The 3dB Output Coupler is a wide band type and don't need any tuning operations.

DIGITAL UPGRADE

The amplifier is ready to operate with a DVB-T signal keeping the same analogue high performance.

- Replace the analogue Bandpass Filter with a digital ones (critical or not critical mask are well supported);
- select the RMS Detector instead of peak one on Amplifier Control and on each power amplifier to have the right power indication and the new power alarm threshold;
- replace the analogue Cxciter with a DVB-T ones. If you use a DVB-T Modulator with IF output you can use the IF VEGA input;
- the output power should be around 1/4 (in DVB-T mode) or 1/3 (in ATSC mode) of the analogue rated power (for example: the 5kW = 1.2kW rms in DVB-T mode or 5kW = 2.0kW rms in ATSC mode).

Elettronika Code	Description	Qty	Page 1/2
02015	BNC CONNECTOR FOR RG 58 CABLE	4	
02201	N MALE CONNECTOR FOR RG213 CABLE	1	
02211	N CONNECTOR FOR RG58 CABLE	6	
02409	7/16" MALE CONNECTOR FOR RG213 CABLE	1	
02410	7/16" CONNECTOR FOR SP 10 CLX 160 CABLE	2	
02459	EIA 1+5/8" INNER	1	
02502	SMA SOCKET FOR RG 58 CABLE	4	
02576	RECTIFIER TAP	2	
02791	DB9 MALE SOCKET PANEL MOUNTING	5	
02871	DB9 SHELL	5	
02886	3m 16A MALE/FEMALE CABLE	1	
02893	3 WAY MALE TERMINAL BLOCK REMOVABLE	3	
02894	3 WAY FEMALE TERMINAL BLOCK REMOVABLE	3	
05447	15x16xM4 INSULATED COPPER BAR SPACERS	3	
05448	14x4x1000mm COPPER BAR FILLET	1	
06680B	UHF DTV BANDPASS FILTER	1	
06758A	500W 50Ω DUMMY LOAD	1	
06816A	3dB HYBRID COUPLER	1	
07515A	A POLES 32A CIRCUIT BREAKER	1	
07528A	2 POLES 16A CIRCUIT BREAKER	1	
07550A	1P+N 500V FUSE-HOLDER	1	
07553	220V GREEN LIGHT	1	
07558B	MODULAR TIMER FINDER	1	
07574	63A CONTACTOR	1	
07620	G025001-00-01 HIGH GRID	2	
07625	A2E250-AM06-13 EBM BLOWER	2	
07625A	3uF WIRED CAPACITOR	2	
07947	FN 256-36/47 AC FILTER	1	
07920	PVC PROTECTION	2	
08504	RG58 50Ω CABLE	7.00	
08507	RG393/U 50Ω CABLE	0.50	
08510	RG213 50Ω CABLE	0.60	
APG012C	AMPLIFIER CONTROL	1	
APG050F	POWER CONTROL	1	
APT144CM	AUTV/1500LD LDMOS UHF TV AMPLIFIER	2	
C0205	MULTIPOLAR CABLE	6.00	
C0798	PLASTIC TAP	6	
CAV1000	H05 CABLE	1	
CMS6006	1m 1/2" CABLE WITH 7/16" MALE CONNECTOR	2	
DET1069	DET1069R0 LOCK FOR CONTAINERS WITH WHEELS	4	
DET1183	DET1183R3 BAR SUPPORT GUIDE	7	
DET1184	DET1184R4 ANGULAR SUPPORT EQUIPMENT	4	
DET1201	DET1201R1 ANGULAR SUPPORT CONTAINERS	5	
DET1204	DET1204R0 OMEGA SUPPORT GUIDE	2	
DET1205	DET1205R0 GUIDE AMPLIFIER CONTROL	2	

Elettronika Code	Description	Qty
DET1287R2P	DET1287R2 DISTRIBUTION NETWORK COVERAGE	1
DET1294	DET1294R1 DIN GUIDE DISTRIBUTION NETWORK	1
DET1307	DET1307R0 SUPPORT PLUG CONNECTORS	1
DET1335R1P	DET1335R1 ANGULAR FASTENING FILTER	1
DET1337R0P	DET1337R0 ATTACHING FILTER SINGLE NETWORK	1
DET1343R2P	DET1343R2 ANGULAR SUPPORT CONTAINERS	6
DET1350R0P	DET1350R0 DIN GUIDE POWER CONTROL SUPPORT	1
DET1351R0P	DET1351R0 SUPPORT DISTRIB. NETW. COVERAGE	2
DET1362R2Z	DET1362R2 SUPPORT RACK DIRECT. COUPLER	1
DET1416R0P	DET1416R0 CAPACITORS FAN SUPPORT	1
DET1433R0P	DET1433R0 SUPPORT BAR FILTER	2
DET1646R0P	DET1646R0 CONVEYORS AMENDED	2
FUS04	4A FUSE	2
MTG0150AR0	2 WAY UHF INPUT DIVIDER	1
MTG0162DR0	DIRECTIONAL COUPLER	1
PAN0080	PAN0080R0 1U FRONT PANEL	1
PAN0081	PAN0081R0 2U FRONT PANEL	1
PAN0082	PAN0082R0 3U FRONT PANEL	1
PAN0156	PAN0156R1 3U DUMMY LOAD FRONT PANEL	1
SCH0268AR0	FAN CABLE BOARD	1
RAK0004U28	28U OMP RACK	1
V0769	BLACK PLASTIC TAP	1
V0914	AC 2 POLES DISTRIBUTOR	2
V0973	SOCKET COVER	1
V0974	SOCKET COVER	1
V0975	CABLE HEAD	1
V0976	FEMALE CONTACT	5
V0989	AC SOCKET	1

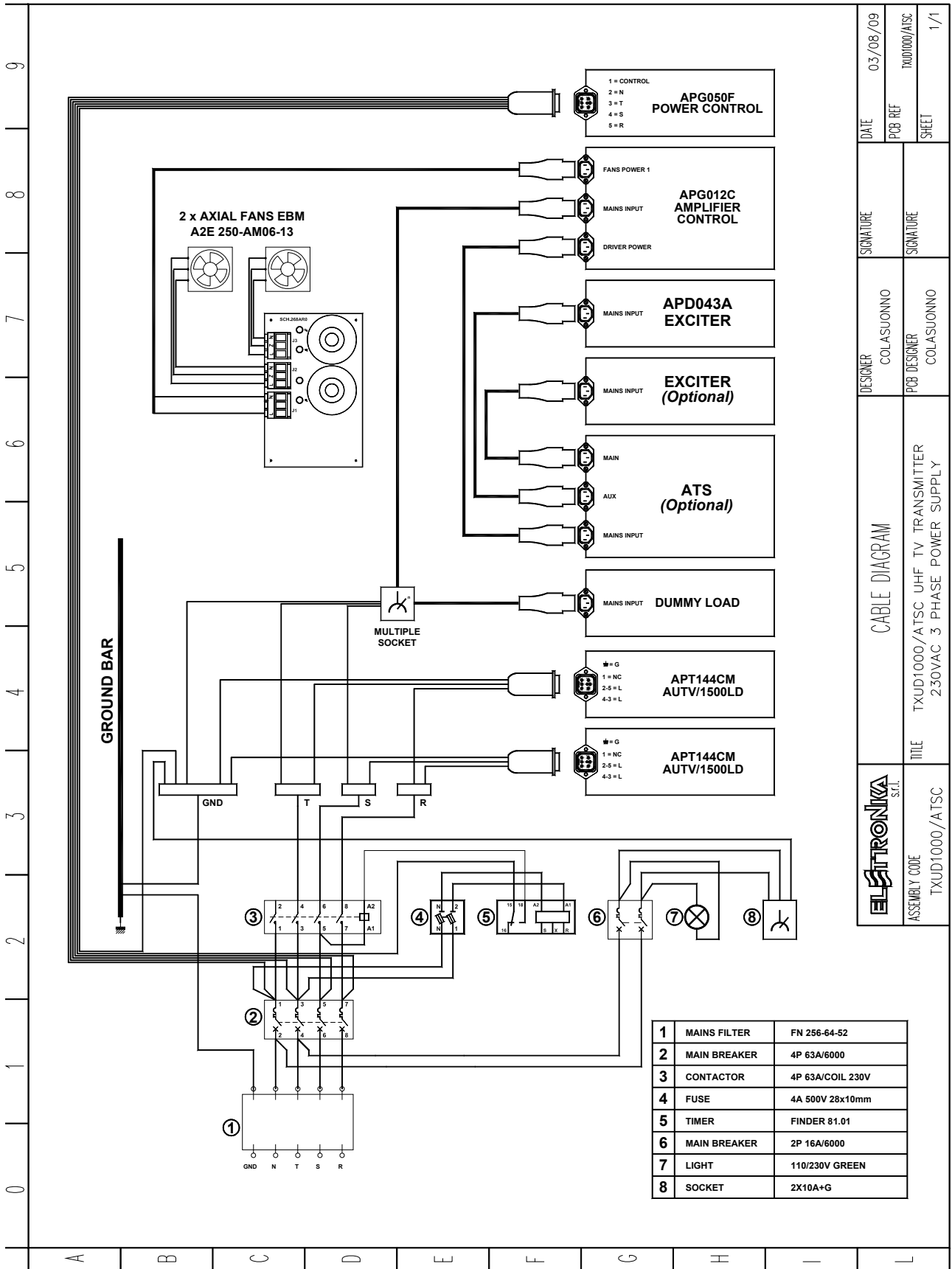

DATE	03/08/09
PCB REF	TXUD1000/ATSC
SHEET	1/1
DESIGNER	COLASUONNO
PCB DESIGNER	COLASUONNO
TITLE	TXUD1000/ATSC UHF TV TRANSMITTER 250VAC 3 PHASE POWER SUPPLY
ASSEMBLY CODE	TXUD1000/ATSC
CABLE DIAGRAM	
DESIGNER	COLASUONNO
PCB DESIGNER	COLASUONNO

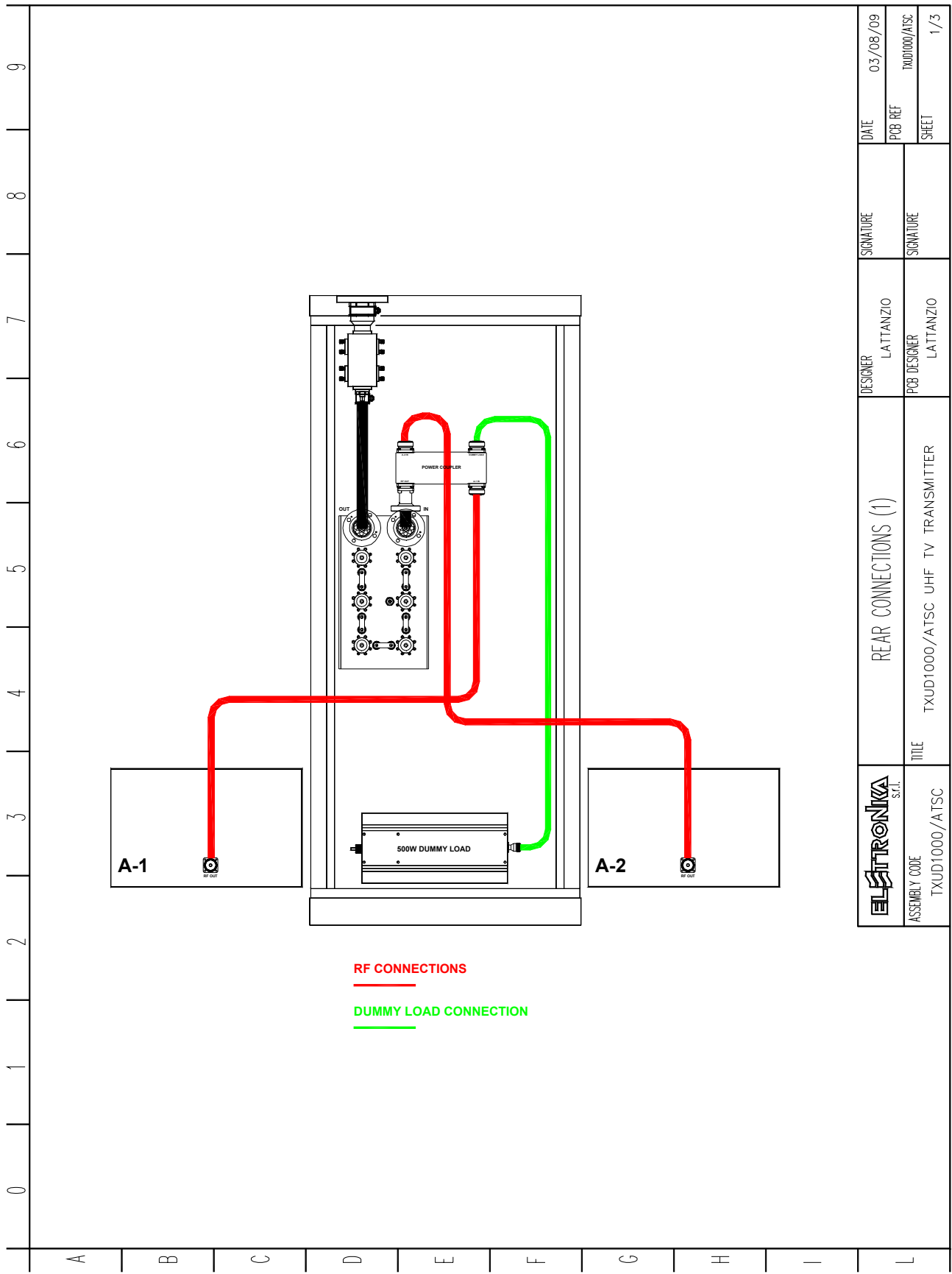

ELSTRONIKA s.r.l.	REAR CONNECTIONS (1)		DESIGNER LATTANZIO	SIGNATURE	DATE 03/08/09
	ASSEMBLY CODE TXUD1000/ATSC	TITLE TXUD1000/ATSC UHF TV TRANSMITTER	PCB DESIGNER LATTANZIO	SIGNATURE	PCB REF TXUD1000/ATSC
					SHEET 1/3

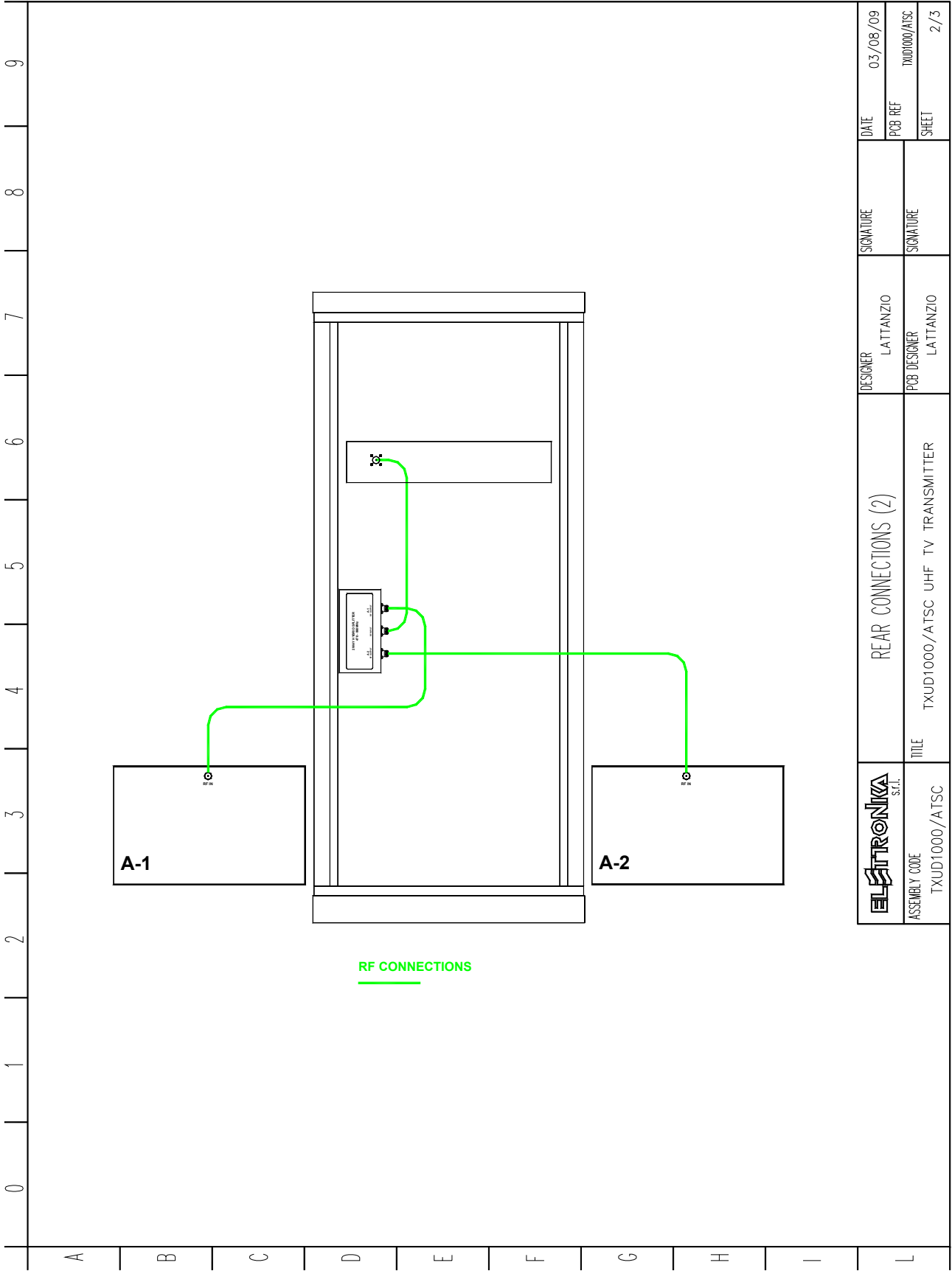

 ASSEMBLY CODE TXUD1000/ATSC	REAR CONNECTIONS (2)	DESIGNER LATTANZIO	SIGNATURE	DATE 03/08/09
	TITLE TXUD1000/ATSC UHF TV TRANSMITTER	PCB DESIGNER LATTANZIO	SIGNATURE	PCB REF TXUD1000/ATSC
				SHEET 2/3

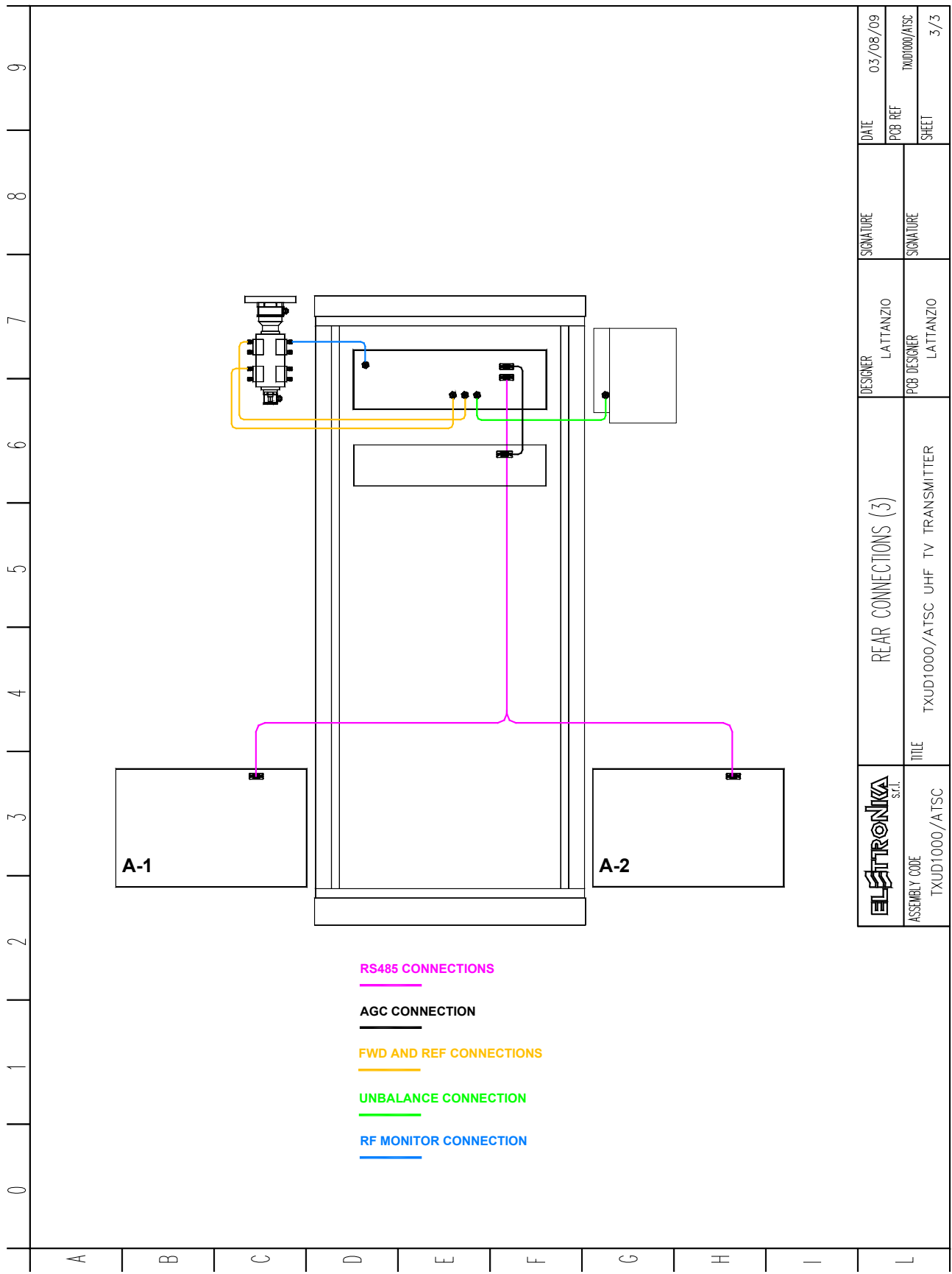

	REAR CONNECTIONS (3)	DESIGNER	SIGNATURE	DATE
	TITLE TXUD1000/ATSC UHF TV TRANSMITTER	PCB DESIGNER	SIGNATURE	PCB REF
ASSEMBLY CODE TXUD1000/ATSC				SHEET 3/3

9
8
7
6
5
4
3
2
1
0

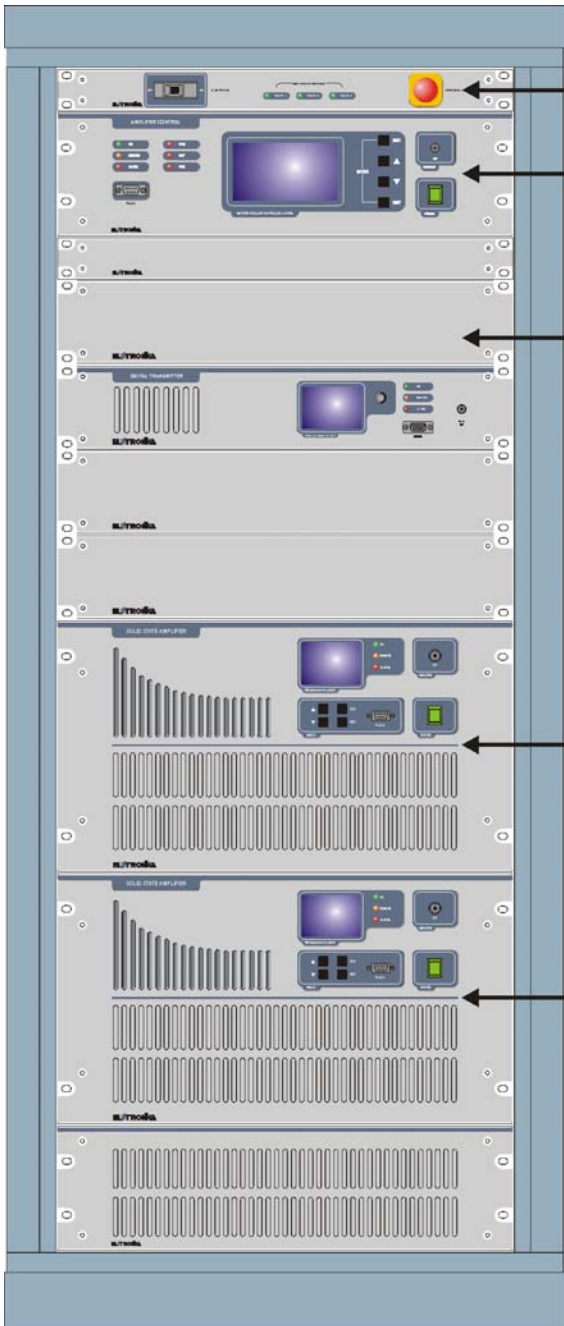

POWER CONTROL

AMPLIFIER CONTROL

ATSC TRANSMITTER
Digital TV

AUTV/1500LD
UHF TV Amplifier

A B C D E F G H I L

	FRONT VIEW	DESIGNER LATTANZIO	SIGNATURE	DATE 03/08/09
	TITLE TXUD1000/ATSC UHF TV TRANSMITTER	PCB DESIGNER LATTANZIO	SIGNATURE	PCB REF TXUD1000/ATSC
ASSEMBLY CODE TXUD1000/A TSC				SHEET 1/1

0 1 2 3 4 5 6 7 8 9

A

B

C

D

E

F

G

H

I

L

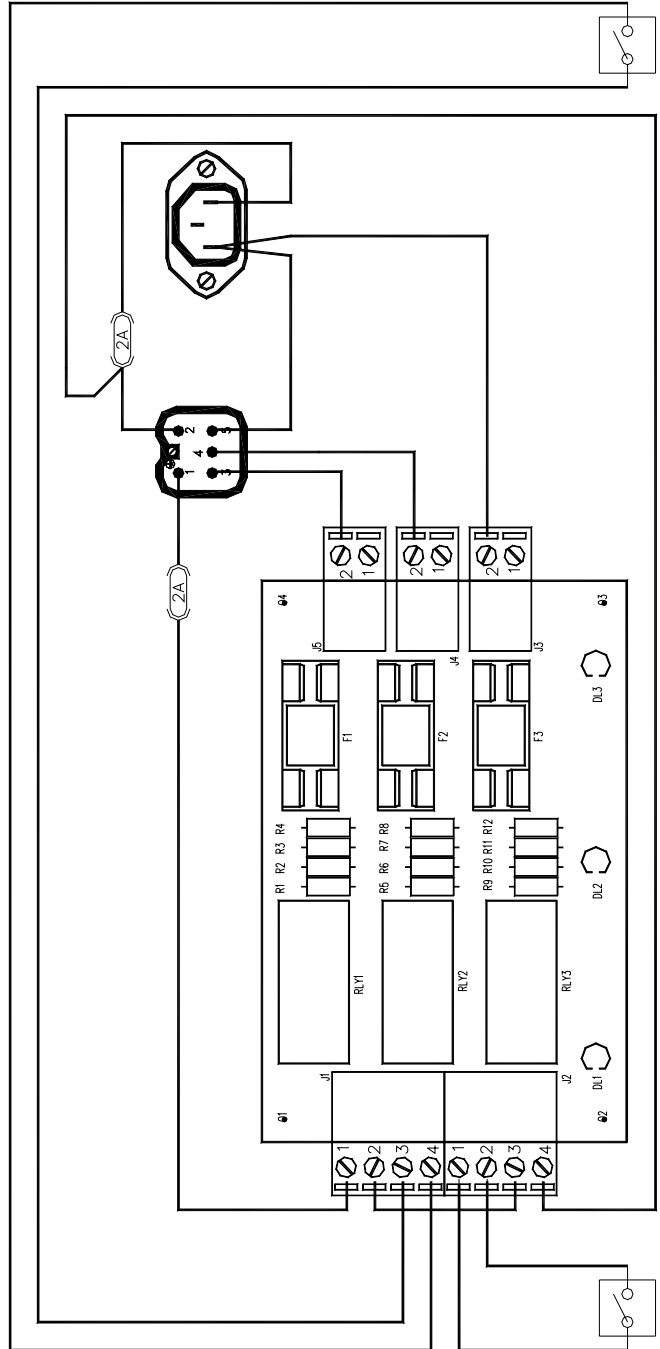

	CABLE DIAGRAM	DESIGNER COLASUONNO	SIGNATURE	DATE 13/06/06
	TITLE 380VAC THREE-PHASE POWER SUPPLY	PCB DESIGNER COLASUONNO	SIGNATURE	PCB REF AP000E
ASSEMBLY CODE APC050E				SHEET 1/1

Component list**APG050**

Elettronika Code	Description	Qty
00174	82kΩ 1/2W RESISTOR	12 (APG050F)
00178	180kΩ 1/2W RESISTOR	12
02830A	10A GREEN SOCKET	1
02881	4 WAY MALE TERMINAL BLOCK REMOVABLE	2
02882A	4 WAY FEMALE 90° TERMINAL BLOCK REMOVABLE	2
02897	2 WAY MALE TERMINAL BLOCK REMOVABLE	3
02898	2 WAY FEMALE 90° TERMINAL BLOCK REMOVABLE	3
03060	5mm GREEN LED	3
07528H	1 POLES 20A 250V CIRCUIT BREAKER	1
07541	10A FUSE-HOLDER PANEL MOUNTING	2
07543	6A FUSE-HOLDER PCB MOUNTING	3
07561A	MINIRELÈ PCB MOUNTING	3
07638	SWITCH	1
07639	EMERGENCY BUTTON	1
CON0344R1Z	CON0344R1 POWER CONTROL BOX	1
CON0346R2Z	CON0346R2 POWER CONTROL COVER	1
DET0773	DET0773R0 CIRCUIT BREAKER FASTENING	1
FUS00012	COVER FUSE	3
FUS2A	2A FUSE	5
PAN0155R2P	PAN0155R2P FRONT PANEL	1
PN1286A	PN1286AR2 PRINTED CIRCUIT BOARD	1
V0977	5 POLES AC SOCKET	1
V0978	AC SOCKET CASING	1
V0979	MALE CONTACT	5
Z0021	ROUND BRASS FOR CIRCUIT BREAKER	2

SCH0398AR0 Component layout

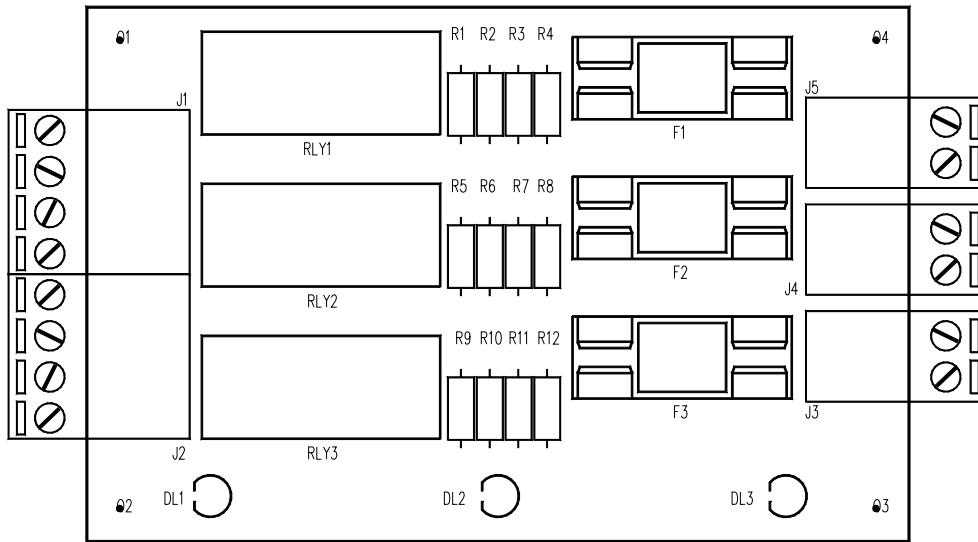

SCH0398AR0 COMPONENT LIST

Part Name/Number	Description	Qty.	Comps.
DL LEDG5 03060	03060 GREEN LED DIODE 5mm	3	DL1-3
FUSE 2A-PCB 7543	7543 5x2 FUSE-HOLDER + FUSE	3	F1-3
J CON KBW02_2P_M_90°	02897 + 02898 ELSAP PCB CONNECTOR	3	J3-5
J CON KBW04_4P_M_90°	02881 + 02882A ELSAP PCB CONNECTOR	2	J1-2
R 100R-1/2W 00139	00139 1/2W 5% RESISTOR	12	R1-12
RL FINDER40.52 756A	7567A RELE	3	RLY1-3

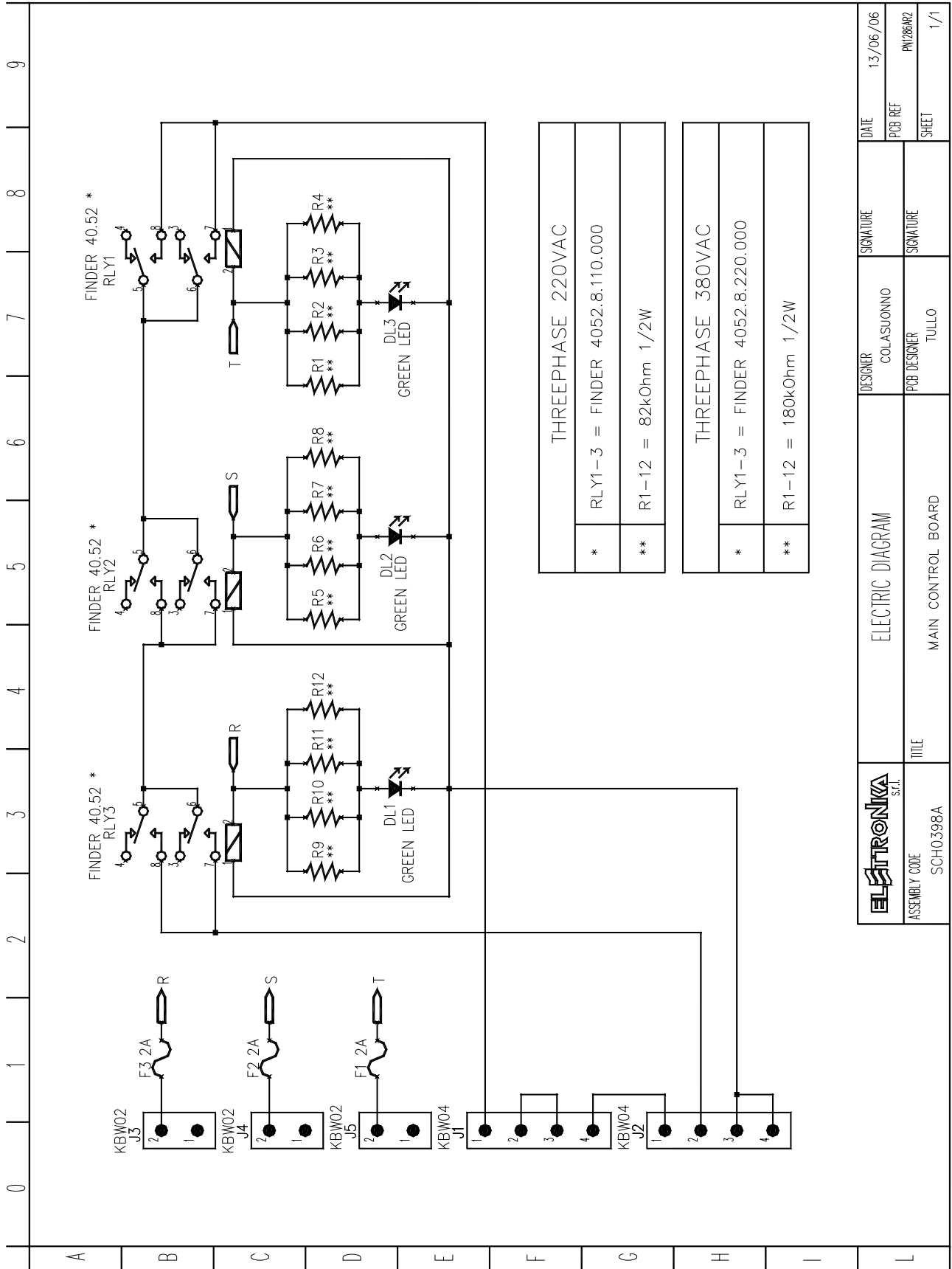

THREEPHASE 220VAC	
*	RLY1-3 = FINDER 4052.8.110.000
**	R1-12 = 82kOhm 1/2W
THREEPHASE 380VAC	
*	RLY1-3 = FINDER 4052.8.220.000
**	R1-12 = 180kOhm 1/2W

	DESIGNER	COLASUONNO	DESIGNER SIGNATURE	DATE	13/06/06
	ASSEMBLY CODE	SCH0398A	PCB DESIGNER	PCB REF	PN1266R2
TITLE			MAIN CONTROL BOARD		SHEET
			TULLO		1/1

SCH0268AR0 Component layout

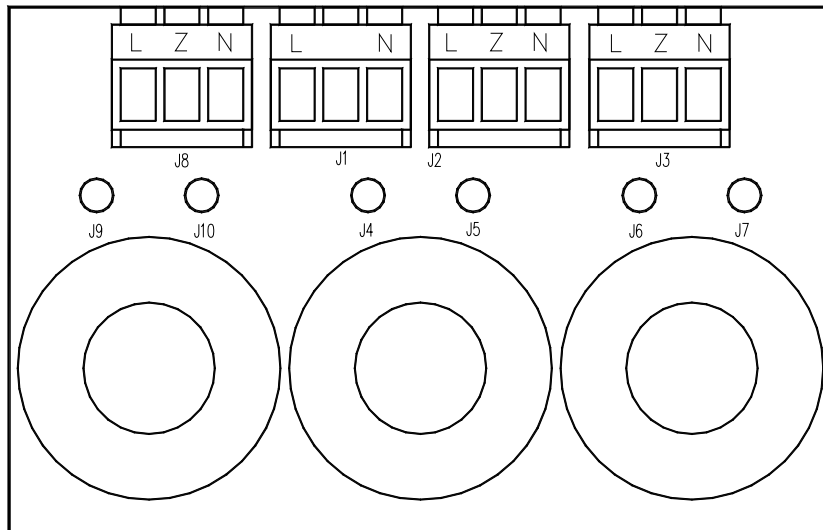

SCH0268AR0 COMPONENT LIST

Part Name/Number	Description	Qty.	Comps.
J CON HD515V/05-3PVE	02893+02894 PAN PCB CONNECTOR	4	J1-3, J8
J TESTP1.3mm 07913	07913 TEST POINT	6	J4-7, J9-10

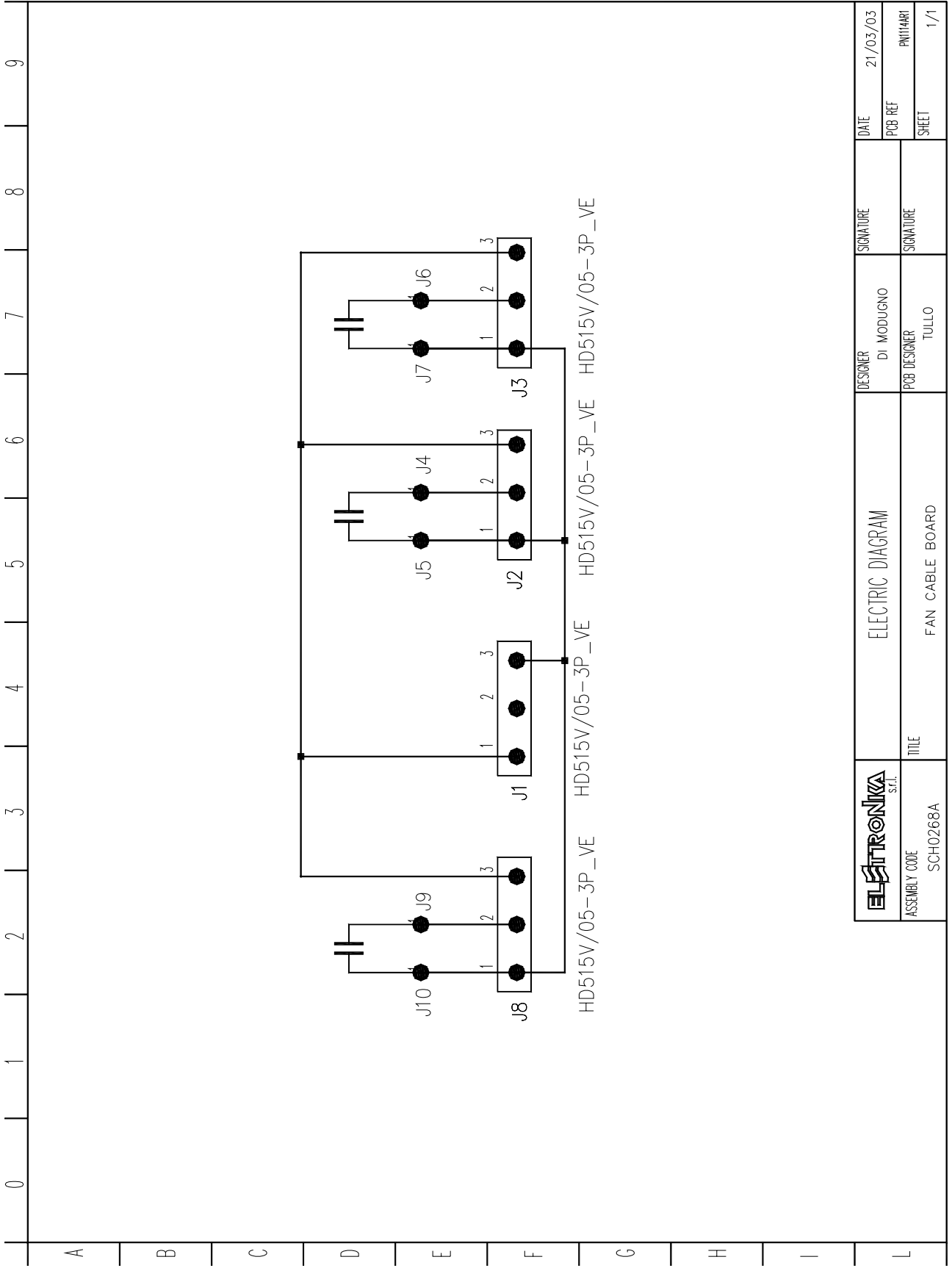

	ELECTRIC DIAGRAM	DESIGNER	DI MODUGNO	SIGNATURE	DATE	21/03/03
		TITLE	FAN CABLE BOARD	PCB DESIGNER	TULLO	PCB REF
ASSEMBLY CODE	SCH0268A				SHEET	1/1

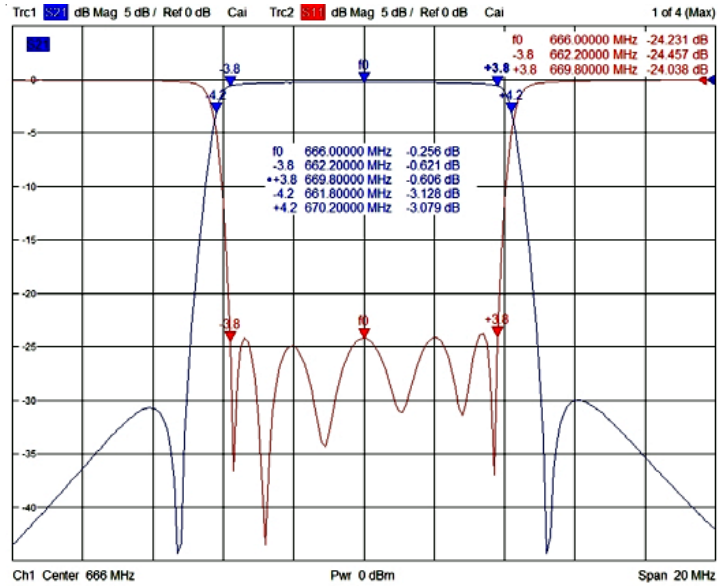

TECHNICAL DATA

Configuration	6 Cavities Elliptical	Attenuation f(0) ±12MHz	≥ 50dB
Max Output Power	1.2kW (rms)	SWR	≤ 1.2
Frequency Range	470 - 860MHz	2 nd Harmonic Attenuation	≥ 80dB
Standards	6 to 8MHz	Group Delay Variation	< 200ns
Insertion Loss f(0)	< 0.4dB	Temperature Stability	≤ 2kHz / K
Attenuation f(0) ±3.8MHz	≤ 1.3dB	Ambiente Temperature Range	-10°C to +50°C
Attenuation f(0) ±4.2MHz	≥ 4.5dB	Weight	20kg
Attenuation f(0) ±6MHz	≥ 30dB	Dimensions	Max 350x360x212mm

OPTIONS

- Output Monitor Connector
- 19" Standard Rack
- Mixed Connectors

0 1 2 3 4 5 6 7 8 9

A

B

C

D

E

F

G

H

I

L

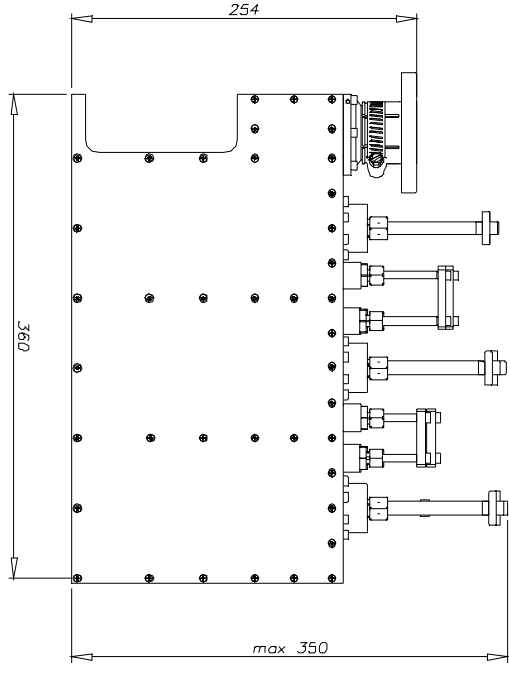
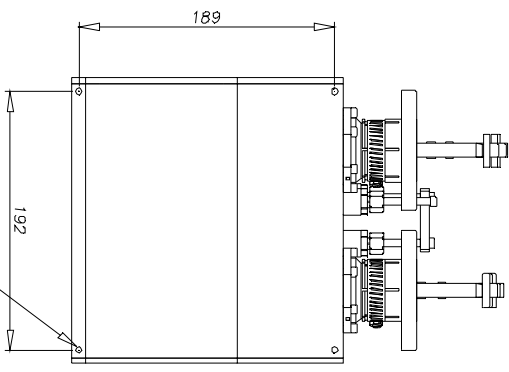
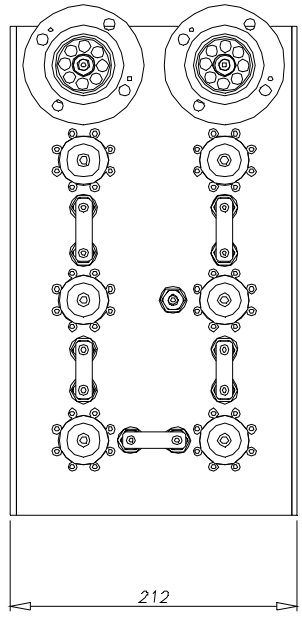

ASSEMBLY CODE
06680B

COMPONENT LAYOUT

TITLE
UHF DTV BANDPASS FILTER

DESIGNER

PCB DESIGNER

SIGNATURE

SIGNATURE

DATE
03/08/09

PCB REF
06680B

SHEET
1/1

This page is intentionally blank

ACCESSORIES



AMPLIFIER CONTROL

User's manual

This page is intentionally blank

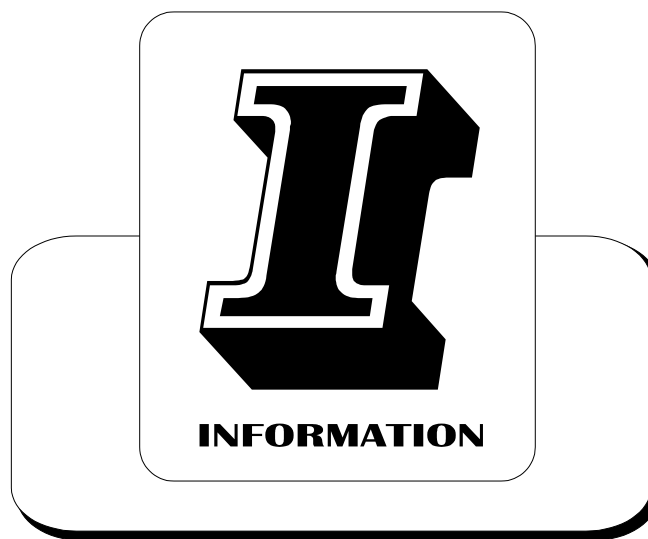

Section 1 - Information

Contents:

- 1.1 Description*
- 1.2 Technical characteristics*
- Front Panel*
- Rear Panel*
- Front and Rear Panel Connectors*
- Block Diagram*

AMPLIFIER CONTROL



1.1 DESCRIPTION

The Amplifier Control (AC) module is the equipment that allows to monitor and manage from a single location a modular transmitter, composed by several combined amplifier modules (AM). The AC continuously monitors the status of the AMs and highlights any anomaly, it monitors the powers in antenna (forward and reflected) and the unbalancing, if any, showing all of the parameters on the display and through the status LEDs. It is possible to power supply the fans of the rack directly by the AC, which constantly monitors their operation, thus protecting the AMs and the other components in the rack in case of failure. Even the exciter(s) can be powered directly by the AC, so that it can be switched on or off along with the amplification stage.

The human-machine interface (HMI), intuitive and user-friendly - most of all thanks to the large graphic display which covers the most of the front panel and to the six status LEDs -, the noise-immune RS485 connection with the AMs, the possibility to connect a series of switches to an Interlock input and the remote control option make the AC a reliable, as well as easy to use, device to be used in low and high-power, FM and TV, analogue and digital, combined and separated transmitters.

In most cases the AC is already installed into the transmitter, wired and calibrated, so that the user can use it without having to worry about technical details. Anyway, Section 2 of this manual covers the main information about installation and external connections. For additional technical information, contact the Customer Service of Elettronika S.r.l. or the local distributor. Section 3 describes the operation of the AC and everything the user can do with it. Read this section carefully before using the device.

1.2 TECHNICAL CHARACTERISTICS

Human-Machine Interface

- 240x128 graphic display with CCFL backlight
- 3 general LEDs (ON, REMOTE, ALARM)
- 3 alarm LEDs for RF powers (FWD, REF, UNB)
- 4 push-buttons (ESC, RET, UP, DOWN)

Alarms resulting in the transmitter being switched off

- Fans rotation (about 10 second delay)
- Interlock (immediate, can be disabled)
- Antenna Reflected power (if configured)

Alarms not resulting in the transmitter being switched off

- Lack of communication with an Amplifier Module
- Amplifier module locally switched off
- Alarm on amplifier module
- Power in antenna or unbalancing beyond the threshold (Reflected power alarm can be configured to switch off the transmitter)

Connections on the front panel

- RF Monitor on 50Ω BNC connector (0dBm at the nominal power)
- RS232 on DCE-type D-SUB9 female connector, for control via PC or firmware update

Connections on rear panel

- RS485 on two D-SUB9 female connectors for the connection with the Amplifier Modules
- RS485 on D-SUB9 female connector for the connection with an optional remote control device*
- Telemeasures (Forward power, Reflected power, Unbalancing, Alarm) and telecontrol (ON/OFF) on D-SUB25 female connector
- Up to 8 RF powers can be monitored on BNC connectors
- Fans rotation control on BNC connector
- Alarm on the opening of a series of switches (Interlock) on BNC connector
- Power supply +24Vdc available on two 2-poles connectors

Miscellaneous

- Real-time clock with CR2032 lithium backup battery (nominal voltage 3V, nominal capacity 210mAh)
- Alarm and event list up to 130 entries
- 100-240Vac 50/60Hz Power Supply
- 19"-3U Cabinet, deep 260mm
- 6kg Weight
- Operating Temperature -5° to +45°C
- Relative Humidity 20% - 90%
- Altitude up to 2500m

* For more information contact the Sales Department of Elettronika S.r.l. or the local distributor.
Specifications and characteristics are subject to change without notice.

Front panel

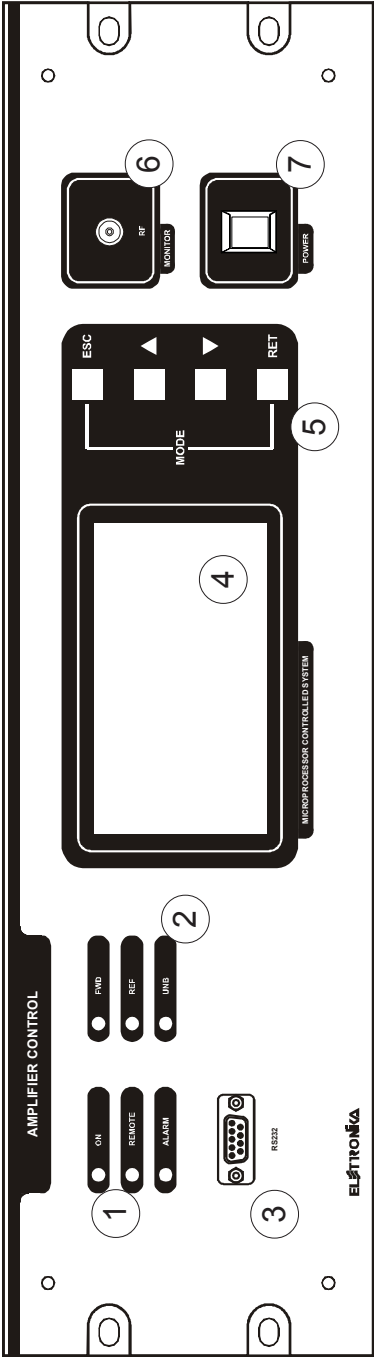

DESCRIPTION

1	Status LEDs
2	Alarm LEDs
3	RS232 Socket
4	LCD Display
5	Function Keys
6	RF Monitor Connector
7	Main Switch

Rear panel

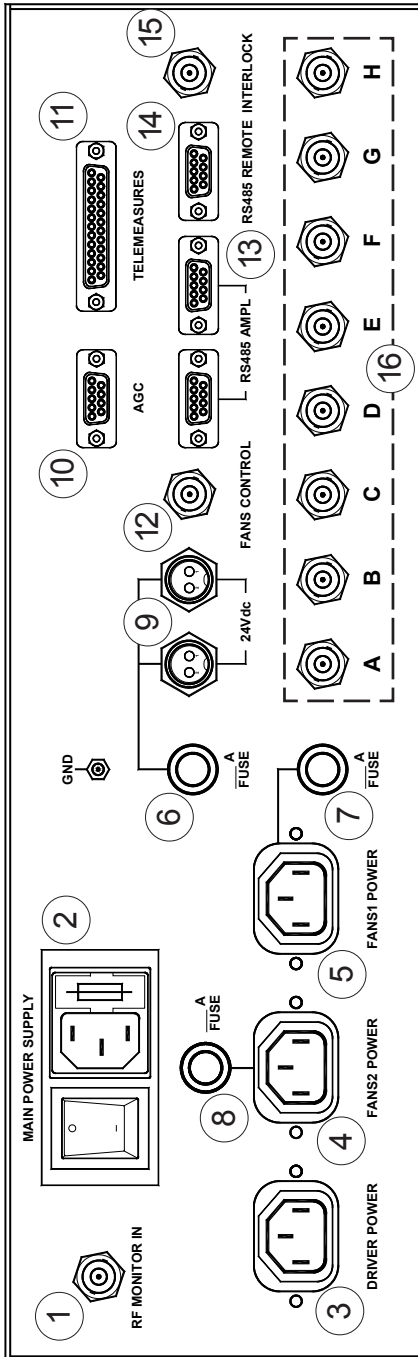

DESCRIPTION	
1	RF Monitor Input Connector
2	Main Power Supply Socket with Fuse (10A)
3	Driver1 Power Supply Socket
4	Driver2 Power Supply Socket
5	Fans Power Supply Socket
6	1A Fuse (+24Vdc)
7	Fuse (Fans: the value may change)
8	Fuse (Fans: the value may change)*
9	+24Vdc Connector
10	AGC Socket
11	Telemetry Socket
12	Fans Control Connector
13	RS485 Amplifiers Socket
14	RS485 Remote Control Socket
15	Interlock Connector
16	Power Measurement Connector

* Present only in two racks transmitter

Front and rear panel connectors

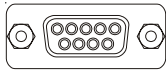

RS232 (on front panel)

Pin 2: RS232 TX Pin 5: GND
Pin 3: RS232 RX

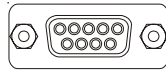

Remote RS485 for RCU connection
(on rear panel)

Pin 2: RS485 RX- Pin 7: RS485 TX-
Pin 3: RS485 RX+ Pin 8: RS485 TX+
Pin 5: GND

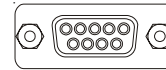

RS485 Amplifiers
(on rear panel)

Pin 2: RS485 TX- Pin 7: RS485 RX-
Pin 3: RS485 TX+ Pin 8: RS485 RX+
Pin 5: GND

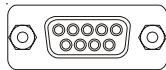

AGC (on rear panel)

Pin 1: GND
Pin 2: AGC Alarm TTL Output
GND=AGC Alarm
+5V=no AGC Alarm
Pin 3: AGC Alarm TTL Output
GND=AGC Alarm
+5V=no AGC Alarm
Pin 8: Forward Power
Analog Output (0V - 5V)
Pin 9: Forward Power
Analog Output (0V - 5V)

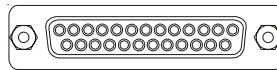

Telemeasures (on rear panel)

Pin 1: Remote ON/OFF TTL Input
GND=Remote ON
+5V or float=Remote OFF
Pin 6: Alarm TTL Output
GND=Alarm
+5V=no Alarm
Pin 7: RMS/PEAK Power TTL Input
GND=RMS
+5V or float=PEAK
Pin 8: GND
Pin 9: GND
Pin 14: Remote Amplifier ON/OFF TTL Input
if Remote ON then
GND=Amplifier OFF
+5V or float=Amplifier ON
Pin 19: Alarm TTL Output
GND=Alarm
+5V=no Alarm
Pin 20: GND
Pin 21: +5V
Pin 22: Forward Power
Analog Output (0V - 5V)
Pin 23: Reflected Power
Analog Output (0V - 5V)
Pin 24: Unbalance Power
Analog Output (0V - 5V)



Fans Control (on rear panel)

Contact: Fans Control Switch
TTL or Free contact Input
Closed/GND=no Fans Alarm
Open/+5V=Fans Alarm
Body: GND



+24Vdc Output (on rear panel)

Pin 1: GND Pin 2: +24Vdc Out
(for Dummy Load)

Block diagram

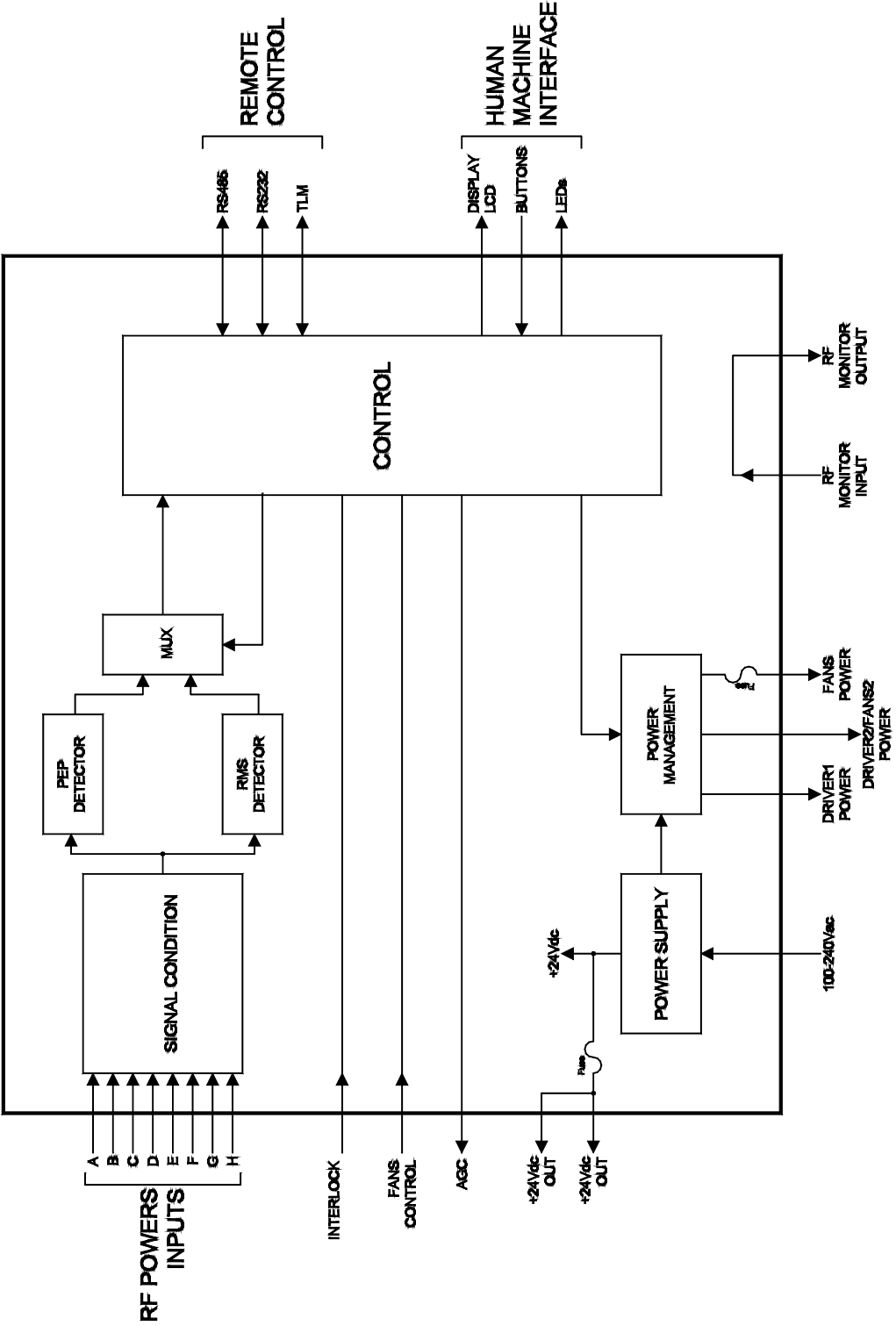

This page is intentionally blank

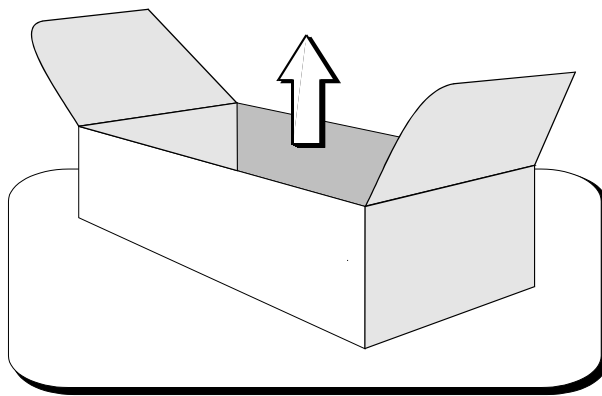

Section 2 - Installation

Contents:

- 2.1 Preliminary operations*
- 2.2 Operating environment*
- 2.3 First installation*
- 2.4 Connection with a Remote Control System*

2.1 PRELIMINARY OPERATIONS

No wiring is necessary because the device is already installed and correctly connected to the power supply and other parts of the transmitter. In case a new AC has to be installed, check all connections with the help of the diagrams and tables in this Section. Correct installation of the equipment is important for maximum performance and reliability. Before switching on and powering the transmitter, make sure that all connections are correctly made.

The pinout tables of multi-pin connectors can be found in the Front and Rear Panel in the previous Section.

2.2 OPERATING ENVIRONMENT

The equipment can be installed into a standard component rack or on a suitable surface such as a bench or a desk. In any case, the area should be as clean and well-ventilated as possible. Always allow for at least 2cm of clearance under the unit for ventilation. If the device is set on a flat surface, install spacers on the bottom cover plate. If it is installed in a rack, provide adequate clearance above and below. Do not locate the device directly above a heat source.

2.3 FIRST INSTALLATION

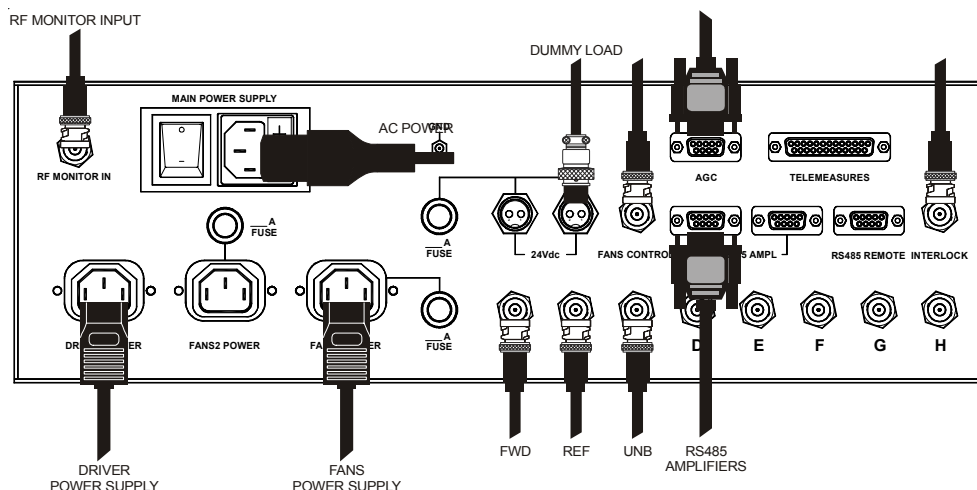

Main Power Supply

Before connecting the power supply cable, make sure that two 10A fuses have been put inside the socket. To open it, use a little screwdriver to move the plastic table. Then connect the power supply cable. To switch on the amplifier control, move the switch next to the power supply connector to position 1.

DRIVER1/2 Power Supply

The transmitter can be wired so that the exciters are directly fed by the AC. The advantage of this configuration is the possibility to control the whole transmitter, Amplifier Modules and drivers, from a single point, that is the AC. Using the adequate male-female cord, connect the power supply of the driver to DRIVER1 POWER connector, for combined transmitters; connect the power supply of the drivers to DRIVER1 POWER and DRIVER2 POWER connector, for TV separated transmitter.

FANS Power Supply

The rack in which the transmitter is installed is usually provided with cooling fans. These can be fed directly by the AC in the same way as the drivers, so that they are automatically switched on and off along with the AMs. To do this, connect the fans to the FANS POWER connector using the proper cord. The power supply is limited by a fuse on the rear panel. The blowing current of this fuse depends on the kind of fans in use.

FANS CONTROL

A failure of fans may cause the temperature of the rack to rise beyond acceptable limits, with dangerous consequences on the most critical parts of the AMs. For this reason, the AC continuously monitor the rotation of the fan, if it is powered, by analysing the input signal at the FANS CONTROL BNC connector. If the fans are rotating, the two poles of the BNC connector should be shorted.

INTERLOCK

The Interlock connector may be used as an additional alarm source stopping the transmitter operation. Usually it is connected to the frame of the rack and activated when it is open, in order to prevent the operators to touch dangerous electrical parts during maintenance operations. It is possible to connect a series of switches between the two poles of the BNC Interlock connector: during normal operations all switches are closed, if any of them is open, the AC detects the absence of continuity between the two poles of the INTERLOCK connector and immediately stops the transmitter. Anyhow, this behaviour can be disabled from the display.

RF Powers (A-H)

During the normal operation of the transmitter, the AC measures the RF powers in antenna (forward and reflected) and the unbalancing, if any, at the combiners. A maximum of 8 inputs is possible, even though usually only 3 of them are used (1 forward power, 1 reflected power, 1 combiner unbalancing). That depends on the kind of transmitter. Usually channel A is used for forward power, channel B for reflected power, channel C for the unbalancing.

AGC

In some transmitters it is possible to implement the AGC (Automatic Gain Control) functionality, which allows to keep the power output in antenna constant in spite of any factor which may make it changes, such as temperature. To implement the AGC functionality correctly, the exciter (or exciters for dual driver transmitters) has to be connected to the AC using the cable provided.

When this connection is present and the AGC is enabled on the exciter, the latter can read the power in

antenna and keep it constant over time, by increasing or decreasing the internal gain. In case of faults in the high-power amplifier stage, the AC stops the AGC in order to prevent any possible damage.

AMPL RS485

In a high-power transmitter there are a number of Amplifier Modules (AM) which RF outputs are combined in order to provide the required total high power. Although these are separated devices, it is necessary to be able to control all of them from a single point of the transmitter, and even switch them on and off at the same time. This point is represented by the AC, which is in constant communication with all AMs through an RS485 serial bus, immune from electromagnetic noise inside the rack of the transmitter. All AMs have to be connected to the AC by using the proper multi-connector cable to one of the two AMPL RS485 connectors.

+24Vdc

On the rear panel there are two two-poles connectors on which a +24V DC power supply is always available, protected by a 1A fuse. It is usually used to power supply Dummy Loads in the rack.

RF Monitor

On the front panel of the AC there is a monitor of the RF signal in antenna on a 50Ω BNC connector. The technical staff of Elettronika provides for the correct calibration of this monitor, taking into consideration the coupling of the directional coupler and all cable losses, if any. At the nominal power of the transmitter, the signal level at the RF monitor is 0dBm level.

2.4 CONNECTION WITH A REMOTE CONTROL SYSTEM

The AC can be controlled locally by the display and buttons or remotely by using one of the following three systems: RS485, Telemeasures or RS232 (only one at a time).

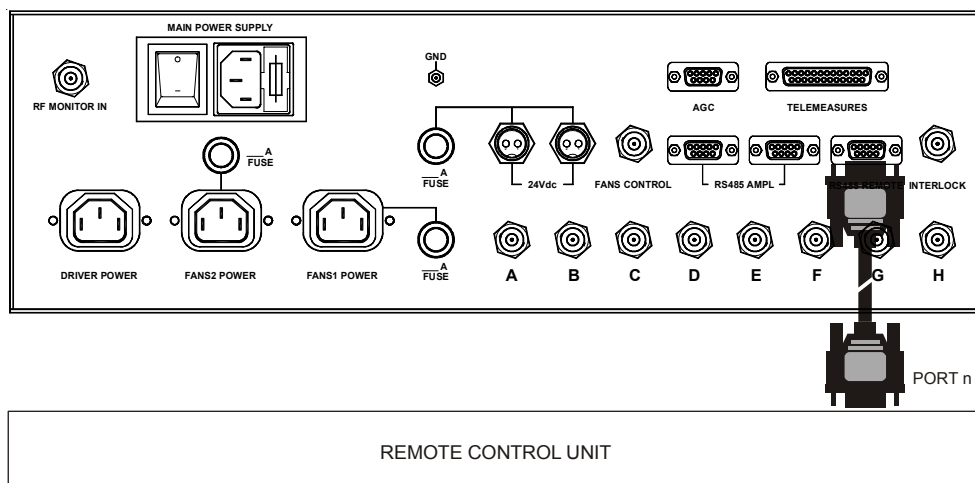

RS232

On the front panel of the AC there is a D-SUB9 female connector used to control the transmitter from a PC, using a standard RS232 serial connection. For more information about remote control option, contact the Sales Department of Elettronika S.r.l. or the local distributor.

The pin-out of this connector is DCE-type and can be connected to a PC using a direct cable.

This connector can also be used to update the firmware of the AC. This operation should only be performed by qualified technicians.

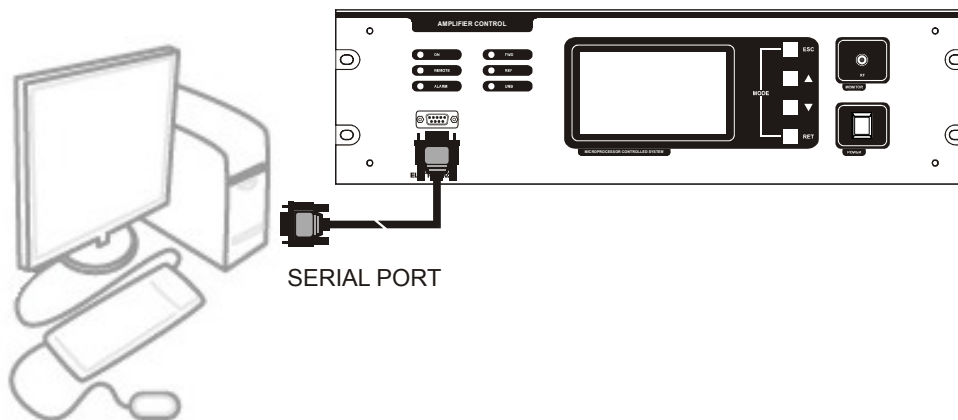

RS485

On the rear panel there is a D-SUB9 female connector used for remote control via RS485. The RCU device manufactured by Elettronika S.r.l. is needed for this feature to be used. For more information, contact the Sales Department of Elettronika S.r.l. or the local distributor.

Telemeasures

The D-SUB25 female connector allows to control the transmitter remotely using a generic control interface. Some analogue and digital outputs are available on this connector, thanks to which a control system can read the status of the transmitter. There are also some inputs allowing to switch the transmitter on and off from remote by opening or closing some contacts.

It is possible to connect two switches to close pin 1 and pin 14 to GND. Usually the switch on pin 1 is open in order to disable remote control. To switch the transmitter on/off, close/open the switch on pin 14 depending on the command to be given, then close the switch on pin 1 to send the command. Once it has been received by the AC, the switch on pin 1 can be open again. For better comprehension see the figure below, showing the closed switch with a low level and the open one with a high level.

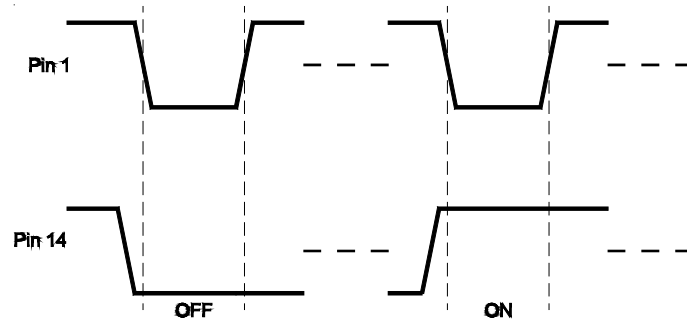

Switching on and off the transmitter by means of two switches on pins 1 and 14 of the telemeasures connector

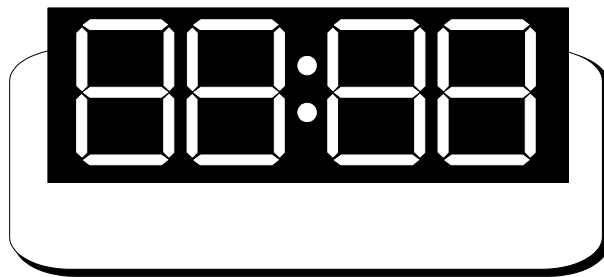

Section 3 - Operations

Contents:

- 3.1 Switching On the Amplifier Control*
- 3.2 Operation*
- 3.3 Menu*

3.1 SWITCHING ON THE AMPLIFIER CONTROL

After having made sure of the wiring, the transmitter can be switched on by using the mains switch on the rear panel. The very first time the transmitter is switched on, set the POWER button on the front panel to 0, which means transmitter off. The display will show for a few seconds an introduction animation, displaying the kind of transmitter and the firmware version. During this stage, all LEDs light up and the buzzer sounds in order to check that it works. Since both LEDs and buzzer are used to signal failures, it is important to check them periodically. Check the paragraph dedicated to the display, later in this manual, in case it should be hard or impossible to read.

3.2 OPERATION

The Amplifier Control (AC) is the central point of the whole transmitter. It allows to switch on and off all of the amplifier modules (AM), the exciters and the fans, it monitors alarms and anomalies and automatically applies any precaution needed, it manages the user interface by means of the display, LEDs and buttons and answers to local or remote commands by the user.

There are two main operating statuses of the transmitter, ON and OFF, both described in detail below.

OFF Status

In the OFF status the output power in antenna is zero. To switch off the transmitter locally, just set the POWER button on the front panel to 0. The ON LED is switched off as well. While the POWER button is set to 1, it is still possible to switch off the transmitter from remote, if this function is enabled, through the RS232/RS485 serial connections or the TELEMEASURE connector. In this case the ON LED starts blinking.

In OFF status, the AC stops feeding the fans and the exciters, switching them off, and also puts in stand-by all of the AMs. While in OFF status the AC keeps communicating with the AMs, polling their data and showing them on the display. Usually, in this situation, most of these parameters are null.

ON Status

The ON status indicates the normal operation of the transmitter, which is switched on and is sending power to the antenna. To activate this status, just set the POWER button on the front panel to 1, or use the remote RS232/RS485 serial connection or the TELEMEASURE connector. It is possible to switch on the transmitter from remote only if this function has been enabled and the POWER button is on position 1. While in ON status, the ON LED is lit. When changing to ON status, the AC feeds the exciters and the fans and switches on all of the AMs. While in this status it polls all data from the AMs and shows them on the display. It also monitors the status of the fans, the Interlock and the RF powers.

Interlock

In case of Interlock alarm, if it is enabled, the AC immediately switches off the transmitter (AMs, fans and

exciters). If the alarm ends, the transmitter is automatically switched on again.

Fan Control

In case of fan alarm, that is when the FANS CONTROL shows that they are not working properly, the AC switches off the AMs and exciter(s) after a few seconds, but keeps the fans on, unlike the Interlock alarm. If the alarm was due to a temporary block or failure and the fans restarts working, the AC automatically switches on the AMs and exciter(s) again.

RF Powers

The AC continuously monitors the value of the RF powers in antenna and of the unbalancing, and shows them on the display. Each power has a maximum threshold which is set in factory depending on the type of transmitter. If any of this power goes beyond this threshold, the AC indicates an alarm condition by means of the LEDs and buzzer, and by blinking the indication of the power on the display.

The transmitter is not switched off in this case, because the AMs are protected against excessive power values. It is possible to enable the REF protection that causes the switching off when the reflected power in antenna is too high.

LEDs

On the front panel there are six status LEDs which allow a visual verification of the status of the transmitter. The three LEDs on the left (ON, REMOTE and ALARM) are general ones; the three on the right (FWD, REF and UNB) refer to the alarms concerning RF powers. Table below shows the meaning of each LED.

LED	COLOUR	OFF	ON	BLINKING
ON	Green	Transmitter Off	Transmitter On	Transmitter Off by remote
REMOTE	Yellow	Remote control disabled	Remote control enabled	-
ALARM	Red	No alarm present	Alarm present	Alarm ended
FWD	Red	Forward power under the threshold	-	Forward power beyond the threshold
REF	Red	Reflected power under the threshold	-	Reflected power beyond the threshold
UNB	Red	All of Unbalancing under the threshold	-	One of Unbalancing beyond the threshold

3.3 MENU

During normal operation, all information gathered by the AC (RF powers, parameters of the AMs, temperature, date, time, etc) are displayed on a large 240x128 graphic display provided with backlight. If this display is

hard to read, the contrast can be adjusted by acting with a small screwdriver into the hole on the frontal panel marked with the  symbol.

The main screen is similar to the one in figure below. It may change depending on the transmitter, for instance depending on the number of AMs and unbalancing.

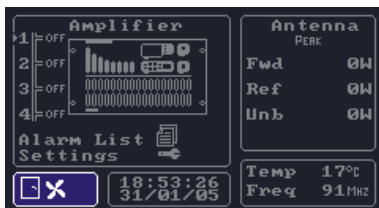

Alarm Window

The alarm window may contain three icons indicating anomalies in the operation of the transmitter.

The first icon on the left represents the status of the Interlock. If there is no Interlock alarm, thus the switches chain is closed, the icon is a closed door. In case of Interlock alarm, it is a blinking open door. In case the Interlock is disabled, the icon will not be displayed at all.

The second icon, in the middle, refers to the status of the transmitter fans and can be a still fan (fans aren't rotating) or a moving one (fans are rotating). It is important to note that this icon represents the status of the FANS CONTROL contact located on the rear panel, which indicates the actual work (rotation) of the fans rather than the fact that they are powered or not. In other words, it is possible that the fans are powered but, for some anomaly, are not working correctly. In this case the icon is a still fan blinking.

The third icon, on the right, indicates a generic alarm. It is not displayed if the AC is not detecting any malfunctioning condition, while it is displayed as a bell in case of any alarm condition. If the alarm condition ends, the bell blinks to indicate that something happened previously. It stops blinking if the alarms list (Log) is accessed to check the occurred events.



Date and time window

The AC is provided with an internal clock with a backup battery placed on the display board. The date is used to associate each event in the log to the exact time at which it occurred. The time can be set from the Settings menu. The AC synchronizes all of the AMs so that all of them display the same time.



Temperature and frequency window

The temperature shown on the display of the AC is the internal temperature of the device and can be considered as a good estimation of the temperature inside the rack. The indication of the frequency is only present for some transmitters, and allows to keep into consideration the different gains of directional couplers with frequency. It can be set from the Settings menu.



RF powers window

This window shows the measures of the RF powers in antenna and the unbalancing of the combiners, if any. The number of monitored powers, especially unbalancing, changes depending on the transmitter. Each power has an alarm upper threshold, beyond which the relevant indication starts blinking. This window also shows the kind of measures, which can be either average quadratic power (RMS, usually used for digital transmitters) or peak envelopment power (PEP, usually used in analogue transmitters).



Main window

The main window contains the picture and a list of the AMs, numbered in series starting from 1. Next to each number of the list, the ON/OFF status of the module is displayed. If any anomaly prevent the correct communication between the AC and a module, the relevant number would blink and no status indication would appear.

The arrow buttons allow to move the cursor onto any of the AMs of the transmitters and on the menu entries Alarm List and Settings.

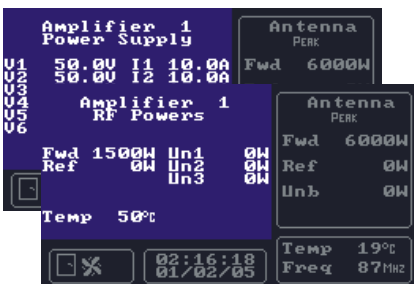

Pressing the RET button while the cursor is on an AM, all of the monitored parameters of that module are displayed. Each amplifier has two associated screens called RF Powers and Power Supply: the first shows the RF powers and the temperature of the amplifier; the second contains the parameters of the power supply (voltages and currents). Note that if the module doesn't communicate correctly with AC, all of the fields are blank. To go to the next or previous screen press arrow buttons. Press ESC to return to the main menu.

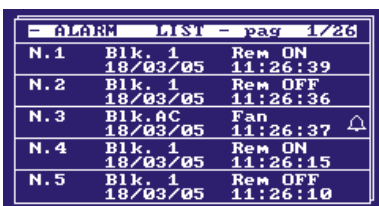

Alarm list

By pressing the RET button on the Alarm List entry in the main window, the whole display shows the event list (log) of the transmitter. Each page of this list contains 5 events sorted in reversed chronological order (the most recent event is the first in the list), and a maximum of 26 pages are available

(130 events). If the list is full and a new event occurs, the oldest event in the list is deleted to make free space to the new one.

Each event has an associated number and contains date and time, concerned module and description of the event. If the event refers to an alarm condition, a bell icon is displayed on the right. The pages of the list can be scrolled using the arrow buttons. Press ESC to return to the main window. To delete all events in the log, press the ESC and RET buttons at the same time. Make sure to check all events of the log before clearing it.

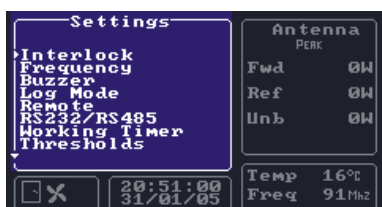

Settings

The settings window allows to set some of the operating parameters of the AC. It only covers a portion of the display area, so that the user can keep the alarm and RF powers window under control.

The Settings menu is composed by a series of parameters which can be displayed and/or changed. Use the arrow buttons to select a parameter and press the RET key to open the relevant screen. The display only shows 8 items at any given time: press the DOWN button while the cursor is on the last displayed item to scroll the menu and show the next one. The UP button works in the same way if used on the first displayed item of the list. Press the ESC key to return to the main window. Note that the items displayed may vary depending on the transmitter and the AC version.

If the selected parameter can be modified, use the arrow buttons to change its value and the RET one to confirm the change. It is possible to cancel the change and restore the original value by pressing the ESC button. If the parameter cannot be modified, it is possible to press ESC to return to the Settings menu. All the settings of the menu are described below.



Interlock

The AC monitors continuously the status of the Interlock and switches off the transmitter in case of alarm, until it ends. This function may be disabled by the Interlock setting menu.

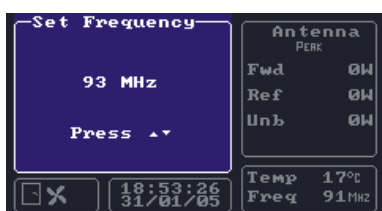

Frequency *(only for some transmitters)*

In some transmitter the AC keeps into consideration the different coupling effect of the directional coupler, used to measure the RF powers, compared to the variation of the frequency. This screen allows to change the frequency of the antenna signal, setting the frequency of the video carrier in case of analogue TV transmitters or the middle band frequency in case of digital or FM transmitters.

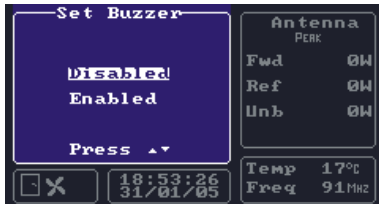

Buzzer

The AC uses the buzzer in case of malfunctioning or situations in which the attention of the user is required. During tests or maintenance it may be useful to disable the buzzer using this menu.

Generally speaking, it is better to reactivate it during the normal operation of the transmitter.



Log Mode

The log is a very important feature as it allows the user to know the details of the alarms and events occurred to the transmitter, even if it is unattended. It has two modes between which the user may choose. The “Alarms & Events” mode logs all alarm conditions as well as events such as the local or remote on/off status changes.

The “Only alarms” mode only logs alarm conditions. It is generally better to use the Alarms & Events mode, because the log has a higher level of detail. The “Only alarms” mode should only be used for testing and maintenance operations, in order to prevent the log to be filled by events of minor importance.



Remote

Using the RS232 connection on the front panel or the RS485 one on the rear panel, the AC may be completely controlled from remote, using a dedicated software. This function may be disabled from the Remote settings menu. If the remote control is disabled, the parameters of the transmitter can still be remotely read, but not changed. The REMOTE LED on the front panel is lit when remote control is enabled, and unlit otherwise.

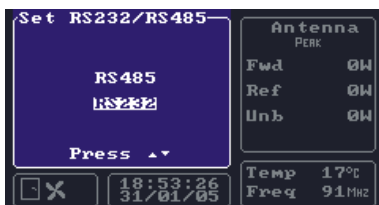

RS232/RS485

The transmitter can be remotely controlled through the RS232 connection on the front panel or the RS485 one on the rear panel. It is not possible to use both connections at the same time, and the desired one must be chosen from this menu.

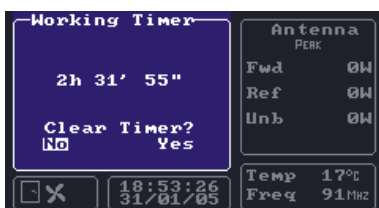

Working Timer

The Working Timer counts the seconds in which the transmitter has been working, i.e. switched on and powered. This screen also allows to reset the Timer.

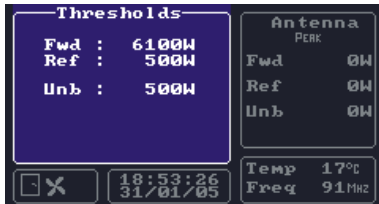

Thresholds

Each RF power monitored by the AC should be below a given maximum threshold. In case a value is beyond the threshold, the AC indicates an alarm condition. The values of the thresholds are displayed in the Thresholds menu.

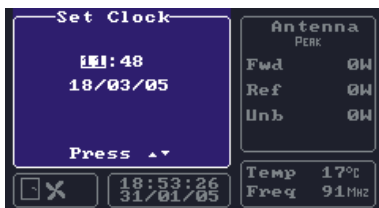

Clock/Date

This menu is used to set the current date and time. Once the changes are confirmed by pressing the RET button, the AC synchronizes all of the AMs of the transmitter.



Backlight

The display is provided with a backlight. A Screensaver may be enabled to make the lamp last longer. When it is, the light is automatically switched off after 8 minutes without any button being pressed, and it is switched on again as soon as any button is pressed.

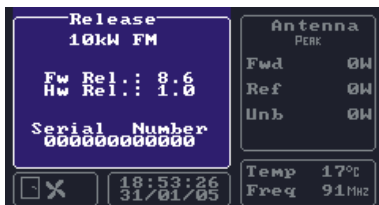

Release

The Release menu shows the kind of the transmitter, the version of the AC firmware and the serial number of the equipment.



Rms/Peak

The Amplifier Control can detect Peak and RMS RF powers. The Peak power is used in analog transmitter (FM or TV), the RMS power is used in digital transmitter.

The user can choose the power detection mode by using the RMS/Peak menu. In dual-mode (analog and digital) transmitter, the switch between RMS and Peak power detection can be linked to an external input signal on TELEMEASURES port (see Rear Panel paragraph for more information). Select TLC item in the RMS/PEAK menu to enable this feature.

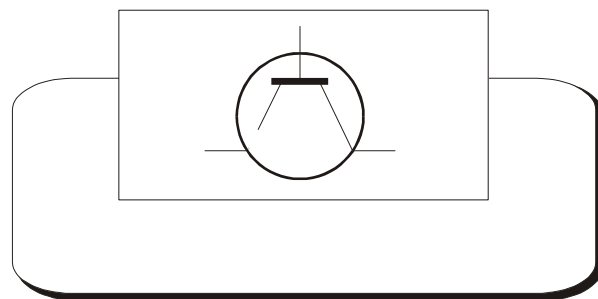

Section 4 - Diagram

Contents:

- APG012C AMPLIFIER CONTROL Cable Diagram*
- APG012C AMPLIFIER CONTROL Component list*
- Modules description*

9
8
7
6
5
4
3
2
1
0

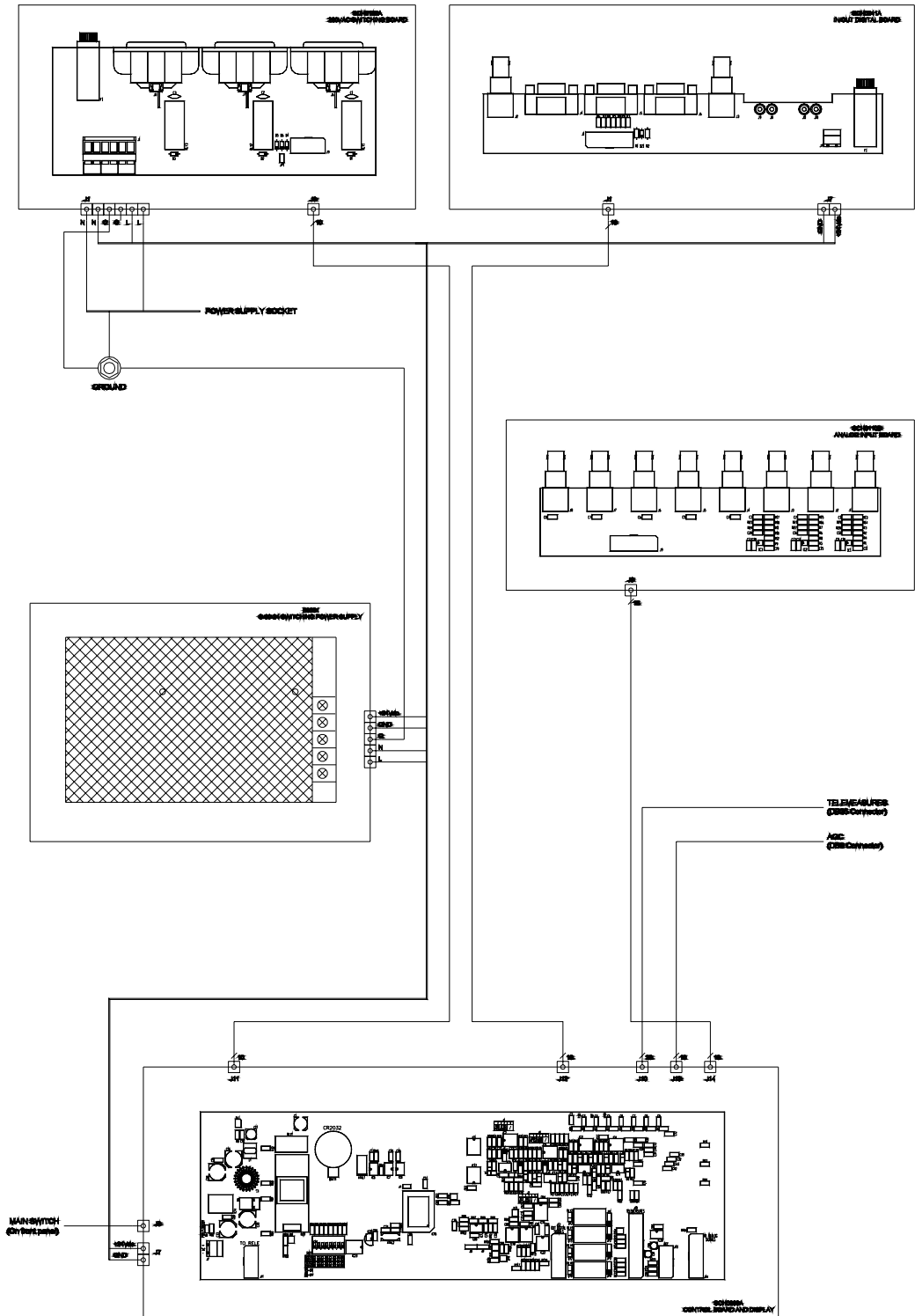

A B C D E F G H I L

 ASSEMBLY CODE APG012C	TITLE AMPLIFIER CONTROL	DESIGNER MODUGNO	SIGNATURE	DATE 19/06/07
	PCB DESIGNER TULLO	SIGNATURE	PCB REF APG012C	SHEET 1/1

Component list**APG012C - AMPLIFIER CONTROL**

Elettronika Code	Description	Qty
02018	BNC CONNECTOR FOR RG174 CABLE	1
02035	BNC CONNECTOR FOR RG316 CABLE	1
02695	DB9 CONNECTOR FOR IU008059 CABLE	1
02699	10 WIRE FEMALE CONNECTOR	3
02700	16 WIRE FEMALE CONNECTOR	4
02740	FEMALE PAN	1
02741	COVER PAN	1
02843	2 POLES SHIELDED SOCKET	2
02855	26 WIRE FEMALE CONNECTOR	1
02856	DB25 FEMALE CONNECTOR	1
02880	10A GREEN SOCKET	1
05504	MECHANICAL DETAIL	1
05525	MECHANICAL DETAIL	2
07524A	SWITCH	1
07925	PVC PROTECTION	1
07926	PVC PROTECTION	1
08500	RG174 50Ω CABLE	0.30
C0814	SHIELDED COPPER ADHESIVE	0.50
CON0145	CON0145R1 BOX	1
CON0153	CON0153AR0 MECHANICAL DETAIL	1
DET0313	DET0313R0 3-4U HANDLES	2
E0031	S-60-24 SWITCHING POWER SUPPLY	1
PAN0066	PAN0066AR0 FRONT PANEL	1
SCH0110BR0	ANALOG INPUT BOARD	1
SCH0152AR0	220VAC SWITCHING BOARD	1
SCH0239AR0	CONTROL BOARD AND DISPLAY	1
SCH0241AR0	IN/OUT DIGITAL BOARD	1
V0761	BLACK PLASTIC TAP	6

This page is intentionally blank

DESCRIPTION

SCH0239A is the Main Board of the Amplifier Control. It could be considered the core of the equipment. This board is based on a powerful 16 bit microcontroller that runs an optimized ad-hoc firmware for the transmitter. The firmware can be simply upgraded by means of RS232 (see the paragraph below for more details). On the board a small DC/DC power supply is present that converts the +24Vdc input signal to +5Vdc output signal used for almost all the integrated circuits.

The microcontroller gathers all the informations from AMs (by RS485 bus), antenna directional coupler, interlock chain, fans and so on. It makes these informations available on the local interface (display and leds) and remote (RS232, RS485 and TLM).

The analog inputs are conditioned in order to make a good monitoring of the RF powers, RMS and PEP type. The input gain is variable by a trimmer and should be calibrated as explained below. The internal A/D converter of the microcontroller makes the sampling and converts these signals into digital.

The LCD has a CCFL backlight that is fed by the inverter INV1 (see the component layout of the board).

All the other boards inside the AC are connected to the display board.

- Dip-switches

On the display board two series of dip-switches are present (*see SW1 and SW2 on the component layout*). Switches on SW1 is not used. Switches on SW2 must be set in the following way:

1	Not Used
2	Not Used
3	Not Used
4	OFF
5	OFF
6	ON
7	ON
8	ON

FIRMWARE UPDATE

The microcontroller is provided with a built-in Flash memory containing the firmware. The firmware can be updated with a later version without removing the apparatus from the rack and/or replacing the chip.

To upgrade it, connect a PC to the RS232 socket on the front panel of the apparatus by means of a cable

DB9 male - DB9 female (pin-to-pin).

Launch on the PC the EKAFlash application, select the serial port in use on the PC, choose the update file by pressing the “...” key and click on Download button.

Eventually, turn off the AC from the main switch and then turn it on again. The upgrade of the firmware begins on the EKAFlash window. The figure below shows this window while a firmware is being updated.

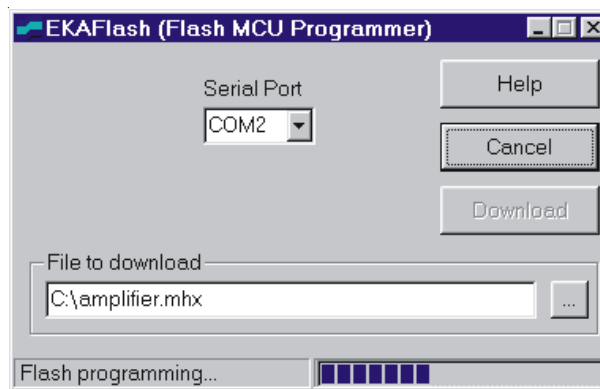

The EKAFlash window while updating a firmware

POWER CALIBRATION

FWD Power calibration

Disconnect the antenna and connect a wattmeter to the antenna connector. Give power to the amplifier until you will read on the wattmeter a value corresponding to the equipment nominal power. Then turn the trimmer *A* (see *Bottom Component layout*), it is a variable resistor used to adjust the A analog input measure until you read approximately the same FWD power value on the display.

REF Power calibration

Disconnect the antenna and connect a wattmeter to the antenna connector. Connect the Forward power monitoring cable to the Reflected power input connector. Give power to the amplifier until you will read on the wattmeter a value corresponding to 10% of the equipment nominal power. Then turn the trimmer *B* (see *Bottom Component layout*), it is a variable resistor used to adjust the B analog input measure until you read approximately the same REF power value on the display.

UNB Calibration

Connect a wattmeter before the dummy load. Give power to the amplifier then turn off one slave module: you will read an amount of unbalancing power on the wattmeter. Turn the trimmer *C* (see *Bottom Component layout*), it is a variable resistor used to adjust the C analog input measure until you read approximately the same UNB power value on the display.

SCH0239AR0 Top layer Component layout

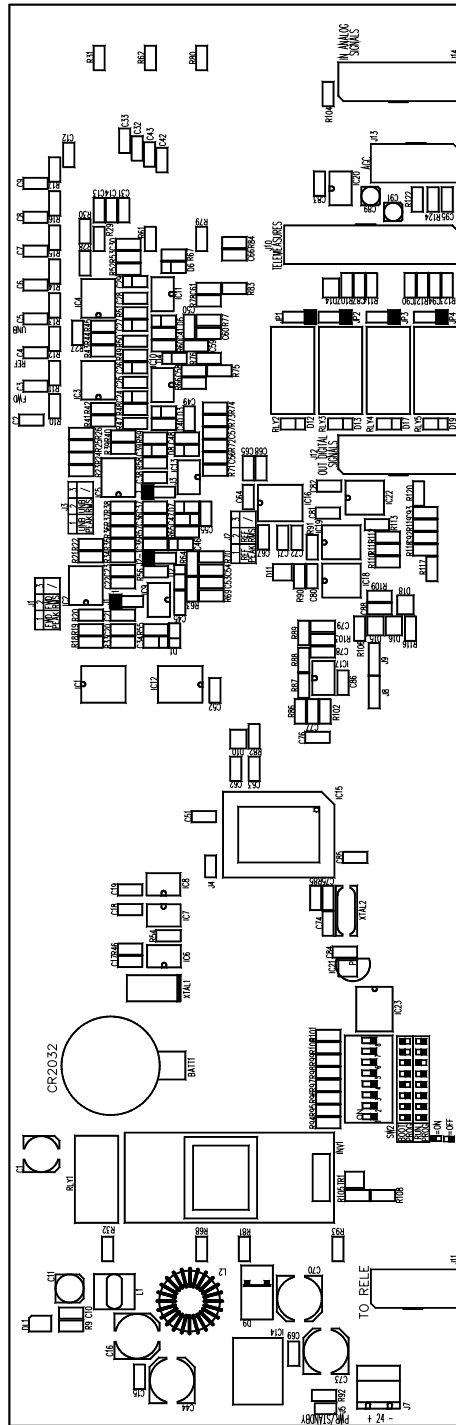

SCH0239AR0 Bottom layer Component layout

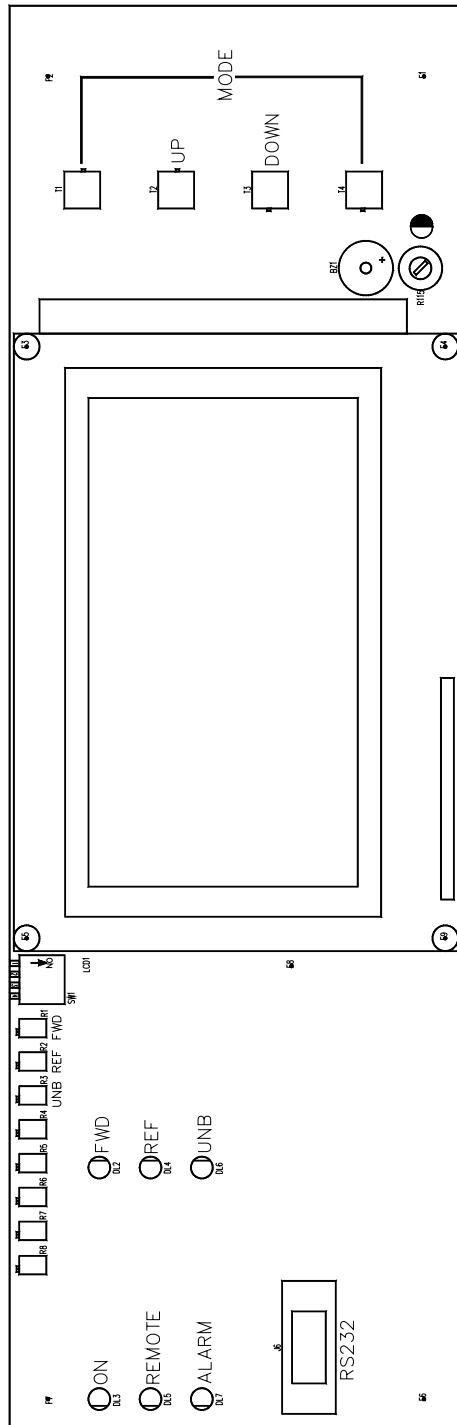

SCH0239AR0 COMPONENT LIST

Part Name/Number	Description	Qty.	Comps.	Page 1/2
BATT BH001RB 3093_90	03093 03090 BATTERY HOLDER	1	BATT1	
BZ AI-155 03705	03705 5VDC BUZZER	1	BZ1	
CC 100nF-S 01065C	01065C Y5V 1206 COND	33	C10, C15, C17-19, C22, C25, C28, C38, C45, C49-52, C55, C62-63, C68-69, C78, C80-85, C87-88, C90, C92-95	
CC 15pF-S 01088	01088 SMD 1206 COND	2	C74-75	
CC 1nF-S 01096	01096 SMD 1206 COND	20	C12-14, C31-33, C42-43, C53-54, C56-58, C60-61, C66, C76-77, C79, C86	
CC 1uF100V-S 01760A	01760A Y5V 1206 COND<<50 V>>	8	C21, C23, C37, C64-65, C67, C71-72	
CC 220pF-S 01093	01093 SMD 1206 COND	8	C2-9	
CC 47pF-S 01100	01100 SMD 1206 COND	8	C20, C30, C35-36, C40-41, C48, C59	
CE 10uF16V-S	01626B TANT. ELETTR SMD CO	8	C24, C26-27, C29, C34, C39, C46-47	
CE 1uF50V-S 01763A	01763A ELETTR SMD COND	2	C89, C91	
CE 220uF50V LOW ESR	1799A ELETTR SMD COND LOW ESR	4	C16, C44, C70, C73	
CE 47uF35V-S 01790A	01790A ELETTR SMD COND	1	C11	
CE 47uF50V-S 01791C	01791C ELETTR SMD COND	1	C1	
D 1N4148-S 03002	03002 SMD DIODE	4	D12-13, D17, D19	
D 50WQ06FN	03019A SMD DIODE SCHOTTKY 5,5A	1	D9	
D BAS85-S	03024 SMD DIODE SCHOTTKY	8	D1-8	
D BAT54S	03199 SMD SCHOTTKY DIODE A-K T	6	D10-11, D14-16, D18	
DIS WG240128B	03083 240/128 DOT MATRIX LCD	1	LCD1	
DL KA-3528SGC 03057	03057 GREEN SMD LED DIODE	1	DL1	
DL LEDG3 03053	03053 GREEN LED DIODE 3mm	1	DL3	
DL LEDR3 03058	03058 RED LED DIODE 3mm	4	DL2, DL4, DL6-7	
DL LEDY3 03051	03051 YELLOW LED DIODE 3mm	1	DL5	
IC 24LC64 04815	04815 SMD INTEG CIRCUIT	1	IC7	
IC 74HC00-S 4762A	4762A SMD INTEG CIRCUIT	1	IC19	
IC 82B715-S 04734A	04734A SMD INTEG CIRCUIT	1	IC17	
IC CD4053BC-S 04710A	04710A SMD INTEG CIRCUIT	1	IC12	
IC LM2596S-5.0	04580 SMD INTEG CIRCUIT	1	IC14	
IC LM75-S 00668	00668 SMD INTEG CIRCUIT	1	IC8	
IC LMC6482-S	04632 SMD INTEG CIRCUIT	1	IC20	
IC LMC6484-S	04634 SMD INTEG CIRCUIT	4	IC2-5	
IC M41T56 04611	04611 SMD INTEG CIRCUIT	1	IC6	
IC MAX232-S 04804B	04804B SMD INTEG CIRCUIT	1	IC16	
IC MAX3080-S 04770	04770 SMD INTEG CIRCUIT	1	IC22	
IC MAX3080-S N.M.	NOT MOUNTED SMD INTEG CIRCUIT	1	IC18	
IC MAX942CSA-S	04572 SMD INTEG CIRCUIT	4	IC9-11, IC13	
IC MB90F543PF	04596 SMD INTEG CIRCUIT	1	IC15	
IC MPC100T-450I-TT	04577 SMD INTEG CIRCUIT	1	IC21	
IC ULN2003A 4870	04870 SMD INTEG CIRCUIT	2	IC1, IC23	
IND MS85 10uH-S	04948 INDUCTOR 2,7A	1	L1	
IND T100uH-1.8A 4958	04958 TOROIDAL-STORAGE CHOKES	1	L2	

Part Name/Number	Description	Qty.	Comps.	Page 2/2
INV IN-D43A-5V	03085 DC/AC MODULE	1	INV1	
JDB9_F-0° LT	02794 PCB CONNECTOR DB9 LONG T	1	J6	
JFC-10P 02697-02699	02697+02699 PCB CONNECTOR POL	2	J11, J13	
JFC-16P 02701-02700	02701+02700 PCB CONNECTOR POL	2	J12, J14	
JFC-26P 02855-02854	02855+02854 PCB CONNECTOR POL	1	J10	
J PAN2 02739	02739 PCB CONNECTOR	1	J4	
J PAN2 02739-40-41	02739+02740+02741 PCB CONNECTO	1	J5	
J PAN3 02707	02707 PCB CONNECTOR	3	J1-3	
J PAN3 NOT MOUNTED	NOT MOUNTED PCB CONNECTOR	2	J8-9	
J SCREWCONN2 02853	02853 PCB SCREW CONNECTOR	1	J7	
JU JUMP3 02707-02742	02707+02742 MASCHIO PAN3	4	JP1-4	
R 100R-S 00029A	00029A RES 1/4W 5% SMD 1206	6	R109, R114, R119-121, R123	
R 10K-S 00053A	00053A RES 1/4W 5% SMD 1206	37	R22-27, R30, R32-33, R40, R47, R50, R57, R68, R81-82, R85, R90-101, R105-108, R116, R118, R122, R124	
R 120R-S 00030A	00030A RES 1/4W 5% SMD 1206	2	R112-113	
R 1K0-S 00041A	00041A RES 1/4W 5% SMD 1206	5	R46, R54, R87-88, R104	
R 1K5-S 00043A	00043A RES 1/4W 5% SMD 1206	2	R110-111	
R 22K-S 00057A	00057A RES 1/4W 5% SMD 1206	11	R18, R20-21, R28, R34, R36, R38-39, R41, R43-44	
R 2K2-S 00045A	00045A RES 1/4W 5% SMD 1206	8	R19, R35, R37, R42, R45, R53, R59-60	
R 330R-S 00035B	00035B RES 1/4W 5% SMD 1206	2	R89, R103	
R 33R-S 00023A	00023A RES 1/4W 5% SMD 1206	2	R86, R102	
R 470K-S 00073A	00073A RES 1/4W 5% SMD 1206	8	R48-49, R51-52, R55-56, R58, R65	
R 470R-S 00037A	00037A RES 1/4W 5% SMD 1206	30	R10-17, R29, R31, R61-64, R66-67, R69-80, R83-84	
R 4K7-S 00049A	00049A RES 1/4W 5% SMD 1206	1	R117	
R 820R-S 00040A	00040A RES 1/4W 5% SMD 1206	1	R9	
RL 30.22.24 07569	07569 RELE	5	RLY1-5	
RV 10K-S-H 00715	00715 VARIABLE RESISTOR	1	R115	
RV 1M-3266X	00815 VARIABLE RESISTOR	8	R1-8	
SW SWITCH-4DIP 90°	07531A PCB DIP SWITCH 90°	1	SW1	
SW SWITCH-8DIP	07530A PCB DIP SWITCH SMD	1	SW2	
T 06086 N 7630 7632	7630 7632 KTI06086 PULSANTE 2	4	T1-4	
TR BC848 03457	03457 NPN SMD TRANSISTOR	1	TR1	
XTAL 32.768k-S 05146	05146 QUARTZ	1	XTAL1	
XTAL 4MHz-S 05101A	05101A QUARTZ	1	XTAL2	

DESCRIPTION

SCH0110B is a simple board with 8 BNC connectors (only some of them can be mounted depending on the transmitter). It routes all the 8 analog input signals (usually for power monitoring) on a IDC connector for simple wiring with the display board.

SCH0110BR0 Component layout

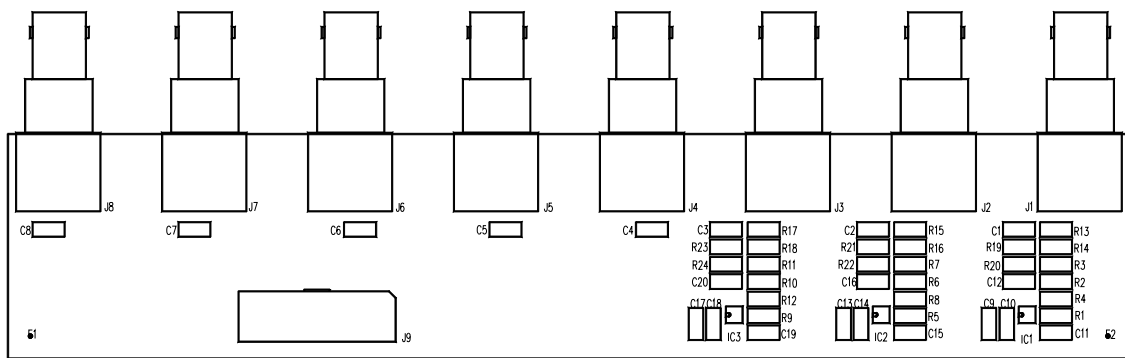

SCH0110BR0 COMPONENT LIST

Part Name/Number	Description	Qty.	Comps.
CC 1206 N. M.	N. M. SMD 1206 CAPACITOR	17	C4-20
CC 1nF-S 01096	01096 SMD 1206 CAPACITOR	3	C1-3
JBNC-90G-PCB 2034	02034 PCB CONNECTOR	3	J1-3
JBNC-90G-PCB 2034	N. M. BNC-90G	5	J4-8
JFC-16P 02701-02700	02701+02700 PCB CONNECTOR POL	1	J9
R 0R0-S 00001	00001 RES 1/4W 5% SMD 1206	6	R13, R15, R17, R19, R21, R23
R 1206 N. M.	N. M. RES 1/4W 5% SMD 1206	18	R1-12, R14, R16, R18, R20, R22, R24
Z MICRO SOIC 8P N.M.	SMD INTEG CIRCUIT NOT MOUNTED	3	IC1-3

DESCRIPTION

The SCH0152A board is based on three relays, each for one power connector (DRIVER1 POWER, DRIVER2 POWER, FANS POWER). The board is directly connected to the mains power supply and controlled by the SCH0239A (Control Board). When the microcontroller on SCH0239A decides to switch-on the DRIVER1, for example, it activates the regarding relay on SCH0152A, connecting the main power supply with the DRIVER1 POWER.

SCH0152AR0 Component layout

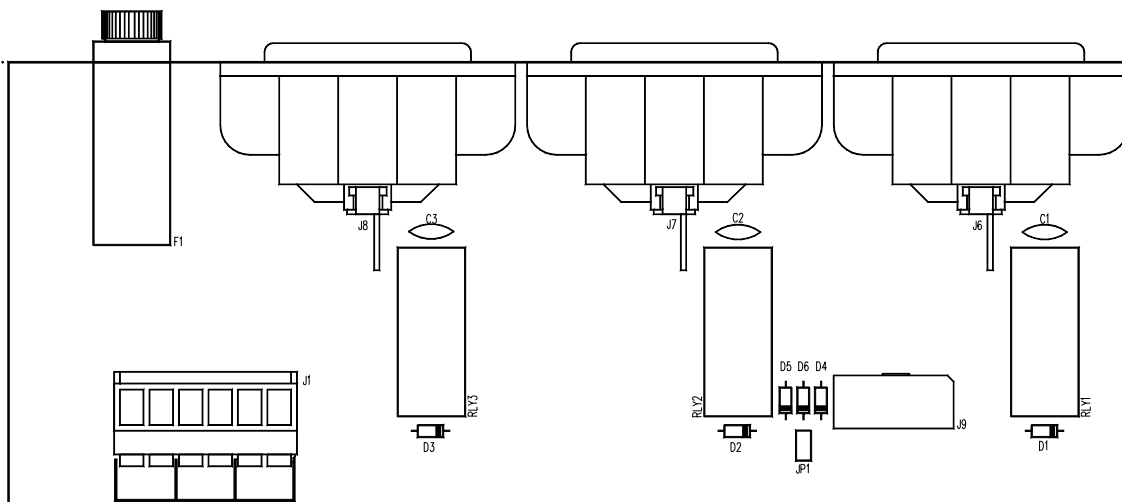

SCH0152AR0 COMPONENT LIST

Part Name/Number	Description	Qty.	Comps.
CC 2nF2 2kV 01045A	01045A CERAMIC CAPACITOR	3	C1-3
D 1N4148 03001	03001 DIODE	6	D1-6
FUSE OMEGA C1034	FUS00008 FUSE-HOLDER 5x20 D	1	F1
J CON HD515V/05-6PVE	02883 + 02884 PANDUIT PCB CONN	1	J1
J FC-10P 02697-02699	02697+02699 PCB CONNECTOR POL	1	J9
J VASCHETTA IEC	02879 VASCHETTA FEMALE PCB	3	J6-8
JU JUMP2 02739-02742	02739+02742 MALE PAN2	1	JP1
RL 40.31.24	7567C RELE	3	RLY1-3

DESCRIPTION

Several connectors are present on SCH0241A: 2 D-SUB9F for the RS485 AMs bus, 1 D-SUB9F for RS485 dedicated to the remote control, 2 BNC for Interlock and Fans control, 2 dual-poles connectors for +24Vdc power supply output, 1 fuse-holder that accepts the fuse for +24Vdc power signal.

As the other boards, SCH0241A is connected with display board. Also, it is directly connected to the output of the internal AC/DC power supply (+24Vdc).

SCH0241AR0 Component layout

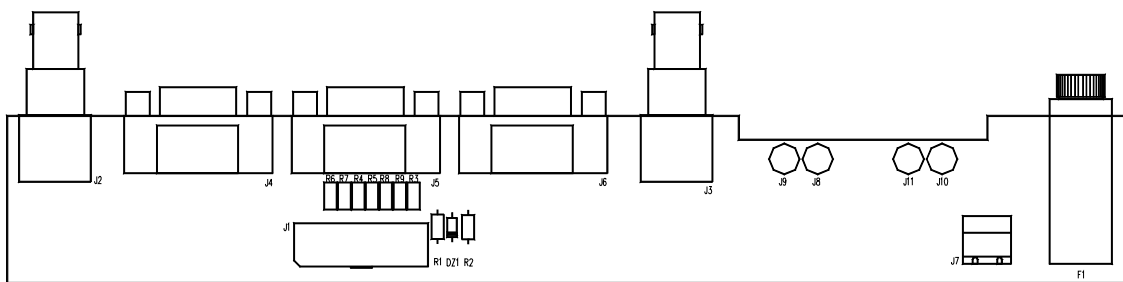

SCH0241AR0 COMPONENT LIST

Part Name/Number	Description	Qty.	Comps.
DZ 5V1 03109	03109 ZENER DIODE	1	DZ1
FUSE OMEGA C1034	FUS00008 PORTA FUSIBILE 5x20 D	1	F1
JBNC-90G-PCB 2034	02034 PCB CONNECTOR	2	J2-3
JDB9-90G 02797	02797 PCB CONNECTOR	3	J4-6
JFC-16P 02701-02700	02701+02700 PCB CONNECTOR POL	1	J1
JSCREWCONN2 02853	02853 PCB SCREW CONNECTOR	1	J7
JTESTP2.5mm 07912	07912 TEST POINT	4	J8-11
R 0R0-S 00001	00001 RES 1/4W 5% SMD 1206	7	R3-9
R 10K 0053	0053 RES 1/4W 5%	1	R1
R 1K0 0041	0041 RES 1/4W 5%	1	R2



MAIN FEATURES

- Universal AC input / Full range
- Protections: Short circuit / Over load / Over voltage
- Cooling by free air convection
- 100% full load burn-in test
- Fixed switching frequency at 50kHz

MECHANICAL SPECIFICATION

PIN N°	ASSIGNMENT
--------	------------

1	AC/L
2	AC/N
3	FG
4	DC OUTPUT -V
5	DC OUTPUT +V

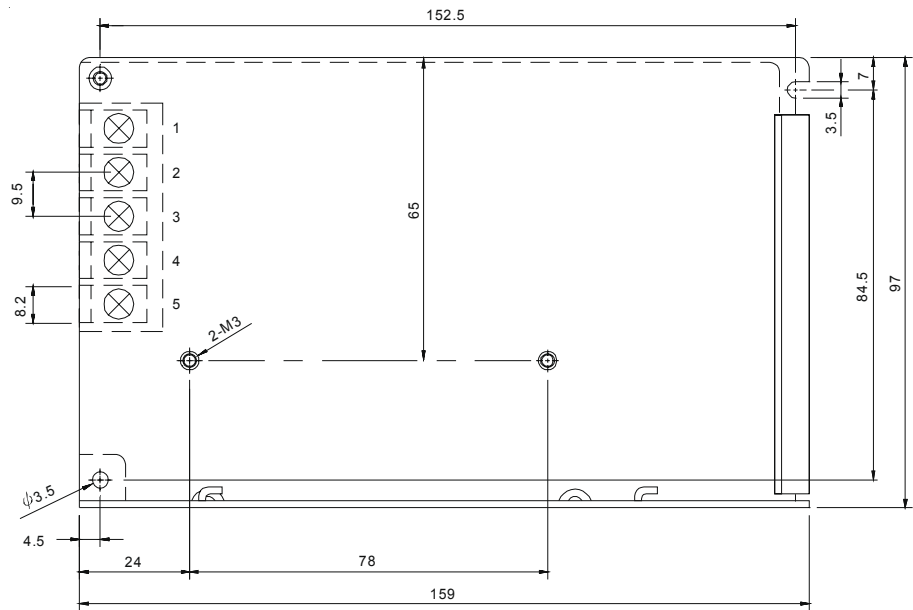

TECHNICAL CHARACTERISTICS

MODEL		S-60-15	S-60-24
OUTPUT	DC VOLTAGE	15V	24V
	RATED CURRENT	4A	2.5A
	CURRENT RANGE	0 ~ 4A	0 ~ 2.5A
	RATED POWER	60W	60W
	RIPPLE & NOISE (max.) Note 2	150mVp-p	150mVp-p
	VOLTAGE ADJ. RANGE	13.5 ~ 16.5V	21.6 ~ 26.4V
	VOLTAGE TOLERANCE Note 3	± 1.0%	± 1.0%
	LINE REGULATION	± 0.5%	± 0.5%
	LOAD REGULATION	± 0.5%	± 0.5%
	SETUP, RISE, HOLD TIME	300ms, 50ms, 80ms / 230VAC 800ms, 50ms, 10ms / 115VAC at full load	
INPUT	VOLTAGE RANGE	88 ~ 264VAC 120 ~ 370VDC	
	FREQUENCY RANGE	47 ~ 63Hz	
	EFFICIENCY (Typ.)	77%	79%
	AC CURRENT	24A/115VAC 1A/230VAC	
	INRUSH CURRENT (Max.)	COLD START 30A/115VAC 60A/230VAC	
	LEAKAGE CURRENT	<3.5mA/240VAC	
PROTECTION	OVER LOAD	105 ~ 150% rated output power	
		Protection type: Hiccup mode, recovers automatically after fault condition is removed	
	OVER VOLTAGE	17.25 ~ 20.25V	27.6 ~ 32.4V
		Protection type: Hiccup mode, recovers automatically after fault condition is removed	
ENVIRONMENT	WORKING TEMP.	-10 ~ +60°C (Refer to output load derating curve)	
	WORKING HUMIDITY	20 ~ 90% RH non-condensing	
	STORAGE TEMP., HUMIDITY	-20 ~ +85°C, 10 ~ 95% RH	
	TEMP. COEFFICIENT	± 0.03%/°C (0 ~ 50°C)	
	VIBRATION	10 ~ 500Hz, 2G 10min./1cycle, period for 60min. each along X, Y, Z axes	
SAFETY & EMC (Note 4)	SAFETY STANDARDS	UL1012, UL1950, TUV EN60950 Approved	
	WITHSTAND VOLTAGE	I/P-O/P:3KVAC I/P-FG:1.5KVAC O/P-FG:0.5KVAC	
	ISOLATION RESISTANCE	I/P-O/P, I/P-FG, O/P-GD:100M Ohms/500VDC	
	EMI CONDUCTION & RADIATION	Compliance to EN55022 (CISPR22) Class B	
	HARMONIC CURRENT	Compliance to EN61000-3-2,-3	
	EMS IMMUNITY	Compliance to EN61000-4-2,3,4,5,6,8,11; ENV50204, EN55024, Light industry level, criteria A	
OTHERS	MTBF	316.2K hrs min. MIL-HDBK-217F (25°C)	
	DIMENSION	159*97*38mm (L*W*H)	
	PACKING	0.51kg; 24pcs/13.1kg/0.7CUFT	