



ATSC TRANSMITTER
Digital TV

Technical Manual

	CODE	APD043A APD047A APD045A	TITLE	ATSC TRANSMITTER	REV	0	DATE	20/02/08
---	------	-------------------------------	-------	------------------	-----	---	------	----------

ATSC Transmitter Family

CODE	MODEL
-------------	--------------

APD043A	ATSC UHF TRANSMITTER
APD047A	ATSC VHF-III TRANSMITTER
APD045A	ATSC VHF-I TRANSMITTER



Registration number: **IT-17686**



Registration number: **IT-24436**

CE 0682 

SS 96 Km 113
70027 Palo del Colle (Ba) **ITALY**
Tel. +39 (0)80 626755
Fax +39 (0)80 629262
E-mail: elettronika@elettronika.it
Web site: <http://www.elettronika.it>

ATSC Transmitter Family	2
Summaries	3
Warning	7
Warranty	8
Introduction	9
Content of the manual	9
Treatment of electrical shock	11
<i>First-aid</i>	12
<i>Treatment of electrical burns</i>	12
<i>Note</i>	12
RoHS Normative	13
ATSC TRANSMITTER	15
Section 1 - Information	17
1.1 <i>Description</i>	18
1.2 <i>Main Features</i>	18
1.3 <i>Technical Characteristics</i>	19
<i>Front panel</i>	20
<i>Rear panel</i>	21
<i>Block Diagram</i>	22
1.4 <i>Operational Details</i>	23
1.4.1 <i>TS Input Management</i>	23
- <i>Redundancy management</i>	23
- <i>Reed Solomon FEC</i>	24
- <i>Bit rate adaptation</i>	24
- <i>Squelch</i>	24
1.4.2 <i>Synchronization and Clocks</i>	24
1.4.3 <i>Output Signal</i>	25
1.4.4 <i>Non-Linear Precorrection</i>	25
1.4.5 <i>Linear Precorrection</i>	25
1.4.6 <i>Control of the equipment</i>	26
1.4.7 <i>Test Modes</i>	26
1.4.8 <i>Power Handling</i>	26
1.4.9 <i>Alarms and Automation</i>	27
1.4.10 <i>AGC: Implementation and Details</i>	29
ATSC TRANSMITTER AGC Cable	31
1.4.11 <i>Log</i>	32
Section 2 - Installation	33
2.1 <i>Operating Environment</i>	34

2.2 First Installation	34
2.3 ATSC TRANSMITTER with GPS Clock Source	35
2.4 ATSC TRANSMITTER remote control with Elettronika RCU	35
2.5 ATSC TRANSMITTER with PC	36
Section 3 - Operation	37
3.1 Local Control	38
3.2 LEDs	38
3.3 Menu Management	39
3.3.1 Title Bar	39
3.3.2 Status Bar	39
3.3.3 Diagram Screen	40
3.3.4 Browsing the menus and parameters	41
3.3.5 Composition of a menu	42
3.4 Parameters and menu description	44
3.4.1 Input Menu	44
- Configuration Submenu	44
- Stream1 Errors Submenu	46
- Stream2 Errors Submenu	46
3.4.2 Modulation Menu	47
3.4.3 RF Menu	48
- Frequency Submenu	49
- Power Submenu	50
- Amplifier Submenu	52
- Output Submenu	53
- Precorrection Submenu	54
3.4.4 Setup Menu	55
- Control Submenu	56
- Display Submenu	57
- Clock Submenu	57
- Power Supply Submenu	58
- Versions Submenu	58
3.5 Log Screen	59
3.6 Alarm Screen	59
3.7 Firmware Upgrade	59
ATSC TRANSMITTER Menu Map	61
Section 4 - Diagram	63
- APD043A ATSC TRANSMITTER Cable Diagram	64
- APD047A ATSC TRANSMITTER Cable Diagram	65

- APD045A ATSC TRANSMITTER Cable Diagram	66
- APD043A_APD047A_APD045A ATSC TRANSMITTER Component list	67
- SCH0135A Control Board and Display	69
- Description	69
- Dip-switch	69
- Technical Characteristics	69
- SCH0135A Top layer Component layout	70
- SCH0135A Bottom layer Component layout	71
- SCH0135A Component list	72
- SCH0135A Electric Diagram	74
- A1592 ATSC UHF Modulator Module	77
- Description	77
- Main Features	77
- Connectors	77
- A1703 ATSC VHF-I/III Modulator Module	78
- Description	78
- Main Features	78
- Connectors	78
- MTF0116A 5W UHF RMS Amplifier Module	79
- Description	79
- Technical Characteristics	79
- MTF0116A Component list	79
- MTF0116A Component layout	80
- SCH0417A Component layout	81
- SCH0417A Component list	82
- SCH0417A Electric Diagram	83
- MTF0118A 5W VHF-I/III RMS Amplifier Module	86
- Description	86
- Technical Characteristics	86
- MTF0118A Component list	86
- MTF0118A Component layout	87
- SCH0436A Component layout	88
- SCH0436A Component list	89
- SCH0436A Electric Diagram	91
- MTF0125A 5W VHF-I RMS Amplifier Module	92
- Description	92
- Technical Characteristics	92
- MTF0125A Component list	92

- MTF0125A Component layout	93
- SCH0320A Component layout	94
- SCH0320A Component list	95
- SCH0320A Electric Diagram	96
- SCH0388B Power Supply Interface Board	97
- SCH0388B Power Supply Interface Board Component layout	97
- SCH0388B Component list	98
- SCH0388B Electric Diagram	99
- E0064 SP-320-27/48 Switching power supply	100
- Main Features	100
- Mechanical Specifications	100
- Technical Characteristics	101

WARNING

The apparatus described in this manual has been designed and manufactured with devices to safeguard the users. In any case it is recommended that during any operation of installation, maintenance, miscellaneous interventions and calibrations requiring the apparatus to be switched on,

THE USER TAKES ALL THE PRECAUTIONS AGAINST INCIDENTS

It is required to use the proper clothes and protection gloves in order to prevent damages from incidental contacts with high-voltage parts.

The manufacturer declines every responsibility in case the recommendations above are not followed.

IMPORTANT

The component lists attached to the relevant electrical diagrams indicate for each item the reference, the description and the type normally used.

The ***Eletronika S.r.l.*** though reserves the right to use or supply as spare parts components with equivalent characteristics but of a different type, assuring anyway the optimal work of the apparatus in accordance with the specifications.

The enclosed monographs are solely owned by ***Eletronika S.r.l.***

The use of anything enclosed in this technical manual without explicit authorization given by ***Eletronika S.r.l.*** will be prosecuted by the law.

The data and technical characteristics of the apparatus described in this manual are not compelling for the manufacturer.

The ***Eletronika S.r.l.*** reserves the right to make, without previous notice, modifications or updates in order to improve the quality of the product.

The general conditions of supply and sale are described in the contracts.

The delivery time are in accordance with the products and quantities ordered.

Summary of warranty

We, ELETTRONIKA S.r.l., SS096 Km 113 Z.I. PALO DEL COLLE (BA) ITALY, warrant to the ORIGINAL PURCHASER of a NEW product, for a period of one (1) year from the date of purchase by the original purchaser (the "warranty period") that the new ELETTRONIKA product is free of defects in materials and workmanship and will meet or exceed all advertised specifications for such a product. This warranty does not extend to any subsequent purchaser or user, and automatically terminates upon sale or other disposition of our product.

Items excluded from this ELETTRONIKA warranty

We are not responsible for product failure caused by misuse, accident, or neglect. This warranty does not extend to any product on which the serial number has been defaced, altered, or removed. It does not cover damage to loads or any other products or accessories resulting from ELETTRONIKA product failure. It does not cover defects or damage caused by use of unauthorized modifications, accessories, parts, or service.

What we will do

We will remedy any defect, in material or workmanship (except as excluded), in our sole discretion, by repair, replacement, or refund. If a refund is elected, then you must make the defective or malfunctioning component available to us free and clear of all liens or other encumbrances. The refund will be equal to the actual purchase price, not including interest, insurance, closing costs, and other finance charges less a reasonable depreciation on the product from the date of original purchase. Warranty work can only be performed at our authorized service centers or at our factory. Expenses in remedying the defect will be borne by ELETTRONIKA, including one-way surface freight shipping costs within the United States. (Purchaser must bear the expense of shipping the product between any foreign country and the port of entry in the United States and all taxes, duties, and other custom's fees for such foreign shipments).

How to obtain warranty service

You must notify us of your need for warranty service not later than ninety (90) days after the expiration of the warranty period. We will give you an authorization to return the product for service. All components must be shipped in a factory pack or equivalent which, if needed, may

Disclaimer of consequential and incidental damages

You are not entitled to recover from us any consequential or incidental damages resulting from any defect in our product. This includes any damage to another product or products resulting from such a defect.

Warranty alterations

No person has the authority to enlarge, or modify this warranty. The warranty is not extended by the length of time for which you are deprived of the use of the product. Repairs and replacement parts are provided under the terms of this warranty shall carry only the unexpired portion of this warranty.

Design changes

We reserve the right to change the design of any product from time to time without notice and with no obligation to make corresponding changes in products previously manufactured.

Legal remedies of purchaser

There is no warranty which extends beyond the terms hereof. This written warranty is given in lieu of any oral or implied warranties not contained herein. We disclaim all implied warranties, including without limitation any warranties of merchantability or fitness for a particular purpose. No action to enforce this warranty shall be commenced later than ninety (90) days after expiration of the warranty period.

Warranty for electronic tubes

The warranty applied for electronic tubes is the one given by the manufacturer of the tube. In the event that the product shows anomalies within the deadline of the validity of the warranty given by the manufacturer of the product itself, the buyer will have to return it to the seller with the needed documents and the written description of the defect. The seller will ship the broken tube to the manufacturer in order to effect the necessary technical tests to find out the cause of the anomaly. Meanwhile the buyer of the tube who needs to use, and as such to replace immediately the product, will have to buy a new one and provide to the relevant payment, further to the issuing by the seller of a regular commercial invoice. After the adequate tests made by the manufacturer, should the result be positive, that is confirm the defect in manufacturing, the seller will issue a regular credit note in the name of the buyer and return the amount paid. Should the result be negative, that is detect a negligence in the installation or use by the buyer, he will have no right against the seller.

INTRODUCTION

The apparatus described in this manual is the latest of this series, offering high performances, remarkable reliability and a wide range of characteristics, it all at a competitive cost.

Its is easy to install and use. It only takes to follow the installation procedure as shown in this manual: after having removed all from the package, you only have to follow step by step the description in the various sections.

Before starting to use the apparatus, remember to:

- read carefully the general safety information contained in this section;
- follow the instructions for the installation and set up of the apparatus;
- read all the remaining sections of this manual in order to know well the apparatus and learn how to obtain the best of its characteristics.

CONTENTS OF THE MANUAL

The chapter composing this manual contain all the information concerning the use of the apparatus. For more information refer to ELETTRONIKA S.r.l.

This manual is made up of different chapters, each made up of various sections.

WARNING!

The currents and voltages in this equipment are dangerous!
Personnel must at all times observe safety regulation!

This manual is intended as a general guide for trained and qualified personnel who are aware of the dangers inherent in handling potentially hazardous electrical and electronic circuits. It is not intended to contain a complete statement of all safety precautions which should be observed by personnel in using this or other electronic equipment.

The installation, operation, maintenance and service of this equipment involves risks both to personnel and equipment, and must be performed only by qualified personnel exercising due care. Elettronika S.r.l. shall not be responsible for injury or damage resulting from improper procedures or from the use of improperly trained or inexperienced personnel performing such tasks.

During installation and operation of this equipment, local building codes and fire protection standards must be observed.

WARNING!

Always disconnect power before opening covers, doors, enclosures, gates, panels or shields.
Always use grounding nsticks and short out high voltage points before servicing. Never make internal adjustments, perform maintenance or service when alone or when fatigued.

Do not remove, short-circuit or tamper with interlock switches on access covers, doors, enclosures, gates, panels or shields.
Keep away from live circuits, know your equipment and don't take chances.

WARNING!

In case of emergency ensure that power has been disconnected.

Treatment of electrical shock

1) If victim is not responsive follow the A, B, C's of basic life support.

PLACE VICTIM FLAT ON HIS BACK ON A HARD SURFACE

A - AIRWAY



If unconscious, open airway lift up neck, push forehead back, clear out mouth if necessary, observe for breathing.

B - BREATHING

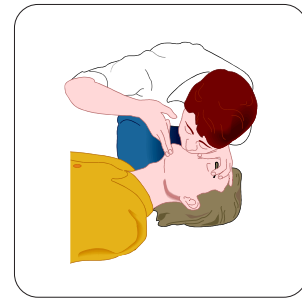

If not breathing, begin artificial breathing. Tilt head, pinch nostrils, make airtight seal, 4 quick full breaths. Remember mouth to mouth resuscitation must be commenced as soon as possible.

C - CIRCULATION

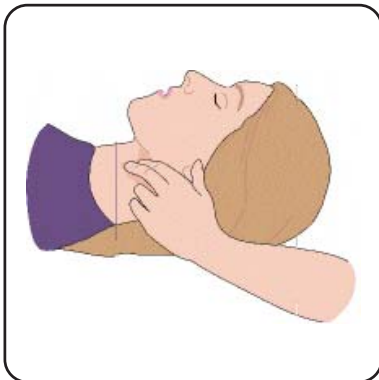

Check carotid pulse. If pulse absent, begin artificial circulation.

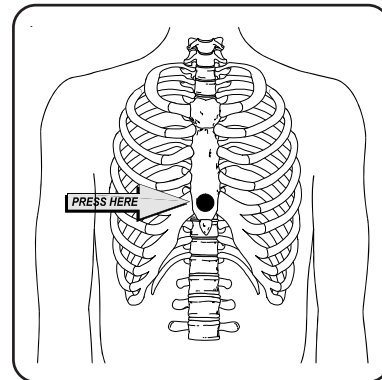

Approx. 80sec.: 1 rescuer, 15 compressions, 2 quick breaths.

Approx. 60sec.: 2 rescuers, 5 compressions, 1 breath.

NOTE: DO NOT INTERRUPT RHYTHM OF COMPRESSIONS WHEN SECOND PERSON IS GIVING BREATH.

Call for medical assistance as soon as possible.

2) If victim is responsive:

- keep them warm;
- keep them as quiet as possible;
- loosen their clothing (a reclining position is recommended).

FIRST-AID

Personnel engaged in the installation, operation, maintenance or servicing of this equipment are urged to become familiar with first-aid theory and practices. The following information is not intended to be a complete first-aid procedure, it is brief and is only to be used as a reference. It is the duty of all personnel using the equipment to be prepared to give adequate Emergency First Aid and thereby prevent avoidable loss of life.

TREATMENT OF ELECTRICAL BURNS

1) Extensive burned and broken skin.

- Cover area with clean sheet or cloth (cleansed available cloth article);
- do not break blisters, remove tissue, remove adhered particles of clothing, or apply any salve or ointment;
- treat victim for shock as required;
- arrange transportation to a hospital as quickly as possible;
- if arms or legs are effected keep them elevated.

NOTE

If medical help will not be available within an hour and the victim is conscious and not vomiting, give him a weak solution of salt and soda: 1 level teaspoonful of salt and 1/2 level teaspoonful of baking soda to each quart of water (neither hot or cold).

Allow victim to sip slowly about 4 ounces (half a glass) over a period of 15 minutes.

Discontinue fluid if vomiting occurs (do not give alcohol).

2) Less severe burns - (1st & 2nd degree).

- Apply cool (not ice cold) compresses using the cleansed available cloth article;
- do not break blisters, remove tissue, remove adhered particles of clothing, or apply salve or ointment;
- apply clean dry dressing if necessary;
- treat victim for shock as required;
- arrange transportation to a hospital as quickly as possible;
- if arms or legs are affected keep them elevated.

Communication N°1 -2002/95/CE - RoHS Directive

Further to the directives issued by the European Community, 2002/95/CE, 2002/95/CE and 2003/108/CE, and to the Italian Decree of Law n° 151 dated 25 July 2005, this is to inform the customers of Elettronika S.r.l. living within the boundaries of the European Community about the following obligations:

- 1) It is forbidden to trash RAEE products (which includes all broadcasting products which are not expressly labelled as lead-free) along with normal wastes;
- 2) Such devices must be brought to proper centres able to perform the adequate processing in order to recycle their parts where possible and dispose of the raw materials contained therein;
- 3) For equipment purchased from Elettronika after the 13th of August 2005, the gathering, transport, processing, recycle and disposal operations are responsibility of Elettronika who will bear all related expenses;
- 4) For equipment purchased from Elettronika before the 13th of August 2005, the gathering, transport, processing, recycle and disposal operations are responsibility of Elettronika, who will bear all related expenses, only if you are purchasing from us new equipment in substitution of the disposed one;
- 5) Electric and electronic devices contains lead in soldering, cables, etc. This substance pollutes the environment and may be accumulated in the organism of plants and mammals. It is dangerous for humans because it may affect blood, bone marrow, peripheral and central nervous system and kidneys, causing anaemia, encephalopathies (e.g., convulsions), peripheral neuropathies, cramps of the abdomen and kidney damages. Besides it affects human reproduction and growth.
These devices also contain mercury. From the environmental point of view, this substance is highly toxic for aquatic life, and can be accumulated in the organism of fish.
Long-term damages to humans can affect the central nervous system and the kidneys, producing irritability, emotional instability, tremors, damages to the mind and the memory, language disorders. It may also irritate and whiten the gums, and its effects may be cumulative. Based on tests on animals, it may affect the human reproduction or growth.
There is also chrome, which may result in irritation of the eyes and respiration system.
Cadmium is also present. In humans it may damage lungs, due to repeated or prolonged contact with its dust, and kidneys. It may cause cancer.
- 6) The symbol below marks the devices which cannot be disposed of along with normal wastes, as stated in 1) and 2) above.



- 7) The payment of fees is foreseen for the non-allowed disposal of such devices.

This page is intentionally blank

DIGITAL TV



ATSC TRANSMITTER

User's manual

This page is intentionally blank

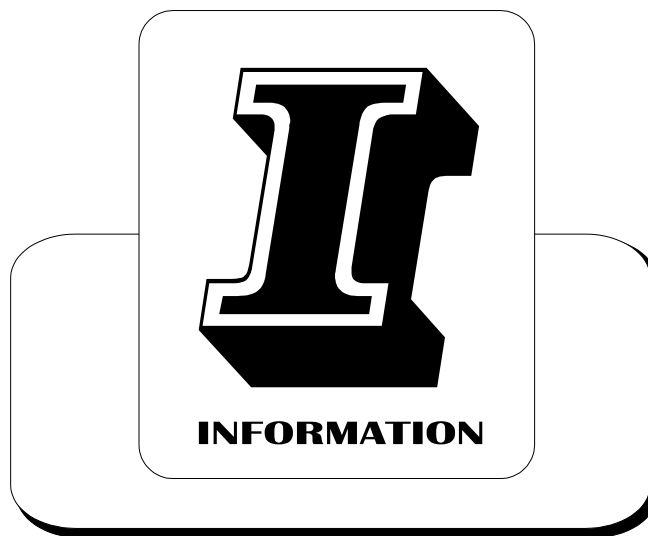

Section 1 - Information

Contents:

- 1.1 Description*
- 1.2 Main features*
- 1.3 Technical characteristics*
- Front Panel*
- Rear Panel*
- Block Diagram*
- 1.4 Operational details*

ATSC TRANSMITTER

1.1 DESCRIPTION

The ATSC TRANSMITTER is an 8-VSB ATSC professional exciter, designed for the most demanding digital TV broadcasting applications. It integrates a modulator module with up-to-date FPGA technology and advanced digital signal processing algorithms in order to generate an absolutely accurate output 8-VSB signal, with exceptionally optimized modulation and the output filtering techniques.

Very high linearity performances are possible thanks to very careful RF design over the entire VHF and UHF bands and with an optimal digital precorrection engine working simultaneously in the time and frequency domains. A high degree of reliability is guaranteed, moreover, by the use of oversized cooling devices and by control circuits operated by modern microprocessor technologies.

The ATSC TRANSMITTER can be used as a stand-alone 5W RMS transmitter or as a driver stage for amplifiers of greater power. The excellent spectral purity of the conversion oscillator lets the ATSC TRANSMITTER radiate an 8-VSB signal with an excellent MER value.

The ATSC TRANSMITTER is equipped with a powerful ASI/SMPTE inputs management block which allows to manage the Transport Stream (TS) inputs in a fully redundant configuration, thus significantly improving the reliability of the whole broadcasting system in every operating condition.

The ATSC TRANSMITTER is totally compliant to the A/53, A/54 and A/64 ATSC recommendations with 6MHz output channel bandwidth, in VHF and UHF bands.

1.2 MAIN FEATURES

- *Compact and cost competitive;*
- *Top-quality air cooling system;*
- *Agile output frequency step 1Hz over VHF and UHF bands;*
- *Complies and exceeds the ATSC recommendations;*
- *Multi-platform remote control;*
- *User-friendly Graphical User Interface;*
- *Very high power efficiency thanks to accurate digital precorrection;*
- *Easy frequency synchronization.*

1.3 TECHNICAL CHARACTERISTICS

SIGNAL PROCESSING SECTION

Reference Standard	ATSC A/53, A/54, A/64
ATSC Mode	8-VSB 2/3 Trellis Code
Constellation	8-VSB
Code Rate	2/3
Network Support	MFN
Bandwidth	6MHz
Digital Pre-Correction	Linear and Non-Linear
Automatic PCR Restamping	User enabled with Bitrate adaptation
Test Modes	23-bit PRBS Generator, Single-tone output

INPUT SECTION

TS Input	2 DVB-ASI + 2 SMPTE-310M inputs fully redundant
Input TS Format	SPTS/MPTS, Burst Mode - Continuous Mode (ASI inputs)
MPEG-2 Packet Length	188/204 bytes (ASI), 188 bytes (SMPTE)
Input Data Rate	19.392658Mbit/s (SMPTE), up to 60Mbit/s (ASI)
Internal VCTCXO 10MHz reference	
- Stability (full temperature range)	< 1ppm (0-50°C)
- Aging	< ±1ppm/year
- Tuning	±5ppm
10MHz output	0dBm ±3dB
External Frequency Reference	10MHz ±5ppm
Frequency Reference Interface	BNC, 50Ω, -15dBm to +15dBm

OUTPUT SECTION

RF Output Frequency	VHF band (57-240MHz) step 1Hz UHF band (470-860MHz) step 1Hz
Output Level	5W RMS
Output Interface	N type connector, 50Ω
Spectrum Polarity	Non-inverted and Inverted
Harmonics and Spurious	< -50dBc
Pilot Carrier phase noise	< -106dBc/Hz @20kHz
EVM	< 2.5% without equalizer
Inband SNR	> 32dB without equalizer
Shoulders	> 50dB
Inband ripple	< ±5dB

GENERAL

Physical	Case 19"-2U, 420mm deep, 12kg
Remote Control Port	RS232/RS485
Remote Control Options	PSTN, GSM, Ethernet, SNMP (with external unit)
Front Panel User Interface	LCD Display + Rotating knob + 3 LEDs
Power Supply Voltage	90 - 240VAC 50/60Hz
Power Consumption	150VA max
Operating Temperature	0 - 50°C

Specifications and characteristics are subject to change without notice

Front panel

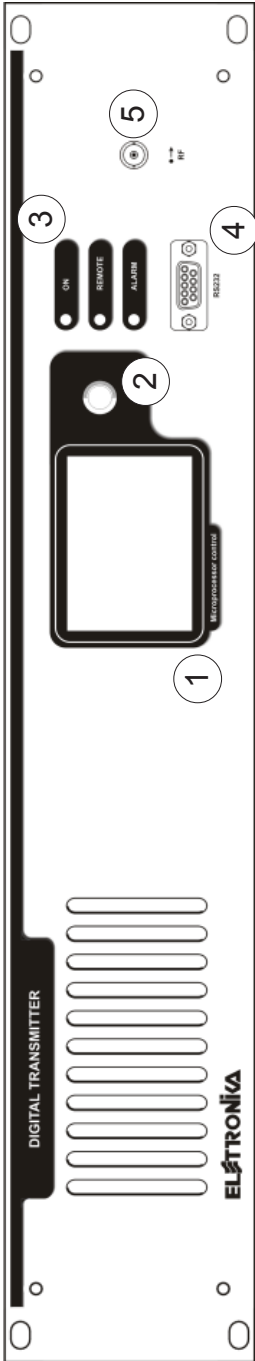

DESCRIPTION

1	Graphical LCD
2	Rotating Knob
3	Status LEDs
4	RS232 Socket
5	RF Monitor Connector

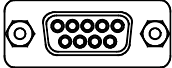

RS232 for Serial pin-to-pin connection to PC with ERCos software and for firmware upgrade

- Pin 2: TX
- Pin 3: RX
- Pin 5: GND

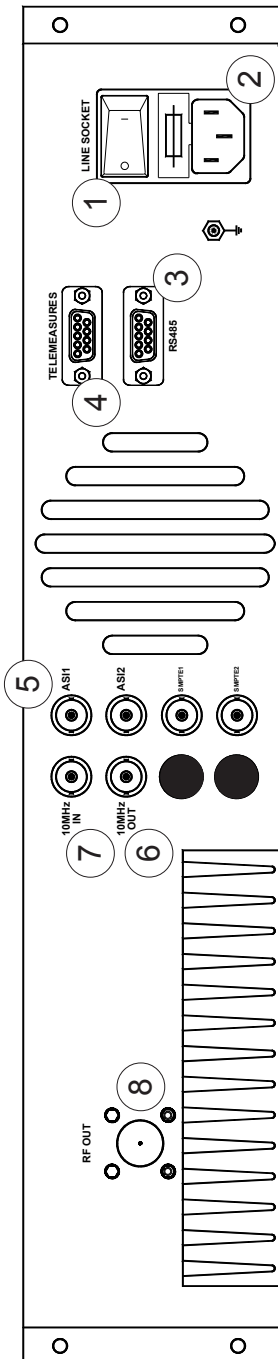

DESCRIPTION

1	Main Switch
2	AC Socket with Fuse-Holder (2A)
3	RS485 Socket
4	Telemasures Connector
5	TS Input Connectors - ASI1 Input - ASI2 Input - SMPTE1 Input - SMPTE2 Input
6	10MHz OUT Connector
7	10MHz IN Connector
8	RF Output Connector

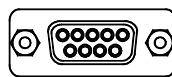

RS485
for Serial pin-to-pin connection
to RCU for remote control

- Pin 2: RX-
- Pin 3: RX+
- Pin 4: +5V
- Pin 5: GND
- Pin 6: +5V
- Pin 7: TX-
- Pin 8: TX+



Wired Telemasures connector

- Pin 1: FWD power (Analog out)
- Pin 2: REF power (Analog out)
- Pin 3: Temperature (Analog out)
- Pin 4: FWD power (Analog in)
- Pin 5: GND
- Pin 6-7: Alarm or Squelch (user selectable)
Alarm: Open=Normal / Closed=Alarm
Squelch: Open=No Squelch / Closed=Squelch
(Digital out, Free contact relay)
- Pin 8: External AGC Alarm (Digital in)
Open=Normal / GND=Alarm
- Pin 9: Remote ON/OFF (Digital in)
Open=ON / GND=OFF

Block diagram

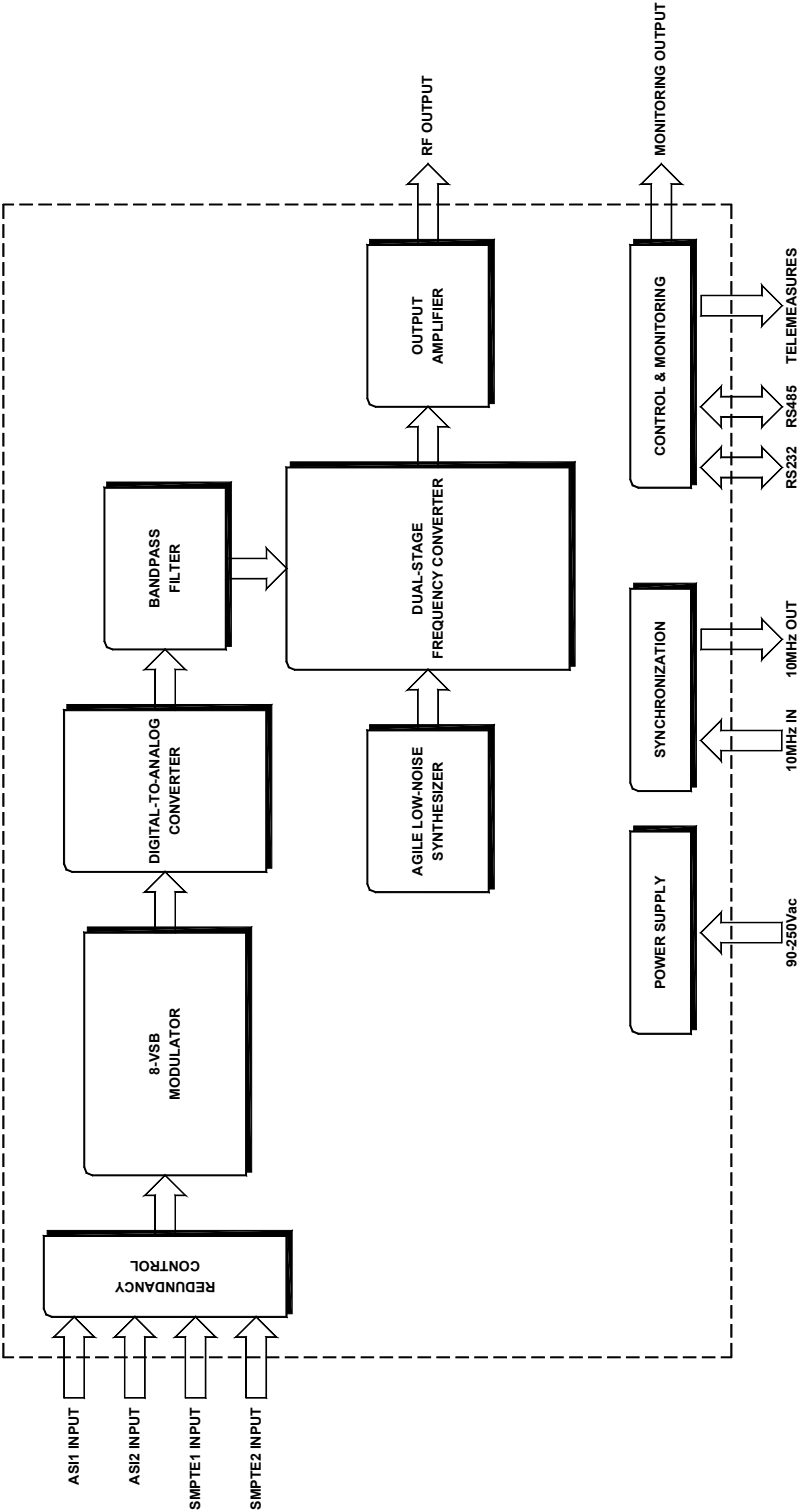

1.4 OPERATIONAL DETAILS

All the sections of the ATSC TRANSMITTER, as showed in the block diagram above, are described in this section in order to give the user a general understanding of the operations of the equipment.

1.4.1 TS INPUT MANAGEMENT

The ATSC TRANSMITTER is equipped with 2 ASI inputs and 2 SMPTE-310M inputs. Each input standard is available with two inputs in order to enable redundant operation for the transport stream input. You can decide to operate with SMPTE input or with ASI input depending on your network interfacing needs. In either case a complete redundancy is guaranteed thanks to a duplicated input.

The ATSC transmission scheme is built over a very stable and accurate data stream clock. The SMPTE-310M data clock shall have the exact standardized clock frequency. The modulator module takes its synchronization from this input data stream to be able to recover the same clock frequency. If an external clock reference is used (10 MHz), the global clock synchronization might be plesiochronous (i.e. not perfect synchronization between the multiplexer clock and the modulator reference clock). In that case, it is recommended to enable the "bit rate adaptation" on the ATSC TRANSMITTER.

When this mode of operation is enabled, the input processing module discards or inserts Null Packets in order to adapt the MPEG-TS input bit rate to the precise bit rate defined by the ATSC recommendation. PCR re-stamping is then executed accordingly.

The switching is not expected to be seamless. However, in case of feeding the exact data stream on both inputs (Primary & Secondary), then the ATSC TRANSMITTER performs a seamless switching from one to the other input. Switching is always performed on a packet basis.

The user may enable or disable the automatic mute when an error on the SMPTE-310M or on the ASI input is detected. The delay for the detection of the lost of SMPTE-310M is 1 second from its occurrence. In case the user disables the automatic mute, null packets are inserted in order to feed the modulator section with the exact ATSC bit rate.

Two test modes are available for testing and alignment procedures. The 23-bit PRBS test mode generates a pseudo-random data sequence in order to produce a correct output spectrum even in absence of a valid TS input. The single-tone test mode produces a sinusoidal output useful for frequency converters alignment. The test modes are useful only for testing purposes and shall not be used for real broadcasting operation.

- Redundancy management

When set in Automatic Switching mode (default), the input management unit automatically detects the presence of a valid MPEG Transport Stream (MPEG-TS) on the main or auxiliary inputs. If no valid MPEG-TS flow

is detected, the unit switches automatically to the other input. The periodic occurrence of the Sync byte in the MPEG-TS packets is used to decide if a MPEG-TS flow is valid or not. If the user chooses to operate in Manual switching mode then he has to force which input is active.

- Reed Solomon FEC

If the ASI incoming inputs (*note: only for ASI input mode*) include the Reed Solomon codes (204 bytes packets), the module performs the error correction thanks to the 16 RS bytes.

- Bit rate adaptation

When operating in ASI input mode, the input management unit can perform an automatic bit-rate adaptation, if required. When this mode of operation is activated, the unit automatically removes and/or inserts null packets in order to adapt the incoming ASI bit-rate to the exact bit-rate defined by the ATSC recommendation. PCR restamping is then executed in real time.

- Squelch

The RF output signal can be muted if one of the following conditions occurs:

- a hardware problem is present (for example, the amplifier temperature is too high, the modulator does not communicate with the controller and so on);
- an error in the input signals is present (input TS missing and Mute on input error feature enabled).

In the first condition, the output is muted to protect valuable internal parts of the equipment and/or save power. In the second condition, the output is muted because the signal is most probably unusable by receivers. This muting action is known as Squelch.

In a dual drive or 1+1 transmitter, the changeover control unit should discriminate if the output power reduction is caused by a hardware problem (the changeover takes place) or by an input signal problem (the changeover is not performed). The user can change the meaning of the digital output in the TLM port choosing "Alarm" (useful to interface a custom remote control system) or "Squelch" (useful to interface a changeover control unit).

1.4.2 SYNCHRONIZATION AND CLOCKS

The ATSC TRANSMITTER includes its own clock and synchronization generator. A high stability 10MHz VCTCXO provides the internal clock reference to the clock system of the digital processing section of the equipment. An external 10MHz reference may be used if a higher stability is needed, or if there is a need to lock the modulator processing clock or the output carrier frequency to an external reference (i.e. operation in frequency offset mode).

In special cases, the 10MHz internal clock may be locked to the system clock embedded into the ASI/SMPTE input signal. In this case, you can not enable the Bit-Rate Adaptation function and the input bit rate has to be the exact ATSC bit-rate (19.392658Mbit/s). If the ATSC TRANSMITTER is set up to operate with either of the two external references (from ASI/SMPTE input or from the external 10MHz reference), it will automatically switch to the internal reference if the external reference is missing. The switching from the

external 10MHz reference to the 10MHz internal clock is totally seamless. The processing clock of the numerical section of the ATSC TRANSMITTER is always locked to the internal or to the external 10MHz reference.

1.4.3 OUTPUT SIGNAL

The ATSC TRANSMITTER output signal is available at the output labelled RF OUT on a 50Ω N-type female connector. The frequency of the output signal can be set in the VHF and UHF bands, depending on the model type. The frequency can be set by choosing the standard/channel/offset combination (for example, UHF standard, channel 45 and offset 0Hz) or by choosing directly the center frequency of the output signal. An attenuated version of the output signal is available at the RF Monitor terminal located on the front panel of the equipment. The maximum nominal output level is 5W RMS, the output power level can be controlled in AGC (Automatic Gain Control) mode or in manual mode and can be adjusted by the rotating knob located on the front panel. The output signal may be muted either manually by the user or automatically depending on some given conditions. The mute can be direct (abrupt muting) or progressive (linearly decreasing function).

1.4.4 NON-LINEAR PRECORRECTION

Any solid-state or tube power amplifier will produce intermodulation distortion when fed by the ATSC 8-VSB signal. Non-linear precorrection is used to compensate the effects of these distortions in order to radiate a signal with the maximum possible MER value.

The ATSC TRANSMITTER is able to perform non-linear precorrection over a 20MHz bandwidth. For this purpose, two tables (AM-AM and AM-PM) of maximum 16 taps are used by the modulator.

The AM-AM precorrection table defines the AM-AM curve that will be applied to the output spectrum. For each tap, the abscissa can be defined from -12dB to +12dB by 0.05dB step and the ordinate can be defined from -6dB to +6dB by 0.05dB step.

The AM-PM precorrection table defines the AM-PM curve that will be applied to the output spectrum. For each tap, the abscissa can be defined from -12dB to +12dB by 0.05 step and the ordinate can be defined from -25 degrees to +25 degrees by 0.2 degrees step.

Up to 10 non-linear precorrection curves (10 AM-AM and 10 AM-PM tables) can be downloaded and saved into the equipment memory. For each curve a 10-characters name is associated. By using the local or remote control it is possible to disable the non-linear precorrection at all or activate one of the saved curves. Besides the 10 customizable curves, a non-customizable "Null" curve is always available: the AM-AM and AM-PM tables of this curve are filled by zeros.

1.4.5 LINEAR PRE-CORRECTION

Any output cavity filter will produce amplitude and group delay distortion over the ATSC 8-VSB signal

generated by the transmitter. Linear precorrection is used to exactly compensate these distortions in order to generate a signal which is maximally flat both in amplitude and group delay. The ATSC TRANSMITTER is able to perform amplitude and group delay correction over the full spectrum of the output signal.

The linear precorrection is a factory procedure, so the equipment is delivered with the optimal linear precorrection curve already operating.

By operating on the front panel user interface, the user may decide to switch off or switch on the linear precorrection curve stored by the Elettronika production department.

1.4.6 CONTROL OF THE EQUIPMENT

The ATSC TRANSMITTER can be controlled by means of a user-friendly LCD graphical interface with a single rotating knob for the menu navigation and for the selections or remotely through a RS232, RS485 or TELEMEASURES port. The functions of the local and remote control are:

- Setting the operating mode of the ATSC TRANSMITTER and the associated parameters. All these parameters are stored in a local memory, so the previous operating mode is automatically restored each time after a power cycle.
- Monitoring the status of the equipment.
- Recording events and alarms.
- Firmware upgrades.
- Digital Precorrection through RS232 port and dedicated PC software interface.

1.4.7 TEST MODES

Two test modes are available, to be used only for laboratory or field test. The test modes are directly accessible from the user menus and are:

- 1) *PRBS Sequence*: the ASI/SMPTE input signals are ignored and a 23-bit PRBS sequence replaces the input payload of the MPEG-TS packets. This test allows measurements on the modulated signal without the need of a valid ASI/SMPTE input signal.
- 2) *Single Tone*: the normal 8-VSB output spectrum is switched off and replaced by a sinusoidal output useful for frequency converters alignment.

Note: If test mode 2) is active, the ATSC TRANSMITTER does not generate a valid ATSC 8-VSB signal.

1.4.8 POWER HANDLING

After the ATSC TRANSMITTER is powered on, it starts radiating a valid ATSC 8-VSB signal within a short time. The maximum initial power-on delay is about 20s as factory default value. Any modification of this initial power-on delay is to be done with the support of the Elettronika Customer Service.

If a valid MPEG-TS signal is received over one of the ASI/SMPTE inputs, then the equipment will immediately generate the signal on the RF output. In absence of a valid MPEG-TS signal the equipment can be set to be muted or not.

Enabling the muting function is possible by the user menus, as explained in the Menu Management section of the present manual.

All the working parameters of the ATSC TRANSMITTER are stored into a non-volatile memory in the modulator section, so that there is no need to restore the parameters after a power off/on cycle.

The power handling is characterized by 3 states: MUTE, POWER UP and POWER ON.

- **MUTE** (POWER LED off, fan off): the internal amplifier is switched off by inhibiting the RF transistors gate.
- **POWER UP** (POWER LED blinking, fan on): the internal amplifier is switched on and the output power, starting from -3dB to the final level, is slowly increased following a linear ramp law.
- **POWER ON** (POWER LED on, fan on): the internal amplifier is switched on (normal working operation).

Moving from MUTE to POWER ON state (for example, after switching on or when an active alarm disappears) is performed by moving through a temporary POWER UP state. Instead, moving from POWER ON to MUTE state (for example, when a serious alarm occurs or the ASI/SMPTE inputs are corrupted or absent) is immediate.

1.4.9 ALARMS AND AUTOMATION

The ATSC TRANSMITTER is fully protected against any malfunctioning event that could damage the expensive internal components. *The user should clearly understand what happens in presence of alarms and warnings, in order to face these situations properly and reduce the inactivity time.*

In case of any alarm condition, the ALARM LED on the front panel lights up and a bell icon appears in the status bar of the display. When the alarm condition ceases, the ALARM LED is turned off and the bell icon starts blinking, in order to show that an anomaly occurred since the last visit to the log. To know the details about the alarm event (for example the time and date of its occurrence), the log menu can be used. Once the user enters the log screen, the bell icon disappears. When you note an active alarm (the bell icon is shown and not blinking and the ALARM LED

is on), go to the ALARM screen to see which alarms are present. For certain dangerous situations, the ATSC TRANSMITTER immediately switches off the output power, by acting on the RF power transistors gate, in order to save the internal parts from an unrecoverable damage. When the alarm disappears, the power is automatically switched on again. Once the output power has been inhibited for 5 times, the ATSC TRANSMITTER goes into "Lockout" state: the power remains off until the user resets the Lockout condition, or switches the equipment off for repair. After one hour from the last alarm and without the Lockout condition, the Lockout counter is automatically cleared. The list of the automatic interventions in case of anomalies can be found below.

● **Amplifier Voltage**

An amplifier power supply voltage alarm occurs when the monitored voltage is outside the nominal level $\pm 10\%$ range. The nominal voltage level is a factory setting (usually, 28V). This alarm *does not* trigger a powering off of the output signal. If the monitored voltage is near 0V, most probably the fuse located near the power amplifier stage is burned.

● **Amplifier Current**

An amplifier power supply current alarm occurs when the monitored current drained by the amplifier is 20% above the nominal level. The nominal current level is a factory setting. This alarm *does not* trigger a powering off of the output signal.

● **Amplifier Temperature**

The temperature is monitored on the hottest point, located near the power amplifier stage on the cooling heat sink. If the fans work well, and the ambient temperature is inside the working conditions limits, all of the internal parts should reach safe temperature levels. In some circumstances (for example, when a fan is blocked or damaged), the temperature may increase too much, and some internal components may break. In order to avoid this unpleasant situation, a temperature alarm occurs when the temperature is over a maximum threshold (75°C). This alarm triggers an immediate powering off of the output signal and an increase of the lockout counter.

The power will be switched on again only when the temperature goes below a second threshold, lower than the first (70°C).

● **Forward and Reflected Powers**

A forward or reflected power alarm occurs when the relevant monitored power level is over a threshold (factory setting). Both alarms trigger an immediate powering off of the output signal and an increase of the lockout counter.

You can see the levels of the power thresholds in the Amplifier menu (*see the **Menu Management** paragraph*).

● **Power supply voltages (+5V, +12V, -12V)**

Besides the amplifier power supply voltage (+28V), the ATSC TRANSMITTER uses three additional main voltages: +5V, +12V, -12V. These voltages are continuously monitored by the control system and any variation above 10% of the nominal value generates an alarm condition. This alarm *does not* trigger a powering off of the output signal.

● **No communication with the modulator**

The 8-VSB Modulator module continuously communicates with the control system. If this communication fails, the control board triggers a "No communication" alarm.

This is a serious malfunction that must be solved as soon as possible.

In presence of a no communication alarm, the control system is not able to know the working condition of the modulator (for example, the modulated output signal level), so it inhibits the power amplifier stage and the output power is brought to zero level.

- **External reference alarm**

When external or ASI/SMPTE reference is set, the modulator continuously monitors the presence of such reference. If it is not able to find a correct signal, it automatically switches to the internal reference. In this situation, an external reference alarm is triggered. This alarm *does not* trigger a powering off event. See the *Synchronization and Clocks* paragraph for more information.

- **ASI/SMPTE inputs alarm**

There are several conditions related to input streams that could trigger an alarm, depending on the working conditions. They are:

- MPEG-TS synchronization missing;
- uncorrected input packet (only in 204 RS coded mode with ASI input mode);
- bit rate underflow/overflow (only if bit rate adaptation is performed).

The above conditions trigger an alarm only for the input which is currently used by the ATSC TRANSMITTER.

1.4.10 AGC: IMPLEMENTATION AND DETAILS

The use of external AGC helps the ATSC TRANSMITTER to maintain stable the output power of a high-power transmitter. With a menu setting (*see the Menu Management paragraph*) you can choose among stabilizing the output power of the exciter (external AGC disabled) or stabilizing the output power of a high-power transmitter (external AGC enabled). In this case a proper cabling between the ATSC TRANSMITTER and the high-power amplifier stage is necessary. The cable (AGC cable) shall be connected to the TLM port of the ATSC TRANSMITTER on one side. In the following table the three signals and pins used in the TLM port are listed. The pinout connection of the cable depends on the specific amplifier used. Refer to your amplifier user's manual to find the port and pins of the corresponding signal.

PIN	I/O	DESCRIPTION
4	I	Forward Power (0-5V)
5	-	GND
8	I	Alarm (GND=Alarm / Open=Normal)

The AGC goal is to maintain the output power stable. Output power in fact can change due to the increase of the amplifier temperature. Note that when you change the operating frequency the output power changes due to the different gain at different frequency, but this change is not stabilized by the AGC algorithm. The transmitter power to be stabilized is read from TLM port.

To keep the power stable, the AGC changes the power gain of the ATSC TRANSMITTER.

The AGC algorithm is based on the acquisition of the optimal output power level, stored when you confirm the

output power level in the Power menu (*see the **Menu management** paragraph*) and the use of 4 thresholds as below:

_____ action threshold
_____ goal threshold
_____ optimal power value
_____ goal threshold
_____ action threshold

The distance of the thresholds from the optimal value is of $\pm 20\text{mV}$ and $\pm 30\text{mV}$ measured as monitor voltage. The AGC changes the output power to bring the power from the amplifier inside the goal thresholds range. When this goal is achieved, the AGC stops until the power goes outside the action thresholds range. The AGC is stopped immediately (output power remains blocked to the value reached at the moment in which the AGC stops) when one of the following conditions occurs:

- RF output is muted for an alarm condition or user setting;
- the AGC is chosen as external but the amplifier stage triggers an alarm;
- the ATSC TRANSMITTER output power is too low;
- the AGC has corrected the output power too much.

In order to simplify the understanding of the AGC behaviour, the status of the external AGC is written in the Power menu (Ext AGC Status parameter). The possible statuses of the AGC are listed below.

- *Disabled*: external AGC is disabled.
- *Idle*: external AGC is stopped (for example, during the slow increase of the power immediately after switching on the equipment).
- *Low Set*: external AGC is stopped because external power reading was too low when the nominal output power has been chosen.
- *Alarm*: external AGC is stopped because an alarm signal from the power amplifier stage is active.
- *Locked*: the transmitter output power has reached the desired level.
- *Max/Min*: external AGC is stopped because the power correction is too high.
- *Pull Up/Down*: external AGC is moving the power level up or down.

Warning! When changing from AUTO to MANUAL power control mode, the external AGC will be disabled.

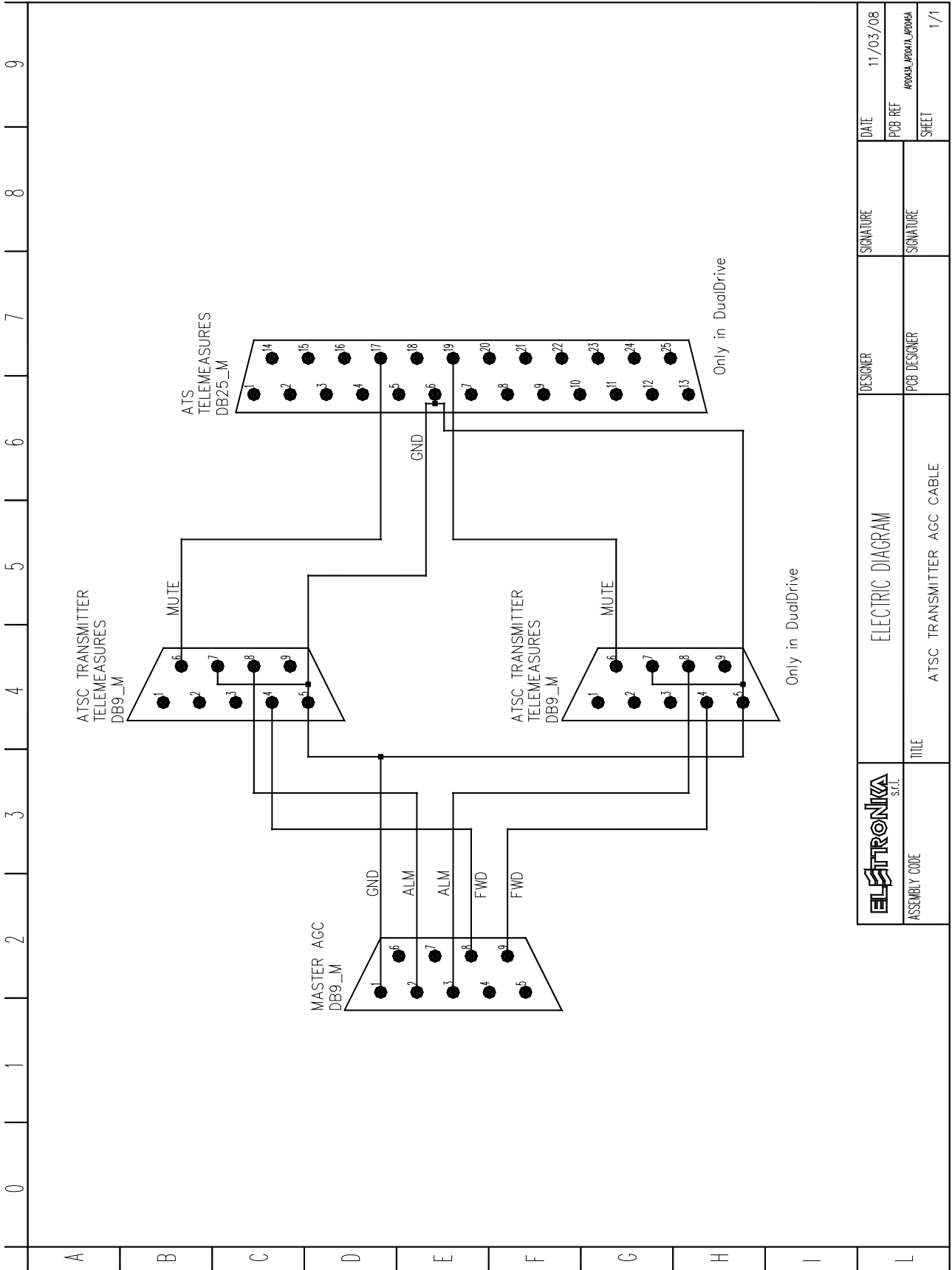

	ELECTRIC DIAGRAM		DESIGNER	SIGNATURE	DATE	11/03/08
	TITLE		PCB DESIGNER	SIGNATURE	PCB REF	AP004A_AP004A_AP004A
	ATSC TRANSMITTER AGC CABLE				SHEET	1/1

1.14.11 LOG

The ATSC TRANSMITTER is provided with an internal non-volatile memory used to store up to 200 events in a log. For each event, the date, time and a description are stored in order to help the user in understanding the sequence of the events and the cause of each alarm.

The log can be viewed locally on the display (*see the LOG screen in the Menu Management paragraph*) or by remote. It is possible to clear the log contents only locally.

The events are organized from the last one: the first event in the log is the last that happened. The second is the previous event compared to the first, and so on.

When the log is full (i.e., 200 events are stored), the new events will replace the older ones, like in a FIFO (first in/first out) queue.

The type of events that can be stored in the log are:

- Power supply on from mains voltage
- Mute settings (automatic/manual) changed
- Remote/local control changed
- Lockout
- Amplifier voltage alarm
- Amplifier current alarm
- Forward power alarm
- Reflected power alarm
- Temperature alarm
- Power supply voltage (-12V, +12V or +5V) alarm
- Modulator no communication alarm
- External reference alarm
- ASI/SMPTE inputs related alarms

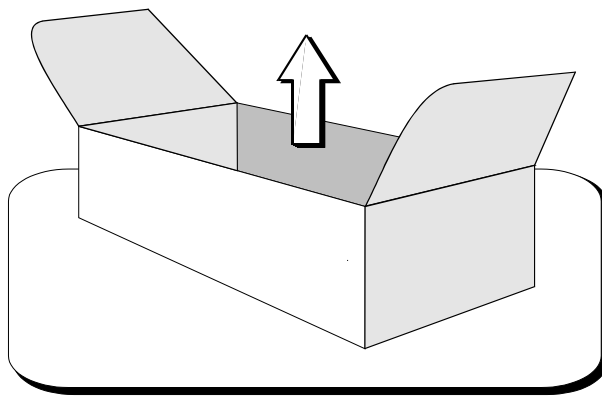

Section 2 - Installation

Contents:

- 2.1 Operating environment*
- 2.2 First installation*
- 2.3 ATSC TRANSMITTER with GPS Clock Source*
- 2.4 ATSC TRANSMITTER remote control with Eletronika RCU*
- 2.5 ATSC TRANSMITTER with PC*

2.1 OPERATING ENVIRONMENT

You can install the apparatus in a standard component rack or on a suitable surface such as a bench or desk. In any case, the area should be as clean and well-ventilated as possible. Do not locate the transmitter directly above a hot piece of equipment.

2.2 FIRST INSTALLATION

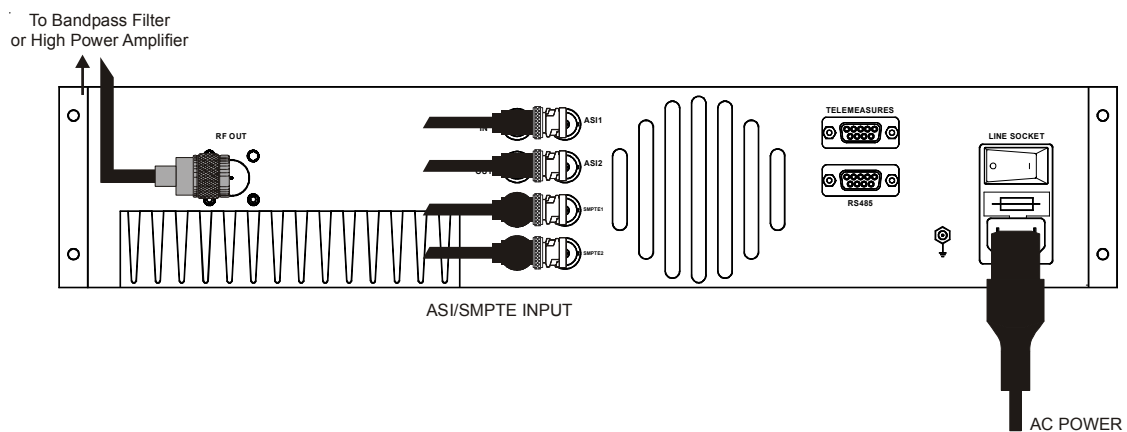

Correct installation of the equipment is important for maximum performance and reliability. Antenna and earth connections must be installed with the greatest care. No equipment adjustment is needed, because the unit is completely adjusted by our technical staff. This is the installation procedure:

1. Connect Antenna cable.
2. Connect AC POWER cord.
3. Connect the ASI/SMPTE Inputs you want to use depending on the operating mode (hierarchical or non hierarchical) and available auxiliary inputs (*see the table in **Input Management** paragraph*).
4. Move power slowly up till nominal power and check the Reflected Power to be low. If the Reflected Power increases check the RF Output connections.

2.3 ATSC TRANSMITTER WITH GPS CLOCK SOURCE

1. Connect the 10MHz reference only for higher stability or frequency locking purposes
2. The 1PPS signal is not used for ATSC operation, so leave this output not connected.

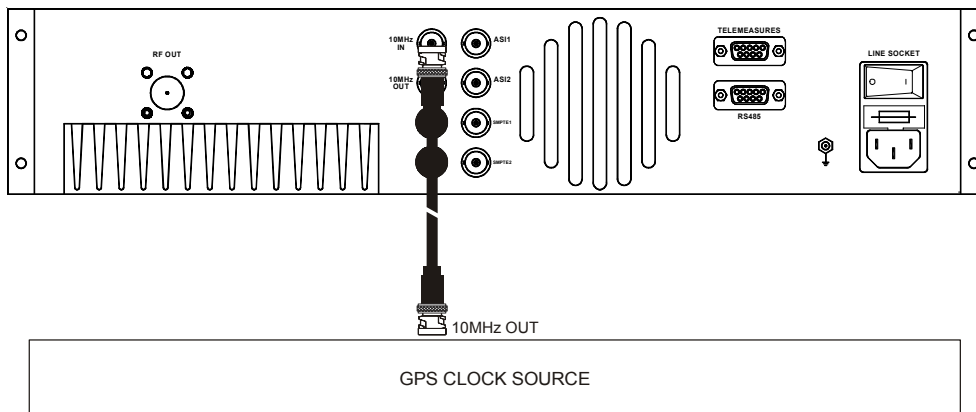

2.4 ATSC TRANSMITTER REMOTE CONTROL WITH ELETTRONIKA RCU

In order to connect the ATSC TRANSMITTER to RCU the RS485 connector must be used and RS485 must be chosen in the ATSC TRANSMITTER menu (Setup → Control → Serial).

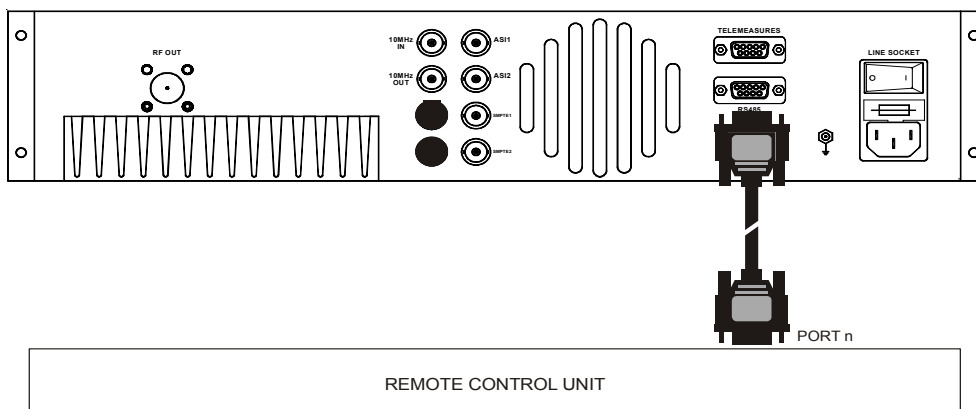

2.5 ATSC TRANSMITTER WITH PC

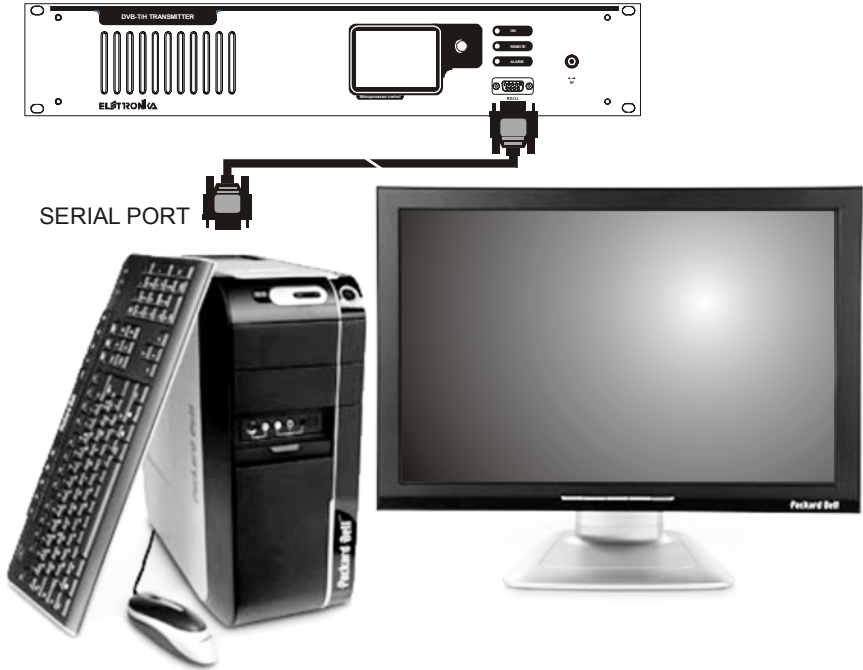

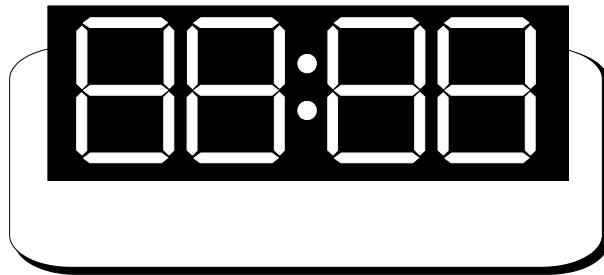

Section 3 - Operation

Contents:

- 3.1 Local Control*
- 3.2 LEDs*
- 3.3 Menu Management*
- 3.4 Parameters and Menu description*
- 3.5 Log Screen*
- 3.6 Alarm Screen*
- 3.7 Firmware Upgrade*
- ATSC TRANSMITTER Menu Map*

3.1 LOCAL CONTROL

A large number of options of the ATSC TRANSMITTER can be easily and intuitively controlled through the human-to-machine interface on the right side of the front panel. This is composed by a graphic display, a clickable knob and three LEDs.

Right after switching on, a screen showing the initialization process appears on the display. During this time the controller checks the good communication among internal parts of the equipment.



3.2 LEDs

Near the display three status LEDs allow to gather information concerning the general status of the system without having to look at the display.

Their meaning is explained in the table below.

LED	COLOUR	DESCRIPTION
ON	Green	The ON LED is lit when the power is on. It blinks during the power increase stage. It is off if the output is muted (see the Power handling paragraph)
REMOTE	Yellow	The REMOTE LED is lit when the remote control is enabled
ALARM	Red	The ALARM LED lights up if some alarm is active

3.3 MENU MANAGEMENT

After the initialization screen, the DIAGRAM screen is shown on the display. It represents a simple diagram of the machine: ASI/SMPTE inputs, the ATSC modulator, the up-converter and the amplifier. The most important parameters are also shown in this screen. Pressing the knob while in this menu you will be directed to the RF Power menu for a quick intervention during emergency situations.

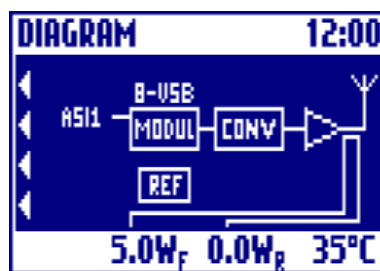

3.3.1 TITLE BAR

On the top of the display, the title bar is shown. It is always visible during browsing the various menus and screens. In the bar two pieces of information are present.

- The name of the screen is displayed on the left (DIAGRAM in the case of the first screen). During settings change, a confirmation question could appear in this part of the titlebar (see later).
- The actual time is on the right side of the bar. The colon symbol between hours and minutes blinks every second in order to indicate the progress of time.

3.3.2 STATUS BAR

On the bottom of the display, the status bar is shown. It is always visible while browsing the various menus and screens. In the bar five pieces of information are present, as described in the following list (the order is from the left to the right of the bar).

- The bell icon (🔔) on the left gives the user some information about alarm conditions that are present or that occurred in the past. The icon can be absent, present or blinking. The meanings of these conditions are detailed in the following table.

ICON	DESCRIPTION
Absent	No alarms are present and no alarms occurred since the last visit to the log
Present	At least an alarm is present at the moment
Blinking	An alarm occurred since the last visit to the log, but no alarm is present at this moment

-
- The lock icon (🔒) at the right of the bell icon is displayed when the control is password-locked (see later in this manual for more information about password locking). When the user unlocks it by typing the correct password, the lock icon disappears.
 - The Forward Power is shown about at the centre of the status bar. It is indicated in Watt. This is the power as it is measured by the directional coupler at the very last stage of the power amplifier, just before the output connector. When the RF is muted, the word MUTE is shown instead of the output power.
 - The Reflected Power is shown next to the Forward Power. It is indicated in Watt. This is the power as it is measured by the directional coupler at the very last stage of the power amplifier, just before the output connector. When the RF is muted, the word MUTE is shown instead of the Reflected Power.
 - The Temperature is shown at the rightmost side of the status bar. It is indicated in Centigrade degrees. This temperature is measured by a sensor located near the hottest spot of the cooling heat sink of the power amplifier stage. When a temperature alarm is present (the temperature is over the threshold), the temperature indication in the status bar blinks.

3.3.3 DIAGRAM SCREEN

The DIAGRAM screen represents a general schematic view of the ATSC TRANSMITTER. The most important working settings are written using a small-size font. By looking at this diagram, the user can have a general overview of the equipment status.

On the left there is the input section, showing ASI1/ASI2 or SMPTE1/SMPTE2 depending on the selection made in INPUT → CONFIGURATION menu. In ASI mode, the upper ASI1 text appears when a valid ASI1 input stream is present. The lower ASI2 text appear when a valid ASI2 input stream is present. These words blink if a bad input stream is detected. The behaviour is identical in SMPTE mode with a difference only in the strings: SMPTE1 and SMPTE2 instead of ASI1 and ASI2.

The presence of the string indicates only the presence of a corresponding input stream. The actual input stream used by the modulator is shown by a horizontal line starting from the input name and entering the modulator.

Next to the input section, the modulator block is drawn. On top of the rectangle, the ATSC mode is written: 8-VSB. The word MODUL blinks if any error associated to the modulator is present.

At the bottom of the modulator rectangle, there is the external reference block. If a valid reference is detected, the REF rectangle is drawn. If the external reference is actually used by the modulator, a vertical line connect the REF to the MODUL rectangles. If the user choose to use the external reference, but a good reference can't be detected, the REF rectangle blinks.

Immediately on the right, the up-converter block is drawn. On top of the rectangle, the RF channel number is written if the frequency is chosen by standard/channel couple. Nothing appears if the frequency is set manually. The triangle on the right represents the power amplifier and an hypothetical antenna connected to it. From the output of the power amplifier, two lines start: they indicates the output power and the reflected power measures shown in the status bar at the bottom of the display.

3.3.4 BROWSING THE MENUS AND PARAMETERS

The user can browse the menus, see the parameters values, change the settings of the machine and make all the operations simply by using the knob located on the right of the display. The knob can be rotated left or right and be pushed.

From the first screen (DIAGRAM screen), it is possible to rotate the knob to the left to enter the MAIN MENU screen.



In this screen six icons (INPUT, MOD, RF, SETUP, LOG, ALM) are shown, arranged in 2 lines of 3 icons. The selected icon is drawn in reverse colours. By moving from the DIAGRAM screen, the selected icon will be ALM, as in figure above. It is possible to select the other icons by rotating the knob again to the left. By rotating the knob to the right, it is possible to select the icons in the opposite order. When the ALM icon is selected, rotate the knob to the right to go back to the DIAGRAM screen again.

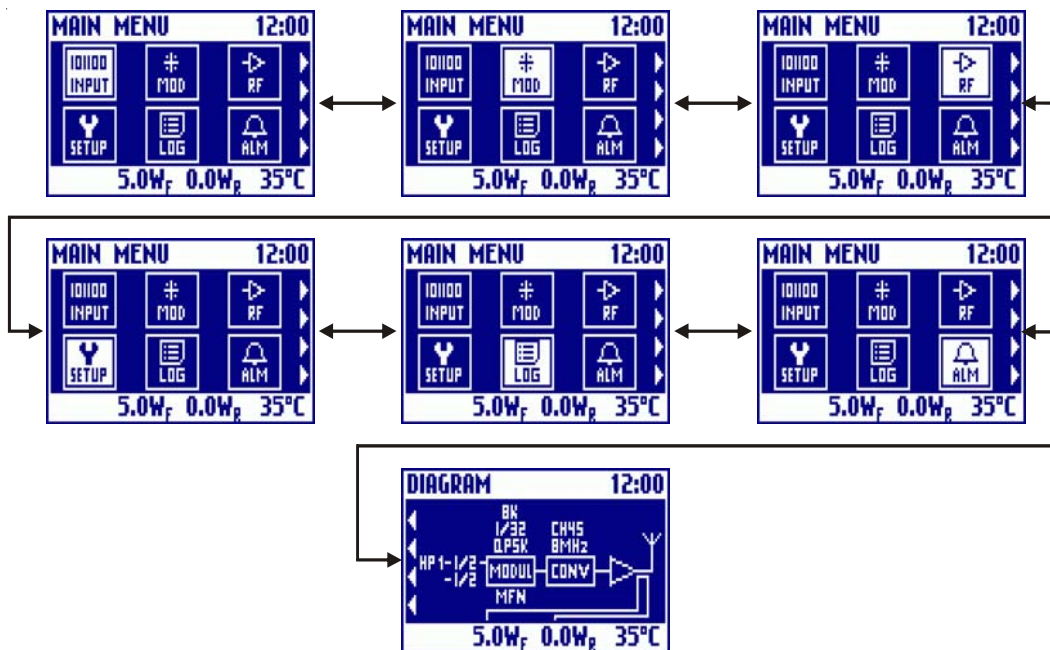

When an icon is selected, click the knob to enter the associated menu. For example, by clicking the knob when the RF icon is selected, the menu related to the RF signal is shown.

The ATSC TRANSMITTER is a complex piece of equipment and its setting could be a difficult task. The multitude of parameters are arranged in six tree-like menus, starting from the six top-level menu icons. In this way, it is simpler and more comfortable to find the desired parameter.

3.3.5 COMPOSITION OF A MENU

An example menu (the RF menu) is depicted in the figure below.



The title of the menu (RF in this example) is written at the leftmost side of the titlebar. Every menu is composed by several items, but only four of them are shown at the same time on the display. The first item is always “Exit...”. One of the item is selected and is shown in reverse colours. By rotating the knob to the right (bottom), the selected item is changed and the menu is scrolled down to its last item. By rotating the knob to the left (up), the menu is scrolled up to its first item. The scrollbar drawn on the left of the items gives an idea about the selected item position in the menu: the position of the small tab inside the scrollbar changes depending on the selected item, from the top to the bottom of the outer rectangle representing the bar. There are 3 types of item in a menu, characterized by a different suffix appended to the item name:

- *submenus*, with leading dots (☰);
- *read/write parameters*, with a right arrow (➤) suffix;
- *read-only parameters*, without any suffix.

In case of failure, the value of the failed parameter (read/write or read-only) blinks to show the malfunction, until the alarm condition disappears. If the “Modulator no communication” alarm is present, the value of parameters related to the modulator is indicated as “???”.

- *Submenus*

A submenu item is indicated by the name of the submenu and the leading dots. By clicking on a submenu (e.g., by clicking the knob when a submenu item is selected), a new child menu is shown, browsing the tree-like

menu from the top to the bottom. As before, this new (sub) menu is composed by several items that can be other submenus or parameters.

Even if it has leading dots, the “Exit...” item, the first item of all menus, isn’t a real submenu. By clicking on “Exit...”, it goes back to the parent menu, if any, browsing the tree-menu from the bottom to the top. If the menu is at the top-level, by choosing “Exit...” the menu icons screen is shown.

- Read/write parameters

The row of a read/write parameter is composed by two parts: the leftmost one contains the name of the parameter with arrow suffix, the rightmost one contains its value or an “action symbol”.

By clicking on a read/write parameter, the associated value is written in reverse colours, meaning that it is possible to change it by rotating the knob. Some parameters can be changed continuously in a range (e.g., the output power level); move the knob to the right (left) to increase (decrease) the value. For other parameters, the value can be chosen from a short list (e.g., the input selection); move the knob to the right (left) to scroll down (up) the list. For some other complex parameters, like the frequency or the date, the user can change a token at a time (a digit of the frequency, a field of the date) by rotating the knob, moving to the next token by clicking on the knob.

After choosing the desired new value, click the knob to finish the change. Usually, until now, no real change of the parameter took place (there are some exceptions, well described later). It is necessary to accept the new value by rotating the knob to the right in order to choose the answer “Yes” to the confirmation question (“Sure?”) that appears at the left of the titlebar. By answering “No” to the confirmation question, the new value is discarded and the parameter keep the old value.



There are some “special” read/write parameters that represent only an action to make (e.g., Clear Log). Their value is shown with the  symbol. By clicking on this kind of parameter, the symbol is drawn in reverse colours. Click again and choose “Yes” to the confirmation question in order to perform the associated action (e.g., clearing the log content). It should be noticed that, if the control is password-locked or the remote control is enabled, a read/write parameter could become a read-only parameter until the control is unlocked by typing the correct password or the remote control is disabled.

- Read-only parameters

The row of a read-only parameter is composed by two parts: the leftmost contains the name of the parameter, the rightmost one contains its value. The user can read this value, but not modify it. In fact, if clicking on a read-only parameter, nothing happens.

3.4 PARAMETERS AND MENU DESCRIPTION

This paragraph contains a detailed description of all the menus and parameters. Please be sure to read this section very carefully before changing any setting of the exciter. Check the menu map for a general overview of the parameters.

The menus and parameters arrangement is subject to change, mostly with the control firmware version. Your arrangement could be slightly different than the one described in this manual. For any questions, contact the Elettronika Customer Service.

3.4.1 INPUT MENU

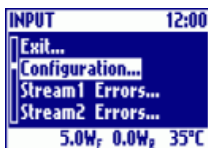

Configuration

Click on this item to enter the Configuration submenu to read and/or modify the inputs (ASI/SMPTE, external 10MHz reference) settings.

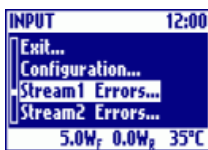

Stream1 Errors

Click on this item to enter the Stream1 Errors submenu to read the actual errors present in the Stream1 (see the *TS Input Management* paragraph for more information about Stream1 meaning in hierarchical and non-hierarchical mode).

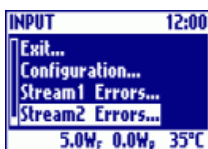

Stream2 Errors

Click on this item to enter the Stream2 Errors submenu to read the actual errors present in the Stream2 (see the *TS Input Management* paragraph for more information about Stream1 meaning in hierarchical and non-hierarchical mode).

- Configuration Submenu



10MHz refer. (Int, Ext, ASI)

This parameter shows the 10MHz reference source selection set by the user (Int, Ext, TS).

In case it is Ext or TS and if the chosen reference is absent, the modulator automatically uses the internal reference. This is shown in parentheses.

By clicking on this item, the user can change the 10MHz reference source.

Please, check the *Synchronization and Clocks* paragraph for more information about the input reference stage of the modulator.

INPUT CONFIG 12:00	
Exit...	
Input ▶	ASI1
10MHz refer. ▶	Int
10MHz input	Present
5.0W _F 0.0W _P 35°C	

10MHz input (Present, Absent)

This is a read-only parameter that indicates the presence or absence of the external 10MHz reference. Please, check the *Synchronization and Clocks* paragraph for more information about the input reference stage of the modulator.

INPUT CONFIG 12:00	
10MHz input	Present
LoR Mute ▶	ON
LoR Timeout ▶	00h30'
ASI1 sync	Present
ASI1 sync	Present
5.0W _F 0.0W _P 35°C	

ASI1 sync (Present, Absent)

If a valid ASI1 input is detected by the modulator, the word Present is written. On the contrary, if no ASI1 input is detected by the modulator, the word Absent is written.

INPUT CONFIG 12:00	
LoR Mute ▶	ON
LoR Timeout ▶	00h30'
ASI1 sync	Present
ASI2 sync	Absent
ASI2 sync	Absent
5.0W _F 0.0W _P 35°C	

ASI2 sync (Present, Absent)

If a valid ASI2 input is detected by the modulator, the word Present is written. On the contrary, if no ASI2 input is detected by the modulator, the word Absent is written.

INPUT CONFIG 12:00	
LoR Timeout ▶	00h30'
ASI1 sync	Present
ASI2 sync	Absent
SMPTE1 sync	Absent
SMPTE1 sync	Absent
5.0W _F 0.0W _P 35°C	

SMPTE1 sync (Present, Absent)

If a valid SMPTE1 input is detected by the modulator, the word Present is written. On the contrary, if no SMPTE1 input is detected by the modulator, the word Absent is written.

INPUT CONFIG 12:00	
ASI1 sync	Present
ASI2 sync	Absent
SMPTE1 sync	Absent
SMPTE2 sync	Absent
5.0W _F 0.0W _P 35°C	

SMPTE2 sync (Present, Absent)

If a valid SMPTE2 input is detected by the modulator, the word Present is written. On the contrary, if no SMPTE2 input is detected by the modulator, the word Absent is written.

INPUT CONFIG 12:00	
Input ▶	ASI1
10MHz refer. ▶	Int
10MHz input	Present
LoR Mute ▶	ON
5.0W _F 0.0W _P 35°C	

LoR Mute (ON, OFF)

When the external reference is absent, it is possible to automatically mute the output after a configurable timeout. By choosing ON, the automatic mute on lost of reference feature is enabled. Set this parameter to OFF to not mute the output on lost of reference.

INPUT CONFIG 12:00	
10MHz refer. ▶	Int
10MHz input	Present
LoR Mute ▶	ON
LoR Timeout ▶	00h30'
5.0W _F 0.0W _P 35°C	

LoR Timeout (00h00'-24h00)

It's the timeout the transmitter waits before muting the output on lost of reference. If the LoR Mute parameter is OFF, the timeout is ignored. Set the timeout to 0 to immediately mute the output on lost of reference.

- Stream1 Errors Submenu



MPEG sync (Present, Absent)

If Absent is written, no MPEG sync is detected.



Uncorrected Pkt (No, Yes)

If this parameter is Yes, incorrect input packet is detected (only in 204 RS coded input mode).



Bitrate mismatch (No, Yes)

If this parameter is Yes, a bitrate overflow or underflow condition is present (only if bitrate adaptation is not performed).



PCR Rate (No, Yes)

If Err is shown, no PCR is detected over 10 seconds or PCR interval error.

- Stream2 Errors Submenu



MPEG sync (Present, Absent)

See the same parameter for Stream 1.

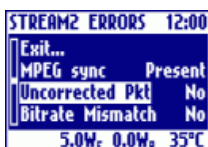

Uncorrected Pkt (No, Yes)

See the same parameter for Stream 1.



Bitrate mismatch (No, Yes)

See the same parameter for Stream 1.



PCR Rate (No, Yes)

See the same parameter for Stream 1.

3.4.2 MODULATION MENU

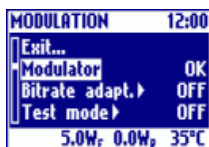

MODULATOR (OK, Err, No Comm)

If the ATSC Modulator module is correctly working, this read-only parameter shows OK. If the modulator has an internal error or it doesn't communicate with the control board, it shows "Err" or "No Comm".

Warning! If this parameter isn't OK, a serious malfunction of a core part of the ATSC TRANSMITTER is present. Be sure to solve this problem before installing the equipment at the final destination.

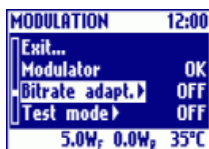

Bitrate adapt. (OFF, ON)

If this parameter is set to ON, the bitrate is adapted. If it is set to OFF, the bitrate is not adapted.

See the *TS Input Management* paragraph for more information.

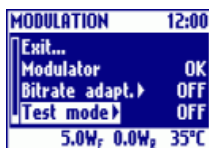

PRBS (OFF, PRBS, Sinus)

With this parameter it is possible to activate the PRBS or Single Tone test mode (see the *Test Modes* paragraph for more information about the available test modes).

3.4.3 RF MENU

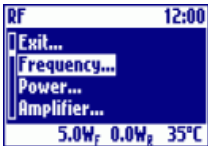

Frequency

Click on this item to enter the Frequency submenu to read and/or modify the centre frequency and the bandwidth of the output signal.

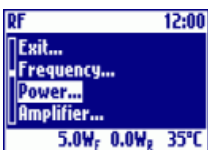

Power

Click on this item to enter the Power submenu to control the output power level and to configure the AGC (see the *AGC: Implementations and Details* paragraph for more informations).

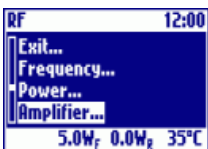

Amplifier

Click on this item to enter the Amplifier submenu to read the internal amplifier status and to reset the lockout condition (see the *Alarms and automations* paragraph for more informations).

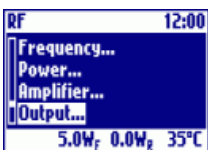

Output

Click on this item to enter the Output submenu to read and/or modify some settings related to the output signal and to the mute configuration.

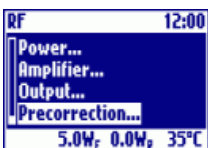

Precorrection

Click on this item to enter the Precorrection submenu to read and/or modify the precorrection configuration.

- Frequency Submenu

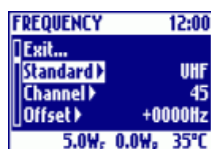

Standard ([User], UHF, VHF)

The user can set the output signal frequency by choosing Standard/Channel pair or by setting a custom frequency. At the time of printing this manual, the available standards are UHF and VHF. Others may be available with future firmware releases.

When a custom frequency is set instead, User appears as the standard and channel and the channel offset is reset.



Channel (depending on the selected standard)

The user can set the output signal frequency by choosing Standard/Channel pair or by setting a custom frequency. At the time of printing this manual, the available standards are UHF and VHF. Others may be available with future firmware releases. The channels that can be chosen depend on the selected standard (for example, if UHF standard is selected, channel can be changed in the 14-69 interval). When a different standard is chosen (for example, from VHF to UHF), the first channel (in the example, 14) is automatically set. When a custom frequency is set instead, User appears as the standard and channel and the channel offset is reset.



Channel Offset (-9999÷+9999Hz by 1Hz step)

If the frequency is set by using Standard/Channel pair, it is possible to finely adjust the center frequency, by setting this parameter. The offset can be negative and positive.



Freq (57÷860MHz by 1Hz step)

The user can set the output signal frequency by choosing Standard/Channel pair or by setting a custom frequency. The digits of the frequency can be changed one at a time in the 0-9 range (only the first digit can be changed in the 1-8 range). Click on the knob to move to the next digit. If a value lower than 57MHz (greater than 860MHz) is set, the frequency 57MHz (860MHz) will be used instead.

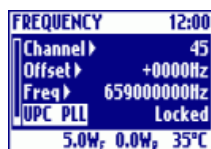

UPC PLL (Locked, Unlocked)

This read-only parameter shows the status of the up-converter PLL. It can be Locked or Unlocked.

- Power Submenu



Power Control (Manual, Auto)

This parameter sets the power control mode as either automatic (AGC) or manual. See the **AGC: Implementation and details** paragraph for more information.

Warning! For safety operation it is better to set to 0% the power level that is not selected. For example, if the automatic power control mode is selected, it is better to set the manual power level to 0%. This way, after changing from automatic to manual, the output power will safely starts from zero level.



Pwr Level Man (0÷100%)

This parameter sets the operating level of the output power, if manual power control mode is selected. Rotate the knob to increase/decrease the level in the 0÷100% range. If the user makes a *fast left rotation with a single movement*, the power automatically goes down to 0%. If the user rotates the knob to the right, the autodecrement will be blocked.

See the **AGC: Implementation and details** paragraph for more information.

Note that, differently from the usual read/write parameters, when you rotate the knob the change is immediately active. When you reach the desired value indicated on the display status bar, click on the knob and choose “Yes” to answer the confirmation question in order to accept the new power level. Choose “No” to ignore the new and restore the old level.



Pwr Level Auto (0÷100%)

This parameter sets the operating level of the output power, if automatic power control mode is selected. Rotate the knob to increase/decrease the level in the 0÷100% range. If the user makes a *fast left rotation with a single movement*, the power automatically goes down to 0%. If the user rotates the knob to the right, the autodecrement will be blocked. See the **AGC: Implementation and details** paragraph for more information.

Note that, differently from the usual read/write parameters, when you rotate the knob the change is immediately active. When you reach the desired value, click on the knob and choose “Yes” to answer the confirmation question in order to accept the new power level. Choose “No” to ignore the new and restore the old level.



Ext AGC (Disabled, Enabled)

You can enable/disable the external AGC by changing the value of this parameter. *Please, be sure to deeply understand the AGC implementation details, before changing this parameter value.* See the **AGC: Implementation and details** paragraph for more information.

POWER	12:00
Pwr Level Man ▶	19%
Pwr Level Auto ▶	0%
Ext AGC ▶	Disabled
↳Status	---
5.0W _F 0.0W _F 35°C	

Ext AGC Status (—, Idle, Locked, Lowset, Alarm, Max, Min, Pull-up, Pull-down)

This read-only parameter shows the current status of the external AGC that can be one of the following:

- —: the external AGC is disabled;
- Idle: the external AGC is stopped (e.g., right after switching on, before the output power reaches the nominal level);
- Low Set: the external AGC is stopped because external power reading was too low when the output power was set;
- Alarm: the external AGC is stopped because an Alarm signal from external power amplifier is detected;
- Locked: the external AGC has reached the desired power level;
- Max/Min: the external AGC is stopped because the correction is too high;
- Pull up/down: the external AGC is moving up or down the driving power level.

See the *AGC: Implementation and details* paragraph for more information.

- Amplifier Submenu

AMPLIFIER	12:00
Exit...	
V	28.0V
I	6.0A
Lockout	Absent
5.0W _F 0.0W _P 35°C	

V

This is a read-only parameter that shows the voltage of the RF amplifier stage, measured in Volt. If this value is outside the normal range, an alarm occurs and the value on the display blinks.

AMPLIFIER	12:00
Exit...	
V	28.0V
I	6.0A
Lockout	Absent
5.0W _F 0.0W _P 35°C	

I

This is a read-only parameter that shows the current absorbed by the RF amplifier stage, measured in Ampere. If this value is outside the normal range, an alarm occurs and the value on the display blinks.

AMPLIFIER	12:00
Exit...	
V	28.0V
I	6.0A
Lockout	Absent
5.0W _F 0.0W _P 35°C	

Lockout (Present, Absent)

This read-only parameter shows whether the lockout condition is present or absent. In case of presence of lockout, the label blinks (see the *Alarms and automation* paragraph for more information).

AMPLIFIER	12:00
Exit...	
V	28.0V
I	6.0A
Lockout	Absent
Reset Lockout	↵
5.0W _F 0.0W _P 35°C	

Reset Lockout

This is an “action” parameter that allows to reset the lockout condition. If the lockout isn’t present, nothing happens (see the *Alarms and automation* paragraph for more information).

AMPLIFIER	12:00
I	6.0A
Lockout	Absent
Reset Lockout	↵
Fwd max	6.0W
5.0W _F 0.0W _P 35°C	

Fwd max

This parameter indicates the threshold of the output power. If the output power is higher than this threshold, an alarm occurs (see the *Alarms and automation* paragraph for more information).

AMPLIFIER	12:00
Lockout	Absent
Reset Lockout	↵
Fwd max	6.0W
Ref max	0.6W
5.0W _F 0.0W _P 35°C	

Ref max

This parameter indicates the threshold of the reflected power. If the reflected power is higher than this threshold, an alarm occurs (see the *Alarms and automation* paragraph for more information).

- Output Submenu



Spectrum (Normal, Inverted)

This parameter enables or disables the spectrum inversion.



RF Mute (Auto, ON)

If you set this parameter to ON, the output is muted. If Auto is set, the output can be muted depending on some conditions. In this case, the current mute status is shown in parenthesis.



Mute on In. Err (ON, OFF)

If this parameter is set to ON, the output will be automatically muted whenever an error on ASI inputs occurs (for example if the inputs are absent). If it is set to OFF, errors on ASI inputs don't affect the output muting.



Mute Type (Fast, Slow)

This parameter sets the mute type. If Fast is set, the mute will be direct (abrupt muting). If Slow is set, the mute will be progressive.

- Precorrection Submenu



Linear Precorrection (ON, OFF)

The linear precorrection feature can be enabled/disable by setting this parameter. See the *Linear Precorrection* paragraph for more information.



Non lin (ON, OFF)

With this parameter it is possible to change the non-linear precorrection behaviour of the modulator. If it is set to OFF, the non-linear precorrection is disabled. If it is set to Null, the non-linear precorrection is enabled, but a “null curve” is used. Other non-linear precorrection curves, up to 10, each characterized by a different name, could be stored inside the controller. In this case, the user can select one of them.

See the *Non Linear Precorrection* paragraph for more information.

3.4.4 SETUP MENU



Control

Click on this item to enter the Control submenu to configure the remote control and the password locking.



Log Clear

This is an “action parameter” and it is used to clear the log content. Be sure to read the latest events before clearing the log. After clearing, it isn’t possible to undelete the events.



Factory Settings

During the test phase of the machine, most of all parameters and adjustments are well defined and saved in a non-volatile memory. The user can retrieve and load this configuration by clicking on Factory Settings item menu. Note that after loading the factory settings, many parameters are changed simultaneously at one time. Please, use this feature with care.



Display

Click on this item to enter the Display submenu to read and/or modify the backlight and contrast of the LCD.



Clock

Click on this item to enter the Clock submenu to read and/or change the actual time.



Power Supply

Click on this item to enter the Power Supply submenu to monitor the power supply voltages status.



Versions

Click on this item to enter the Versions submenu to read all the firmware versions.

- Control Submenu



Control (Local, Remote)

The ATSC TRANSMITTER is fully-controllable locally (by using the display and the knob) or by remote (by using RS232/RS485 serial ports). With this parameter it is possible to set local control or remote control. When local control is selected, only reading commands from remote will be answered, while writing commands will be denied. In this case, changing of settings is possible only locally. If remote control is selected, it will be possible to read the status locally (display) and from remote (RS232, RS485), but changing of settings will be possible only by remote. In this case, many parameters will become as read-only type on the display.



Serial (RS232, RS485)

The remote control can be performed by using a serial port (RS232 or RS485) or a parallel port (TELEMEASURES). While TELEMEASURES port is always enabled, only one of the two serial ports must be enabled at any time, because they are mutually exclusive. If you don't use remote control, don't care about this parameter.



TLM out (Alarm, Squelch)

The meaning of the digital output of TLM port (pins 6 and 7) can be changed by the user in two different modes: Alarm (useful to interface a custom remote control system) and Squelch (useful to interface a switchover control system).



Password

In order to prevent an unauthorized user from changing the settings of the machine, it is possible to lock the control by inserting a 5-digits password. When the control is unlocked, the word "Unlocked" is written as parameter value. Click on this parameter and set a digit at a time. After changing the last digit and answering "Yes" to the confirmation question, the control is locked and the word "Locked" appears (the lock symbol is visible on the status bar too). Now, the user can't change any setting by using the knob and display. However, they can continue monitoring the status of the equipment by browsing the menus. Most of the parameters become as read-only type. When the control is locked, click on this parameter to insert the same 5-digits password used to lock. If the password is correct, the control will be unlocked, otherwise the control remains locked.

Contact the Elettronika Customer Service if you forget the password.

- Display Submenu



Backlight (0÷100%)

The graphical LCD has a white-LED backlight. Its intensity can be changed by software using this parameter. Differently from usual parameters, the modification immediately takes place when the user rotates the knob. When you reach the desired intensity level, click on the knob and reply “Yes” to the confirmation question to accept the new value. If you reply “No”, the value set before entering the parameter is restored. If the user doesn’t use the knob for more than 1 minute, the display backlight is automatically switched off. Click or move the knob to switch the LCD backlight on. The knob action (clicking or moving) that switches on the backlight isn’t used for menu and parameters browsing/settings.



Contrast (0÷100%)

As well as the backlight, the display contrast can be changed by software using this parameter. Differently from usual parameters, the modification immediately takes place when the user rotates the knob. When you reach the desired contrast level, click on the knob and reply “Yes” to the confirmation question to accept the new value. If you reply “No”, the value set before entering the parameter is restored.

- Clock Submenu

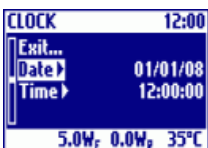

Date (dd/mm/yy)

With this parameter it is possible to see and change the date stored in the control board. It is shown in the dd/mm/yy format (dd=day of the month, mm=month, yy=year).
Be sure to set the correct date because it will be stored with log events.

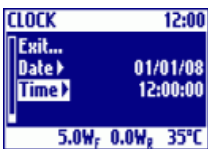

Time (hh:mm:ss)

With this parameter it is possible to see and change the current time stored in the control board. It is shown in the hh:mm:ss format (hh=hours, mm=minutes, ss=seconds).
Be sure to set the correct time because it will be stored with log events.

- Power Supply Submenu

POWER SUPPLY	12:00
Exit...	
+5V	+5.0V
+12V	+12.0V
-12V	-12.0V
5.0W _F 0.0W _F 35°C	

+5V

This read-only parameter shows the +5V power supply voltage monitored by a voltage sensor. If this voltage is outside a reasonable range, an alarm occurs and the value starts blinking on the display (see the *Alarms and automation* paragraph for more information).

POWER SUPPLY	12:00
Exit...	
+5V	+5.0V
+12V	+12.0V
-12V	-12.0V
5.0W _F 0.0W _F 35°C	

+12V

This read-only parameter shows the +12V power supply voltage monitored by a voltage sensor. If this voltage is outside a reasonable range, an alarm occurs and the value starts blinking on the display (see the *Alarms and automation* paragraph for more information).

POWER SUPPLY	12:00
Exit...	
+5V	+5.0V
+12V	+12.0V
-12V	-12.0V
5.0W _F 0.0W _F 35°C	

-12V

This read-only parameter shows the -12V power supply voltage monitored by a voltage sensor. If this voltage is outside a reasonable range, an alarm occurs and the value starts blinking on the display (see the *Alarms and automation* paragraph for more information).

- Versions Submenu

VERSIONS	12:00
Exit...	
Control	2.02
Modulator HW	1.01
Modulator SW	1.00
5.0W _F 0.0W _F 35°C	

Control

This is the control system version of the ATSC TRANSMITTER. It is composed by two numbers separated by a dot.

Please, indicate this and other versions in the Versions menu to the technical support in order to simplify the problem solving.

VERSIONS	12:00
Exit...	
Control	2.02
Modulator HW	1.01
Modulator SW	1.00
5.0W _F 0.0W _F 35°C	

Modulator HW

This is the ATSC Modulator module hardware version. It is composed by two numbers separated by a dot.

Please, indicate this and other versions in the Versions menu to the technical support in order to simplify the problem solving.

VERSIONS	12:00
Exit...	
Control	2.02
Modulator HW	1.01
Modulator SW	1.00
5.0W _F 0.0W _F 35°C	

Modulator SW

This is the ATSC Modulator module software version. It is composed by two numbers separated by a dot.

Please, indicate this and other versions in the Versions menu to the technical support in order to simplify the problem solving.

3.5 LOG SCREEN



By clicking on the LOG icon, you enter the LOG screen. This isn't a real menu, like the others, but only a log view. The first event shown is the first event in the log. Move the knob to scroll the log up/down.

In the titlebar of the small centred window, the number of the event shown and the total number of events stored in the log are indicated. If the event is an alarm, a bell icon is drawn on the leftmost side of the titlebar. On the first row there are the date and time at which the event occurred. On the second line, a short description of the event is shown. On the left of the small window, a scrollbar is drawn, like in the menus of parameters. The scrollbar tab gives an idea of position in the list of the displayed event.

Click on the knob while viewing the log to go back to the Main Menu Icons.

3.6 ALARM SCREEN



By clicking on the ALM icon in the main menu, you enter the ACTIVE ALARMS screen. This isn't a real menu, like the others, but only a list of alarms that are currently active. When no alarm is present, "No alarms present." is written on the top of the list.

If at least an alarm is active, the first row of the list is selected. Move the knob to scroll the alarms list down/up.

On the left, a scrollbar is drawn, like in the menus of parameters. The scrollbar tab gives an idea position in the list of the selected alarm.

Click on the knob while viewing this screen to go back to the Main Menu Icons.

3.7 FIRMWARE UPGRADE

The control system firmware of the ATSC TRANSMITTER can be upgraded to later versions without removing the equipment from the rack or replacing any chip. You only need a Windows PC with a RS232 port and a serial cable.

Carefully follow the steps below to upgrade to a new firmware.

- Obtain EKAFlash software that must be installed on the PC. You can download EKAFlash from the manufacturer web site (www.elettronika.it). Install EKAFlash on the PC you want to use during the upgrade.
- Connect a straight (pin-to-pin) serial cable (D-SUB9 male on equipment side, D-SUB9 female on PC side) between the RS232 port of the equipment and a RS232 port of the PC.
- Launch EKAFlash, select the PC RS232 port used for the connection with the equipment, choose the firmware file (usually with .mfx extension) by pressing the "..." button and click on the Download button.
- Switch off the equipment and switch it on again.

The upgrade of the firmware should start. After upgrading, the equipment will automatically start with the new firmware.

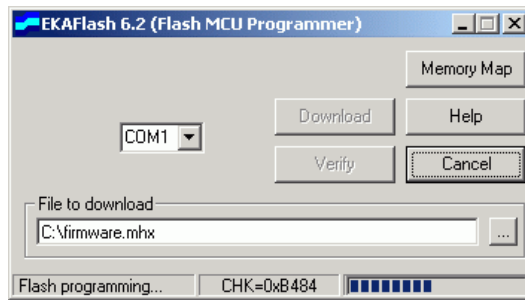

Warning! Keep in mind that the firmware upgrade is a critical task. You could have a non-working machine if the upgrading process doesn't end with success or if you download a wrong firmware.

ATSC Transmitter Menu Map

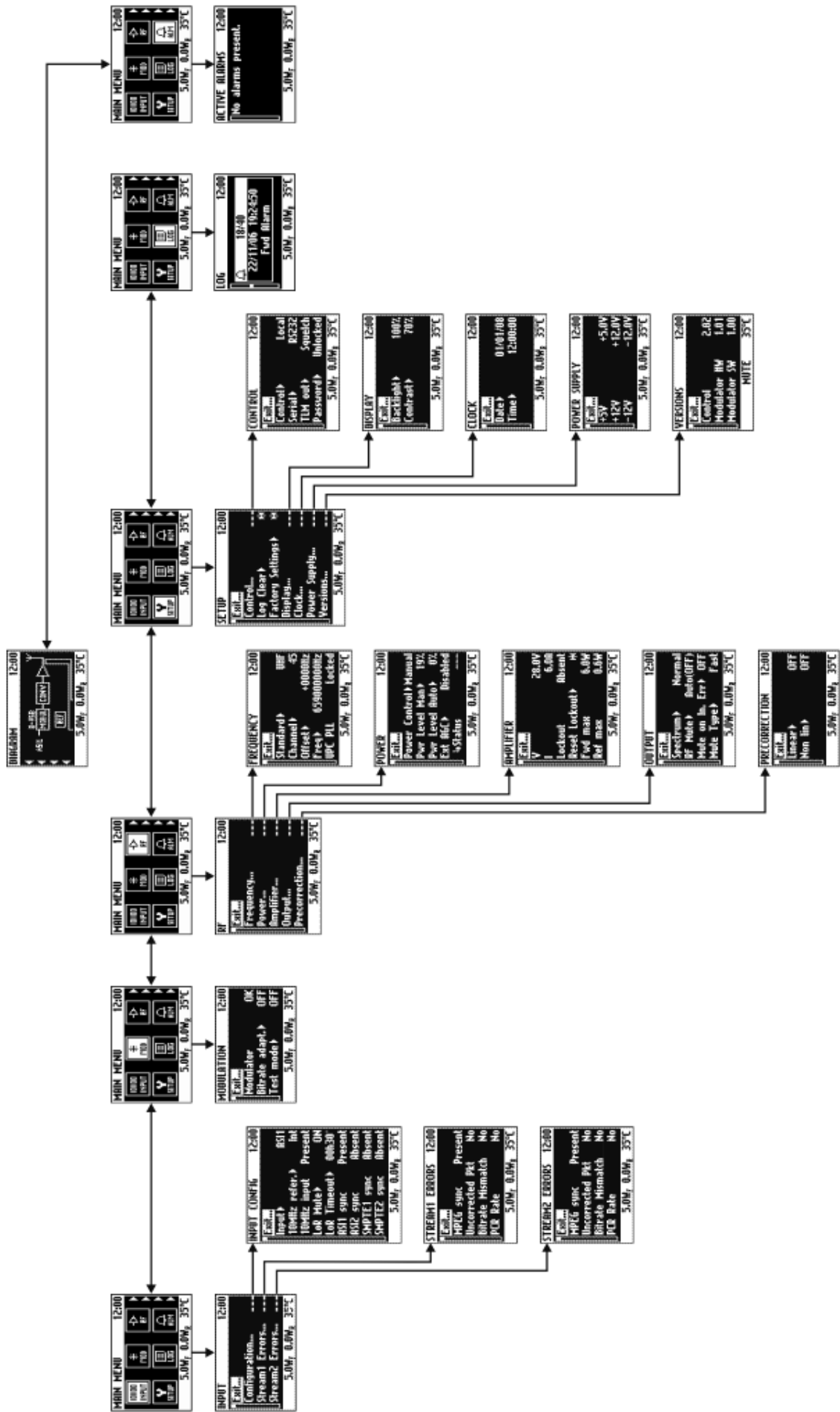

This page is intentionally blank

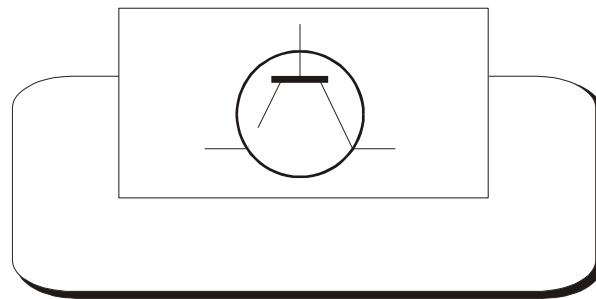



Section 4 - Diagram

Contents:

- APD043A UHF ATSC TRANSMITTER Cable Diagram*
- APD047A VHF-III ATSC TRANSMITTER Cable Diagram*
- APD045A VHF-I ATSC TRANSMITTER Cable Diagram*
- APD043A_APD047A_APD045A Component list*
- Modules description*

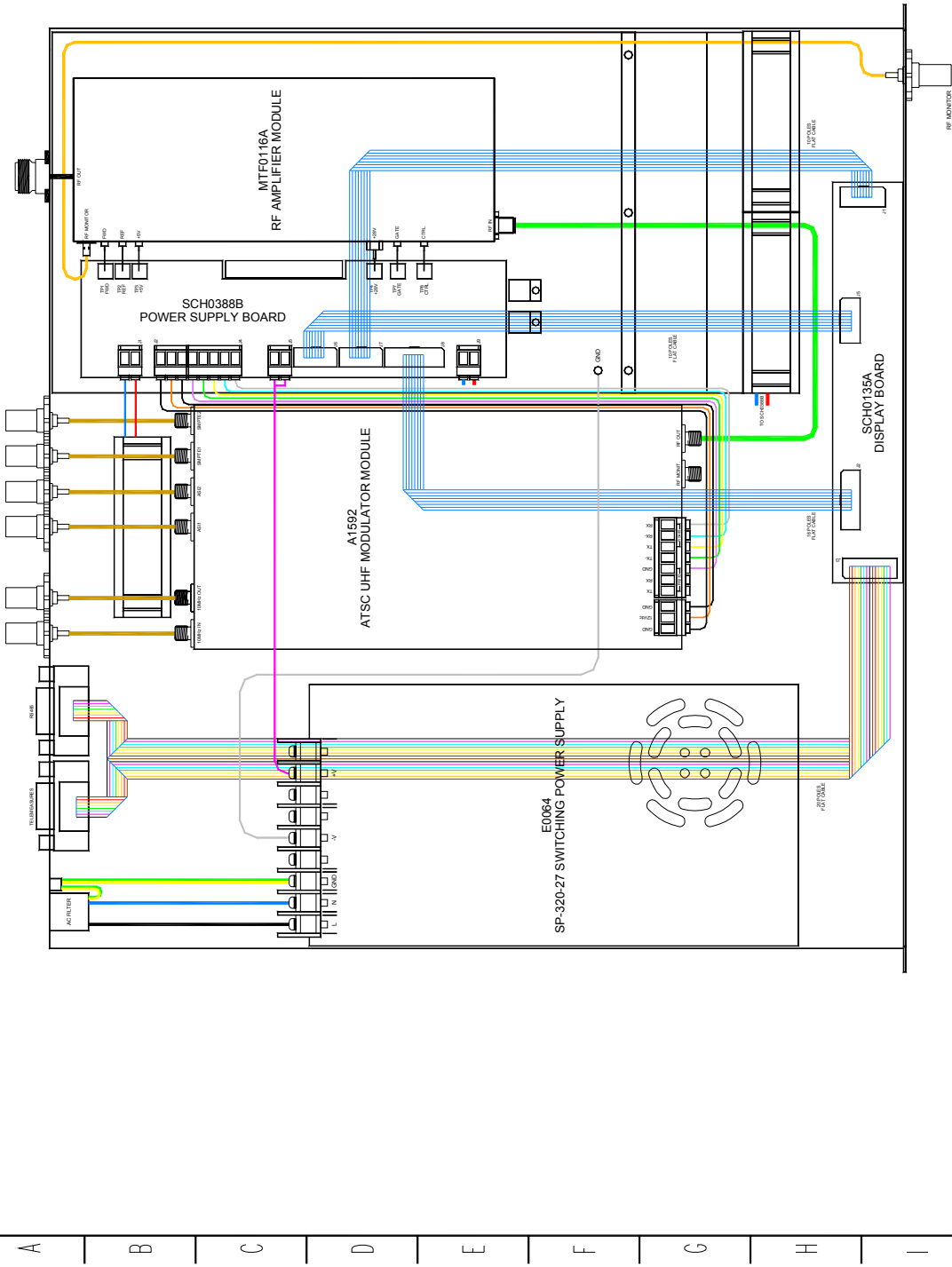
0 1 2 3 4 5 6 7 8 9



 ASSEMBLY CODE APD043A	TITLE UHF ATSC TRANSMITTER	DESIGNER LATTANZIO	SIGNATURE	DATE 12/03/08
		PCB DESIGNER LATTANZIO	SIGNATURE	PCB REF APD043A
				SHEET 1/1

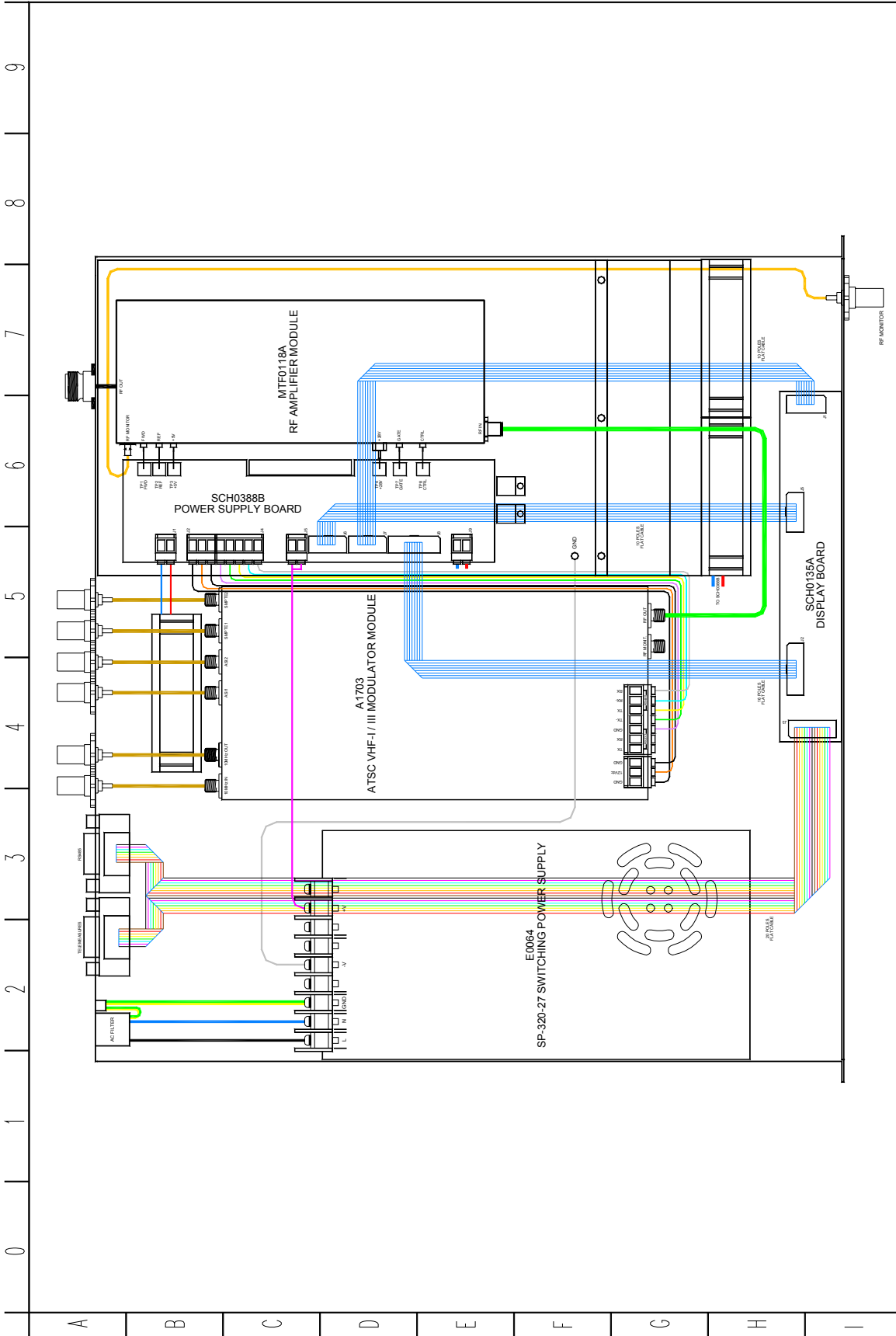

	CABLE DIAGRAM		DESIGNER	LATTANZIO	SIGNATURE	DATE	12/03/08
	ASSEMBLY CODE	APD047A	TITLE	VHF-III ATSC TRANSMITTER	PCB DESIGNER	LATTANZIO	PCB REF
						SHEET	1/1

Component list**APD043A - APD047A - APD045A**

Elettronika Code	Description	Qty
E0064	SP-320-27 DI SWITCHING POWER SUPPLY	1
MTF0116AR0	5W RMS UHF AMPLIFIER MODULE	1 (APD043A)
MTF0118AR0	5W RMS VHF-III AMPLIFIER MODULE	1 (APD047A)
MTF0125AR0	5W RMS VHF-I AMPLIFIER MODULE	1 (APD045A)
DET0531I	DET0531AR1 FAN CONVEYER	1
DET0600	DET0600R1 MECHANICAL DETAIL	1
07613	PAPST BLOWER	3
07602	BLOWER GRID	3
A1592	ATSC UHF MODULATOR MODULE	1
A1703	ATSC VHF-I/III MODULATOR MODULE	1 (APD047A_ APD045A)
PAN0187R0P	PAN0187R0 FRONT PANEL	1
02700	16 WAY FEMALE CONNECTOR	2
02701	16 WAY MALE CONNECTOR	1
02699	10 WAY MALE CONNECTOR	4
02867	20 WAY FEMALE CONNECTOR	1
02695	DB9 CONNECTOR FOR IU008059 CABLE	2
02518	SMB SOCKET FOR RG174 CABLE	1
02519	SMA SOCKET FOR RG174 CABLE	6
05069	TOROIDAL FILTER	1
DET0670	DET0670R0 MECHANICAL DETAIL	1
DET0315	DET0315R0 2U HANDLE KIT	2
08502	RG 316 50Ω CABLE	1.40
08521	RG 179 75Ω CABLE	0.60
SCH0135AR1	DISPLAY BOARD	1
02035	BNC FEMALE CONNECTOR FOR RG316 CABLE	8
DET1322R1P	DET1322R1P MECHANICAL DETAIL	1
DET1323R0P	DET1323R0P CONVEYER	1
DET0876I	DET0876R1 POWER SUPPLY CONVEYER	1
CON0352R2S	CON0352R2 BOX	1
CON0353R0P	CON0353R0P COVER	1
FLR0002	FUSE DRAWER	1
FLR0003	AC FILTER	1
FUS02A	2A FUSE	2
02503A	90° SMA SOCKET FOR RG 316 CABLE	2
V0760	BLACK PLASTIC TAP	2

This page is intentionally blank

DESCRIPTION

The Controller module, located on the right side of the DIGITAL TRANSMITTER, is the user interface of the whole modulator. It gathers the data from all the sections of the modulator, processes them by means of a 16bit flash micro-controller by Fujitsu and makes them available to the user both through the local interface, composed by a display and a knob, and the remote interface made up by the serial port (either the RS232 on the front or the RS485 on the back, as selected) or the interface of the telemeasuring connector.

The acquisition and setting of all the concerned parameters is made in two different ways. Analog measures reach the board from the individual modules as voltages, are conditioned on the board and then converted by an internal A/D converter in the micro.

The remaining parameters are gathered through a 2-wire RS485 interface, with the modulator. The display board acts as master on this 485 bus. Besides it is provided with an RTC and a non-volatile memory on an internal I2C bus.

- Dip-Switch

The display board is provided with 4 dip-switches. The dip-switches 3 and 4 are used to program the flash memory of the flash micro-controller by Fujitsu, in detail:

DIP3: On DIP4: Off	Boot Programming
DIP3: Off DIP4: On	Run or Firmware Programming

The "Boot Programming" configuration is only for BIOS programming purposes.

Once the BIOS has been programmed, the firmware has to be programmed at least once in order to use the board. The firmware programming and the normal operation of the board are obtained with the same position of the dip switches.

For more detail on Firmware upgrade please refer to the "Firmware Upgrade" section.

TECHNICAL CHARACTERISTICS

Flash ROM	256kByte
RAM	6kByte
EEPROM	64kBit
Serial interfaces	2xRS485 or 1xRS485 + 1xRS232
Graphic display	128x64pixel blue with white LED backlight
Encoder	Mechanical with push button
Clock and Calendar	Lithium battery backup
Telemeasures	Output: FWD, REF, Alarm/Mute Input: Remote ON/OFF

SCH0135AR1 Top layer Component layout

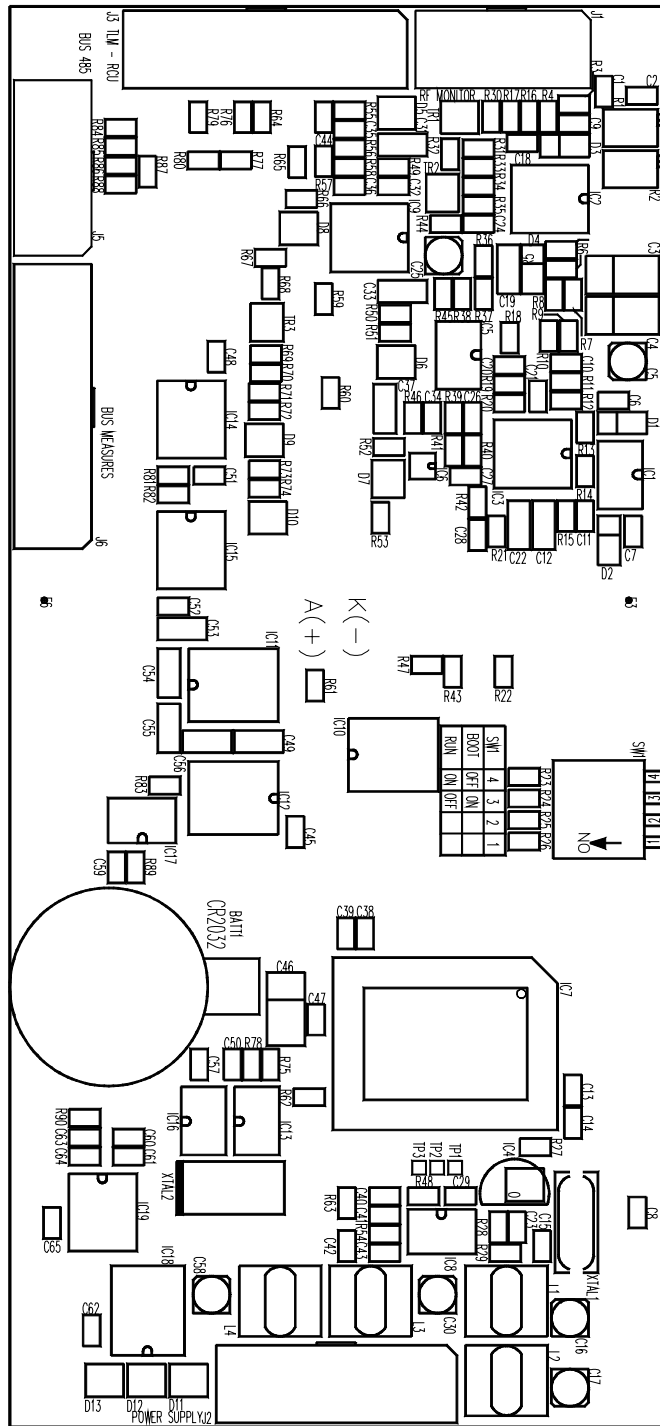

SCH0135AR1 Bottom layer Component layout

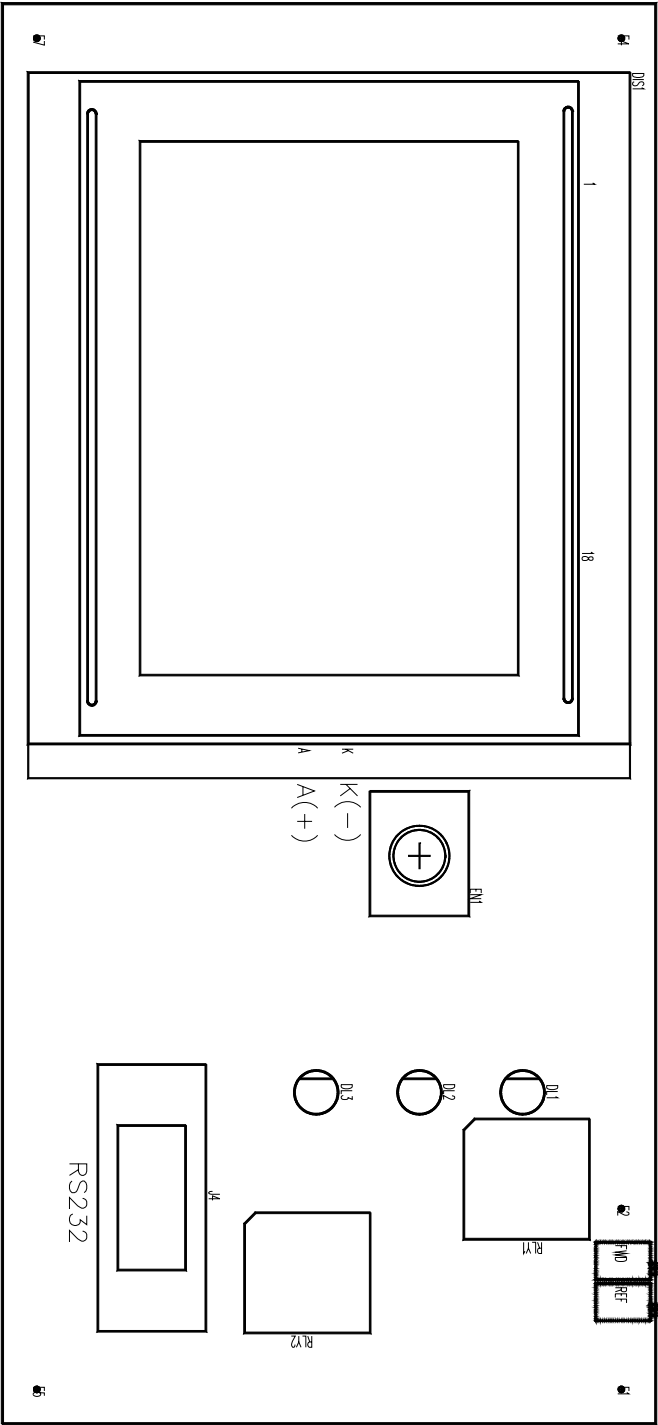

SCH0135ARI COMPONENT LIST

Part Name/Number	Description	Qty.	Comps.	Page 1/2
BATT BH001RB 3093_90	03093 03090 BATTERY HOLDER	1	BATT1	
CC 100nF-S 01065E	01065E Y5V 0805 COND	26	C7-8, C13, C18, C21, C23-24, C26, C29, C32, C34-36, C38-39, C43, C45, C47-48, C50-52, C57, C59, C62, C65	
CC 10nF-S 01053A	01053A SMD 0805 COND	1	C9	
CC 15pF-SS	01088A SMD 0805 COND	4	C10, C14-15, C20	
CC 1nF-S 01096A	01096A SMD 0805 COND	9	C1-2, C27-28, C44, C60-61, C63-64	
CC 1uF100V-S 01760A	01760A Y5V 1206 COND «50V»	9	C19, C31, C33, C37, C49, C53-56	
CC 220nF-S 01069B	01069B Y5V 0805 COND	3	C40-42	
CC 47pF-S 01090B	01090B SMD 0805 COND	2	C6, C11	
CE 10uF16V-S	01626B TANT. ELETTR SMD CO	2	C12, C22	
CE 10uF16V-S 01776A	01776A ELETTR SMD COND	4	C5, C17, C30, C58	
CE 22uF25V-S	01632 TANT. ELETTR SMD CON	1	C3	
CE 47uF 16V-S	01636A TANT. ELETTR SMD CO	1	C46	
CE 4u7F35V-S 01623A	01623A TANT. ELETTR SMD CO	1	C4	
CE 4u7F35V-S 01774A	01774A ELETTR SMD COND	1	C25	
CE D4 N. M.	N. M. ELETTR SMD COND	1	C16	
D BAS85-S	03024 SMD DIODE SCHOTTKY	3	D1-3	
D BAS85-S N. M.	N. M.	1	D4	
D BAT54S	03199 SMD SCH. DIODE A-K T	8	D5-6, D8-13	
D LM431-S	04614 SMD ADJ. ZENER	1	D7	
DIS MGLS12864T	03083A 128x64 DOT (BLUE-LED)	1	DIS1	
DL LEDG3 03053	03053 GREEN LED DIODE 3mm	1	DL1	
DL LEDR3 03058	03058 RED LED DIODE 3mm	1	DL3	
DL LEDY3 03051	03051 YEL. LED DIODE 3mm	1	DL2	
EN ENCODER DDM427	03095 ENCODER	1	EN1	
IC 24LC64 04815	04815 SMD INTEG CIRCUIT	1	IC13	
IC 74HC00-S 4762A	4762A SMD INTEG CIRCUIT	1	IC15	
IC AD5312BRM-S	04592A SMD INTEG CIRCUIT	1	IC6	
IC CD4053BC-S 04710A	04710A SMD INTEG CIRCUIT	2	IC12, IC18	
IC LM324M-S 04658A	04658A SMD INTEG CIRCUIT	1	IC2	
IC LM358M-S 04660	04660 SMD INTEG CIRCUIT	2	IC5, IC8	
IC LMC6484-S	04634 SMD INTEG CIRCUIT	3	IC3, IC9, IC19	
IC M41T56 04611	04611 SMD INTEG CIRCUIT	1	IC16	
IC MAX232-S 04804B	04804B SMD INTEG CIRCUIT	1	IC11	
IC MAX3080-S 04770	04770 SMD INTEG CIRCUIT	1	IC14	
IC MAX942CSA-S	04572 SMD INTEG CIRCUIT	1	IC1	
IC MB90F543PF	04596 SMD INTEG CIRCUIT	1	IC7	
IC MPC100T-450I-TT	04577 SMD INTEG CIRCUIT	1	IC4	
IC SN75176B-S 04720	04720 SMD INTEG CIRCUIT	1	IC17	
IC ULN2003A 4870	04870 SMD INTEG CIRCUIT	1	IC10	
IND MS85 10uH-S	04948 INDUCTOR 2,7A	3	L2-4	
IND MS85 N. M.	INDUCTOR N. M.	1	L1	

Part Name/Number	Description	Qty.	Comps.	Page 2/2
JDB9_F-0° LT	02794 PCB CON. DB9 LONG T	1	J4	
JFC-10P 02697-02699	02697+02699 PCB CON. POL	2	J1, J5	
JFC-16P 02701-02700	02701+02700 PCB CON. POL	1	J2	
JFC-20P 02868-02867	02868+02867 PCB CON. POL	2	J3, J6	
R 0805 N. M.	N. M. RES 1/4W 5% SMD 08	4	R6, R34, R65, R68	
R 0R0-SS	00001A RES 1/4W 5% SMD 0805	1	R35	
R 100K-S 00065C	00065C RES 1/4W 5% SMD 0805	7	R3-4, R8, R16, R36, R72, R74	
R 100R-S 00029B	00029B RES 1/4W 5% SMD 0805	6	R49-50, R60, R71, R73, R90	
R 10K-S 00053C	00053C RES 1/4W 5% SMD 0805	28	R11, R19, R22-27, R30-33, R38, R41, R43, R44-45, R47-48, R62, R67, R69-70, R81-83, R88-89	
R 10R-S 00017B	00017B RES 1/4W 5% SMD 0805	2	R7, R61	
R 150R-SS	00031C RES 1/4W 5% SMD 0805	2	R77, R85	
R 18K-S 00056A	00056A RES 1/4W 5% SMD 0805	1	R39	
R 1K0-S 00041C	00041C RES 1/4W 5% SMD 0805	12	R40, R42, R46, R52-53, R56-57, R64, R75, R78-79, R87	
R 1K5-SS	00043C RES 1/4W 5% SMD 0805	4	R76, R80, R84, R86	
R 1M-SS	00077B RES 1/4W 5% SMD 0805	1	R17	
R 22K-S 00057C	00057C RES 1/4W 5% SMD 0805	3	R12, R20, R28	
R 2K2-S 00045C	00045C RES 1/4W 5% SMD 0805	2	R13-14	
R 330R-S 00035C	00035C RES 1/4W 5% SMD 0805	2	R37, R66	
R 3K9-SS	00048C RES 1/4W SMD 0805	1	R58	
R 470K-SS	00073B RES 1/4W 5% SMD 0805	4	R5, R15, R21, R55	
R 470R-S 00037C	00037C RES 1/4W 5% SMD 0805	2	R9-10	
R 47K-S 00061C	00061C RES 1/4W 5% SMD 0805	2	R54, R63	
R 5K6-S 00050C	00050C RES 1/4W 5% SMD 0805	1	R29	
R 680R-SS	00039C RES 1/8W 1% SMD 0805	3	R18, R51, R59	
RL TQ2-SA-12 07569A	07569A RELE	2	RLY1-2	
RV 10K-3266X 00807	00807 VARIABLE RESISTOR	2	R1-2	
SW SWITCH-4DIP 90°	07531A PCB DIP SWITCH 90°	1	SW1	
TR BC848 03457	03457 NPN SMD TRANSISTOR	3	TR1-3	
XTAL 32.768k-S 05146	05146 QUARTZ	1	XTAL2	
XTAL 4MHz-S 05101A	05101A QUARTZ	1	XTAL1	

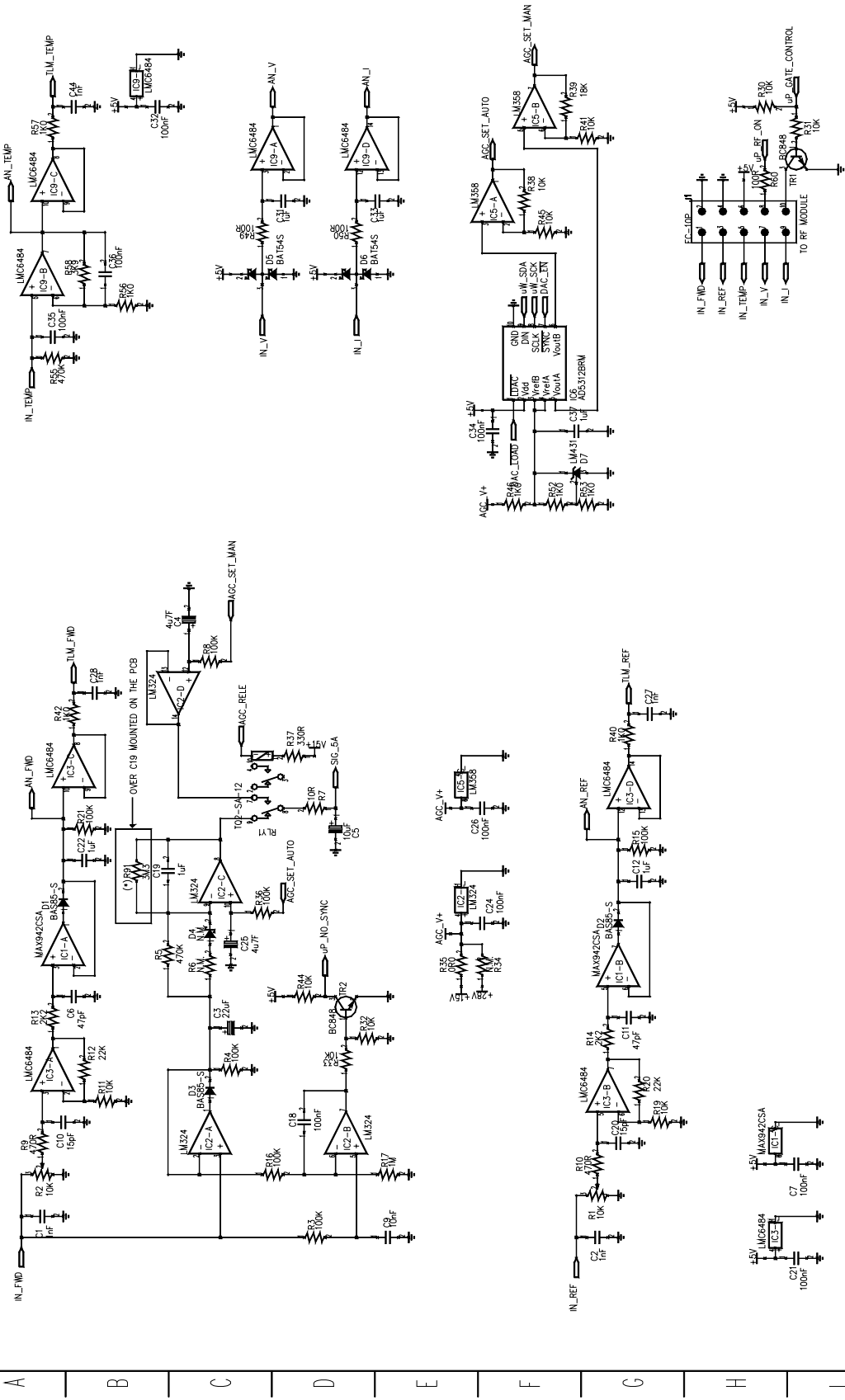

	TITLE SCH0135A	DESIGNER DE ROBERTIS	SIGNATURE TULLO	DATE 28/01/04
ASSEMBLY CODE SCH0135A	TITLE POWER LEVEL MEASURES SECTION	PCB DESIGNER TULLO	SIGNATURE	PCB REF PN091483
				SHEET 1/3

0 1 2 3 4 5 6 7 8 9

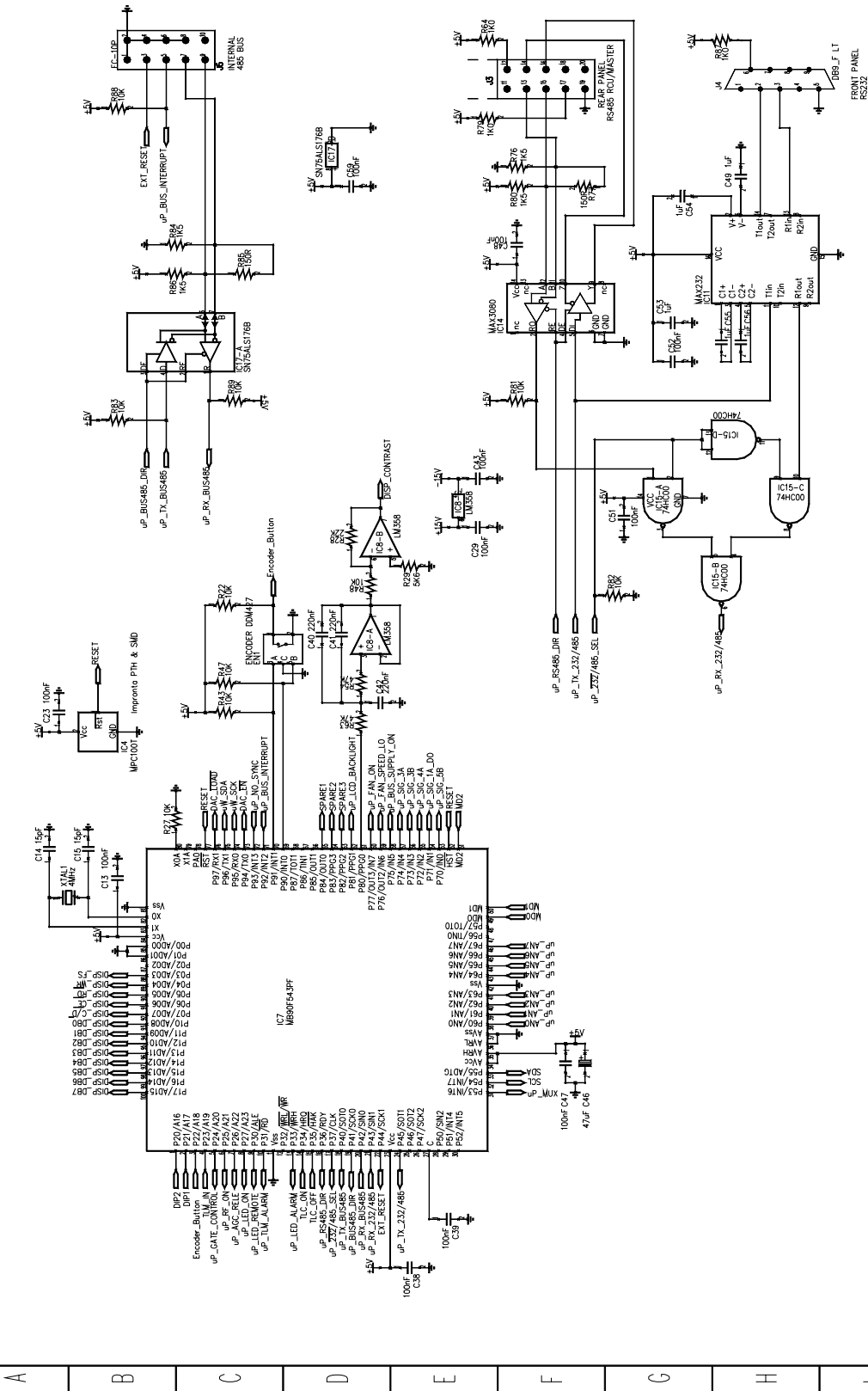

ASSEMBLY CODE	SCH0135A	TITLE	SERIAL AND MICROCONTROLLER SECTION	DESIGNER	DE ROBERTIS	SIGNATURE		DATE	28/01/04
				PCB DESIGNER	TULLO	SIGNATURE		PCB REF	PN091483
								SHEET	2/3

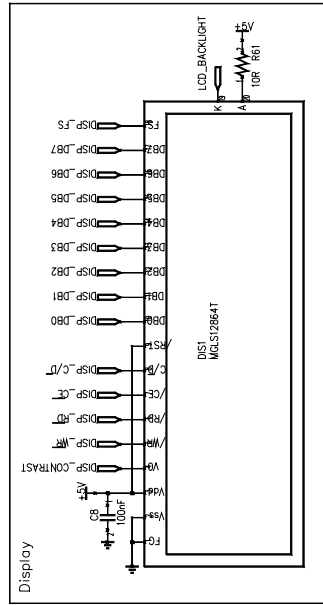
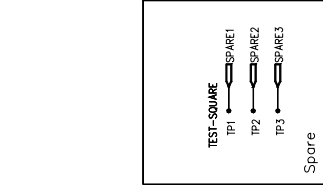
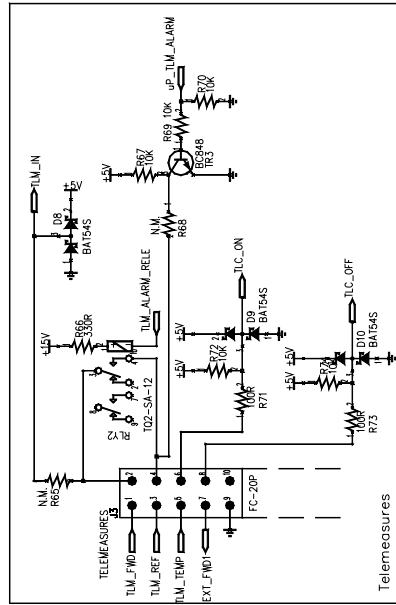
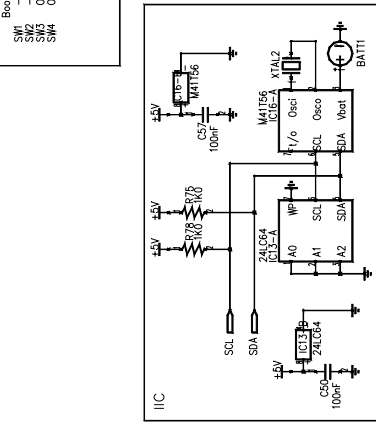
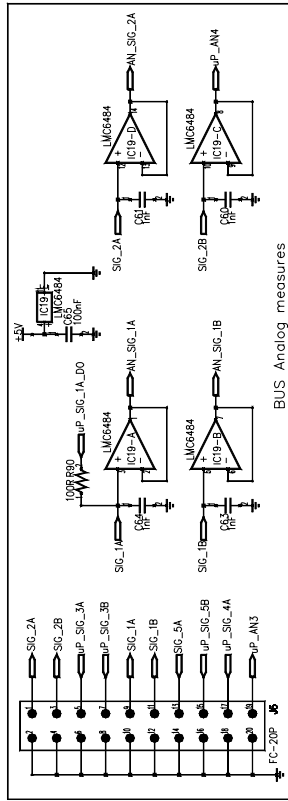
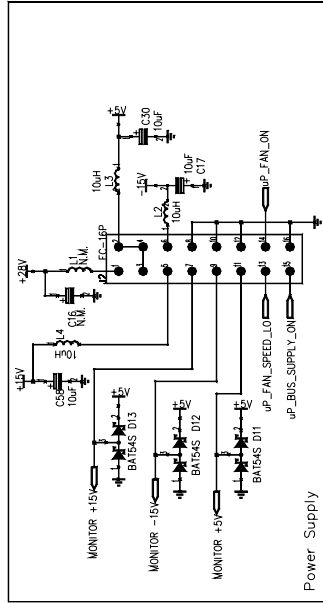
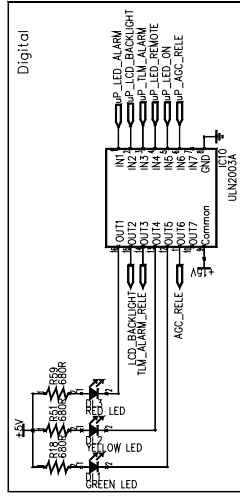
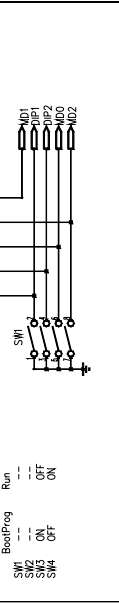
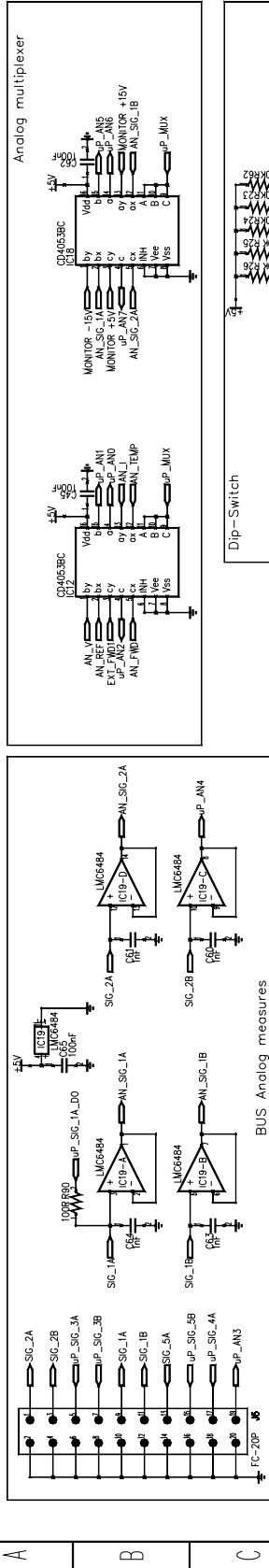

	ASSEMBLY CODE	SCH0135A	TITLE	PERIPHERALS SECTION	DESIGNER	DE ROBERTIS	SIGNATURE	DATE	28/01/04	
	PCB REF		PCB DESIGNER	TULLO			SIGNATURE	PCB REF	PN091483	
									SHEET	3/3

DESCRIPTION

The ATSC UHF Modulator module is a very high performance Digital TV modulator, fully compliant to the A/53 recommendation. The module includes highly linear 8-VSB modulation capability, excellent MER value, ASI and SMPTE-310M compatibility, digital pre-correction, low phase noise and high performance up converter.



MAIN FEATURES

- ATSC 8-VSB Modulator compliant with A/53 recommendation
- SMPTE-310M and ASI inputs
- Powerful TS input management (redundancy, automatic switching, bit rate adaptation, ...)
- Very high performance modulation (MER, RF stability, ...)
- Integrated digital pre-corrector (linear and non-linear)
- Low phase noise synthesizer for a high performance agile UHF output
- UHF Band IV & V output

CONNECTORS

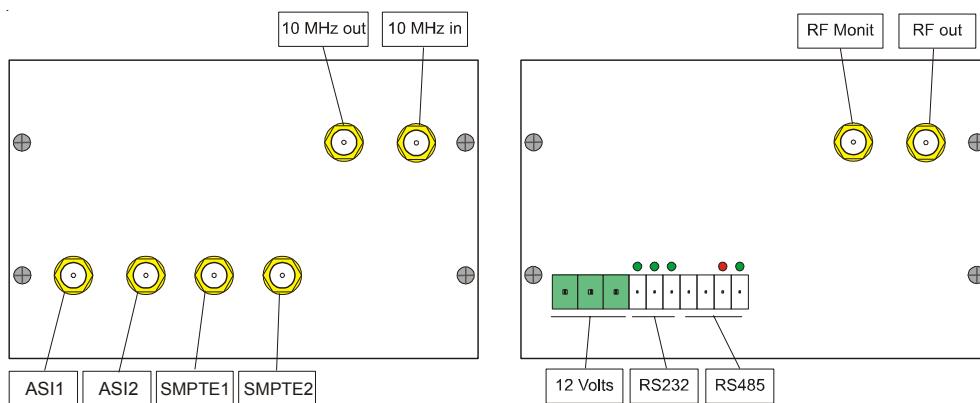

DESCRIPTION

The ATSC VHF Modulator module is a very high performance Digital TV modulator, fully compliant to the A/53 recommendation. The module includes highly linear 8-VSB modulation capability, excellent MER value, ASI and SMPTE-310M compatibility, digital pre-correction, low phase noise and high performance up converter.



MAIN FEATURES

- ATSC 8-VSB Modulator compliant with A/53 recommendation
- SMPTE-310M and ASI inputs
- Powerful TS input management (redundancy, automatic switching, bit rate adaptation, ...)
- Very high performance modulation (MER, RF stability, ...)
- Integrated digital pre-corrector (linear and non-linear)
- Low phase noise synthesizer for a high performance agile VHF output
- VHF Band I & III output

CONNECTORS

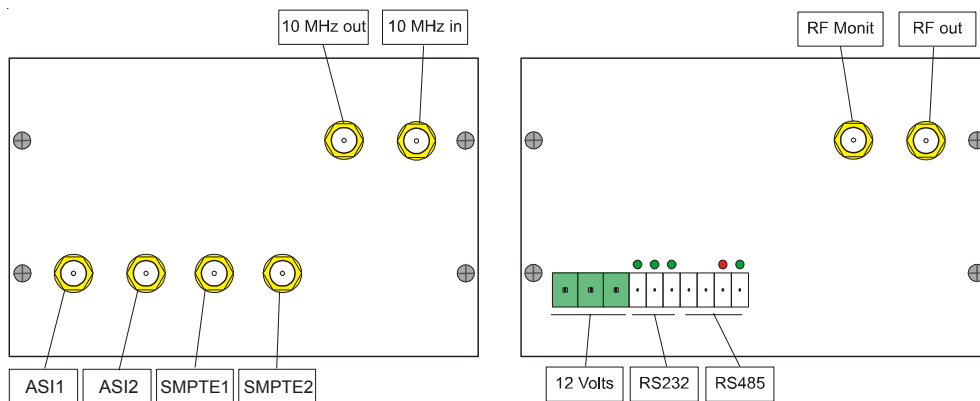

DESCRIPTION

The MTF0116A is the final stage of the 5W UHF RMS of the transmitter, based on LDMOS technology. It includes the final stage itself (SCH0417A), its cooling heatsink, and an interface board (SCH0388B) which allows to control the forward power, the reflect power, the Gain and the temperature. The final amplifier is provided with a GATE control to inhibit the power output, a circuit to monitor the output and the needed circuits to read the output forward and reflected power. The power reading is an RMS measurement.

TECHNICAL CHARACTERISTICS

Output Power	5W RMS
Frequency Range	470 - 860MHz
Gain	43dB±0.5
Power Supply	28V±2%
Total Quiescent Current (cold)	6A±5%
Output Impedance	50Ω
Input Impedance	50Ω
Input Return Loss	≥15dB

TRANSISTOR NAME	BIAS CURRENT
TR1 Pre-Driver BLF1043	0.4A
TR2 Driver BLF1043	0.6A
TR3 Output Stage MRF373	2.5A
TR4 Output Stage MRF373	2.5A

MTF0116A COMPONENT LIST

Part Name Code	Description	Qty
00432	50Ω 60W TERMINAL RESISTOR	1
00664	LM35DT THERMAL SENSOR	1
01400	BYPASSING CAPACITOR	2
01403	BYPASSING CAPACITOR	5
02209B	PANEL MOUNTING N SOCKET	1
02512	SMA SOCKET	1
02515	SMB SCREW cod. R114313000	1
03469	BLF1043.112 TRANSISTOR	2
04031A	MRF363ALR5 LDMOS TRANSISTOR	2
04340	LM317T VOLTAGE REGULATOR	1
07683	1.0mm SILVER WIRE	0.20
08502	RG316 50Ω CABLE	0.10
C0171	AWG22 TEFLON CABLE	0.25
DET1026	DET1026R0 MECHANICAL DETAIL	2
DET1320R1P	DET1320R1P MECHANICAL DETAIL	1
DET1330R2P	DET1330R2P HEAT SINK MODULE	1
SCA0115	SCA0115R0 COVER	1
SCA0128R1B	SCA0128R1B RF AMPLIFIER MODULE BOX	1
SCH0388BR1	POWER SUPPLY INTERFACE BOARD	1
SCH0417AR0	5W RMS UHF AMPLIFIER MODULE	1
V0771	3x5 MALE/FEMALE SPACER	4

MTF0116AR0 Component layout

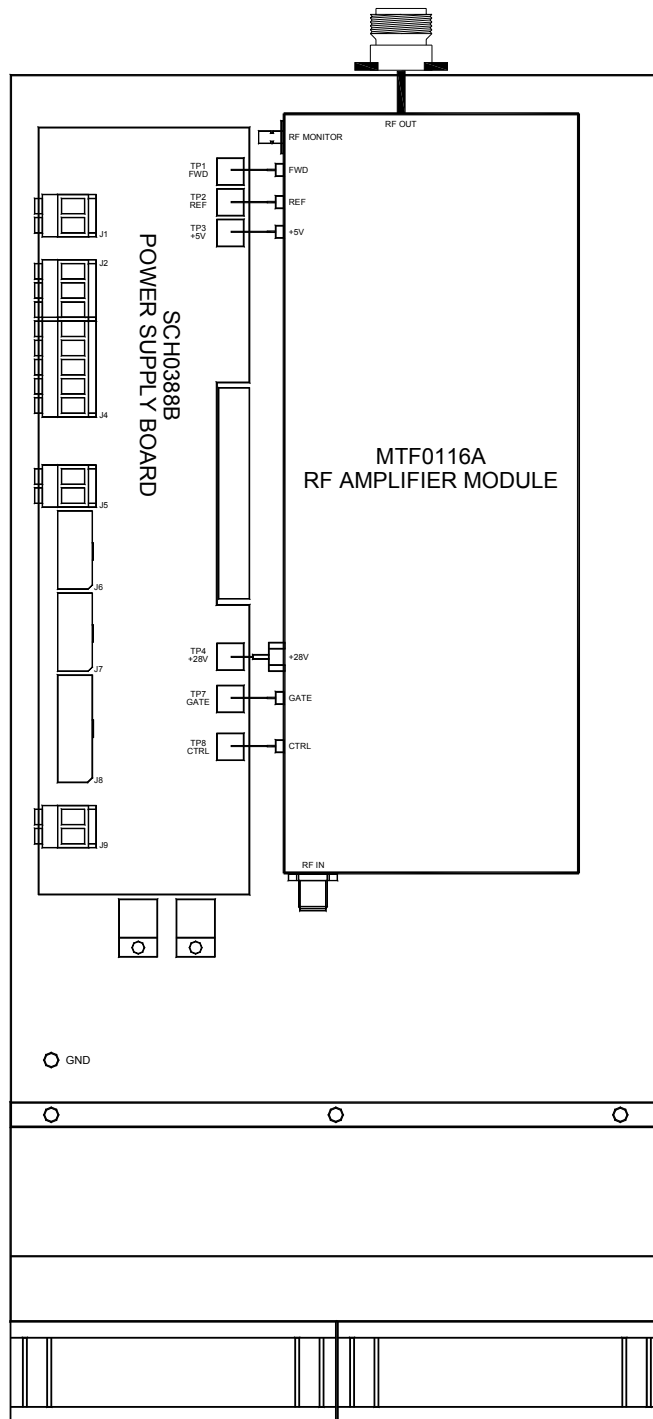

SCH0417AR0 Component layout

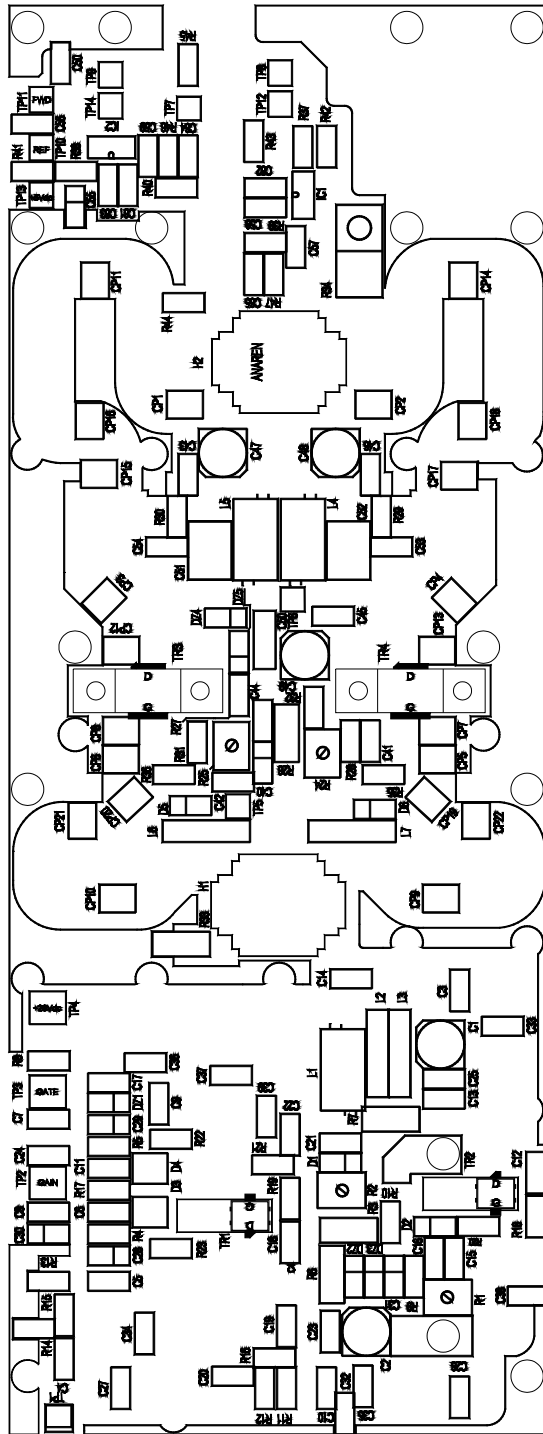

SCH0417AR0 COMPONENT LIST

Part Name/Number	Description	Qty.	Comps.
CC 100nF-S 01065C	01065C Y5V 1206 CAPACITOR	4	C43-46
CC 100pF-S 01092	01092 SMD 1206 CAPACITOR	2	C53-54
CC 1nF-S 01096	01096 SMD 1206 CAPACITOR	2	C41-42
CC 1uF 100V	01077A CERAMIC CAPACITOR	2	C51-52
CC 470nF 63V-S	01073 POLIESTER SMD CAPAC.	1	C50
CE 10uF16V-S	01626B TANT. ELET. CAPACITOR	1	C40
CE 10uF50V-S 01779A	01779A ELET. SMD CAPACITOR	3	C47-49
CP 10pF-S	CHIP CHB	2	CP7-8
CP 12pF-S	CHIP CHB	2	CP5-6
CP 15pF-S	01121 CHIP CHB	4	CP1-4
CP 1p8F-S	01102A CHIP CHB	4	CP11-14
CP 47pF-S	01130 CHIP CHB	2	CP9-10
CP 5p6F-S	01109 CHIP CHB	2	CP21-22
CP 6p8F-S	CHIP CHB	6	CP15-20
D 1N4148-S 03002	03002 SMD DIODE	2	D5-6
DZ 3V9-S	03134 SMD ZENER DIODE	2	DZ4-5
HANAREN 1F1304-3	05368 HIBRID COUPL. ANAREM	2	H1-2
IND CBD8 05072	05072 INDUCTOR	2	L6-7
IND VK200 05013	05013 INDUCTOR	2	L4-5
R 10R-S 00017A	00017A RES 1/4W 5% SMD 1206	2	R29-30
R 1K5-S 00043A	00043A RES 1/4W 5% SMD 1206	2	R35-36
R 22K-S 00057A	00057A RES 1/4W 5% SMD 1206	2	R31-32
R 3K3-1W-S	00400 RES 1W 5% SMD 2512	1	R26
R 47K-S 00061A	00061A RES 1/4W 5% SMD 1206	2	R27-28
R 47R-1W-S	00384 RES 1W 5% SMD 2512	1	R33
R 50R 60W TERM	00432 50Ω 60W RF TERM	1	R34
RV 50K-S-H/S 00797	00797 SMD VARIABLE RESISTOR	2	R24-25
TR MRF373A-S	04031A LDMOS TRANSISTOR	2	TR3-4

0 1 2 3 4 5 6 7 8 9

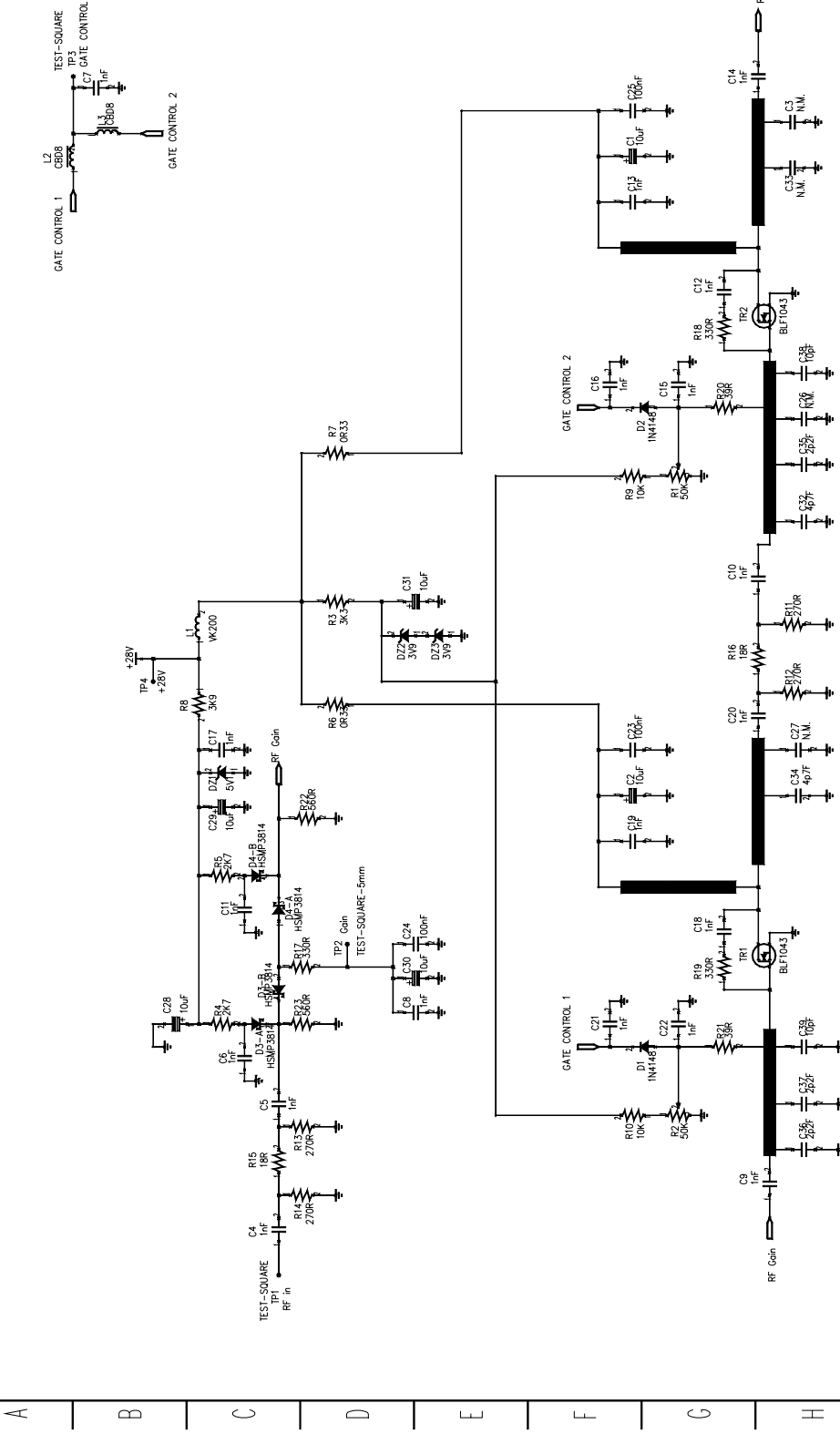

ELSATRONIKA S.r.l.	ELECTRIC DIAGRAM		DESIGNER	LAVOUIPE	SIGNATURE	DATE	28/11/06
	ASSEMBLY CODE	SCH0417A	PCB DESIGNER	TULLO	SIGNATURE	PCB REF	PN1300ART
TITLE		5W UHF RMS AMPLIFIER MODULE DRIVER SECTION		SHEET		1/1	

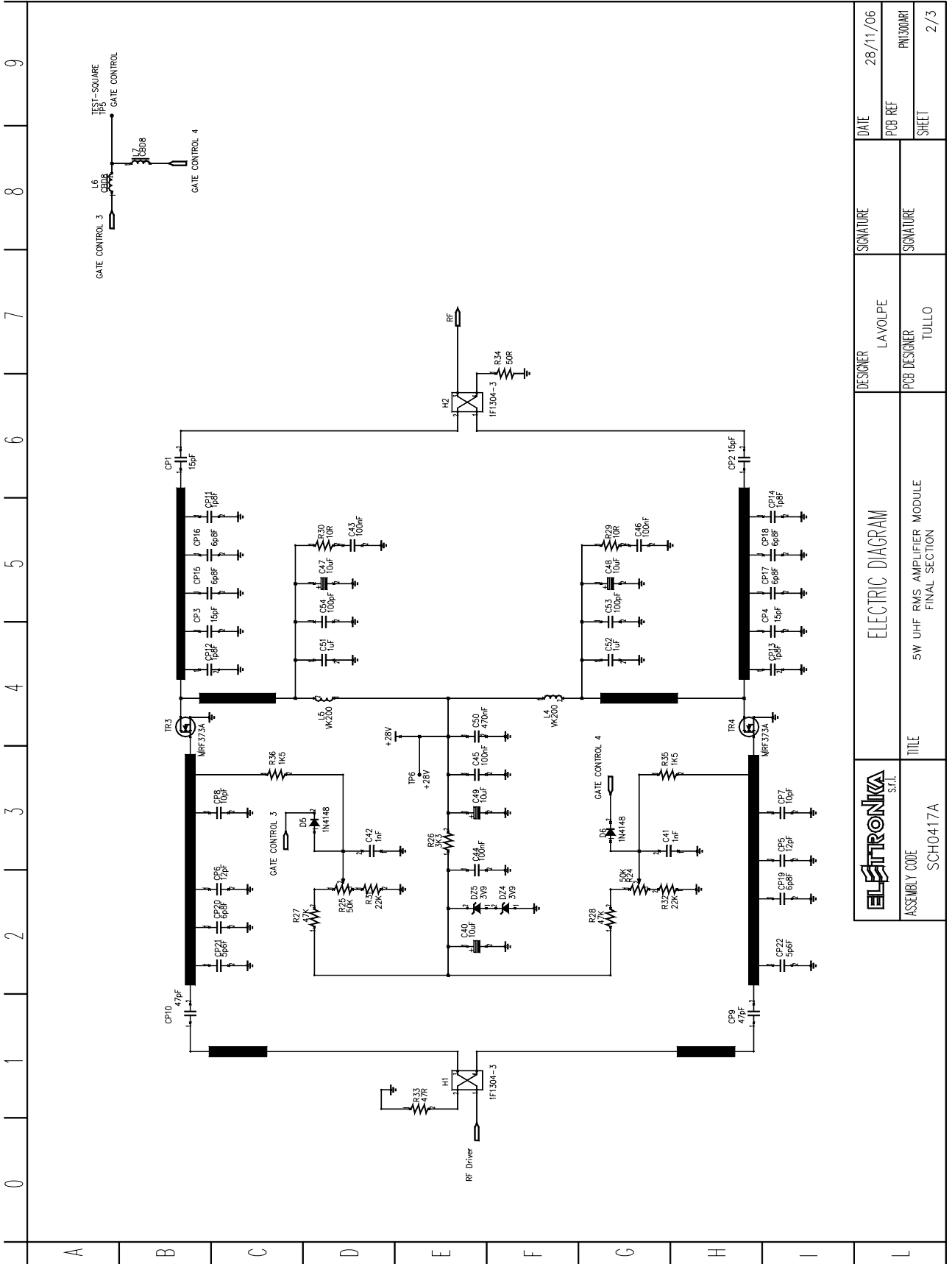

		TITLE 5W UHF RMS AMPLIFIER MODULE FINAL SECTION SCH0417A		DESIGNER LAVOLPE		SIGNATURE		DATE 28/11/06	
				PCB DESIGNER TULLO		SIGNATURE		PCB REF PN1300ARI	

0 1 2 3 4 5 6 7 8 9

A B C D E F G H I L

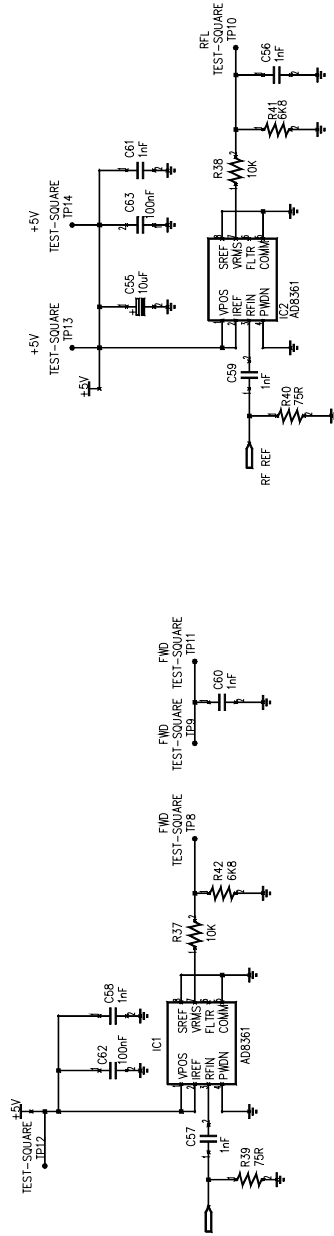
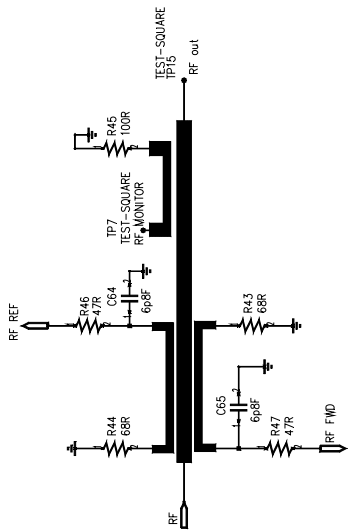

ELSTRONIKA
s.r.l.

ELECTRIC DIAGRAM

DESIGNER: LAVOLPE
PCB DESIGNER: TULLO

DATE: 28/11/06
PCB REF: PW300ARI
SHEET: 3/3

ASSEMBLY CODE: SCH0417A
TITLE: 5W UHF RMS AMPLIFIER MODULE MEASURE SECTION

DESCRIPTION

The MTF0118A is the final stage of the 5W VHF RMS of the transmitter, based on MOS technology. It includes the final stage itself (SCH0436A), its cooling heatsink, and an interface board (SCH0388B) which allows to control the forward power, the reflect power, the Gain and the temperature. The final amplifier is provided with a GATE control to inhibit the power output, a circuit to monitor the output and the needed circuits to read the output forward and reflected power. The power reading is an RMS measurement.

TECHNICAL CHARACTERISTICS

Output Power	5W RMS
Frequency Range	170 - 230MHz
Gain	43dB±0.5
Power Supply	28V±2%
Total Quiescent Current (cold)	2.6A
Output Impedance	50Ω
Input Impedance	50Ω
Input Return Loss	≥15dB

TRANSISTOR NAME	BIAS CURRENT
TR1 Pre-Driver BLF1043	0.4A
TR2 Driver BLF1043	0.6A
TR3 Output Stage MRF373	1.5A

MTF0118A COMPONENT LIST

Part Name Code	Description	Qty
00432	50Ω 60W TERMINAL RESISTOR	1
00664	LM35DT THERMAL SENSOR	1
01400	BYPASSING CAPACITOR	2
01403	BYPASSING CAPACITOR	5
02209B	PANEL MOUNTING N SOCKET	1
02512	SMA SOCKET	1
02515	SMB SCREW cod. R114313000	1
03469	BLF1043.112 TRANSISTOR	2
04031A	MRF363ALR5 LDMOS TRANSISTOR	1
04340	LM317T VOLTAGE REGULATOR	1
07683	1.0mm SILVER WIRE	0.20
08502	RG 316 50Ω CABLE	0.10
C0171	AWG22 TEFLON CABLE	0.25
DET1026	DET1026R0 MECHANICAL DETAIL	2
DET1320R1P	DET1320R1P MECHANICAL DETAIL	1
DET1330R2P	DET1330R2P HEAT SINK MODULE	1
SCA0115	SCA0115R0 COVER	1
SCA0128R1B	SCA0128R1B RF AMPLIFIER MODULE BOX	1
SCH0388BR1	POWER SUPPLY INTERFACE BOARD	1
SCH0436AR0	5W RMS VHF AMPLIFIER MODULE	1
V0771	3x5 MALE/FEMALE SPACER	4

MTF0118A Component layout

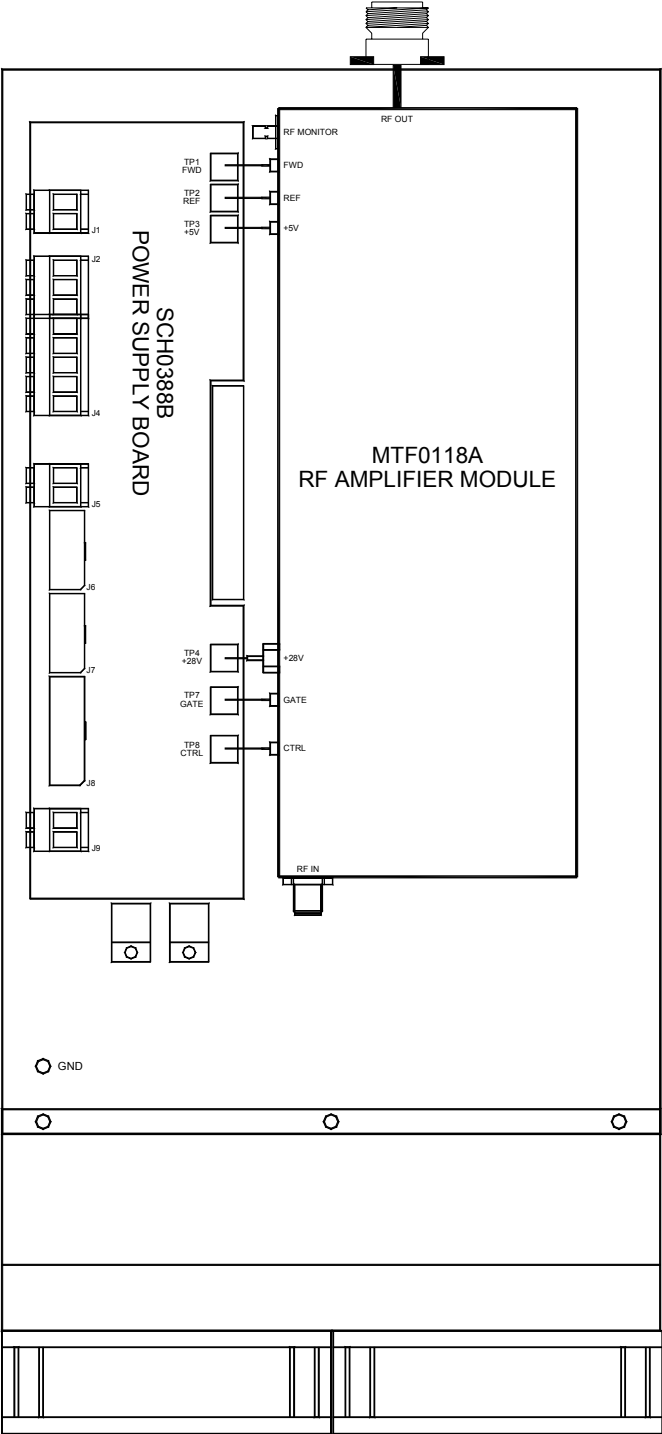

SCH0436AR0 Component layout

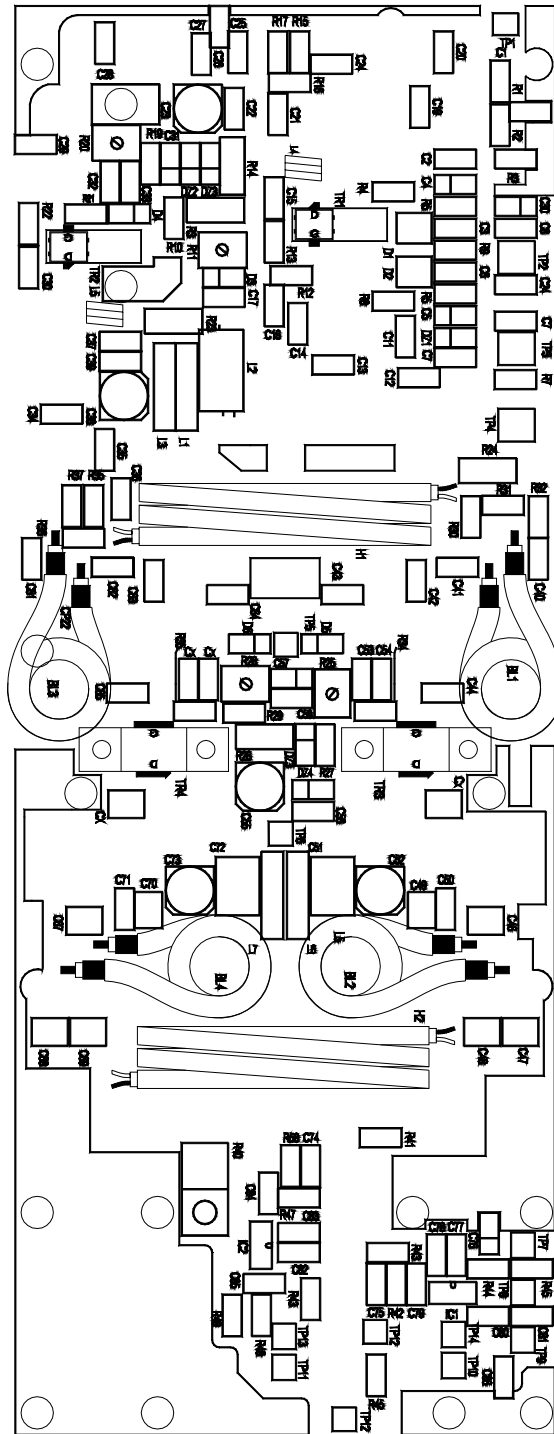

SCH0436AR0 COMPONENT LIST

Part Name/Number	Description	Qty.	Comps.	Page 1/2
CC 100nF-S 01065C	01065C Y5V 1206 CAPACITOR	11	C9, C17, C23, C33, C39, C56, C58, C77, C80, C82, C85	
CC 100pF-S 01092	01092 SMD 1206 CAPACITOR	2	C50, C54	
CC 10pF-S 01086	01086 SMD 1206 CAPACITOR	2	C14, C29	
CC 1206 N. M.	N. M. SMD 1206 CAPACITOR	4	C20, C28, C34-35	
CC 1nF 01041	01041 CERAMIC CAPACITOR	1	C45	
CC 1nF-S 01096	01096 SMD 1206 CAPACITOR	26	C1-3, C6-7, C10-11, C15-16, C18, C21, C24, C25, C30, C32, C36-37, C41, C49, C53, C78, C79, C81, C83-84, C86	
CC 1uF 100V	01077A CERAMIC CAPACITOR	1	C51	
CC 2p2F-S 01081B	01081B SMD 1206 CAPACITOR	3	C12-13, C27	
CC 33pF-S 1023A	1023A SMD 1206 CAPACITOR	1	C44	
CC 47pF-S 01100	01100 SMD 1206 CAPACITOR	2	C40, C43	
CC 4p7F-S 01083	01083 SMD 1206 CAPACITOR	2	C19, C26	
CC 68pF-S 01027A	01027A SMD 1206 CAPACITOR	1	C42	
CC 6p8F-S 01084	01084 SMD 1206 CAPACITOR	2	C74-75	
CE 10uF16V-S	01626B TANT. ELET. SMD CAP.	6	C4-5, C8, C31, C57, C76	
CE 10uF50V-S 01779A	01779A ELET. SMD CAPACITOR	4	C22, C38, C52, C55	
CP 10pF-S	01117 CHIP CHB	1	C47	
CP 1nF-S	01145 CHIP CHB	1	C48	
CP 33pF-S	01127 CHIP CHB	1	C46	
D 1N4148-S 03002	03002 SMD DIODE	3	D3-5	
D HSMP3814	03202 SMD DIODE	2	D1-2	
DZ 3V9-S	03134 SMD ZENER DIODE	4	DZ2-5	
DZ 5V1-S 03128	03128 SMD ZENER DIODE	1	DZ1	
ICAD8361 04899	04899 SMD INTEG CIRCUIT	2	IC1-2	
IND 0u6H	INDUCTOR	2	L4-5	
IND CBD8 05072	05072 INDUCTOR	3	L1, L3, L6	
IND VK200 05013	05013 INDUCTOR	1	L2	
R 0R33-1W-S	00380 RES 1W 5% SMD 2512	2	R14, R23	
R 100R-1/2W 00139	00139 RES 1/2W 5%	1	R33	
R 100R-S 00029A	00029A RES 1/4W 5% SMD 1206	3	R44, R46, R48	
R 10K-1%-S 00053B	00053B RES 1/4W 1% SMD 1206	2	R10, R19	
R 10R-S 00017A	00017A RES 1/4W 5% SMD 1206	1	R34	
R 1206 N. M.	N. M. RES 1/4W 5% SMD 1206	2	R45, R49	
R 18R-S 00020A	00020A RES 1/4W 5% SMD 1206	3	R2, R16, R31	
R 270R-S 00034A	00034A RES 1/4W 5% SMD 1206	6	R1, R3, R15, R17, R30, R32	
R 2K7-1%-S	00046B RES 1/4W 1% SMD 1206	2	R5-6	
R 330R-S 00035B	00035B RES 1/4W 5% SMD 1206	3	R9, R13, R22	
R 39R-S 00024A	00024A RES 1/4W 5% SMD 1206	2	R12, R21	
R 3K3-1W-S	00400 RES 1W 5% SMD 2512	2	R18, R26	
R 3K9-1%-S 00048B	00048B RES 1/4W 1% SMD 1206	1	R7	
R 47R-S 00025A	00025A RES 1/4W 5% SMD 1206	2	R42, R58	

Part Name/Number	Description	Qty.	Comps.	Page 2/2
R 560R-1%-S 00038B	00038B RES 1/4W 1% SMD 1206	2	R4, R8	
R 56K-S	00062A RES 1/4W 5% SMD 1206	1	R27	
R 68R-S 00027A	00027A RES 1/4W 5% SMD 1206	2	R41, R54	
R 75R-1%-S 00221B	00221B RES 1/4W 1% SMD 1206	2	R43, R47	
RV 50K-S-H/S 00797	00797 SMD VARIABLE RESISTOR	3	R11, R20, R25	
TR BLF1043-S	03469 LDMOS TRANSISTOR	2	TR1-2	
TR MRF373A-S	04031A LDMOS TRANSISTOR	1	TR3	

0 1 2 3 4 5 6 7 8 9

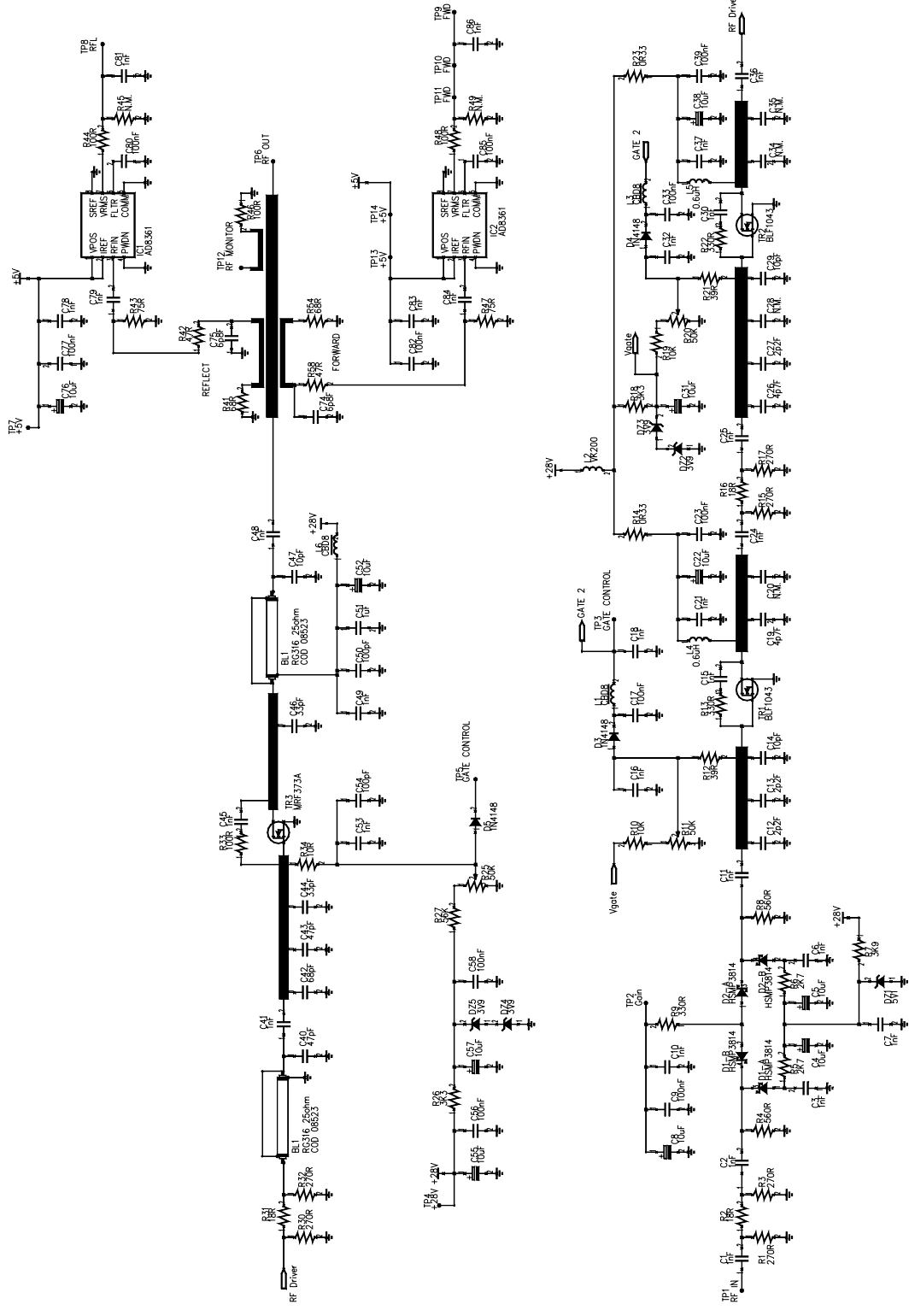

	ELECTRIC DIAGRAM		DESIGNER	DI MODUGNO	SIGNATURE	DATE	28/03/07
	TITLE		PCB DESIGNER	DI MODUGNO	SIGNATURE	PCB REF	PN1324ART
ASSEMBLY CODE		SCH04.36A		5W VHF RMS AMPLIFIER MODULE		SHEET	1/1

DESCRIPTION

The MTF0125A is the final stage of the 5W VHF-I RMS of the transmitter, based on MOS technology. It includes the final stage itself (SCH0320A), its cooling heatsink, and an interface board (SCH0388B) which allows to control the forward power, the reflect power, the Gain and the temperature. The final amplifier is provided with a GATE control to inhibit the power output, a circuit to monitor the output and the needed circuits to read the output forward and reflected power. The power reading is an RMS measurement.

TECHNICAL CHARACTERISTICS

Output Power	5W RMS
Frequency Range	55 - 90MHz
Gain	32 - 34dB ±0.5
Power Supply	28V ±2%
Total Quiescent Current (cold)	2.6A
Output Impedance	50Ω
Input Impedance	50Ω
Input Return Loss	≥15dB

TRANSISTOR NAME	BIAS CURRENT
TR1 Pre-Driver BLF1043	0.4A
TR2 Driver BLF1043	0.6A
TR3 Output Stage MRF373	1.5A

MTF0125A COMPONENT LIST

Part Name Code	Description	Qty
00041B	1kΩ 1206 SMD RESISTOR	1
00664	LM35DT THERMAL SENSOR	1
01041	1nF 50V CERAMIC CAPACITOR	1
01096	1nF MULTITURN CHIP CAPACITOR	1
01400	BYPASSING CAPACITOR	2
01403	BYPASSING CAPACITOR	5
02238	N FLANGE FEMALE CONNECTOR	1
02502	SMA SOCKET	1
02515	SMB SCREW	1
03202	HSMP 3814-TRIG DIODE	1
03469	BLF 1043 TRANSISTOR	1
03985	BLF 245 TRANSISTOR	1
05013	VK200	1
08502	RG 316 50Ω CABLE	0.10
DET1026	DET1026R0 MECHANICAL DETAIL	1
DET1492R0P	DET1492R0 HEAT SINK MODULE	1
SCA0091	SCA0091R0 COVER	1
SCA0140R0B	SCA0140R0 AMPLIFIER MODULE BOX	1
SCH0320AR0	VHF AMPLIFIER MODULE	1
SCH0388BR1	POWER SUPPLY INTERFACE BOARD	1
V0771	3x5 MALE/FEMALE SPACER	4

MTF0125A Component layout

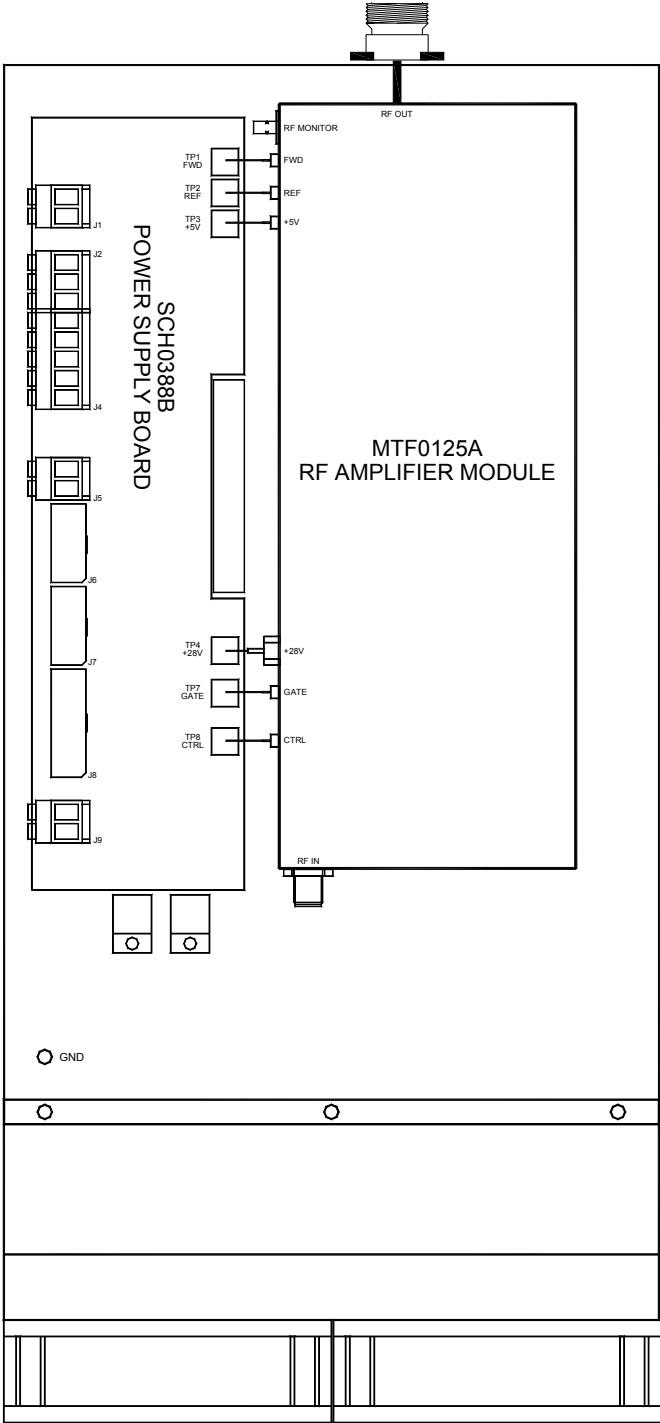

SCH0320AR0 VHF-I Amplifier Board Component layout

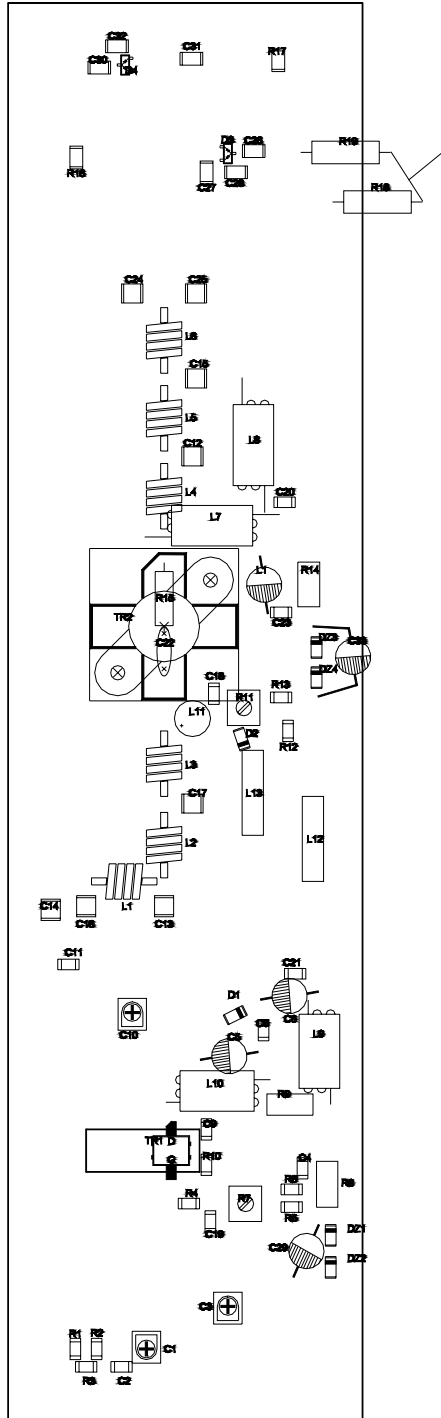

SCH0320AR0 COMPONENT LIST

Part Name/Number	Description	Qty.	Comps.
CC 100nF-S 01065C	01065C Y5V 1206 CAPACITOR	3	C4, C21, C23
CC 10nF 01053	01053 CERAMIC CAPACITOR	1	C22
CC 1206 N. M.	N. M. SMD 1206 CAPACITOR	2	C28, C32
CC 1nF-S 01096	01096 SMD 1206 CAPACITOR	10	C2, C8-9, C18-20, C26-27, C30-31
CC 4p7F1%-S 01083A	01083A SMD 1206 CAPACITOR	1	C11
CE 10uF63V 01779	01779 ELET. CAPACITOR	5	C5-7, C29, C33
CP 100pF-S	01135 CHIP CHB	1	C12
CP 180pF-S	01137A CHIP CHB	1	C17
CP 1nF-S	01145 CHIP CHB	2	C14, C25
CP 22pF-S	01125 CHIP CHB	1	C24
CP 51pF-S	01129 CHIP CHB	1	C16
CP 68pF-S	01131 CHIP CHB	2	C13, C15
CV 3-10pF-S 01475	01475 VARIABLE CAPACITOR	3	C1, C3, C10
D 1N4148-S 03002	03002 SMD DIODE	2	D1-2
D BAT54S	03199 SMD SCHOTTKY DIODE	2	D3-4
DZ 3V9-S	03134 SMD ZENER DIODE	4	DZ1-4
IND CBD8 05072	05072 INDUCTOR	2	L12-13
IND RFC-G	INDUCTOR	6	L1-6
IND VK200 05013	05013 INDUCTOR	5	L7-11
R 0R68-1W-S	00381 RES 1W 5% SMD 2512	1	R9
R 100R-S 00029A	00029A RES 1/4W 5% SMD 1206	2	R16-17
R 10K 0053	0053 RES 1/4W 5%	1	R19
R 18R-S 00020A	00020A RES 1/4W 5% SMD 1206	1	R3
R 22K-S 00057A	00057A RES 1/4W 5% SMD 1206	2	R6, R12
R 270R-1/2W	00144 RES 1/2W 5%	1	R15
R 270R-S 00034A	00034A RES 1/4W 5% SMD 1206	2	R1-2
R 330R-S 00035B	00035B RES 1/4W 5% SMD 1206	1	R10
R 33K-S 00059A	00059A RES 1/4W 5% SMD 1206	1	R13
R 39R-S 00024A	00024A RES 1/4W 5% SMD 1206	1	R4
R 47K-S 00061A	00061A RES 1/4W 5% SMD 1206	1	R5
R 4K7-1W-S	00401 RES 1W 5% SMD 2512	2	R8, R14
R 56R 0026	0026 RES 1/4W 5%	1	R18
RV 50K-S-H/S 00797	00797 SMD VARIABLE RESISTOR	2	R7, R11
TR BLF1043-S	03469 LDMOS TRANSISTOR	1	TR1
TR BLF245-S	03985 LDMOS TRANSISTOR	1	TR2

0 1 2 3 4 5 6 7 8 9

A B C D E F G H I L

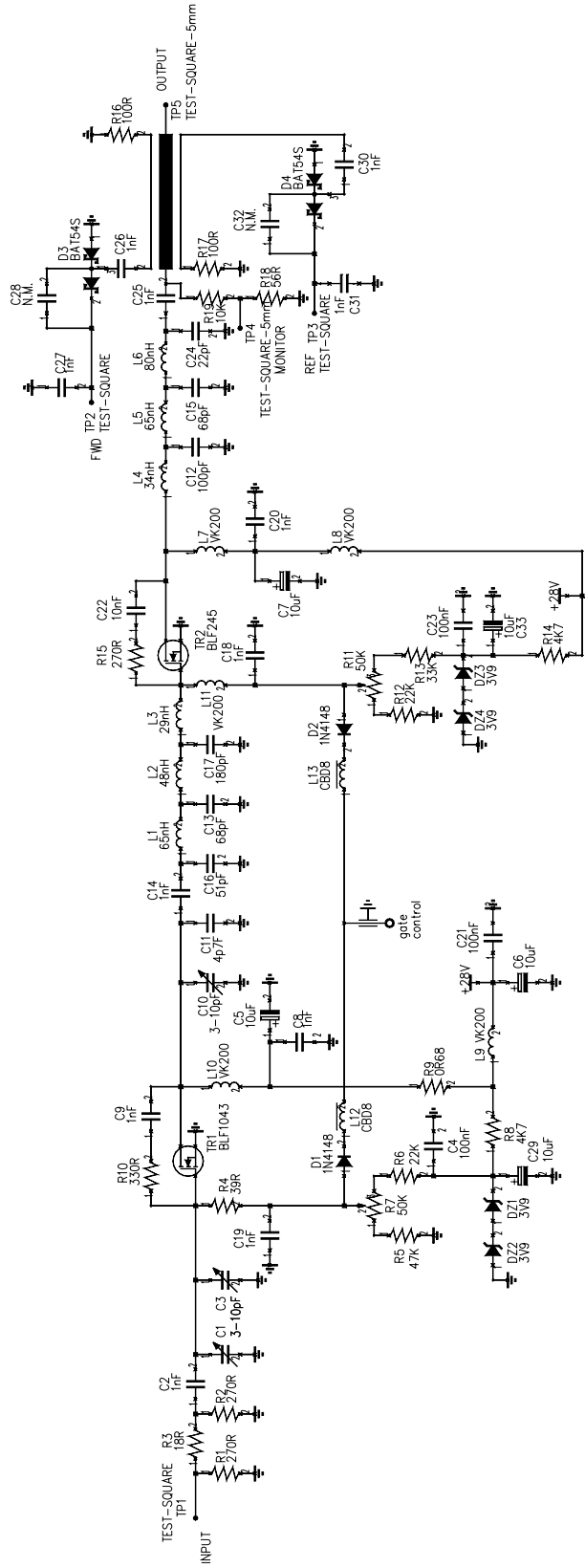

		ELECTRIC DIAGRAM		DESIGNER	CAMPANA	SIGNATURE	DATE	12/12/05
		TITLE		VHF-I RF AMPLIFIER BOARD		PCB DESIGNER	TULLO	SIGNATURE
ASSEMBLY CODE		SCH0320A				SHEET		1/1

SCH0388BR1 Component layout

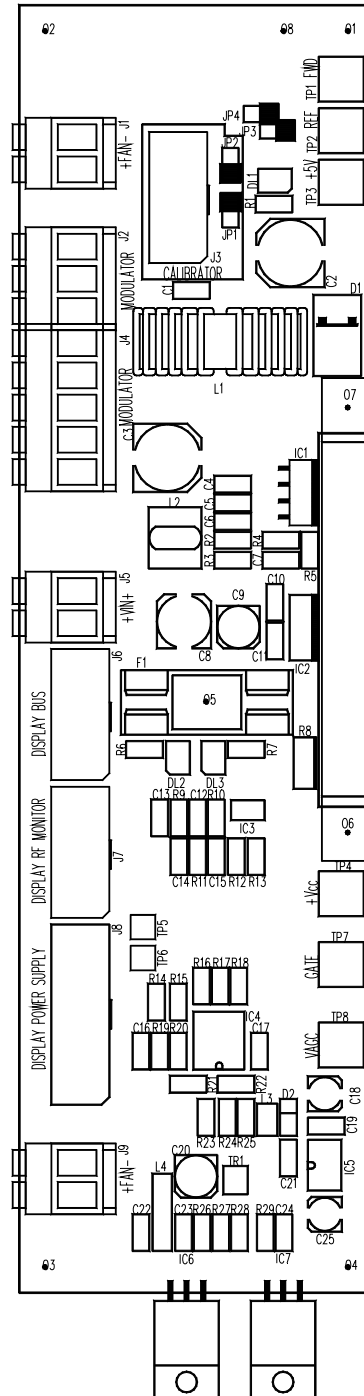

SCH0388BR1 COMPONENT LIST

Part Name/Number	Description	Qty.	Comps.
CC 100nF-S 01065C	01065C Y5V 1206 CAPACITOR	17	C1, C4-6, C10-17, C19, C21-24
CC 1206 N. M.	N. M. SMD 1206 CAPACITOR	1	C7
CE 100uF16V-S 01792A	01792A ELET. SMD CAPACITOR	1	C9
CE 10uF35V-S 01778A	01778A ELET. SMD CAPACITOR	2	C18, C25
CE 10uF50V-S 01779A	01779A ELET. SMD CAPACITOR	1	C20
CE 220uF 35V-S	01798A ELET. SMD CAPACITOR	1	C8
CE 220uF50V LOW ESR	01799A ELET. SMD CAPACITOR	2	C2-3
D 1N4148-S 03002	03002 SMD DIODE	1	D2
D 50WQ06FN	03019A SMD DIODE SCH. 5.5A	1	D1
DL KA-3528SGC 03057	03057 GREEN SMD LED DIODE	3	DL1-3
FUSE 2A-PCB 7543	7543 FUSE HOLDER+FUSE 5x2	1	F1
IC 7805 04315	04315 VOLTAGE REGULATOR	1	IC2
IC INA168	04600A SMD INTEG CIRCUIT	1	IC3
IC LM2599T-ADJ	INTEG CIRCUIT	1	IC1
IC LM317 04340	04340 INTEG CIRCUIT	1	IC6
IC LM35DT 00664	00664 INTEG CIRCUIT	1	IC7
IC LMC6484-S	04634 SMD INTEG CIRCUIT	1	IC4
IC TC7662BCOA 04758A	04758A SMD INTEG CIRCUIT	1	IC5
IND 2u2H-S 05020A	05020A INDUCTOR	1	L3
IND CBD8 05072	05072 INDUCTOR	1	L4
IND MS85 10uH-S	04948 INDUCTOR 2.7A	1	L2
IND T100uH-5A	05062A TOROIDAL-STORAGE	1	L1
J CON HD515V/05-3PVE	02893 + 02894 PANDUIT PCB	1	J2
J CON HD515V/05-5PVE	PANDUIT PCB CONNECTOR	1	J4
J FC-10P 02697-02699	02697+02699 PCB CONNEC. POL	3	J3, J6-7
J FC-16P 02701-02700	02701+02700 PCB CONNEC. POL	1	J8
JU JUMP2 02739-02742	02739+02742 MALE PAN2	4	JP1-4
R 0R02	00356 RES 20W 1%	1	R8
R 100R-1%-S 00029D	00029D RES 1/4W 1% SMD 1206	6	R9, R11, R16, R20-21, R29
R 10K-1%-S 00053B	00053B RES 1/4W 1% SMD 1206	6	R12, R19, R22, R24-25, R27
R 1206 N. M.	N. M. RES 1/4W 5% SMD 1206	1	R3
R 150K-S 00067A	00067A RES 1/4W 5% SMD 1206	1	R10
R 1K0-1%-S 00041B	00041B RES 1/4W 1% SMD 1206	2	R1, R5
R 220R-S 00033A	00033A RES 1/4W 5% SMD 1206	1	R26
R 2K7-S 00046A	00046A RES 1/4W 5% SMD 1206	1	R6
R 330R-S 00035B	00035B RES 1/4W 5% SMD 1206	1	R7
R 33K-1%-S 00059B	00059B RES 1/4W 1% SMD 1206	2	R18, R23
R 47K-1%-S 00061B	00061B RES 1/4W 1% SMD 1206	1	R14
R 560R-1%-S 00038B	00038B RES 1/4W 1% SMD 1206	1	R2
R 68K-1%-S 00063B	00063B RES 1/4W 1% SMD 1206	2	R13, R17
R 6K8-S 00051A	00051A RES 1/4W 5% SMD 1206	1	R28
R 8K2-1%-S 00052B	00052B RES 1/4W 1% SMD 1206	2	R4, R15
TR BC847 03456	03456 NPN SMD TRANSISTOR	1	TR1



MAIN FEATURES

- Universal AC input / Full range
- Built-in active PFC function, PF >0.95
- Protections: Short circuit / Over load / Over voltage / Over temp.
- Forced air cooling by built-in DC fan
- Built-in fan speed control
- Fixed switching frequency at 100kHz

MECHANICAL SPECIFICATION

PIN N°	ASSIGNMENT
--------	------------

1	AC/L
2	AC/N
3	FG \perp
4-5	DC OUTPUT -V
6-7	DC OUTPUT +V

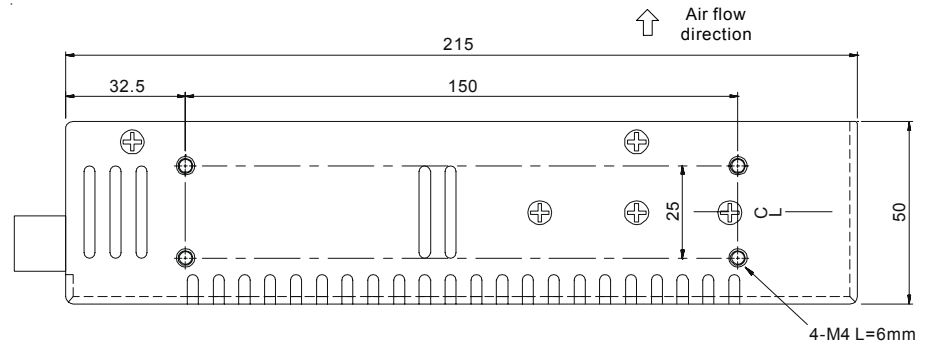
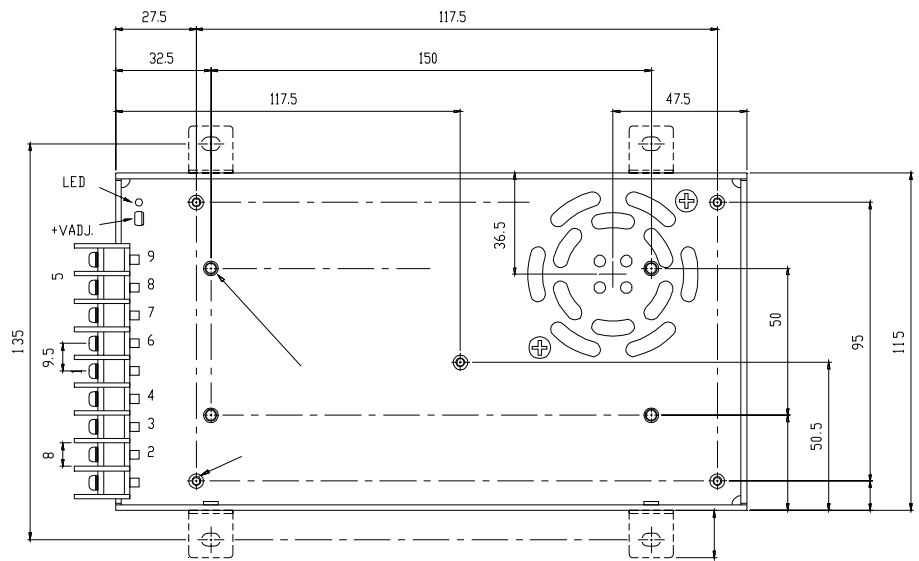

TECHNICAL CHARACTERISTICS

MODEL		SP-320-27	SP 320-48
OUTPUT	DC VOLTAGE	27V	48V
	RATED CURRENT	11.7A	6.7A
	CURRENT RANGE	0 ~ 11.7A	0 ~ 6.7A
	RATED POWER	315.9W	321.6W
	RIPPLE & NOISE (max.) Note 2	200mVp-p	240mVp-p
	VOLTAGE ADJ. RANGE	26 ~ 31.5V	41 ~ 56V
	VOLTAGE TOLERANCE Note 3	± 1.0%	± 1.0%
	LINE REGULATION	± 0.2%	± 0.2%
	LOAD REGULATION	± 0.5%	± 0.5%
	SETUP, RISE TIME	800ms, 50ms/230VAC 2500ms, 50ms/115VAC at full load	
	HOLD UP TIME (Typ.)	16ms/230VAC 124 ~ 370VDC	
INPUT	VOLTAGE RANGE	88 ~ 264VAC 124 ~ 370VDC	
	FREQUENCY RANGE	47 ~ 63Hz	
	POWER FACTOR	PF>0.95/230VAC PF>0.95/115VAC at full load	
	EFFICIENCY (Typ.)	88%	89%
	AC CURRENT	5A/115VAC 2.5A/230VAC	
	INRUSH CURRENT (Max.)	20A/115VAC 40A/230VAC	
	LEAKAGE CURRENT	<1mA/240VAC	
PROTECTION	OVER LOAD	105 ~ 135% rated output power Protection type: Hiccup mode, recovers automatically after fault condition is removed	
	OVER VOLTAGE	33.7 ~ 39.2V	57.6 ~ 67.2V
		Protection type: Hiccup mode, recovers automatically after fault condition is removed	
	OVER TEMPERATURE	80°C ±5°C (70°C ±5°C 3.3V, 5V only) (TSW1: Detect on heat sink of power transistor) Protection type: Shut down o/p voltage, recovers automatically after temperature goes down)	
ENVIRONMENT	WORKING TEMP.	-20 ~ +65°C (Refer to output load derating curve)	
	WORKING HUMIDITY	20 ~ 90% RH non-condensing	
	STORAGE TEMP., HUMIDITY	-40 ~ +85°C, 10 ~ 95% RH	
	TEMP. COEFFICIENT	± 0.03%/°C (0 ~ 50°C)	
	VIBRATION	10 ~ 500Hz, 2G 10min./1cycle, period for 60min. each along X, Y, Z axes	
SAFETY & EMC (Note 4)	SAFETY STANDARDS	UL60950-1, TUV EN60950-1 Approved	
	WITHSTAND VOLTAGE	I/P-O/P:3KVAC I/P-FG:1.5KVAC O/P-FG:0.5KVAC	
	ISOLATION RESISTANCE	I/P-O/P, I/P-FG, O/P-FG:100M Ohms/500VDC	
	EMI CONDUCTION & RADIATION	Compliance to EN55022 (CISPR22) Class B	
	HARMONIC CURRENT	Compliance to EN61000-3-2,-3	
	EMS IMMUNITY	Compliance to EN61000-4-2,3,4,5,6,8,11; ENV50204, Light industry level, criteria A	
OTHERS	MTBF	207K hrs min. MIL-HDBK-217F (25°C)	
	DIMENSION	215*115*50mm (L*W*H)	
	PACKING	1.1kg	



S.S. 96 km 113 - Zona Industriale
70027 PALO DEL COLLE (Bari)
ITALY

Phone: +39 080 626755
Fax: +39 080 629262

www.elettronika.it
elettronika@elettronika.it