

Section 4 - Diagram

Contents:

- Cable diagram
- APT159A AUTV/500LD Power Supply Section
- APT159A AUTV/500LD RF Section
- APT159A AUTV/500LD Lateral View
- MTF0083AR0 Amplifier module - Component list
- SCH0192AR0 (200W UHF LDMOS Amplifier module)
- SCH0259AR0 (RF Amplifier interface)
- SCH0223AR1 (Control board and display)
- SCH0288AR0 (Amplifier interface)
- SCH0265AR0 (Mains distribution board)
- E0012 (SP500-27-DI Switching power supply)

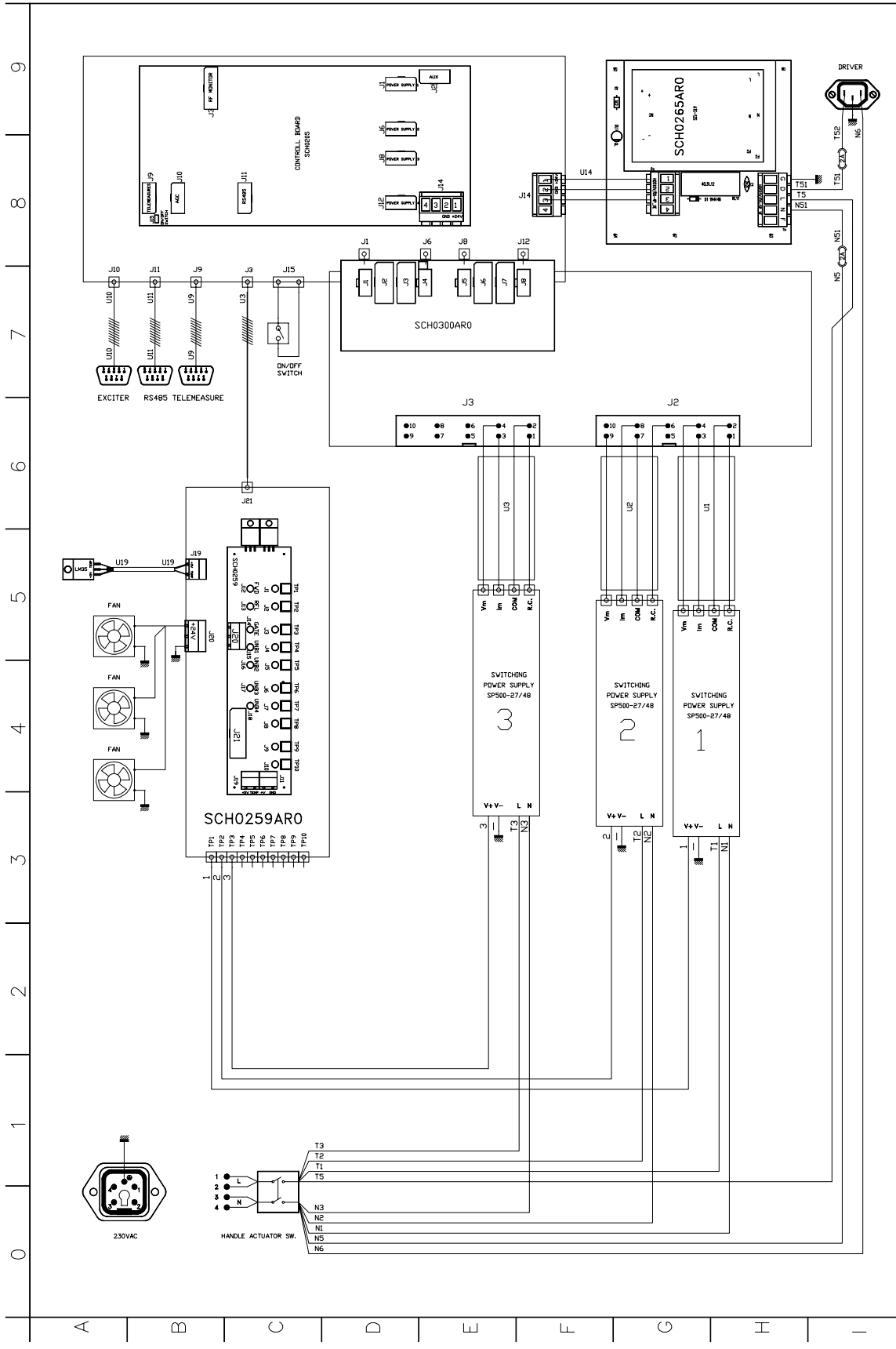

	ASSEMBLY CODE APT1159A	TITLE AUTV/500LD LDMOS UHF TV AMPLIFIER	DESIGNER COLASUONNO	PROB DESIGNER COLASUONNO	DATE 20/01/2005	PCB REF APT159A_AUTV/500LD.dwg
	COMPONENT LAYOUT		SIGNATURE	SIGNATURE	SHEET 1 OF 3	

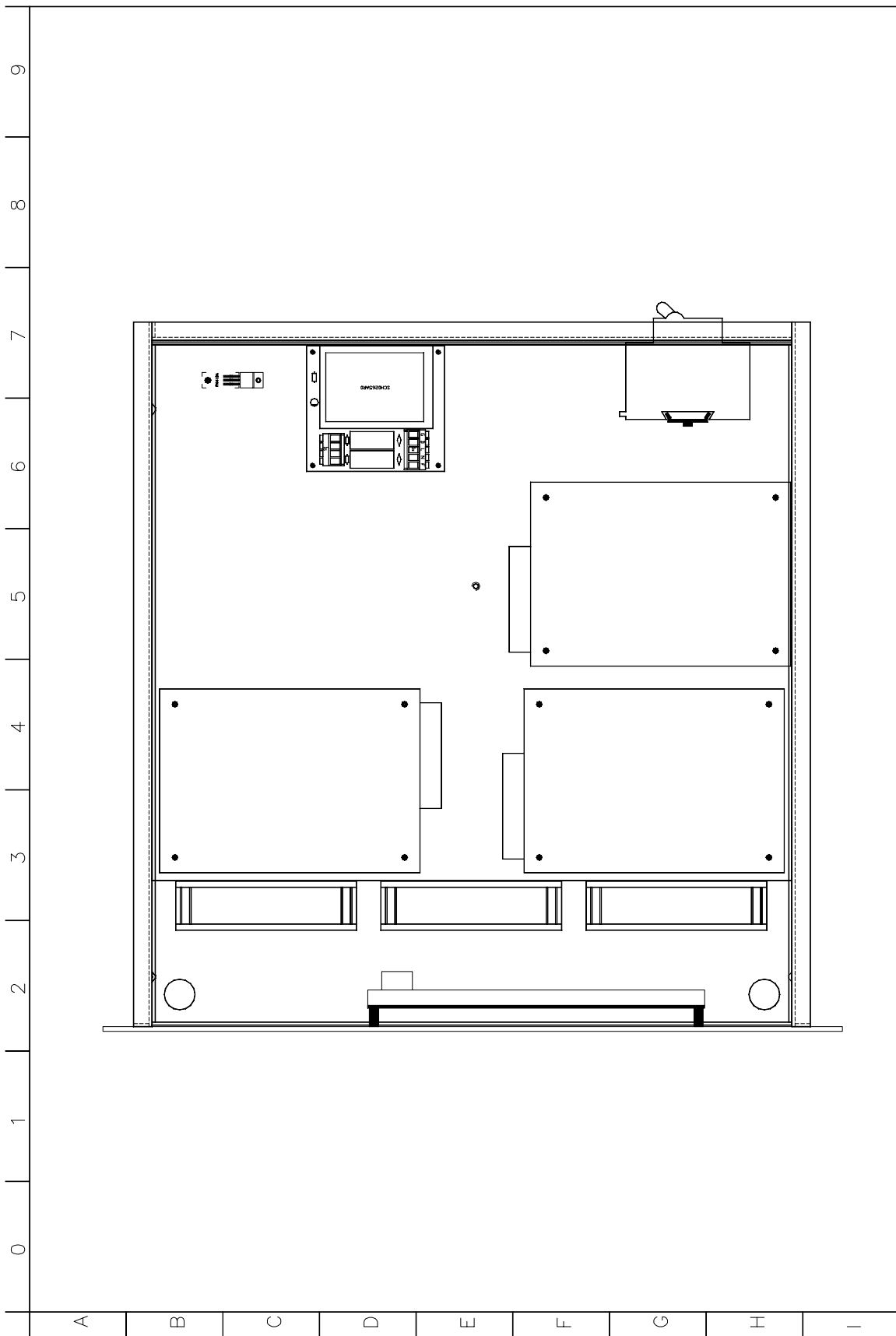

ELSTRONIKA s.r.l. ASSEMBLY CODE APT1159A	COMPONENT LAYOUT TITLE AUTY/500LD LDMOS UHF TV AMPLIFIER	DESIGNER COLASUONNO	SIGNATURE	DATE 20/01/2005
		PCB DESIGNER COLASUONNO	SIGNATURE	PCB REF APT159A_AUTY/500LD.dwg
		SHEET 1 OF 3		

0 1 2 3 4 5 6 7 8 9

A

B

C

D

E

F

G

H

I

L

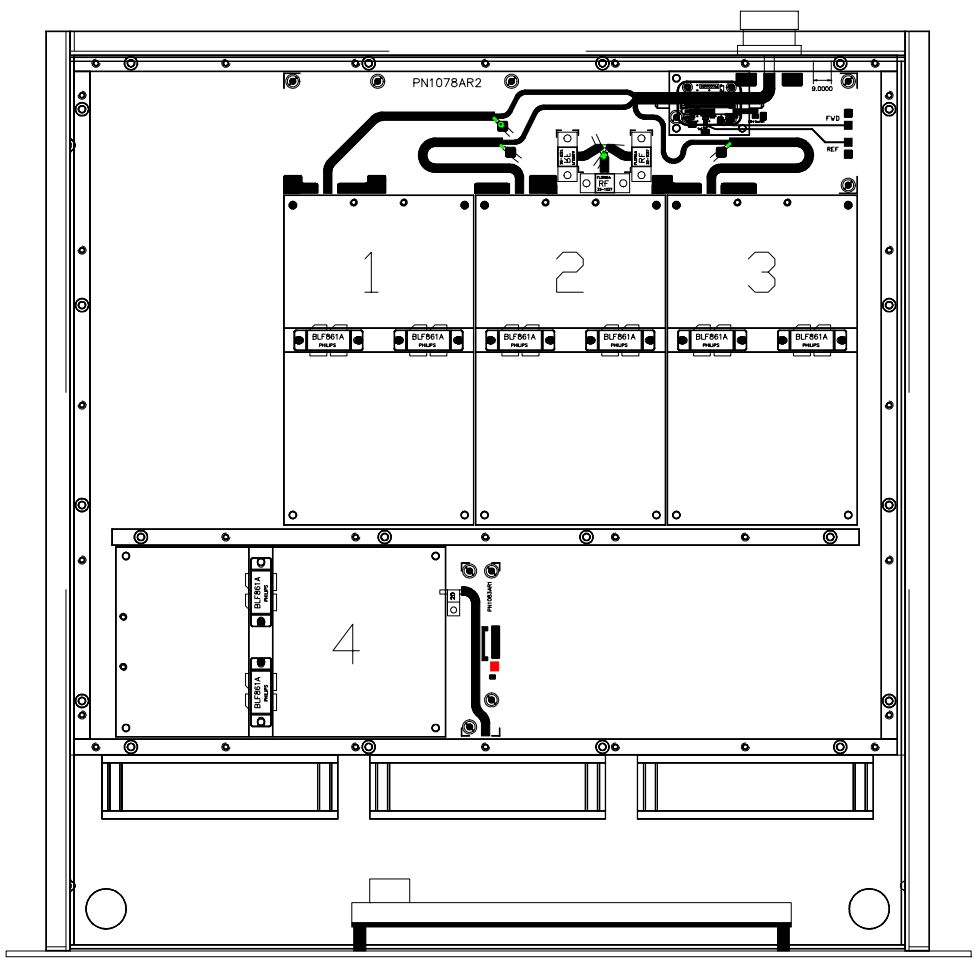

ASSEMBLY CODE
APT1159A

COMPONENT LAYOUT

TITLE
AUTV/500LD - RF SECTION

DESIGNER
COLASUONNO

PCB DESIGNER
COLASUONNO

SIGNATURE

SIGNATURE

DATE 20/01/2005
PCB REF
APT108A_AUTV/500LD.dwg

SHEET 2 OF 3

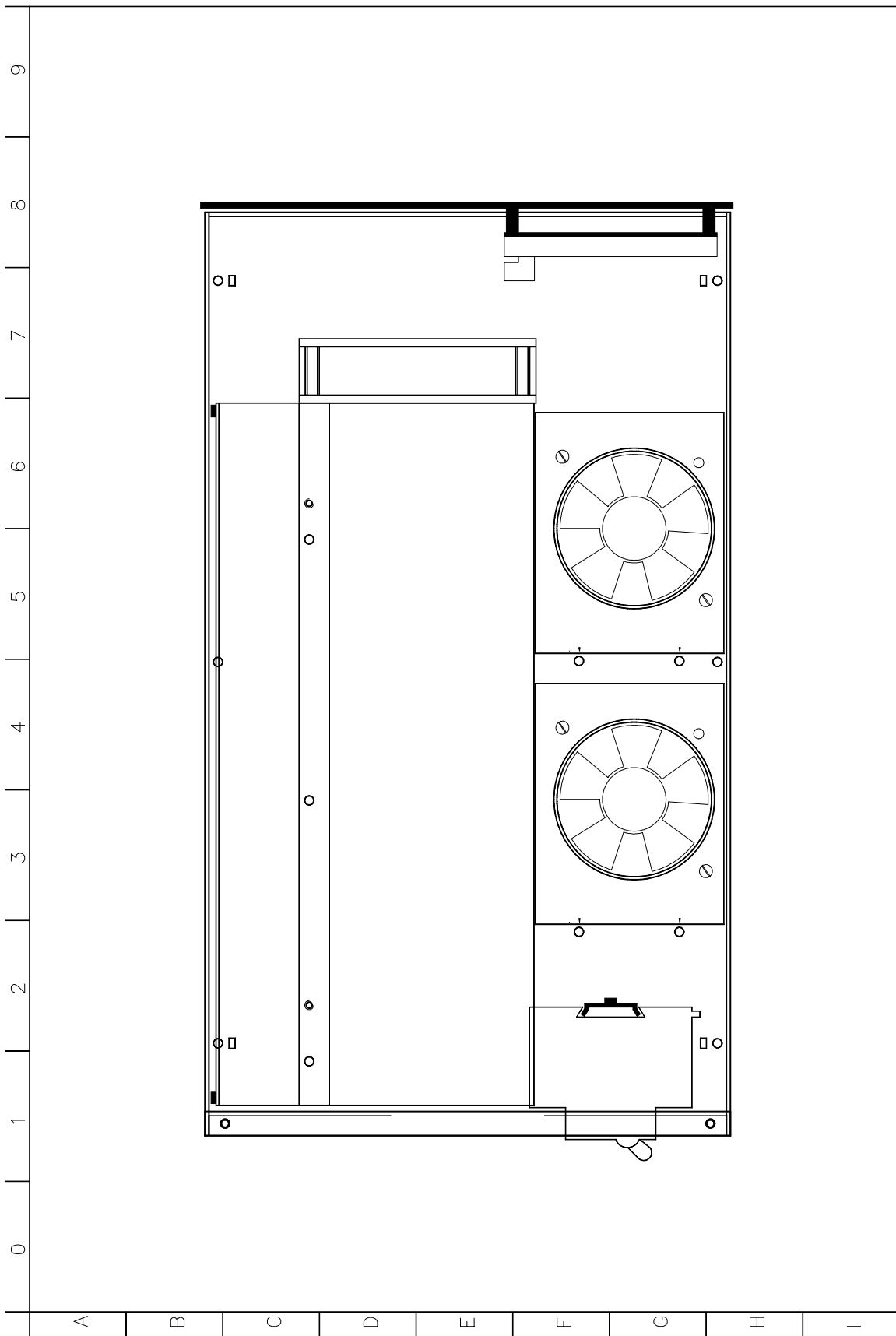

ELSTRONIKA s.r.l. ASSEMBLY CODE APT1159A	TITLE AUTY/500LD - LATERAL VIEW	DESIGNER COLASUONNO	SIGNATURE	DATE 20/01/2005
	PCB REF APT159A_AUTY/500LD.dwg	PCB DESIGNER COLASUONNO	SIGNATURE	SHEET 3 OF 3

Component list**MTF0083AR0 Amplifier module**

Part Name Code	Description	Qty
08502	RG316 50Ω CABLE	1,30
08521	RG179 BU 75Ω CABLE	0,27
08527	HF-85 ENDIFORM CABLE	0,25
00028A	82Ω 1206 SMD RESISTOR	1
01096	1nF CHIP MULT. 2222 863 15102	3
03207	HSMS-2802*TR1 DIODE	3
07904	PASSANTINI TO3 cod. 672.1607	2
07907	MICA x TO22 cod. 542-2822	2
SCH0192AR0	200W LDMOS UHF AMPLIFIER MODULE	4
SCH0295AR0	INTERFACE BOARD	1
PN0998A	C.S. PN998AR1 SOMMATORE ALIMENTATORE	1
PN1079A	C.S. PN1079AR2 DIVISORE IN 3 VIE 500W UHF	1
PN1078A	C.S. PN1078AR4 COMBIN. D'USCITA x 500W UHF	1
PN1083A	C.S. PN1083AR2 ACCOPPIATORE INGRESSO 1500W	1
02402	7/16" FEMMINA ANIM. FILET. cod. 0142	1
02512	J01151A0531 PRESA SMA SEN. BAT.	1
01041	1nF COND. CERAMICO 50V	2
01400	C. PAS. 2499-003-X5U0-102M	8
00424	TERMINAZIONE 50Ω 250W 32-1037-50-5	3
DET0868	DET0868R0 SPESS. ACC. DIR. ING. 1000W UHF	1
DET0842	DET0842R4 DISSIPATORE 700W UHF LDMOS	1
DET0843	DET0843R1 SPOND. LAT. 700W UHF LDMOS	2
DET0844	DET0844 SPOND. ANT. 700W UHF LDMOS	1
DET0845	DET0845R2 SPOND. POST. 700W UHF LDMOS	1
DET0846	DET0846R2 SPOND. CENTR. 700W UHF LDMOS	1
DET0847	DET0847R1 SPESSORE x PN1078A	1
DET0849	DET0849R1 CHIUS. 700W UHF LDMOS P.2670	1
00383	1W SMD RESISTOR 2512 100R 224/0272	6
00403	270Ω 1W SMD RESISTOR 2512 1%	6
00436	ATTENUATORI 20W PPA 20.6	1
00027A	68Ω 1206 SMD RESISTOR	2
00041A	1kΩ 1206 SMD RESISTOR 5%	2
03017	MBR3045PT DIODE	2
07911	MICA IN SIL-PAD x TO3P VA001080	2
07910	PASSANTE x TO220 cod. 672/1606	2
PN1210A	C.S. PN1210AR2 ACCOPPIATORE DIREZIONALE	1
DET0805	DET0805R4 PARTICOLARE PRELIEVO MONITORIA	1
DET1059	DET1059R0 ANELLO IN TEFLON x ACCOP. DIREZ.	2
DET0813	DET0813R1 LINEA PART. PRELIEVO MONITORIA	1
DET1058	DET1058R0 CHIUSURA x ACCOP. DIREZIONALE	1
0148	C. PAS. 5000PF	2

Component list**APT159B - AUTV/500LD**

Part Name Code	Description	Qty
05570	GUIDE FOR RACK TAV. 816RB RKG6 560mm ZN	4
05578	RACK 20U RK20 600mm DEPTH	1
APT159A	AUTV/500LD LDMOS UHF AMPLIFIER MEANWELL	1
02502	SMA SOCKET FOR RG58/c J01150A0041	1
08504	RG58 50Ω CABLE	1
CMS6006	1/2" FORM 1mt CABLE 7/16" (M) CONN. BN203391	1
02029	GE35145 D/60 BN (UG909/c FOR RG58)	1
CSS5011	RG58 FROM 1.5mt NM/NM CABLE	1
DET0483	DET0483R0 BAR. PR. 683 REG. PCAV ZN P. 2557	2
DET0631	DET0631R1 ANGOL. FISS. FILTRO FOR 300W CINA	2
PAN0080	PAN0080R0 PANN. FRONT. 1U CON POLICARB.	1
PAN0081	PAN0081R0 PANN. FRONT. 2U CON POLICARB.	2
PAN0082	PAN0082R0 PANN. FRONT. 3U CON POLICARB.	2
06673	500W UHF BANDPASS FILTER mod. CL3NL6	1

This page is intentionally blank

DESCRIPTION

The RF module is an integrated TV linear amplifier designed for UHF band, this module employs push-pull LDMOS technology in order to achieve very good efficiency, high linearity and reliability.

LDMOS transistors operate in AB class. It is a wideband amplifier over the full frequency, no adjustment is required for the channel change. The board includes RF section amplifier, bias circuit, protection circuit and matching networks. A silver plated copper plate is brazed with PCB in order to obtain low thermal resistance. Providing a minimum of 200W Pk sync linear power, this module is the perfect amplifier for any broadband UHF power transmitter.

TECHNICAL CHARACTERISTICS

Output power	300W max
Input power	15W max
Frequency	470 - 860MHz
Gain	> 13dB
LDMOS Power supply	32V±2%
LDMOS Bias current @+32V Vdc	2A
RF Input impedance	50Ω
RF Output impedance	50Ω
Input / Output return loss	>= 15dB
Drain efficiency	47% @ 250W
Storage temperature range	-50° to +150°C
Dimensions (LxWxH)	165x95x29mm

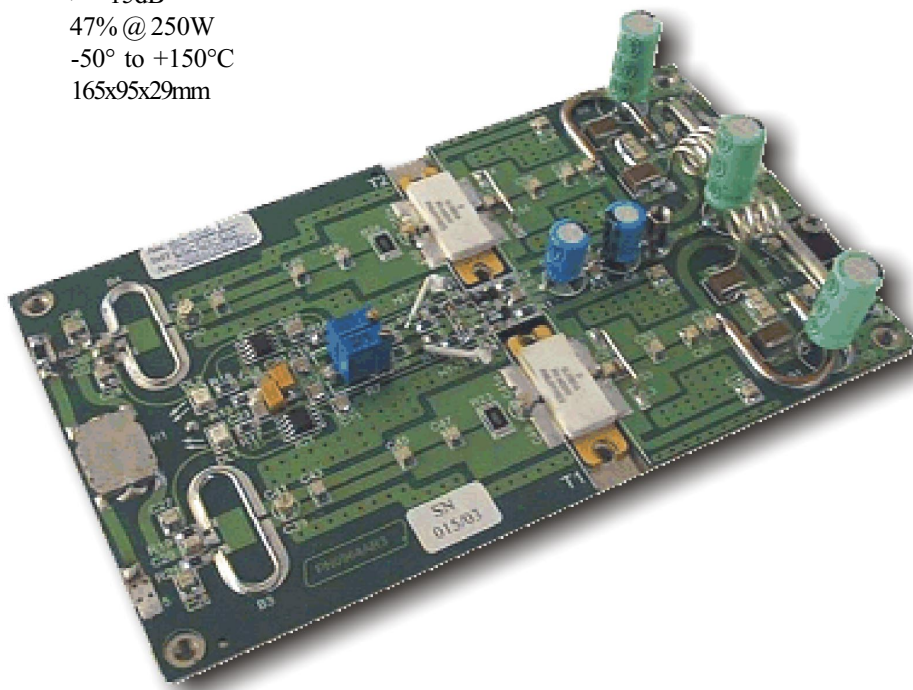

- Curve response graphic

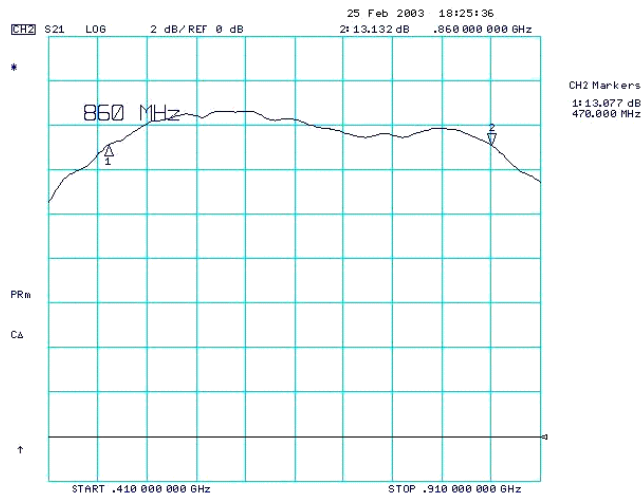

Middle frequency 660MHz, span 500MHz, 2dB/div., reference to the arrow

CALIBRATION PROCEDURE

- Technical characteristics

Power supply voltage	32V ($\pm 2\%$)
Polarisation current	1.0 cold for each device (2A total), $\pm 0.1A$
Gain for low signal	Not less than 13dB in the 470-860MHz band ($\pm 1dB$) Compare to the typical curve enclosed

- Adjustment procedure

Polarisation current calibration	32V stabilised power supply 10A amperometer
Gain curve	Network analyser

- Adjustment points description

R7-R8 (Trimmers)	Adjust the current absorbed in stand-by (1.0A per device)
------------------	---

- Calibration steps

STEP 1. **Close the input and the output of the module by connecting them to a 50Ω dummy load** and connect the spectrum analyser through a directive sample, in order to look for self-oscillation of the module, if any (anyway the module has been designed so that it would not self-oscillate even if totally decoupled, without any input or output load).

STEP 2. **Check the voltages of the polarisation circuits *without assembling the transistors first*:** connect the 32V power supply to the proper turret by means of a fastening screw, then give power and check data:

- the stabilised voltage on the zener diodes DZ1 and DZ2 is about 15V compared to the ground;
- the stabilised voltage on the zener diodes DZ3 and DZ4 is about 6.8V compared to the ground;
- the voltage on the pads to which the gates of the LDMOS transistors will be soldered (R23 and R24 resistors side) changes from 0V to a maximum value of about 6V when moving the relevant trimmer (R7-R8).

STEP 3. **Check the work of the protections.**

- Set both trimmers so that there is a value of about 4.5V on the pads of the gates;
- solder some wire to the pad between the two LEDs, next to the serigraphy of the input hybrid H1;

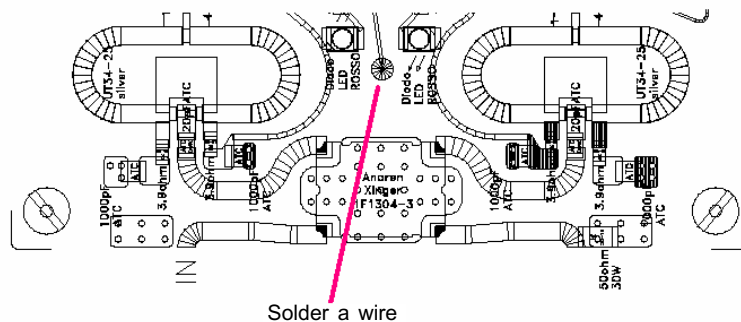

- in order to check the work of the protections aboard, a power of about 4V has to be supplied to the wire, for example by touching with it the reophore of C23 or C24 which is not connected to ground; the two red LEDs will immediately light up and the two RF transistors will be switched off at the same time: the polarisation current (2A) will decrease to 0 and of course the gain curve displayed by the spectrum analyser will decrease;
- after this it is **important** to *restore the position of the two trimmers for the minimum voltage!* Then disconnect the 32V power supply.

STEP 4. **Fastening of the LDMOS transistors:** after properly cleaning the plate surface, smear a thin layer of silicone fat on the lower side of the flange of the MOSFETs, fasten them to the heat sink and solder the gate first, then the drain. Solder the two 13pF (ATC) chip capacitors and above them the two 1-5pF

capacitive trimmers, between the two pair of gates, as shown by the mounting plan.

STEP 5. Connect serially a c.c. amperometer to the power supply, with scale starting from more than 5A (i.e. 10A).

STEP 6. Power the module and check the MOSFET is not absorbing current; this means that the device is integral and working correctly.

STEP 7. Slowly turn the R7 trimmer until the MOSFET absorbs 1A, always checking that there are no self-oscillation; under this conditions it is possible to check by means of a digital tester that the voltage on the gate is about 5.2-5.4V.

STEP 8. Repeat the previous step for the other section of the module, this time turnign R8 and checking that the indication of the current on the amperometer increases to 2A total (which includes the current of the other device left on).

STEP 9. Check the response curve of the module by means of the *network analyser*.

STEP 10. Check the response curve for low signal with centre 660MHz and span 500MHz, 2dB/div.

STEP 11. The curve should be similar to the one enclosed, with a tolerance of ± 0.5 dB. To obtain this, act on the four trimmers C41-C41a and C42-C42a with the proper “calibrator”, in order to flatten the curve as much as possible, especially at the edged of the band which represents the minimum values.

STEP 12. Finally, check that the current in stand-by does not increase by more than 15÷20%, reaching at worst 2.3÷2.4A when the heat sink is hot and not ventilated.

Note: when mounting-removing the PALLET on the heat sink, tightly fasten the screw of each all “N” input and output connectors. These are mounted with a single 3mm screw and if it is not properly fastened it may be detached from the PCB by a movement of the connector once it has already been soldered to the path.

Component layout SCH0192AR0

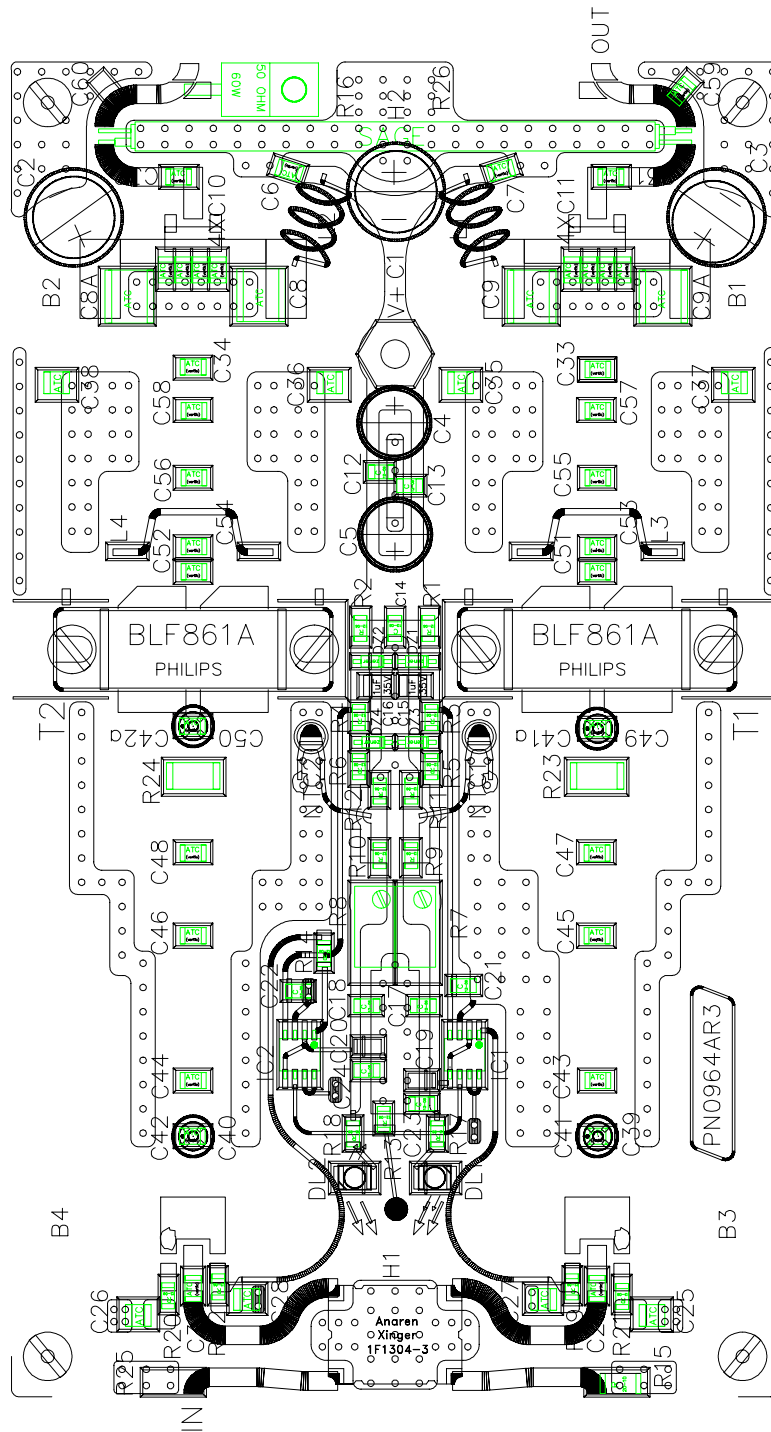

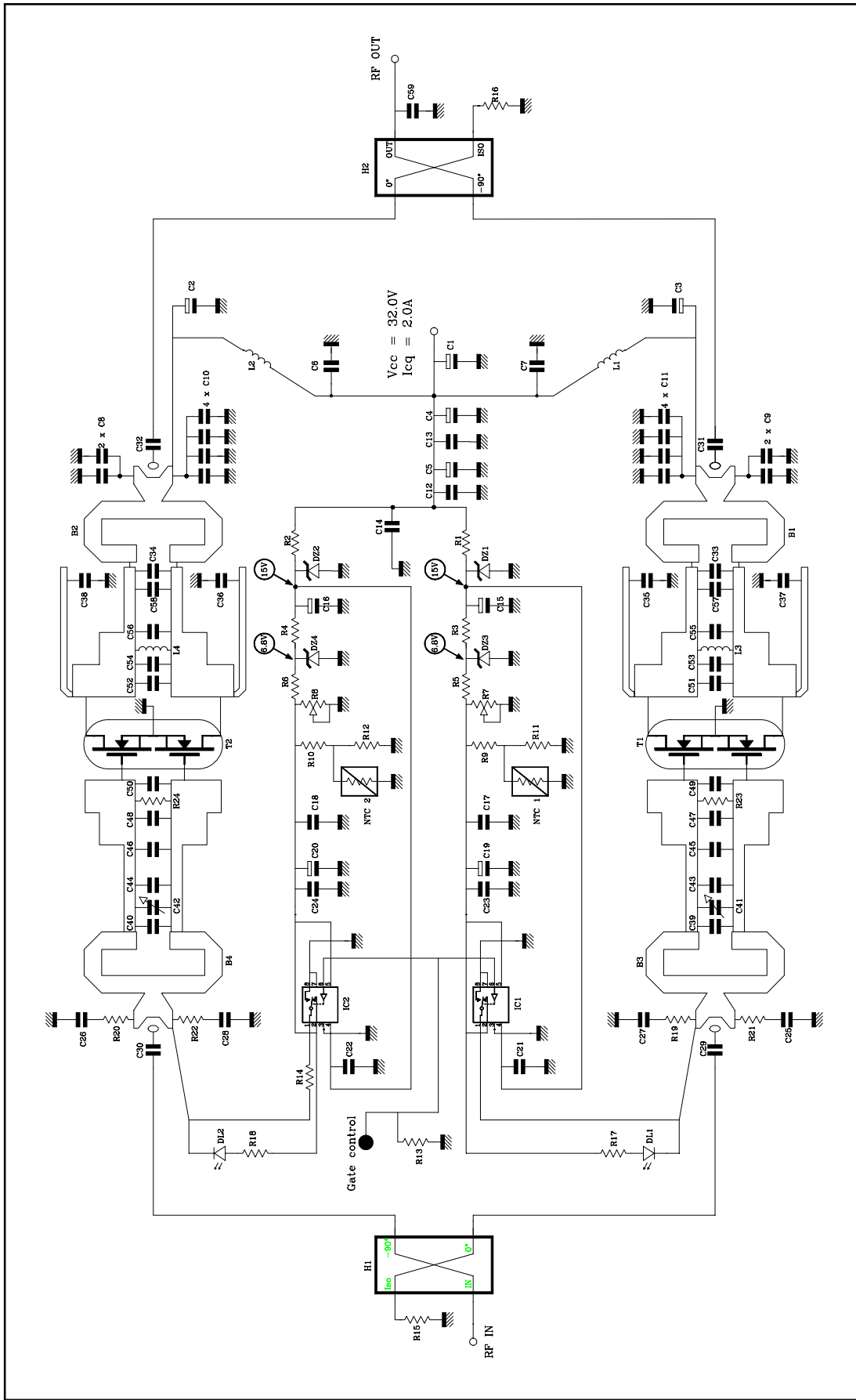

ELSTRONIKA S.p.A. CODICE SCH0192ARO	DESCRIPTION Schema Elettrico MODULO AMPLIFICATORE 200W LDMOS	DESIGNER VACCA	SIGNATURE SIGNATURE	DATE 13/12/03
	TITLE 200W LDMOS AMPLIFIER MODULE Electric Diagram	PCB DESIGNER VACCA	SIGNATURE SIGNATURE	REF. SHEET 1/1
		QUALITY CONTROL —		

COMPONENT LIST SCH0192AR0

REF.	DESCRIPTION	ELETTRONIKACODE	Page 1/3
R1	2200Ω 1/4W 1206 SMD RESISTOR	00045A	
R2	2200Ω 1/4W 1206 SMD RESISTOR	00045A	
R3	2200Ω 1/4W 1206 SMD RESISTOR	00045A	
R4	2200Ω 1/4W 1206 SMD RESISTOR	00045A	
R5	1200Ω 1/4W 1206 SMD RESISTOR	00042A	
R6	1200Ω 1/4W 1206 SMD RESISTOR	00042A	
R7	50kΩ MULTITURNS PTH TRIMMER	00800	
R8	50kΩ MULTITURNS PTH TRIMMER	00800	
R9	1200Ω 1/4W 1206 SMD RESISTOR	00042A	
R10	1200Ω 1/4W 1206 SMD RESISTOR	00042A	
R11	18kΩ 1/4W 1206 SMD RESISTOR	00056B	
R12	18kΩ 1/4W 1206 SMD RESISTOR	00056B	
R13	680KΩ 1/4W 1206 SMD RESISTOR	00075A	
R14	0Ω 1/4W 1206 SMD RESISTOR	00001	
R15	50Ω 30W 1512EBX SMD RESISTOR	00416A	
R16	50Ω 60W	00432	
R17	4.7kΩ 1/4W 1206 SMD RESISTOR	00049A	
R18	4.7kΩ 1/4W 1206 SMD RESISTOR	00049A	
R19	3.9Ω 1/4W 1206 SMD RESISTOR	00012A	
R20	3.9Ω 1/4W 1206 SMD RESISTOR	00012A	
R21	3.9Ω 1/4W 1206 SMD RESISTOR	00012A	
R22	3.9Ω 1/4W 1206 SMD RESISTOR	00012A	
R23	1000Ω 1W 2512 SMD RESISTOR	00396	
R24	1000Ω 1W 2512 SMD RESISTOR	00396	
*R25	= R15 (da montare se si inverte l'ingresso)		
*R26	= R26 (da montare se si inverte l'uscita)		
C1	470uF 50V PTH ELECTROLYTIC CAPACITOR	01807B	
C2	470uF 50V PTH ELECTROLYTIC CAPACITOR	01807B	
C3	470uF 50V PTH ELECTROLYTIC CAPACITOR	01807B	
C4	100uF 50V PTH ELECTROLYTIC CAPACITOR	01795	
C5	100uF 50V PTH ELECTROLYTIC CAPACITOR	01795	
C6	1nF ATC 100B CAPACITOR OR EQUIVALENT	01145	
C7	1nF ATC 100B CAPACITOR OR EQUIVALENT	01145	
C8 x2	2 x 100nF ATC CAPACITOR OR EQUIVALENT	01065H	
C9 x2	2 x 100nF ATC CAPACITOR OR EQUIVALENT	01065H	
C10 x4	4 x 100pF ATC 100B CAPACITOR OR EQUIVALENT	01135	
C11 x4	4 x 100pF ATC 100B CAPACITOR OR EQUIVALENT	01135	
C12	100nF 1210 SMD CAPACITOR	1065G	
C13	100nF 1210 SMD CAPACITOR	1065G	
C14	100nF 1210 SMD CAPACITOR	1065G	
C15	1uF 35V SMD TANTALIUM CAPACITOR	01613A	
C16	1uF 35V SMD TANTALIUM CAPACITOR	01613A	
C17	100nF 1210 SMD CAPACITOR	1065G	

REF.	DESCRIPTION	ELETTRONIKA CODE	Page 2/3
C18	100nF 1210 SMD CAPACITOR	1065G	
C19	10uF 16V SMD TANTALIUM CAPACITOR	01626A	
C20	10uF 16V SMD TANTALIUM CAPACITOR	01626A	
C21	100nF 1210 SMD CAPACITOR	1065G	
C22	100nF 1210 SMD CAPACITOR	1065G	
C23	100nF 1210 SMD CAPACITOR	1065G	
C24	100nF 1210 SMD CAPACITOR	1065G	
C25	1nF ATC 100B CAPACITOR OR EQUIVALENT	01145	
C26	1nF ATC 100B CAPACITOR OR EQUIVALENT	01145	
C27	1nF ATC 100B CAPACITOR OR EQUIVALENT	01145	
C28	1nF ATC 100B CAPACITOR OR EQUIVALENT	01145	
C29	20pF ATC 100B CAPACITOR OR EQUIVALENT	01123	
C30	20pF ATC 100B CAPACITOR OR EQUIVALENT	01123	
C31	20pF ATC 100B CAPACITOR OR EQUIVALENT	01123	
C32	20pF ATC 100B CAPACITOR OR EQUIVALENT	01123	
C33	1.3pF ATC 100B CAPACITOR OR EQUIVALENT	01104	
C34	1.3pF ATC 100B CAPACITOR OR EQUIVALENT	01104	
C35	470pF ATC 100B CAPACITOR OR EQUIVALENT	01143	
C36	470pF ATC 100B CAPACITOR OR EQUIVALENT	01143	
C37	470pF ATC 100B CAPACITOR OR EQUIVALENT	01143	
C38	470pF ATC 100B CAPACITOR OR EQUIVALENT	01143	
C39	4.7pF ATC 100B CAPACITOR OR EQUIVALENT	01108	
C40	4.7pF ATC 100B CAPACITOR OR EQUIVALENT	01108	
C41 x 2	2 x 1÷5pF JOHANSON SMD TRIMMER	1485	
C42 x 2	2 x 1÷5pF JOHANSON SMD TRIMMER	1485	
C43	3.6pF ATC 100B CAPACITOR OR EQUIVALENT	01104B	
C44	3.6pF ATC 100B CAPACITOR OR EQUIVALENT	01104B	
C45	6.8pF ATC 100B CAPACITOR OR EQUIVALENT	01111	
C46	6.8pF ATC 100B CAPACITOR OR EQUIVALENT	01111	
C47	6.8pF ATC 100B CAPACITOR OR EQUIVALENT	01111	
C48	6.8pF ATC 100B CAPACITOR OR EQUIVALENT	01111	
C49	13pF ATC 100B CAPACITOR OR EQUIVALENT	01119A	
C50	13pF ATC 100B CAPACITOR OR EQUIVALENT	01119A	
C51	8.2pF ATC 100B CAPACITOR OR EQUIVALENT	01113	
C52	8.2pF ATC 100B CAPACITOR OR EQUIVALENT	01113	
C53	8.2pF ATC 100B CAPACITOR OR EQUIVALENT	01113	
C54	8.2pF ATC 100B CAPACITOR OR EQUIVALENT	01113	
C55	10pF ATC 100B CAPACITOR OR EQUIVALENT	01117	
C56	10pF ATC 100B CAPACITOR OR EQUIVALENT	01117	
C57	4.7pF ATC 100B CAPACITOR OR EQUIVALENT	01108	
C58	4.7pF ATC 100B CAPACITOR OR EQUIVALENT	01108	
C59	0.3pF ATC 100B CAPACITOR OR EQUIVALENT	01160	
T1	BLF861A RF LDMOS POWER TRANSISTOR	04034	
T2	BLF861A RF LDMOS POWER TRANSISTOR	04034	
B1	COAX 2:1 BALUN	08491	

REF.	DESCRIPTION	ELETTRONIKA CODE	Page 3/3
B2	COAX 2:1 BALUN	08491	
B3	COAX 4:1 BALUN	08492	
B4	COAX 4:1 BALUN	08492	
L1	4 TURNS SILV. COP. WIRE 1.2mm WOUND ON OD 5mm	07684	
L2	4 TURNS SILV. COP. WIRE 1.2mm WOUND ON OD 5mm	07684	
L3	½ TURN COIL		
L4	½ TURN COIL		
H1	HYBRID COUPLER 3dB 90° ANAREN	05368	
H2	HYBRID COUPLER 3dB 90° SAGE	05369	
NTC1	NTC 100KΩ PTH	00661	
NTC2	NTC 100KΩ PTH	00661	
IC1	DG419DY	04583	
IC2	DG419DY	04583	
DZ1	15V SMD ZENER DIODE	03135	
DZ2	15V SMD ZENER DIODE	03135	
DZ3	6.8V SMD ZENER DIODE	03137	
DZ4	6.8V SMD ZENER DIODE	03137	
DL1	SMD LED DIODE - RED -	03056	
DL2	SMD LED DIODE - RED -	03056	
PN964AR3	PCB	0643K	
	Torretta 3x10 f/f	V0774	
	Imballo velapack 200x125x50	09983	

Component layout SCH0259A0

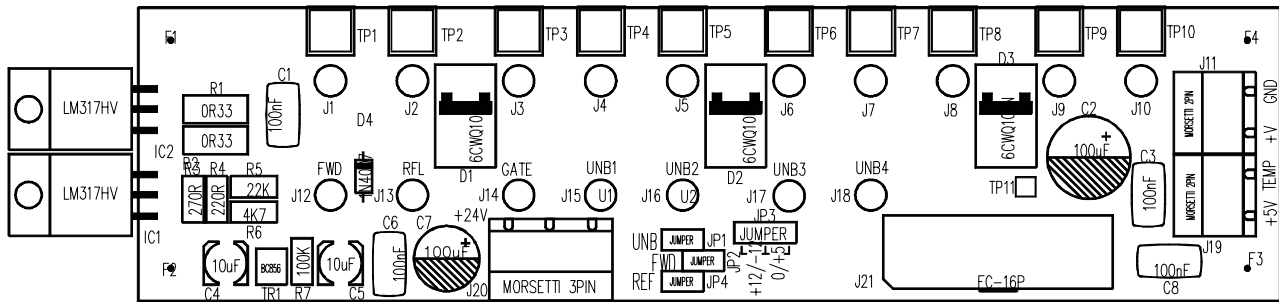

COMPONENT LIST SCH0259A0

Part Name/Number	Description	Qty.	Comps.
CC 100nFAVX 01065A	01065A CERAMIC COND	4	C1, C3, C6, C8
CE 100uF100V	01795B ELETT. COND.	1	C2
CE 100uF50V 01795	01795 ELETT. COND.	1	C7
CE 10uF35V-S 01778A	01778A ELETTR SMD COND	2	C4-5
D 1N4007 03009	03009 DIODE	1	D4
D 6CWQ10FN	03026 SMD DIODE SCHOTTKY 3,5A	3	D1-3
IC LM317HV	04340A INTEG CIRCUIT	2	IC1-2
JFC-16P 02701-02700	02701+02700 PCB CONNECTOR POL	1	J21
J SCREWCONN2 02853	02853 PCB SCREW CONNECTOR	2	J11, J19
J SCREWCONN3 02860	02860 PCB SCREW CONNECTOR	1	J20
J TESTP1.3mm 07913	07913 TEST POINT	17	J1-10, J12-18
JU JUMP2 02739-02742	02739+02742 MASCHIO PAN2	3	JP1-2, JP4
JU JUMP3 02707-02742	02707+02742 MASCHIO PAN3	1	JP3
R 0R33-1W-S	00380 RES 1W 5% SMD 2512	2	R1-2
R 100K-S 00065A	00065A RES 1/4W 5% SMD 1206	1	R7
R 220R-S 00033A	00033A RES 1/4W 5% SMD 1206	1	R4
R 22K-S 00057A	00057A RES 1/4W 5% SMD 1206	1	R5
R 270R-S 00034A	00034A RES 1/4W5% SMD 1206	1	R3
R 4K7-S 00049A	00049A RES 1/4W 5% SMD 1206	1	R6
TR BC856 03455	03455 PNP SMD TRANSISTOR	1	TR1

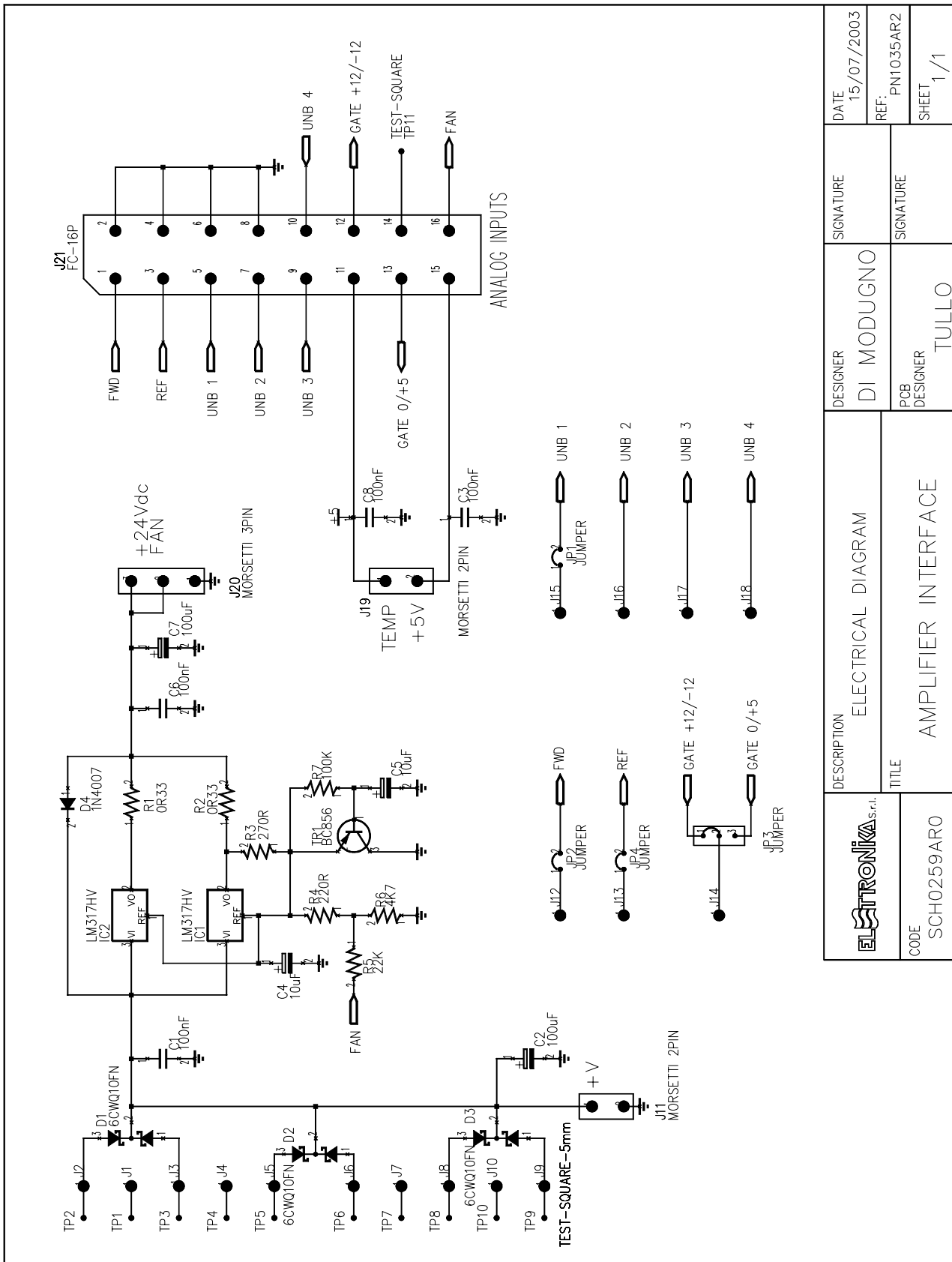

DESIGNER DI MODUGNO	SIGNATURE	DATE	15/07/2003
		REF.	PN1035AR2
PCB DESIGNER TULLO	SIGNATURE	SHEET 1/1	
		DESCRIPTION ELECTRICAL DIAGRAM	
TITLE AMPLIFIER INTERFACE		CODE SCH0259AR0	

DESCRIPTION

The control board SCH0223AR1 manages the operational logic of the amplifier: switching on and off, power supply and fans, alarms and protections, remote control, human-machine interface. All of that is performed by a modern and powerful 16 bit micro-controller, which is the main part of the board.

Figure 1 shows the block diagram.

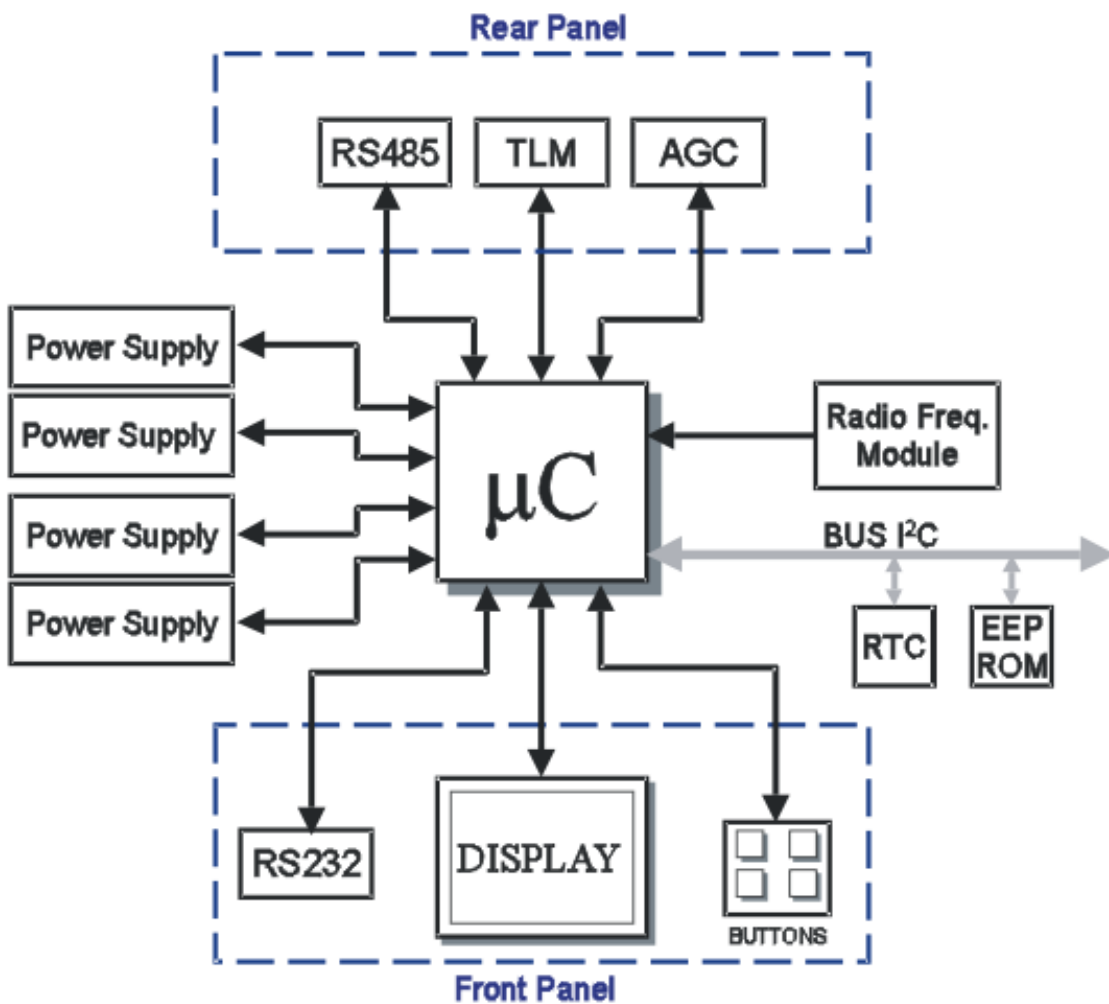

Figure 1: Simplified block diagram of the control and display board

It can be seen that the micro-controller is the heart of the control system, to which the various peripherals (power supply, serial ports, telemeasure socket, AGC port, RF amplifier module, ROM, clock, display and keys) are interfaced.

- Power Supply

The board is powered with a continuous +24V voltage applied on the J14 connector. From that the +5V voltage, powering the most of the chips (micro-controller, operational amplifiers, display, etc.) is derived by means of a switching converter (see IC19). A +12Vdc voltage is obtained from it as well, by means of a linear conversion provided by the integrated circuit IC8. From this, a -12Vdc voltage is obtained by means of the integrated circuit IC5. The -12V voltage is used to adjust the contrast of the display.

- Connectors

On the board SCH0223AR1 there are several connectors used as interfaces for the peripherals of the apparatus and the ports for external communication.

POWER SUPPLY

The connectors J1, J6, J8 e J12 are used to connect the power supply powering the RF modules. The number of power supply used changes depending on the amplifier, up to eight power supply. They are connected in the order shown in Table 1 below. Remaining connectors, if any, are left unconnected.

CONNECTOR	POWER SUPPLY N°
J1	1 - 2
J6	3 - 4
J8	5 - 6
J12	7 - 8

Table 1: Interface connectors for the power supply

Through this connection, each power supply provides the level of voltage and current acquired by the micro-controller by means of an internal ADC. Besides the connectors allow the control board to turn on or off the individual power supply (for instance when an alarm occurs).

RF AMPLIFICATION

The J3 connector interfaces the control board with the RF amplification section. Through this connector the micro-controller acquires the forward and reflected powers, unbalancing (if any), and temperature of the critic amplification area. It also allows to inhibit the transistors in case of reflected power alarm, by means of a totally hardware, thus extremely fast protection.

Depending on the apparatus, this connector may also allow to enable or disable the cooling fans of the critic area.

RS485

The J11 connector (10 pin socket) is directly wired to a DB9 female connector placed on the rear panel of the apparatus. This communication bus allows to connect the amplifier to the control (Amplifier Control) module of a high-power transmitter composed by several individual amplifiers. In this case, each amplifier and the Amplifier Control are connected to the same 4-wires RS485 bus and each of them has a unique address (which can be set by means of the keys and the display) for correct communication.

In case of single (stand-alone) amplifier, the RS485 connector can be used to interface to the Remote Control Unit (RCU) made by Elettronika S.r.l. This unit allows to monitor and control the remote transmitter from any site provided with PSTN or GSM¹ phone connection.

Table 2 shows the wiring between the J11 connector on the board and the DB9 female connector on the rear panel, along with the description of the lines.

PIN N° ON DB9	PIN N° ON J11	DESCRIPTION
1	1	Not used
2	3	Rx-
3	5	Rx+
4	7	+5V
5	9	GND
6	2	Not used
7	4	Tx-
8	6	Tx+
9	8	Not used

Table 2: Description of the RS485 connector

¹ For more details about the control system contact the distributor or the manufacturer.

TELEMEASURES

The J9 telemeasure connector (10 pins socket) is directly wired on a DB9 female connector placed on the rear panel. There are input and output digital lines (TTL level) and analog output lines on this connector, which are used to monitor and control the amplifier by means of a general-purpose remote control system.

The correspondence between the pins of the J9 connector on the board and the DB9 female connector on the rear panel, as well as the meaning of the various lines, is shown in table 3 below (the directions are in respect to the micro-controller on the board).

PIN N° ON DB9	PIN N° ON J9	TYPE	DIRECTION	DESCRIPTION
1	1	Analog	Output	Forward power (*)
2	3	Analog	Output	Reflected power (*)
3	5	Analog	Output	Temperature
4	7	Digital	Input	Interlock: 0V = Interlock Alarm 5V = Normal
5	9	-	-	Ground
6-7	2-4	Digital	Output	Free Contact (closed when amplifier is in alarm)
8	6	Digital	Input	Turning-on control (normally high, active when low)
9	8	Digital	Input	Turning-off control (normally high, active when low)

(*) You can select by means of two jumpers on the board (JP1 and JP2) RMS or peak power. If there are two jumpers on pins 1 and 2 of JP1 and JP2 connectors, RMS power is selected. Otherwise, if there are two jumpers on pins 2 and 3 of the same connectors, peak power is selected.

Table 3: Description of the telemeasures connector

The input stage of the digital pins has an internal pull-up towards the 5V power supply voltage. To use these lines it only takes setting a switch to close to earth. When closed, the relevant control (turning on or off) is enabled and the switch may be open again (impulse controls).

The interlock pin may be used as protection so that the amplifier is switched off when the digital input level is low. It is possible to use several serially connected switches to make an interlock chain. Usually all switches are closed and the interlock level is low, thus the amplifier is on. If even only one of the switches is open, the

level of the interlock signal becomes high (this line has a pull-up towards the +5V power supply voltage as well) and the interlock protection activates switching off the amplifier. Note that in case the interlock protection is not used, the pin 4 of the DB9 telemeasure connector and the earth pin (pin 5) must be short circuited. Otherwise it is possible to disable the monitoring of the interlock chain from menu (see user manual). Figure 2 shows a typical usage for the digital input signals to turn on and off the amplifier and for the interlock alarm.

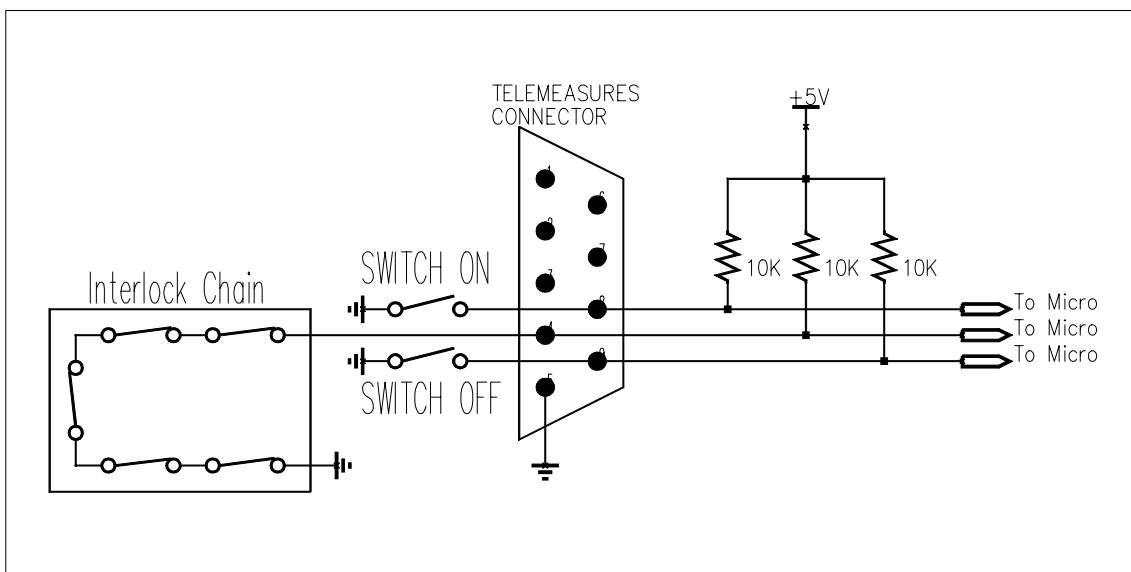

Figure 2: Usage of the digital input signals of the telemeasures connector

AGC/EXCITER

The connector called J10, as the telemeasures connector and the RS485 bus, is wired to a DB9 female connector placed on the rear panel of the amplifier. This connector allow the implementation of an automatic gain control between an exciter and the amplifier. A voltage signal related to the forward output power supplied by the amplifier is provided through two pins of the AGC connector. Connecting one of these to the relevant input pin of the exciter, this can pursuit a given voltage level, so that the output power is always constant. In order to avoid that, in case of an alarm decreasing the forward power, the exciter increases its output level due to the AGC, thus damaging the amplification stages, the connector is provided with two digital output lines called AGC Alarm. Under alarm conditions, this lines are brought by the micro-controller at a low level, so that the exciter can stop the AGC.

Table 4 shows the connection between the J10 connector on the board and the DB9 connector on the rear panel, along with the description of each pin (the direction of the pin is referred to the position of the micro-controller on the board).

PIN N° ON DB9	PIN N° ON J10	TYPE	DIRECTION	DESCRIPTION
1	1	-	-	Ground
2	3	Digital	Output	AGC Alarm 0V = Alarm 5V = Normal
3	5	Digital	Output	AGC Alarm 0V = Alarm 5V = Normal
4	7	-	-	Not used
5	9	-	-	Not used
6	2	-	-	Not used
7	4	-	-	Not used
8	6	Analog	Output	Forward power
9	8	Analog	Output	Forward power

Table 4: Description of the AGC connector

RS232

The DB9 female connector on the front panel is an external communication RS232 serial port, through which a PC can be connected directly to the amplifier in order to perform operations such as the remote control (by means of an adequate software²) and the update of the microcontroller firmware.

The used communication protocol is asynchronous, at a 19200bps speed, 1 start bit, 8 data bits, 1 stop bit, no parity. No hardware flow control is used. The connector is DCE type and the pin used are shown in Table 5.

PIN N° ON DB9	1	2	3	4	5	6	7	8	9
DESCRIPTION	-	TxD	RxD	-	GND	-	-	-	-

Table 5: Description of the RS232 connector

MISCELLANEOUS

The J2 (called AUX), J4, J5 and J17 connectors are not used and are there only for future updates. The SW1 dip-switches are partially used for the configuration of the correct mode for the micro-controller. The other switches are not used. It is important that the position of the dip-switches is left unchanged, because changing it may set a wrong mode for the micro-controller, affecting the work of the whole amplifier.

² For more information about this application contact the distributor of the manufacturer.

FIRMWARE UPDATE

The microcontroller is provided with a built-in Flash memory containing the firmware. The firmware can be updated with a later version without removing the apparatus from the rack and/or replacing the chip.

To upgrade it, connect a PC to the RS232 socket on the front panel of the apparatus by means of a cable DB9 male - DB9 female (pin-to-pin).

Launch on the PC the EKAFlash application, select the serial port in use on the PC, choose the update file by pressing the “...” key and click on Download button.

Eventually, turn off the amplifier from the main switch and then turn it on again. The upgrade of the firmware begins on the EKAFlash window. Figure 3 shows this window while a firmware is being updated.

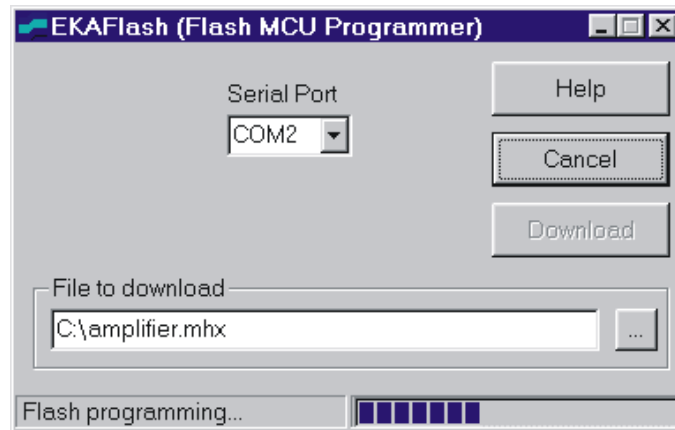
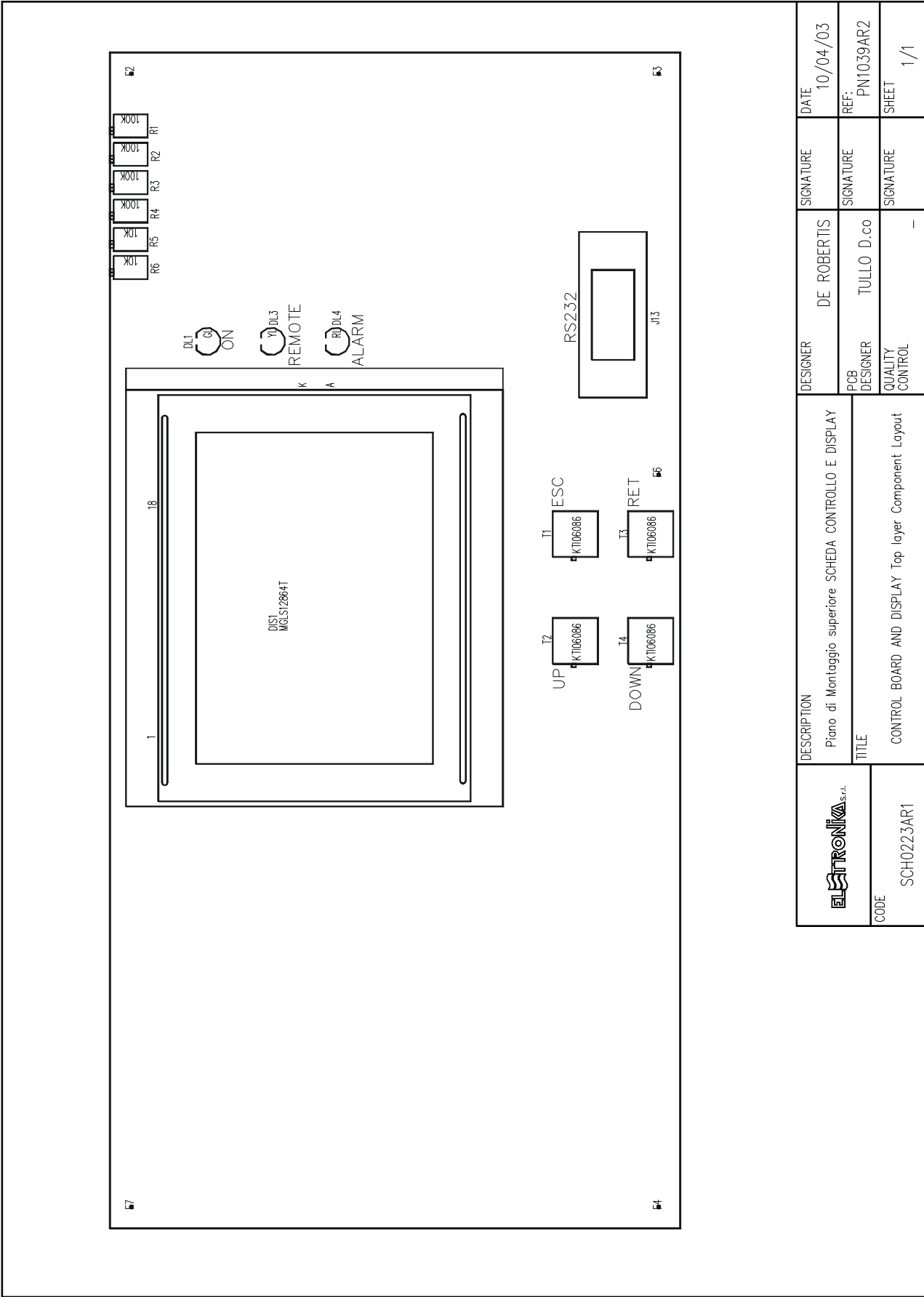

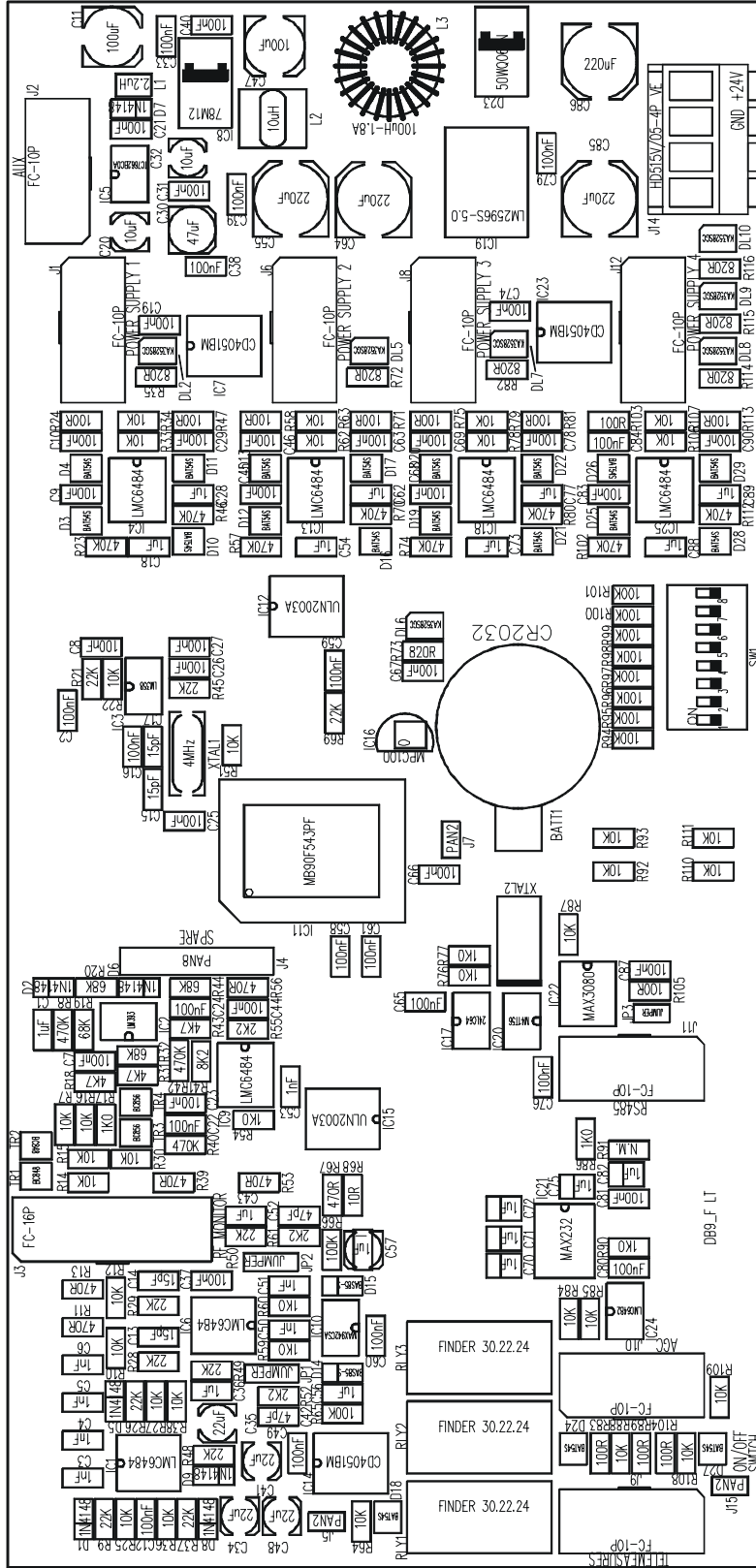



Figure 3: The EKAFlash window while updating a firmware



 CODE SCH0223AR1	DESCRIPTION	DESIGNER	SIGNATURE	DATE
	Piano di Montaggio superiore SCHEDA CONTROLLO E DISPLAY TITLE CONTROL BOARD AND DISPLAY Top layer Component Layout	DE ROBERTIS	DE ROBERTIS	10/04/03
		PCB DESIGNER	SIGNATURE	REF:
		QUALITY CONTROL	SIGNATURE	PN1039AR2
			SIGNATURE	SHEET
				1/1



	DESCRIPTION	DESIGNER	SIGNATURE	DATE
	Piano di Montaggio inferiore SCHEDA CONTROLLO E DISPLAY TITLE CONTROL BOARD AND DISPLAY Bot layer Component Layout	DE ROBERTIS PCB DESIGNER QUALITY CONTROL	DE ROBERTIS TULLO D.co -	SIGNATURE SIGNATURE SIGNATURE
CODE	SCH023AR1			

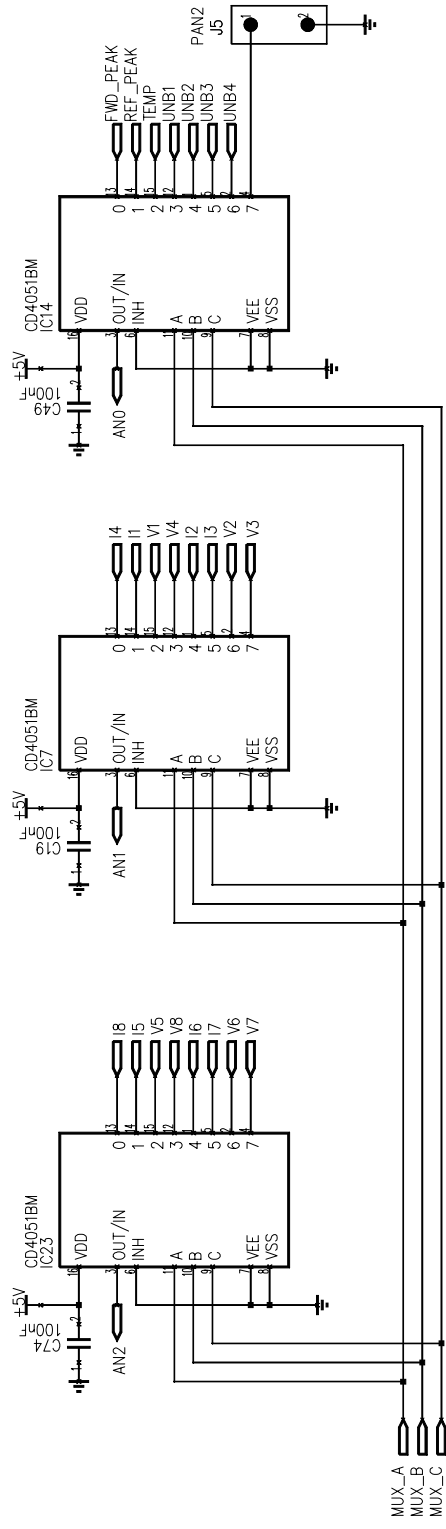

	DESCRIPTION	MULTIPLEXER	DESIGNER	R. de Robertis	SIGNATURE	DATE	10/04/2003
	TITLE	PBOX2003 AMPLIFIER CONTROL BOARD	PCB DESIGNER	Tullio D.co	SIGNATURE	REF:	PN1039AR2
CODE	SCH0223AR1			SHEET	1 of 6		

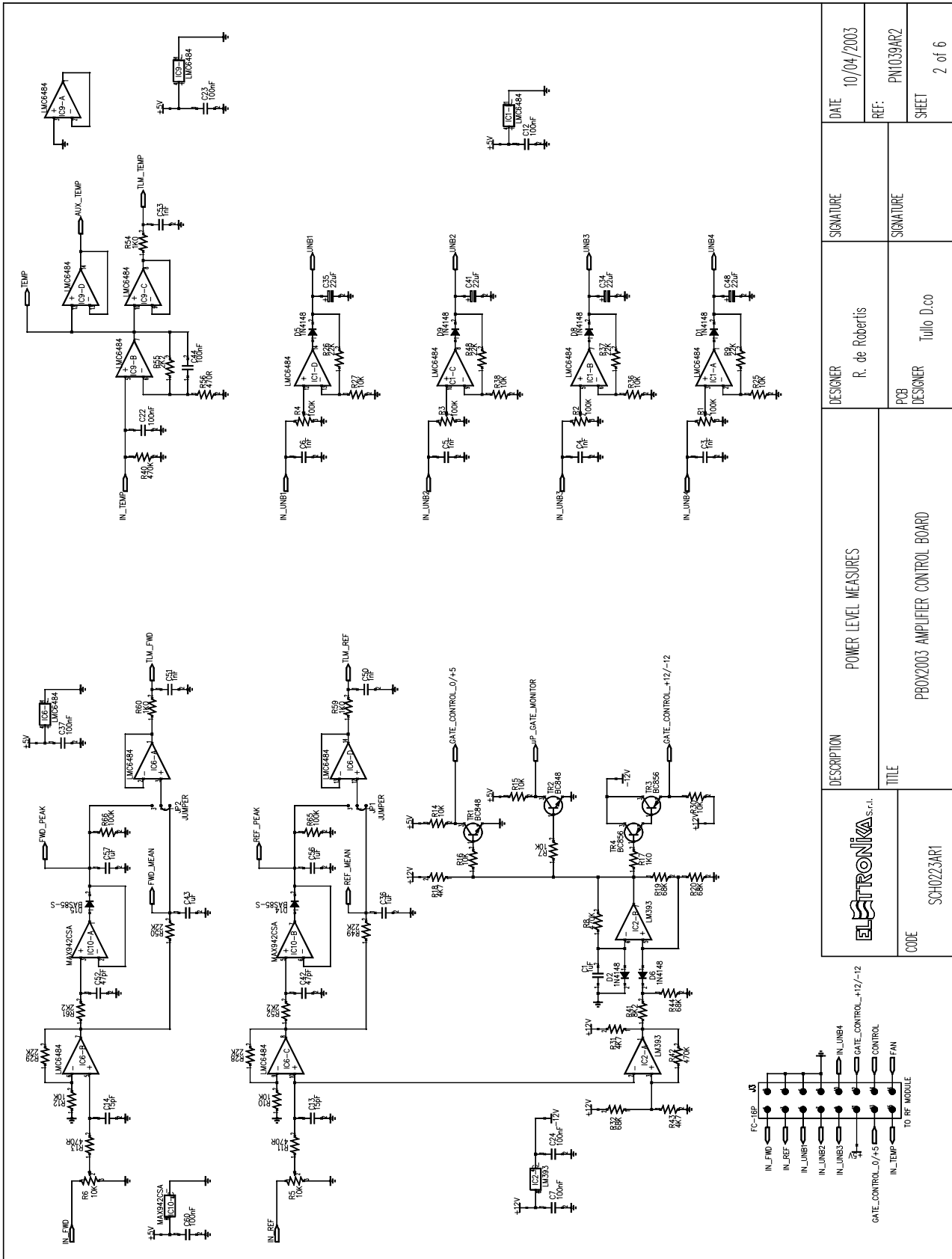

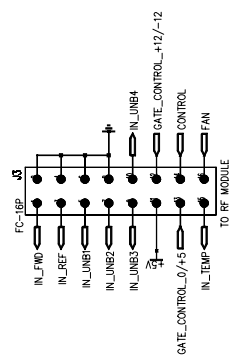

ELSTRONIKA S.r.l.	DESCRIPTION	POWER LEVEL MEASURES	
	TITLE	PBOX2003 AMPLIFIER CONTROL BOARD	
CODE	SC40223A1	DESIGNER	R. de Robertis
		SIGNATURE	
		PCB DESIGNER	Tullio D.co
		SIGNATURE	
		DATE	10/04/2003
		REF:	PN1039AR2
		SHEET	2 of 6

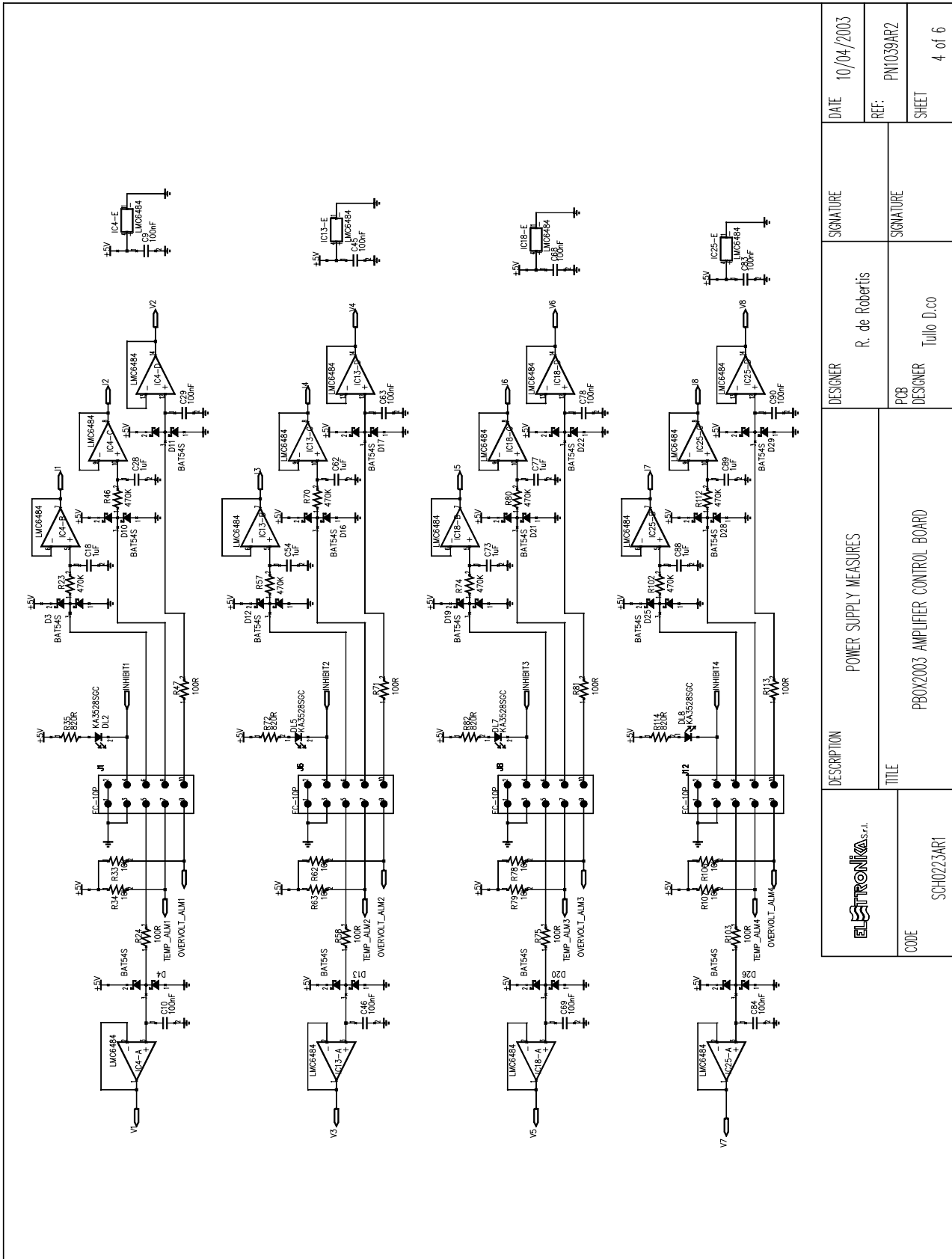

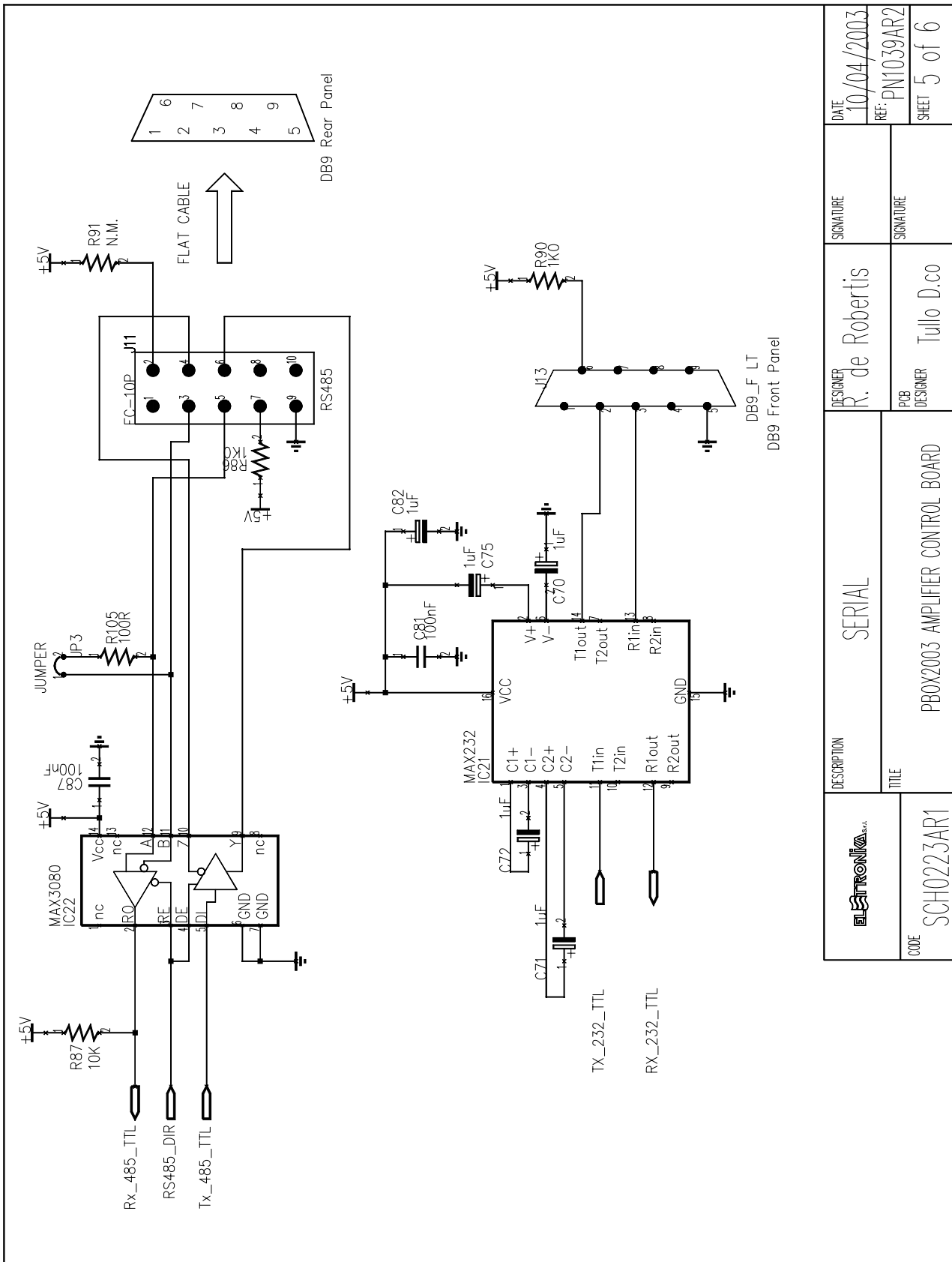

DESCRIPTION	POWER SUPPLY MEASURES		DESIGNER	R. de Robertis	SIGNATURE		DATE	10/04/2003
	TITLE		PCB DESIGNER		SIGNATURE		REF:	PNT039AR2
CODE	SCH0223AR1		TITLE		SIGNATURE		SHEET	4 of 6
		PBOX2003 AMPLIFIER CONTROL BOARD		DESIGNER		SIGNATURE		
				PCB DESIGNER		SIGNATURE		



 CODE SCH0223AR1	DESCRIPTION	SERIAL		DESIGNER	R. de Robertis	SIGNATURE		DATE	10/04/2003
	TITLE	PBOX2003 AMPLIFIER CONTROL BOARD		PCB DESIGNER	Tullo D.co	SIGNATURE		REF:	PN1039AR2
								SHEET	5 of 6

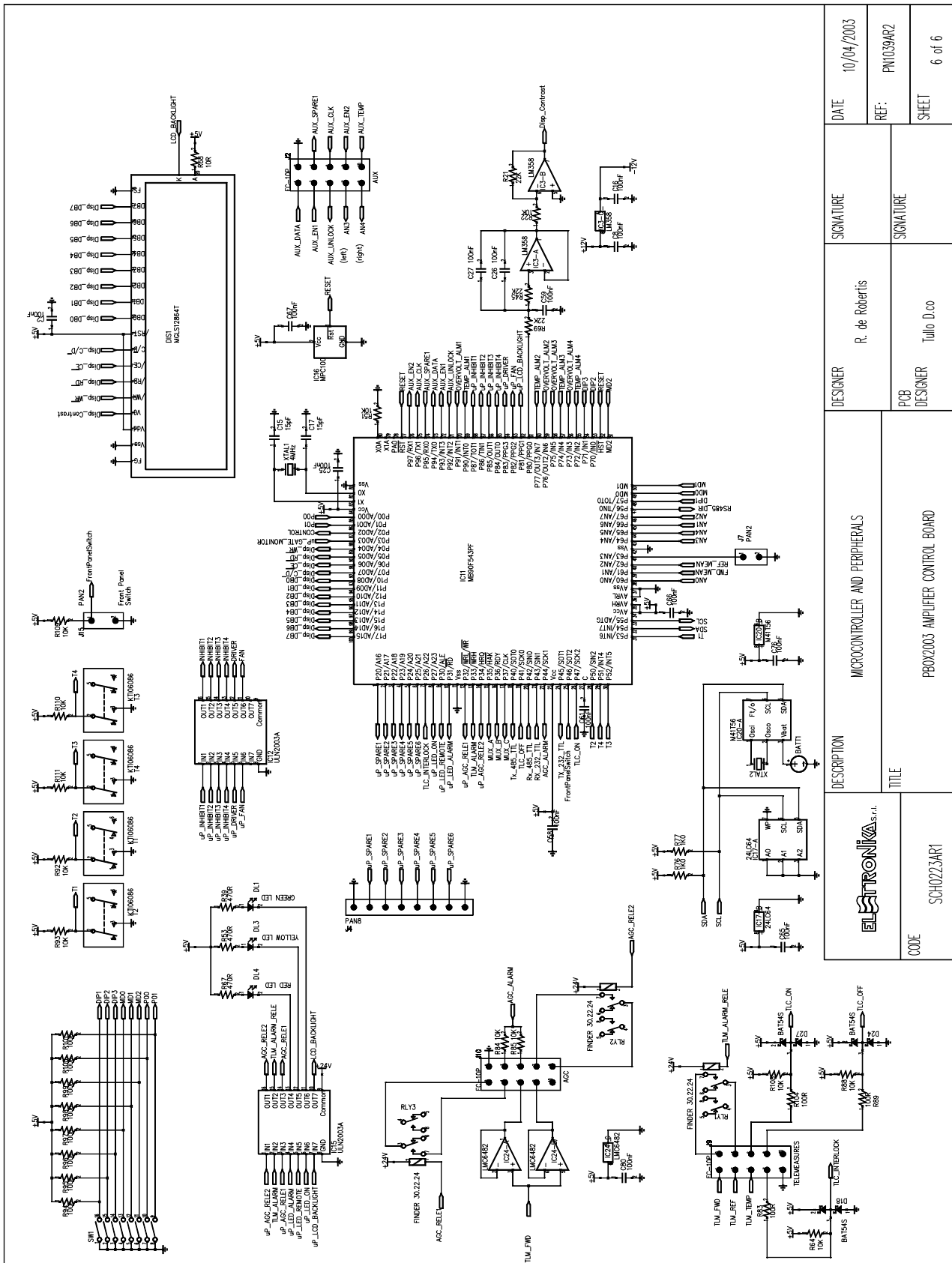

COMPONENT LIST SCH0223AR1

Part Name/Number	Description	Qty.	Comps.	Page 1/2
BATT BH001RB 3093_90	03093 03090 BATTERY HOLDER	1	BATT1	
CC 100nF-S 01065C	01065C Y5V 1206 COND	46	C2, C7-10, C12, C16, C19, C21-27 C29, C31, C33, C37-40, C44-46, C49, C58-61, C63, C65-69, C74, C76, C78-81, C83-84, C87, C90	
CC 15pF-S 01088	01088 SMD 1206 COND	4	C13-15, C17	
CC 1nF-S 01096	01096 SMD 1206 COND	7	C3-6, C50-51, C53	
CC 1uF100V-S 01760A	01760A Y5V 1206 COND	13	C1, C18, C28, C36, C43, C54, C56-57, C62, C73, C77, C88-89	
CC 47pF-S 01100	01100 SMD 1206 COND	2	C42, C52	
CE 100uF25V-S 01793B	01793B ELETTR SMD COND	2	C11, C47	
CE 10uF35V-S 01778A	01778A ELETTR SMD COND	2	C20, C32	
CE 1uF35V-S 01613A	01613A TANTALIUM ELETTR SMD CO	5	C70-72, C75, C82	
CE 220uF50V LOW ESR	1799A ELETTR SMD COND LOW ESR	4	C55, C64, C85-86	
CE 22uF16V-S	01780A ELETTR SMD COND	4	C34-35, C41, C48	
CE 47uF35V-S 01790A	01790A ELETTR SMD COND	1	C30	
D 1N4148-S 03002	03002 SMD DIODE	7	D1-2, D5-9	
D 50WQ06FN	03019A SMD DIODE SCHOTTKY 5,5A	1	D23	
D BAS85-S	03024 SMD DIODE SCHOTTKY	2	D14-15	
D BAT54S	03199 SMD SCHOTTKY DIODE A-K T	19	D3-4, D10-13, D16-22, D24-29	
DIS MGLS12864T	03083A 128x64 DOT (BLUE-LED WH	1	DIS1	
DL KA-3528SGC 03057	03057 GREEN SMD LED DIODE	7	DL2, DL5-10	
DL LEDG5 03060	03060 GREEN LED DIODE 5mm	1	DL1	
DL LEDR5 03061	03061 RED LED DIODE 5mm	1	DL4	
DL LEDY5 03054B	03054B YELLOW LED DIODE 5mm	1	DL3	
IC 24LC64 04815	04815 SMD INTEG CIRCUIT	1	IC17	
IC 78M12 4307B	04307B SMD VOLTAGE REGULATOR	1	IC8	
IC CD4051BM-S	04615 SMD INTEG CIRCUIT	3	IC7, IC14, IC23	
IC LM2596S-5.0	04580 SMD INTEG CIRCUIT	1	IC19	
IC LM358M-S 04660	04660 SMD INTEG CIRCUIT	1	IC3	
IC LM393-S 04639	04639 SMD INTEG CIRCUIT	1	IC2	
IC LMC6482-S	04632 SMD INTEG CIRCUIT	1	IC24	
IC LMC6484-S	04634 SMD INTEG CIRCUIT	7	IC1, IC4, IC6, IC9, IC13, IC18, IC25	
IC M41T56 04611	04611 SMD INTEG CIRCUIT	1	IC20	
IC MAX232-S 04804B	04804B SMD INTEG CIRCUIT	1	IC21	
IC MAX3080-S 04770	04770 SMD INTEG CIRCUIT	1	IC22	
IC MAX942CSA-S	04572 SMD INTEG CIRCUIT	1	IC10	
IC MB90F543PF	04596 SMD INTEG CIRCUIT	1	IC11	
IC MPC100-450DI-TO	04608 INTEG CIRCUIT	1	IC16	
IC TC7662BCOA 04758A	04758A SMD INTEG CIRCUIT	1	IC5	
IC ULN2003A 4870	04870 SMD INTEG CIRCUIT	2	IC12, IC15	
IND 2u2H-S 05020A	05020A INDUCTOR	1	L1	

Part Name/Number	Description	Qty.	Comps.	Page 2/2
IND MS85 10uH-S	04948 INDUCTOR 2,7 A	1	L2	
IND T100uH-1.8A 4958	04958 TOROIDAL-STORAGE CHOKES	1	L3	
J CON HD515V/05-4PVE	02881 + 02882 PANDUIT PCB CONN	1	J14	
J DB9_F-0° LT	02794 PCB CONNECTOR DB9 LONG T	1	J13	
J FC-10P 02697-02699	02697+02699 PCB CONNECTOR POL	8	J1-2, J6, J8-12	
J FC-16P 02701-02700	02701+02700 PCB CONNECTOR POL	1	J3	
J PAN2 02739-40-41	02739+02740+02741 PCB CONNECTO	3	J5, J7, J15	
J PAN8 02716	02716 PCB CONNECTOR	1	J4	
JU JUMP2 02739-02742	02739+02742 MASCHIO PAN2	1	JP3	
JU JUMP3 02707-02742	02707+02742 MASCHIO PAN3	2	JP1-2	
R 100K-1%-S 00065B	00065B RES 1/4W 1% SMD 1206	10	R65-66, R94-101	
R 100R-1%-S 00029D	00029D RES 1/4W 1% SMD 1206	12	R24, R47, R58, R71, R75, R81, R83, R89, R103-105, R113	
R 10K-1%-S 00053B	00053B RES 1/4W 1% SMD 1206	32	R7, R10, R12, R14-16, R22, R25, R27, R30, R33-34, R36, R38, R51, R62-64, R78-79, R84-85, R87-88, R92-93, R106-111	
R 10R-S 00017A	00017A RES 1/4W 5% SMD 1206	1	R68	
R 1206 NOT MOUNTED	NOT MOUNTED RES 1/4W 5% SMD 12	1	R91	
R 1K0-1%-S 00041B	00041B RES 1/4W 1% SMD 1206	8	R17, R54, R59-60, R76-77, R86, R90	
R 22K-1%-S 00057B	00057B RES 1/4W 1% SMD 1206	11	R9, R21, R26, R28-29, R37, R45, R48-50, R69	
R 2K2-1%-S 00045B	00045B RES 1/4W 1% SMD 1206	3	R52, R55, R61	
R 470K-S 00073A	00073A RES 1/4W 5% SMD 1206	11	R8, R23, R40, R42, R46, R57, R70, R74, R80, R102, R112	
R 470R-1%-S 00037B	00037B RES 1/4W 1% SMD 1206	6	R11, R13, R39, R53, R56, R67	
R 4K7-1%-S 00049B	00049B RES 1/4W 1% SMD 1206	3	R18, R31, R43	
R 68K-1%-S 00063B	00063B RES 1/4W 1% SMD 1206	4	R19-20, R32, R44	
R 820R-S 00040A	00040A RES 1/4W 5% SMD 1206	7	R35, R72-73, R82, R114-116	
R 8K2-1%-S 00052B	00052B RES 1/4W 1% SMD 1206	1	R41	
RL 30.22.24 07569	07569 RELE	3	RLY1-3	
RV 100K-3266X	00814 VARIABLE RESISTOR	4	R1-4	
RV 10K-3266X 00807	00807 VARIABLE RESISTOR	2	R5-6	
SW SWITCH-8DIP	07530A PCB DIP SWITCH SMD	1	SW1	
T 06086 N 7630 7632	7630 7632 KTI06086 PULSANTE 2	4	T1-4	
TR BC848 03457	03457 NPN SMD TRANSISTOR	2	TR1-2	
TR BC856 03455	03455 PNP SMD TRANSISTOR	2	TR3-4	
XTAL 32.768k-S 05146	05146 QUARTZ	1	XTAL2	
XTAL 4MHz-S 05101A	05101A QUARTZ	1	XTAL1	

Component layout SCH0288AR1

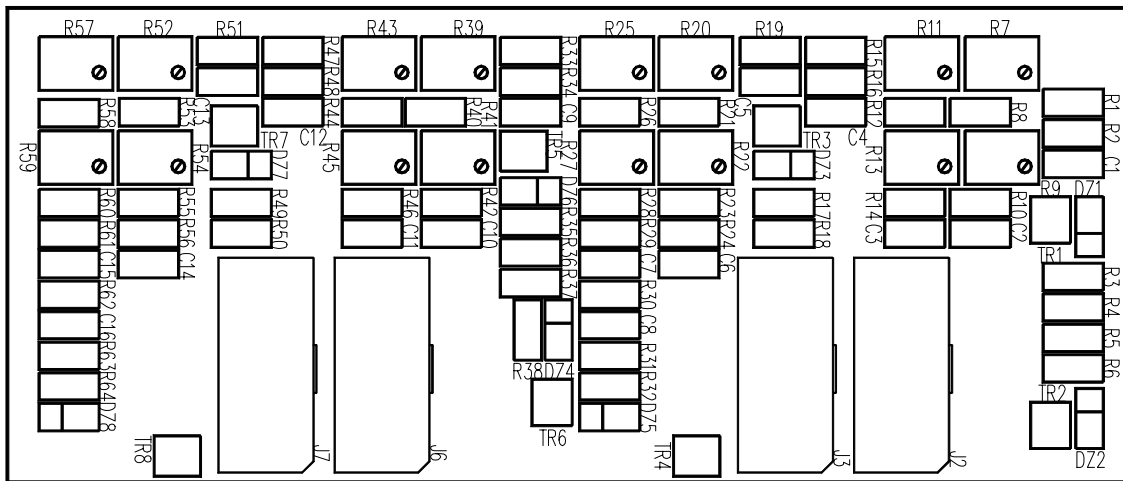

COMPONENT LIST SCH0288AR1

Part Name/Number	Description	Qty.	Comps.
CC 1nF-S 01096	01096 SMD 1206 COND	16	C1-16
DZ 5V1-S 03128	03128 SMD ZENER DIODE	8	DZ1-8
J FC-10P 02697-02699	02697+02699 PCB CONNECTOR POL	4	J2-3, J6-7
J FC-10P PCB FEMALE	02706 PCB FEMALE CONNECTOR POL	4	J1, J4-5, J8
R 0R0-S 00001	00001 RES 1/4W 5% SMD 1206	16	R1, R8, R12, R15, R21, R23, R26, R28, R33, R40, R44, R47, R53, R55, R58, R60
R 10K-S 00053A	00053A RES 1/4W 5% SMD 1206	16	R3-6, R17-18, R31-32, R35-38, R49-50, R63-64
R 1206 NOT MOUNTED	NOT MOUNTED RES 1/4W 5% SMD 12	16	R2, R10, R14, R16, R19, R24, R29, R30, R34, R42, R46, R48, R51, R56, R61-62
RV 3266W NOT MOUNT	NOT MOUNTED VARIABLE RESISTOR	16	R7, R9, R11, R13, R20, R22, R25, R27, R39, R41, R43, R45, R52, R54, R57, R59
TR BC847 03456	03456 NPN SMD TRANSISTOR	8	TR1-8

Component layout SCH0265AR0

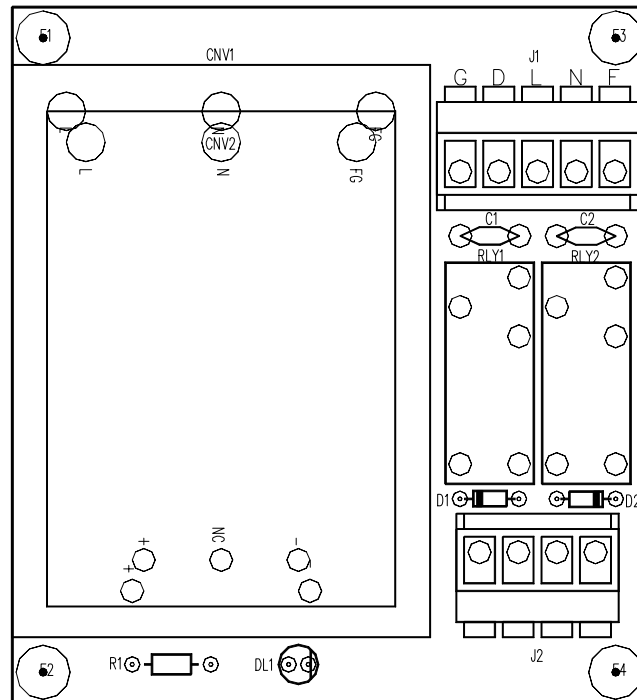

COMPONENT LIST SCH0265AR0

Part Name/Number	Description	Qty.	Comps.
CC 2nF2 2kV 01045A	01045A CERAMIC COND	2	C1-2
CNV AC-DC ATC-12S	E0037 AC DC CONVERTER	1	CNV1
D 1N4148 03001	03001 DIODE	2	D1-2
DL LEDG3 03053	03053 GREEN LED DIODE 3mm	1	DL1
J CON HD515V/05-4PVE	02881 + 02882 PANDUIT PCB CONN	1	J2
J CON HD515V/05-5PVE	PANDUIT PCB CO	1	J1
R 2K7 0046	0046 RES 1/4W 5%	1	R1
RL 40.31.24	7567C RELE	2	RLY1-2

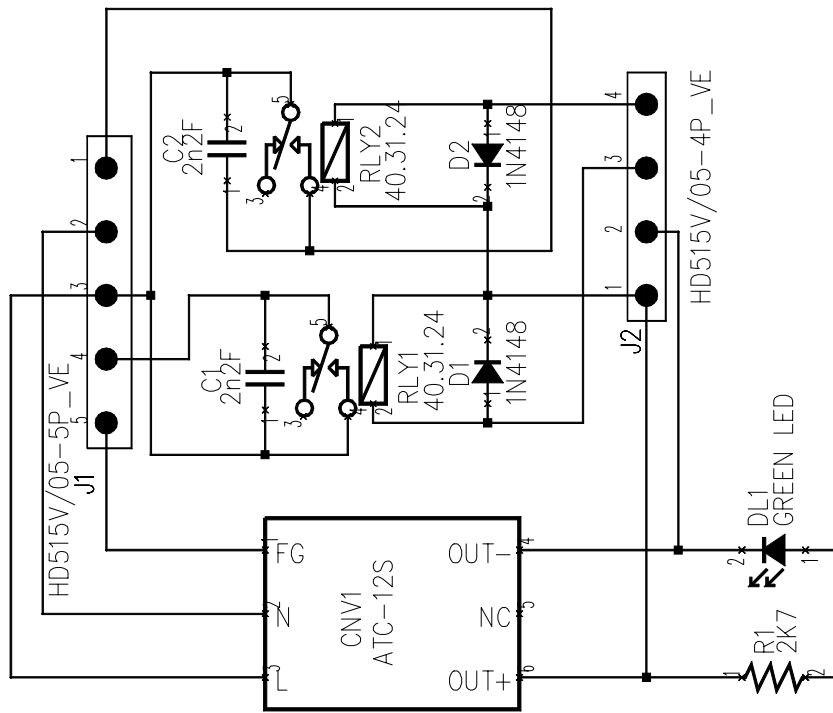

 CODE: SCH0265AR0	DESCRIPTION	ELECTRICAL DIAGRAM		DESIGNER	DI MODUGNO	SIGNATURE	DATE	17/11/03	
	TITLE	MAINS DISTRIBUTION BOARD		PCB DESIGNER	TULLO D.CO	SIGNATURE	REF.	PNT11ART1.SDM	
							SHEET	1 OF 1	

SPECIFICATION

MODEL	SP-500-27 (E0012 Code)	SP-500-48 (E0013 Code)
DC Output Voltage	27Vdc	48Vdc
Output Rated Current	18A	10A
Output Current Range	0-18A	0-10A
Ripple & Noise (p-p)	200mVp-p	240mVp-p
DC Output Power	486W	480W
Efficiency	87%	87%
DC Voltage Adj.	24-30V	41-56V
Over V. Protection	31V-36.5V	57.6V-67.2V
Input Voltage Range	88-264Vac	
Input Frequency	47-63Hz	
Power Factor	0.95/100-240Vac	
Overload Protection	105%-135%	
	Type: Foldback current limiting	
	Recovery: Auto	
Over Temp. Protection	> =70°C Output Shutdown	
Fan Control	Temp. > =60°C Fan On	
	< =50°C Fan Off	
Working Temp., Humidity	-10°C/+50°C, 20%-90% RH	
Dimension	185x120x93	
Weight	1.8Kg.	

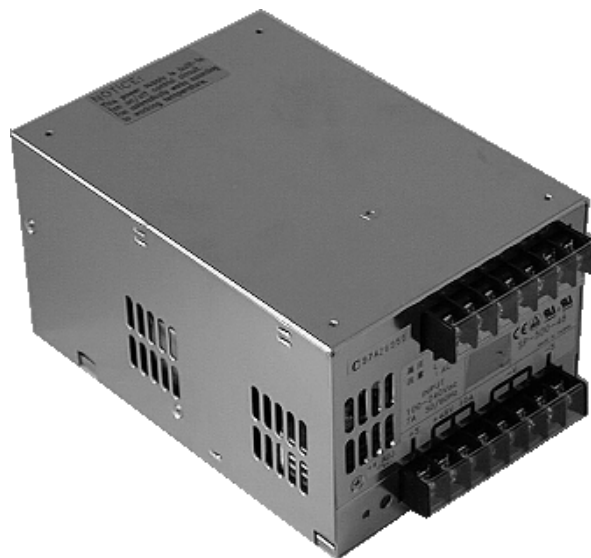

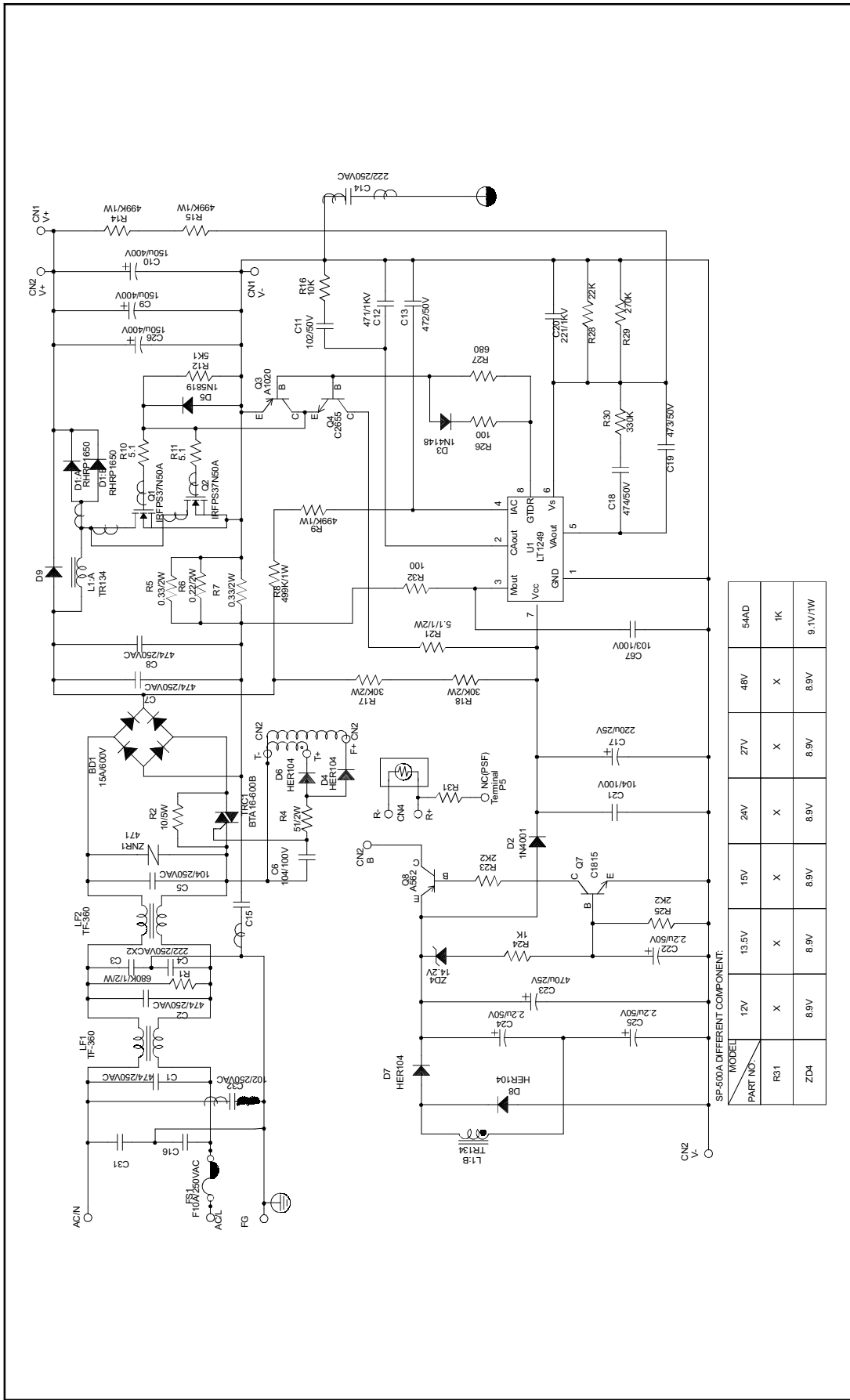

SP-500A DIFFERENT COMPONENT:

MODEL	12V	13.5V	15V	24V	27V	48V	54AD
PART NO.							
RS1	X	X	X	X	X	X	1K
ZD4							9.1V/1W

	DESCRIPTION	SP500-27-DI Switching Power Supply	
	TITLE	Electric Diagram	
CODE	E0012	DESIGNER	---
		P.CB DESIGNER	---
		QUALITY CONTROL	---
		SIGNATURE	---
		SIGNATURE	---
		SIGNATURE	---
		DATE	28/10/2004
		REF	E0012_Component_Import.dwg
		SHEET	2/2

UHF BANDPASS FILTER
600W, 3 Sections + 2 Notches

Code 06673



FEATURES

- UHF 500W analog TV output filter
- 3 bandpass resonators and 2 notches
- Foreshorten in-line combine structure
- Iris couplings with fine bandwidth regulation
- Phase regulation between bandpass and notches
- Low loss (Typ. 0.42dB @ Ch. 69 G)
- Compact and lightweight

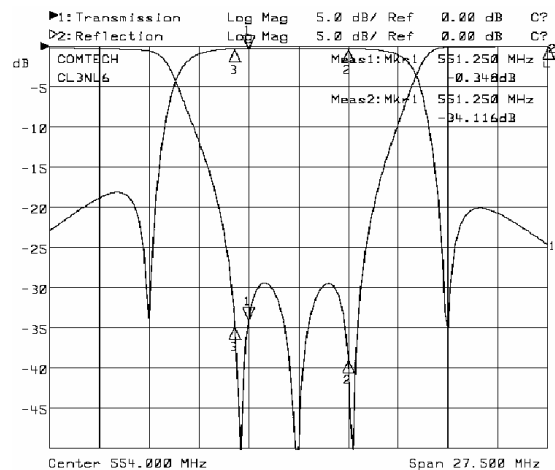
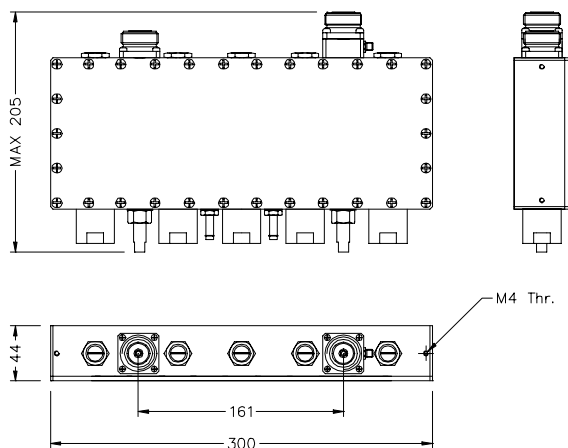

SPECIFICATIONS (Values referred to B Standard)

Frequency Range	470 - 862MHz
Max Input Power	500W Analog TV
Insertion Loss	< 0.50dB @ V.C. Ch. 69 < 0.45dB @ V.C. Ch. 21
Return Loss	> 28dB
Group Delay Variation	< 25nS
Bandwidth	6 to 8MHz

Selectivity	> 32dB @ V.C. -5.5 / +11MHz > 22dB @ V.C. -11 / +16.5MHz
Temperature Stability	< 17kHz / K
Connectors	7/16 Female
Weight (Approx)	2.7kg
Operating temperature	-10 to +50°C

AVAILABLE OPTIONS

A SMA Output Monitor Probe

B N Female Connector

TECHNICAL DESCRIPTION

The output filter mod. 06673 is made up of a 3 resonators bandpass filter and two notches. It can be tuned on all the channels of the UHF TV band (470 - 862MHz) and according to all worldwide standards (4.5 - 6.5MHz intercarrier). The bandpass section is composed by the three middle resonators, while the two resonators apart are the notches. The filter is symmetrical; therefore, the choice of the lowest and the highest notch is indifferent.

The bandwidth regulation is accomplished by varying the insertion of the two Post Rods, which are located between the bandpass resonators; the insertion of the Post Rods increases the bandwidth. In order to execute this regulation it is necessary to loosen every lock nut by means of a n. 12 pipe key.

The input/output couplings are regulated by means of the two shafts (Coupling Stub) opposite to each connector. The regulation is carried out with n. 8 flat key, considering that when the operating flattenings are parallel to the longer side of the filter the coupling is maximum, otherwise if orthogonal the coupling is minimum.

The frequency response symmetry is determined by the insertion of the previously mentioned shafts; these shafts can be set after loosening the relevant clamps with a pipe wrench n. 16. Once locked, these clamps set out also the twist friction of the couplings.

TUNING INSTRUCTIONS

The advised tuning sequence is the following:

1. Set the instrument state as follows:

- C.F. = (V.C. + S.C.) / 2
- SPAN = INTERCARRIER * 5 (E.G. 27,5MHz std. B/G)
- TRANSMISSION SCALE = 5dB/div.
- REFLECTION SCALE = 5dB/div.

2. Preset the Coupling Stubs and the bandwidth (Posts), measuring them from the extremity to the filter's body, according to the following table:

C.F. (MHz)	COUPLING STUBS (mm)	POSTS (mm)			
		B, G Standards	K, K1 Standards	M, N Standards	I Standard
474	27	27	16	48	20
666	48	32	28	41	30
858	62	22	18	28	20

-
3. Tune the bandpass section on the required channel, and match input and output until a correct response is achieved. During this step, the tunings of the two notches shall be kept well far from the bandpass response. Regulate the bandwidth at -24dB to the ends of span (E. g. std. G: BW (-24dB) = 27,5MHz). The input/output couplings may influence the external resonators; therefore, it will be necessary to repeatedly fix the formers after the latters in small steps. The frequency response must be centered, with the same attenuation values at both sides of the screen.
 4. Tune the two notches to P.V. - INTERCARRIER and P.A. + INTERCARRIER frequencies. This will vary the response and matching. Adjust the response acting on the bandpass tunings.
 5. Improve the calibration alternatively acting on two sides of the filter according to this sequence:
 - regulate the couplings;
 - re-tune notches if they have to be moved;
 - re-tune the bandpass resonatoes.
 6. Execute the sequence in small steps aiming to improve the matching. Check the response symmetry, and correct it if needed according to the following criterion: if the lowest notch is much more emphasized than the highest one it is necessary to insert the Coupling Stubs, otherwise if the highest notch is more emphasized than the lowest one it is necessary to extract the Coupling Stubs.
 7. At the end of the tuning process, lock the trim points (Posts and Coupling Stubs) and assemble the coupling protection caps on the filter.

SPECIFICATION OVER THE UHF BAND

MEASURE	VALUE
Insertion Loss @ V.C.	< 0.50dB @ V.C. Ch 69 G (Typ. 0.38) < 0.45dB @ V.C. Ch 21 G (Typ. 0.33)
Return Loss (from V.C.-0.75 to S.C. +0.25)	> 28dB
Attenuation @ V.C. - INTERCARRIER	> 32dB
Attenuation @ V.C. + INTERCARRIER	> 24dB

SAMPLE FREQUENCY RESPONSE DIAGRAM

