

## ***Section 1 - Information***

*Contents:*

*1.1 Description*

*1.2 Technical characteristics*

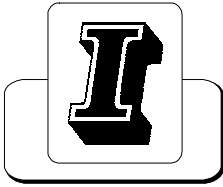

---

# AUTV/1500LD

## LDMOS - UHF TV AMPLIFIER

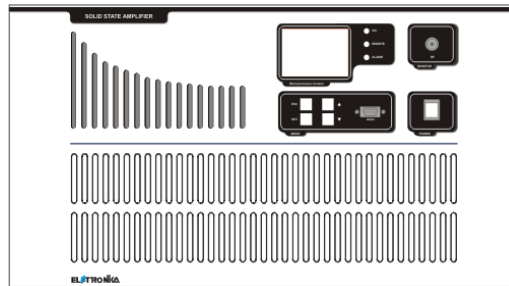

### 1.1 DESCRIPTION

The AUTV/1500LD is an amplifier operating into Band IV-V for common amplification process of the Vision and Sound carriers.

The amplifier has been designed to offer to the customer high performances, high reliability and greater simplicity in his operation and maintenance procedures.

The amplifiers modules employ all solid state LDMOS technology in order to obtain high gain, wide-band performances, very good linearity, reliability and high efficiency.

The equipment design allows the soft degradation (RF power loss) for several transistor faulty: in fact the output combiner uses RF power resistors for unbalancing power dissipation. The unit is enclosed in a cabinet for 19"- 6U rackmounting.

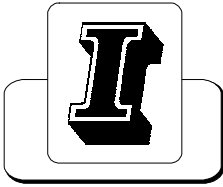

## 1.2 TECHNICAL CHARACTERISTICS

### RF

Frequency range	470 - 860MHz
Output power	1300W PEP
Video/Sound power ratio	10/1
Out stage technology	Solid State LDMOS
Vision-Sound amplification	Common
I.M.D. (-8, -10, -16dB)	Better than -54dB
Standards	G, K, N
Spurious and harmonics level	In compliance with CCIR rec.
RF Output impedance	50Ω
RF Output connector	7/16"

### GENERAL

Power supply	230Vac, ±10%, 50/60Hz 400Vac 3P+N (on request)
Power consumption	3400VA at black level
RS232 Socket	DB9 Connector (on front panel)
RS485 Socket	DB9 Connector (on rear panel)
Telemetry socket	DB9 Connector (on rear panel)
AGC Socket	DB9 Connector (on rear panel)
Power factor	>= 0.9
Ambient temperature	-5° to +45°C
Relative humidity	20% - 90%
Altitude	Up to 2.500 meters
Cooling	Forced air
Cabinet	Rack 19"-6U
Dimensions	760x263x266mm
Weight	70kg

### PROTECTION THR.

FWD Power	1500W
REF Power	150W
Unbalancing	350W
Temperature	75°C
$I_{DC}$	25A
$V_{DC}$	Min 10V - Max 33,5V

---

This page is intentionally blank

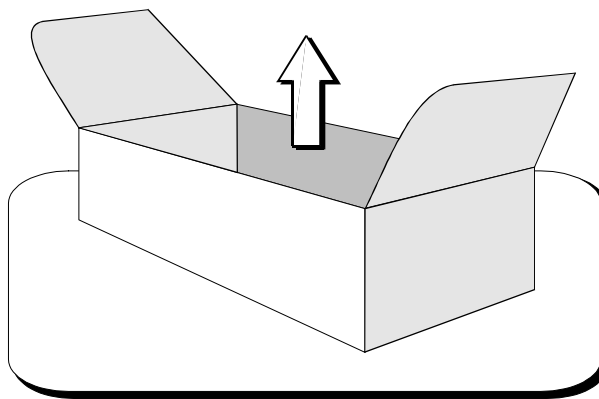

## ***Section 2 - Installation***

### *Contents:*

- 2.1 Operating environment*
- 2.2 Preliminary operations*
- 2.3 Telemeasuring socket connections*
- 2.4 RS232, RS485 and AGC socket connections*
- 2.5 Preventive maintenance*
  - Front panel*
  - Rear panel*

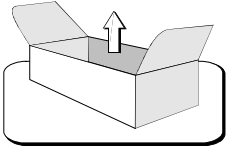

## 2.1 OPERATING ENVIRONMENT

You can install the apparatus in a standard component rack or on a suitable surface such as a bench or desk. In any case, the area should be as clean and well-ventilated as possible. Always allow for at least 2 cm of clearance under the unit for ventilation. If you set the apparatus on a flat surface, install spacers on the bottom cover plate. If you install the apparatus in a rack, provide adequate clearance above and below. Do not locate the apparatus directly above a hot piece of equipment.

## 2.2 PRELIMINARY OPERATIONS

Correct installation of the equipment is important for maximum performance and reliability. Antenna and earth connections must be installed with the greatest care. The equipment adjustment isn't need, because the unit is completely adjusted by our technical staff. This is the installation procedure:

1. connect the power supply cable of the exciter to the auxiliary socket on the rear panel of the amplifier;
2. connect the power supply cable of the amplifier to the electric network (230VAC). If there is the Isolator Transformer, the amplifier is provided with cable and plug;
3. connect the exciter / antenna cables respectively to the RF IN and RF OUT on the rear panel of the amplifier.

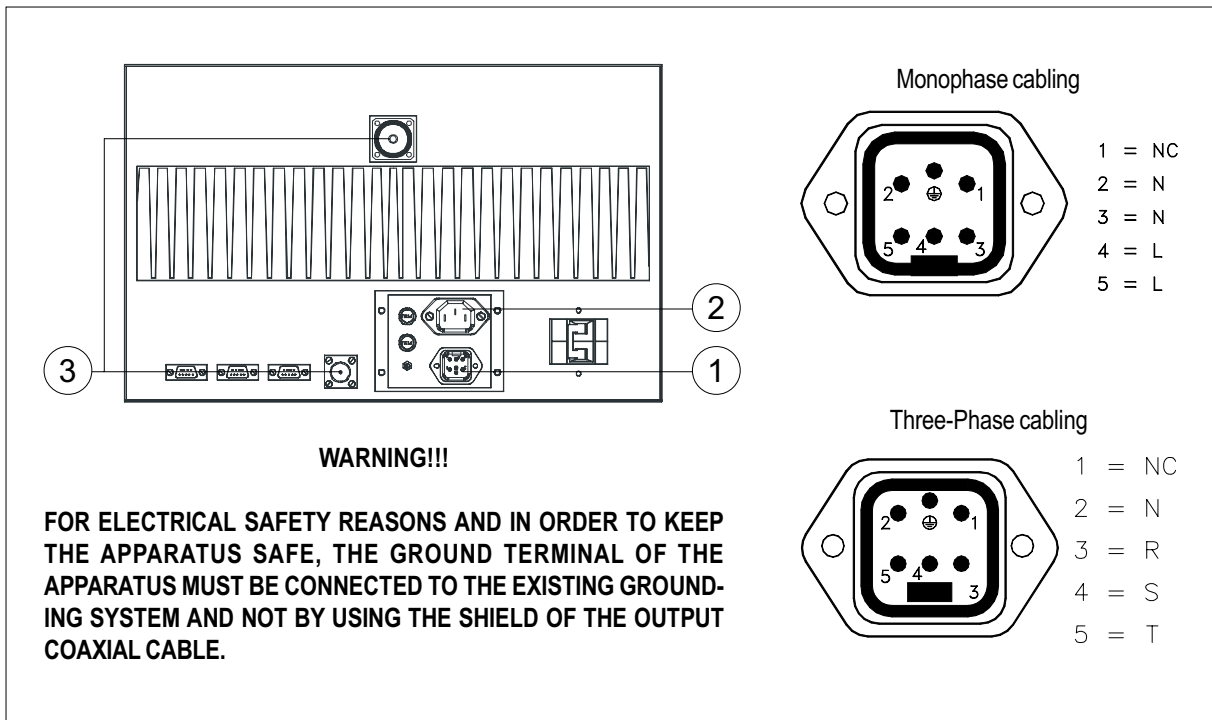

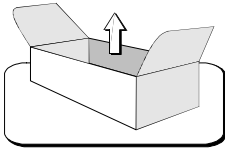

When the apparatus is put within a combined system it is directly connected to the input splitting and output combining systems.

Before fully powering the apparatus, check that the output connections of the coaxial cable to the antenna system are working.

In order to this it is possible to check the indication of the reflected power at low power levels. Only if the SWR indication on the display is 0, the output power can be slowly increased. At maximum output power, some watts might be shown as reflected power.

### 2.3 TELEMEASURING SOCKET CONNECTIONS

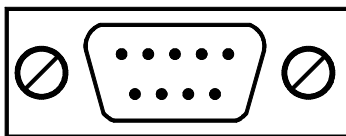

DB9 Socket

PIN N°	SIGNAL TYPE	IN / OUT	FUNCTION
1	Analog	Output	FWD Power
2	Analog	Output	REF Power
3	Digital	Output	Temperature
4	Digital	Input	Interlock
5	GND	-	-
6 - 7	Digital	Output	Free contact (closed when alarm)
8	Digital	Input	0V = ON 5V = Normal
9	Digital	Input	0V = OFF 5V = Normal

### 2.4 RS232, RS485 AND AGC SOCKET CONNECTIONS

PIN	1	2	3	4	5	6	7	8	9
FUNCTIONS	-	TxD	RxD	-	GND	-	-	-	-

RS232 - DB9 Socket

PIN	1	2	3	4	5	6	7	8	9
FUNCTIONS	-	Rx-	Rx+	5V	GND	-	Tx-	Tx+	-

RS485 - DB9 Socket

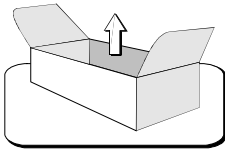

---

PIN N°	SIGNAL TYPE	IN / OUT	FUNCTION
1	GND	-	-
2	Digital	Output	0V = Normal 5V = AGC Alarm
3	Digital	Output	0V = Normal 5V = AGC Alarm
8	Analog	Output	FWD Power
9	Analog	Output	FWD Power

AGC - DB9 Socket

## 2.5 PREVENTIVE MAINTENANCE

To ensure maximum performance and minimum repair trouble, we strongly recommend you to follow the below stated headlines for preventive maintenance:

1. check antenna installation and ground connection at regular intervals;
2. keep your apparatus clean and dry externally: this will ensure continuous functioning of the front panel controls;
3. if the apparatus has not been used for a long period of time combined with exposure to extreme environmental conditions, open the unit and make a visual inspection.

Remove salt, water or ice with a moist cloth before turning the apparatus on. Check that the cooling fans are running freely.

4. for general maintenance and top performance, call an authorized service technician to give the apparatus and the complete antenna/earth connection installation a general check every 12-18 months;
5. check at regular intervals that the air intake located on the front panel is free of dust. If there is visible dust, remove it by means of a soft brush.



**Front panel**

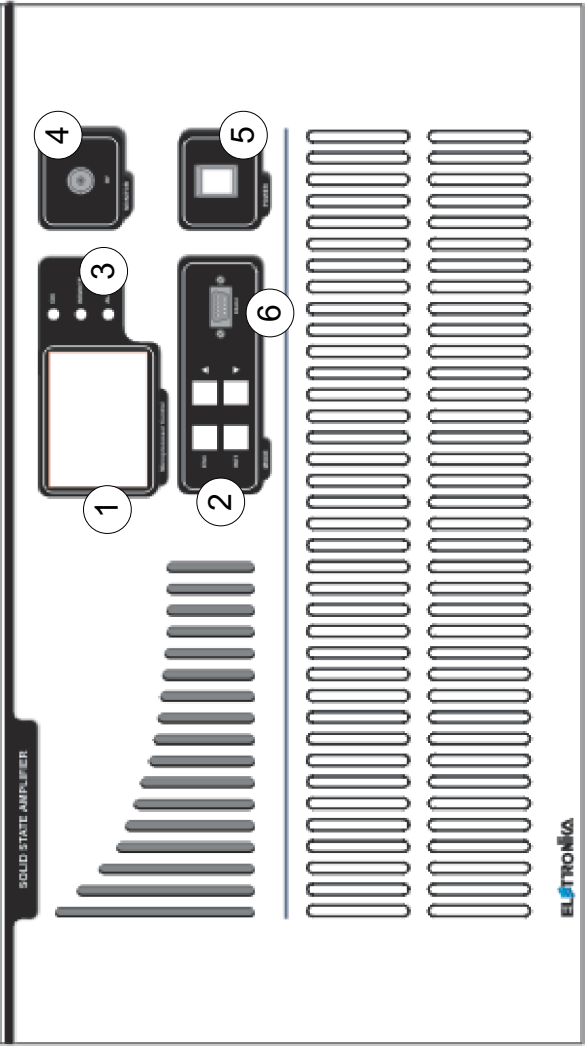

**DESCRIPTION**

1	LCD Display
2	Function keys
3	Status LEDs
4	RF Monitor connector
5	Main switch
6	RS232 Socket

## Rear panel

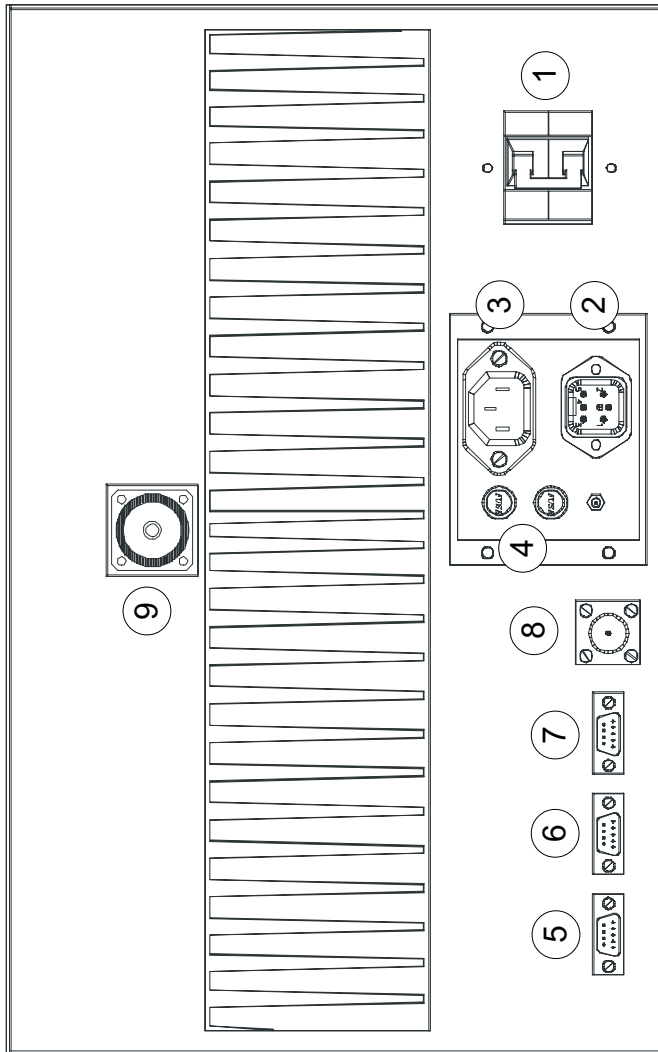

### DESCRIPTION

1	Breaker
2	Power supply socket
3	Auxiliary socket
4	Fuse
5	RS485 Socket
6	AGC Socket
7	Telemeasure socket
8	RF Input connector
9	RF Output connector

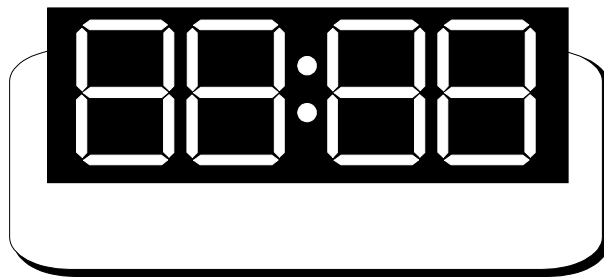

## ***Section 3 - Operation***

*Contents:*

- 3.1 Control board and display description*
- 3.2 Operation*
- 3.3 Display*
- 3.4 Menu*



### 3.1 OPERATION

At startup, after intro image, the display shows the main screen, showing the RF powers as in Figure 1:

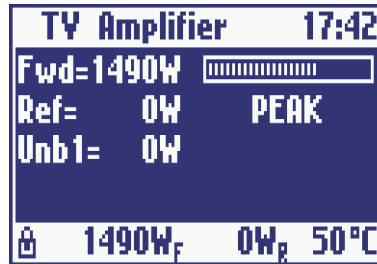

Figure 1: Main screen

The user may turn on and off the amplifier by means of the switch on the front panel. The control board turns on all the power supplies, the exciter, if any, and the cooling fans. While the amplifier is working, the micro-controller monitors continuously the most important parameters: power supply voltages, absorbed currents, temperature, forward and reflected power, unbalances, if any. Each signal is associated to a maximum threshold beyond which the amplifier is immediately put in protection status by turning off one or more power supply, depending on the failed block. In order to prevent a temporary problem to trigger a definitive protection status, the failed block is turned on again for up to five times. If it goes beyond the protection threshold for more than five times, it is declared as FAILED and will no longer be turned on. In this case the amplifier will have to be turned off manually by means of the switch on the front panel, then turned on again after performing the needed maintenance. On the front panel there are also three LEDs labelled ON, REMOTE and ALARM. Their meanings are explained below.

LED	COLOUR	MEANING	MEANING WHEN BLINKING
ON	Green	The amplifier is on	The amplifier has been turned on locally but it has been turned off by remote
REMOTE	Yellow	Remote control is enabled	It never blinks
ALARM	Red	Alarm status	It never blinks

Table 1: Meanings of the three LEDs on the front panel

<sup>1</sup> Screenshots in this manual are indicative and they refers to a TV amplifier, so they can be different from those on your equipment.



### 3.2 DISPLAY

The control board is provided with a modern 128x64 pixels graphic display with blue backlight. Normally it always shows a title bar (on the top line) and a status bar (on the bottom line).

The title bar, see Figure 2, shows the name of the amplifier (TV Amplifier or FM Amplifier) and the current time.



Figure 2: Title bar

The status bar indicates the forward and reflected power and the temperature. It also contains two symbols for the interlock (lock) and a generic alarm (bell).



Figure 3: Status Bar

The bell symbol is displayed in case of alarm. It blinks if there has been an alarm which has ended but has not yet been seen by the user. It stops blinking once the alarm Log has been checked.

The interlock symbol is displayed only when the check for this alarm is enabled. It may be either a close lock, see Figure 3, when there is no alarm (close interlock chain) or an open lock in case of alarm (open interlock chain).

Since the status bar is always on the display, regardless of the displayed screen, the user may monitor at any moment the most important parameters and the presence of alarms, if any, while moving between different screens.

### 3.3 MENU

The user may see or modify locally some configuration parameters of the apparatus by means of the four keys on the front panel. All screens are made up by hierarchical menus and the user may move between them in a simple and intuitive way.

To see the main menu it's sufficient to press ESC key (see Figure 4).

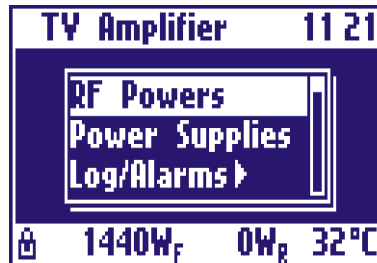



Figure 4: Main menu

The display only shows three items, but the whole menu can be scrolled by means of the UP and DOWN arrow keys. Any item can be chosen by selecting it and pressing the RET key. Menu entries with arrow on the right  open sub-menus when chosen. Thus there is a hierarchical structure as in Figure 5. To go back from a sub-menu to the previous menu, press the ESC key. If the ESC key is pressed in the main menu, the main powers screen is accessed.

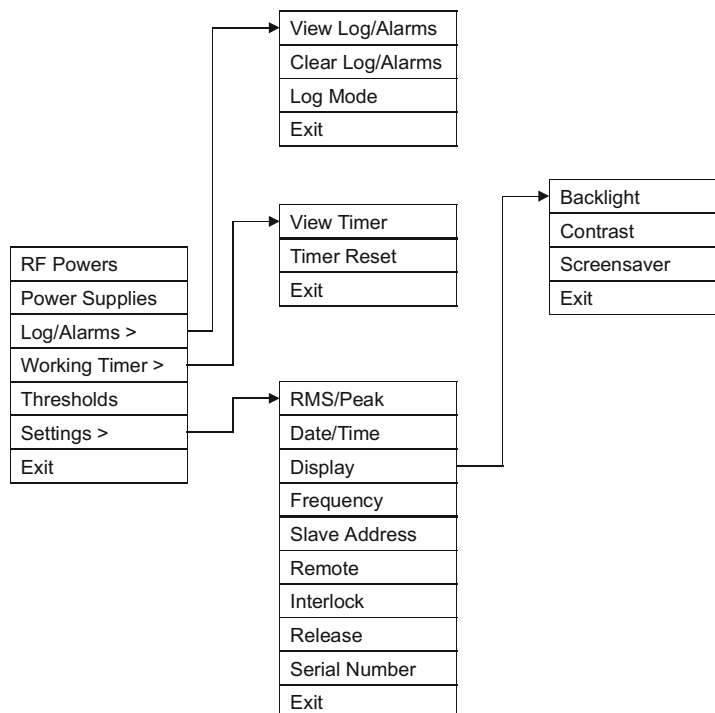

Figure 5: Hierarchical menu structure

All menu items are described in detail below.



### - RF Powers

This is the main screen showing the RF powers of the amplifier: forward power, reflected power, unbalances, if any. For forward power a level bar is displayed. See example in Figure 1.

### - Power Supply

This screen shows all the signals coming from the power supply. To check a different power supply press the UP (or DOWN) key to see the next (or previous) one. For each power supply, the two voltages, the two absorbed currents and the status (ON or OFF) are shown.

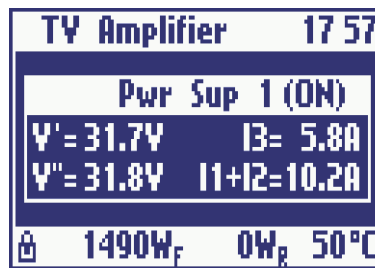

Figure 6: Power supply screen

### - Log/Alarms

The control board is provided with an external EEPROM and a clock. Any alarm or switching event is saved into an event log stored inside the EEPROM and associated to the time at which it occurred. The Log/Alarms sub-menu allows to manage this log.

It is possible to see the events stored in the log by selecting Log/Alarms → View Log/Alarms. All events can be scrolled by pressing the UP and DOWN keys. The event shown in Figure 7 is the turning on of the amplifier by means of the local switch. Each event is associated to the date and time at which it occurred and to a description.

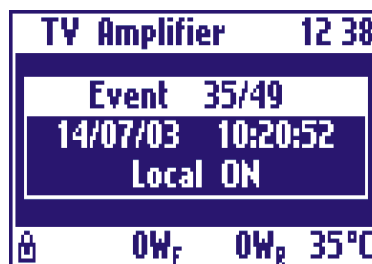

Figure 7: Event stored in the log



In case of alarm on a parameter, the value of the parameter which caused the alarm is saved into the log. In case of alarm still existing after five turning-on attempts, the parameter is marked as FAILED. Table 2 is the list of all the events which can be logged.

EVENT	DESCRIPTION
Local ON	Amplifier turned on by means of the local switch
Local OFF	Amplifier turned off by means of the local switch
Remote ON	Amplifier turned on remotely
Remote OFF	Amplifier turned off remotely
Interlock opened	Interlock chain opened
Interlock closed	Interlock chain closed
Power Supply ON	Power supply on
Fwd Pwr xxxW	Alarm for forward power
Ref Pwr xxxW	Alarm for reflected power
UnbY xxxW	Unbalancing alarm
Pwr Sup x: V1 xx.xV	Power supply voltage alarm
I1 xx.xA	Power supply current alarm
Pwr Sup x: OVERVOLT	Power supply overvoltage alarm
Pwr Sup x: OVERTEMP	Power supply overtemperature alarm

Table 2: Events managed and logged by the control board

The log may be completely deleted by selecting Log/Alarms → Clear Log/Alarms. Amplifier can store in the log details about alarms and generic events. You can change this behaviour selecting Log/Alarms → Log/Mode menu item.

### - Working Timer

The control board has a working timer which is always enabled while the amplifier is working (i. e. there is at least one power supply working). The menu entry Working Timer → View Timer allows to check the hours for which the timer has been enabled. Working Timer → Timer Reset resets the timer.

### - Thresholds

This is a screen showing the alarm threshold of each and all signals monitored by the control board. The list can be scrolled by means of the UP and DOWN keys.





### **- RMS/Peak**

The control board can monitor both the RMS and peak powers. The menu entry Settings → RMS/Peak allows to choose the power to be displayed and monitored.

### **- Date/Time**

This screen allows to set the current date and time. The setting is changed by pressing the arrow keys, then pressing the RET key to move to the following setting and eventually save the changes. To go back to the previous menu and discard any change made, press the ESC key. Figure 8 shows an example of this screen.

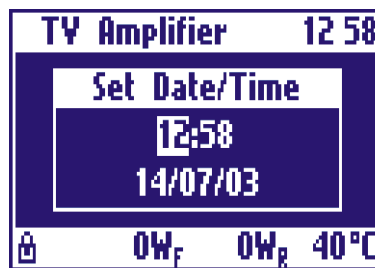

Figure 8: Date and time setting screen

### **- Display**

The menu entry Settings → Display allows to change some settings of the display, such as back light, contrast and screensaver. The back light and the contrast are set by means of the UP and DOWN arrow keys. The changes made are saved by pressing the RET key or discarded pressing the ESC key. Figure 9 shows the contrast screen.

With Settings → Display → Screensaver you can set an interval time after which display backlight is turned off. When display backlight is off, press any key to switch it on.

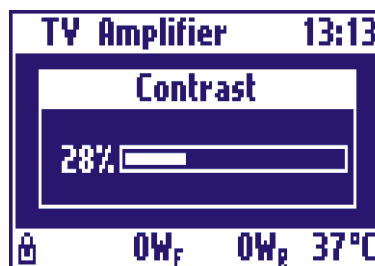

Figure 9: Display contrast setting screen



### - *Frequency (only for some Amplifiers)*

The forward and reflected RF power is measured by means of a directional coupler. In order to compensate for the effect due to the sampling made by the coupler, it is possible to set the frequency by means of the menu entry Settings → Frequency. The setting can be changed by pressing the arrow keys. The changes made are saved by pressing the RET key or discarded pressing the ESC key. In a TV Amplifier, set the video carrier frequency.

### - *Slave Address*

The amplifier may be used either in stand-alone mode or as slave of a master within a multiple transmitter. In the latter case an unique address for each amplifier has to be specified, in order for all of them to communicate with the master on the same RS485 bus. The menu entry Settings → Slave Address allows to choose the stand-alone mode or set a slave address by means of the UP and DOWN arrow keys. The changes made are saved by pressing the RET key or discarded pressing the ESC key. This screen is shown in Figure 10.

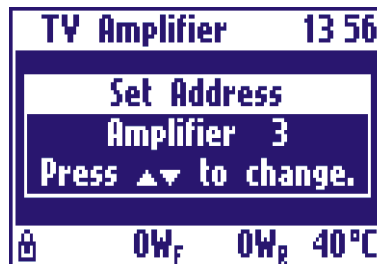

Figure 10: Slave address setting screen

### - *Remote*

The amplifier may be controlled either locally, by means of the keys and display, or remotely. There are three possibilities for remote control:

- using a direct serial connection between amplifier RS232 connector and a PC RS232;
- using the remote control device manufactured by Elettronika S.r.l. (RCU), on the RS485 bus;
- using a general-purpose control system connected to telemeasures.

You can enable / disable remote control choosing menu item Settings → Remote. When remote control is enabled, the yellow REMOTE LED on the front panel is lit.

### - *Interlock*

One of the pins of the telemeasure connector, located on the rear panel, is for the interlock alarm. It is an input line which turns off the amplifier in case of alarm. The interlock check can be enabled or disabled using menu



item Settings → Interlock. When it is enabled, the status bar shows the lock symbol (see Figure 3), which is close if the interlock chain is closed (no alarm) or open if it is open (alarm).

**- Firmware Release**

The menu entry Settings → Firmware Release allows to display the firmware version number and the hardware release of the amplifier.

**- Serial Number**

The menu entry Settings → Serial Number allows to display the serial number of the apparatus.

---

This page is intentionally blank

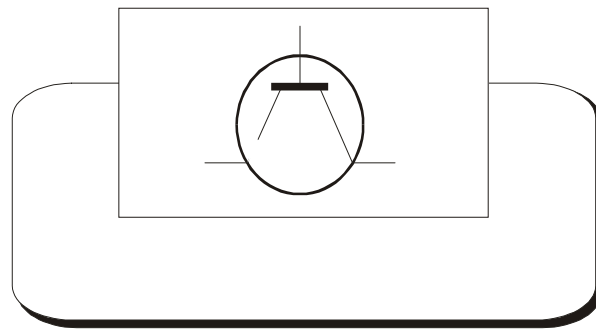

## **Section 4 - Diagram**

*Contents:*

- *Cable diagram*
- *AUTV/1500LD Component layout*
- *RF Section Block Diagram*
- *MTF0070BR0 Amplifier module - Component list*
- *SCH0192AR0 (200W UHF LDMOS Amplifier module)*
- *SCH0223AR1 (Control board and display)*
- *SCH0221AR1 (Amplifier interface)*
- *SCH0215AR0 (Mains distribution board)*
- *E0026 (1kW 32Vdc Switching power supply)*

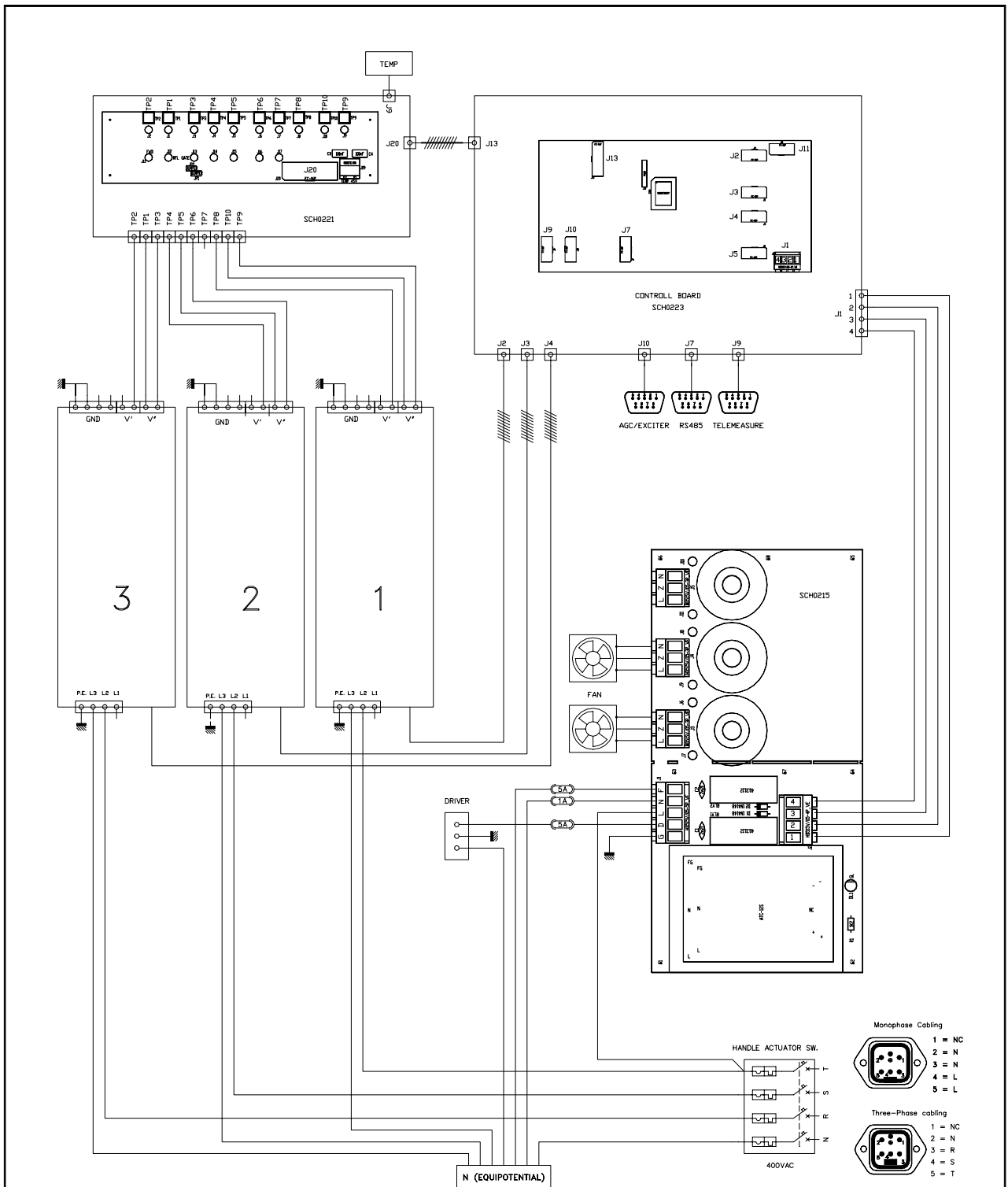

	DESCRIPTION	DESIGNER	Sign.	DATE
	AUTV/1500LD LDMOS UHF TV AMPLIFIER Cable Diagram	COLASUONNO		18/07/2003
CODE	TITLE	PCB DESIGNER	Sign.	REF
	Schema Cablaggio AMPLIFICATORE TV UHF LDMOS AUTV/1500LD	COLASUONNO		
APT117B		QUALITY CONTROL	Sign.	SHEET
		RUSSO		1/1

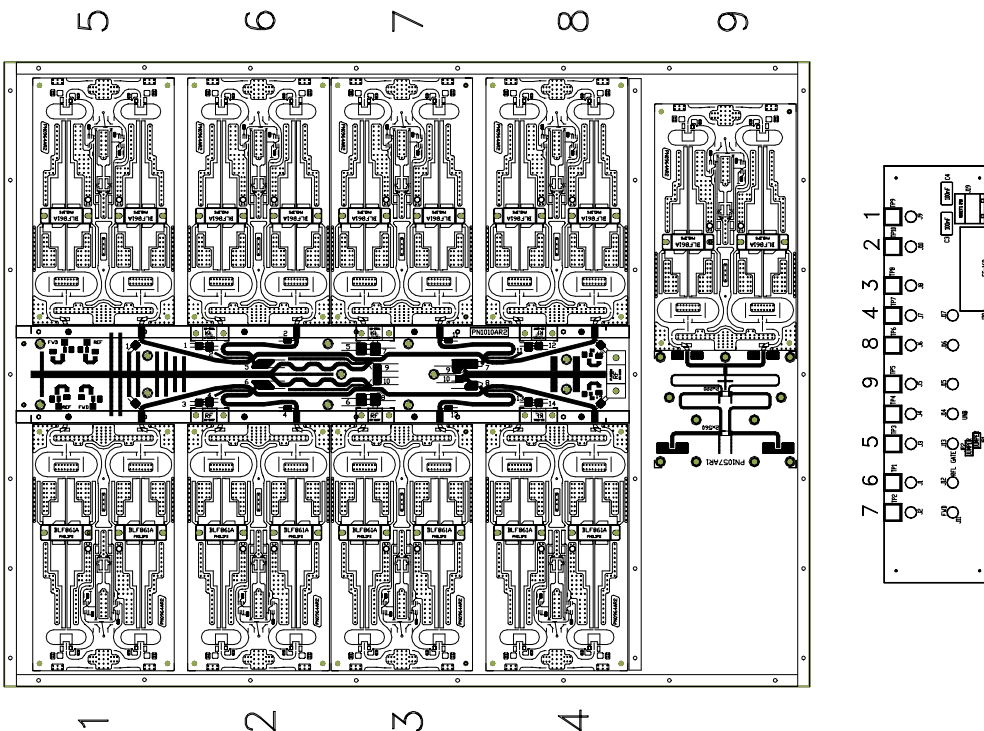
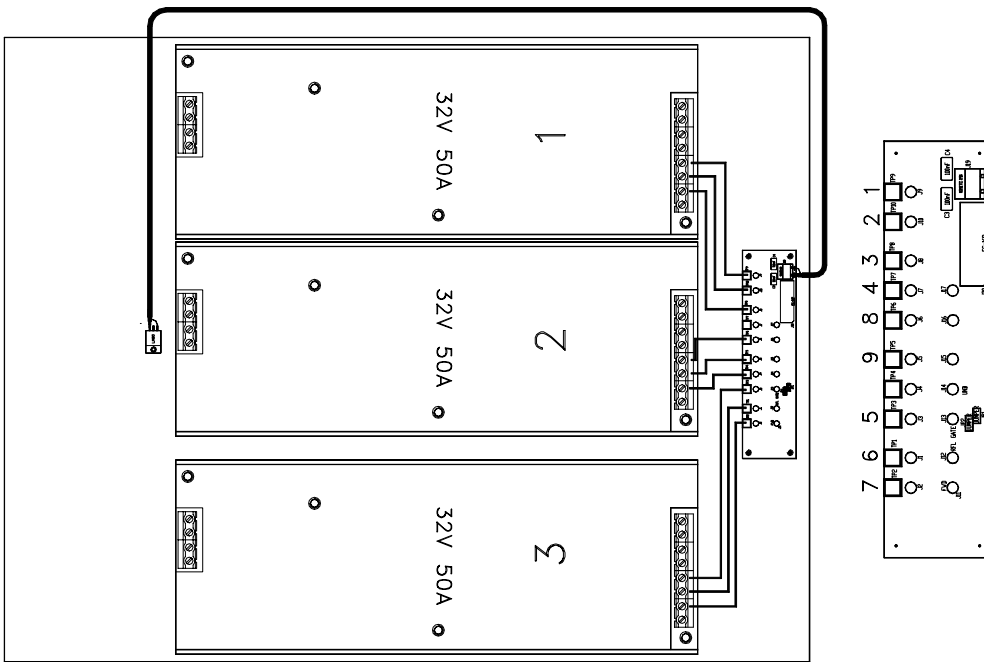

	DESCRIPTION	DESIGNER	Sign.	DATE
	AUTV/1500LD LDMOS UHF TV AMPLIFIER Component Layout	COLASUONNO		18/07/2003
CODE	TITLE	PCB DESIGNER	Sign.	REF
	Piano di Montaggio AMPLIFICATORE TV UHF LDMOS AUTV/1500LD	COLASUONNO		
APT117B		QUALITY CONTROL	Sign.	SHEET
		RUSO		1/1

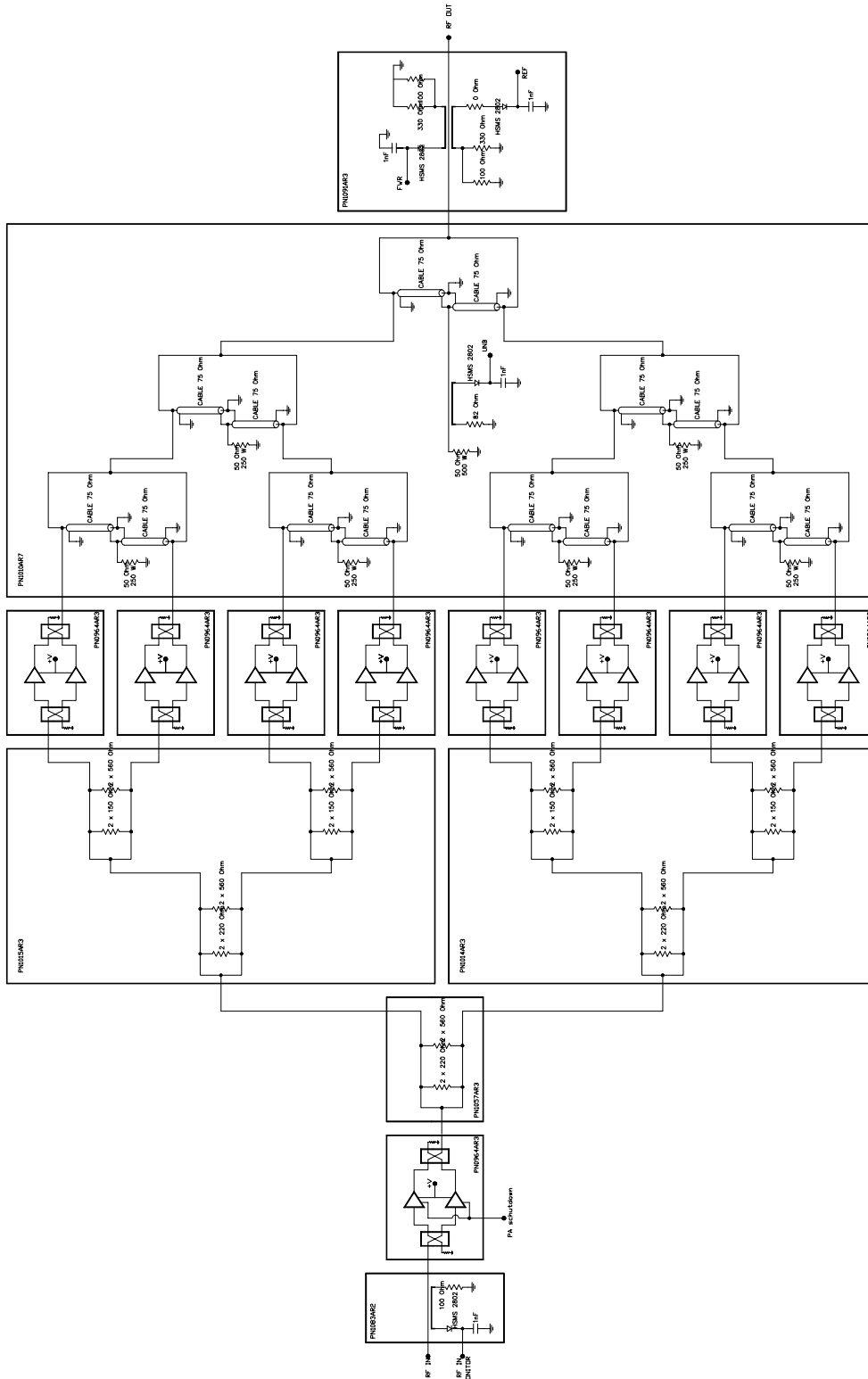

 CODE MTF0070BR0	DESCRIPTION	DESIGNER	Sign.	DATE
	TITLE	PCB DESIGNER	Sign.	REF
	Schema a Blocchi Sezione RF MTF0082AR0 MODULO AMPLIFICATORE	QUALITY CONTROL	Sign.	SHEET
		CAMPANA		18/07/2003
		CAMPANA		REF
		RUSSO		AP11178_AUTY_1500LD.dwg
				1/1



**Component list****MTF0070BR0 Amplifier module**

<b>Part Name Code</b>	<b>Description</b>	<b>Qty</b>
00001	0Ω 1206 SMD RESISTOR	2
01041D	1nF 1206 2% SMD CAPACITOR	2
00221B	75Ω 1206 1% SMD RESISTOR	2
03207	HSMS-2802*L31 DIODE	2
SCH0192AR0	200W UHF LDMOS AMPLIFIER MODULE	9
SCH0221AR0	AMPLIFIER INTERFACE	1
SCH0248AR0	8 WAY WILKINSON	1
SCH0249AR0	4 WAY WILKINSON Dx	1
SCH0250AR0	4 WAY WILKINSON Sx	1
SCH0251AR0	2 WAY WILKINSON	1
SCH0252AR0	1500W UHF INPUT COUPLER	1
PN1091A	C.S. PN1091AR3 OUTPUT DIRECTIONAL COUPLER	1
02402	7/16" FEMALE CONNECTOR cod. 0142	1
02512	J01151A0531 SMA SOCKET WITHOUT BAT.	1
01400	2499-003-X5U0-102M FEED-THROUGH CAPACITOR	14
01408	5000PF FEED-THROUGH CAPACITOR	2
DET0726	DET0726R2 SIDE x 1500W UHF AMP. MOD.	2
DET0727	DET0727R1 INTERNAL FRONT SIDE x AMP. MOD.	1
DET0728	DET0728R4 INTERNAL SIDE x AMP. MOD.	2
DET0729	DET0729R2 FRONT SIDE x AMP. MOD.	1
DET0730	DET0730R2 REAR SIDE x AMP. MOD.	1
DET0732	DET0732R1 CONNECTIONS SUPPORT BOARD	1
DET0734	DET0734R0 COVER x AMPLIFIER MODULE P. 2634	1
DET0736	DET0736R5 HEATSINK x AMPLIFIER MODULE	1
DET0807	DET0807R3 SCREEN DIR. COUPLER MODULE	1
DET0810	DET0810R0 PART. x DIRECTIONAL COUPLER	1
DET0811	DET0811R1 COVER x DIRECTIONAL COUPLER	1
DET0812	DET0812R1 TEFLON RING x DIRECTIONAL COUPLER	1
DET0819	DET0819R0 SPESS. x INPUT DIR. COUPLER	1
DET0828	DET0828R0 COVER x AMPLIFIER MODULE P. 2644	1
DET0839	DET0839R2 DIRECTIONAL COUPLER	1
08502	RG316 50Ω CABLE	3,00
08527	HF-85 ENDIFORM CABLE	0,20

---

This page is intentionally blank

**Component list****APT117B - AUTV/1500LD**

<b>Part Name Code</b>	<b>Description</b>	<b>Qty</b>
DET0516	DET0516R0 SUPPORTO PRESE ZN	1
E0026	ALIM. SWITCHING 1kW 32VDC mod. PBIT2129	3
V0958	ACCESSORIO GUIDA DIN ELECO E205	2
V0962	MORSETTIERA/GIUNZIONE ELECO E806	1
Z0081B	TAV... SUPPORTO INT. MAG. QUADRIPOL.	2
Z0673	TAV. 1199 CHIUS. CONT. PROF. 775 ZN	2
MTF0070BR0	MOD. AMPLIFICATORE 1500W LDMOS UHF	1
02830	PRESA VDE 10A cod. PX675 A63	1
02876	PRESA VOLANTE ILME 16A PENTAPOLARE 3mt	1
02877	SPINA A PANNELLO ILME 16A PENTAPOLARE	1
07524A	INTERR. NERI I3910	1
07515	INTER. AUTOM. 4*16A 4.5KA 23902	1
07541	PORTAFUS. 10A PANN. cod. P1820	3
07925	PROTEZIONE IN GOMMA OVC PG 075	1
08500	CAVORG174 50 Ohm	1,40
FUS1A	FUSIBILI 1A 5x20 RITARDATI ST520210	1
FUS5A	FUSIBILI 5A 5x20 RITARDATI ST520250	1
PAN0074	PAN0074AR0 PANN. 6U AMPLIFICATORE LDMOS	1
05553B	KIT MANIGLIE 5-6U cod. 235.013	2
Z0021	TAV. 635/A TOND. OTT. x INT. MAGNET.	2
07605B	VENTOLA D2E097-BI56-48	2
07605A	COND. 2uF	2
02228	GE 15145 D/60 NF A VITONE	1
02699	CONNETTORE cod. 534-2301 FEMM. 10 VIE	9
02695	CONNETTORE DB9F x CAVO 525-2810	3
00664	SENSORE TERMICO LM 35DT	1
SCH0223AR1	SCHEDA CONTROLLO AMPLIFICATORI PBOX2003	1
SCH0215AR0	SCHEDA DISTRIBUZIONE RETE	1
CON0178	CON0178R2 POSTERIORE 1500W LDMOS UHF	1
CON0179	CON0179R1 LATERALE 1500W LDMOS UHF	2
FUS3A	FUSIB. 3.15A 5x20 RITAR. ST520231	1
02502	J01150A0041 SMA x RG58/c	1
07605F	GRIGLIA 09485-2-4039	4
08503	CABLE RG303 50 Ohm	1,20
DET0771	DET0771R0 CANALINA COPERTURA CAVI	1
DET0772	DET0772R0 BARRETTA FISSAGGIO VENTOLE	1

---

This page is intentionally blank

**DESCRIPTION**

The RF module is an integrated TV linear amplifier designed for UHF band, this module employs push-pull LDMOS technology in order to achieve very good efficiency, high linearity and reliability.

LDMOS transistors operate in AB class. It is a wideband amplifier over the full frequency, no adjustment is required for the channel change. The board includes RF section amplifier, bias circuit, protection circuit and matching networks. A silver plated copper plate is brazed with PCB in order to obtain low thermal resistance. Providing a minimum of 200W Pk sync linear power, this module is the perfect amplifier for any broadband UHF power transmitter.

**TECHNICAL CHARACTERISTICS**

Output power	300W max
Input power	15W max
Frequency	470 - 860MHz
Gain	> 13dB
LDMOS Power supply	32V±2%
LDMOS Bias current @+32V Vdc	2A
RF Input impedance	50Ω
RF Output impedance	50Ω
Input / Output return loss	>= 15dB
Drain efficiency	47% @ 250W
Storage temperature range	-50° to +150°C
Dimensions (LxWxH)	165x95x29mm

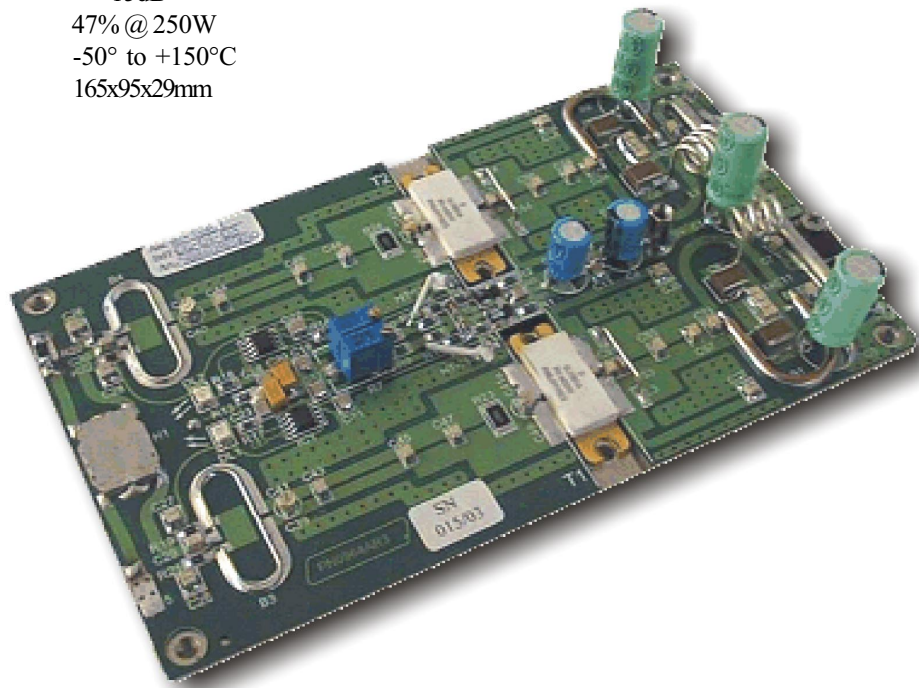

**- Curve response graphic**

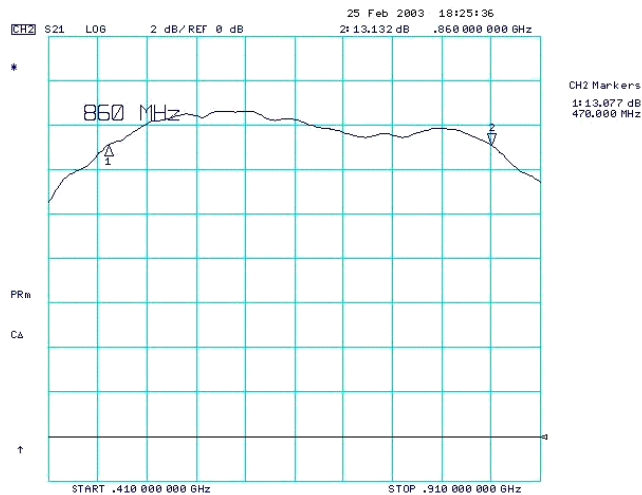

Middle frequency 660MHz, span 500MHz, 2dB/div., reference to the arrow

**CALIBRATION PROCEDURE**

**- Technical characteristics**

Power supply voltage	32V ( $\pm 2\%$ )
Polarisation current	1.0 cold for each device (2A total), $\pm 0.1A$
Gain for low signal	Not less than 13dB in the 470-860MHz band ( $\pm 1dB$ ) Compare to the typical curve enclosed

**- Adjustment procedure**

Polarisation current calibration	32V stabilised power supply 10A amperometer
Gain curve	Network analyser

**- Adjustment points description**

R7-R8 (Trimmers)	Adjust the current absorbed in stand-by (1.0A per device)
------------------	---

## - Calibration steps

STEP 1. **Close the input and the output of the module by connecting them to a 50Ω dummy load** and connect the spectrum analyser through a directive sample, in order to look for self-oscillation of the module, if any (anyway the module has been designed so that it would not self-oscillate even if totally decoupled, without any input or output load).

STEP 2. **Check the voltages of the polarisation circuits *without assembling the transistors first*:** connect the 32V power supply to the proper turret by means of a fastening screw, then give power and check data:

- the stabilised voltage on the zener diodes DZ1 and DZ2 is about 15V compared to the ground;
- the stabilised voltage on the zener diodes DZ3 and DZ4 is about 6.8V compared to the ground;
- the voltage on the pads to which the gates of the LDMOS transistors will be soldered (R23 and R24 resistors side) changes from 0V to a maximum value of about 6V when moving the relevant trimmer (R7-R8).

STEP 3. **Check the work of the protections.**

- Set both trimmers so that there is a value of about 4.5V on the pads of the gates;
- solder some wire to the pad between the two LEDs, next to the serigraphy of the input hybrid H1;

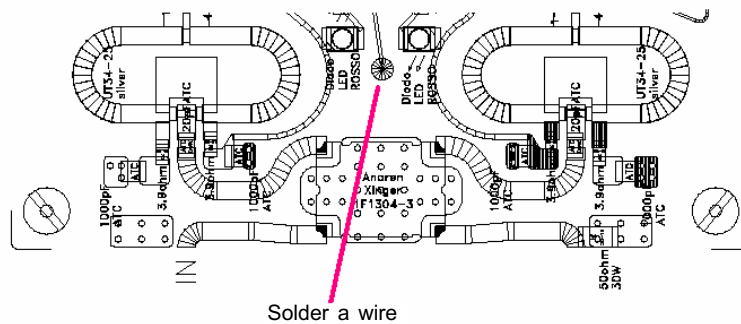

- in order to check the work of the protections aboard, a power of about 4V has to be supplied to the wire, for example by touching with it the reophore of C23 or C24 which is not connected to ground; the two red LEDs will immediately light up and the two RF transistors will be switched off at the same time: the polarisation current (2A) will decrease to 0 and of course the gain curve displayed by the spectrum analyser will decrease;
- after this it is **important** to *restore the position of the two trimmers for the minimum voltage!* Then disconnect the 32V power supply.

STEP 4. **Fastening of the LDMOS transistors:** after properly cleaning the plate surface, smear a thin layer of silicone fat on the lower side of the flange of the MOSFETs, fasten them to the heat sink and solder the gate first, then the drain. Solder the two 13pF (ATC) chip capacitors and above them the two 1-5pF

---

capacitive trimmers, between the two pair of gates, as shown by the mounting plan.

STEP 5. Connect serially a c.c. amperometer to the power supply, with scale starting from more than 5A (i.e. 10A).

STEP 6. Power the module and check the MOSFET is not absorbing current; this means that the device is integral and working correctly.

STEP 7. Slowly turn the R7 trimmer until the MOSFET absorbs 1A, always checking that there are no self-oscillation; under this conditions it is possible to check by means of a digital tester that the voltage on the gate is about 5.2-5.4V.

STEP 8. Repeat the previous step for the other section of the module, this time turnign R8 and checking that the indication of the current on the amperometer increases to 2A total (which includes the current of the other device left on).

STEP 9. Check the response curve of the module by means of the *network analyser*.

STEP 10. Check the response curve for low signal with centre 660MHz and span 500MHz, 2dB/div.

STEP 11. The curve should be similar to the one enclosed, with a tolerance of  $\pm 0.5$ dB. To obtain this, act on the four trimmers C41-C41a and C42-C42a with the proper “calibrator”, in order to flatten the curve as much as possible, especially at the edged of the band which represents the minimum values.

STEP 12. Finally, check that the current in stand-by does not increase by more than 15÷20%, reaching at worst 2.3÷2.4A when the heat sink is hot and not ventilated.

*Note: when mounting-removing the PALLET on the heat sink, tightly fasten the screw of each all “N” input and output connectors. These are mounted with a single 3mm screw and if it is not properly fastened it may be detached from the PCB by a movement of the connector once it has already been soldered to the path.*



Component layout SCH0192AR0

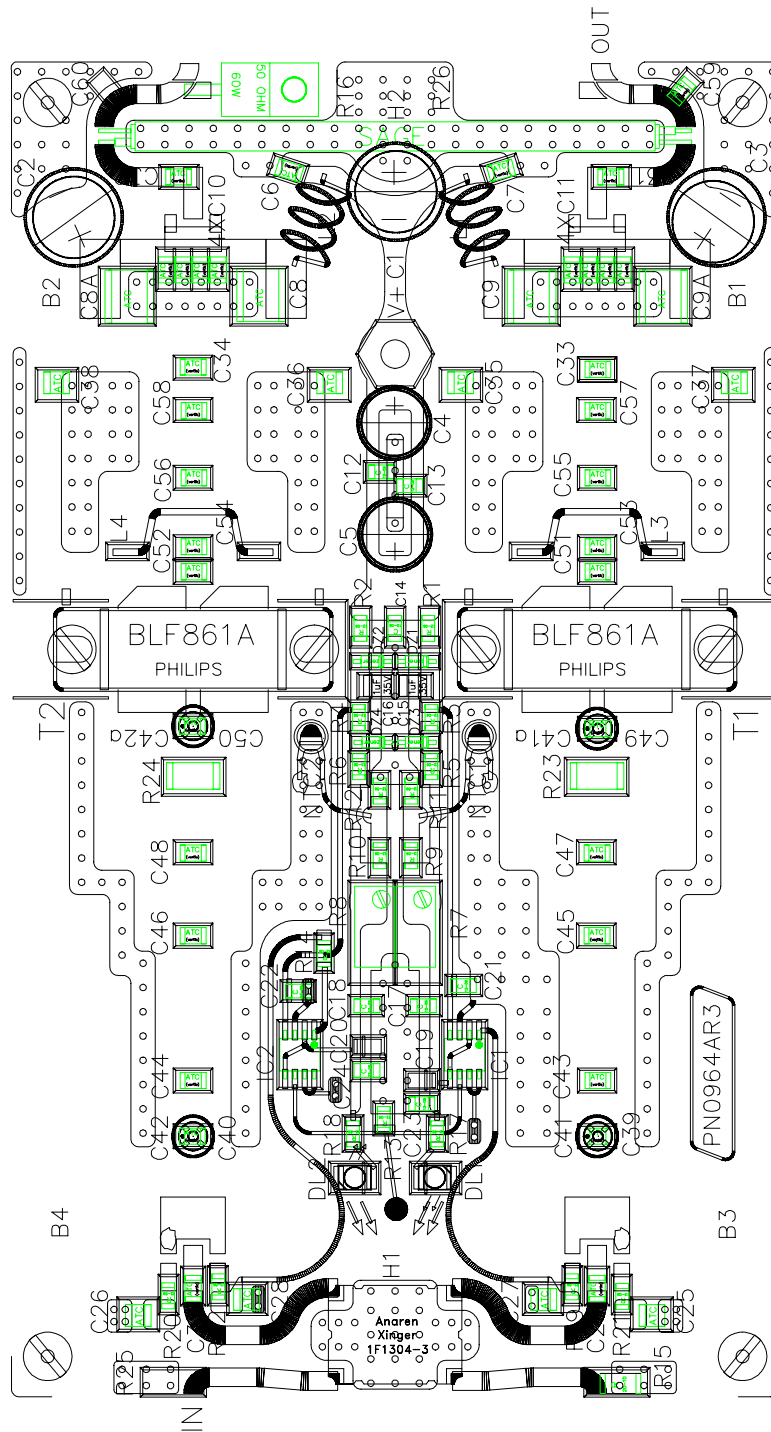

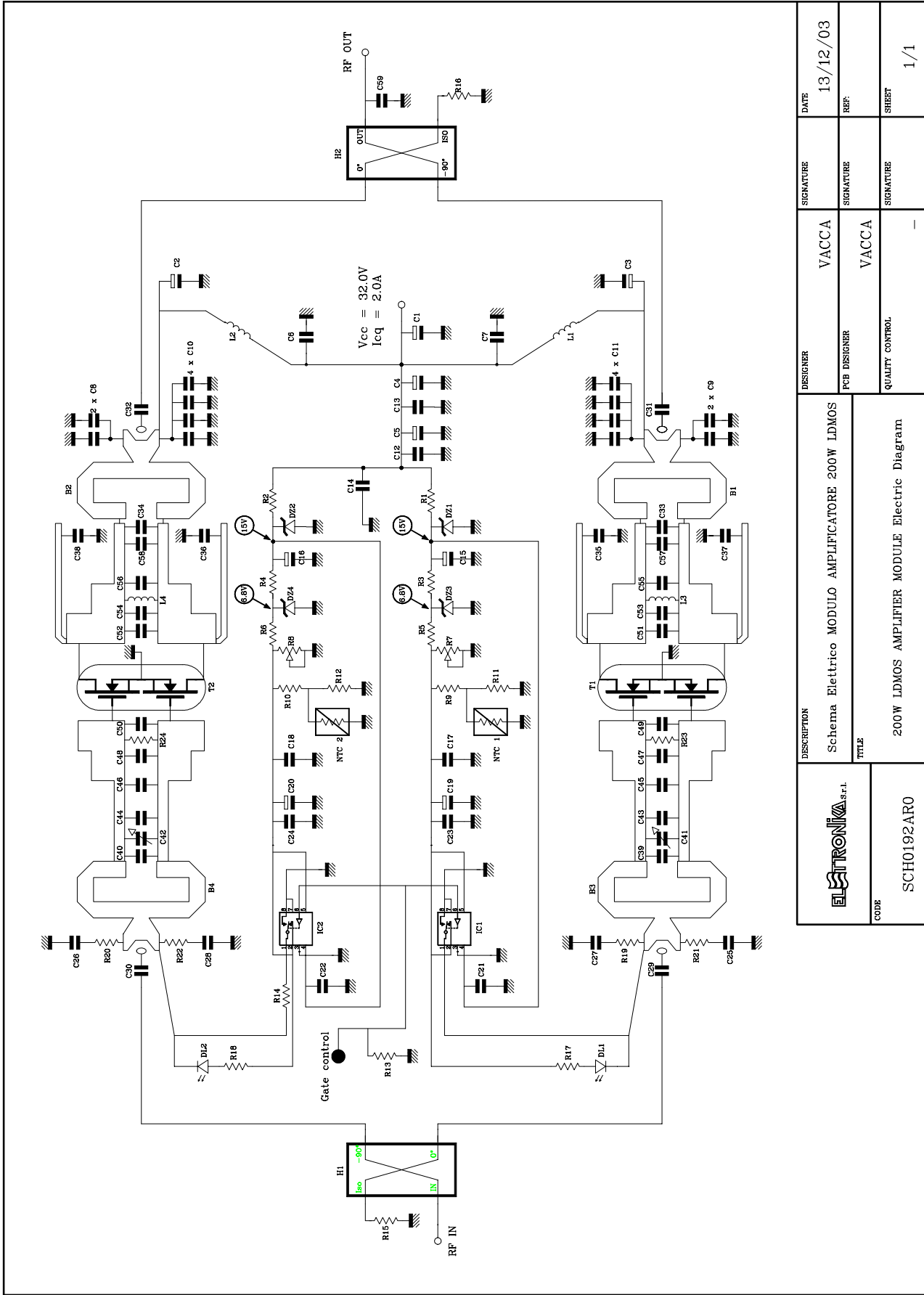

<b>ELSTRONIKA</b> S.p.A. CODE SCH0192ARO	DESCRIPTION Schema Elettrico MODULO AMPLIFICATORE 200W LDMOS	DESIGNER VACCA	SIGNATURE SIGNATURE	DATE 13/12/03
	TITLE 200W LDMOS AMPLIFIER MODULE Electric Diagram	PCB DESIGNER VACCA	SIGNATURE SIGNATURE	REF. SHEET 1/1
		QUALITY CONTROL —		

## COMPONENT LIST SCH0192AR0

REF.	DESCRIPTION	ELETTRONIKACODE	Page 1/3
R1	2200Ω 1/4W 1206 SMD RESISTOR	00045A	
R2	2200Ω 1/4W 1206 SMD RESISTOR	00045A	
R3	2200Ω 1/4W 1206 SMD RESISTOR	00045A	
R4	2200Ω 1/4W 1206 SMD RESISTOR	00045A	
R5	1200Ω 1/4W 1206 SMD RESISTOR	00042A	
R6	1200Ω 1/4W 1206 SMD RESISTOR	00042A	
R7	50kΩ MULTITURNS PTH TRIMMER	00800	
R8	50kΩ MULTITURNS PTH TRIMMER	00800	
R9	1200Ω 1/4W 1206 SMD RESISTOR	00042A	
R10	1200Ω 1/4W 1206 SMD RESISTOR	00042A	
R11	18kΩ 1/4W 1206 SMD RESISTOR	00056B	
R12	18kΩ 1/4W 1206 SMD RESISTOR	00056B	
R13	680KΩ 1/4W 1206 SMD RESISTOR	00075A	
R14	0Ω 1/4W 1206 SMD RESISTOR	00001	
R15	50Ω 30W 1512EBX SMD RESISTOR	00416A	
R16	50Ω 60W	00432	
R17	4.7kΩ 1/4W 1206 SMD RESISTOR	00049A	
R18	4.7kΩ 1/4W 1206 SMD RESISTOR	00049A	
R19	3.9Ω 1/4W 1206 SMD RESISTOR	00012A	
R20	3.9Ω 1/4W 1206 SMD RESISTOR	00012A	
R21	3.9Ω 1/4W 1206 SMD RESISTOR	00012A	
R22	3.9Ω 1/4W 1206 SMD RESISTOR	00012A	
R23	1000Ω 1W 2512 SMD RESISTOR	00396	
R24	1000Ω 1W 2512 SMD RESISTOR	00396	
*R25	= R15 (da montare se si inverte l'ingresso)		
*R26	= R26 (da montare se si inverte l'uscita)		
C1	470uF 50V PTH ELECTROLYTIC CAPACITOR	01807B	
C2	470uF 50V PTH ELECTROLYTIC CAPACITOR	01807B	
C3	470uF 50V PTH ELECTROLYTIC CAPACITOR	01807B	
C4	100uF 50V PTH ELECTROLYTIC CAPACITOR	01795	
C5	100uF 50V PTH ELECTROLYTIC CAPACITOR	01795	
C6	1nF ATC 100B CAPACITOR OR EQUIVALENT	01145	
C7	1nF ATC 100B CAPACITOR OR EQUIVALENT	01145	
C8 x2	2 x 100nF ATC CAPACITOR OR EQUIVALENT	01065H	
C9 x2	2 x 100nF ATC CAPACITOR OR EQUIVALENT	01065H	
C10 x4	4 x 100pF ATC 100B CAPACITOR OR EQUIVALENT	01135	
C11 x4	4 x 100pF ATC 100B CAPACITOR OR EQUIVALENT	01135	
C12	100nF 1210 SMD CAPACITOR	1065G	
C13	100nF 1210 SMD CAPACITOR	1065G	
C14	100nF 1210 SMD CAPACITOR	1065G	
C15	1uF 35V SMD TANTALIUM CAPACITOR	01613A	
C16	1uF 35V SMD TANTALIUM CAPACITOR	01613A	
C17	100nF 1210 SMD CAPACITOR	1065G	

REF.	DESCRIPTION	ELETTRONIKA CODE	Page 2/3
C18	100nF 1210 SMD CAPACITOR	1065G	
C19	10uF 16V SMD TANTALIUM CAPACITOR	01626A	
C20	10uF 16V SMD TANTALIUM CAPACITOR	01626A	
C21	100nF 1210 SMD CAPACITOR	1065G	
C22	100nF 1210 SMD CAPACITOR	1065G	
C23	100nF 1210 SMD CAPACITOR	1065G	
C24	100nF 1210 SMD CAPACITOR	1065G	
C25	1nF ATC 100B CAPACITOR OR EQUIVALENT	01145	
C26	1nF ATC 100B CAPACITOR OR EQUIVALENT	01145	
C27	1nF ATC 100B CAPACITOR OR EQUIVALENT	01145	
C28	1nF ATC 100B CAPACITOR OR EQUIVALENT	01145	
C29	20pF ATC 100B CAPACITOR OR EQUIVALENT	01123	
C30	20pF ATC 100B CAPACITOR OR EQUIVALENT	01123	
C31	20pF ATC 100B CAPACITOR OR EQUIVALENT	01123	
C32	20pF ATC 100B CAPACITOR OR EQUIVALENT	01123	
C33	1.3pF ATC 100B CAPACITOR OR EQUIVALENT	01104	
C34	1.3pF ATC 100B CAPACITOR OR EQUIVALENT	01104	
C35	470pF ATC 100B CAPACITOR OR EQUIVALENT	01143	
C36	470pF ATC 100B CAPACITOR OR EQUIVALENT	01143	
C37	470pF ATC 100B CAPACITOR OR EQUIVALENT	01143	
C38	470pF ATC 100B CAPACITOR OR EQUIVALENT	01143	
C39	4.7pF ATC 100B CAPACITOR OR EQUIVALENT	01108	
C40	4.7pF ATC 100B CAPACITOR OR EQUIVALENT	01108	
C41 x 2	2 x 1÷5pF JOHANSON SMD TRIMMER	1485	
C42 x 2	2 x 1÷5pF JOHANSON SMD TRIMMER	1485	
C43	3.6pF ATC 100B CAPACITOR OR EQUIVALENT	01104B	
C44	3.6pF ATC 100B CAPACITOR OR EQUIVALENT	01104B	
C45	6.8pF ATC 100B CAPACITOR OR EQUIVALENT	01111	
C46	6.8pF ATC 100B CAPACITOR OR EQUIVALENT	01111	
C47	6.8pF ATC 100B CAPACITOR OR EQUIVALENT	01111	
C48	6.8pF ATC 100B CAPACITOR OR EQUIVALENT	01111	
C49	13pF ATC 100B CAPACITOR OR EQUIVALENT	01119A	
C50	13pF ATC 100B CAPACITOR OR EQUIVALENT	01119A	
C51	8.2pF ATC 100B CAPACITOR OR EQUIVALENT	01113	
C52	8.2pF ATC 100B CAPACITOR OR EQUIVALENT	01113	
C53	8.2pF ATC 100B CAPACITOR OR EQUIVALENT	01113	
C54	8.2pF ATC 100B CAPACITOR OR EQUIVALENT	01113	
C55	10pF ATC 100B CAPACITOR OR EQUIVALENT	01117	
C56	10pF ATC 100B CAPACITOR OR EQUIVALENT	01117	
C57	4.7pF ATC 100B CAPACITOR OR EQUIVALENT	01108	
C58	4.7pF ATC 100B CAPACITOR OR EQUIVALENT	01108	
C59	0.3pF ATC 100B CAPACITOR OR EQUIVALENT	01160	
T1	BLF861A RF LDMOS POWER TRANSISTOR	04034	
T2	BLF861A RF LDMOS POWER TRANSISTOR	04034	
B1	COAX 2:1 BALUN	08491	

---

REF.	DESCRIPTION	ELETTRONIKA CODE	Page 3/3
B2	COAX 2:1 BALUN	08491	
B3	COAX 4:1 BALUN	08492	
B4	COAX 4:1 BALUN	08492	
L1	4 TURNS SILV. COP. WIRE 1.2mm WOUND ON OD 5mm	07684	
L2	4 TURNS SILV. COP. WIRE 1.2mm WOUND ON OD 5mm	07684	
L3	½ TURN COIL		
L4	½ TURN COIL		
H1	HYBRID COUPLER 3dB 90° ANAREN	05368	
H2	HYBRID COUPLER 3dB 90° SAGE	05369	
NTC1	NTC 100KΩ PTH	00661	
NTC2	NTC 100KΩ PTH	00661	
IC1	DG419DY	04583	
IC2	DG419DY	04583	
DZ1	15V SMD ZENER DIODE	03135	
DZ2	15V SMD ZENER DIODE	03135	
DZ3	6.8V SMD ZENER DIODE	03137	
DZ4	6.8V SMD ZENER DIODE	03137	
DL1	SMD LED DIODE - RED -	03056	
DL2	SMD LED DIODE - RED -	03056	
PN964AR3	PCB	0643K	
	Torretta 3x10 f/f	V0774	
	Imballo velapack 200x125x50	09983	

DESCRIPTION

The control board SCH0223AR1 manages the operational logic of the amplifier: switching on and off, power supply and fans, alarms and protections, remote control, human-machine interface. There are managed by a modern and powerful 16 bit micro-controller (MB90F543), made by Fujitsu, which is the main part of the board.

Picture 1 shows the block diagram.

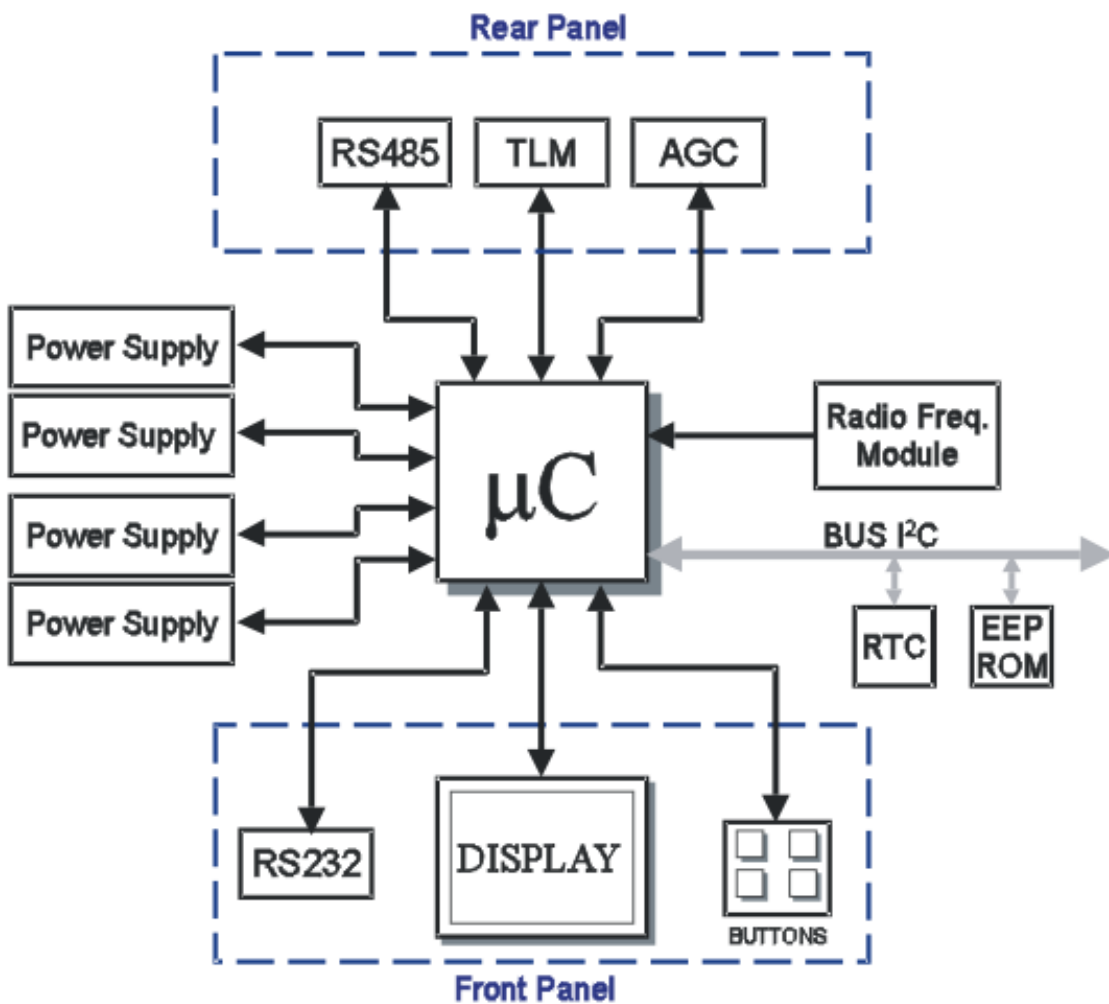

Picture 1: Simplified block diagram of the control and display board

---

It can be seen that the micro-controller is the heart of the control system, to which the various peripherals (power supply, serial ports, telemeasure socket, AGC port, RF amplifier module, ROM, clock, display and keys) are interfaced.

### **- Power Supply**

The board is powered with a continuous +24V voltage from which the +5V voltage powering the most of the chips (micro-controller, operational amplifiers, display, etc.) is derived by means of a switching converter (see IC19). A +12Vdc voltage is obtained from it as well, by means of a linear conversion provided by the integrated circuit IC8. From this, a -12Vdc voltage is obtained by means of the integrated circuit IC5. The -12V voltage is also used to adjust the contrast of the display.

### **- Connectors**

On the board SCH0223AR1 there are several connectors used as interfaces for the peripherals of the apparatus and the ports for external communication.

#### **POWER SUPPLY**

The connectors J1, J6, J8 e J12 are connected to the power supply powering the RF amplifier modules. The number of power supply used changes depending on the amplifier, up to four power supply. They are connected in the order shown in Table 1 below. Remaining connectors, if any, are left unused.

<b>CONNECTOR</b>	<b>POWER SUPPLY N°</b>
J1	1
J6	2
J8	3
J12	4

Table 1: Interface connectors for the power supply

Through this connection, each power supply provides the two levels of voltage and current acquired by the micro-controller by means of an internal ADC. Besides the connectors allow the control board to turn on or off the individual power supply (for instance when an alarm occurs). The used power supply are protected

---

against voltage surges or temperature increases. If one of these events occurs, the power supply is switched off and the event is signalled to the micro-controller through the connection with the control board.

#### RF AMPLIFICATION

The J3 connector interfaces the control board with the RF amplification section. Through this connector the micro-controller acquires the sample of forward and reflected power, unbalancing (if any), and temperature of the critic amplification area. It also allows to inhibit the transistors in case of reflected power alarm, by means of a totally hardware, thus extremely fast protection.

Depending on the apparatus, this connector may also allow to enable or disable the cooling fans of the critic area.

#### RS485

The J11 connector (10 pin socket) is directly wired to a DB9 female connector placed on the rear panel of the apparatus. This communication bus allows to connect the amplifier to the control (Amplifier Control) module of a high-power transmitter composed by several individual amplifiers. In this case, each amplifier and the Amplifier Control are connected to the same 4-wires RS485 bus and each of them as a unique address (which can be set by means of the keys and the display) for correct communication.

In case of single (stand-alone) amplifier, the RS485 connector can be used for connection to the Remote Control Unit (RCU) made by Elettronika S.r.l. This unit allows to monitor and control the remote transmitter from any site provided with PSTN or GSM<sup>1</sup> phone connection.

Table 2 shows the wiring between the J11 connector on the board and the DB9 female connector on the rear panel, along with the description of the lines.

PIN N° ON DB9	PIN N° ON J11	DESCRIPTION
1	1	Not used
2	3	Rx-
3	5	Rx+
4	7	+5V
5	9	GND
6	2	Not used
7	4	Tx-
8	6	Tx+
9	8	Not used

Table 2: Description of the RS485 connector

---

<sup>1</sup> For more details about the control system contact the distributor or the manufacturer.



## TELEMEASURES

The J9 telemeasure connector (10 pins socket) is directly wired on a DB9 female connector placed on the rear panel. There are input and output digital lines (TTL level) and analog output lines on this connector, which are used to monitor and control the amplifier by means of a general-purpose remote control system.

The correspondende between the pins of the J9 connector on the board and the DB9 female connector on the rear panel, as well as the meaning of the various lines, is shown in table 3 below (the directions refers to the position of the micro-controller on the board).

PIN N° ON DB9	PIN N° ON J9	TYPE	DIRECTION	DESCRIPTION
1	1	Analog	Output	Forward power (*)
2	3	Analog	Output	Reflected power (*)
3	5	Analog	Output	Temperature
4	7	Digital	Input	Interlock: 0V = Interlock Alarm 5V = Normal
5	9	-	-	Ground
6-7	2-4	Digital	Output	Free Contact (closed when amplifier is in alarm)
8	6	Digital	Input	Turning-on control (usually high, active when low)
9	8	Digital	Input	Turning-off control (usually high, active when low)

(\*) You can select by means of two jumpers on the board (JP1 and JP2) RMS or peak power. If there are two jumpers on pins 1 and 2 of JP1 and JP2 connector, RMS power is selected. Otherwise, if there are two jumpers on pins 2 and 3 of the same connectors, peak power is selected.

Table 3: Description of the telemeasures connector

The input stage of the digital controls has an internal pull-up towards the 5V power supply voltage. To use this lines it only takes setting a switch to close to earth, when closed, the relevant control (turning on or off) is enabled and the switch may be switched open again (impulse controls).

The interlock pin may be used as protection so that the amplifier is switched off the digital input level is low. It is possible to use several serially connected switches to make an interlock chain. Usually all switches are closed and the interlock level is low, thus the amplifier is on. If even only one of the switches is opened, the

level of the interlock signal becomes high (this line has a pull-up towards the +5V power supply voltage as well) and the protection for interlock alarm is activated for the amplifier, which is switched off. Note that in case the interlock protection is not used, the pin 4 of the DB9 telemeasures connector and the earth pin (pin 5) must be short circuited. Otherwise it is possible to disable the monitoring of the interlock chain from menu (see user manual).

Picture 2 shows a usage for the digital input signals to turn on and off the amplifier and for the interlock alarm.

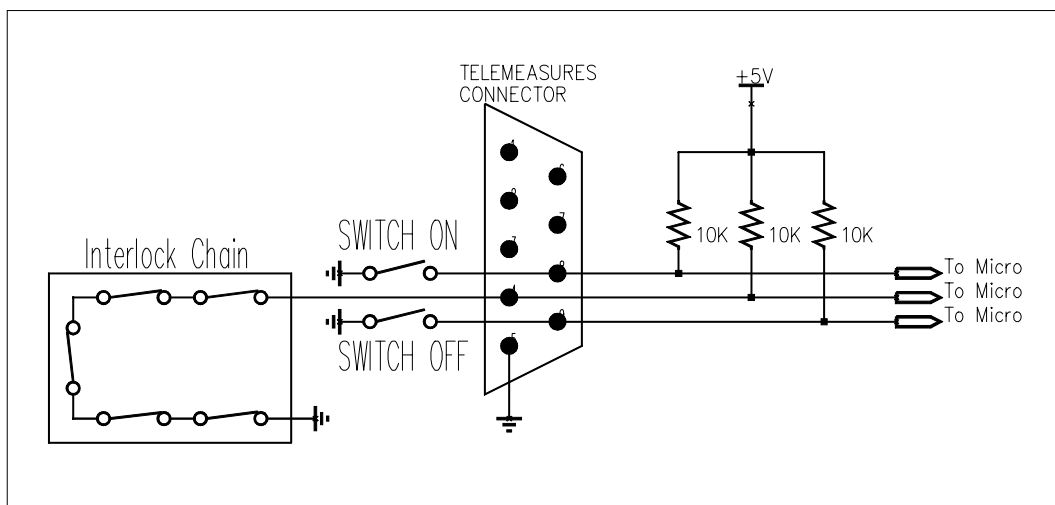

Picture 2: Usage of the digital input signals of the telemeasures connector

### AGC / EXCITER

The connector called J10, as the telemeasures connector and the RS485 bus, is wired to a DB9 female connector placed on the rear panel of the amplifier. This connectors allow the implementation of an automatic gain control between an exciter and the amplifier. A voltage signal related to the forward output power supplied by the amplifier is provided through two pins of the AGC connector. Connecting one of these to the relevant input pin of the exciter, this can pursuit a given voltage level, so that the output power is always constant. In order to avoid that, in case of an alarm decreasing the forward power, the exciter strongly increases the output level due to the AGC, thus damaging the amplification stages, the connector is provided with two digital output lines called AGC Alarm. Under alarm conditions, this lines are brought by the micro-controller at a low level, so that the exciter can stop the AGC.

Table 4 shows the connection between the J10 connector on the board and the DB9 connector on the rear panel, along with the description of each pin (the direction of the pin is referred to the position of the micro-controller on the board).

PIN N° ON DB9	PIN N° ON J10	TYPE	DIRECTION	DESCRIPTION
1	1	-	-	Ground
2	3	Digital	Output	AGC Alarm 0V = Alarm 5V = Normal
3	5	Digital	Output	AGC Alarm 0V = Alarm 5V = Normal
4	7	-	-	Not used
5	9	-	-	Not used
6	2	-	-	Not used
7	4	-	-	Not used
8	6	Analog	Output	Forward power
9	8	Analog	Output	Forward power

Table 4: Description of the AGC connector

## RS232

The DB9 female connector on the front panel is an external communication RS232 serial port, through which a PC can be connected directly to the amplifier in order to perform operations such as the remote control (by means of an adequate software<sup>2</sup>) and the update of the microcontroller firmware.

The used communication protocol is asynchronous, at a 19200bps speed, 1 start bit, 8 data bits, 1 stop bit, no parity. No hardware flow is used. The connector is DCE type and the pin used are shown in Table 5.

PIN N° ON DB9	1	2	3	4	5	6	7	8	9
DESCRIPTION	-	TxD	RxD	-	GND	-	-	-	-

Table 5: Description of the RS232 connector

## MISCELLANEOUS

The J2 (called AUX), J4, J5 and J17 connectors are not used and are there only for future updates. The SW1 dip-switches are partially used for the configuration of the correct mode for the micro-controller. The other switches are not used. It is important that the position of the dip-switches is left unchanged, because changing it may set a wrong mode for the micro-controller, affecting the work of the whole amplifier.

<sup>2</sup> For more information about this application contact the distributor of the manufacturer.

---

## FIRMWARE UPDATE

The micro-controller MB90F543 is provided with a built-in Flash memory containing the firmware. The firmware can be updated to later versions without removing the apparatus from the rack and/or replacing the chip.

To upgrade it, connect a PC to the RS232 socket on the front panel of the apparatus by means of a cable DB9 male - DB9 female (pin-to-pin).

Launch on the PC the EKAFlash application, select the serial port in use of the PC and choose the update file by pressing the “...” key and click on Download button.

Eventually, turn off the amplifier from the main switch and then turn it on again. The upgrade of the firmware begins on the EKAFlash window. Picture 3 shows this window while a firmware is being updated.

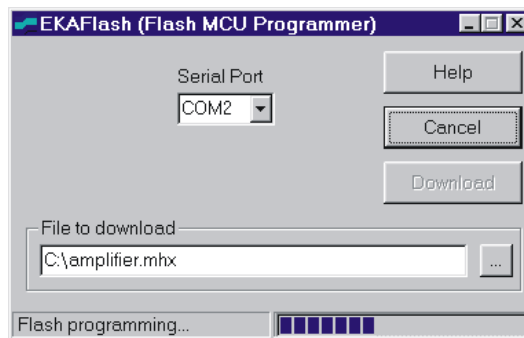

Picture 3: The EKAFlash window while updating a firmware

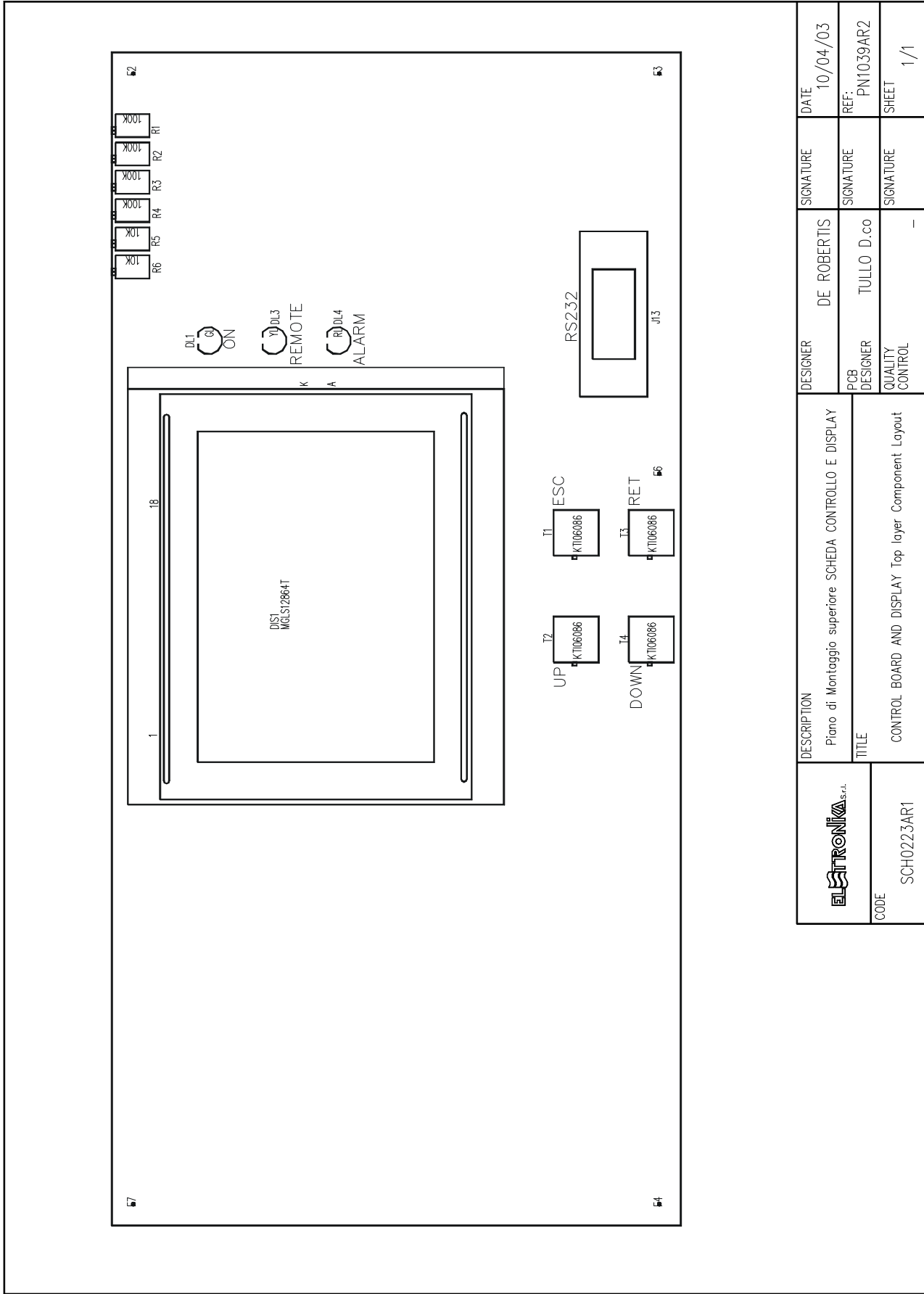

 CODE SCH0223AR1	DESCRIPTION Piano di Montaggio superiore SCHEDA CONTROLLO E DISPLAY		DESIGNER	DE ROBERTIS	SIGNATURE	DATE	10/04/03
	TITLE CONTROL BOARD AND DISPLAY Top layer Component Layout		PCB DESIGNER	TULLO D.co	SIGNATURE	REF:	PN1039AR2
			QUALITY CONTROL	-	SIGNATURE	SHEET	1/1

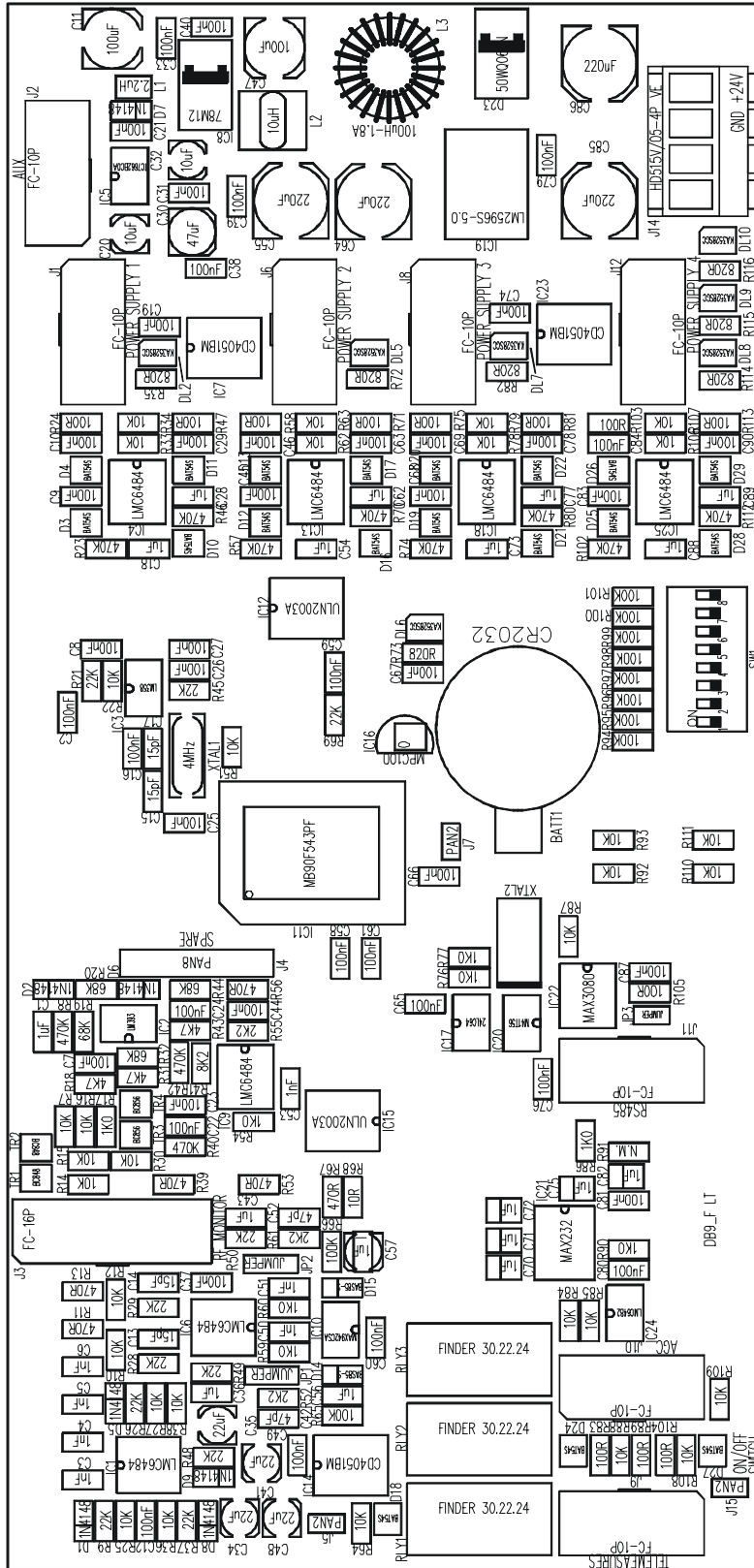

	DESCRIPTION	DESIGNER	SIGNATURE	DATE
	Piano di Montaggio inferiore SCHEDA CONTROLLO E DISPLAY TITLE CONTROL BOARD AND DISPLAY Bot layer Component Layout	DE ROBERTIIS PCB DESIGNER TULLO D.co QUALITY CONTROL	DE ROBERTIIS TULLO D.co _____	10/04/03 REF: PN1039AR2 SHEET 1/1
CODE	SCH023AR1			

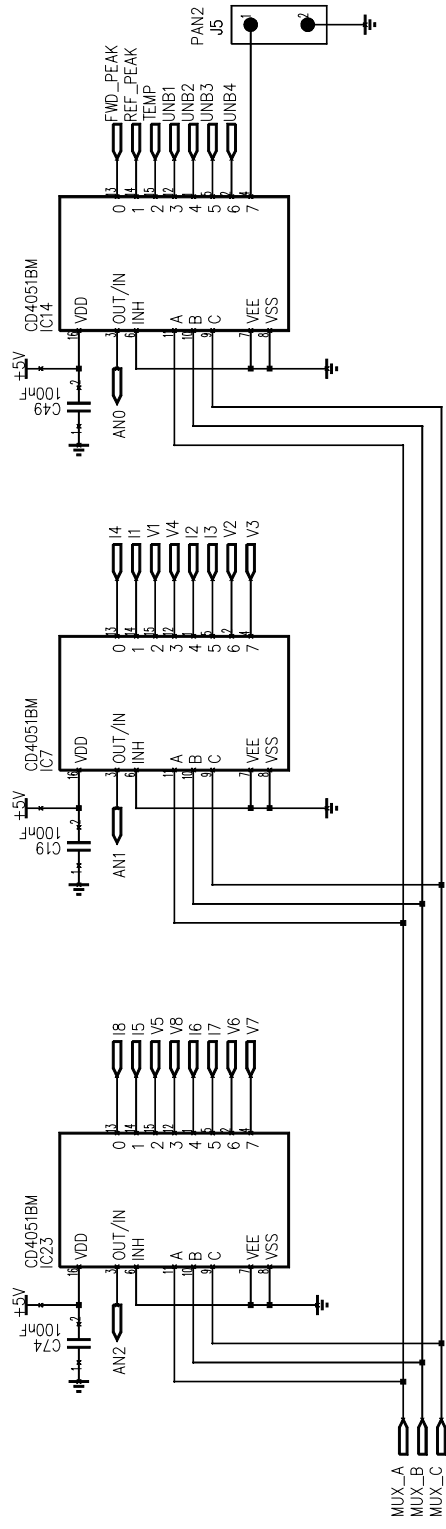

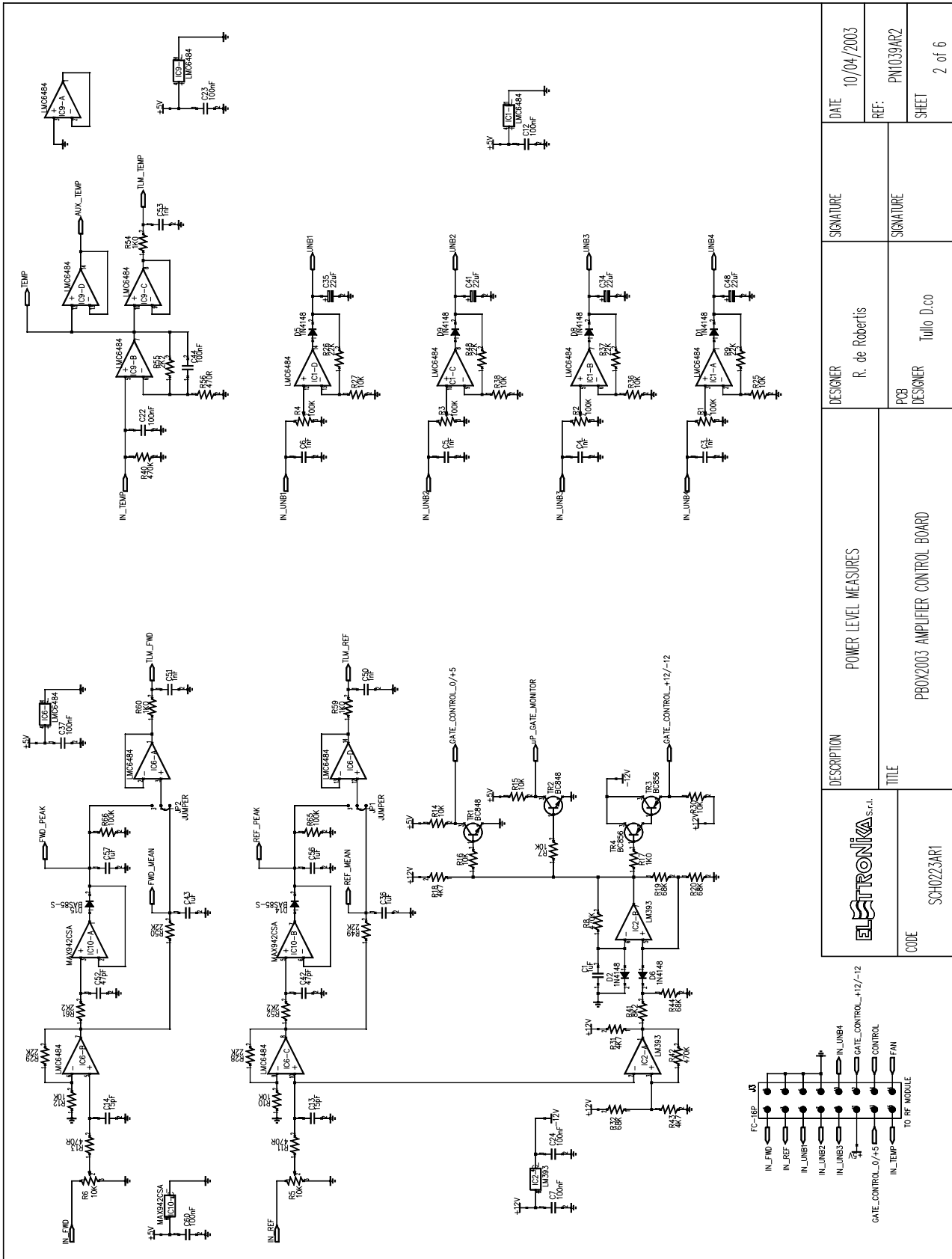

	DESCRIPTION	MULTIPLEXER	DESIGNER	R. de Robertis	SIGNATURE	DATE	10/04/2003
	TITLE	PBOX2003 AMPLIFIER CONTROL BOARD	PCB DESIGNER	Tullio D.co	SIGNATURE	REF:	PN1039AR2
CODE	SCH0223AR1			SHEET	1 of 6		



<b>ELSTRONIKA</b> S.r.l.	DESCRIPTION	POWER LEVEL MEASURES	
	TITLE	PBOX203 AMPLIFIER CONTROL BOARD	
CODE	SC4023A1	DESIGNER	R. de Robertis
		SIGNATURE	
		PCB DESIGNER	Tullio D.co
		SIGNATURE	
		DATE	10/04/2003
		REF:	PN1039AR2
		SHEET	2 of 6

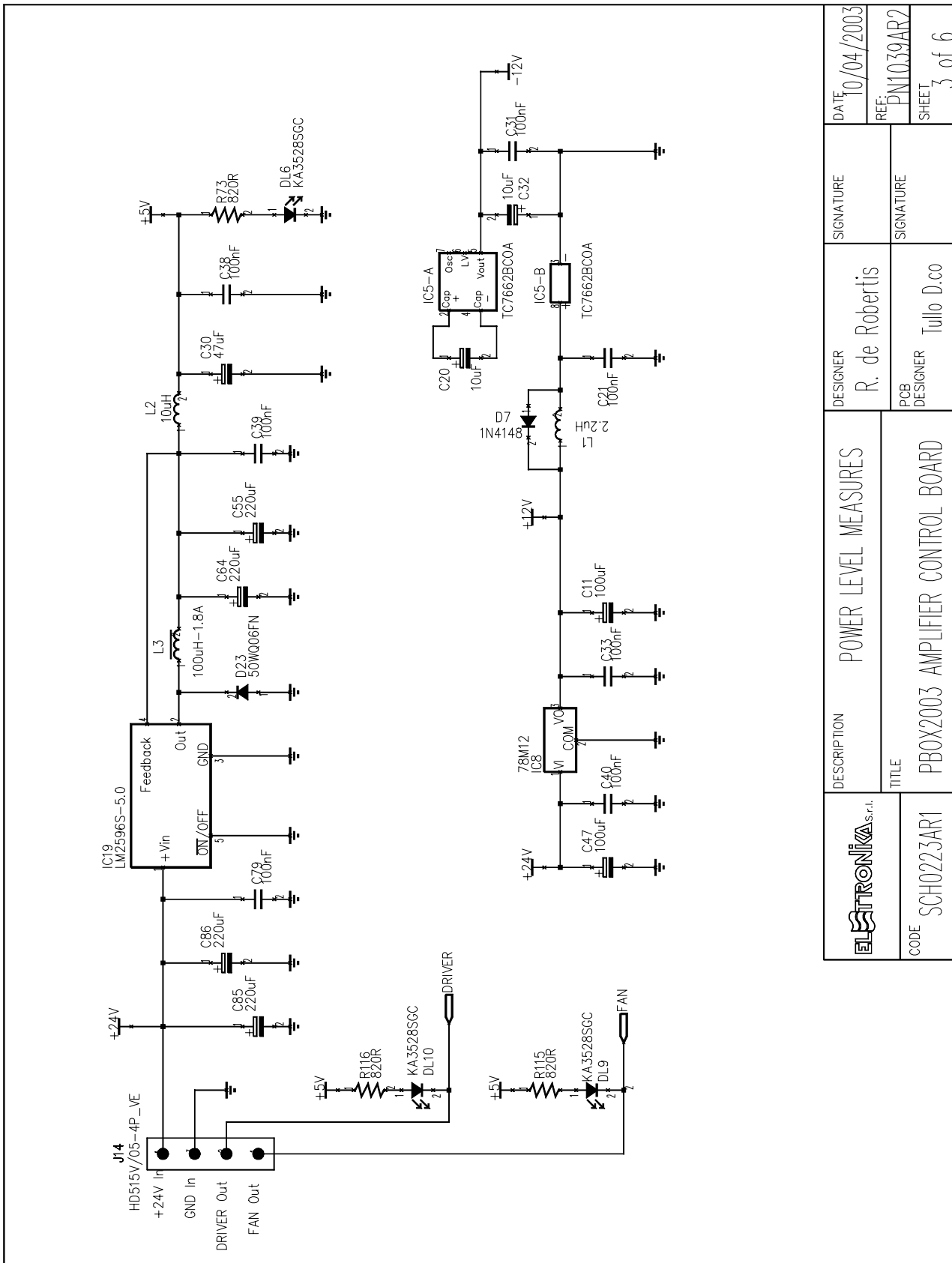



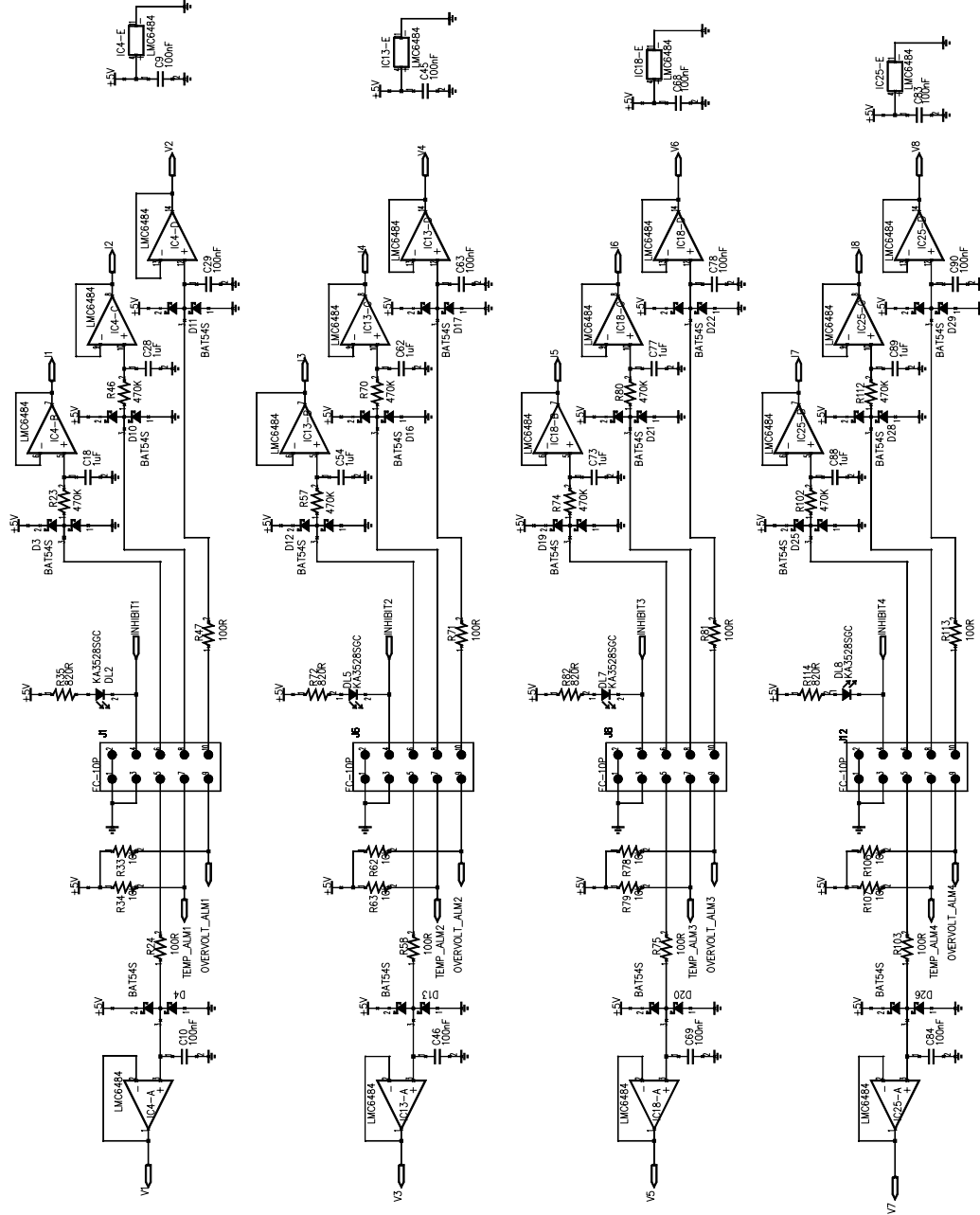

	DESCRIPTION	POWER LEVEL MEASURES		DESIGNER	R. de Robertis	SIGNATURE		DATE	10/04/2003
	TITLE	PBOX2003 AMPLIFIER CONTROL BOARD		PCB DESIGNER	Tullio D. co	SIGNATURE		REF.	PN1039AR2
CODE	SCH0223AR1							SHEET	3 of 6

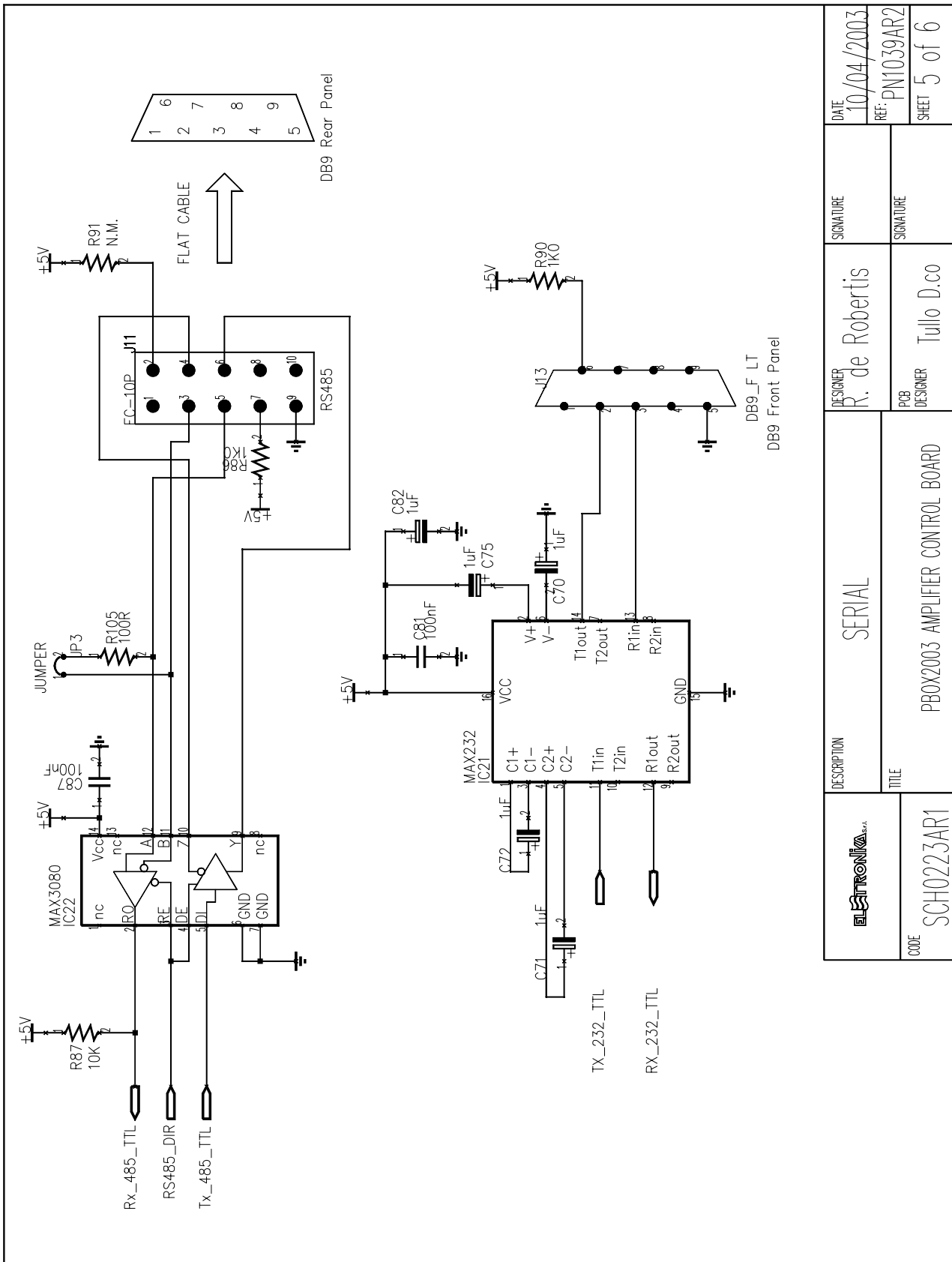

DESCRIPTION	POWER SUPPLY MEASURES		DESIGNER	R. de Robertis	SIGNATURE	DATE	10/04/2003
	TITLE	PBOX2003 AMPLIFIER CONTROL BOARD		PCB DESIGNER		Tullio D.co	REF:
CODE	SCH0223AR1				SHEET	4 of 6	



	DESCRIPTION	SERIAL	
	TITLE	PBOX2003 AMPLIFIER CONTROL BOARD	
CODE	SCH0223AR1	DESIGNER	R. de Robertis
		PCB DESIGNER	Tullo D.co
		SIGNATURE	
		SIGNATURE	
		DATE	10/04/2003
		REF:	PN1039AR2
		SHEET	5 of 6

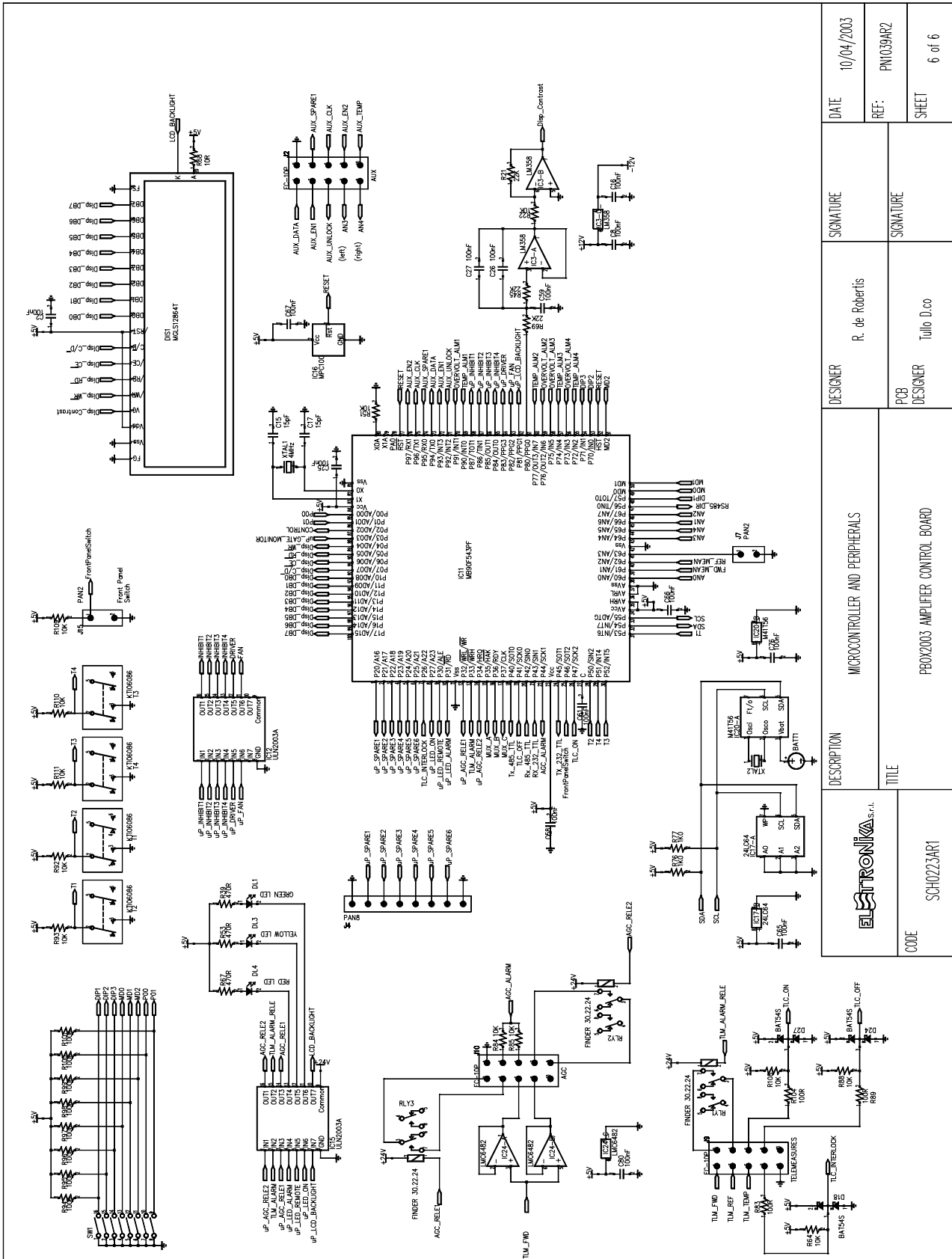

<b>DESCRIPTION</b> MICROCONTROLLER AND PERIPHERALS CODE SCH0223AR1	<b>DESIGNER</b> R. de Robertis	<b>SIGNATURE</b> Tullio D'co	<b>DATE</b> 10/04/2003
	<b>PCB DESIGNER</b> Tullio D'co	<b>SIGNATURE</b>	<b>REF:</b> PNOG39AR2
<b>TITLE</b> PROX2003 AMPLIFIER CONTROL BOARD	<b>SIGNATURE</b>	<b>SHEET</b> 6 of 6	

## COMPONENT LIST SCH0223AR1

Part Name/Number	Description	Qty.	Comps.	Page 1/2
BATT BH001RB 3093_90	03093 03090 BATTERY HOLDER	1	BATT1	
CC 100nF-S 01065C	01065C Y5V 1206 COND	46	C2, C7-10, C12, C16, C19, C21-27 C29, C31, C33, C37-40, C44-46, C49, C58-61, C63, C65-69, C74, C76, C78-81, C83-84, C87, C90	
CC 15pF-S 01088	01088 SMD 1206 COND	4	C13-15, C17	
CC 1nF-S 01096	01096 SMD 1206 COND	7	C3-6, C50-51, C53	
CC 1uF100V-S 01760A	01760A Y5V 1206 COND	13	C1, C18, C28, C36, C43, C54, C56-57, C62, C73, C77, C88-89	
CC 47pF-S 01100	01100 SMD 1206 COND	2	C42, C52	
CE 100uF25V-S 01793B	01793B ELETTR SMD COND	2	C11, C47	
CE 10uF35V-S 01778A	01778A ELETTR SMD COND	2	C20, C32	
CE 1uF35V-S 01613A	01613A TANTALIUM ELETTR SMD CO	5	C70-72, C75, C82	
CE 220uF50V LOW ESR	1799A ELETTR SMD COND LOW ESR	4	C55, C64, C85-86	
CE 22uF16V-S	01780A ELETTR SMD COND	4	C34-35, C41, C48	
CE 47uF35V-S 01790A	01790A ELETTR SMD COND	1	C30	
D 1N4148-S 03002	03002 SMD DIODE	7	D1-2, D5-9	
D 50WQ06FN	03019A SMD DIODE SCHOTTKY 5,5A	1	D23	
D BAS85-S	03024 SMD DIODE SCHOTTKY	2	D14-15	
D BAT54S	03199 SMD SCHOTTKY DIODE A-K T	19	D3-4, D10-13, D16-22, D24-29	
DIS MGLS12864T	03083A 128x64 DOT (BLUE-LED WH	1	DIS1	
DL KA-3528SGC 03057	03057 GREEN SMD LED DIODE	7	DL2, DL5-10	
DL LEDG5 03060	03060 GREEN LED DIODE 5mm	1	DL1	
DL LEDR5 03061	03061 RED LED DIODE 5mm	1	DL4	
DL LEDY5 03054B	03054B YELLOW LED DIODE 5mm	1	DL3	
IC 24LC64 04815	04815 SMD INTEG CIRCUIT	1	IC17	
IC 78M12 4307B	04307B SMD VOLTAGE REGULATOR	1	IC8	
IC CD4051BM-S	04615 SMD INTEG CIRCUIT	3	IC7, IC14, IC23	
IC LM2596S-5.0	04580 SMD INTEG CIRCUIT	1	IC19	
IC LM358M-S 04660	04660 SMD INTEG CIRCUIT	1	IC3	
IC LM393-S 04639	04639 SMD INTEG CIRCUIT	1	IC2	
IC LMC6482-S	04632 SMD INTEG CIRCUIT	1	IC24	
IC LMC6484-S	04634 SMD INTEG CIRCUIT	7	IC1, IC4, IC6, IC9, IC13, IC18, IC25	
IC M41T56 04611	04611 SMD INTEG CIRCUIT	1	IC20	
IC MAX232-S 04804B	04804B SMD INTEG CIRCUIT	1	IC21	
IC MAX3080-S 04770	04770 SMD INTEG CIRCUIT	1	IC22	
IC MAX942CSA-S	04572 SMD INTEG CIRCUIT	1	IC10	
IC MB90F543PF	04596 SMD INTEG CIRCUIT	1	IC11	
IC MPC100-450DI-TO	04608 INTEG CIRCUIT	1	IC16	
IC TC7662BCOA 04758A	04758A SMD INTEG CIRCUIT	1	IC5	
IC ULN2003A 4870	04870 SMD INTEG CIRCUIT	2	IC12, IC15	
IND 2u2H-S 05020A	05020A INDUCTOR	1	L1	

Part Name/Number	Description	Qty.	Comps.	Page 2/2
IND MS85 10uH-S	04948 INDUCTOR 2,7 A	1	L2	
IND T100uH-1.8A 4958	04958 TOROIDAL-STORAGE CHOKES	1	L3	
J CON HD515V/05-4PVE	02881 + 02882 PANDUIT PCB CONN	1	J14	
J DB9_F-0° LT	02794 PCB CONNECTOR DB9 LONG T	1	J13	
JFC-10P 02697-02699	02697+02699 PCB CONNECTOR POL	8	J1-2, J6, J8-12	
JFC-16P 02701-02700	02701+02700 PCB CONNECTOR POL	1	J3	
J PAN2 02739-40-41	02739+02740+02741 PCB CONNECTO	3	J5, J7, J15	
J PAN8 02716	02716 PCB CONNECTOR	1	J4	
JU JUMP2 02739-02742	02739+02742 MASCHIO PAN2	1	JP3	
JU JUMP3 02707-02742	02707+02742 MASCHIO PAN3	2	JP1-2	
R 100K-1%-S 00065B	00065B RES 1/4W 1% SMD 1206	10	R65-66, R94-101	
R 100R-1%-S 00029D	00029D RES 1/4W 1% SMD 1206	12	R24, R47, R58, R71, R75, R81, R83, R89, R103-105, R113	
R 10K-1%-S 00053B	00053B RES 1/4W 1% SMD 1206	32	R7, R10, R12, R14-16, R22, R25, R27, R30, R33-34, R36, R38, R51, R62-64, R78-79, R84-85, R87-88, R92-93, R106-111	
R 10R-S 00017A	00017A RES 1/4W 5% SMD 1206	1	R68	
R 1206 NOT MOUNTED	NOT MOUNTED RES 1/4W 5% SMD 12	1	R91	
R 1K0-1%-S 00041B	00041B RES 1/4W 1% SMD 1206	8	R17, R54, R59-60, R76-77, R86, R90	
R 22K-1%-S 00057B	00057B RES 1/4W 1% SMD 1206	11	R9, R21, R26, R28-29, R37, R45, R48-50, R69	
R 2K2-1%-S 00045B	00045B RES 1/4W 1% SMD 1206	3	R52, R55, R61	
R 470K-S 00073A	00073A RES 1/4W 5% SMD 1206	11	R8, R23, R40, R42, R46, R57, R70, R74, R80, R102, R112	
R 470R-1%-S 00037B	00037B RES 1/4W 1% SMD 1206	6	R11, R13, R39, R53, R56, R67	
R 4K7-1%-S 00049B	00049B RES 1/4W 1% SMD 1206	3	R18, R31, R43	
R 68K-1%-S 00063B	00063B RES 1/4W 1% SMD 1206	4	R19-20, R32, R44	
R 820R-S 00040A	00040A RES 1/4W 5% SMD 1206	7	R35, R72-73, R82, R114-116	
R 8K2-1%-S 00052B	00052B RES 1/4W 1% SMD 1206	1	R41	
RL 30.22.24 07569	07569 RELE	3	RLY1-3	
RV 100K-3266X	00814 VARIABLE RESISTOR	4	R1-4	
RV 10K-3266X 00807	00807 VARIABLE RESISTOR	2	R5-6	
SW SWITCH-8DIP	07530A PCB DIP SWITCH SMD	1	SW1	
T 06086 N 7630 7632	7630 7632 KTI06086 PULSANTE 2	4	T1-4	
TR BC848 03457	03457 NPN SMD TRANSISTOR	2	TR1-2	
TR BC856 03455	03455 PNP SMD TRANSISTOR	2	TR3-4	
XTAL 32.768k-S 05146	05146 QUARTZ	1	XTAL2	
XTAL 4MHz-S 05101A	05101A QUARTZ	1	XTAL1	